

A  
EC  
C  
D  
E  
F  
G  
H  
I  
J  
K  
L  
M  
N  
O  
P

# SECTION EC

## ENGINE CONTROL SYSTEM

### CONTENTS

|  |           |
|--|-----------|
| <b>VQ37VHR FOR USA AND CANADA</b>  |           |
| <b>PRECAUTION</b> .....  | <b>31</b> |
| <b>PRECAUTIONS</b> .....   | <b>31</b> |
| Precaution for Supplemental Restraint System (SRS) "AIR BAG" and "SEAT BELT PRE-TENSIONER" ..... | 31        |
| Precaution for Procedure without Cowl Top Cover... ..  | 31        |
| Precautions For Xenon Headlamp Service .....   | 31        |
| On Board Diagnostic (OBD) System of Engine and A/T .....   | 32        |
| General Precautions .....  | 32        |
| <b>PREPARATION</b> .....   | <b>36</b> |
| <b>PREPARATION</b> .....   | <b>36</b> |
| Special Service Tools .....  | 36        |
| Commercial Service Tools .....   | 36        |
| <b>SYSTEM DESCRIPTION</b> .....  | <b>38</b> |
| <b>COMPONENT PARTS</b> .....   | <b>38</b> |
| <b>ENGINE CONTROL SYSTEM</b> .....   | <b>38</b> |
| ENGINE CONTROL SYSTEM : Component Parts Location .....   | 38        |
| ENGINE CONTROL SYSTEM : Component Description .....  | 41        |
| <b>INFINITI DRIVE MODE SELECTOR</b> .....  | <b>42</b> |
| Infiniti Drive Mode Selector : Component Parts Location .....                                    | 43        |
| Infiniti Drive Mode Selector : Component Description .....                                       | 43        |
| Accelerator Pedal Position Sensor .....  | 44        |
| Air Fuel Ratio Sensor 1 .....  | 44        |
| Air Fuel Ratio Sensor 1 Heater .....   | 44        |
| ASCD Brake Switch .....  | 45        |
| ASCD Indicator .....   | 45        |
| ASCD Steering Switch .....   | 45        |
| Battery Current Sensor (With Battery Temperature Sensor) .....                                   | 45        |
| Brake Switch .....   | 46        |
| Camshaft Position Sensor (PHASE) .....   | 46        |
| Cooling Fan .....  | 46        |
| Crankshaft Position Sensor (POS) .....   | 47        |
| ECM .....  | 47        |
| Electric Throttle Control Actuator .....   | 47        |
| Engine Coolant Temperature Sensor .....  | 47        |
| Engine Oil Temperature Sensor .....  | 48        |
| EVAP Canister Purge Volume Control Solenoid Valve .....  | 48        |
| EVAP Canister Vent Control Valve .....   | 49        |
| EVAP Control System Pressure Sensor .....  | 49        |
| Fuel Injector .....  | 49        |
| Fuel Level Sensor .....  | 49        |
| Fuel Pump .....  | 49        |
| Fuel Tank Temperature Sensor .....   | 50        |
| Heated Oxygen Sensor 2 .....   | 50        |
| Heated Oxygen Sensor 2 Heater .....  | 50        |
| Ignition Coil .....  | 51        |
| Intake Air Temperature Sensor .....  | 51        |
| Intake Valve Timing Control Solenoid Valve .....   | 51        |
| ICC Brake Switch .....   | 51        |
| ICC Steering Switch .....  | 52        |
| Knock Sensor .....   | 52        |
| Manifold Absolute Pressure Sensor .....  | 52        |
| Malfunction Indicator Lamp .....   | 52        |
| Mass Air Flow Sensor .....   | 52        |
| Power Steering Pressure Sensor .....   | 52        |
| Refrigerant Pressure Sensor .....  | 53        |
| Throttle Control Motor .....   | 53        |
| Throttle Control Motor Relay .....   | 53        |
| Throttle Position Sensor .....   | 53        |
| VVEL Actuator Motor .....  | 53        |
| VVEL Actuator Motor Relay .....  | 53        |
| VVEL Control Module .....  | 54        |
| VVEL Control Position Sensor .....   | 54        |
| <b>STRUCTURE AND OPERATION</b> .....   | <b>55</b> |
| Positive Crankcase Ventilation .....   | 55        |

|   |           |   |            |
|---|-----------|---|------------|
| On Board Refueling Vapor Recovery (ORVR) .....                                  | 56        | INTAKE VALVE TIMING CONTROL : System Description .....                              | 68         |
| <b>SYSTEM .....</b>   | <b>57</b> | <b>VVEL SYSTEM .....</b>  | <b>69</b>  |
| <b>ENGINE CONTROL SYSTEM .....</b>  | <b>57</b> | VVEL SYSTEM : System Diagram .....  | 69         |
| ENGINE CONTROL SYSTEM : System Diagram..  | 57        | VVEL SYSTEM : System Description .....  | 69         |
| ENGINE CONTROL SYSTEM : System Description .....                                | 58        | <b>INFINITI DRIVE MODE SELECTOR .....</b>   | <b>70</b>  |
| <b>MULTIPOINT FUEL INJECTION SYSTEM .....</b>                                   | <b>58</b> | Infiniti Drive Mode Selector : System Description ...                               | 71         |
| MULTIPOINT FUEL INJECTION SYSTEM :  |           | <b>OPERATION .....</b>  | <b>74</b>  |
| System Diagram .....  | 58        | <b>AUTMATIC SPEED CONTROL DEVICE (ASCD) ...</b>                                     | <b>74</b>  |
| MULTIPOINT FUEL INJECTION SYSTEM : System Description .....                     | 58        | AUTMATIC SPEED CONTROL DEVICE (ASCD) : Switch Name and Function .....               | 74         |
| <b>ELECTRIC IGNITION SYSTEM .....</b>   | <b>61</b> | <b>HANDLING PRECAUTION .....</b>  | <b>76</b>  |
| ELECTRIC IGNITION SYSTEM :  |           | Infiniti Drive Mode Selector .....  | 76         |
| System Diagram .....  | 61        | <b>ON BOARD DIAGNOSTIC (OBD) SYSTEM ....</b>  | <b>77</b>  |
| ELECTRIC IGNITION SYSTEM : System Description .....                             | 61        | Diagnosis Description .....   | 77         |
| <b>AIR CONDITIONING CUT CONTROL .....</b>                                       | <b>62</b> | GST (Generic Scan Tool) .....   | 77         |
| AIR CONDITIONING CUT CONTROL : System Diagram .....                             | 62        | <b>DIAGNOSIS SYSTEM (ECM) .....</b>   | <b>78</b>  |
| AIR CONDITIONING CUT CONTROL : System Description .....                         | 62        | <b>DIAGNOSIS DESCRIPTION .....</b>  | <b>78</b>  |
| <b>AUTOMATIC SPEED CONTROL DEVICE (ASCD)..</b>                                  | <b>62</b> | DIAGNOSIS DESCRIPTION : 1st Trip Detection Logic and Two Trip Detection Logic ..... | 78         |
| AUTOMATIC SPEED CONTROL DEVICE (ASCD) : System Diagram .....                    | 63        | DIAGNOSIS DESCRIPTION : DTC and Freeze Frame Data .....                             | 78         |
| AUTOMATIC SPEED CONTROL DEVICE (ASCD) : System Description .....                | 63        | DIAGNOSIS DESCRIPTION : Counter System .....  | 79         |
| <b>CAN COMMUNICATION .....</b>  | <b>64</b> | DIAGNOSIS DESCRIPTION : Driving Pattern .....                                       | 82         |
| CAN COMMUNICATION : System Description .....                                    | 64        | DIAGNOSIS DESCRIPTION : System Readiness Test (SRT) Code .....                      | 83         |
| <b>COOLING FAN CONTROL .....</b>  | <b>64</b> | DIAGNOSIS DESCRIPTION : Permanent Diagnostic Trouble Code (Permanent DTC) .....     | 84         |
| COOLING FAN CONTROL : System Diagram .....                                      | 64        | DIAGNOSIS DESCRIPTION : Malfunction Indicator Lamp (MIL) .....                      | 85         |
| COOLING FAN CONTROL : System Description..                                      | 64        | On Board Diagnosis Function .....   | 85         |
| <b>EVAPORATIVE EMISSION SYSTEM .....</b>  | <b>65</b> | CONSULT Function .....  | 88         |
| EVAPORATIVE EMISSION SYSTEM : System Diagram .....                              | 65        | <b>ECU DIAGNOSIS INFORMATION .....</b>  | <b>98</b>  |
| EVAPORATIVE EMISSION SYSTEM : System Description .....                          | 65        | <b>ECM .....</b>  | <b>98</b>  |
| <b>ENGINE PROTECTION CONTROL AT LOW ENGINE OIL PRESSURE .....</b>               | <b>66</b> | Reference Value .....   | 98         |
| ENGINE PROTECTION CONTROL AT LOW ENGINE OIL PRESSURE : System Diagram .....     | 66        | Fail safe .....   | 114        |
| ENGINE PROTECTION CONTROL AT LOW ENGINE OIL PRESSURE : System Description ..... | 67        | DTC Inspection Priority Chart .....   | 116        |
| <b>FUEL FILLER CAP WARNING SYSTEM .....</b>                                     | <b>67</b> | DTC Index .....   | 117        |
| FUEL FILLER CAP WARNING SYSTEM :  |           | Test Value and Test Limit .....   | 122        |
| System Diagram .....  | 67        | <b>VVEL CONTROL MODULE .....</b>  | <b>129</b> |
| FUEL FILLER CAP WARNING SYSTEM : System Description .....                       | 68        | Reference Value .....   | 129        |
| <b>INTAKE VALVE TIMING CONTROL .....</b>  | <b>68</b> | <b>WIRING DIAGRAM .....</b>   | <b>133</b> |
| INTAKE VALVE TIMING CONTROL : System Diagram .....                              | 68        | <b>ENGINE CONTROL SYSTEM .....</b>  | <b>133</b> |
|   |           | Wiring Diagram .....  | 133        |
|   |           | <b>BASIC INSPECTION .....</b>   | <b>139</b> |
|   |           | <b>DIAGNOSIS AND REPAIR WORKFLOW .....</b>  | <b>139</b> |
|   |           | Work Flow .....   | 139        |
|   |           | Diagnostic Work Sheet .....   | 142        |

|  |            |  |            |    |
|--|------------|--|------------|----|
| <b>ADDITIONAL SERVICE WHEN REPLACING ECM</b> .....                 | <b>144</b> | <b>POWER SUPPLY AND GROUND CIRCUIT</b> ..                          | <b>180</b> | A  |
| Description .....  | 144        | Diagnosis Procedure .....  | 180        |    |
| Work Procedure .....   | 144        | <b>POWER SUPPLY AND GROUND CIRCUIT (VVEL CONTROL MODULE)</b> ..... | <b>183</b> | EC |
| <b>ADDITIONAL SERVICE WHEN REPLACING VVEL CONTROL MODULE</b> ..... | <b>145</b> | Diagnosis Procedure .....  | 183        |    |
| Description .....  | 145        | <b>U0101 CAN COMM CIRCUIT</b> .....                                | <b>185</b> | C  |
| Work Procedure .....   | 145        | Description .....  | 185        |    |
| <b>VIN REGISTRATION</b> .....                                      | <b>146</b> | DTC Logic .....  | 185        |    |
| Description .....  | 146        | Diagnosis Procedure .....  | 185        |    |
| Work Procedure .....   | 146        | <b>U1001 CAN COMM CIRCUIT</b> .....                                | <b>186</b> | D  |
| <b>ACCELERATOR PEDAL RELEASED POSITION LEARNING</b> .....          | <b>147</b> | Description .....  | 186        |    |
| Description .....  | 147        | DTC Logic .....  | 186        |    |
| Work Procedure .....   | 147        | Diagnosis Procedure .....  | 186        | E  |
| <b>THROTTLE VALVE CLOSED POSITION LEARNING</b> .....               | <b>148</b> | <b>U1003 CAN COMM CIRCUIT</b> .....                                | <b>187</b> | F  |
| Description .....  | 148        | Description .....  | 187        |    |
| Work Procedure .....   | 148        | DTC Logic .....  | 187        |    |
| <b>IDLE AIR VOLUME LEARNING</b> .....                              | <b>149</b> | Diagnosis Procedure .....  | 187        |    |
| Description .....  | 149        | <b>U1024 CAN COMM CIRCUIT</b> .....                                | <b>189</b> | G  |
| Work Procedure .....   | 149        | Description .....  | 189        |    |
| <b>VVEL CONTROL SHAFT POSITION SENSOR ADJUSTMENT</b> .....         | <b>151</b> | DTC Logic .....  | 189        |    |
| Description .....  | 151        | Diagnosis Procedure .....  | 189        | H  |
| Work Procedure .....   | 151        | <b>P0011, P0021 IVT CONTROL</b> .....                              | <b>191</b> | I  |
| <b>MIXTURE RATIO SELF-LEARNING VALUE CLEAR</b> .....               | <b>153</b> | DTC Logic .....  | 191        |    |
| Description .....  | 153        | Diagnosis Procedure .....  | 192        |    |
| Work Procedure .....   | 153        | Component Inspection .....   | 193        |    |
| <b>BASIC INSPECTION</b> .....                                      | <b>154</b> | <b>P0031, P0032, P0051, P0052 A/F SENSOR 1 HEATER</b> .....        | <b>195</b> | J  |
| Work Procedure .....   | 154        | DTC Logic .....  | 195        |    |
| <b>FUEL PRESSURE CHECK</b> .....                                   | <b>158</b> | Diagnosis Procedure .....  | 195        |    |
| Work Procedure .....   | 158        | Component Inspection .....   | 197        | K  |
| <b>HOW TO SET SRT CODE</b> .....                                   | <b>160</b> | <b>P0037, P0038, P0057, P0058 HO2S2 HEATER</b> .....               | <b>198</b> | L  |
| Description .....  | 160        | DTC Logic .....  | 198        |    |
| SRT Set Driving Pattern .....                                      | 161        | Diagnosis Procedure .....  | 198        |    |
| Work Procedure .....   | 163        | Component Inspection .....   | 200        | M  |
| <b>HOW TO ERASE PERMANENT DTC</b> .....                            | <b>166</b> | <b>P006A, P0101, P010B MAF SENSOR</b> .....                        | <b>201</b> | N  |
| Description .....  | 166        | DTC Logic .....  | 201        |    |
| Work Procedure (Group A) .....                                     | 167        | Diagnosis Procedure .....  | 202        |    |
| Work Procedure (Group B) .....                                     | 169        | Component Inspection .....   | 204        |    |
| <b>DTC/CIRCUIT DIAGNOSIS</b> .....                                 | <b>172</b> | <b>P0075, P0081 IVT CONTROL SOLENOID VALVE</b> .....               | <b>208</b> | O  |
| <b>TROUBLE DIAGNOSIS - SPECIFICATION VALUE</b> .....               | <b>172</b> | DTC Logic .....  | 208        |    |
| Description .....  | 172        | Diagnosis Procedure .....  | 208        |    |
| Component Function Check .....                                     | 172        | Component Inspection .....   | 209        | P  |
| Diagnosis Procedure .....  | 173        | <b>P0102, P0103, P010C, P010D MAF SENSOR</b> .....                 | <b>211</b> |    |
|  |            | DTC Logic .....  | 211        |    |
|  |            | Diagnosis Procedure .....  | 211        |    |
|  |            | Component Inspection .....   | 213        |    |

|  |            |                           |     |  |            |
|--|------------|---------------------------|-----|--|------------|
| <b>P0106 MANIFOLD ABSOLUTE PRESSURE SENSOR</b> ..... | <b>217</b> | DTC Logic .....           | 217 | DTC Logic .....  | 247        |
| DTC Logic .....                                      | 217        | Diagnosis Procedure ..... | 218 | Diagnosis Procedure .....                                | 248        |
| Diagnosis Procedure .....                            | 218        |                           |     | <b>P0132, P0152 A/F SENSOR 1</b> .....                   | <b>250</b> |
| Component Inspection .....                           | 219        |                           |     | DTC Logic .....  | 250        |
|  |            |                           |     | Diagnosis Procedure .....                                | 251        |
| <b>P010A MANIFOLD ABSOLUTE PRESSURE SENSOR</b> ..... | <b>221</b> |                           |     | <b>P0133, P0153 A/F SENSOR 1</b> .....                   | <b>253</b> |
| DTC Logic .....                                      | 221        |                           |     | DTC Logic .....  | 253        |
| Diagnosis Procedure .....                            | 221        |                           |     | Diagnosis Procedure .....                                | 254        |
| Component Inspection .....                           | 222        |                           |     | <b>P0137, P0157 HO2S2</b> .....                          | <b>258</b> |
| <b>P0111 IAT SENSOR</b> .....                        | <b>224</b> |                           |     | DTC Logic .....  | 258        |
| DTC Logic .....                                      | 224        |                           |     | Component Function Check .....                           | 259        |
| Component Function Check .....                       | 225        |                           |     | Diagnosis Procedure .....                                | 260        |
| Diagnosis Procedure .....                            | 225        |                           |     | Component Inspection .....                               | 261        |
| Component Inspection .....                           | 225        |                           |     | <b>P0138, P0158 HO2S2</b> .....                          | <b>264</b> |
| <b>P0112, P0113 IAT SENSOR</b> .....                 | <b>226</b> |                           |     | DTC Logic .....  | 264        |
| DTC Logic .....                                      | 226        |                           |     | Component Function Check .....                           | 265        |
| Diagnosis Procedure .....                            | 226        |                           |     | Diagnosis Procedure .....                                | 266        |
| Component Inspection .....                           | 227        |                           |     | Component Inspection .....                               | 269        |
| <b>P0116 ECT SENSOR</b> .....                        | <b>228</b> |                           |     | <b>P0139, P0159 HO2S2</b> .....                          | <b>272</b> |
| DTC Logic .....                                      | 228        |                           |     | DTC Logic .....  | 272        |
| Component Function Check .....                       | 229        |                           |     | Component Function Check .....                           | 273        |
| Diagnosis Procedure .....                            | 229        |                           |     | Diagnosis Procedure .....                                | 274        |
| Component Inspection .....                           | 229        |                           |     | Component Inspection .....                               | 276        |
| <b>P0117, P0118 ECT SENSOR</b> .....                 | <b>231</b> |                           |     | <b>P0171, P0174 FUEL INJECTION SYSTEM FUNCTION</b> ..... | <b>279</b> |
| DTC Logic .....                                      | 231        |                           |     | DTC Logic .....  | 279        |
| Diagnosis Procedure .....                            | 231        |                           |     | Diagnosis Procedure .....                                | 280        |
| Component Inspection .....                           | 232        |                           |     | <b>P0172, P0175 FUEL INJECTION SYSTEM FUNCTION</b> ..... | <b>283</b> |
| <b>P0122, P0123, P0227, P0228 TP SENSOR</b> ...      | <b>233</b> |                           |     | DTC Logic .....  | 283        |
| DTC Logic .....                                      | 233        |                           |     | Diagnosis Procedure .....                                | 284        |
| Diagnosis Procedure .....                            | 233        |                           |     | <b>P0181 FTT SENSOR</b> .....                            | <b>287</b> |
| Component Inspection .....                           | 235        |                           |     | DTC Logic .....  | 287        |
| Special Repair Requirement .....                     | 235        |                           |     | Component Function Check .....                           | 288        |
| <b>P0125 ECT SENSOR</b> .....                        | <b>236</b> |                           |     | Diagnosis Procedure .....                                | 289        |
| DTC Logic .....                                      | 236        |                           |     | Component Inspection .....                               | 290        |
| Diagnosis Procedure .....                            | 236        |                           |     | <b>P0182, P0183 FTT SENSOR</b> .....                     | <b>291</b> |
| Component Inspection .....                           | 237        |                           |     | DTC Logic .....  | 291        |
| <b>P0127 IAT SENSOR</b> .....                        | <b>238</b> |                           |     | Diagnosis Procedure .....                                | 291        |
| DTC Logic .....                                      | 238        |                           |     | Component Inspection .....                               | 292        |
| Diagnosis Procedure .....                            | 238        |                           |     | <b>P0196 EOT SENSOR</b> .....                            | <b>294</b> |
| Component Inspection .....                           | 239        |                           |     | DTC Logic .....  | 294        |
| <b>P0128 THERMOSTAT FUNCTION</b> .....               | <b>240</b> |                           |     | Component Function Check .....                           | 296        |
| DTC Logic .....                                      | 240        |                           |     | Diagnosis Procedure .....                                | 296        |
| Diagnosis Procedure .....                            | 241        |                           |     | Component Inspection .....                               | 296        |
| Component Inspection .....                           | 241        |                           |     | <b>P0197, P0198 EOT SENSOR</b> .....                     | <b>298</b> |
| <b>P0130, P0150 A/F SENSOR 1</b> .....               | <b>243</b> |                           |     | DTC Logic .....  | 298        |
| DTC Logic .....                                      | 243        |                           |     | Diagnosis Procedure .....                                | 298        |
| Component Function Check .....                       | 244        |                           |     | Component Inspection .....                               | 299        |
| Diagnosis Procedure .....                            | 245        |                           |     | <b>P0222, P0223, P2132, P2133 TP SENSOR</b> ....         | <b>300</b> |
| <b>P0131, P0151 A/F SENSOR 1</b> .....               | <b>247</b> |                           |     |  |            |

|   |            |  |            |    |
|---|------------|--|------------|----|
| DTC Logic .....   | 300        | <b>P0451 EVAP CONTROL SYSTEM PRES-<br/>SURE SENSOR</b> ..... | <b>346</b> | A  |
| Diagnosis Procedure .....   | 300        | DTC Logic .....  | 346        |    |
| Component Inspection .....  | 302        | Diagnosis Procedure .....                                    | 347        |    |
| Special Repair Requirement .....  | 302        | Component Inspection .....                                   | 349        | EC |
| <b>P0300, P0301, P0302, P0303, P0304, P0305,<br/>P0306 MISFIRE</b> .....        | <b>303</b> | <b>P0452 EVAP CONTROL SYSTEM PRES-<br/>SURE SENSOR</b> ..... | <b>350</b> | C  |
| DTC Logic .....   | 303        | DTC Logic .....  | 350        |    |
| Diagnosis Procedure .....   | 304        | Diagnosis Procedure .....                                    | 351        |    |
| <b>P0327, P0328, P0332, P0333 KS</b> .....                                      | <b>309</b> | Component Inspection .....                                   | 353        | D  |
| DTC Logic .....   | 309        | <b>P0453 EVAP CONTROL SYSTEM PRES-<br/>SURE SENSOR</b> ..... | <b>355</b> | E  |
| Diagnosis Procedure .....   | 309        | DTC Logic .....  | 355        |    |
| Component Inspection .....  | 310        | Diagnosis Procedure .....                                    | 356        |    |
| <b>P0335 CKP SENSOR (POS)</b> .....   | <b>312</b> | Component Inspection .....                                   | 359        | F  |
| DTC Logic .....   | 312        | <b>P0456 EVAP CONTROL SYSTEM</b> .....                       | <b>360</b> | G  |
| Diagnosis Procedure .....   | 312        | DTC Logic .....  | 360        |    |
| Component Inspection .....  | 314        | Diagnosis Procedure .....                                    | 361        |    |
| <b>P0340, P0345 CMP SENSOR (PHASE)</b> .....                                    | <b>316</b> | Component Inspection .....                                   | 364        | H  |
| DTC Logic .....   | 316        | <b>P0460 FUEL LEVEL SENSOR</b> .....                         | <b>366</b> | I  |
| Diagnosis Procedure .....   | 317        | DTC Logic .....  | 366        |    |
| Component Inspection .....  | 319        | Diagnosis Procedure .....                                    | 366        | J  |
| <b>P0420, P0430 THREE WAY CATALYST<br/>FUNCTION</b> .....                       | <b>321</b> | <b>P0461 FUEL LEVEL SENSOR</b> .....                         | <b>367</b> | K  |
| DTC Logic .....   | 321        | DTC Logic .....  | 367        |    |
| Component Function Check .....  | 322        | Component Function Check .....                               | 367        | L  |
| Diagnosis Procedure .....   | 323        | Diagnosis Procedure .....                                    | 368        |    |
| <b>P0441 EVAP CONTROL SYSTEM</b> .....  | <b>326</b> | <b>P0462, P0463 FUEL LEVEL SENSOR</b> .....                  | <b>369</b> | M  |
| DTC Logic .....   | 326        | DTC Logic .....  | 369        |    |
| Component Function Check .....  | 327        | Diagnosis Procedure .....                                    | 369        | N  |
| Diagnosis Procedure .....   | 328        | <b>P0500 VSS</b> .....                                       | <b>370</b> | O  |
| <b>P0443 EVAP CANISTER PURGE VOLUME<br/>CONTROL SOLENOID VALVE</b> .....        | <b>331</b> | Description .....  | 370        | P  |
| DTC Logic .....   | 331        | DTC Logic .....  | 370        |    |
| Diagnosis Procedure .....   | 332        | Component Function Check .....                               | 371        |    |
| Component Inspection .....  | 334        | Diagnosis Procedure .....                                    | 371        |    |
| <b>P0444, P0445 EVAP CANISTER PURGE<br/>VOLUME CONTROL SOLENOID VALVE</b> ..... | <b>335</b> | <b>P0506 ISC SYSTEM</b> .....                                | <b>372</b> |    |
| DTC Logic .....   | 335        | Description .....  | 372        |    |
| Diagnosis Procedure .....   | 335        | DTC Logic .....  | 372        |    |
| Component Inspection .....  | 336        | Diagnosis Procedure .....                                    | 372        |    |
| <b>P0447 EVAP CANISTER VENT CONTROL<br/>VALVE</b> .....                         | <b>338</b> | <b>P0507 ISC SYSTEM</b> .....                                | <b>374</b> |    |
| DTC Logic .....   | 338        | Description .....  | 374        |    |
| Diagnosis Procedure .....   | 338        | DTC Logic .....  | 374        |    |
| Component Inspection .....  | 340        | Diagnosis Procedure .....                                    | 374        |    |
| <b>P0448 EVAP CANISTER VENT CONTROL<br/>VALVE</b> .....                         | <b>342</b> | <b>P050A, P050E COLD START CONTROL</b> .....                 | <b>376</b> |    |
| DTC Logic .....   | 342        | Description .....  | 376        |    |
| Diagnosis Procedure .....   | 342        | DTC Logic .....  | 376        |    |
| Component Inspection .....  | 344        | Diagnosis Procedure .....                                    | 377        |    |
| <b>P0524 ENGINE OIL PRESSURE</b> .....  | <b>378</b> | <b>P0524 ENGINE OIL PRESSURE</b> .....                       | <b>378</b> |    |
| DTC Logic .....   | 378        | DTC Logic .....  | 378        |    |
| Diagnosis Procedure .....   | 379        | Diagnosis Procedure .....                                    | 379        |    |
| Component Inspection .....  | 380        | Component Inspection .....                                   | 380        |    |

|  |            |   |            |
|--|------------|---|------------|
| <b>P0550 PSP SENSOR</b> .....                | <b>381</b> | DTC Logic .....                             | 409        |
| DTC Logic .....                              | 381        | <b>P1211 TCS CONTROL UNIT</b> .....         | <b>410</b> |
| Diagnosis Procedure .....                    | 381        | Description .....                           | 410        |
| Component Inspection .....                   | 382        | DTC Logic .....                             | 410        |
| <b>P0603 ECM POWER SUPPLY</b> .....          | <b>383</b> | Diagnosis Procedure .....                   | 410        |
| Description .....                            | 383        | <b>P1212 TCS COMMUNICATION LINE</b> .....   | <b>411</b> |
| DTC Logic .....                              | 383        | Description .....                           | 411        |
| Diagnosis Procedure .....                    | 383        | DTC Logic .....                             | 411        |
| <b>P0605 ECM</b> .....                       | <b>385</b> | Diagnosis Procedure .....                   | 411        |
| DTC Logic .....                              | 385        | <b>P1217 ENGINE OVER TEMPERATURE</b> .....  | <b>412</b> |
| Diagnosis Procedure .....                    | 385        | DTC Logic .....                             | 412        |
| <b>P0607 ECM</b> .....                       | <b>387</b> | Component Function Check .....              | 412        |
| DTC Logic .....                              | 387        | Diagnosis Procedure .....                   | 413        |
| Diagnosis Procedure .....                    | 387        | <b>P1225, P1234 TP SENSOR</b> .....         | <b>416</b> |
| <b>P0643 SENSOR POWER SUPPLY</b> .....       | <b>388</b> | DTC Logic .....                             | 416        |
| DTC Logic .....                              | 388        | Diagnosis Procedure .....                   | 416        |
| Diagnosis Procedure .....                    | 388        | Special Repair Requirement .....            | 417        |
| <b>P0850 PNP SWITCH</b> .....                | <b>391</b> | <b>P1226, P1235 TP SENSOR</b> .....         | <b>418</b> |
| Description .....                            | 391        | DTC Logic .....                             | 418        |
| DTC Logic .....                              | 391        | Diagnosis Procedure .....                   | 418        |
| Component Function Check .....               | 392        | Special Repair Requirement .....            | 419        |
| Diagnosis Procedure .....                    | 392        | <b>P1233, P2101 ELECTRIC THROTTLE CON-</b>  |            |
| <b>P100A, P100B VVEL SYSTEM</b> .....        | <b>394</b> | <b>TROL FUNCTION</b> .....                  | <b>420</b> |
| DTC Logic .....                              | 394        | DTC Logic .....                             | 420        |
| Diagnosis Procedure .....                    | 394        | Diagnosis Procedure .....                   | 420        |
| Component Inspection (VVEL ACTUATOR MO-      |            | Component Inspection .....                  | 423        |
| TOR) .....                                   | 396        | Special Repair Requirement .....            | 423        |
| Component Inspection (VVEL ACTUATOR SUB      |            | <b>P1236, P2118 THROTTLE CONTROL MO-</b>    |            |
| ASSEMBLY) .....                              | 396        | <b>TOR</b> .....                            | <b>424</b> |
| Special Repair Requirement .....             | 397        | DTC Logic .....                             | 424        |
| <b>P1087, P1088 VVEL SYSTEM</b> .....        | <b>398</b> | Diagnosis Procedure .....                   | 424        |
| DTC Logic .....                              | 398        | Component Inspection .....                  | 425        |
| <b>P1089, P1092 VVEL CONTROL SHAFT PO-</b>   |            | Special Repair Requirement .....            | 425        |
| <b>SITION SENSOR</b> .....                   | <b>399</b> | <b>P1238, P2119 ELECTRIC THROTTLE CON-</b>  |            |
| DTC Logic .....                              | 399        | <b>TROL ACTUATOR</b> .....                  | <b>427</b> |
| Diagnosis Procedure .....                    | 399        | DTC Logic .....                             | 427        |
| Special Repair Requirement .....             | 401        | Diagnosis Procedure .....                   | 427        |
| <b>P1090, P1093 VVEL ACTUATOR MOTOR</b> .... | <b>402</b> | Special Repair Requirement .....            | 428        |
| DTC Logic .....                              | 402        | <b>P1239, P2135 TP SENSOR</b> .....         | <b>429</b> |
| Diagnosis Procedure .....                    | 402        | DTC Logic .....                             | 429        |
| Component Inspection (VVEL ACTUATOR MO-      |            | Diagnosis Procedure .....                   | 429        |
| TOR) .....                                   | 404        | Component Inspection .....                  | 430        |
| Component Inspection (VVEL ACTUATOR SUB      |            | Special Repair Requirement .....            | 431        |
| ASSEMBLY) .....                              | 404        | <b>P1290, P2100, P2103 THROTTLE CONTROL</b> |            |
| Special Repair Requirement .....             | 405        | <b>MOTOR RELAY</b> .....                    | <b>432</b> |
| <b>P1091 VVEL ACTUATOR MOTOR RELAY</b> ...   | <b>406</b> | DTC Logic .....                             | 432        |
| DTC Logic .....                              | 406        | Diagnosis Procedure .....                   | 432        |
| Diagnosis Procedure .....                    | 406        | <b>P1550 BATTERY CURRENT SENSOR</b> .....   | <b>434</b> |
| Component Inspection .....                   | 408        | DTC Logic .....                             | 434        |
| <b>P1148, P1168 CLOSED LOOP CONTROL</b> .... | <b>409</b> | Diagnosis Procedure .....                   | 434        |

|  |            |  |            |    |
|--|------------|--|------------|----|
| Component Inspection .....                                 | 437        | DTC Logic .....                                | 475        |    |
|  |            | Diagnosis Procedure .....                      | 475        | A  |
| <b>P1551, P1552 BATTERY CURRENT SEN-<br/>SOR .....</b>     | <b>438</b> | <b>P1606 VVEL CONTROL MODULE .....</b>         | <b>477</b> |    |
| DTC Logic .....  | 438        | DTC Logic .....                                | 477        | EC |
| Diagnosis Procedure .....                                  | 438        | Diagnosis Procedure .....                      | 477        |    |
| Component Inspection .....                                 | 441        | <b>P1607 VVEL CONTROL MODULE .....</b>         | <b>478</b> |    |
| <b>P1553 BATTERY CURRENT SENSOR .....</b>                  | <b>442</b> | DTC Logic .....                                | 478        | C  |
| DTC Logic .....  | 442        | Diagnosis Procedure .....                      | 478        |    |
| Diagnosis Procedure .....                                  | 442        | <b>P1608 VVEL SENSOR POWER SUPPLY .....</b>    | <b>479</b> |    |
| Component Inspection .....                                 | 445        | DTC Logic .....                                | 479        | D  |
| <b>P1554 BATTERY CURRENT SENSOR .....</b>                  | <b>446</b> | Diagnosis Procedure .....                      | 479        |    |
| DTC Logic .....  | 446        | Special Repair Requirement .....               | 480        | E  |
| Component Function Check .....                             | 446        | <b>P1805 BRAKE SWITCH .....</b>                | <b>482</b> |    |
| Diagnosis Procedure .....                                  | 447        | DTC Logic .....                                | 482        | F  |
| Component Inspection .....                                 | 449        | Diagnosis Procedure .....                      | 482        |    |
| <b>P1556, P1557 BATTERY TEMPERATURE<br/>SENSOR .....</b>   | <b>450</b> | Component Inspection (Stop Lamp Switch) .....  | 483        |    |
| DTC Logic .....  | 450        | <b>P2122, P2123 APP SENSOR .....</b>           | <b>485</b> |    |
| Diagnosis Procedure .....                                  | 450        | DTC Logic .....                                | 485        | G  |
| Component Inspection (Battery Temperature<br>Sensor) ..... | 452        | Diagnosis Procedure .....                      | 485        |    |
| <b>P1564 ASCD STEERING SWITCH .....</b>                    | <b>453</b> | Component Inspection .....                     | 487        | H  |
| DTC Logic .....  | 453        | Special Repair Requirement .....               | 487        |    |
| Diagnosis Procedure .....                                  | 453        | <b>P2127, P2128 APP SENSOR .....</b>           | <b>489</b> |    |
| Component Inspection .....                                 | 455        | DTC Logic .....                                | 489        | I  |
| <b>P1564 ICC STEERING SWITCH .....</b>                     | <b>456</b> | Diagnosis Procedure .....                      | 489        |    |
| DTC Logic .....  | 456        | Component Inspection .....                     | 492        | J  |
| Diagnosis Procedure .....                                  | 456        | Special Repair Requirement .....               | 492        |    |
| Component Inspection .....                                 | 458        | <b>P2138 APP SENSOR .....</b>                  | <b>494</b> |    |
| <b>P1568 ICC FUNCTION .....</b>                            | <b>460</b> | DTC Logic .....                                | 494        | K  |
| DTC Logic .....  | 460        | Diagnosis Procedure .....                      | 494        |    |
| Diagnosis Procedure .....                                  | 460        | Component Inspection .....                     | 497        |    |
| <b>P1572 ASCD BRAKE SWITCH .....</b>                       | <b>461</b> | Special Repair Requirement .....               | 498        | L  |
| Description .....  | 461        | <b>P2A00, P2A03 A/F SENSOR 1 .....</b>         | <b>499</b> |    |
| DTC Logic .....  | 461        | DTC Logic .....                                | 499        |    |
| Diagnosis Procedure .....                                  | 462        | Diagnosis Procedure .....                      | 499        | M  |
| Component Inspection (ASCD Brake Switch) .....             | 465        | <b>ASCD BRAKE SWITCH .....</b>                 | <b>503</b> |    |
| Component Inspection (Stop Lamp Switch) .....              | 465        | Component Function Check .....                 | 503        |    |
| <b>P1572 ICC BRAKE SWITCH .....</b>                        | <b>467</b> | Diagnosis Procedure .....                      | 503        | N  |
| DTC Logic .....  | 467        | Component Inspection (ASCD Brake Switch) ..... | 504        |    |
| Diagnosis Procedure .....                                  | 468        | <b>ASCD INDICATOR .....</b>                    | <b>505</b> |    |
| Component Inspection (ICC Brake Switch) .....              | 471        | Component Function Check .....                 | 505        | O  |
| Component Inspection (Stop Lamp Switch) .....              | 471        | Diagnosis Procedure .....                      | 505        |    |
| Component Inspection (ICC Brake Hold Relay) .....          | 472        | <b>COOLING FAN .....</b>                       | <b>506</b> |    |
| <b>P1574 ASCD VEHICLE SPEED SENSOR .....</b>               | <b>473</b> | Component Function Check .....                 | 506        | P  |
| Description .....  | 473        | Diagnosis Procedure .....                      | 506        |    |
| DTC Logic .....  | 473        | Component Inspection (Cooling Fan Motor) ..... | 508        |    |
| Diagnosis Procedure .....                                  | 473        | Component Inspection (Cooling Fan Relay) ..... | 509        |    |
| <b>P1574 ICC VEHICLE SPEED SENSOR .....</b>                | <b>475</b> | <b>ELECTRICAL LOAD SIGNAL .....</b>            | <b>510</b> |    |
| Description .....  | 475        | Description .....                              | 510        |    |
|  |            | Component Function Check .....                 | 510        |    |
|  |            | Diagnosis Procedure .....                      | 510        |    |

|  |            |   |            |
|--|------------|---|------------|
| <b>FUEL INJECTOR</b> .....                     | <b>512</b> | <b>ECM</b> .....                                      | <b>543</b> |
| Component Function Check .....                 | 512        | Removal and Installation .....                        | 543        |
| Diagnosis Procedure .....                      | 512        | <b>VVEL CONTROL MODULE</b> .....                      | <b>544</b> |
| Component Inspection .....                     | 513        | Removal and Installation .....                        | 544        |
| <b>FUEL PUMP</b> .....                         | <b>514</b> | <b>SERVICE DATA AND SPECIFICATIONS</b>                |            |
| Component Function Check .....                 | 514        | <b>(SDS)</b> .....                                    | <b>545</b> |
| Diagnosis Procedure .....                      | 514        | <b>SERVICE DATA AND SPECIFICATIONS</b>                |            |
| Component Inspection .....                     | 516        | <b>(SDS)</b> .....                                    | <b>545</b> |
| <b>ICC BRAKE SWITCH</b> .....                  | <b>517</b> | Idle Speed .....                                      | 545        |
| Component Function Check .....                 | 517        | Ignition Timing .....                                 | 545        |
| Diagnosis Procedure .....                      | 517        | Calculated Load Value .....                           | 545        |
| Component Inspection (ICC Brake Switch) .....  | 518        | Mass Air Flow Sensor .....                            | 545        |
| <b>IGNITION SIGNAL</b> .....                   | <b>519</b> | <b>VQ37VHR FOR MEXICO</b>                             |            |
| Component Function Check .....                 | 519        | <b>PRECAUTION</b> .....                               | <b>546</b> |
| Diagnosis Procedure .....                      | 519        | <b>PRECAUTIONS</b> .....                              | <b>546</b> |
| Component Inspection (Ignition Coil with Power |            | Precaution for Supplemental Restraint System          |            |
| Transistor) .....                              | 522        | (SRS) "AIR BAG" and "SEAT BELT PRE-TEN-               |            |
| Component Inspection (Condenser) .....         | 523        | SIONER" .....   | 546        |
| <b>MALFUNCTION INDICATOR LAMP</b> .....        | <b>524</b> | Precaution for Procedure without Cowl Top Cover ..... | 546        |
| Component Function Check .....                 | 524        | Precautions For Xenon Headlamp Service .....          | 546        |
| Diagnosis Procedure .....                      | 524        | On Board Diagnostic (OBD) System of Engine            |            |
| <b>ON BOARD REFUELING VAPOR RECOV-</b>         |            | and A/T .....   | 547        |
| <b>ERY (ORVR)</b> .....                        | <b>525</b> | General Precautions .....                             | 547        |
| Component Function Check .....                 | 525        | <b>PREPARATION</b> .....                              | <b>551</b> |
| Diagnosis Procedure .....                      | 525        | <b>PREPARATION</b> .....                              | <b>551</b> |
| Component Inspection .....                     | 527        | Special Service Tools .....                           | 551        |
| <b>REFRIGERANT PRESSURE SENSOR</b> .....       | <b>530</b> | Commercial Service Tools .....                        | 551        |
| Component Function Check .....                 | 530        | <b>SYSTEM DESCRIPTION</b> .....                       | <b>553</b> |
| Diagnosis Procedure .....                      | 530        | <b>COMPONENT PARTS</b> .....                          | <b>553</b> |
| <b>SYMPTOM DIAGNOSIS</b> .....                 | <b>532</b> | <b>ENGINE CONTROL SYSTEM</b> .....                    | <b>553</b> |
| <b>ENGINE CONTROL SYSTEM SYMPTOMS</b> ..       | <b>532</b> | ENGINE CONTROL SYSTEM : Component Parts               |            |
| Symptom Table .....                            | 532        | Location .....  | 553        |
| <b>Infiniti Drive Mode Selector</b> .....      | <b>536</b> | ENGINE CONTROL SYSTEM : Component De-                 |            |
| Symptom Table .....                            | 536        | scription .....                                       | 556        |
| <b>NORMAL OPERATING CONDITION</b> .....        | <b>537</b> | <b>INFINITI DRIVE MODE SELECTOR</b> .....             | <b>557</b> |
| Description .....                              | 537        | Infiniti Drive Mode Selector : Component Parts Lo-    |            |
| <b>PERIODIC MAINTENANCE</b> .....              | <b>538</b> | cation .....  | 558        |
| <b>IDLE SPEED</b> .....                        | <b>538</b> | Infiniti Drive Mode Selector : Component Descrip-     |            |
| Inspection .....                               | 538        | tion .....  | 558        |
| <b>IGNITION TIMING</b> .....                   | <b>539</b> | Accelerator Pedal Position Sensor .....               | 559        |
| Inspection .....                               | 539        | Air Fuel Ratio Sensor 1 .....                         | 559        |
| <b>EVAP LEAK CHECK</b> .....                   | <b>540</b> | Air Fuel Ratio Sensor 1 Heater .....                  | 559        |
| Inspection .....                               | 540        | ASCD Brake Switch .....                               | 559        |
| <b>POSITIVE CRANKCASE VENTILATION</b> .....    | <b>542</b> | ASCD Indicator .....                                  | 560        |
| Inspection .....                               | 542        | ASCD Steering Switch .....                            | 560        |
| <b>REMOVAL AND INSTALLATION</b> .....          | <b>543</b> | Battery Current Sensor (With Battery Tempera-         |            |
|  |            | ture Sensor) .....                                    | 560        |
|  |            | Brake Switch .....                                    | 560        |
|  |            | Camshaft Position Sensor (PHASE) .....                | 561        |
|  |            | Cooling Fan .....                                     | 561        |



|   |            |   |            |    |
|---|------------|---|------------|----|
| Crankshaft Position Sensor (POS) .....                      | 561        | AIR CONDITIONING CUT CONTROL : System Description .....                             | 577        | A  |
| ECM .....   | 562        | <b>AUTOMATIC SPEED CONTROL DEVICE (ASCD) ..577</b>                                  |            |    |
| Electric Throttle Control Actuator .....                    | 562        | AUTOMATIC SPEED CONTROL DEVICE (AS-CD) : System Diagram .....                       | 578        | EC |
| Engine Coolant Temperature Sensor .....                     | 562        | AUTOMATIC SPEED CONTROL DEVICE (AS-CD) : System Description .....                   | 578        |    |
| Engine Oil Temperature Sensor .....                         | 563        | <b>CAN COMMUNICATION .....</b>  | <b>579</b> | C  |
| EVAP Canister Purge Volume Control Solenoid Valve .....     | 563        | CAN COMMUNICATION : System Description .....  | 579        |    |
| EVAP Canister Vent Control Valve .....                      | 563        | <b>COOLING FAN CONTROL .....</b>  | <b>579</b> | D  |
| EVAP Control System Pressure Sensor .....                   | 564        | COOLING FAN CONTROL : System Diagram .....  | 579        |    |
| Fuel Injector .....   | 564        | COOLING FAN CONTROL : System Description .....                                      | 579        | E  |
| Fuel Level Sensor .....                                     | 564        | <b>EVAPORATIVE EMISSION SYSTEM .....</b>  | <b>580</b> | F  |
| Fuel Pump .....   | 564        | EVAPORATIVE EMISSION SYSTEM : System Diagram .....                                  | 580        |    |
| Fuel Tank Temperature Sensor .....                          | 565        | EVAPORATIVE EMISSION SYSTEM : System Description .....                              | 580        | G  |
| Heated Oxygen Sensor 2 .....                                | 565        | <b>ENGINE PROTECTION CONTROL AT LOW ENGINE OIL PRESSURE .....</b>                   | <b>581</b> | H  |
| Heated Oxygen Sensor 2 Heater .....                         | 565        | ENGINE PROTECTION CONTROL AT LOW ENGINE OIL PRESSURE : System Diagram .....         | 581        |    |
| Ignition Coil .....   | 565        | ENGINE PROTECTION CONTROL AT LOW ENGINE OIL PRESSURE : System Description .....     | 582        | I  |
| Intake Air Temperature Sensor .....                         | 566        | <b>INTAKE VALVE TIMING CONTROL .....</b>  | <b>582</b> | J  |
| Intake Valve Timing Control Solenoid Valve .....            | 566        | INTAKE VALVE TIMING CONTROL : System Diagram .....                                  | 582        |    |
| ICC Brake Switch .....                                      | 566        | INTAKE VALVE TIMING CONTROL : System Description .....                              | 582        | K  |
| ICC Steering Switch .....                                   | 566        | <b>VVEL SYSTEM .....</b>  | <b>583</b> |    |
| Knock Sensor .....  | 566        | VVEL SYSTEM : System Diagram .....  | 583        |    |
| Manifold Absolute Pressure Sensor .....                     | 567        | VVEL SYSTEM : System Description .....  | 583        | L  |
| Malfunction Indicator Lamp .....                            | 567        | <b>INFINITI DRIVE MODE SELECTOR .....</b>   | <b>584</b> |    |
| Mass Air Flow Sensor .....                                  | 567        | Infiniti Drive Mode Selector : System Description .....                             | 585        | M  |
| Power Steering Pressure Sensor .....                        | 567        | <b>OPERATION .....</b>  | <b>587</b> |    |
| Refrigerant Pressure Sensor .....                           | 568        | <b>AUTOMATIC SPEED CONTROL DEVICE (ASCD) ..587</b>                                  |            | N  |
| Throttle Control Motor .....                                | 568        | AUTOMATIC SPEED CONTROL DEVICE (ASCD) : Switch Name and Function .....              | 587        |    |
| Throttle Control Motor Relay .....                          | 568        | <b>HANDLING PRECAUTION .....</b>  | <b>589</b> |    |
| Throttle Position Sensor .....                              | 568        | Infiniti Drive Mode Selector .....  | 589        | O  |
| VVEL Actuator Motor .....                                   | 568        | <b>ON BOARD DIAGNOSTIC (OBD) SYSTEM ..</b>  | <b>590</b> |    |
| VVEL Actuator Motor Relay .....                             | 568        | Diagnosis Description .....   | 590        |    |
| VVEL Control Module .....                                   | 569        | GST (Generic Scan Tool) .....   | 590        | P  |
| VVEL Control Position Sensor .....                          | 569        | <b>DIAGNOSIS SYSTEM (ECM) .....</b>   | <b>591</b> |    |
| <b>STRUCTURE AND OPERATION .....</b>                        | <b>570</b> | <b>DIAGNOSIS DESCRIPTION .....</b>  | <b>591</b> |    |
| Positive Crankcase Ventilation .....                        | 570        | DIAGNOSIS DESCRIPTION : 1st Trip Detection Logic and Two Trip Detection Logic ..... | 591        |    |
| On Board Refueling Vapor Recovery (ORVR) .....              | 571        | DIAGNOSIS DESCRIPTION : DTC and Freeze Frame Data .....                             | 591        |    |
| <b>SYSTEM .....</b>   | <b>572</b> | DIAGNOSIS DESCRIPTION : Counter System .....  | 592        |    |
| <b>ENGINE CONTROL SYSTEM .....</b>                          | <b>572</b> |   |            |    |
| ENGINE CONTROL SYSTEM : System Diagram .....                | 572        |   |            |    |
| ENGINE CONTROL SYSTEM : System Description .....            | 573        |   |            |    |
| <b>MULTIPOINT FUEL INJECTION SYSTEM .....</b>               | <b>573</b> |   |            |    |
| MULTIPOINT FUEL INJECTION SYSTEM : System Diagram .....     | 573        |   |            |    |
| MULTIPOINT FUEL INJECTION SYSTEM : System Description ..... | 573        |   |            |    |
| <b>ELECTRIC IGNITION SYSTEM .....</b>                       | <b>576</b> |   |            |    |
| ELECTRIC IGNITION SYSTEM : System Diagram .....             | 576        |   |            |    |
| ELECTRIC IGNITION SYSTEM : System Description .....         | 576        |   |            |    |
| <b>AIR CONDITIONING CUT CONTROL .....</b>                   | <b>577</b> |   |            |    |
| AIR CONDITIONING CUT CONTROL : System Diagram .....         | 577        |   |            |    |

|   |            |  |            |
|---|------------|--|------------|
| DIAGNOSIS DESCRIPTION : Driving Pattern ..... | 595        | Work Procedure .....                           | 660        |
| DIAGNOSIS DESCRIPTION : System Readiness      |            | <b>MIXTURE RATIO SELF-LEARNING VALUE</b>       |            |
| Test (SRT) Code .....                         | 596        | <b>CLEAR .....</b>                             | <b>662</b> |
| DIAGNOSIS DESCRIPTION : Malfunction Indica-   |            | Description .....                              | 662        |
| tor Lamp (MIL) .....                          | 597        | Work Procedure .....                           | 662        |
| On Board Diagnosis Function .....             | 598        | <b>BASIC INSPECTION .....</b>                  | <b>663</b> |
| CONSULT Function .....                        | 601        | Work Procedure .....                           | 663        |
| <b>ECU DIAGNOSIS INFORMATION .....</b>        | <b>609</b> | <b>FUEL PRESSURE CHECK .....</b>               | <b>667</b> |
| <b>ECM .....</b>                              | <b>609</b> | Work Procedure .....                           | 667        |
| Reference Value .....                         | 609        | <b>HOW TO SET SRT CODE .....</b>               | <b>669</b> |
| Fail safe .....                               | 625        | Description .....                              | 669        |
| DTC Inspection Priority Chart .....           | 627        | SRT Set Driving Pattern .....                  | 670        |
| DTC Index .....                               | 628        | Work Procedure .....                           | 672        |
| Test Value and Test Limit .....               | 632        | <b>DTC/CIRCUIT DIAGNOSIS .....</b>             | <b>674</b> |
| <b>VVEL CONTROL MODULE .....</b>              | <b>639</b> | <b>TROUBLE DIAGNOSIS - SPECIFICATION</b>       |            |
| Reference Value .....                         | 639        | <b>VALUE .....</b>                             | <b>674</b> |
| <b>WIRING DIAGRAM .....</b>                   | <b>643</b> | Description .....                              | 674        |
| <b>ENGINE CONTROL SYSTEM .....</b>            | <b>643</b> | Component Function Check .....                 | 674        |
| Wiring Diagram .....                          | 643        | Diagnosis Procedure .....                      | 675        |
| <b>BASIC INSPECTION .....</b>                 | <b>649</b> | <b>POWER SUPPLY AND GROUND CIRCUIT ...</b>     | <b>682</b> |
| <b>DIAGNOSIS AND REPAIR WORKFLOW .....</b>    | <b>649</b> | Diagnosis Procedure .....                      | 682        |
| Work Flow .....                               | 649        | <b>POWER SUPPLY AND GROUND CIRCUIT</b>         |            |
| Diagnostic Work Sheet .....                   | 651        | <b>(VVEL CONTROL MODULE) .....</b>             | <b>685</b> |
| <b>ADDITIONAL SERVICE WHEN REPLACING</b>      |            | Diagnosis Procedure .....                      | 685        |
| <b>ECM .....</b>                              | <b>653</b> | <b>U0101 CAN COMM CIRCUIT .....</b>            | <b>687</b> |
| Description .....                             | 653        | Description .....                              | 687        |
| Work Procedure .....                          | 653        | DTC Logic .....                                | 687        |
| <b>ADDITIONAL SERVICE WHEN REPLACING</b>      |            | Diagnosis Procedure .....                      | 687        |
| <b>VVEL CONTROL MODULE .....</b>              | <b>654</b> | <b>U1001 CAN COMM CIRCUIT .....</b>            | <b>688</b> |
| Description .....                             | 654        | Description .....                              | 688        |
| Work Procedure .....                          | 654        | DTC Logic .....                                | 688        |
| <b>VIN REGISTRATION .....</b>                 | <b>655</b> | Diagnosis Procedure .....                      | 688        |
| Description .....                             | 655        | <b>U1003 CAN COMM CIRCUIT .....</b>            | <b>689</b> |
| Work Procedure .....                          | 655        | Description .....                              | 689        |
| <b>ACCELERATOR PEDAL RELEASED POSI-</b>       |            | DTC Logic .....                                | 689        |
| <b>TION LEARNING .....</b>                    | <b>656</b> | Diagnosis Procedure .....                      | 689        |
| Description .....                             | 656        | <b>U1024 CAN COMM CIRCUIT .....</b>            | <b>691</b> |
| Work Procedure .....                          | 656        | Description .....                              | 691        |
| <b>THROTTLE VALVE CLOSED POSITION</b>         |            | DTC Logic .....                                | 691        |
| <b>LEARNING .....</b>                         | <b>657</b> | Diagnosis Procedure .....                      | 691        |
| Description .....                             | 657        | <b>P0011, P0021 IVT CONTROL .....</b>          | <b>693</b> |
| Work Procedure .....                          | 657        | DTC Logic .....                                | 693        |
| <b>IDLE AIR VOLUME LEARNING .....</b>         | <b>658</b> | Diagnosis Procedure .....                      | 694        |
| Description .....                             | 658        | Component Inspection .....                     | 695        |
| Work Procedure .....                          | 658        | <b>P0031, P0032, P0051, P0052 A/F SENSOR 1</b> |            |
| <b>VVEL CONTROL SHAFT POSITION SEN-</b>       |            | <b>HEATER .....</b>                            | <b>697</b> |
| <b>SOR ADJUSTMENT .....</b>                   | <b>660</b> | DTC Logic .....                                | 697        |
| Description .....                             | 660        | Diagnosis Procedure .....                      | 697        |

|   |            |  |            |    |
|---|------------|--|------------|----|
| Component Inspection .....                            | 699        | Diagnosis Procedure .....  | 742        |    |
| <b>P0037, P0038, P0057, P0058 HO2S2 HEAT-ER</b> ..... | <b>700</b> | Component Inspection .....   | 745        | A  |
| DTC Logic .....                                       | 700        | <b>P0139, P0159 HO2S2</b> .....                                      | <b>748</b> |    |
| Diagnosis Procedure .....                             | 700        | DTC Logic .....  | 748        | EC |
| Component Inspection .....                            | 702        | Component Function Check .....                                       | 749        |    |
| <b>P0075, P0081 IVT CONTROL SOLENOID VALVE</b> .....  | <b>703</b> | Diagnosis Procedure .....  | 750        | C  |
| DTC Logic .....                                       | 703        | Component Inspection .....   | 751        |    |
| Diagnosis Procedure .....                             | 703        | <b>P0171, P0174 FUEL INJECTION SYSTEM FUNCTION</b> .....             | <b>754</b> | D  |
| Component Inspection .....                            | 704        | DTC Logic .....  | 754        |    |
| <b>P0102, P0103, P010C, P010D MAF SENSOR</b> .....    | <b>706</b> | Diagnosis Procedure .....  | 755        | E  |
| DTC Logic .....                                       | 706        | <b>P0172, P0175 FUEL INJECTION SYSTEM FUNCTION</b> .....             | <b>758</b> |    |
| Diagnosis Procedure .....                             | 706        | DTC Logic .....  | 758        | F  |
| Component Inspection .....                            | 708        | Diagnosis Procedure .....  | 759        |    |
| <b>P0112, P0113 IAT SENSOR</b> .....                  | <b>712</b> | <b>P0182, P0183 FTT SENSOR</b> .....                                 | <b>762</b> | G  |
| DTC Logic .....                                       | 712        | DTC Logic .....  | 762        |    |
| Diagnosis Procedure .....                             | 712        | Diagnosis Procedure .....  | 762        | H  |
| Component Inspection .....                            | 713        | Component Inspection .....   | 763        |    |
| <b>P0117, P0118 ECT SENSOR</b> .....                  | <b>714</b> | <b>P0197, P0198 EOT SENSOR</b> .....                                 | <b>765</b> | I  |
| DTC Logic .....                                       | 714        | DTC Logic .....  | 765        |    |
| Diagnosis Procedure .....                             | 714        | Diagnosis Procedure .....  | 765        | J  |
| Component Inspection .....                            | 715        | Component Inspection .....   | 766        |    |
| <b>P0122, P0123, P0227, P0228 TP SENSOR</b> ....      | <b>716</b> | <b>P0222, P0223, P2132, P2133 TP SENSOR</b> ...                      | <b>767</b> | K  |
| DTC Logic .....                                       | 716        | DTC Logic .....  | 767        |    |
| Diagnosis Procedure .....                             | 716        | Diagnosis Procedure .....  | 767        | L  |
| Component Inspection .....                            | 718        | Component Inspection .....   | 769        |    |
| Special Repair Requirement .....                      | 718        | Special Repair Requirement .....                                     | 769        | M  |
| <b>P0130, P0150 A/F SENSOR 1</b> .....                | <b>719</b> | <b>P0300, P0301, P0302, P0303, P0304, P0305, P0306 MISFIRE</b> ..... | <b>770</b> | N  |
| DTC Logic .....                                       | 719        | DTC Logic .....  | 770        |    |
| Component Function Check .....                        | 720        | Diagnosis Procedure .....  | 771        | O  |
| Diagnosis Procedure .....                             | 721        | <b>P0327, P0328, P0332, P0333 KS</b> .....                           | <b>776</b> |    |
| <b>P0131, P0151 A/F SENSOR 1</b> .....                | <b>723</b> | DTC Logic .....  | 776        | P  |
| DTC Logic .....                                       | 723        | Diagnosis Procedure .....  | 776        |    |
| Diagnosis Procedure .....                             | 724        | Component Inspection .....   | 777        |    |
| <b>P0132, P0152 A/F SENSOR 1</b> .....                | <b>726</b> | <b>P0335 CKP SENSOR (POS)</b> .....                                  | <b>779</b> |    |
| DTC Logic .....                                       | 726        | DTC Logic .....  | 779        |    |
| Diagnosis Procedure .....                             | 727        | Diagnosis Procedure .....  | 779        |    |
| <b>P0133, P0153 A/F SENSOR 1</b> .....                | <b>729</b> | Component Inspection .....   | 781        |    |
| DTC Logic .....                                       | 729        | <b>P0340, P0345 CMP SENSOR (PHASE)</b> .....                         | <b>783</b> |    |
| Diagnosis Procedure .....                             | 730        | DTC Logic .....  | 783        |    |
| <b>P0137, P0157 HO2S2</b> .....                       | <b>734</b> | Diagnosis Procedure .....  | 784        |    |
| DTC Logic .....                                       | 734        | Component Inspection .....   | 786        |    |
| Component Function Check .....                        | 735        | <b>P0420, P0430 THREE WAY CATALYST FUNCTION</b> .....                | <b>788</b> |    |
| Diagnosis Procedure .....                             | 736        | DTC Logic .....  | 788        |    |
| Component Inspection .....                            | 737        | Component Function Check .....                                       | 789        |    |
| <b>P0138, P0158 HO2S2</b> .....                       | <b>740</b> | Diagnosis Procedure .....  | 790        |    |
| DTC Logic .....                                       | 740        |  |            |    |
| Component Function Check .....                        | 741        |  |            |    |

|   |            |  |            |
|---|------------|--|------------|
| <b>P0444, P0445 EVAP CANISTER PURGE VOLUME CONTROL SOLENOID VALVE</b> ..... | <b>793</b> | Diagnosis Procedure .....                                    | 826        |
| DTC Logic .....   | 793        | <b>P100A, P100B VVEL SYSTEM</b> .....                        | <b>828</b> |
| Diagnosis Procedure .....   | 793        | DTC Logic .....  | 828        |
| Component Inspection .....  | 794        | Diagnosis Procedure .....                                    | 828        |
| <b>P0447 EVAP CANISTER VENT CONTROL VALVE</b> .....                         | <b>796</b> | Component Inspection (VVEL ACTUATOR MOTOR) .....             | 830        |
| DTC Logic .....   | 796        | Component Inspection (VVEL ACTUATOR SUB ASSEMBLY) .....      | 830        |
| Diagnosis Procedure .....   | 796        | Special Repair Requirement .....                             | 831        |
| Component Inspection .....  | 798        | <b>P1087, P1088 VVEL SYSTEM</b> .....                        | <b>832</b> |
| <b>P0452 EVAP CONTROL SYSTEM PRES-SURE SENSOR</b> .....                     | <b>800</b> | DTC Logic .....  | 832        |
| DTC Logic .....   | 800        | <b>P1089, P1092 VVEL CONTROL SHAFT POSITION SENSOR</b> ..... | <b>833</b> |
| Diagnosis Procedure .....   | 801        | DTC Logic .....  | 833        |
| Component Inspection .....  | 803        | Diagnosis Procedure .....                                    | 833        |
| <b>P0453 EVAP CONTROL SYSTEM PRES-SURE SENSOR</b> .....                     | <b>805</b> | Special Repair Requirement .....                             | 835        |
| DTC Logic .....   | 805        | <b>P1090, P1093 VVEL ACTUATOR MOTOR</b> ....                 | <b>836</b> |
| Diagnosis Procedure .....   | 806        | DTC Logic .....  | 836        |
| Component Inspection .....  | 809        | Diagnosis Procedure .....                                    | 836        |
| <b>P0500 VSS</b> .....  | <b>810</b> | Component Inspection (VVEL ACTUATOR MOTOR) .....             | 838        |
| Description .....   | 810        | Component Inspection (VVEL ACTUATOR SUB ASSEMBLY) .....      | 838        |
| DTC Logic .....   | 810        | Special Repair Requirement .....                             | 839        |
| Component Function Check .....  | 811        | <b>P1091 VVEL ACTUATOR MOTOR RELAY</b> ....                  | <b>840</b> |
| Diagnosis Procedure .....   | 811        | DTC Logic .....  | 840        |
| <b>P0524 ENGINE OIL PRESSURE</b> .....                                      | <b>812</b> | Diagnosis Procedure .....                                    | 840        |
| DTC Logic .....   | 812        | Component Inspection .....                                   | 842        |
| Diagnosis Procedure .....   | 813        | <b>P1211 TCS CONTROL UNIT</b> .....                          | <b>843</b> |
| Component Inspection .....  | 814        | Description .....  | 843        |
| <b>P0550 PSP SENSOR</b> .....   | <b>815</b> | DTC Logic .....  | 843        |
| DTC Logic .....   | 815        | Diagnosis Procedure .....                                    | 843        |
| Diagnosis Procedure .....   | 815        | <b>P1212 TCS COMMUNICATION LINE</b> .....                    | <b>844</b> |
| Component Inspection .....  | 816        | Description .....  | 844        |
| <b>P0603 ECM POWER SUPPLY</b> .....   | <b>817</b> | DTC Logic .....  | 844        |
| Description .....   | 817        | Diagnosis Procedure .....                                    | 844        |
| DTC Logic .....   | 817        | <b>P1217 ENGINE OVER TEMPERATURE</b> .....                   | <b>845</b> |
| Diagnosis Procedure .....   | 817        | DTC Logic .....  | 845        |
| <b>P0605 ECM</b> .....  | <b>819</b> | Component Function Check .....                               | 845        |
| DTC Logic .....   | 819        | Diagnosis Procedure .....                                    | 846        |
| Diagnosis Procedure .....   | 819        | <b>P1225, P1234 TP SENSOR</b> .....                          | <b>849</b> |
| <b>P0607 ECM</b> .....  | <b>821</b> | DTC Logic .....  | 849        |
| DTC Logic .....   | 821        | Diagnosis Procedure .....                                    | 849        |
| Diagnosis Procedure .....   | 821        | Special Repair Requirement .....                             | 850        |
| <b>P0643 SENSOR POWER SUPPLY</b> .....                                      | <b>822</b> | <b>P1226, P1235 TP SENSOR</b> .....                          | <b>851</b> |
| DTC Logic .....   | 822        | DTC Logic .....  | 851        |
| Diagnosis Procedure .....   | 822        | Diagnosis Procedure .....                                    | 851        |
| <b>P0850 PNP SWITCH</b> .....   | <b>825</b> | Special Repair Requirement .....                             | 852        |
| Description .....   | 825        | <b>P1233, P2101 ELECTRIC THROTTLE CONTROL FUNCTION</b> ..... | <b>853</b> |
| DTC Logic .....   | 825        |  |            |
| Component Function Check .....  | 826        |  |            |

|   |            |   |            |    |
|---|------------|---|------------|----|
| DTC Logic .....                             | 853        | Component Inspection .....                        | 888        | A  |
| Diagnosis Procedure .....                   | 853        | <b>P1564 ICC STEERING SWITCH .....</b>            | <b>889</b> |    |
| Component Inspection .....                  | 856        | DTC Logic .....                                   | 889        |    |
| Special Repair Requirement .....            | 856        | Diagnosis Procedure .....                         | 889        |    |
| <b>P1236, P2118 THROTTLE CONTROL MO-</b>    |            | Component Inspection .....                        | 891        | EC |
| <b>TOR .....</b>                            | <b>857</b> | <b>P1568 ICC FUNCTION .....</b>                   | <b>893</b> |    |
| DTC Logic .....                             | 857        | DTC Logic .....                                   | 893        | C  |
| Diagnosis Procedure .....                   | 857        | Diagnosis Procedure .....                         | 893        |    |
| Component Inspection .....                  | 858        | <b>P1572 ASCD BRAKE SWITCH .....</b>              | <b>894</b> | D  |
| Special Repair Requirement .....            | 858        | Description .....                                 | 894        |    |
| <b>P1238, P2119 ELECTRIC THROTTLE CON-</b>  |            | DTC Logic .....                                   | 894        |    |
| <b>TROL ACTUATOR .....</b>                  | <b>860</b> | Diagnosis Procedure .....                         | 895        | E  |
| DTC Logic .....                             | 860        | Component Inspection (ASCD Brake Switch) .....    | 898        |    |
| Diagnosis Procedure .....                   | 860        | Component Inspection (Stop Lamp Switch) .....     | 898        |    |
| Special Repair Requirement .....            | 861        | <b>P1572 ICC BRAKE SWITCH .....</b>               | <b>900</b> | F  |
| <b>P1239, P2135 TP SENSOR .....</b>         | <b>862</b> | DTC Logic .....                                   | 900        |    |
| DTC Logic .....                             | 862        | Diagnosis Procedure .....                         | 901        | G  |
| Diagnosis Procedure .....                   | 862        | Component Inspection (ICC Brake Switch) .....     | 904        |    |
| Component Inspection .....                  | 863        | Component Inspection (Stop Lamp Switch) .....     | 904        |    |
| Special Repair Requirement .....            | 864        | Component Inspection (ICC Brake Hold Relay) ..... | 905        |    |
| <b>P1290, P2100, P2103 THROTTLE CONTROL</b> |            | <b>P1574 ASCD VEHICLE SPEED SENSOR .....</b>      | <b>906</b> | H  |
| <b>MOTOR RELAY .....</b>                    | <b>865</b> | Description .....                                 | 906        |    |
| DTC Logic .....                             | 865        | DTC Logic .....                                   | 906        | I  |
| Diagnosis Procedure .....                   | 865        | Diagnosis Procedure .....                         | 906        |    |
| <b>P1550 BATTERY CURRENT SENSOR .....</b>   | <b>867</b> | <b>P1574 ICC VEHICLE SPEED SENSOR .....</b>       | <b>908</b> | J  |
| DTC Logic .....                             | 867        | Description .....                                 | 908        |    |
| Diagnosis Procedure .....                   | 867        | DTC Logic .....                                   | 908        |    |
| Component Inspection .....                  | 870        | Diagnosis Procedure .....                         | 908        |    |
| <b>P1551, P1552 BATTERY CURRENT SEN-</b>    |            | <b>P1606 VVEL CONTROL MODULE .....</b>            | <b>910</b> | K  |
| <b>SOR .....</b>                            | <b>871</b> | DTC Logic .....                                   | 910        |    |
| DTC Logic .....                             | 871        | Diagnosis Procedure .....                         | 910        |    |
| Diagnosis Procedure .....                   | 871        | <b>P1607 VVEL CONTROL MODULE .....</b>            | <b>911</b> | L  |
| Component Inspection .....                  | 874        | DTC Logic .....                                   | 911        |    |
| <b>P1553 BATTERY CURRENT SENSOR .....</b>   | <b>875</b> | Diagnosis Procedure .....                         | 911        |    |
| DTC Logic .....                             | 875        | <b>P1608 VVEL SENSOR POWER SUPPLY .....</b>       | <b>912</b> | M  |
| Diagnosis Procedure .....                   | 875        | DTC Logic .....                                   | 912        |    |
| Component Inspection .....                  | 878        | Diagnosis Procedure .....                         | 912        |    |
| <b>P1554 BATTERY CURRENT SENSOR .....</b>   | <b>879</b> | Special Repair Requirement .....                  | 913        | N  |
| DTC Logic .....                             | 879        | <b>P1805 BRAKE SWITCH .....</b>                   | <b>915</b> |    |
| Component Function Check .....              | 879        | DTC Logic .....                                   | 915        | O  |
| Diagnosis Procedure .....                   | 880        | Diagnosis Procedure .....                         | 915        |    |
| Component Inspection .....                  | 882        | Component Inspection (Stop Lamp Switch) .....     | 916        |    |
| <b>P1556, P1557 BATTERY TEMPERATURE</b>     |            | <b>P2122, P2123 APP SENSOR .....</b>              | <b>918</b> | P  |
| <b>SENSOR .....</b>                         | <b>883</b> | DTC Logic .....                                   | 918        |    |
| DTC Logic .....                             | 883        | Diagnosis Procedure .....                         | 918        |    |
| Diagnosis Procedure .....                   | 883        | Component Inspection .....                        | 920        |    |
| Component Inspection (Battery Temperature   |            | Special Repair Requirement .....                  | 920        |    |
| Sensor) .....                               | 885        | <b>P2127, P2128 APP SENSOR .....</b>              | <b>922</b> |    |
| <b>P1564 ASCD STEERING SWITCH .....</b>     | <b>886</b> | DTC Logic .....                                   | 922        |    |
| DTC Logic .....                             | 886        | Diagnosis Procedure .....                         | 922        |    |
| Diagnosis Procedure .....                   | 886        |   |            |    |

|   |            |   |            |
|---|------------|---|------------|
| Component Inspection .....  | 925        | Component Function Check .....                              | 958        |
| Special Repair Requirement .....                                    | 925        | Diagnosis Procedure .....                                   | 958        |
| <b>P2138 APP SENSOR .....</b>                                       | <b>927</b> | Component Inspection .....                                  | 960        |
| DTC Logic .....   | 927        | <b>ON BOARD REFUELING VAPOR RECOV-<br/>ERY (ORVR) .....</b> | <b>962</b> |
| Diagnosis Procedure .....   | 927        | Component Function Check .....                              | 962        |
| Component Inspection .....  | 930        | Diagnosis Procedure .....                                   | 962        |
| Special Repair Requirement .....                                    | 931        | Component Inspection .....                                  | 964        |
| <b>P2A00, P2A03 A/F SENSOR 1 .....</b>                              | <b>932</b> | <b>REFRIGERANT PRESSURE SENSOR .....</b>                    | <b>967</b> |
| DTC Logic .....   | 932        | Component Function Check .....                              | 967        |
| Diagnosis Procedure .....   | 932        | Diagnosis Procedure .....                                   | 967        |
| <b>ASCD BRAKE SWITCH .....</b>                                      | <b>936</b> | <b>SYMPTOM DIAGNOSIS .....</b>                              | <b>969</b> |
| Component Function Check .....                                      | 936        | <b>ENGINE CONTROL SYSTEM SYMPTOMS ...</b>                   | <b>969</b> |
| Diagnosis Procedure .....   | 936        | Symptom Table .....   | 969        |
| Component Inspection (ASCD Brake Switch) .....                      | 937        | <b>Infiniti Drive Mode Selector .....</b>                   | <b>973</b> |
| <b>ASCD INDICATOR .....</b>   | <b>938</b> | Symptom Table .....   | 973        |
| Component Function Check .....                                      | 938        | <b>NORMAL OPERATING CONDITION .....</b>                     | <b>974</b> |
| Diagnosis Procedure .....   | 938        | Description .....   | 974        |
| <b>COOLING FAN .....</b>  | <b>939</b> | <b>PERIODIC MAINTENANCE .....</b>                           | <b>975</b> |
| Component Function Check .....                                      | 939        | <b>IDLE SPEED .....</b>                                     | <b>975</b> |
| Diagnosis Procedure .....   | 939        | Inspection .....  | 975        |
| Component Inspection (Cooling Fan Motor) .....                      | 941        | <b>IGNITION TIMING .....</b>                                | <b>976</b> |
| Component Inspection (Cooling Fan Relay) .....                      | 942        | Inspection .....  | 976        |
| <b>ELECTRICAL LOAD SIGNAL .....</b>                                 | <b>943</b> | <b>EVAP LEAK CHECK .....</b>                                | <b>977</b> |
| Description .....   | 943        | Inspection .....  | 977        |
| Component Function Check .....                                      | 943        | <b>POSITIVE CRANKCASE VENTILATION .....</b>                 | <b>979</b> |
| Diagnosis Procedure .....   | 943        | Inspection .....  | 979        |
| <b>FUEL INJECTOR .....</b>  | <b>945</b> | <b>REMOVAL AND INSTALLATION .....</b>                       | <b>980</b> |
| Component Function Check .....                                      | 945        | <b>ECM .....</b>  | <b>980</b> |
| Diagnosis Procedure .....   | 945        | Removal and Installation .....                              | 980        |
| Component Inspection .....  | 946        | <b>VVEL CONTROL MODULE .....</b>                            | <b>981</b> |
| <b>FUEL PUMP .....</b>  | <b>947</b> | Removal and Installation .....                              | 981        |
| Component Function Check .....                                      | 947        | <b>SERVICE DATA AND SPECIFICATIONS<br/>(SDS) .....</b>      | <b>982</b> |
| Diagnosis Procedure .....   | 947        | <b>SERVICE DATA AND SPECIFICATIONS<br/>(SDS) .....</b>      | <b>982</b> |
| Component Inspection .....  | 949        | Idle Speed .....  | 982        |
| <b>ICC BRAKE SWITCH .....</b>                                       | <b>950</b> | Ignition Timing .....                                       | 982        |
| Component Function Check .....                                      | 950        | Calculated Load Value .....                                 | 982        |
| Diagnosis Procedure .....   | 950        | Mass Air Flow Sensor .....                                  | 982        |
| Component Inspection (ICC Brake Switch) .....                       | 951        | <b>VK56VD FOR USA AND CANADA</b>                            |            |
| <b>IGNITION SIGNAL .....</b>  | <b>952</b> | <b>PRECAUTION .....</b>                                     | <b>983</b> |
| Component Function Check .....                                      | 952        | <b>PRECAUTIONS .....</b>                                    | <b>983</b> |
| Diagnosis Procedure .....   | 952        |   |            |
| Component Inspection (Ignition Coil with Power<br>Transistor) ..... | 955        |   |            |
| Component Inspection (Condenser) .....                              | 956        |   |            |
| <b>MALFUNCTION INDICATOR LAMP .....</b>                             | <b>957</b> |   |            |
| Component Function Check .....                                      | 957        |   |            |
| Diagnosis Procedure .....   | 957        |   |            |
| <b>MAP (MANIFOLD ABSOLUTE PRESSURE)<br/>SENSOR .....</b>            | <b>958</b> |   |            |

|  |            |   |             |    |
|--|------------|---|-------------|----|
| Precaution for Supplemental Restraint System (SRS) "AIR BAG" and "SEAT BELT PRE-TENSIONER" ..... | 983        | Intake Valve Timing Control Solenoid Valve .....                | 1005        | A  |
| Precaution for Procedure without Cowl Top Cover .....  | 983        | Knock Sensor .....  | 1005        |    |
| Precautions For Xenon Headlamp Service .....   | 983        | Low Fuel Pressure Sensor .....                                  | 1006        |    |
| On Board Diagnostic (OBD) System of Engine and A/T .....   | 984        | Low Pressure Fuel Pump .....                                    | 1006        |    |
| General Precautions .....  | 984        | Malfunction Indicator Lamp (MIL) .....                          | 1006        | EC |
| <b>PREPARATION .....</b>   | <b>988</b> | Manifold Absolute Pressure Sensor .....                         | 1006        |    |
| <b>PREPARATION .....</b>   | <b>988</b> | Mass Air Flow Sensor (With Intake Air Temperature Sensor) ..... | 1006        | C  |
| Special Service Tools .....  | 988        | Power Steering Pressure (PSP) Sensor .....                      | 1007        |    |
| Commercial Service Tools .....   | 988        | Refrigerant Pressure Sensor .....                               | 1007        |    |
| <b>SYSTEM DESCRIPTION .....</b>  | <b>990</b> | Stop Lamp Switch .....  | 1007        | D  |
| <b>COMPONENT PARTS .....</b>   | <b>990</b> | VVEL Actuator Motor .....                                       | 1008        |    |
| <b>ENGINE CONTROL SYSTEM .....</b>   | <b>990</b> | VVEL Actuator Motor Relay .....                                 | 1008        |    |
| ENGINE CONTROL SYSTEM : Component Parts Location .....   | 990        | VVEL Control Module .....                                       | 1008        | E  |
| ENGINE CONTROL SYSTEM : Component Description .....  | 993        | VVEL Control Shaft Position Sensor .....                        | 1008        |    |
| <b>INFINITI DRIVE MODE SELECTOR .....</b>  | <b>994</b> | <b>STRUCTURE AND OPERATION .....</b>                            | <b>1009</b> |    |
| Infiniti Drive Mode Selector : Component Parts Location .....                                    | 995        | Positive Crankcase Ventilation .....                            | 1009        | F  |
| Infiniti Drive Mode Selector : Component Description .....                                       | 995        | On Board Refueling Vapor Recovery (ORVR) .....                  | 1010        |    |
| Accelerator Pedal Position Sensor .....  | 996        | <b>SYSTEM .....</b>   | <b>1011</b> |    |
| Air Fuel Ratio (A/F) Sensor 1 .....  | 996        | <b>ENGINE CONTROL SYSTEM .....</b>                              | <b>1011</b> | G  |
| ASCD Brake Switch .....  | 996        | ENGINE CONTROL SYSTEM : System Diagram .....                    | 1011        |    |
| ASCD Steering Switch .....   | 996        | ENGINE CONTROL SYSTEM : System Description .....                | 1011        | H  |
| Battery Current Sensor (With Battery Temperature Sensor) .....                                   | 997        | <b>DIRECT INJECTION GASOLINE SYSTEM .....</b>                   | <b>1012</b> |    |
| Camshaft Position Sensor .....   | 997        | DIRECT INJECTION GASOLINE SYSTEM : System Diagram .....         | 1012        | I  |
| Cooling Fan .....  | 998        | DIRECT INJECTION GASOLINE SYSTEM : System Description .....     | 1012        | J  |
| Crankshaft Position Sensor .....   | 998        | <b>FUEL PRESSURE CONTROL .....</b>                              | <b>1015</b> |    |
| ECM .....  | 999        | FUEL PRESSURE CONTROL : System Diagram .....                    | 1015        | K  |
| Electric Throttle Control Actuator .....   | 999        | FUEL PRESSURE CONTROL : System Description .....                | 1015        |    |
| Engine Coolant Temperature Sensor .....  | 1000       | <b>COOLING FAN CONTROL .....</b>                                | <b>1016</b> | L  |
| Engine Oil Pressure Sensor .....   | 1000       | COOLING FAN CONTROL : System Diagram .....                      | 1017        |    |
| Engine Oil Temperature Sensor .....  | 1000       | COOLING FAN CONTROL : System Description .....                  | 1017        |    |
| EVAP Control System Pressure Sensor .....  | 1001       | <b>ELECTRIC IGNITION SYSTEM .....</b>                           | <b>1017</b> | M  |
| EVAP Canister Vent Control Valve .....   | 1001       | ELECTRIC IGNITION SYSTEM : System Diagram .....                 | 1018        |    |
| EVAP Canister Purge Volume Control Solenoid Valve .....  | 1001       | ELECTRIC IGNITION SYSTEM : System Description .....             | 1018        | N  |
| Exhaust Valve Timing Control Position Sensor .....   | 1002       | <b>INTAKE VALVE TIMING CONTROL .....</b>                        | <b>1019</b> |    |
| Exhaust Valve Timing Control Solenoid Valve .....  | 1002       | INTAKE VALVE TIMING CONTROL : System Diagram .....              | 1019        | O  |
| Fuel Injector .....  | 1002       | INTAKE VALVE TIMING CONTROL : System Description .....          | 1019        | P  |
| Fuel Tank Temperature Sensor .....   | 1002       | <b>EXHAUST VALVE TIMING CONTROL .....</b>                       | <b>1019</b> |    |
| Heated Oxygen Sensor 2 .....   | 1003       | EXHAUST VALVE TIMING CONTROL : System Diagram .....             | 1020        |    |
| High Pressure Fuel Pump .....  | 1003       | EXHAUST VALVE TIMING CONTROL : System Description .....         | 1020        |    |
| Fuel Pump Control Module .....   | 1004       | <b>VVEL SYSTEM .....</b>  | <b>1020</b> |    |
| Fuel Rail Pressure Sensor .....  | 1004       |   |             |    |
| ICC Brake Switch .....   | 1004       |   |             |    |
| ICC Steering Switch .....  | 1004       |   |             |    |
| Ignition Coil With Power Transistor .....  | 1005       |   |             |    |
| Information Display .....  | 1005       |   |             |    |

|  |             |   |             |
|--|-------------|---|-------------|
| VVEL SYSTEM : System Diagram .....   | 1021        | DIAGNOSIS DESCRIPTION : Permanent Diagnostic Trouble Code (Permanent DTC) ..... | 1040        |
| VVEL SYSTEM : System Description .....   | 1021        | DIAGNOSIS DESCRIPTION : Malfunction Indicator Lamp (MIL) .....                  | 1041        |
| <b>EVAPORATIVE EMISSION SYSTEM .....</b>   | <b>1022</b> | On Board Diagnosis Function .....   | 1041        |
| EVAPORATIVE EMISSION SYSTEM : System Diagram .....                                     | 1022        | CONSULT Function .....  | 1044        |
| EVAPORATIVE EMISSION SYSTEM : System Description .....                                 | 1022        | <b>ECU DIAGNOSIS INFORMATION .....</b>  | <b>1055</b> |
| <b>AIR CONDITIONING CUT CONTROL .....</b>  | <b>1023</b> | <b>ECM .....</b>  | <b>1055</b> |
| AIR CONDITIONING CUT CONTROL : System Diagram .....                                    | 1023        | Reference Value .....   | 1055        |
| AIR CONDITIONING CUT CONTROL : System Description .....                                | 1023        | Fail-safe .....   | 1078        |
| <b>ALTERNATOR POWER GENERATION VOLTAGE VARIABLE CONTROL SYSTEM .....</b>               | <b>1024</b> | DTC Inspection Priority Chart .....   | 1081        |
| ALTERNATOR POWER GENERATION VOLTAGE VARIABLE CONTROL SYSTEM : System Description ..... | 1024        | DTC Index .....   | 1083        |
| <b>AUTOMATIC SPEED CONTROL DEVICE (ASCD) .....</b>                                     | <b>1024</b> | Test Value and Test Limit .....   | 1089        |
| AUTOMATIC SPEED CONTROL DEVICE (ASCD) : System Diagram .....                           | 1025        | <b>VVEL CONTROL MODULE .....</b>  | <b>1096</b> |
| AUTOMATIC SPEED CONTROL DEVICE (ASCD) : System Description .....                       | 1025        | Reference Value .....   | 1096        |
| <b>CAN COMMUNICATION .....</b>   | <b>1025</b> | <b>WIRING DIAGRAM .....</b>   | <b>1100</b> |
| CAN COMMUNICATION : System Description ..  | 1025        | <b>ENGINE CONTROL SYSTEM .....</b>  | <b>1100</b> |
| <b>FUEL FILLER CAP WARNING SYSTEM .....</b>  | <b>1025</b> | Wiring Diagram .....  | 1100        |
| FUEL FILLER CAP WARNING SYSTEM : System Diagram .....                                  | 1026        | <b>BASIC INSPECTION .....</b>   | <b>1108</b> |
| FUEL FILLER CAP WARNING SYSTEM : System Description .....                              | 1026        | <b>DIAGNOSIS AND REPAIR WORKFLOW .....</b>                                      | <b>1108</b> |
| <b>INFINITI DRIVE MODE SELECTOR .....</b>  | <b>1027</b> | Work Flow .....   | 1108        |
| Infiniti Drive Mode Selector : System Description ..                                   | 1027        | Diagnostic Work Sheet .....   | 1111        |
| <b>OPERATION .....</b>   | <b>1030</b> | <b>BASIC INSPECTION .....</b>   | <b>1113</b> |
| <b>AUTOMATIC SPEED CONTROL DEVICE (ASCD) .....</b>                                     | <b>1030</b> | Work Procedure .....  | 1113        |
| AUTOMATIC SPEED CONTROL DEVICE (ASCD) : Switch Name and Function .....                 | 1030        | <b>ADDITIONAL SERVICE WHEN REPLACING ECM .....</b>                              | <b>1117</b> |
| <b>HANDLING PRECAUTION .....</b>   | <b>1032</b> | Description .....   | 1117        |
| Infiniti Drive Mode Selector .....   | 1032        | Work Procedure .....  | 1117        |
| <b>ON BOARD DIAGNOSTIC (OBD) SYSTEM .....</b>  | <b>1033</b> | <b>ADDITIONAL SERVICE WHEN REPLACING VVEL CONTROL MODULE .....</b>              | <b>1118</b> |
| Diagnosis Description .....  | 1033        | Description .....   | 1118        |
| GST (Generic Scan Tool) .....  | 1033        | Work Procedure .....  | 1118        |
| <b>DIAGNOSIS SYSTEM (ECM) .....</b>  | <b>1034</b> | <b>VIN REGISTRATION .....</b>   | <b>1119</b> |
| <b>DIAGNOSIS DESCRIPTION .....</b>   | <b>1034</b> | Description .....   | 1119        |
| DIAGNOSIS DESCRIPTION : 1st Trip Detection Logic and Two Trip Detection Logic .....    | 1034        | Work Procedure .....  | 1119        |
| DIAGNOSIS DESCRIPTION : DTC and Freeze Frame Data .....                                | 1034        | <b>ACCELERATOR PEDAL RELEASED POSITION LEARNING .....</b>                       | <b>1120</b> |
| DIAGNOSIS DESCRIPTION : Counter System ..  | 1035        | Description .....   | 1120        |
| DIAGNOSIS DESCRIPTION : Driving Pattern ..   | 1038        | Work Procedure .....  | 1120        |
| DIAGNOSIS DESCRIPTION : System Readiness Test (SRT) Code .....                         | 1039        | <b>THROTTLE VALVE CLOSED POSITION LEARNING .....</b>                            | <b>1121</b> |
|  |             | Description .....   | 1121        |
|  |             | Work Procedure .....  | 1121        |
|  |             | <b>IDLE AIR VOLUME LEARNING .....</b>   | <b>1122</b> |
|  |             | Description .....   | 1122        |
|  |             | Work Procedure .....  | 1122        |



|   |      |   |      |    |
|---|------|---|------|----|
| <b>VVEL CONTROL SHAFT POSITION SENSOR ADJUSTMENT</b> .....              | 1124 | DTC Logic .....   | 1169 | A  |
| Description .....   | 1124 | Diagnosis Procedure .....   | 1170 |    |
| Work Procedure .....  | 1124 | Component Inspection (Echast Valve Timing Control Solenoid Valve) ..... | 1171 |    |
| <b>MIXTURE RATIO SELF-LEARNING VALUE CLEAR</b> .....                    | 1126 | <b>P0031, P0032, P0051, P0052 A/F SENSOR 1 HEATER</b> .....             | 1173 | EC |
| Description .....   | 1126 | DTC Logic .....   | 1173 |    |
| Work Procedure .....  | 1126 | Diagnosis Procedure .....   | 1173 | C  |
| <b>FUEL PRESSURE</b> .....  | 1127 | Component Inspection (A/F Sensor 1 Heater) .....                        | 1174 |    |
| Work Procedure .....  | 1127 | <b>P0037, P0038, P0057, P0058 HO2S2 HEATER</b> .....                    | 1176 | D  |
| <b>HOW TO SET SRT CODE</b> .....  | 1130 | DTC Logic .....   | 1176 |    |
| Description .....   | 1130 | Diagnosis Procedure .....   | 1176 | E  |
| SRT Set Driving Pattern .....   | 1131 | Component Inspection (HO2 Sensor 2 Heater) .....                        | 1178 |    |
| Work Procedure .....  | 1133 | <b>P0075, P0081 IVT CONTROL SOLENOID VALVE</b> .....                    | 1179 | F  |
| <b>HOW TO ERASE PERMANENT DTC</b> .....                                 | 1136 | DTC Logic .....   | 1179 |    |
| Description .....   | 1136 | Diagnosis Procedure .....   | 1179 | G  |
| Work Procedure (Group A) .....  | 1137 | Component Inspection (Intake Valve Timing Control Solenoid Valve) ..... | 1180 |    |
| Work Procedure (Group B) .....  | 1139 | <b>P0078, P0084 EVT CONTROL SOLENOID VALVE</b> .....                    | 1182 | H  |
| <b>DTC/CIRCUIT DIAGNOSIS</b> .....                                      | 1142 | DTC Logic .....   | 1182 |    |
| <b>TROUBLE DIAGNOSIS - SPECIFICATION VALUE</b> .....                    | 1142 | Diagnosis Procedure .....   | 1182 | I  |
| Description .....   | 1142 | Component Inspection (Echast Valve Timing Control Solenoid Valve) ..... | 1183 |    |
| Component Function Check .....  | 1142 | <b>P008A LOW FUEL PRESSURE CONTROL SYSTEM</b> .....                     | 1185 | J  |
| Diagnosis Procedure .....   | 1143 | DTC Logic .....   | 1185 |    |
| <b>POWER SUPPLY AND GROUND CIRCUIT</b> .....                            | 1149 | Diagnosis Procedure .....   | 1185 | K  |
| Diagnosis Procedure .....   | 1149 | <b>P008B LOW FUEL PRESSURE CONTROL SYSTEM</b> .....                     | 1187 |    |
| <b>U0101 CAN COMM CIRCUIT</b> .....                                     | 1153 | DTC Logic .....   | 1187 | L  |
| DTC Logic .....   | 1153 | Diagnosis Procedure .....   | 1187 |    |
| Diagnosis Procedure .....   | 1153 | <b>P0087 FRP CONTROL SYSTEM</b> .....                                   | 1188 | M  |
| <b>U0113, U1003 CAN COMM CIRCUIT</b> .....                              | 1154 | DTC Logic .....   | 1188 |    |
| DTC Logic .....   | 1154 | Diagnosis Procedure .....   | 1189 | N  |
| Diagnosis Procedure .....   | 1154 | Component Inspection (High Pressure Fuel Pump) .....                    | 1191 |    |
| <b>U1001 CAN COMM CIRCUIT</b> .....                                     | 1156 | <b>P0088 FRP CONTROL SYSTEM</b> .....                                   | 1192 | O  |
| DTC Logic .....   | 1156 | DTC Logic .....   | 1192 |    |
| Diagnosis Procedure .....   | 1156 | Diagnosis Procedure .....   | 1192 |    |
| <b>U1024 CAN COMM CIRCUIT</b> .....                                     | 1157 | Component Inspection (High Pressure Fuel Pump) .....                    | 1193 | P  |
| DTC Logic .....   | 1157 | <b>P0090 HIGH PRESSURE FUEL PUMP</b> .....                              | 1195 |    |
| Diagnosis Procedure .....   | 1157 | DTC Logic .....   | 1195 |    |
| <b>P006A, P0101, P010B MAF SENSOR</b> .....                             | 1159 | Diagnosis Procedure .....   | 1195 |    |
| DTC Logic .....   | 1159 | Component Inspection (High Pressure Fuel Pump) .....                    | 1196 |    |
| Diagnosis Procedure .....   | 1160 | <b>P0102, P0103, P010C, P010D MAF SENSOR</b> .....                      | 1198 |    |
| Component Inspection (MAF Sensor) .....                                 | 1162 | DTC Logic .....   | 1198 |    |
| <b>P0011, P0021 IVT CONTROL</b> .....                                   | 1165 |   |      |    |
| DTC Logic .....   | 1165 |   |      |    |
| Diagnosis Procedure .....   | 1166 |   |      |    |
| Component Inspection (Intake Valve Timing Control Solenoid Valve) ..... | 1167 |   |      |    |
| <b>P0014, P0024 EVT CONTROL</b> .....                                   | 1169 |   |      |    |

|  |             |  |             |
|--|-------------|--|-------------|
| Diagnosis Procedure .....                                      | 1199        | Component Inspection (Engine Coolant Temperature Sensor) ..... | 1228        |
| Component Inspection (MAF Sensor) .....                        | 1200        |  |             |
| <b>P0106 MANIFOLD ABSOLUTE PRESSURE SENSOR .....</b>           | <b>1204</b> | <b>P0130, P0150 A/F SENSOR 1 .....</b>                         | <b>1229</b> |
| DTC Logic .....  | 1204        | DTC Logic .....  | 1229        |
| Diagnosis Procedure .....                                      | 1205        | Component Function Check .....                                 | 1230        |
| Component Inspection (MAP Sensor) .....                        | 1206        | Diagnosis Procedure .....                                      | 1231        |
| <b>P010A MANIFOLD ABSOLUTE PRESSURE SENSOR .....</b>           | <b>1208</b> | <b>P0131, P0151 A/F SENSOR 1 .....</b>                         | <b>1233</b> |
| DTC Logic .....  | 1208        | DTC Logic .....  | 1233        |
| Diagnosis Procedure .....                                      | 1208        | Diagnosis Procedure .....                                      | 1234        |
| Component Inspection (MAP Sensor) .....                        | 1209        | <b>P0132, P0152 A/F SENSOR 1 .....</b>                         | <b>1236</b> |
| <b>P0111 IAT SENSOR .....</b>                                  | <b>1211</b> | DTC Logic .....  | 1236        |
| DTC Logic .....  | 1211        | Diagnosis Procedure .....                                      | 1237        |
| Component Function Check .....                                 | 1212        | <b>P0133, P0153 A/F SENSOR 1 .....</b>                         | <b>1239</b> |
| Diagnosis Procedure .....                                      | 1212        | DTC Logic .....  | 1239        |
| Component Inspection .....                                     | 1212        | Diagnosis Procedure .....                                      | 1240        |
| <b>P0112, P0113 IAT SENSOR .....</b>                           | <b>1213</b> | <b>P0137, P0157 HO2S2 .....</b>                                | <b>1244</b> |
| DTC Logic .....  | 1213        | DTC Logic .....  | 1244        |
| Diagnosis Procedure .....                                      | 1213        | Component Function Check .....                                 | 1245        |
| Component Inspection (Intake Air Temperature Sensor) .....     | 1214        | Diagnosis Procedure .....                                      | 1246        |
| <b>P0116 ECT SENSOR .....</b>                                  | <b>1215</b> | Component Inspection (HO2 sensor 2) .....                      | 1247        |
| DTC Logic .....  | 1215        | <b>P0138, P0158 HO2S2 .....</b>                                | <b>1250</b> |
| Component Function Check .....                                 | 1216        | DTC Logic .....  | 1250        |
| Diagnosis Procedure .....                                      | 1216        | Component Function Check .....                                 | 1252        |
| Component Inspection (Engine Coolant Temperature Sensor) ..... | 1216        | Diagnosis Procedure .....                                      | 1253        |
| <b>P0117, P0118 ECT SENSOR .....</b>                           | <b>1218</b> | Component Inspection (HO2 sensor 2) .....                      | 1255        |
| DTC Logic .....  | 1218        | <b>P0139, P0159 HO2S2 .....</b>                                | <b>1258</b> |
| Diagnosis Procedure .....                                      | 1218        | DTC Logic .....  | 1258        |
| Component Inspection (Engine Coolant Temperature Sensor) ..... | 1219        | Component Function Check .....                                 | 1259        |
| <b>P0122, P0123, P0227, P0228 TP SENSOR .....</b>              | <b>1220</b> | Diagnosis Procedure .....                                      | 1260        |
| DTC Logic .....  | 1220        | Component Inspection (HO2 sensor 2) .....                      | 1261        |
| Diagnosis Procedure .....                                      | 1220        | <b>P0171, P0174 FUEL INJECTION SYSTEM FUNCTION .....</b>       | <b>1264</b> |
| Component Inspection (Throttle Position Sensor) .....          | 1221        | DTC Logic .....  | 1264        |
| <b>P0125 ECT SENSOR .....</b>                                  | <b>1223</b> | Diagnosis Procedure .....                                      | 1265        |
| DTC Logic .....  | 1223        | <b>P0172, P0175 FUEL INJECTION SYSTEM FUNCTION .....</b>       | <b>1268</b> |
| Diagnosis Procedure .....                                      | 1223        | DTC Logic .....  | 1268        |
| Component Inspection (Engine Coolant Temperature Sensor) ..... | 1224        | Diagnosis Procedure .....                                      | 1269        |
| <b>P0127 IAT SENSOR .....</b>                                  | <b>1225</b> | <b>P0181 FTT SENSOR .....</b>                                  | <b>1272</b> |
| DTC Logic .....  | 1225        | DTC Logic .....  | 1272        |
| Diagnosis Procedure .....                                      | 1225        | Component Function Check .....                                 | 1273        |
| Component Inspection (Intake Air Temperature Sensor) .....     | 1226        | Diagnosis Procedure .....                                      | 1274        |
| <b>P0128 THERMOSTAT FUNCTION .....</b>                         | <b>1227</b> | Component Inspection (Fuel Tank Temperature Sensor) .....      | 1275        |
| DTC Logic .....  | 1227        | <b>P0182, P0183 FTT SENSOR .....</b>                           | <b>1276</b> |
| Diagnosis Procedure .....                                      | 1228        | DTC Logic .....  | 1276        |
|  |             | Diagnosis Procedure .....                                      | 1276        |
|  |             | Component Inspection (Fuel Tank Temperature Sensor) .....      | 1277        |
|  |             | <b>P0190, P0192, P0193 FRP SENSOR .....</b>                    | <b>1279</b> |

|  |             |  |             |           |
|--|-------------|--|-------------|-----------|
| DTC Logic .....  | 1279        | <b>P0441 EVAP CONTROL SYSTEM .....</b>   | <b>1319</b> |           |
| Diagnosis Procedure .....  | 1279        | DTC Logic .....  | 1319        | A         |
| Component Inspection (Fuel Rail Pressure Sensor) .....                             | 1281        | Component Function Check .....   | 1320        |           |
|  |             | Diagnosis Procedure .....  | 1321        |           |
| <b>P0191 FRP SENSOR .....</b>  | <b>1283</b> | <b>P0443 EVAP CANISTER PURGE VOLUME CONTROL SOLENOID VALVE .....</b>           | <b>1324</b> | <b>EC</b> |
| DTC Logic .....  | 1283        | DTC Logic .....  | 1324        |           |
| Diagnosis Procedure .....  | 1283        | Diagnosis Procedure .....  | 1325        | C         |
| Component Inspection (Fuel Rail Pressure Sensor) .....                             | 1285        | Component Inspection (EVAP Canister Purge Volume Control Solenoid Valve) ..... | 1327        |           |
| <b>P0196 EOT SENSOR .....</b>  | <b>1287</b> | <b>P0444, P0445 EVAP CANISTER PURGE VOLUME CONTROL SOLENOID VALVE .....</b>    | <b>1329</b> | D         |
| DTC Logic .....  | 1287        | DTC Logic .....  | 1329        |           |
| Component Function Check .....   | 1289        | Diagnosis Procedure .....  | 1329        | E         |
| Diagnosis Procedure .....  | 1289        | Component Inspection (EVAP Canister Purge Volume Control Solenoid Valve) ..... | 1330        |           |
| Component Inspection (Engine Oil Temperature Sensor) .....                         | 1289        | <b>P0447 EVAP CANISTER VENT CONTROL VALVE .....</b>                            | <b>1332</b> | F         |
| <b>P0197, P0198 EOT SENSOR .....</b>   | <b>1291</b> | DTC Logic .....  | 1332        |           |
| DTC Logic .....  | 1291        | Diagnosis Procedure .....  | 1332        | G         |
| Diagnosis Procedure .....  | 1291        | Component Inspection (EVAP Canister Vent Control Valve) .....                  | 1334        |           |
| Component Inspection (Engine Oil Temperature Sensor) .....                         | 1292        | <b>P0448 EVAP CANISTER VENT CONTROL VALVE .....</b>                            | <b>1336</b> | H         |
| <b>P0201, P0202, P0203, P0204, P0205, P0206, P0207, P0208 INJECTOR .....</b>       | <b>1293</b> | DTC Logic .....  | 1336        | I         |
| DTC Logic .....  | 1293        | Diagnosis Procedure .....  | 1336        |           |
| Diagnosis Procedure .....  | 1293        | Component Inspection (EVAP Canister Vent Control Valve) .....                  | 1338        | J         |
| <b>P0222, P0223, P2132, P2133 TP SENSOR .....</b>                                  | <b>1294</b> | <b>P0451 EVAP CONTROL SYSTEM PRES-SURE SENSOR .....</b>                        | <b>1340</b> | K         |
| DTC Logic .....  | 1294        | DTC Logic .....  | 1340        |           |
| Diagnosis Procedure .....  | 1294        | Diagnosis Procedure .....  | 1341        |           |
| Component Inspection (Throttle Position Sensor) .....                              | 1295        | Component Inspection (EVAP Control System Pressure Sensor) .....               | 1343        | L         |
| <b>P0300, P0301, P0302, P0303, P0304, P0305, P0306, P0307, P0308 MISFIRE .....</b> | <b>1297</b> | <b>P0452 EVAP CONTROL SYSTEM PRES-SURE SENSOR .....</b>                        | <b>1344</b> | M         |
| DTC Logic .....  | 1297        | DTC Logic .....  | 1344        |           |
| Diagnosis Procedure .....  | 1298        | Diagnosis Procedure .....  | 1345        |           |
| <b>P0327, P0328, P0332, P0333 KS .....</b>   | <b>1303</b> | Component Inspection (EVAP Control System Pressure Sensor) .....               | 1347        | N         |
| DTC Logic .....  | 1303        | <b>P0453 EVAP CONTROL SYSTEM PRES-SURE SENSOR .....</b>                        | <b>1349</b> | O         |
| Diagnosis Procedure .....  | 1303        | DTC Logic .....  | 1349        |           |
| Component Inspection (Knock Sensor) .....  | 1304        | Diagnosis Procedure .....  | 1350        |           |
| <b>P0335 CKP SENSOR .....</b>  | <b>1305</b> | Component Inspection (EVAP Control System Pressure Sensor) .....               | 1353        | P         |
| DTC Logic .....  | 1305        | <b>P0456 EVAP CONTROL SYSTEM .....</b>   | <b>1355</b> |           |
| Diagnosis Procedure .....  | 1305        | DTC Logic .....  | 1355        |           |
| Component Inspection (Crankshaft Position Sensor) .....                            | 1307        | Diagnosis Procedure .....  | 1356        |           |
| <b>P0340, P0345 CMP SENSOR .....</b>   | <b>1309</b> | Component Inspection (Fuel Filler Cap) .....                                   | 1360        |           |
| DTC Logic .....  | 1309        | <b>P0460 FUEL LEVEL SENSOR .....</b>   | <b>1361</b> |           |
| Diagnosis Procedure .....  | 1310        |  |             |           |
| Component Inspection (Camshaft Position Sensor) .....                              | 1312        |  |             |           |
| <b>P0420, P0430 THREE WAY CATALYST FUNCTION .....</b>                              | <b>1314</b> |  |             |           |
| DTC Logic .....  | 1314        |  |             |           |
| Component Function Check .....   | 1315        |  |             |           |
| Diagnosis Procedure .....  | 1316        |  |             |           |

|  |             |  |             |
|--|-------------|--|-------------|
| DTC Logic .....  | 1361        | DTC Logic .....  | 1387        |
| Diagnosis Procedure .....                                      | 1361        | Diagnosis Procedure .....  | 1387        |
| <b>P0461 FUEL LEVEL SENSOR .....</b>                           | <b>1362</b> | <b>P062B ECM .....</b>   | <b>1388</b> |
| DTC Logic .....  | 1362        | Description .....  | 1388        |
| Component Function Check .....                                 | 1362        | DTC Logic .....  | 1388        |
| Diagnosis Procedure .....                                      | 1363        | Diagnosis Procedure .....  | 1388        |
| <b>P0462, P0463 FUEL LEVEL SENSOR .....</b>                    | <b>1364</b> | <b>P0643 SENSOR POWER SUPPLY .....</b>                                       | <b>1389</b> |
| DTC Logic .....  | 1364        | DTC Logic .....  | 1389        |
| Diagnosis Procedure .....                                      | 1364        | Diagnosis Procedure .....  | 1389        |
| <b>P0500 VSS .....</b>   | <b>1365</b> | <b>P0850 PNP SWITCH .....</b>  | <b>1391</b> |
| Description .....  | 1365        | Description .....  | 1391        |
| DTC Logic .....  | 1365        | DTC Logic .....  | 1391        |
| Diagnosis Procedure .....                                      | 1365        | Component Function Check .....   | 1392        |
| <b>P0506 ISC SYSTEM .....</b>                                  | <b>1367</b> | Diagnosis Procedure .....  | 1392        |
| Description .....  | 1367        | <b>P100A, P100B VVEL SYSTEM .....</b>  | <b>1394</b> |
| DTC Logic .....  | 1367        | DTC Logic .....  | 1394        |
| Diagnosis Procedure .....                                      | 1367        | Diagnosis Procedure .....  | 1394        |
| <b>P0507 ISC SYSTEM .....</b>                                  | <b>1369</b> | Component Inspection (VVEL ACTUATOR MO-<br>TOR) .....                        | 1396        |
| Description .....  | 1369        | Component Inspection (VVEL ACTUATOR SUB<br>ASSEMBLY) .....                   | 1396        |
| DTC Logic .....  | 1369        | <b>P1078, P1084 EVT CONTROL POSITION<br/>SENSOR .....</b>                    | <b>1398</b> |
| Diagnosis Procedure .....                                      | 1369        | DTC Logic .....  | 1398        |
| <b>P050A, P050B, P050E COLD START CON-<br/>TROL .....</b>      | <b>1371</b> | Diagnosis Procedure .....  | 1398        |
| Description .....  | 1371        | Component Inspection (Exhaust Valve Timing<br>Control Position Sensor) ..... | 1400        |
| DTC Logic .....  | 1371        | <b>P1087, P1088 VVEL SYSTEM .....</b>  | <b>1401</b> |
| Diagnosis Procedure .....                                      | 1372        | DTC Logic .....  | 1401        |
| <b>P0520 EOP SENSOR .....</b>                                  | <b>1373</b> | Diagnosis Procedure .....  | 1401        |
| DTC Logic .....  | 1373        | <b>P1089, P1092 VVEL CONTROL SHAFT PO-<br/>SITION SENSOR .....</b>           | <b>1402</b> |
| Diagnosis Procedure .....                                      | 1373        | DTC Logic .....  | 1402        |
| Component Inspection (EOP sensor) .....                        | 1375        | Diagnosis Procedure .....  | 1402        |
| <b>P0524 ENGINE OIL PRESSURE .....</b>                         | <b>1376</b> | <b>P1090, P1093 VVEL ACTUATOR MOTOR ...</b>                                  | <b>1405</b> |
| DTC Logic .....  | 1376        | DTC Logic .....  | 1405        |
| Diagnosis Procedure .....                                      | 1377        | Diagnosis Procedure .....  | 1405        |
| <b>P0550 PSP SENSOR .....</b>                                  | <b>1379</b> | Component Inspection (VVEL ACTUATOR MO-<br>TOR) .....                        | 1407        |
| DTC Logic .....  | 1379        | Component Inspection (VVEL ACTUATOR SUB<br>ASSEMBLY) .....                   | 1407        |
| Diagnosis Procedure .....                                      | 1379        | <b>P1091 VVEL ACTUATOR MOTOR RELAY ...</b>                                   | <b>1408</b> |
| Component Inspection (Power Steering Pressure<br>Sensor) ..... | 1381        | DTC Logic .....  | 1408        |
| <b>P0603 ECM POWER SUPPLY .....</b>                            | <b>1382</b> | Diagnosis Procedure .....  | 1408        |
| DTC Logic .....  | 1382        | Component Inspection (VVEL Actuator Motor Re-<br>lay) .....                  | 1410        |
| Diagnosis Procedure .....                                      | 1382        | <b>P1148, P1168 CLOSED LOOP CONTROL ...</b>                                  | <b>1411</b> |
| <b>P0605 ECM .....</b>   | <b>1384</b> | DTC Logic .....  | 1411        |
| DTC Logic .....  | 1384        | Diagnosis Procedure .....  | 1411        |
| Diagnosis Procedure .....                                      | 1384        | <b>P1197 OUT OF GAS .....</b>  | <b>1412</b> |
| <b>P0607 ECM .....</b>   | <b>1386</b> |  |             |
| DTC Logic .....  | 1386        |  |             |
| Diagnosis Procedure .....                                      | 1386        |  |             |
| <b>P0611 ECM PROTECTION .....</b>                              | <b>1387</b> |  |             |
| Description .....  | 1387        |  |             |

|   |             |   |             |
|---|-------------|---|-------------|
| Description .....                                     | 1412        | <b>P1551, P1552 BATTERY CURRENT SEN-</b>            |             |
| DTC Logic .....                                       | 1412        | <b>SOR .....</b>                                    | <b>1440</b> |
| Diagnosis Procedure .....                             | 1413        | DTC Logic .....                                     | 1440        |
| <b>P1212 TCS COMMUNICATION LINE .....</b>             | <b>1414</b> | Diagnosis Procedure .....                           | 1440        |
| Description .....                                     | 1414        | Component Inspection (Battery Current Sensor) ..... | 1442        |
| DTC Logic .....                                       | 1414        | <b>P1553 BATTERY CURRENT SENSOR .....</b>           | <b>1444</b> |
| Diagnosis Procedure .....                             | 1414        | DTC Logic .....                                     | 1444        |
| <b>P1217 ENGINE OVER TEMPERATURE .....</b>            | <b>1415</b> | Diagnosis Procedure .....                           | 1444        |
| DTC Logic .....                                       | 1415        | Component Inspection (Battery Current Sensor) ..... | 1446        |
| Component Function Check .....                        | 1415        | <b>P1554 BATTERY CURRENT SENSOR .....</b>           | <b>1448</b> |
| Diagnosis Procedure .....                             | 1416        | DTC Logic .....                                     | 1448        |
| <b>P1220 FUEL PUMP CONTROL MODULE</b>                 |             | Component Function Check .....                      | 1448        |
| <b>(FPCM) .....</b>                                   | <b>1418</b> | Diagnosis Procedure .....                           | 1449        |
| DTC Logic .....                                       | 1418        | Component Inspection (Battery Current Sensor) ..... | 1451        |
| Diagnosis Procedure .....                             | 1418        | <b>P1556, P1557 BATTERY TEMPERATURE</b>             |             |
| Component Inspection (FPCM) .....                     | 1420        | <b>SENSOR .....</b>                                 | <b>1452</b> |
| <b>P1225, P1234 TP SENSOR .....</b>                   | <b>1421</b> | DTC Logic .....                                     | 1452        |
| DTC Logic .....                                       | 1421        | Diagnosis Procedure .....                           | 1452        |
| Diagnosis Procedure .....                             | 1421        | Component Inspection (Battery Temperature           |             |
| <b>P1226, P1235 TP SENSOR .....</b>                   | <b>1422</b> | Sensor) .....                                       | 1454        |
| DTC Logic .....                                       | 1422        | <b>P1564 ASCD STEERING SWITCH .....</b>             | <b>1455</b> |
| Diagnosis Procedure .....                             | 1422        | DTC Logic .....                                     | 1455        |
| <b>P1233, P2101 ELECTRIC THROTTLE CON-</b>            |             | Diagnosis Procedure .....                           | 1455        |
| <b>TROL FUNCTION .....</b>                            | <b>1423</b> | Component Inspection (ASCD Steering Switch) .....   | 1457        |
| DTC Logic .....                                       | 1423        | <b>P1564 ICC STEERING SWITCH .....</b>              | <b>1458</b> |
| Diagnosis Procedure .....                             | 1423        | DTC Logic .....                                     | 1458        |
| Component Inspection (Electric Throttle Control       |             | Diagnosis Procedure .....                           | 1458        |
| Motor) .....  | 1425        | Component Inspection (ICC Steering Switch) .....    | 1460        |
| <b>P1236, P2118 THROTTLE CONTROL MO-</b>              |             | <b>P1568 ICC FUNCTION .....</b>                     | <b>1461</b> |
| <b>TOR .....</b>                                      | <b>1427</b> | DTC Logic .....                                     | 1461        |
| DTC Logic .....                                       | 1427        | Diagnosis Procedure .....                           | 1461        |
| Diagnosis Procedure .....                             | 1427        | <b>P1572 ASCD BRAKE SWITCH .....</b>                | <b>1462</b> |
| Component Inspection (Electric Throttle Control       |             | DTC Logic .....                                     | 1462        |
| Motor) .....  | 1428        | Diagnosis Procedure .....                           | 1463        |
| <b>P1238, P2119 ELECTRIC THROTTLE CON-</b>            |             | Component Inspection (ASCD Brake Switch) .....      | 1466        |
| <b>TROL ACTUATOR .....</b>                            | <b>1429</b> | Component Inspection (Stop Lamp Switch) .....       | 1466        |
| DTC Logic .....                                       | 1429        | <b>P1572 ICC BRAKE SWITCH .....</b>                 | <b>1467</b> |
| Diagnosis Procedure .....                             | 1429        | DTC Logic .....                                     | 1467        |
| <b>P1239, P2135 TP SENSOR .....</b>                   | <b>1431</b> | Diagnosis Procedure .....                           | 1468        |
| DTC Logic .....                                       | 1431        | Component Inspection (ICC Brake Switch) .....       | 1471        |
| Diagnosis Procedure .....                             | 1431        | Component Inspection (Stop Lamp Switch) .....       | 1471        |
| Component Inspection (Throttle Position Sensor) ..... | 1432        | Component Inspection (ICC Brake Hold Relay) .....   | 1472        |
| <b>P1423, P1424 COLD START CONTROL .....</b>          | <b>1434</b> | <b>P1574 ASCD VEHICLE SPEED SENSOR .....</b>        | <b>1473</b> |
| Description .....                                     | 1434        | Description .....                                   | 1473        |
| DTC Logic .....                                       | 1434        | DTC Logic .....                                     | 1473        |
| Diagnosis Procedure .....                             | 1434        | Diagnosis Procedure .....                           | 1473        |
| <b>P1550 BATTERY CURRENT SENSOR .....</b>             | <b>1436</b> | <b>P1574 ICC VEHICLE SPEED SENSOR .....</b>         | <b>1475</b> |
| DTC Logic .....                                       | 1436        | Description .....                                   | 1475        |
| Diagnosis Procedure .....                             | 1436        | DTC Logic .....                                     | 1475        |
| Component Inspection (Battery Current Sensor) .....   | 1438        | Diagnosis Procedure .....                           | 1475        |

|  |             |   |             |
|--|-------------|---|-------------|
| <b>P1606 VVEL CONTROL MODULE</b> .....         | <b>1477</b> | Component Function Check .....                    | 1509        |
| DTC Logic .....                                | 1477        | Diagnosis Procedure .....                         | 1509        |
| Diagnosis Procedure .....                      | 1477        |   |             |
| <b>P1607 VVEL CONTROL MODULE</b> .....         | <b>1478</b> | <b>COOLING FAN</b> .....                          | <b>1510</b> |
| DTC Logic .....                                | 1478        | Description .....                                 | 1510        |
| Diagnosis Procedure .....                      | 1478        | Component Function Check .....                    | 1510        |
|  |             | Diagnosis Procedure .....                         | 1510        |
| <b>P1608 VVEL SENSOR POWER SUPPLY</b> .....    | <b>1479</b> | Component Inspection (Cooling Fan Motor) .....    | 1513        |
| DTC Logic .....                                | 1479        | Component Inspection (Cooling Fan Relay) .....    | 1514        |
| Diagnosis Procedure .....                      | 1479        |   |             |
| <b>P1715 INPUT SPEED SENSOR</b> .....          | <b>1481</b> | <b>ELECTRICAL LOAD SIGNAL</b> .....               | <b>1515</b> |
| Description .....                              | 1481        | Description .....                                 | 1515        |
| DTC Logic .....                                | 1481        | Component Function Check .....                    | 1515        |
| Diagnosis Procedure .....                      | 1481        | Diagnosis Procedure .....                         | 1515        |
| <b>P1805 BRAKE SWITCH</b> .....                | <b>1482</b> | <b>FUEL INJECTOR</b> .....                        | <b>1517</b> |
| DTC Logic .....                                | 1482        | Component Function Check .....                    | 1517        |
| Diagnosis Procedure .....                      | 1482        | Diagnosis Procedure .....                         | 1517        |
| Component Inspection (Stop Lamp Switch) .....  | 1483        | Component Inspection .....                        | 1518        |
| <b>P2100, P2103 THROTTLE CONTROL MO-</b>       |             | <b>HIGH PRESSURE FUEL PUMP</b> .....              | <b>1520</b> |
| <b>TOR RELAY</b> .....                         | <b>1485</b> | Component Function Check .....                    | 1520        |
| DTC Logic .....                                | 1485        | Diagnosis Procedure .....                         | 1520        |
| Diagnosis Procedure .....                      | 1485        | Component Inspection .....                        | 1521        |
| <b>P2122, P2123 APP SENSOR</b> .....           | <b>1487</b> | <b>ICC BRAKE SWITCH</b> .....                     | <b>1522</b> |
| DTC Logic .....                                | 1487        | Component Function Check .....                    | 1522        |
| Diagnosis Procedure .....                      | 1487        | Diagnosis Procedure .....                         | 1522        |
| Component Inspection (Accelerator Pedal Posi-  |             | Component Inspection (ICC Brake Switch) .....     | 1523        |
| tion Sensor) .....                             | 1489        | Component Inspection (ICC Brake Hold Relay) ..... | 1524        |
| <b>P2127, P2128 APP SENSOR</b> .....           | <b>1490</b> | <b>IGNITION SIGNAL</b> .....                      | <b>1525</b> |
| DTC Logic .....                                | 1490        | Component Function Check .....                    | 1525        |
| Diagnosis Procedure .....                      | 1490        | Diagnosis Procedure .....                         | 1525        |
| Component Inspection (Accelerator Pedal Posi-  |             | Component Inspection (Ignition Coil with Power    |             |
| tion Sensor) .....                             | 1493        | Transistor) .....                                 | 1528        |
| <b>P2138 APP SENSOR</b> .....                  | <b>1494</b> | Component Inspection (Condenser) .....            | 1529        |
| DTC Logic .....                                | 1494        | <b>INFORMATION DISPLAY (ASCD)</b> .....           | <b>1530</b> |
| Diagnosis Procedure .....                      | 1494        | Component Function Check .....                    | 1530        |
| Component Inspection (Accelerator Pedal Posi-  |             | Diagnosis Procedure .....                         | 1530        |
| tion Sensor) .....                             | 1497        | <b>LOW PRESSURE FUEL PUMP</b> .....               | <b>1531</b> |
| <b>P2539, P2541, P2542 LOW FUEL PRES-</b>      |             | Component Function Check .....                    | 1531        |
| <b>SURE SENSOR</b> .....                       | <b>1499</b> | Diagnosis Procedure .....                         | 1531        |
| DTC Logic .....                                | 1499        | Component Inspection (Low Pressure Fuel Pump)     |             |
| Diagnosis Procedure .....                      | 1499        | Component Inspection (FPCM) .....                 | 1532        |
| Component Inspection .....                     | 1501        | Component Inspection (FPCM) .....                 | 1533        |
| <b>P2A00, P2A03 A/F SENSOR 1</b> .....         | <b>1503</b> | <b>MALFUNCTION INDICATOR LAMP</b> .....           | <b>1534</b> |
| DTC Logic .....                                | 1503        | Component Function Check .....                    | 1534        |
| Diagnosis Procedure .....                      | 1503        | Diagnosis Procedure .....                         | 1534        |
| <b>ASCD BRAKE SWITCH</b> .....                 | <b>1507</b> | <b>ON BOARD REFUELING VAPOR RECOV-</b>            |             |
| Component Function Check .....                 | 1507        | <b>ERY (ORVR)</b> .....                           | <b>1535</b> |
| Diagnosis Procedure .....                      | 1507        | Component Function Check .....                    | 1535        |
| Component Inspection (ASCD Brake Switch) ..... | 1508        | Diagnosis Procedure .....                         | 1535        |
| <b>ASCD INDICATOR</b> .....                    | <b>1509</b> | Component Inspection (EVAP Vapor Cut Valve) ..... | 1537        |
|  |             | <b>REFRIGERANT PRESSURE SENSOR</b> .....          | <b>1539</b> |
|  |             | Component Function Check .....                    | 1539        |

|   |             |  |             |           |
|---|-------------|--|-------------|-----------|
| Diagnosis Procedure .....                       | 1539        | <b>PREPARATION .....</b>                           | <b>1562</b> |           |
| <b>SYMPTOM DIAGNOSIS .....</b>                  | <b>1541</b> | Special Service Tools .....                        | 1562        | A         |
| <b>ENGINE CONTROL SYSTEM SYMPTOMS .....</b>     | <b>1541</b> | Commercial Service Tools .....                     | 1562        |           |
| Symptom Table .....                             | 1541        | <b>SYSTEM DESCRIPTION .....</b>                    | <b>1564</b> | <b>EC</b> |
| <b>Infiniti Drive Mode Selector .....</b>       | <b>1546</b> | <b>COMPONENT PARTS .....</b>                       | <b>1564</b> |           |
| Symptom Table .....                             | 1546        | <b>ENGINE CONTROL SYSTEM .....</b>                 | <b>1564</b> | C         |
| <b>NORMAL OPERATING CONDITION .....</b>         | <b>1547</b> | ENGINE CONTROL SYSTEM : Component Parts            |             |           |
| Description .....                               | 1547        | Location .....                                     | 1564        |           |
| <b>PERIODIC MAINTENANCE .....</b>               | <b>1548</b> | ENGINE CONTROL SYSTEM : Component De-              |             | D         |
| <b>IDLE SPEED .....</b>                         | <b>1548</b> | scription .....                                    | 1567        |           |
| Inspection .....                                | 1548        | <b>INFINITI DRIVE MODE SELECTOR .....</b>          | <b>1568</b> |           |
| <b>IGNITION TIMING .....</b>                    | <b>1549</b> | Infiniti Drive Mode Selector : Component Parts Lo- |             | E         |
| Inspection .....                                | 1549        | cation .....                                       | 1569        |           |
| <b>EVAP LEAK CHECK .....</b>                    | <b>1550</b> | Infiniti Drive Mode Selector : Component Descrip-  |             | F         |
| Inspection .....                                | 1550        | tion .....   | 1569        |           |
| <b>POSITIVE CRANKCASE VENTILATION .....</b>     | <b>1552</b> | Accelerator Pedal Position Sensor .....            | 1570        | G         |
| Inspection .....                                | 1552        | Air Fuel Ratio (A/F) Sensor 1 .....                | 1570        |           |
| <b>REMOVAL AND INSTALLATION .....</b>           | <b>1553</b> | Battery Current Sensor (With Battery Tempera-      |             | H         |
| <b>ECM .....</b>                                | <b>1553</b> | ture Sensor) .....                                 | 1570        |           |
| Removal and Installation .....                  | 1553        | Camshaft Position Sensor .....                     | 1571        |           |
| <b>VVEL CONTROL MODULE .....</b>                | <b>1554</b> | Cooling Fan .....                                  | 1572        |           |
| Removal and Installation .....                  | 1554        | Crankshaft Position Sensor .....                   | 1572        |           |
| <b>FUEL PUMP CONTROL MODULE (FPCM) .....</b>    | <b>1555</b> | ECM .....  | 1572        |           |
| Removal and Installation .....                  | 1555        | Electric Throttle Control Actuator .....           | 1572        |           |
| <b>SERVICE DATA AND SPECIFICATIONS</b>          |             | Engine Coolant Temperature Sensor .....            | 1573        |           |
| <b>(SDS) .....</b>                              | <b>1556</b> | Engine Oil Pressure Sensor .....                   | 1574        | I         |
| <b>SERVICE DATA AND SPECIFICATIONS</b>          |             | Engine Oil Temperature Sensor .....                | 1574        |           |
| <b>(SDS) .....</b>                              | <b>1556</b> | EVAP Control System Pressure Sensor .....          | 1575        | J         |
| Idle Speed .....                                | 1556        | EVAP Canister Vent Control Valve .....             | 1575        |           |
| Ignition Timing .....                           | 1556        | EVAP Canister Purge Volume Control Solenoid        |             | K         |
| Calculated Load Value .....                     | 1556        | Valve .....  | 1575        |           |
| Mass Air Flow Sensor .....                      | 1556        | Exhaust Valve Timing Control Position Sensor ..... | 1575        |           |
| <b>VK56VD FOR MEXICO</b>                        |             | Exhaust Valve Timing Control Solenoid Valve .....  | 1576        |           |
| <b>PRECAUTION .....</b>                         | <b>1557</b> | Fuel Injector .....                                | 1576        |           |
| <b>PRECAUTIONS .....</b>                        | <b>1557</b> | Fuel Tank Temperature Sensor .....                 | 1576        | L         |
| Precaution for Supplemental Restraint System    |             | Heated Oxygen Sensor 2 .....                       | 1576        |           |
| (SRS) "AIR BAG" and "SEAT BELT PRE-TEN-         |             | High Pressure Fuel Pump .....                      | 1577        |           |
| SIONER" .....                                   | 1557        | Fuel Pump Control Module .....                     | 1578        | M         |
| Precaution for Procedure without Cowl Top Cover | 1557        | Fuel Rail Pressure Sensor .....                    | 1578        |           |
| Precautions For Xenon Headlamp Service .....    | 1557        | ICC Brake Switch .....                             | 1578        |           |
| On Board Diagnostic (OBD) System of Engine      |             | ICC Steering Switch .....                          | 1578        | N         |
| and A/T .....                                   | 1558        | Ignition Coil With Power Transistor .....          | 1578        |           |
| General Precautions .....                       | 1558        | Information Display .....                          | 1578        |           |
| <b>PREPARATION .....</b>                        | <b>1562</b> | Intake Valve Timing Control Solenoid Valve .....   | 1579        | O         |
|   |             | Knock Sensor .....                                 | 1579        |           |
|   |             | Low Fuel Pressure Sensor .....                     | 1579        |           |
|   |             | Low Pressure Fuel Pump .....                       | 1579        |           |
|   |             | Malfunction Indicator Lamp (MIL) .....             | 1580        | P         |
|   |             | Manifold Absolute Pressure Sensor .....            | 1580        |           |
|   |             | Mass Air Flow Sensor (With Intake Air Tempera-     |             |           |
|   |             | ture Sensor) .....                                 | 1580        |           |
|   |             | Power Steering Pressure (PSP) Sensor .....         | 1581        |           |
|   |             | Refrigerant Pressure Sensor .....                  | 1581        |           |
|   |             | Stop Lamp Switch .....                             | 1581        |           |
|   |             | VVEL Actuator Motor .....                          | 1581        |           |
|   |             | VVEL Actuator Motor Relay .....                    | 1581        |           |

|  |             |  |             |
|--|-------------|--|-------------|
| VVEL Control Module .....  | 1581        | <b>CAN COMMUNICATION .....</b>   | <b>1598</b> |
| VVEL Control Shaft Position Sensor .....                         | 1582        | CAN COMMUNICATION : System Description ..  | 1598        |
| <b>STRUCTURE AND OPERATION .....</b>                             | <b>1583</b> | <b>INFINITI DRIVE MODE SELECTOR .....</b>  | <b>1598</b> |
| Positive Crankcase Ventilation .....                             | 1583        | Infiniti Drive Mode Selector : System Description  | 1599        |
| On Board Refueling Vapor Recovery (ORVR) .....                   | 1584        | <b>ALTERNATOR POWER GENERATION VOLT-<br/>AGE VARIABLE CONTROL SYSTEM .....</b>                 | <b>1601</b> |
| <b>SYSTEM .....</b>  | <b>1585</b> | ALTERNATOR POWER GENERATION VOLT-<br>AGE VARIABLE CONTROL SYSTEM : System<br>Description ..... | 1601        |
| <b>ENGINE CONTROL SYSTEM .....</b>                               | <b>1585</b> | <b>HANDLING PRECAUTION .....</b>   | <b>1602</b> |
| ENGINE CONTROL SYSTEM : System Diagram                           | 1585        | Infiniti Drive Mode Selector .....   | 1602        |
| ENGINE CONTROL SYSTEM : System Descrip-<br>tion .....            | 1585        | <b>ON BOARD DIAGNOSTIC (OBD) SYSTEM ..</b>   | <b>1603</b> |
| <b>DIRECT INJECTION GASOLINE SYSTEM .....</b>                    | <b>1586</b> | Diagnosis Description .....  | 1603        |
| DIRECT INJECTION GASOLINE SYSTEM :<br>System Diagram .....       | 1586        | GST (Generic Scan Tool) .....  | 1603        |
| DIRECT INJECTION GASOLINE SYSTEM : Sys-<br>tem Description ..... | 1586        | <b>DIAGNOSIS SYSTEM (ECM) .....</b>  | <b>1604</b> |
| <b>FUEL PRESSURE CONTROL .....</b>                               | <b>1589</b> | <b>DIAGNOSIS DESCRIPTION .....</b>   | <b>1604</b> |
| FUEL PRESSURE CONTROL : System Diagram                           | 1589        | DIAGNOSIS DESCRIPTION : 1st Trip Detection<br>Logic and Two Trip Detection Logic .....         | 1604        |
| FUEL PRESSURE CONTROL : System Descrip-<br>tion .....            | 1589        | DIAGNOSIS DESCRIPTION : DTC and Freeze<br>Frame Data .....                                     | 1604        |
| <b>COOLING FAN CONTROL .....</b>                                 | <b>1590</b> | DIAGNOSIS DESCRIPTION : Counter System ..  | 1605        |
| COOLING FAN CONTROL : System Diagram ...                         | 1591        | DIAGNOSIS DESCRIPTION : Driving Pattern .....  | 1610        |
| COOLING FAN CONTROL : System Description                         | 1591        | DIAGNOSIS DESCRIPTION : System Readiness<br>Test (SRT) Code .....                              | 1610        |
| <b>ELECTRIC IGNITION SYSTEM .....</b>                            | <b>1591</b> | DIAGNOSIS DESCRIPTION : Malfunction Indica-<br>tor Lamp (MIL) .....                            | 1612        |
| ELECTRIC IGNITION SYSTEM :<br>System Diagram .....               | 1592        | On Board Diagnosis Function .....  | 1612        |
| ELECTRIC IGNITION SYSTEM : System De-<br>scription .....         | 1592        | CONSULT Function .....   | 1615        |
| <b>INTAKE VALVE TIMING CONTROL .....</b>                         | <b>1593</b> | <b>ECU DIAGNOSIS INFORMATION .....</b>   | <b>1624</b> |
| INTAKE VALVE TIMING CONTROL : System Di-<br>agram .....          | 1593        | <b>ECM .....</b>   | <b>1624</b> |
| INTAKE VALVE TIMING CONTROL : System De-<br>scription .....      | 1593        | Reference Value .....  | 1624        |
| <b>EXHAUST VALVE TIMING CONTROL .....</b>                        | <b>1593</b> | Fail-safe .....  | 1647        |
| EXHAUST VALVE TIMING CONTROL : System<br>Diagram .....           | 1594        | DTC Inspection Priority Chart .....  | 1649        |
| EXHAUST VALVE TIMING CONTROL : System<br>Description .....       | 1594        | DTC Index .....  | 1651        |
| <b>VVEL SYSTEM .....</b>   | <b>1594</b> | Test Value and Test Limit .....  | 1656        |
| VVEL SYSTEM : System Diagram .....                               | 1595        | <b>VVEL CONTROL MODULE .....</b>   | <b>1663</b> |
| VVEL SYSTEM : System Description .....                           | 1595        | Reference Value .....  | 1663        |
| <b>EVAPORATIVE EMISSION SYSTEM .....</b>                         | <b>1596</b> | <b>WIRING DIAGRAM .....</b>  | <b>1667</b> |
| EVAPORATIVE EMISSION SYSTEM : System<br>Diagram .....            | 1596        | <b>ENGINE CONTROL SYSTEM .....</b>   | <b>1667</b> |
| EVAPORATIVE EMISSION SYSTEM : System<br>Description .....        | 1596        | Wiring Diagram .....   | 1667        |
| <b>AIR CONDITIONING CUT CONTROL .....</b>                        | <b>1597</b> | <b>BASIC INSPECTION .....</b>  | <b>1675</b> |
| AIR CONDITIONING CUT CONTROL : System<br>Diagram .....           | 1597        | <b>DIAGNOSIS AND REPAIR WORKFLOW .....</b>   | <b>1675</b> |
| AIR CONDITIONING CUT CONTROL : System<br>Description .....       | 1597        | Work Flow .....  | 1675        |
|  |             | Diagnostic Work Sheet .....  | 1677        |
|  |             | <b>BASIC INSPECTION .....</b>  | <b>1679</b> |
|  |             | Work Procedure .....   | 1679        |



|  |             |   |             |    |
|--|-------------|---|-------------|----|
| <b>ADDITIONAL SERVICE WHEN REPLACING ECM</b> .....                 | <b>1683</b> | <b>U1001 CAN COMM CIRCUIT</b> .....                                       | <b>1714</b> | A  |
| Description .....  | 1683        | DTC Logic .....   | 1714        |    |
| Work Procedure .....   | 1683        | Diagnosis Procedure .....   | 1714        |    |
| <b>ADDITIONAL SERVICE WHEN REPLACING VVEL CONTROL MODULE</b> ..... | <b>1684</b> | <b>U1024 CAN COMM CIRCUIT</b> .....                                       | <b>1715</b> | EC |
| Description .....  | 1684        | DTC Logic .....   | 1715        |    |
| Work Procedure .....   | 1684        | Diagnosis Procedure .....   | 1715        |    |
| <b>ACCELERATOR PEDAL RELEASED POSITION LEARNING</b> .....          | <b>1685</b> | <b>P0011, P0021 IVT CONTROL</b> .....                                     | <b>1717</b> | C  |
| Description .....  | 1685        | DTC Logic .....   | 1717        |    |
| Work Procedure .....   | 1685        | Diagnosis Procedure .....   | 1718        |    |
| <b>THROTTLE VALVE CLOSED POSITION LEARNING</b> .....               | <b>1686</b> | Component Inspection (Intake Valve Timing Control Solenoid Valve) .....   | 1719        | D  |
| Description .....  | 1686        | <b>P0014, P0024 EVT CONTROL</b> .....                                     | <b>1721</b> | E  |
| Work Procedure .....   | 1686        | DTC Logic .....   | 1721        |    |
| <b>IDLE AIR VOLUME LEARNING</b> .....                              | <b>1687</b> | Diagnosis Procedure .....   | 1722        | F  |
| Description .....  | 1687        | Component Inspection (Echhaust Valve Timing Control Solenoid Valve) ..... | 1723        |    |
| Work Procedure .....   | 1687        | <b>P0031, P0032, P0051, P0052 A/F SENSOR 1 HEATER</b> .....               | <b>1725</b> | G  |
| <b>VVEL CONTROL SHAFT POSITION SENSOR ADJUSTMENT</b> .....         | <b>1689</b> | DTC Logic .....   | 1725        |    |
| Description .....  | 1689        | Diagnosis Procedure .....   | 1725        | H  |
| Work Procedure .....   | 1689        | Component Inspection (A/F Sensor 1 Heater) .....                          | 1726        |    |
| <b>MIXTURE RATIO SELF-LEARNING VALUE CLEAR</b> .....               | <b>1691</b> | <b>P0037, P0038, P0057, P0058 HO2S2 HEATER</b> .....                      | <b>1728</b> | I  |
| Description .....  | 1691        | DTC Logic .....   | 1728        |    |
| Work Procedure .....   | 1691        | Diagnosis Procedure .....   | 1728        | J  |
| <b>FUEL PRESSURE</b> .....   | <b>1692</b> | Component Inspection (HO2 Sensor 2 Heater) .....                          | 1730        |    |
| Work Procedure .....   | 1692        | <b>P0075, P0081 IVT CONTROL SOLENOID VALVE</b> .....                      | <b>1731</b> | K  |
| <b>HOW TO SET SRT CODE</b> .....                                   | <b>1695</b> | DTC Logic .....   | 1731        |    |
| Description .....  | 1695        | Diagnosis Procedure .....   | 1731        | L  |
| SRT Set Driving Pattern .....                                      | 1696        | Component Inspection (Intake Valve Timing Control Solenoid Valve) .....   | 1732        |    |
| Work Procedure .....   | 1698        | <b>P0078, P0084 EVT CONTROL SOLENOID VALVE</b> .....                      | <b>1734</b> | M  |
| <b>DTC/CIRCUIT DIAGNOSIS</b> .....                                 | <b>1700</b> | DTC Logic .....   | 1734        |    |
| <b>TROUBLE DIAGNOSIS - SPECIFICATION VALUE</b> .....               | <b>1700</b> | Diagnosis Procedure .....   | 1734        | N  |
| Description .....  | 1700        | Component Inspection (Echhaust Valve Timing Control Solenoid Valve) ..... | 1735        |    |
| Component Function Check .....                                     | 1700        | <b>P008A LOW FUEL PRESSURE CONTROL SYSTEM</b> .....                       | <b>1737</b> | O  |
| Diagnosis Procedure .....  | 1701        | DTC Logic .....   | 1737        |    |
| <b>POWER SUPPLY AND GROUND CIRCUIT</b> .....                       | <b>1707</b> | Diagnosis Procedure .....   | 1737        |    |
| Diagnosis Procedure .....  | 1707        | <b>P0087 FRP CONTROL SYSTEM</b> .....                                     | <b>1739</b> | P  |
| <b>U0101 CAN COMM CIRCUIT</b> .....                                | <b>1711</b> | DTC Logic .....   | 1739        |    |
| DTC Logic .....  | 1711        | Diagnosis Procedure .....   | 1740        |    |
| Diagnosis Procedure .....  | 1711        | Component Inspection (High Pressure Fuel Pump) .....                      | 1742        |    |
| <b>U0113, U1003 CAN COMM CIRCUIT</b> .....                         | <b>1712</b> | <b>P0088 FRP CONTROL SYSTEM</b> .....                                     | <b>1743</b> |    |
| DTC Logic .....  | 1712        | DTC Logic .....   | 1743        |    |
| Diagnosis Procedure .....  | 1712        | Diagnosis Procedure .....   | 1743        |    |

|  |             |  |             |
|--|-------------|--|-------------|
| Component Inspection (High Pressure Fuel Pump) .....           | 1744        | Component Function Check .....   | 1787        |
| <b>P0090 HIGH PRESSURE FUEL PUMP .....</b>                     | <b>1746</b> | Diagnosis Procedure .....  | 1788        |
| DTC Logic .....  | 1746        | Component Inspection (HO2 sensor 2) .....  | 1790        |
| Diagnosis Procedure .....                                      | 1746        | <b>P0139, P0159 HO2S2 .....</b>  | <b>1793</b> |
| Component Inspection (High Pressure Fuel Pump) .....           | 1747        | DTC Logic .....  | 1793        |
| <b>P0102, P0103, P010C, P010D MAF SENSOR</b>                   | <b>1749</b> | Component Function Check .....   | 1794        |
| DTC Logic .....  | 1749        | Diagnosis Procedure .....  | 1795        |
| Diagnosis Procedure .....                                      | 1750        | Component Inspection (HO2 sensor 2) .....  | 1796        |
| Component Inspection (MAF Sensor) .....                        | 1751        | <b>P0171, P0174 FUEL INJECTION SYSTEM FUNCTION .....</b>                           | <b>1799</b> |
| <b>P0112, P0113 IAT SENSOR .....</b>                           | <b>1755</b> | DTC Logic .....  | 1799        |
| DTC Logic .....  | 1755        | Diagnosis Procedure .....  | 1800        |
| Diagnosis Procedure .....                                      | 1755        | <b>P0172, P0175 FUEL INJECTION SYSTEM FUNCTION .....</b>                           | <b>1803</b> |
| Component Inspection (Intake Air Temperature Sensor) .....     | 1756        | DTC Logic .....  | 1803        |
| <b>P0117, P0118 ECT SENSOR .....</b>                           | <b>1757</b> | Diagnosis Procedure .....  | 1804        |
| DTC Logic .....  | 1757        | <b>P0190 FRP SENSOR .....</b>  | <b>1807</b> |
| Diagnosis Procedure .....                                      | 1757        | DTC Logic .....  | 1807        |
| Component Inspection (Engine Coolant Temperature Sensor) ..... | 1758        | Diagnosis Procedure .....  | 1807        |
| <b>P0122, P0123, P0227, P0228 TP SENSOR .....</b>              | <b>1759</b> | Component Inspection (Fuel Rail Pressure Sensor) .....                             | 1809        |
| DTC Logic .....  | 1759        | <b>P0197, P0198 EOT SENSOR .....</b>   | <b>1810</b> |
| Diagnosis Procedure .....                                      | 1759        | DTC Logic .....  | 1810        |
| Component Inspection (Throttle Position Sensor)                | 1760        | Diagnosis Procedure .....  | 1810        |
| <b>P0125 ECT SENSOR .....</b>                                  | <b>1762</b> | Component Inspection (Engine Oil Temperature Sensor) .....                         | 1811        |
| DTC Logic .....  | 1762        | <b>P0201, P0202, P0203, P0204, P0205, P0206, P0207, P0208 INJECTOR .....</b>       | <b>1812</b> |
| Diagnosis Procedure .....                                      | 1762        | DTC Logic .....  | 1812        |
| Component Inspection (Engine Coolant Temperature Sensor) ..... | 1763        | Diagnosis Procedure .....  | 1812        |
| <b>P0130, P0150 A/F SENSOR 1 .....</b>                         | <b>1764</b> | <b>P0222, P0223, P2132, P2133 TP SENSOR .....</b>                                  | <b>1813</b> |
| DTC Logic .....  | 1764        | DTC Logic .....  | 1813        |
| Component Function Check .....                                 | 1765        | Diagnosis Procedure .....  | 1813        |
| Diagnosis Procedure .....                                      | 1766        | Component Inspection (Throttle Position Sensor)                                    | 1814        |
| <b>P0131, P0151 A/F SENSOR 1 .....</b>                         | <b>1768</b> | <b>P0300, P0301, P0302, P0303, P0304, P0305, P0306, P0307, P0308 MISFIRE .....</b> | <b>1816</b> |
| DTC Logic .....  | 1768        | DTC Logic .....  | 1816        |
| Diagnosis Procedure .....                                      | 1769        | Diagnosis Procedure .....  | 1817        |
| <b>P0132, P0152 A/F SENSOR 1 .....</b>                         | <b>1771</b> | <b>P0327, P0328, P0332, P0333 KS .....</b>   | <b>1822</b> |
| DTC Logic .....  | 1771        | DTC Logic .....  | 1822        |
| Diagnosis Procedure .....                                      | 1772        | Diagnosis Procedure .....  | 1822        |
| <b>P0133, P0153 A/F SENSOR 1 .....</b>                         | <b>1774</b> | Component Inspection (Knock Sensor) .....  | 1823        |
| DTC Logic .....  | 1774        | <b>P0335 CKP SENSOR .....</b>  | <b>1824</b> |
| Diagnosis Procedure .....                                      | 1775        | DTC Logic .....  | 1824        |
| <b>P0137, P0157 HO2S2 .....</b>                                | <b>1779</b> | Diagnosis Procedure .....  | 1824        |
| DTC Logic .....  | 1779        | Component Inspection (Crankshaft Position Sensor) .....                            | 1826        |
| Component Function Check .....                                 | 1780        | <b>P0340, P0345 CMP SENSOR .....</b>   | <b>1828</b> |
| Diagnosis Procedure .....                                      | 1781        | DTC Logic .....  | 1828        |
| Component Inspection (HO2 sensor 2) .....                      | 1782        | Diagnosis Procedure .....  | 1829        |
| <b>P0138, P0158 HO2S2 .....</b>                                | <b>1785</b> |  |             |
| DTC Logic .....  | 1785        |  |             |

|  |             |   |             |    |
|--|-------------|---|-------------|----|
| Component Inspection (Camshaft Position Sensor) .....                          | 1831        | Diagnosis Procedure .....   | 1861        | A  |
| <b>P0420, P0430 THREE WAY CATALYST FUNCTION</b> .....                          | <b>1833</b> | <b>P062B ECM</b> .....  | <b>1862</b> | EC |
| DTC Logic .....  | 1833        | Description .....   | 1862        |    |
| Component Function Check .....   | 1834        | DTC Logic .....   | 1862        |    |
| Diagnosis Procedure .....  | 1835        | Diagnosis Procedure .....   | 1862        |    |
| <b>P0444 EVAP CANISTER PURGE VOLUME CONTROL SOLENOID VALVE</b> .....           | <b>1838</b> | <b>P0643 SENSOR POWER SUPPLY</b> .....                                    | <b>1863</b> | C  |
| DTC Logic .....  | 1838        | DTC Logic .....   | 1863        |    |
| Diagnosis Procedure .....  | 1838        | Diagnosis Procedure .....   | 1863        |    |
| Component Inspection (EVAP Canister Purge Volume Control Solenoid Valve) ..... | 1839        | <b>P0850 PNP SWITCH</b> .....   | <b>1865</b> | D  |
| <b>P0500 VSS</b> .....   | <b>1841</b> | Description .....   | 1865        |    |
| Description .....  | 1841        | DTC Logic .....   | 1865        |    |
| DTC Logic .....  | 1841        | Component Function Check .....  | 1866        | E  |
| Component Function Check .....   | 1842        | Diagnosis Procedure .....   | 1866        |    |
| Diagnosis Procedure .....  | 1842        | <b>P100A, P100B VVEL SYSTEM</b> .....                                     | <b>1868</b> | F  |
| <b>P0506 ISC SYSTEM</b> .....  | <b>1843</b> | DTC Logic .....   | 1868        |    |
| Description .....  | 1843        | Diagnosis Procedure .....   | 1868        |    |
| DTC Logic .....  | 1843        | Component Inspection (VVEL ACTUATOR MOTOR) .....                          | 1870        | G  |
| Diagnosis Procedure .....  | 1843        | Component Inspection (VVEL ACTUATOR SUB ASSEMBLY) .....                   | 1870        |    |
| <b>P0507 ISC SYSTEM</b> .....  | <b>1845</b> | <b>P1078, P1084 EVT CONTROL POSITION SENSOR</b> .....                     | <b>1872</b> | H  |
| Description .....  | 1845        | DTC Logic .....   | 1872        |    |
| DTC Logic .....  | 1845        | Diagnosis Procedure .....   | 1872        | I  |
| Diagnosis Procedure .....  | 1845        | Component Inspection (Exhaust Valve Timing Control Position Sensor) ..... | 1874        |    |
| <b>P0520 EOP SENSOR</b> .....  | <b>1847</b> | <b>P1087, P1088 VVEL SYSTEM</b> .....                                     | <b>1875</b> | J  |
| DTC Logic .....  | 1847        | DTC Logic .....   | 1875        |    |
| Diagnosis Procedure .....  | 1847        | Diagnosis Procedure .....   | 1875        |    |
| Component Inspection (EOP sensor) .....  | 1849        | <b>P1089, P1092 VVEL CONTROL SHAFT POSITION SENSOR</b> .....              | <b>1876</b> | K  |
| <b>P0524 ENGINE OIL PRESSURE</b> .....   | <b>1850</b> | DTC Logic .....   | 1876        |    |
| DTC Logic .....  | 1850        | Diagnosis Procedure .....   | 1876        | L  |
| Diagnosis Procedure .....  | 1851        | <b>P1090, P1093 VVEL ACTUATOR MOTOR</b> .....                             | <b>1879</b> | M  |
| <b>P0550 PSP SENSOR</b> .....  | <b>1853</b> | DTC Logic .....   | 1879        |    |
| DTC Logic .....  | 1853        | Diagnosis Procedure .....   | 1879        |    |
| Diagnosis Procedure .....  | 1853        | Component Inspection (VVEL ACTUATOR MOTOR) .....                          | 1881        | N  |
| Component Inspection (Power Steering Pressure Sensor) .....                    | 1855        | Component Inspection (VVEL ACTUATOR SUB ASSEMBLY) .....                   | 1881        |    |
| <b>P0603 ECM POWER SUPPLY</b> .....  | <b>1856</b> | <b>P1091 VVEL ACTUATOR MOTOR RELAY</b> .....                              | <b>1882</b> | O  |
| DTC Logic .....  | 1856        | DTC Logic .....   | 1882        |    |
| Diagnosis Procedure .....  | 1856        | Diagnosis Procedure .....   | 1882        |    |
| <b>P0605 ECM</b> .....   | <b>1858</b> | Component Inspection (VVEL Actuator Motor Relay) .....                    | 1884        | P  |
| DTC Logic .....  | 1858        | <b>P1197 OUT OF GAS</b> .....   | <b>1885</b> |    |
| Diagnosis Procedure .....  | 1858        | Description .....   | 1885        |    |
| <b>P0607 ECM</b> .....   | <b>1860</b> | DTC Logic .....   | 1885        |    |
| DTC Logic .....  | 1860        | Diagnosis Procedure .....   | 1886        |    |
| Diagnosis Procedure .....  | 1860        | <b>P1212 TCS COMMUNICATION LINE</b> .....                                 | <b>1887</b> |    |
| <b>P0611 ECM PROTECTION</b> .....  | <b>1861</b> |   |             |    |
| Description .....  | 1861        |   |             |    |
| DTC Logic .....  | 1861        |   |             |    |

|  |             |   |
|--|-------------|---|
| Description .....  | 1887        | Component Inspection (Battery Current Sensor) 1919      |
| DTC Logic .....  | 1887        |   |
| Diagnosis Procedure .....                                    | 1887        |   |
| <b>P1217 ENGINE OVER TEMPERATURE .....</b>                   | <b>1888</b> | <b>P1556, P1557 BATTERY TEMPERATURE SENSOR .....</b>    |
| DTC Logic .....  | 1888        | DTC Logic .....   |
| Component Function Check .....                               | 1888        | Diagnosis Procedure .....                               |
| Diagnosis Procedure .....                                    | 1889        | Component Inspection (Battery Temperature Sensor) ..... |
| <b>P1225, P1234 TP SENSOR .....</b>                          | <b>1891</b> | <b>P1564 ASCD STEERING SWITCH .....</b>                 |
| DTC Logic .....  | 1891        | DTC Logic .....   |
| Diagnosis Procedure .....                                    | 1891        | Diagnosis Procedure .....                               |
| <b>P1226, P1235 TP SENSOR .....</b>                          | <b>1892</b> | Component Inspection (ASCD Steering Switch) .....       |
| DTC Logic .....  | 1892        | <b>P1564 ICC STEERING SWITCH .....</b>                  |
| Diagnosis Procedure .....                                    | 1892        | DTC Logic .....   |
| <b>P1233, P2101 ELECTRIC THROTTLE CONTROL FUNCTION .....</b> | <b>1893</b> | Diagnosis Procedure .....                               |
| DTC Logic .....  | 1893        | Component Inspection (ICC Steering Switch) .....        |
| Diagnosis Procedure .....                                    | 1893        | <b>P1568 ICC FUNCTION .....</b>                         |
| Component Inspection (Electric Throttle Control Motor) ..... | 1895        | DTC Logic .....   |
| <b>P1236, P2118 THROTTLE CONTROL MOTOR .....</b>             | <b>1897</b> | Diagnosis Procedure .....                               |
| DTC Logic .....  | 1897        | <b>P1572 ICC BRAKE SWITCH .....</b>                     |
| Diagnosis Procedure .....                                    | 1897        | DTC Logic .....   |
| Component Inspection (Electric Throttle Control Motor) ..... | 1898        | Diagnosis Procedure .....                               |
| <b>P1238, P2119 ELECTRIC THROTTLE CONTROL ACTUATOR .....</b> | <b>1899</b> | Component Inspection (ICC Brake Switch) .....           |
| DTC Logic .....  | 1899        | Component Inspection (Stop Lamp Switch) .....           |
| Diagnosis Procedure .....                                    | 1899        | Component Inspection (ICC Brake Hold Relay) .....       |
| <b>P1239, P2135 TP SENSOR .....</b>                          | <b>1901</b> | <b>P1574 ASCD VEHICLE SPEED SENSOR .....</b>            |
| DTC Logic .....  | 1901        | Description .....                                       |
| Diagnosis Procedure .....                                    | 1901        | DTC Logic .....   |
| Component Inspection (Throttle Position Sensor) .....        | 1902        | Diagnosis Procedure .....                               |
| <b>P1550 BATTERY CURRENT SENSOR .....</b>                    | <b>1904</b> | <b>P1574 ICC VEHICLE SPEED SENSOR .....</b>             |
| DTC Logic .....  | 1904        | Description .....                                       |
| Diagnosis Procedure .....                                    | 1904        | DTC Logic .....   |
| Component Inspection (Battery Current Sensor) .....          | 1906        | Diagnosis Procedure .....                               |
| <b>P1551, P1552 BATTERY CURRENT SENSOR .....</b>             | <b>1908</b> | <b>P1606 VVEL CONTROL MODULE .....</b>                  |
| DTC Logic .....  | 1908        | DTC Logic .....   |
| Diagnosis Procedure .....                                    | 1908        | Diagnosis Procedure .....                               |
| Component Inspection (Battery Current Sensor) .....          | 1910        | <b>P1607 VVEL CONTROL MODULE .....</b>                  |
| <b>P1553 BATTERY CURRENT SENSOR .....</b>                    | <b>1912</b> | DTC Logic .....   |
| DTC Logic .....  | 1912        | Diagnosis Procedure .....                               |
| Diagnosis Procedure .....                                    | 1912        | <b>P1608 VVEL SENSOR POWER SUPPLY .....</b>             |
| Component Inspection (Battery Current Sensor) .....          | 1914        | DTC Logic .....   |
| <b>P1554 BATTERY CURRENT SENSOR .....</b>                    | <b>1916</b> | Diagnosis Procedure .....                               |
| DTC Logic .....  | 1916        | <b>P1715 INPUT SPEED SENSOR .....</b>                   |
| Component Function Check .....                               | 1916        | Description .....                                       |
| Diagnosis Procedure .....                                    | 1917        | DTC Logic .....   |
|  |             | Diagnosis Procedure .....                               |
|  |             | <b>P1805 BRAKE SWITCH .....</b>                         |
|  |             | DTC Logic .....   |
|  |             | Diagnosis Procedure .....                               |
|  |             | Component Inspection (Stop Lamp Switch) .....           |

|  |             |  |             |    |
|--|-------------|--|-------------|----|
| <b>P2100, P2103 THROTTLE CONTROL MOTOR RELAY</b> .....           | <b>1948</b> | Component Inspection (ICC Brake Hold Relay) ..                   | 1983        | A  |
| DTC Logic .....  | 1948        | <b>IGNITION SIGNAL</b> .....                                     | <b>1984</b> |    |
| Diagnosis Procedure .....  | 1948        | Component Function Check .....                                   | 1984        |    |
| <b>P2122, P2123 APP SENSOR</b> .....                             | <b>1950</b> | Diagnosis Procedure .....  | 1984        |    |
| DTC Logic .....  | 1950        | Component Inspection (Ignition Coil with Power Transistor) ..... | 1987        | EC |
| Diagnosis Procedure .....  | 1950        | Component Inspection (Condenser) .....                           | 1988        |    |
| Component Inspection (Accelerator Pedal Position Sensor) .....   | 1952        | <b>LOW PRESSURE FUEL PUMP</b> .....                              | <b>1989</b> | C  |
| <b>P2127, P2128 APP SENSOR</b> .....                             | <b>1953</b> | Component Function Check .....                                   | 1989        |    |
| DTC Logic .....  | 1953        | Diagnosis Procedure .....  | 1989        | D  |
| Diagnosis Procedure .....  | 1953        | Component Inspection (Low Pressure Fuel Pump) .....              | 1990        |    |
| Component Inspection (Accelerator Pedal Position Sensor) .....   | 1956        | Component Inspection (FPCM) .....                                | 1991        | E  |
| <b>P2138 APP SENSOR</b> .....                                    | <b>1957</b> | <b>MALFUNCTION INDICATOR LAMP</b> .....                          | <b>1992</b> |    |
| DTC Logic .....  | 1957        | Component Function Check .....                                   | 1992        | F  |
| Diagnosis Procedure .....  | 1957        | Diagnosis Procedure .....  | 1992        |    |
| Component Inspection (Accelerator Pedal Position Sensor) .....   | 1960        | <b>MAP (MANIFOLD ABSOLUTE PRESSURE) SENSOR</b> .....             | <b>1993</b> | G  |
| <b>P2539 LOW FUEL PRESSURE SENSOR</b> .....                      | <b>1962</b> | Component Function Check .....                                   | 1993        |    |
| DTC Logic .....  | 1962        | Diagnosis Procedure .....  | 1993        |    |
| Diagnosis Procedure .....  | 1962        | Component Inspection .....                                       | 1995        | H  |
| Component Inspection .....                                       | 1964        | <b>ON BOARD REFUELING VAPOR RECOVERY (ORVR)</b> .....            | <b>1997</b> |    |
| <b>COOLING FAN</b> .....   | <b>1966</b> | Component Function Check .....                                   | 1997        | I  |
| Description .....  | 1966        | Diagnosis Procedure .....  | 1997        |    |
| Component Function Check .....                                   | 1966        | Component Inspection (EVAP Vapor Cut Valve) .....                | 1999        | J  |
| Diagnosis Procedure .....  | 1966        | <b>REFRIGERANT PRESSURE SENSOR</b> .....                         | <b>2001</b> |    |
| Component Inspection (Cooling Fan Motor) .....                   | 1969        | Component Function Check .....                                   | 2001        |    |
| Component Inspection (Cooling Fan Relay) .....                   | 1970        | Diagnosis Procedure .....  | 2001        | K  |
| <b>ELECTRICAL LOAD SIGNAL</b> .....                              | <b>1971</b> | <b>SYMPTOM DIAGNOSIS</b> .....                                   | <b>2003</b> |    |
| Description .....  | 1971        | <b>ENGINE CONTROL SYSTEM SYMPTOMS</b> ..                         | <b>2003</b> | L  |
| Component Function Check .....                                   | 1971        | Symptom Table .....  | 2003        |    |
| Diagnosis Procedure .....  | 1971        | <b>Infiniti Drive Mode Selector</b> .....                        | <b>2007</b> |    |
| <b>EVAP CONTROL SYSTEM PRESSURE SENSOR</b> .....                 | <b>1973</b> | Symptom Table .....  | 2007        | M  |
| Component Function Check .....                                   | 1973        | <b>NORMAL OPERATING CONDITION</b> .....                          | <b>2008</b> |    |
| Diagnosis Procedure .....  | 1973        | Description .....  | 2008        | N  |
| Component Inspection (EVAP Control System Pressure Sensor) ..... | 1974        | <b>PERIODIC MAINTENANCE</b> .....                                | <b>2009</b> |    |
| <b>FUEL INJECTOR</b> .....                                       | <b>1976</b> | <b>IDLE SPEED</b> .....  | <b>2009</b> | O  |
| Component Function Check .....                                   | 1976        | Inspection .....   | 2009        |    |
| Diagnosis Procedure .....  | 1976        | <b>IGNITION TIMING</b> .....                                     | <b>2010</b> |    |
| Component Inspection .....                                       | 1977        | Inspection .....   | 2010        | P  |
| <b>HIGH PRESSURE FUEL PUMP</b> .....                             | <b>1979</b> | <b>EVAP LEAK CHECK</b> .....                                     | <b>2011</b> |    |
| Component Function Check .....                                   | 1979        | Inspection .....   | 2011        |    |
| Diagnosis Procedure .....  | 1979        | <b>POSITIVE CRANKCASE VENTILATION</b> .....                      | <b>2012</b> |    |
| Component Inspection .....                                       | 1980        | Inspection .....   | 2012        |    |
| <b>ICC BRAKE SWITCH</b> .....                                    | <b>1981</b> | <b>REMOVAL AND INSTALLATION</b> .....                            | <b>2013</b> |    |
| Component Function Check .....                                   | 1981        |  |             |    |
| Diagnosis Procedure .....  | 1981        |  |             |    |
| Component Inspection (ICC Brake Switch) .....                    | 1982        |  |             |    |

---

|   |             |
|---|-------------|
| <b>ECM</b> .....                          | <b>2013</b> |
| Removal and Installation .....            | 2013        |
| <b>VVEL CONTROL MODULE</b> .....          | <b>2014</b> |
| Removal and Installation .....            | 2014        |
| <b>FUEL PUMP CONTROL MODULE (FPCM)</b> .. | <b>2015</b> |
| Removal and Installation .....            | 2015        |

|  |             |
|--|-------------|
| <b>SERVICE DATA AND SPECIFICATIONS (SDS)</b> ..... | <b>2016</b> |
| <b>SERVICE DATA AND SPECIFICATIONS (SDS)</b> ..... | <b>2016</b> |
| Idle Speed .....                                   | 2016        |
| Ignition Timing .....                              | 2016        |
| Calculated Load Value .....                        | 2016        |
| Mass Air Flow Sensor .....                         | 2016        |

PRECAUTION

PRECAUTIONS

Precaution for Supplemental Restraint System (SRS) "AIR BAG" and "SEAT BELT PRE-TENSIONER"

INFOID:000000006882729

The Supplemental Restraint System such as "AIR BAG" and "SEAT BELT PRE-TENSIONER", used along with a front seat belt, helps to reduce the risk or severity of injury to the driver and front passenger for certain types of collision. This system includes seat belt switch inputs and dual stage front air bag modules. The SRS system uses the seat belt switches to determine the front air bag deployment, and may only deploy one front air bag, depending on the severity of a collision and whether the front occupants are belted or unbelted. Information necessary to service the system safely is included in the "SRS AIR BAG" and "SEAT BELT" of this Service Manual.

**WARNING:**

Always observe the following items for preventing accidental activation.

- To avoid rendering the SRS inoperative, which could increase the risk of personal injury or death in the event of a collision that would result in air bag inflation, all maintenance must be performed by an authorized NISSAN/INFINITI dealer.
- Improper maintenance, including incorrect removal and installation of the SRS, can lead to personal injury caused by unintentional activation of the system. For removal of Spiral Cable and Air Bag Module, see "SRS AIR BAG".
- Never use electrical test equipment on any circuit related to the SRS unless instructed to in this Service Manual. SRS wiring harnesses can be identified by yellow and/or orange harnesses or harness connectors.

PRECAUTIONS WHEN USING POWER TOOLS (AIR OR ELECTRIC) AND HAMMERS

**WARNING:**

Always observe the following items for preventing accidental activation.

- When working near the Air Bag Diagnosis Sensor Unit or other Air Bag System sensors with the ignition ON or engine running, never use air or electric power tools or strike near the sensor(s) with a hammer. Heavy vibration could activate the sensor(s) and deploy the air bag(s), possibly causing serious injury.
- When using air or electric power tools or hammers, always switch the ignition OFF, disconnect the battery, and wait at least 3 minutes before performing any service.

Precaution for Procedure without Cowl Top Cover

INFOID:000000006882730

When performing the procedure after removing cowl top cover, cover the lower end of windshield with urethane, etc.

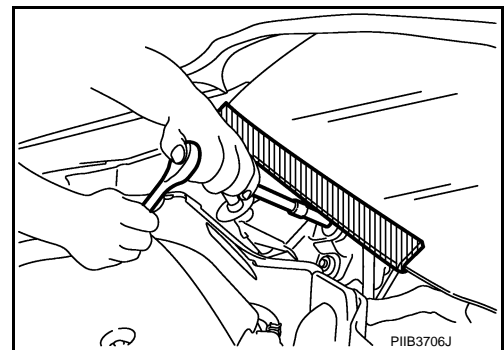

Precautions For Xenon Headlamp Service

INFOID:000000006882731

**WARNING:**

Comply with the following warnings to prevent any serious accident.

- Disconnect the battery cable (negative terminal) or the power supply fuse before installing, removing, or touching the xenon headlamp (bulb included). The xenon headlamp contains high-voltage generated parts.
- Never work with wet hands.
- Check the xenon headlamp ON-OFF status after assembling it to the vehicle. Never turn the xenon headlamp ON in other conditions. Connect the power supply to the vehicle-side connector.

A  
EC  
C  
D  
E  
F  
G  
H  
I  
J  
K  
L  
M  
N  
O  
P

# PRECAUTIONS

[VQ37VHR FOR USA AND CANADA]

## < PRECAUTION >

(Turning it ON outside the lamp case may cause fire or visual impairments.)

- Never touch the bulb glass immediately after turning it OFF. It is extremely hot.

### CAUTION:

Comply with the following cautions to prevent any error and malfunction.

- Install the xenon bulb securely. (Insufficient bulb socket installation may melt the bulb, the connector, the housing, etc. by high-voltage leakage or corona discharge.)
- Never perform HID circuit inspection with a tester.
- Never touch the xenon bulb glass with hands. Never put oil and grease on it.
- Dispose of the used xenon bulb after packing it in thick vinyl without breaking it.
- Never wipe out dirt and contamination with organic solvent (thinner, gasoline, etc.).

## On Board Diagnostic (OBD) System of Engine and A/T

INFOID:000000006882732

The ECM has an on board diagnostic system. It will illuminate the malfunction indicator lamp (MIL) to warn the driver of a malfunction causing emission deterioration.

### CAUTION:

- Always turn the ignition switch OFF and disconnect the negative battery cable before any repair or inspection work. The open/short circuit of related switches, sensors, solenoid valves, etc. will cause the MIL to illuminate.
- Always connect and lock the connectors securely after work. A loose (unlocked) connector will cause the MIL to illuminate due to the open circuit. (Be sure the connector is free from water, grease, dirt, bent terminals, etc.)
- Certain systems and components, especially those related to OBD, may use a new style slide-locking type harness connector. For description and how to disconnect, refer to [PG-5, "Harness Connector"](#).
- Always route and secure the harnesses properly after work. The interference of the harness with a bracket, etc. may cause the MIL to illuminate due to the short circuit.
- Always connect rubber tubes properly after work. A misconnected or disconnected rubber tube may cause the MIL to illuminate due to the malfunction of the EVAP system or fuel injection system, etc.
- Always erase the unnecessary malfunction information (repairs completed) from the ECM and TCM (Transmission control module) before returning the vehicle to the customer.

## General Precautions

INFOID:000000006882733

- Always use a 12 volt battery as power source.
- Never attempt to disconnect battery cables while engine is running.
- Before connecting or disconnecting the ECM harness connector, turn ignition switch OFF and disconnect negative battery cable. Failure to do so may damage the ECM because battery voltage is applied to ECM even if ignition switch is turned OFF.
- Before removing parts, turn ignition switch OFF and then disconnect negative battery cable.

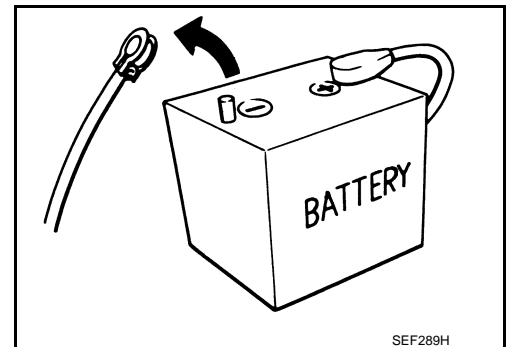

- Never disassemble ECM.
- If a battery cable is disconnected, the memory will return to the ECM value.  
The ECM will now start to self-control at its initial value. Thus, engine operation can vary slightly in this case. However, this is not an indication of a malfunction. Never replace parts because of a slight variation.
- If the battery is disconnected, the following emission-related diagnostic information will be cleared within 24 hours.
  - Diagnostic trouble codes
  - 1st trip diagnostic trouble codes
  - Freeze frame data
  - 1st trip freeze frame data
  - System readiness test (SRT) codes
  - Test values

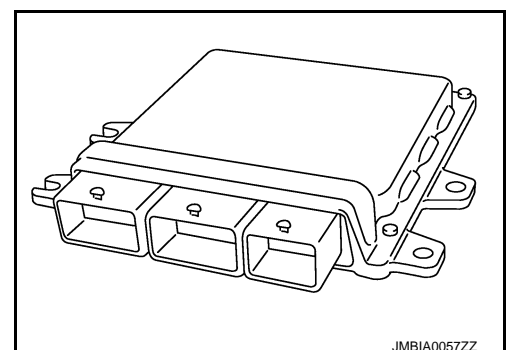



# PRECAUTIONS

[VQ37VHR FOR USA AND CANADA]

## < PRECAUTION >

- When connecting ECM harness connector (A), fasten (B) it securely with a lever as far as it will go as shown in the figure.
  - 1 : ECM
  - C : Loosen

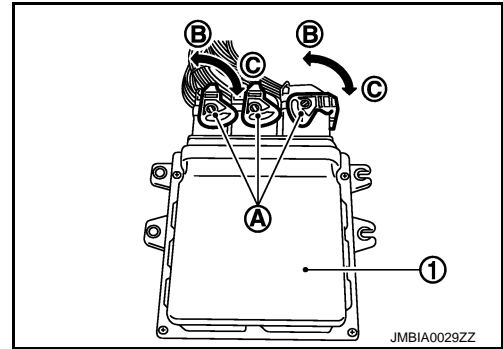

- When connecting or disconnecting pin connectors into or from ECM, never damage pin terminals (bends or break). Make sure that there are not any bends or breaks on ECM pin terminal, when connecting pin connectors.
- Securely connect ECM harness connectors. A poor connection can cause an extremely high (surge) voltage to develop in coil and condenser, thus resulting in damage to ICs.
- Keep engine control system harness at least 10 cm (4 in) away from adjacent harness, to prevent engine control system malfunctions due to receiving external noise, degraded operation of ICs, etc.
- Keep engine control system parts and harness dry.
- Before replacing ECM, perform ECM Terminals and Reference Value inspection and make sure ECM functions properly. Refer to [EC-98. "Reference Value"](#).
- Handle mass air flow sensor carefully to avoid damage.
- Never clean mass air flow sensor with any type of detergent.
- Never disassemble electric throttle control actuator.
- Even a slight leak in the air intake system can cause serious incidents.
- Never shock or jar the camshaft position sensor (PHASE), crankshaft position sensor (POS).

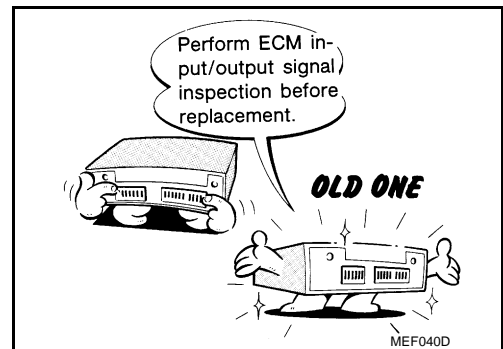
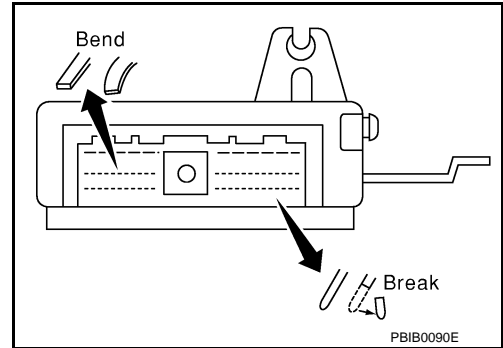

- After performing each TROUBLE DIAGNOSIS, perform DTC Confirmation Procedure or Component Function Check. The DTC should not be displayed in the DTC Confirmation Procedure if the repair is completed. The Component Function Check should be a good result if the repair is completed.

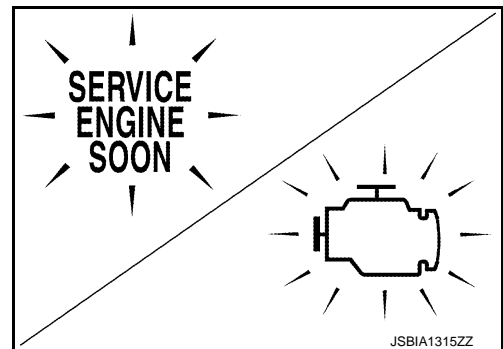

A  
EC  
C  
D  
E  
F  
G  
H  
I  
J  
K  
L  
M  
N  
O  
P

## PRECAUTIONS

[VQ37VHR FOR USA AND CANADA]

### < PRECAUTION >

- When measuring ECM signals with a circuit tester, never allow the two tester probes to contact. Accidental contact of probes will cause a short circuit and damage the ECM power transistor.

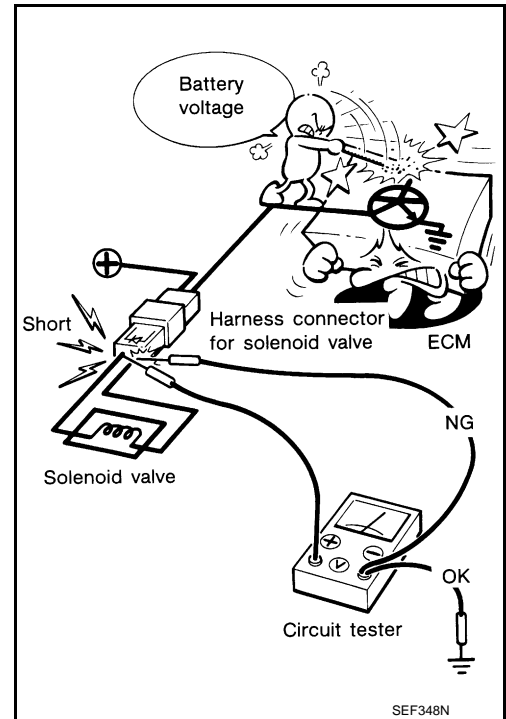

- B1 indicates bank 1, B2 indicates bank 2 as shown in the figure.
- Never operate fuel pump when there is no fuel in lines.
- Tighten fuel hose clamps to the specified torque.

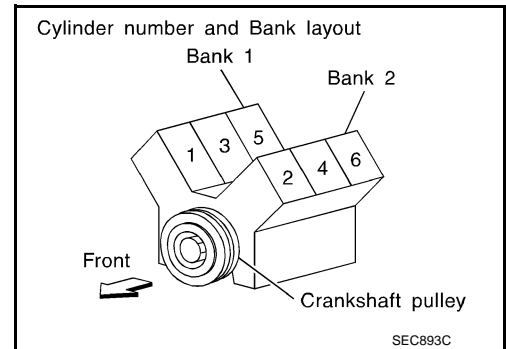

- Never depress accelerator pedal when starting.
- Immediately after starting, never rev up engine unnecessarily.
- Never rev up engine just prior to shutdown.

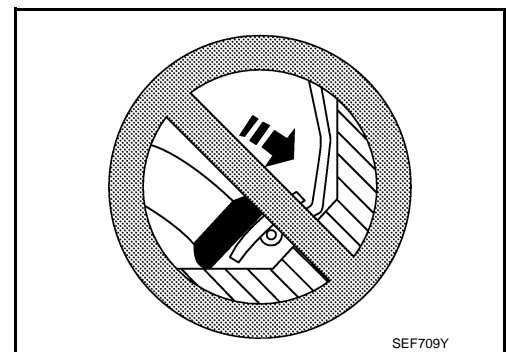

## PRECAUTIONS

[VQ37VHR FOR USA AND CANADA]

### < PRECAUTION >

- When installing C.B. ham radio or a mobile phone, be sure to observe the following as it may adversely affect electronic control systems depending on installation location.
- Keep the antenna as far as possible from the electronic control units.
- Keep the antenna feeder line more than 20 cm (8 in) away from the harness of electronic controls.  
Never let them run parallel for a long distance.
- Adjust the antenna and feeder line so that the standing-wave ratio can be kept smaller.
- Be sure to ground the radio to vehicle body.

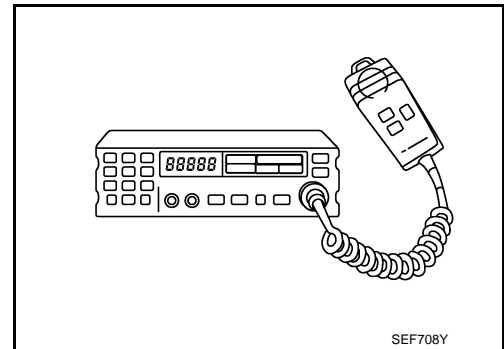

A

EC

C

D

E

F

G

H

I

J

K

L

M

N

O

P

# PREPARATION

< PREPARATION >

[VQ37VHR FOR USA AND CANADA]

## PREPARATION

### PREPARATION

#### Special Service Tools

INFOID:000000006882734

**NOTE:**

The actual shapes of Kent-Moore tools may differ from those of special service tools illustrated here.

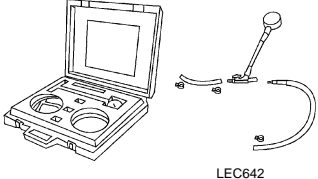
| Tool number<br>(Kent-Moore No.)<br>Tool name   | Description          |
|--|----------------------|
| (J-44321)<br>Fuel pressure gauge<br>kit<br> <p style="text-align: center;">LEC642</p> | Checks fuel pressure |

#### Commercial Service Tools

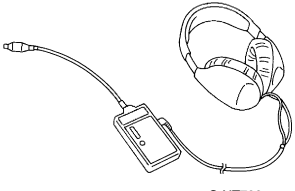
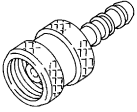
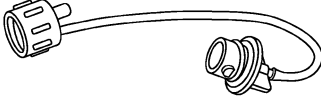
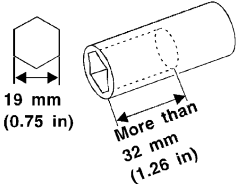

INFOID:000000006882735

| Tool name<br>(Kent-Moore No.)  | Description  |
|--|--|
| Leak detector<br>i.e.: (J-41416)<br> <p style="text-align: center;">S-NT703</p>                    | Locates the EVAP leak                                  |
| EVAP service port<br>adapter<br>i.e.: (J-41413-OB)<br> <p style="text-align: center;">S-NT704</p> | Applies positive pressure through EVAP service port    |
| Fuel filler cap adapter<br>i.e.: (MLR-8382)<br> <p style="text-align: center;">S-NT815</p>        | Checks fuel tank vacuum relief valve opening pressure  |
| Socket wrench<br> <p style="text-align: center;">S-NT705</p>                                      | Removes and installs engine coolant temperature sensor |

# PREPARATION

< PREPARATION >

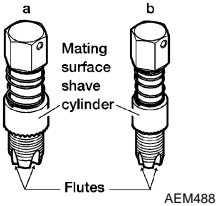
[VQ37VHR FOR USA AND CANADA]

| Tool name<br>(Kent-Moore No.)   | Description  | A                          |
|---|--|----------------------------|
| <p>Oxygen sensor thread cleaner<br/>i.e.: (J-43897-18)<br/>(J-43897-12)</p>                                | <p>Reconditions the exhaust system threads before installing a new oxygen sensor. Use with anti-seize lubricant shown below.<br/><b>a: 18 mm diameter with pitch 1.5 mm for Zirconia Oxygen Sensor</b><br/><b>b: 12 mm diameter with pitch 1.25 mm for Titania Oxygen Sensor</b></p> | <p>EC</p> <p>C</p>         |
| <p>Anti-seize lubricant<br/>i.e.: (Permatex™ 133AR or equivalent meeting MIL specification MIL-A-907)</p>  | <p>Lubricates oxygen sensor thread cleaning tool when reconditioning exhaust system threads.</p>   | <p>D</p> <p>E</p> <p>F</p> |

G

H

I

J

K

L

M

N

O

P

# COMPONENT PARTS

< SYSTEM DESCRIPTION >

[VQ37VHR FOR USA AND CANADA]

## SYSTEM DESCRIPTION

### COMPONENT PARTS

#### ENGINE CONTROL SYSTEM

#### ENGINE CONTROL SYSTEM : Component Parts Location

INFOID:000000006882736

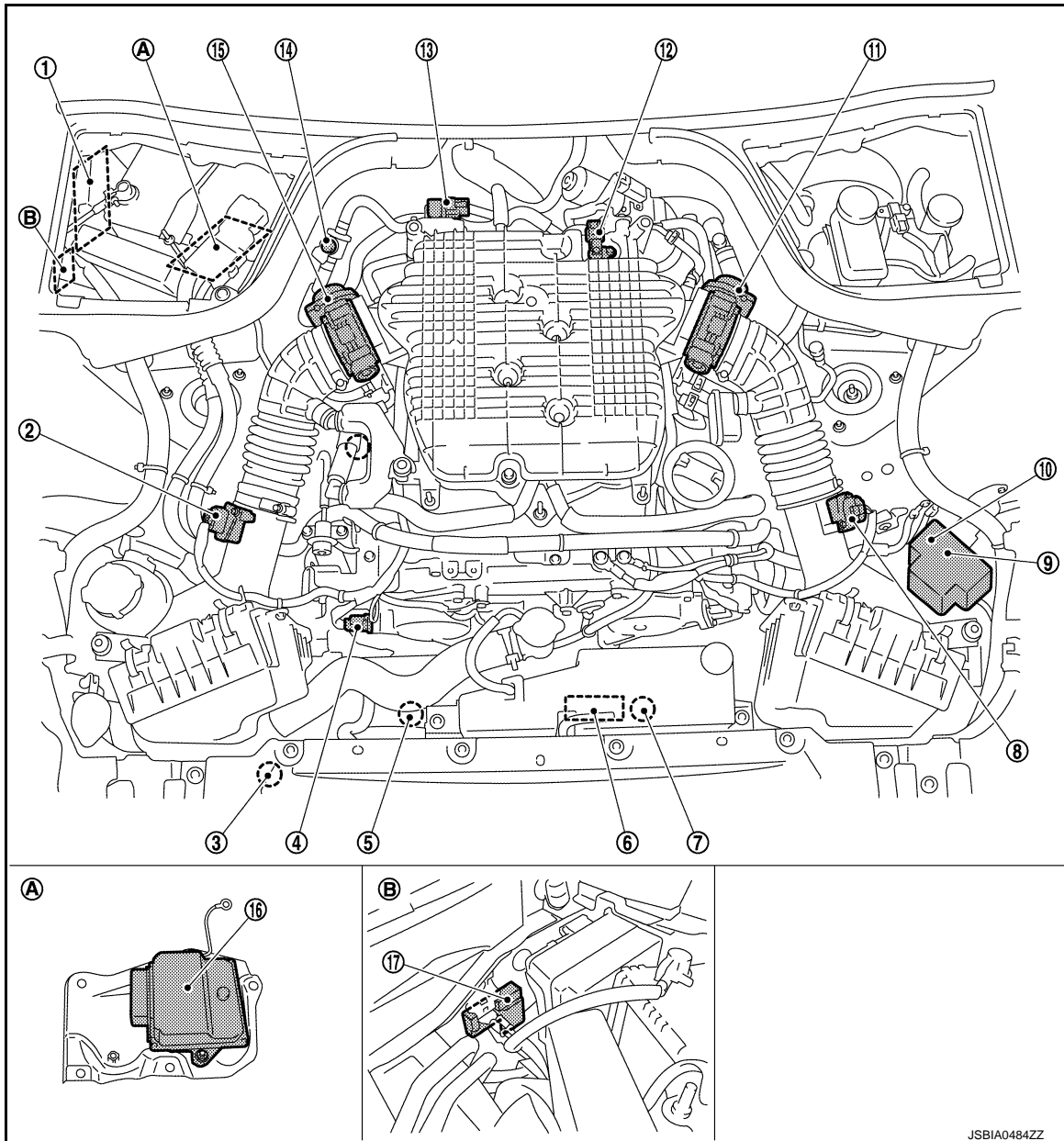

- |   |   |   |
|---|---|---|
| 1. IPDM E/R<br><a href="#">PCS-5, "IPDM E/R : Component Parts Location"</a> | 2. Mass air flow sensor (with intake air temperature sensor) (bank 1) | 3. Refrigerant pressure sensor                  |
| 4. Camshaft position sensor (PHASE) (bank 1)                                | 5. Cooling fan motor-2  | 6. Cooling fan control module                   |
| 7. Cooling fan motor-1  | 8. Mass air flow sensor (bank 2)                                      | 9. VVEL actuator motor relay                    |
| 10. Cooling fan relay   | 11. Electric throttle control actuator (bank 2)                       | 12. Manifold absolute pressure (MAP) sensor     |
| 13. EVAP canister purge volume control solenoid valve                       | 14. EVAP service port   | 15. Electric throttle control actuator (bank 1) |

# COMPONENT PARTS

[VQ37VHR FOR USA AND CANADA]

## < SYSTEM DESCRIPTION >

- 16. VVEL control module
- 17. Battery current sensor (with battery temperature sensor)
- A. Under the battery tray (View with upside-down)
- B. Body side in battery case

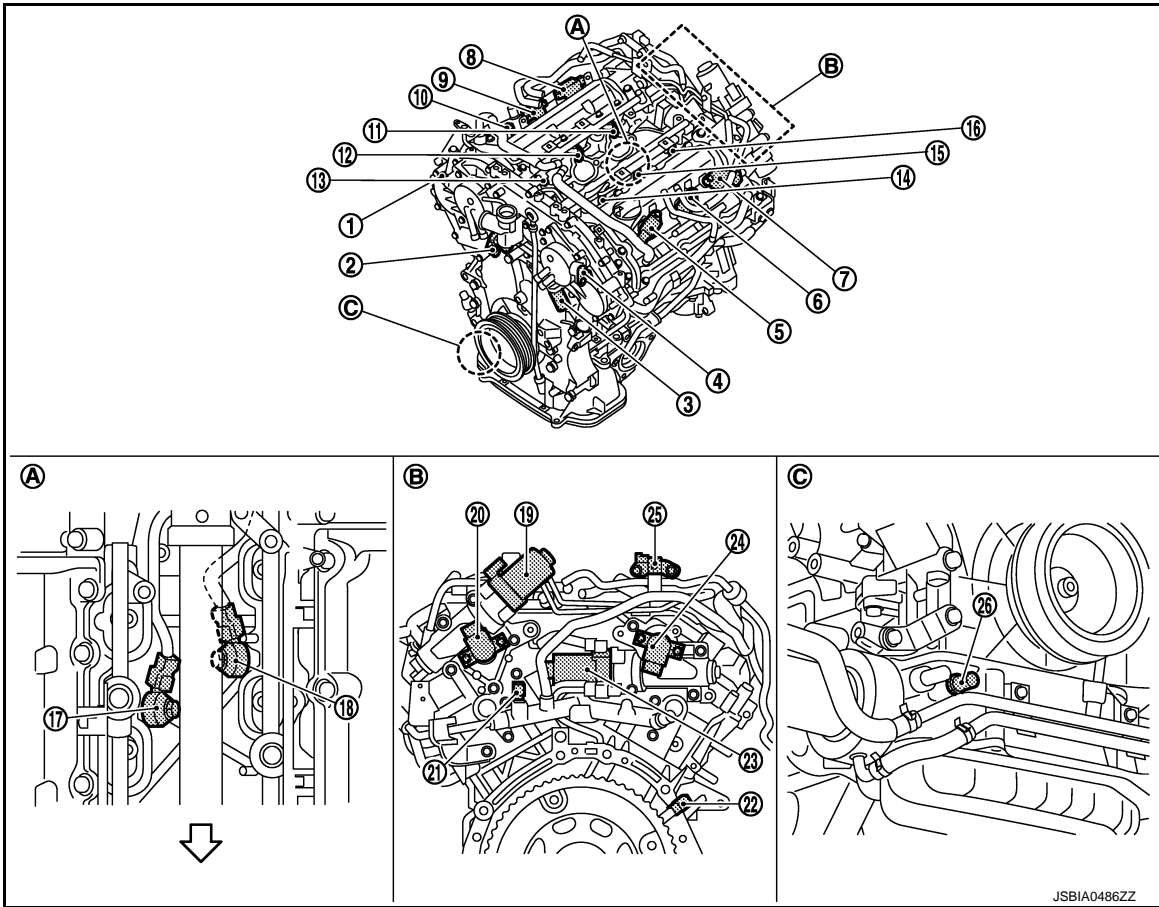

- 1. Camshaft position sensor (PHASE) (bank 1)
  - 2. Intake valve timing control solenoid valve (bank 1)
  - 3. Intake valve timing control solenoid valve (bank 2)
  - 4. Camshaft position sensor (PHASE) (bank 2)
  - 5. Ignition coil (with power transistor) and spark plug (No.2 cylinder)
  - 6. Ignition coil (with power transistor) and spark plug (No.4 cylinder)
  - 7. Ignition coil (with power transistor) and spark plug (No.6 cylinder)
  - 8. Ignition coil (with power transistor) and spark plug (No.5 cylinder)
  - 9. Ignition coil (with power transistor) and spark plug (No.3 cylinder)
  - 10. Ignition coil (with power transistor) and spark plug (No.1 cylinder)
  - 11. Fuel injector (No.5 cylinder)
  - 12. Fuel injector (No.3 cylinder)
  - 13. Fuel injector (No.1 cylinder)
  - 14. Fuel injector (No.2 cylinder)
  - 15. Fuel injector (No.4 cylinder)
  - 16. Fuel injector (No.6 cylinder)
  - 17. Knock sensor (bank 1)
  - 18. Knock sensor (bank 2)
  - 19. VVEL actuator motor (bank 2)
  - 20. VVEL control shaft position sensor (bank 2)
  - 21. Engine coolant temperature sensor
  - 22. Crankshaft position sensor (POS)
  - 23. VVEL actuator motor (bank 1)
  - 24. VVEL control shaft position sensor (bank 1)
  - 25. EVAP canister purge volume control solenoid valve
  - 26. Engine oil temperature sensor
  - A. Top view of the engine (View with intake manifold is removed)
  - B. Rear view of the engine
  - C. Front view of the engine
- ← Engine front

A  
EC  
C  
D  
E  
F  
G  
H  
I  
J  
K  
L  
M  
N  
O  
P

# COMPONENT PARTS

< SYSTEM DESCRIPTION >

[VQ37VHR FOR USA AND CANADA]

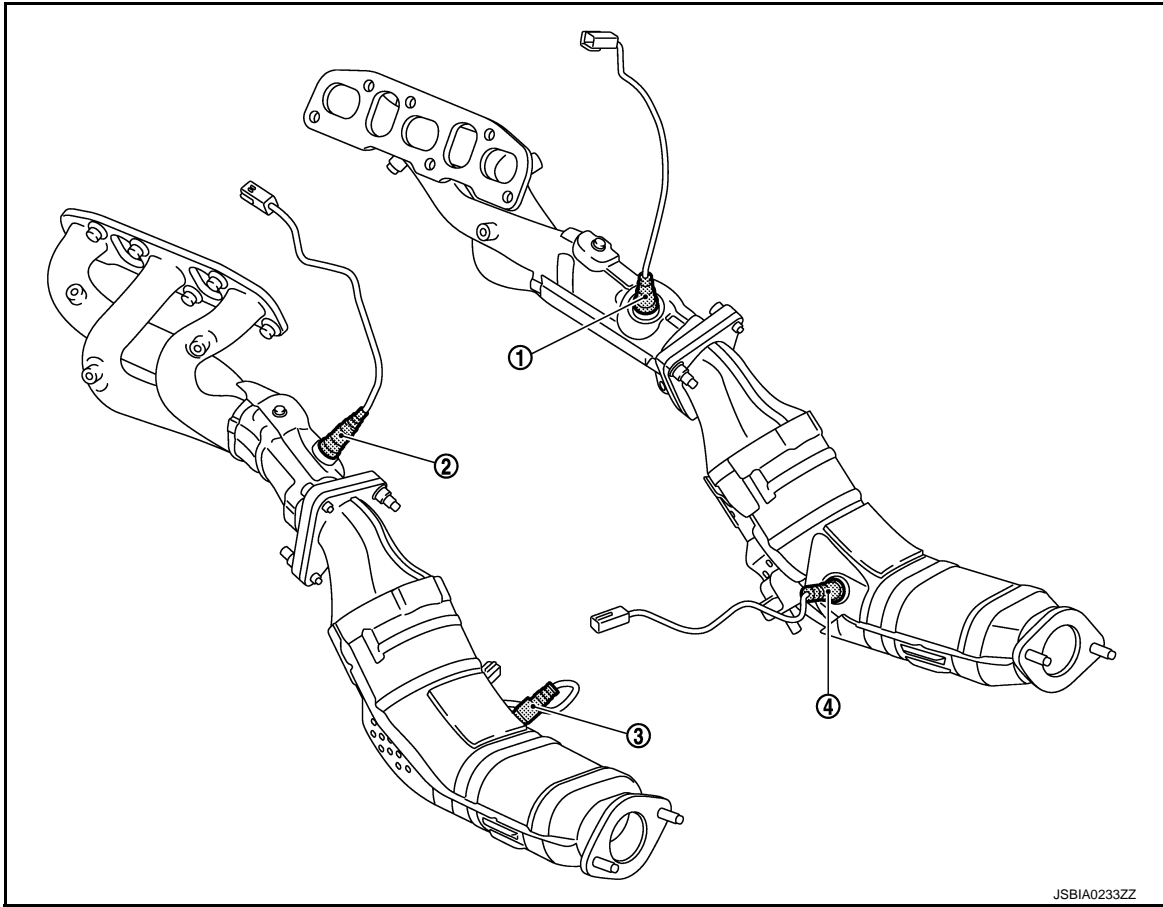

JSBIA0233ZZ

- 1. A/F sensor 1 (bank 1)
- 2. A/F sensor 1 (bank 2)
- 3. Heated oxygen sensor 2 (bank 2)
- 4. Heated oxygen sensor 2 (bank 1)



# COMPONENT PARTS

< SYSTEM DESCRIPTION >

[VQ37VHR FOR USA AND CANADA]

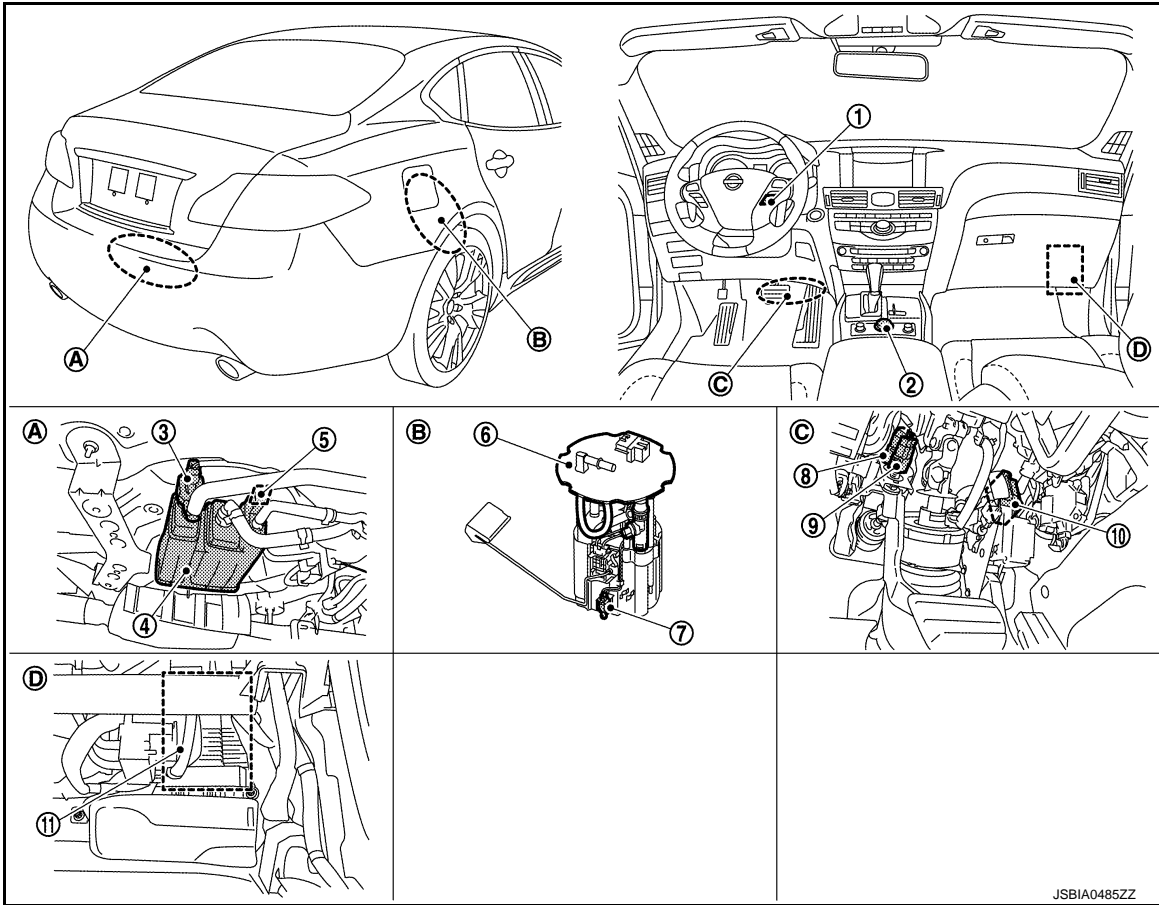

- |                                       |  |   |
|---------------------------------------|--|---|
| 1. ASCD steering switch               | 2. Drive mode select switch            | 3. EVAP canister vent control valve     |
| 4. EVAP canister                      | 5. EVAP control system pressure sensor | 6. Fuel level sensor unit and fuel pump |
| 7. Fuel tank temperature sensor       | 8. Stop lamp switch                    | 9. ASCD brake switch                    |
| 10. Accelerator pedal position sensor | 11. ECM                                |   |
| A. Under the spare tire housing       | B. Rear seat (lower right)             | C. Around the pedal                     |
| D. Lower right of the glove box       |  |   |

## ENGINE CONTROL SYSTEM : Component Description

INFOID:000000006882737

| Component                          | Reference   |
|------------------------------------|---|
| A/F sensor 1                       | <a href="#">EC-44, "Air Fuel Ratio Sensor 1"</a>                                  |
| A/F sensor 1 heater                | <a href="#">EC-44, "Air Fuel Ratio Sensor 1 Heater"</a>                           |
| Accelerator pedal position sensor  | <a href="#">EC-44, "Accelerator Pedal Position Sensor"</a>                        |
| ASCD brake switch                  | <a href="#">EC-461, "Description"</a>   |
| ASCD steering switch               | <a href="#">EC-45, "ASCD Steering Switch"</a>                                     |
| Battery current sensor             | <a href="#">EC-45, "Battery Current Sensor (With Battery Temperature Sensor)"</a> |
| Camshaft position sensor (PHASE)   | <a href="#">EC-46, "Camshaft Position Sensor (PHASE)"</a>                         |
| Cooling fan control module         | <a href="#">EC-46, "Cooling Fan"</a>  |
| Cooling fan motor                  | <a href="#">EC-46, "Cooling Fan"</a>  |
| Crankshaft position sensor (POS)   | <a href="#">EC-47, "Crankshaft Position Sensor (POS)"</a>                         |
| Electric throttle control actuator | <a href="#">EC-47, "Electric Throttle Control Actuator"</a>                       |
| Engine coolant temperature sensor  | <a href="#">EC-47, "Engine Coolant Temperature Sensor"</a>                        |

## COMPONENT PARTS

< SYSTEM DESCRIPTION >

[VQ37VHR FOR USA AND CANADA]

| Component   | Reference  |
|---|--|
| Engine oil temperature sensor                     | <a href="#">EC-48, "Engine Oil Temperature Sensor"</a>                     |
| EVAP canister purge volume control solenoid valve | <a href="#">EC-48, "EVAP Canister Purge Volume Control Solenoid Valve"</a> |
| EVAP canister vent control valve                  | <a href="#">EC-49, "EVAP Canister Vent Control Valve"</a>                  |
| EVAP control system pressure sensor               | <a href="#">EC-49, "EVAP Control System Pressure Sensor"</a>               |
| Fuel injector                                     | <a href="#">EC-49, "Fuel Injector"</a>                                     |
| Fuel level sensor                                 | <a href="#">EC-49, "Fuel Level Sensor"</a>                                 |
| Fuel pump   | <a href="#">EC-49, "Fuel Pump"</a>   |
| Fuel tank temperature sensor                      | <a href="#">EC-50, "Fuel Tank Temperature Sensor"</a>                      |
| Heated oxygen sensor 2                            | <a href="#">EC-50, "Heated Oxygen Sensor 2"</a>                            |
| Heated oxygen sensor 2 heater                     | <a href="#">EC-50, "Heated Oxygen Sensor 2 Heater"</a>                     |
| ICC brake switch                                  | <a href="#">EC-51, "ICC Brake Switch"</a>                                  |
| ICC steering switch                               | <a href="#">EC-52, "ICC Steering Switch"</a>                               |
| Ignition signal                                   | <a href="#">EC-51, "Ignition Coil"</a>                                     |
| Intake air temperature sensor                     | <a href="#">EC-51, "Intake Air Temperature Sensor"</a>                     |
| Intake valve timing control solenoid valve        | <a href="#">EC-51, "Intake Valve Timing Control Solenoid Valve"</a>        |
| Knock sensor                                      | <a href="#">EC-52, "Knock Sensor"</a>                                      |
| Manifold absolute pressure (MAP) sensor           | <a href="#">EC-52, "Manifold Absolute Pressure Sensor"</a>                 |
| Mass air flow sensor                              | <a href="#">EC-52, "Mass Air Flow Sensor"</a>                              |
| PCV valve   | <a href="#">EC-55, "Positive Crankcase Ventilation"</a>                    |
| Power steering pressure sensor                    | <a href="#">EC-52, "Power Steering Pressure Sensor"</a>                    |
| Refrigerant pressure sensor                       | <a href="#">EC-53, "Refrigerant Pressure Sensor"</a>                       |
| Stop lamp switch                                  | <a href="#">EC-46, "Brake Switch"</a>                                      |
| Throttle control motor                            | <a href="#">EC-53, "Throttle Control Motor"</a>                            |
| Throttle control motor relay                      | <a href="#">EC-53, "Throttle Control Motor Relay"</a>                      |
| Throttle position sensor                          | <a href="#">EC-53, "Throttle Position Sensor"</a>                          |
| VVEL actuator motor                               | <a href="#">EC-53, "VVEL Actuator Motor"</a>                               |
| VVEL actuator motor relay                         | <a href="#">EC-53, "VVEL Actuator Motor Relay"</a>                         |
| VVEL control module                               | <a href="#">EC-54, "VVEL Control Module"</a>                               |
| VVEL control shaft position sensor                | <a href="#">EC-54, "VVEL Control Position Sensor"</a>                      |

### Infiniti Drive Mode Selector

# COMPONENT PARTS

< SYSTEM DESCRIPTION >

[VQ37VHR FOR USA AND CANADA]

## Infiniti Drive Mode Selector : Component Parts Location

INFOID:000000006882738

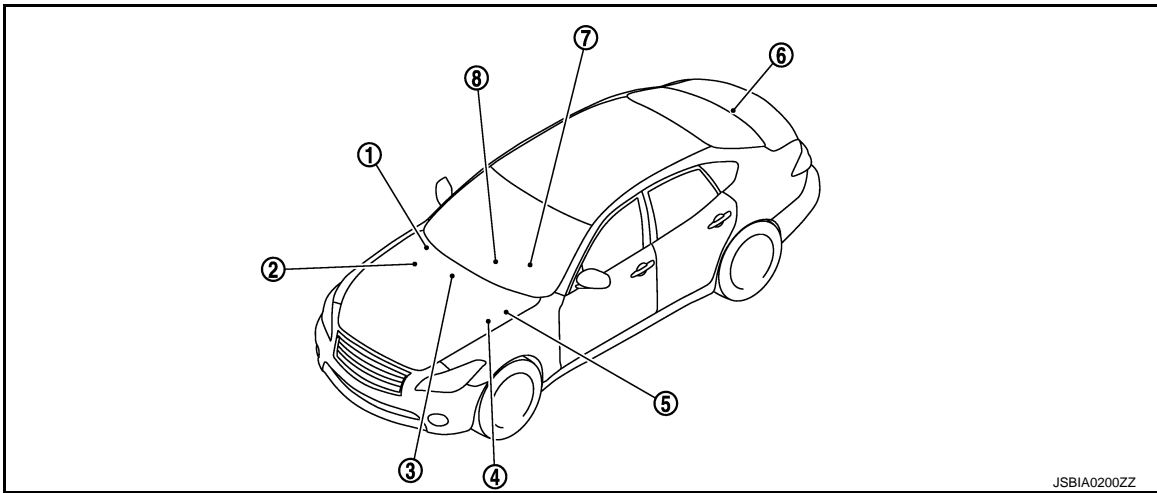

1. A/C auto amp.  
Refer to [HAC-7, "AUTOMATIC AIR CONDITIONING SYSTEM \(WITH FOREST AIR\) : Component Parts Location"](#) (WITH FOREST AIR).  
Refer to [HAC-10, "AUTOMATIC AIR CONDITIONING SYSTEM \(WITHOUT FOREST AIR\) : Component Parts Location"](#) (WITHOUT FOREST AIR).
2. ECM  
Refer to [EC-38, "ENGINE CONTROL SYSTEM : Component Parts Location"](#).
3. AV control unit  
Refer to [AV-10, "Component Parts Location"](#) (BASE AUDIO WITHOUT NAVIGATION).  
Refer to [AV-127, "Component Parts Location"](#) (BOSE AUDIO WITH NAVIGATION).
4. Accelerator pedal actuator
5. Combination meter  
(Vehicle information display, and ECO drive indicator)
6. ADAS control unit  
[DAS-14, "Component Parts Location"](#).
7. TCM  
[TM-10, "A/T CONTROL SYSTEM : Component Parts Location"](#).
8. Drive mode select switch

## Infiniti Drive Mode Selector : Component Description

INFOID:000000006882739

| Part name                | Description   |
|--------------------------|---|
| Drive mode select switch | Transmits an ON/OFF state signal of STANDARD, SPORT, ECO, or SNOW mode to the A/C auto amp.   |
| A/C auto amp.            | Transmits an input signal (ON/OFF state of each mode) received from the drive mode select switch to the TCM, combination meter, 4WAS main control unit, and ADAS control unit via CAN communication.  |
| AV control unit          | Transmits an ECO pedal* reaction force setting signal (Standard/Soft/OFF) to ECM via CAN communication. This signal determines reaction force of the accelerator pedal.   |
| TCM                      | Transmits a state of a mode received from the A/C auto amp. to ECM.   |
| ECM                      | <ul style="list-style-type: none"> <li>• Receives a ECO mode signal from TCM and controls throttle angle characteristics and torque.</li> <li>• Determines reaction force in accordance with the accelerator pedal operation when in ECO mode and transmits an ECO pedal* reaction force control signal to the ADAS control unit. When receiving the ECO pedal* reaction force setting signal (Standard/Soft/OFF) from the AV control unit, ECM updates ECO pedal* reaction force. Furthermore, ECM sends back the received signal to the AV control unit for confirmation.</li> <li>• Controls the ECO drive indicator when in ECO mode. The ECO drive indicator turns ON or blinks (with ECO pedal*) according to accelerator pedal operation.</li> </ul> |
| Combination meter        | <ul style="list-style-type: none"> <li>• Indicates a mode state on the vehicle information display, based on a mode state signal received from the A/C auto amp.</li> <li>• Turns ON or blinks (with ECO pedal*) the ECO drive indicator according to a request from ECM when in ECO mode.</li> </ul>   |

# COMPONENT PARTS

< SYSTEM DESCRIPTION >

[VQ37VHR FOR USA AND CANADA]

| Part name                  | Description   |
|----------------------------|---|
| ADAS control unit          | Controls accelerator pedal reaction force of the accelerator pedal actuator when in ECO mode, based on an ECO pedal* reaction force control signal received from ECM. |
| Accelerator pedal actuator | Applies reaction force to the accelerator pedal when in ECO mode, based on an accelerator pedal reaction force control signal received from the ADAS control unit.    |

\*: ECO pedal control is only for vehicles with intelligent pedal (distance control assist).

## Accelerator Pedal Position Sensor

INFOID:000000006882740

The accelerator pedal position sensor is installed on the upper end of the accelerator pedal assembly. The sensor detects the accelerator pedal position and sends a signal to the ECM.

Accelerator pedal position sensor has two sensors. These sensors are a kind of potentiometer which transform the accelerator pedal position into output voltage, and emit the voltage signal to the ECM. The ECM judges the current opening angle of the accelerator pedal from these signals and controls the throttle control motor based on these signals.

Idle position of the accelerator pedal is determined by the ECM receiving the signal from the accelerator pedal position sensor. The ECM uses this signal for engine operations such as fuel cut.

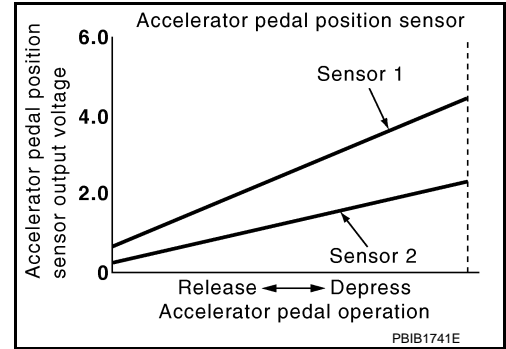

## Air Fuel Ratio Sensor 1

INFOID:000000006882741

The air fuel ratio (A/F) sensor 1 is a planar one-cell limit current sensor. The sensor element of the A/F sensor 1 is composed an electrode layer, which transports ions. It has a heater in the element.

The sensor is capable of precise measurement  $\lambda = 1$ , but also in the lean and rich range. Together with its control electronics, the sensor outputs a clear, continuous signal throughout a wide  $\lambda$  range.

The exhaust gas components diffuse through the diffusion layer at the sensor cell. An electrode layer is applied voltage, and this current relative oxygen density in lean. Also this current relative hydrocarbon density in rich.

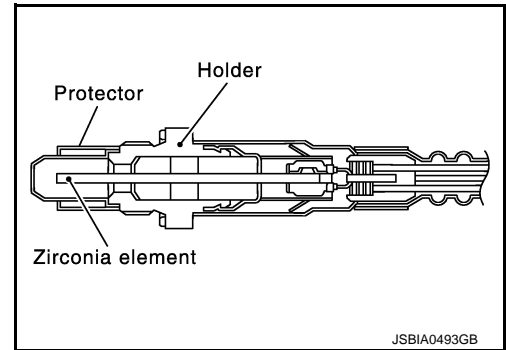

Therefore, the A/F sensor 1 is able to indicate air fuel ratio by this electrode layer of current. In addition, a heater is integrated in the sensor to ensure the required operating temperature of about 800°C (1,472°F).

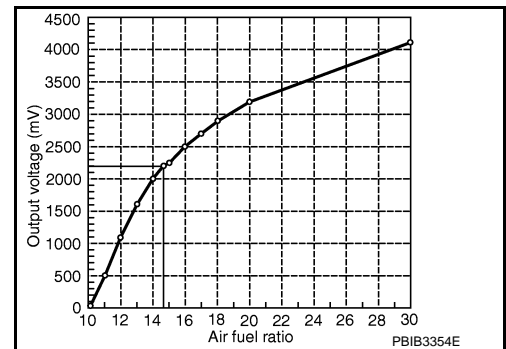

## Air Fuel Ratio Sensor 1 Heater

INFOID:000000006882742

### SYSTEM DESCRIPTION

| Sensor   | Input Signal to ECM  | ECM function                                    | Actuator                                |
|--|----------------------|---|---|
| Camshaft position sensor (PHASE)<br>Crankshaft position sensor (POS) | Engine speed         | Air fuel ratio (A/F) sensor 1<br>heater control | Air fuel ratio (A/F) sensor 1<br>heater |
| Mass air flow sensor   | Amount of intake air |   |   |

The ECM performs ON/OFF duty control of the A/F sensor 1 heater corresponding to the engine operating condition to keep the temperature of A/F sensor 1 element at the specified range.

### ASCD Brake Switch

INFOID:000000006882743

When the brake pedal is depressed, ASCD brake switch is turned OFF and stop lamp switch is turned ON. ECM detects the state of the brake pedal by those two types of input (ON/OFF signal). Refer to [EC-63. "AUTOMATIC SPEED CONTROL DEVICE \(ASCD\) : System Description"](#) for the ASCD function.

### ASCD Indicator

INFOID:000000006882744

ASCD operation status is indicated by two indicators (CRUISE and SET) and CRUISE lamp in combination meter.

CRUISE indicator is displayed to indicated that ASCD system is ready for operation when MAIN switch on ASCD steering switch is turned ON.

SET indicator is displayed when the following conditions are met.

- CRUISE indicator is displayed.
- SET/COAST switch on ASCD steering switch is turned ON while vehicle speed is within the range of the ASCD setting.

SET indicator is displayed during ASCD control.

Refer to [EC-63. "AUTOMATIC SPEED CONTROL DEVICE \(ASCD\) : System Description"](#) for the ASCD function.

### ASCD Steering Switch

INFOID:000000006882745

ASCD steering switch has variant values of electrical resistance for each button. ECM reads voltage variation of switch, and determines which button is operated.

Refer to [EC-63. "AUTOMATIC SPEED CONTROL DEVICE \(ASCD\) : System Description"](#) for the ASCD function.

### Battery Current Sensor (With Battery Temperature Sensor)

INFOID:000000006882746

#### OUTLINE

The power generation voltage variable control enables fuel consumption to be decreased by reducing the engine load which is caused by the power generation of the generator.

Based on sensor signals, ECM judges whether or not the power generation voltage variable control is performed. When performing the power generation voltage variable control, ECM calculates the target power generation voltage based on the sensor signal. And ECM sends the calculated value as the power generation command value to IPDM E/R. For the details of the power generation voltage variable control, refer to [CHG-8. "POWER GENERATION VOLTAGE VARIABLE CONTROL SYSTEM : System Description"](#).

#### CAUTION:

**Never connect the electrical component or the ground wire directly to the battery terminal. The connection causes the malfunction of the power generation voltage variable control, and then the battery discharge may occur.**

#### BATTERY CURRENT SENSOR

The battery current sensor is installed to the battery negative cable. The sensor measures the charging/discharging current of the battery.

#### BATTERY TEMPERATURE SENSOR

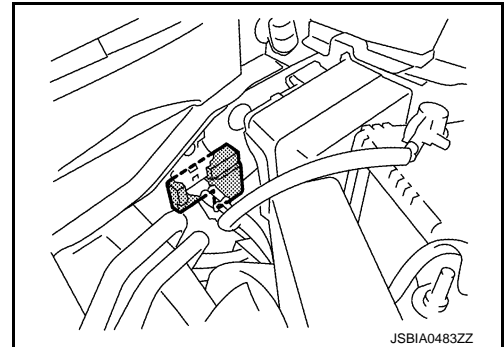

JSBIA0483ZZ

# COMPONENT PARTS

## < SYSTEM DESCRIPTION >

[VQ37VHR FOR USA AND CANADA]

Battery temperature sensor is integrated in battery current sensor. The sensor measures temperature around the battery. The electrical resistance of the thermistor decreases as temperature increases.

### <Reference data>

| Temperature [°C (°F)] | Voltage* (V) | Resistance (kΩ) |
|-----------------------|--------------|-----------------|
| 25 (77)               | 3.333        | 1.9 - 2.1       |
| 90 (194)              | 0.969        | 0.222 - 0.258   |

\*: These data are reference values and are measured between battery temperature sensor signal terminal and sensor ground.

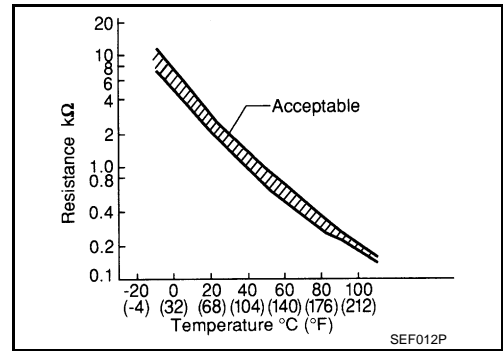

## Brake Switch

INFOID:000000006882747

Brake switch signal is applied to the ECM through the stop lamp switch when the brake pedal is depressed. This signal is used mainly to decrease the engine speed when the vehicle is being driven.

## Camshaft Position Sensor (PHASE)

INFOID:000000006882748

The camshaft position sensor (PHASE) senses the retraction of camshaft (INT) to identify a particular cylinder. The camshaft position sensor (PHASE) senses the piston position.

When the crankshaft position sensor (POS) system becomes inoperative, the camshaft position sensor (PHASE) provides various controls of engine parts instead, utilizing timing of cylinder identification signals.

The sensor consists of a permanent magnet and Hall IC.

When engine is running, the high and low parts of the teeth cause the gap with the sensor to change.

The changing gap causes the magnetic field near the sensor to change.

Due to the changing magnetic field, the voltage from the sensor changes.

ECM receives the signals as shown in the figure.

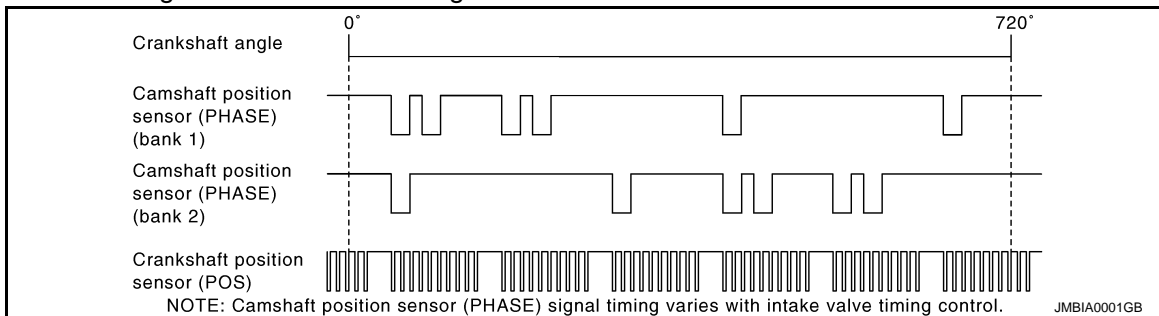
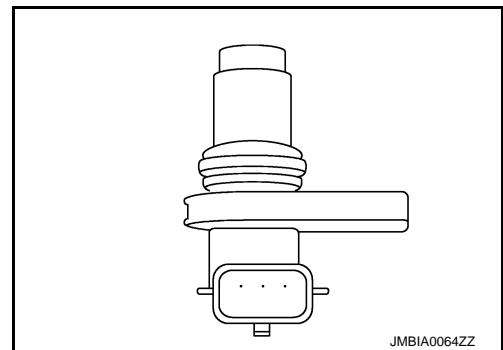

## Cooling Fan

INFOID:000000006882749

### COOLING FAN CONTROL MODULE

Cooling fan control module receives ON/OFF pulse duty signal from IPDM E/R. Corresponding to this ON/OFF pulse duty signal, cooling fan control module sends cooling fan motor operating voltage to cooling fan motor. The revolution speed of cooling fan motor is controlled by duty cycle of the voltage.

### COOLING FAN MOTOR

Cooling fan motor receives cooling fan motor operating voltage from cooling fan control module. The revolution speed of cooling fan motor is controlled by duty cycle of the voltage.

# COMPONENT PARTS

< SYSTEM DESCRIPTION >

[VQ37VHR FOR USA AND CANADA]

## Crankshaft Position Sensor (POS)

INFOID:000000006882751

The crankshaft position sensor (POS) is located on the cylinder block facing the gear teeth (cogs) of the signal plate. It detects the fluctuation of the engine revolution.

The sensor consists of a permanent magnet and Hall IC.

When the engine is running, the high and low parts of the teeth cause the gap with the sensor to change.

The changing gap causes the magnetic field near the sensor to change.

Due to the changing magnetic field, the voltage from the sensor changes.

The ECM receives the voltage signal and detects the fluctuation of the engine revolution.

ECM receives the signals as shown in the figure.

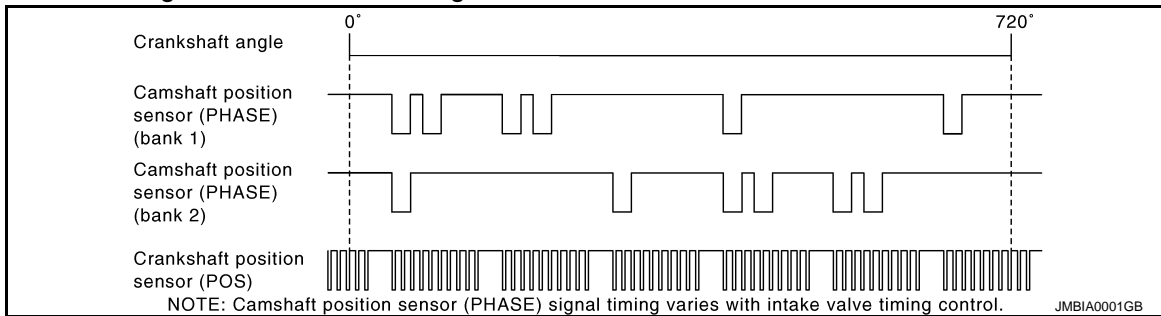
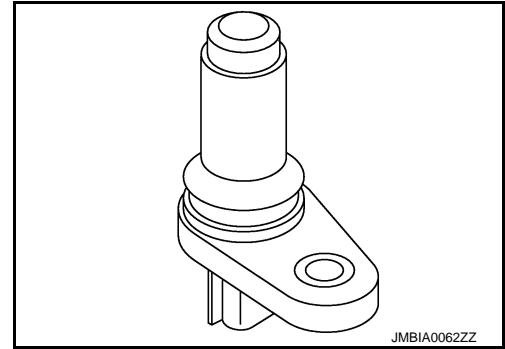

## ECM

INFOID:000000006882751

The ECM consists of a microcomputer and connectors for signal input and output and for power supply. The ECM controls the engine.

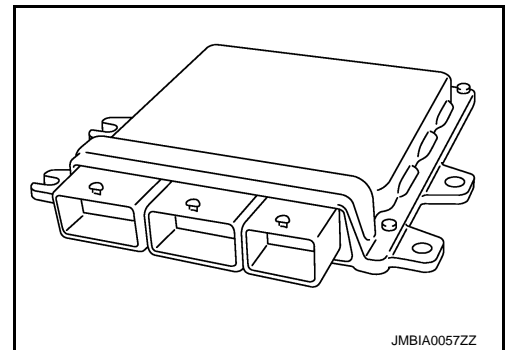

## Electric Throttle Control Actuator

INFOID:000000006882752

Electric throttle control actuator consists of throttle control motor, throttle position sensor, etc.

The throttle control motor is operated by the ECM and it opens and closes the throttle valve.

The throttle position sensor detects the throttle valve position and feeds the voltage signals to the ECM. The ECM judges the current opening angle of the throttle valve from these signals and controls the throttle valve opening angle properly in response to driving condition via the throttle control motor.

## Engine Coolant Temperature Sensor

INFOID:000000006882753

The engine coolant temperature sensor is used to detect the engine coolant temperature. The sensor modifies a voltage signal from the ECM. The modified signal returns to the ECM as the engine coolant temperature input. The sensor uses a thermistor which is sensitive to the change in temperature. The electrical resistance of the thermistor decreases as temperature increases.

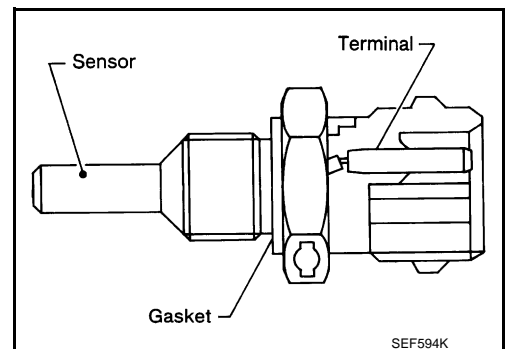

A  
EC  
C  
D  
E  
F  
G  
H  
I  
J  
K  
L  
M  
N  
O  
P

# COMPONENT PARTS

< SYSTEM DESCRIPTION >

[VQ37VHR FOR USA AND CANADA]

## <Reference data>

| Engine coolant temperature [°C (°F)] | Voltage* (V) | Resistance (kΩ) |
|--------------------------------------|--------------|-----------------|
| -10 (14)                             | 4.4          | 7.0 - 11.4      |
| 20 (68)                              | 3.5          | 2.10 - 2.90     |
| 50 (122)                             | 2.2          | 0.68 - 1.00     |
| 90 (194)                             | 0.9          | 0.236 - 0.260   |

\*: These data are reference values and are measured between ECM terminals 71 (Engine coolant temperature sensor) and 84 (Sensor ground).

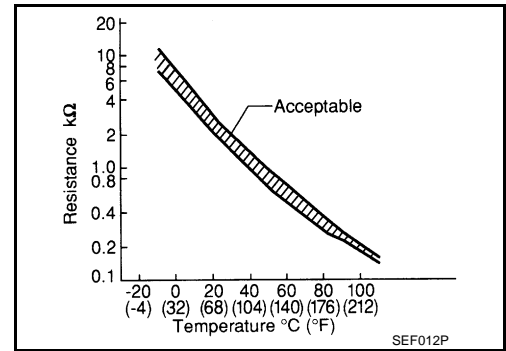

## Engine Oil Temperature Sensor

The engine oil temperature sensor is used to detect the engine oil temperature. The sensor modifies a voltage signal from the ECM. The modified signal returns to the ECM as the engine oil temperature input. The sensor uses a thermistor which is sensitive to the change in temperature. The electrical resistance of the thermistor decreases as temperature increases.

INFOID:000000006882754

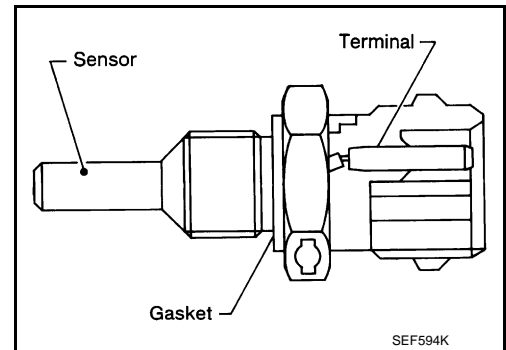

## <Reference data>

| Engine oil temperature [°C (°F)] | Voltage* (V) | Resistance (kΩ) |
|----------------------------------|--------------|-----------------|
| -10 (14)                         | 4.4          | 7.0 - 11.4      |
| 20 (68)                          | 3.5          | 2.10 - 2.90     |
| 50 (122)                         | 2.2          | 0.68 - 1.00     |
| 90 (194)                         | 0.9          | 0.236 - 0.260   |
| 110 (230)                        | 0.6          | 0.143 - 0.153   |

\*: These data are reference values and are measured between ECM terminals 78 (Engine oil temperature sensor) and 84 (Sensor ground).

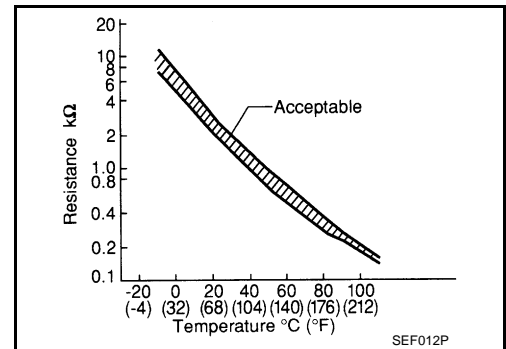

## EVAP Canister Purge Volume Control Solenoid Valve

The EVAP canister purge volume control solenoid valve is used to control the flow rate of fuel vapor from the EVAP canister. The EVAP canister purge volume control solenoid valve is moved by ON/OFF pulses from the ECM. The longer the ON pulse, the greater the amount of fuel vapor that will flow through the valve.

INFOID:000000006882755

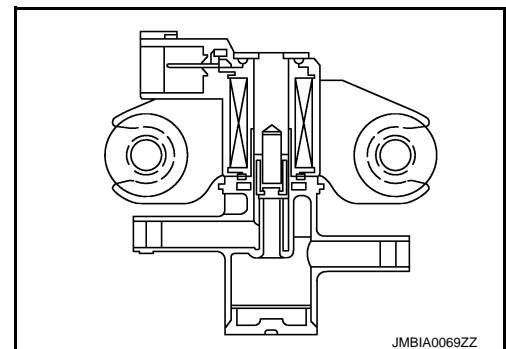



# COMPONENT PARTS

< SYSTEM DESCRIPTION >

[VQ37VHR FOR USA AND CANADA]

## EVAP Canister Vent Control Valve

INFOID:000000006882758

The EVAP canister vent control valve is located on the EVAP canister and is used to seal the canister vent.

This solenoid valve responds to signals from the ECM. When the ECM sends an ON signal, the coil in the solenoid valve is energized. A plunger will then move to seal the canister vent. The ability to seal the vent is necessary for the on board diagnosis of other evaporative emission control system components.

This solenoid valve is used only for diagnosis, and usually remains opened.

When the vent is closed, under normal purge conditions, the evaporative emission control system is depressurized and allows "EVAP Control System" diagnosis.

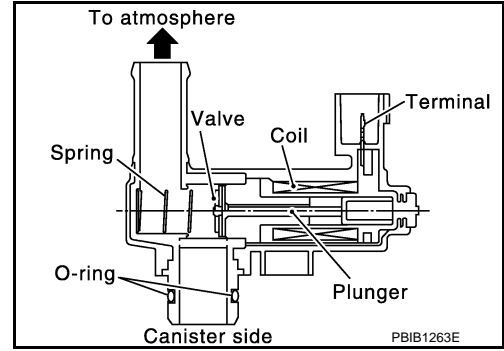

## EVAP Control System Pressure Sensor

INFOID:000000006882757

The EVAP control system pressure sensor detects pressure in the purge line. The sensor output voltage to the ECM increases as pressure increases.

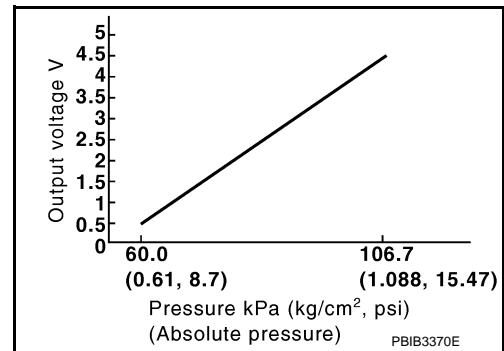

## Fuel Injector

INFOID:000000006882759

The fuel injector is a small, precise solenoid valve. When the ECM supplies a ground to the fuel injector circuit, the coil in the fuel injector is energized. The energized coil pulls the ball valve back and allows fuel to flow through the fuel injector into the intake manifold. The amount of fuel injected depends upon the injection pulse duration. Pulse duration is the length of time the fuel injector remains open. The ECM controls the injection pulse duration based on engine fuel needs.

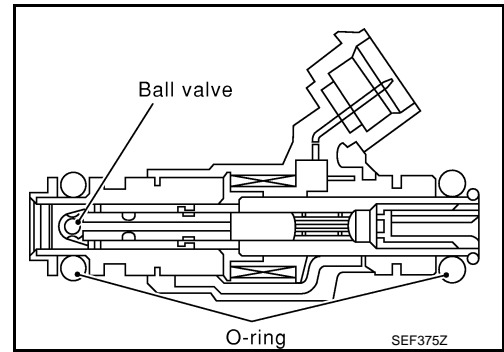

## Fuel Level Sensor

INFOID:000000006882759

The fuel level sensor is mounted in the fuel level sensor unit.

The sensor detects a fuel level in the fuel tank and transmits a signal to the "A/C auto amp.". The "A/C auto amp." sends the fuel level sensor signal to the ECM via the CAN communication line.

It consists of two parts, one is mechanical float and the other is variable resistor. Fuel level sensor output voltage changes depending on the movement of the fuel mechanical float.

## Fuel Pump

INFOID:000000006882760

| Sensor   | Input signal to ECM | ECM Function      | Actuator        |
|--|---------------------|-------------------|-----------------|
| Crankshaft position sensor (POS)<br>Camshaft position sensor (PHASE) | Engine speed*       | Fuel pump control | Fuel pump relay |
| Battery  | Battery voltage*    |                   | ↓<br>Fuel pump  |

\*: ECM determines the start signal status by the signals of engine speed and battery voltage.

The ECM activates the fuel pump for several seconds after the ignition switch is turned ON to improve engine startability. If the ECM receives a engine speed signal from the camshaft position sensor (PHASE), it knows

# COMPONENT PARTS

## < SYSTEM DESCRIPTION >

[VQ37VHR FOR USA AND CANADA]

that the engine is rotating, and causes the pump to operate. If the engine speed signal is not received when the ignition switch is ON, the engine stalls. The ECM stops pump operation and prevents battery discharging, thereby improving safety. The ECM does not directly drive the fuel pump. It controls the ON/OFF fuel pump relay, which in turn controls the fuel pump.

| Condition                        | Fuel pump operation    |
|----------------------------------|------------------------|
| Ignition switch is turned to ON. | Operates for 1 second. |
| Engine running and cranking      | Operates.              |
| When engine is stopped           | Stops in 1.5 seconds.  |
| Except as shown above            | Stops.                 |

## Fuel Tank Temperature Sensor

INFOID:000000006882761

The fuel tank temperature sensor is used to detect the fuel temperature inside the fuel tank. The sensor modifies a voltage signal from the ECM. The modified signal returns to the ECM as the fuel temperature input. The sensor uses a thermistor which is sensitive to the change in temperature. The electrical resistance of the thermistor decreases as temperature increases.

### <Reference data>

| Fluid temperature [°C (°F)] | Voltage* (V) | Resistance (kΩ) |
|-----------------------------|--------------|-----------------|
| 20 (68)                     | 3.5          | 2.3 - 2.7       |
| 50 (122)                    | 2.2          | 0.79 - 0.90     |

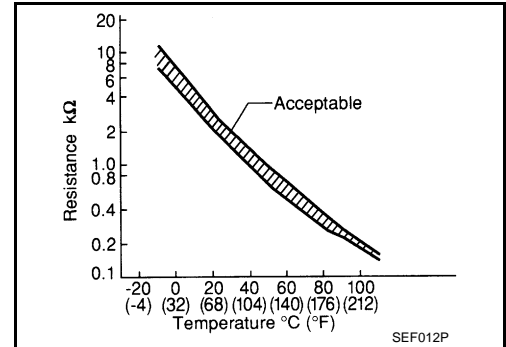

\*: These data are reference values and are measured between ECM terminals 106 (Fuel tank temperature sensor) and 128 (ECM ground).

## Heated Oxygen Sensor 2

INFOID:000000006882762

The heated oxygen sensor 2, after three way catalyst 1, monitors the oxygen level in the exhaust gas on each bank. Even if switching characteristics of the air fuel ratio (A/F) sensor 1 are shifted, the air-fuel ratio is controlled to stoichiometric, by the signal from the heated oxygen sensor 2. This sensor is made of ceramic zirconia. The zirconia generates voltage from approximately 1 V in richer conditions to 0 V in leaner conditions. Under normal conditions the heated oxygen sensor 2 is not used for engine control operation.

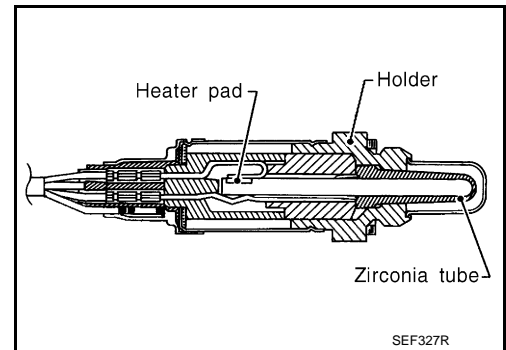

## Heated Oxygen Sensor 2 Heater

INFOID:000000006882763

### SYSTEM DESCRIPTION

| Sensor   | Input signal to ECM        | ECM function                          | Actuator                      |
|--|----------------------------|---------------------------------------|-------------------------------|
| Camshaft position sensor (PHASE)<br>Crankshaft position sensor (POS) | Engine speed               | Heated oxygen sensor 2 heater control | Heated oxygen sensor 2 heater |
| Engine coolant temperature sensor                                    | Engine coolant temperature |                                       |                               |
| Mass air flow sensor   | Amount of intake air       |                                       |                               |

The ECM performs ON/OFF control of the heated oxygen sensor 2 heater corresponding to the engine speed, amount of intake air and engine coolant temperature.

### OPERATION

# COMPONENT PARTS

< SYSTEM DESCRIPTION >

[VQ37VHR FOR USA AND CANADA]

| Engine speed rpm   | Heated oxygen sensor 2 heater |
|--|-------------------------------|
| Above 3,600  | OFF                           |
| Below 3,600 rpm after the following conditions are met. <ul style="list-style-type: none"> <li>• Engine: After warming up</li> <li>• Keeping the engine speed between 3,500 and 4,000 rpm for 1 minute and at idle for 1 minute under no load</li> </ul> | ON                            |

A  
EC

## Ignition Coil

INFOID:000000006882764

The ignition signal from the ECM is sent to and amplified by the power transistor. The power transistor turns ON and OFF the ignition coil primary circuit. This ON/OFF operation induces the proper high voltage in the coil secondary circuit.

## Intake Air Temperature Sensor

INFOID:000000006882765

The intake air temperature sensor is built-into the mass air flow sensor (1). The sensor detects intake air temperature and transmits a signal to the ECM.

The temperature sensing unit uses a thermistor which is sensitive to the change in temperature. Electrical resistance of the thermistor decreases in response to the rise in temperature.

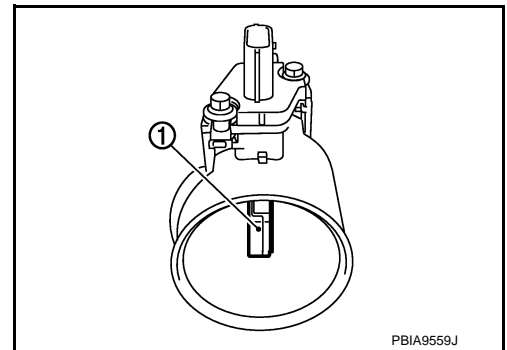

### <Reference data>

| Intake air temperature [°C (°F)] | Voltage* (V) | Resistance (kΩ) |
|----------------------------------|--------------|-----------------|
| 25 (77)                          | 3.3          | 1.800 - 2.200   |
| 80 (176)                         | 1.2          | 0.283 - 0.359   |

\*: These data are reference values and are measured between ECM terminals 67 (Intake air temperature sensor) and 68 (Sensor ground).

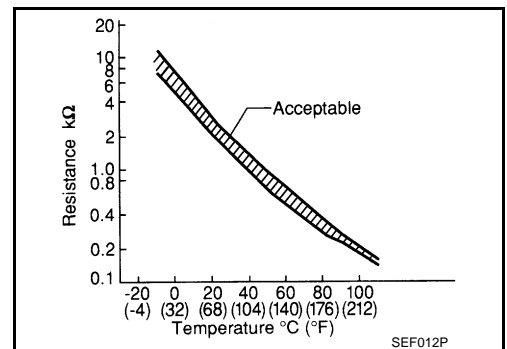

## Intake Valve Timing Control Solenoid Valve

INFOID:000000006882766

Intake valve timing control solenoid valve is activated by ON/OFF pulse duty (ratio) signals from the ECM.

The intake valve timing control solenoid valve changes the oil amount and direction of flow through intake valve timing control unit or stops oil flow.

The longer pulse width advances valve angle.

The shorter pulse width retards valve angle.

When ON and OFF pulse widths become equal, the solenoid valve stops oil pressure flow to fix the intake valve angle at the control position.

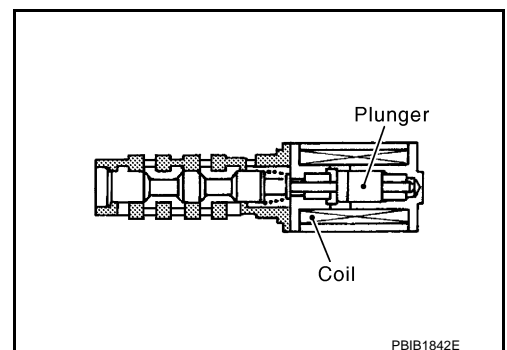

## ICC Brake Switch

INFOID:000000006882767

When the brake pedal is depressed, ICC brake switch is turned OFF and stop lamp switch is turned ON. ECM detects the state of the brake pedal by those two types of input (ON/OFF signal).

Refer to [CCS-13, "System Description"](#) for the ICC function.

C  
D  
E  
F  
G  
H  
I  
J  
K  
L  
M  
N  
O  
P

< SYSTEM DESCRIPTION >

## ICC Steering Switch

INFOID:000000006882768

ICC steering switch has variant values of electrical resistance for each button. ECM reads voltage variation of switch, and determines which button is operated. Refer to [CCS-13, "System Description"](#) for the ICC function.

## Knock Sensor

INFOID:000000006882769

The knock sensor is attached to the cylinder block. It senses engine knocking using a piezoelectric element. A knocking vibration from the cylinder block is sensed as vibrational pressure. This pressure is converted into a voltage signal and sent to the ECM.

## Manifold Absolute Pressure Sensor

INFOID:000000006882770

The manifold absolute pressure (MAP) sensor is placed at intake manifold collector. It detects intake manifold pressure and sends the voltage signal to the ECM.

The sensor uses a silicon diaphragm which is sensitive to the change in pressure. As the pressure increases, the voltage rises.

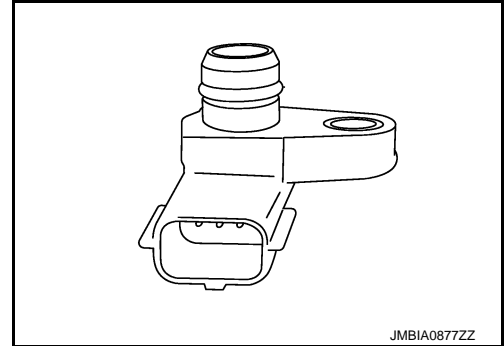

## Malfunction Indicator Lamp

INFOID:000000006882771

The Malfunction Indicator Lamp (MIL) is located on the combination meter.

The MIL will illuminate when the ignition switch is turned ON without the engine running. This is a bulb check.

When the engine is started, the MIL should turn off. If the MIL remains illuminated, the on board diagnostic system has detected an engine system malfunction.

For details, refer to [EC-77, "Diagnosis Description"](#).

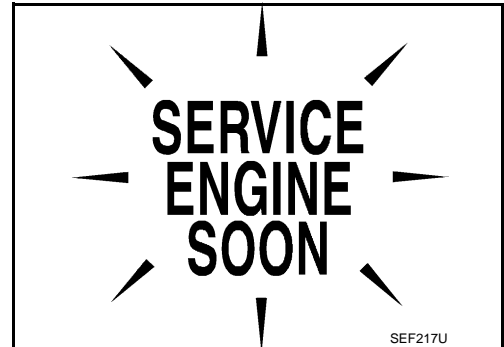

## Mass Air Flow Sensor

INFOID:000000006882772

The mass air flow sensor (1) is placed in the stream of intake air. It measures the intake flow rate by measuring a part of the entire intake flow. The mass air flow sensor controls the temperature of the hot wire to a certain amount. The heat generated by the hot wire is reduced as the intake air flows around it. The greater air flow, the greater the heat loss.

Therefore, the electric current supplied to hot wire is changed to maintain the temperature of the hot wire as air flow increases. The ECM detects the air flow by means of this current change.

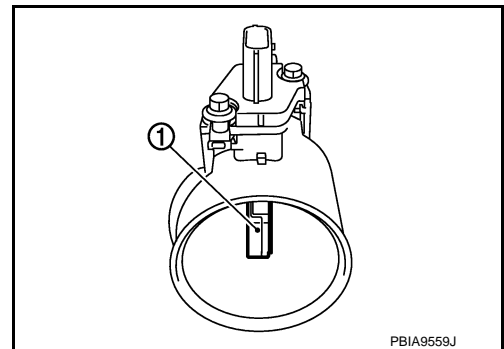

## Power Steering Pressure Sensor

INFOID:000000006882773

Power steering pressure (PSP) sensor is installed to the power steering high-pressure tube and detects a power steering load.

This sensor is a potentiometer which transforms the power steering load into output voltage, and emits the voltage signal to the ECM. The ECM controls the electric throttle control actuator and adjusts the throttle valve opening angle to increase the engine speed and adjusts the idle speed for the increased load.

# COMPONENT PARTS

< SYSTEM DESCRIPTION >

[VQ37VHR FOR USA AND CANADA]

## Refrigerant Pressure Sensor

INFOID:000000006882774

The refrigerant pressure sensor is installed at the condenser of the air conditioner system. The sensor uses an electrostatic volume pressure transducer to convert refrigerant pressure to voltage. The voltage signal is sent to ECM, and ECM controls cooling fan system.

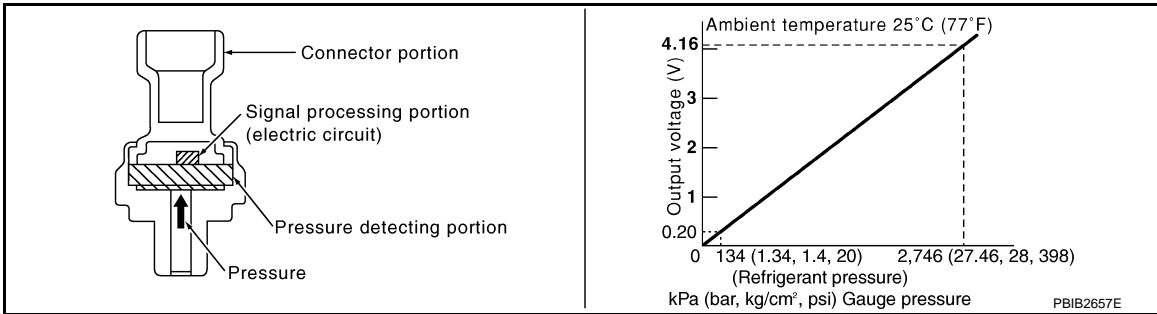

## Throttle Control Motor

INFOID:000000006882775

The throttle control motor is operated by the ECM and it opens and closes the throttle valve. The current opening angle of the throttle valve is detected by the throttle position sensor and it provides feedback to the ECM to control the throttle control motor to make the throttle valve opening angle properly in response to driving condition.

## Throttle Control Motor Relay

INFOID:000000006882776

Power supply for the throttle control motor is provided to the ECM via throttle control motor relay. The throttle control motor relay is ON/OFF controlled by the ECM. When the ignition switch is turned ON, the ECM sends an ON signal to throttle control motor relay and battery voltage is provided to the ECM. When the ignition switch is turned OFF, the ECM sends an OFF signal to throttle control motor relay and battery voltage is not provided to the ECM.

## Throttle Position Sensor

INFOID:000000006882777

Electric throttle control actuator consists of throttle control motor, throttle position sensor, etc. The throttle position sensor responds to the throttle valve movement.

The throttle position sensor has two sensors. These sensors are a kind of potentiometer which transform the throttle valve position into output voltage, and emit the voltage signals to the ECM. The ECM judges the current opening angle of the throttle valve from these signals and controls the throttle valve opening angle properly in response to driving condition via the throttle control motor.

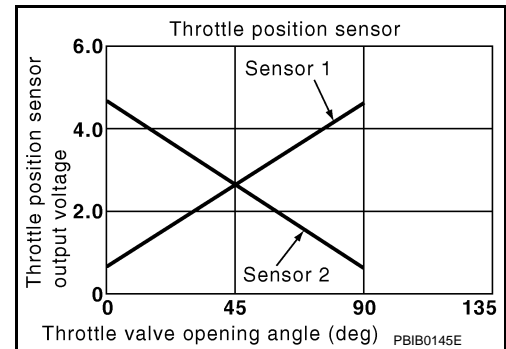

## VVEL Actuator Motor

INFOID:000000006882778

The VVEL actuator motor rotates the control shaft according to the control signal from the VVEL control module. The VVEL control module judges whether the VVEL actuator motor controls the angle properly by the VVEL control shaft position sensor signal.

## VVEL Actuator Motor Relay

INFOID:000000006882779

Power supply for the VVEL actuator motor is provided to the VVEL control module via VVEL actuator motor relay. VVEL actuator motor relay is ON/OFF controlled by the VVEL control module. In addition, when the VVEL actuator motor relay cannot be controlled by the VVEL control module for some reason, it ON/OFF controlled by ECM.

< SYSTEM DESCRIPTION >

### VVEL Control Module

INFOID:000000006882780

The VVEL control module consists of a microcomputer and connectors for signal input and output and for power supply. The VVEL control module controls VVEL system.

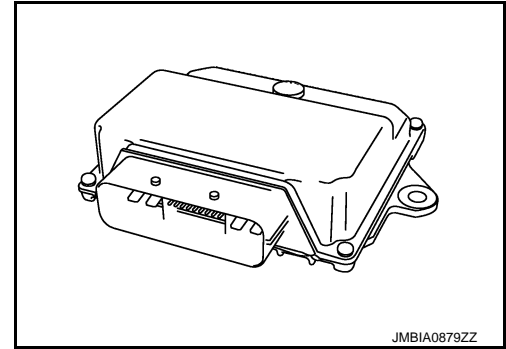

### VVEL Control Position Sensor

INFOID:000000006882781

VVEL control shaft position sensor (1) is placed on VVEL actuator sub assembly and detects the control shaft position angle. A magnet is pressed into the arm on the edge of control shaft. The magnetic field changes as the magnet rotates together with the arm resulting in the output voltage change of the sensor. VVEL control module detects the actual position angle through the voltage change and sends the signal to ECM.

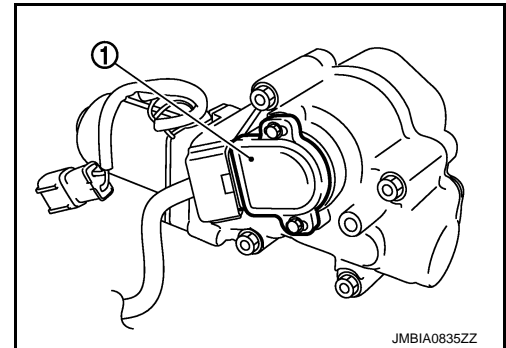

# STRUCTURE AND OPERATION

< SYSTEM DESCRIPTION >

[VQ37VHR FOR USA AND CANADA]

## STRUCTURE AND OPERATION

### Positive Crankcase Ventilation

INFOID:000000006882782

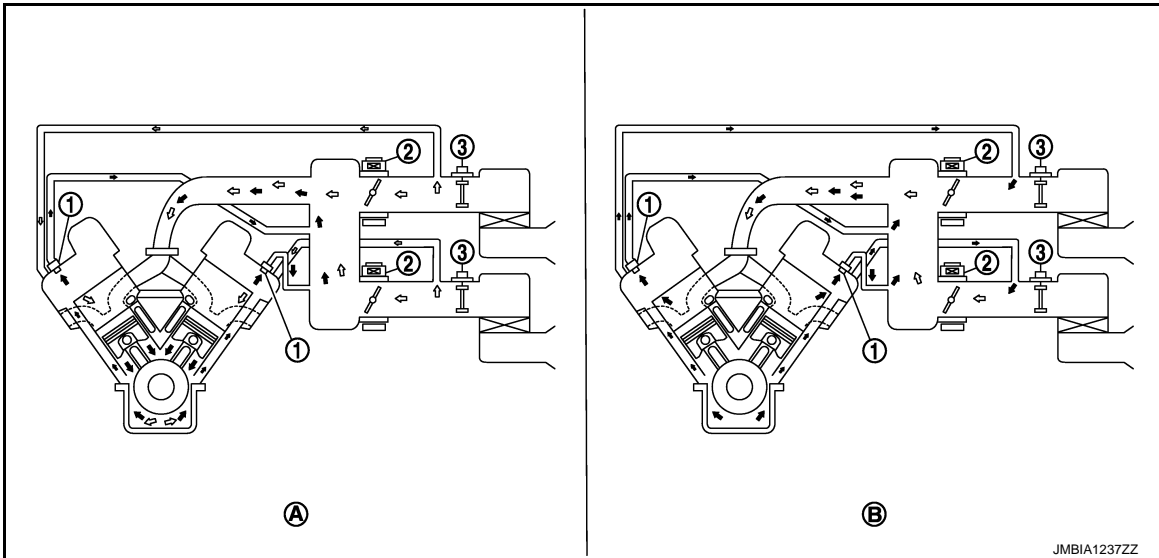

- 1. PCV valve
  - 2. Electric throttle control actuator
  - 3. Mass air flow sensor
- A. Normal condition      B. Hi-load condition

⇐: Fresh air  
 ←: Blow-by air

This system returns blow-by gas to the intake manifold.

The positive crankcase ventilation (PCV) valve is provided to conduct crankcase blow-by gas to the intake manifold.

During partial throttle operation of the engine, the intake manifold sucks the blow-by gas through the PCV valve.

Normally, the capacity of the valve is sufficient to handle any blow-by and a small amount of ventilating air. The ventilating air is drawn from the air inlet tubes into the crankcase. In this process the air passes through the hose connecting air inlet tubes to rocker cover.

Under full-throttle condition, the manifold vacuum is insufficient to draw the blow-by flow through the valve. The flow goes through the hose connection in the reverse direction.

On vehicles with an excessively high blow-by, the valve does not meet the requirement. This is because some of the flow will go through the hose connection to the air inlet tubes under all conditions.

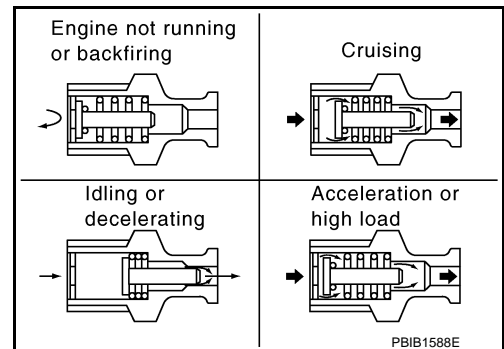

# STRUCTURE AND OPERATION

< SYSTEM DESCRIPTION >

[VQ37VHR FOR USA AND CANADA]

## On Board Refueling Vapor Recovery (ORVR)

INFOID:000000006882783

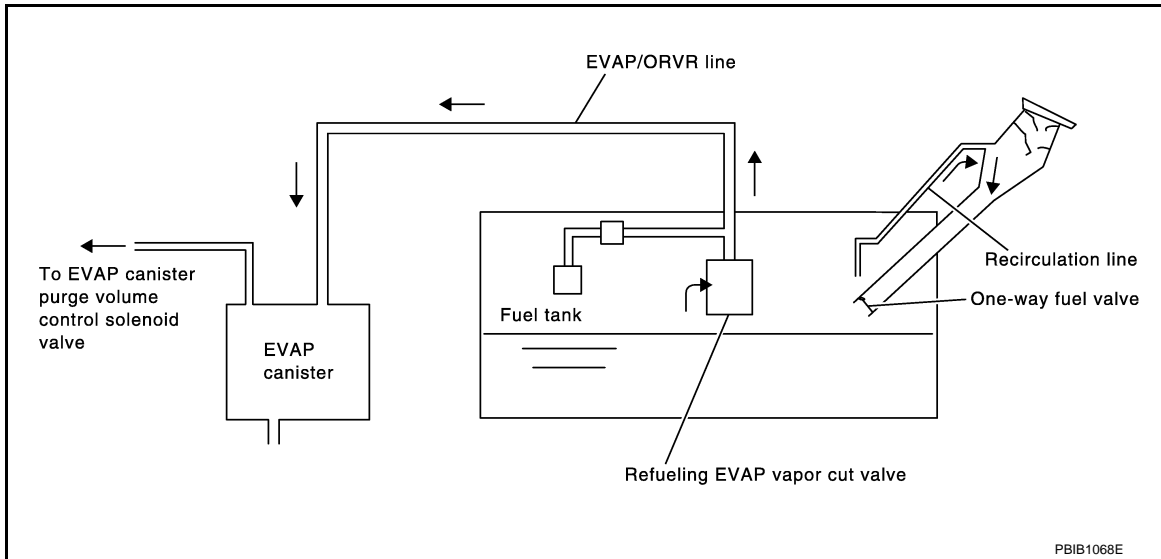

From the beginning of refueling, the air and vapor inside the fuel tank go through refueling EVAP vapor cut valve and EVAP/ORVR line to the EVAP canister. The vapor is absorbed by the EVAP canister and the air is released to the atmosphere.

When the refueling has reached the full level of the fuel tank, the refueling EVAP vapor cut valve is closed and refueling is stopped because of auto shut-off. The vapor which was absorbed by the EVAP canister is purged during driving.

### **WARNING:**

When conducting inspections below, be sure to observe the following:

- Put a “CAUTION: FLAMMABLE” sign in workshop.
- Never smoke while servicing fuel system. Keep open flames and sparks away from work area.
- Always furnish the workshop with a CO<sub>2</sub> fire extinguisher.

### **CAUTION:**

- Before removing fuel line parts, carry out the following procedures:
  - Put drained fuel in an explosion-proof container and put lid on securely.
  - Release fuel pressure from fuel line. Refer to [EC-158. "Work Procedure"](#).
  - Disconnect battery ground cable.
- Always replace O-ring when the fuel gauge retainer is removed.
- Never kink or twist hose and tube when they are installed.
- Never tighten hose and clamps excessively to avoid damaging hoses.
- After installation, run engine and check for fuel leaks at connections.
- Never attempt to top off the fuel tank after the fuel pump nozzle shuts off automatically. Continued refueling may cause fuel overflow, resulting in fuel spray and possibly a fire.



## SYSTEM ENGINE CONTROL SYSTEM

### ENGINE CONTROL SYSTEM : System Diagram

INFOID:000000006882784

A

EC

C

D

E

F

G

H

I

J

K

L

M

N

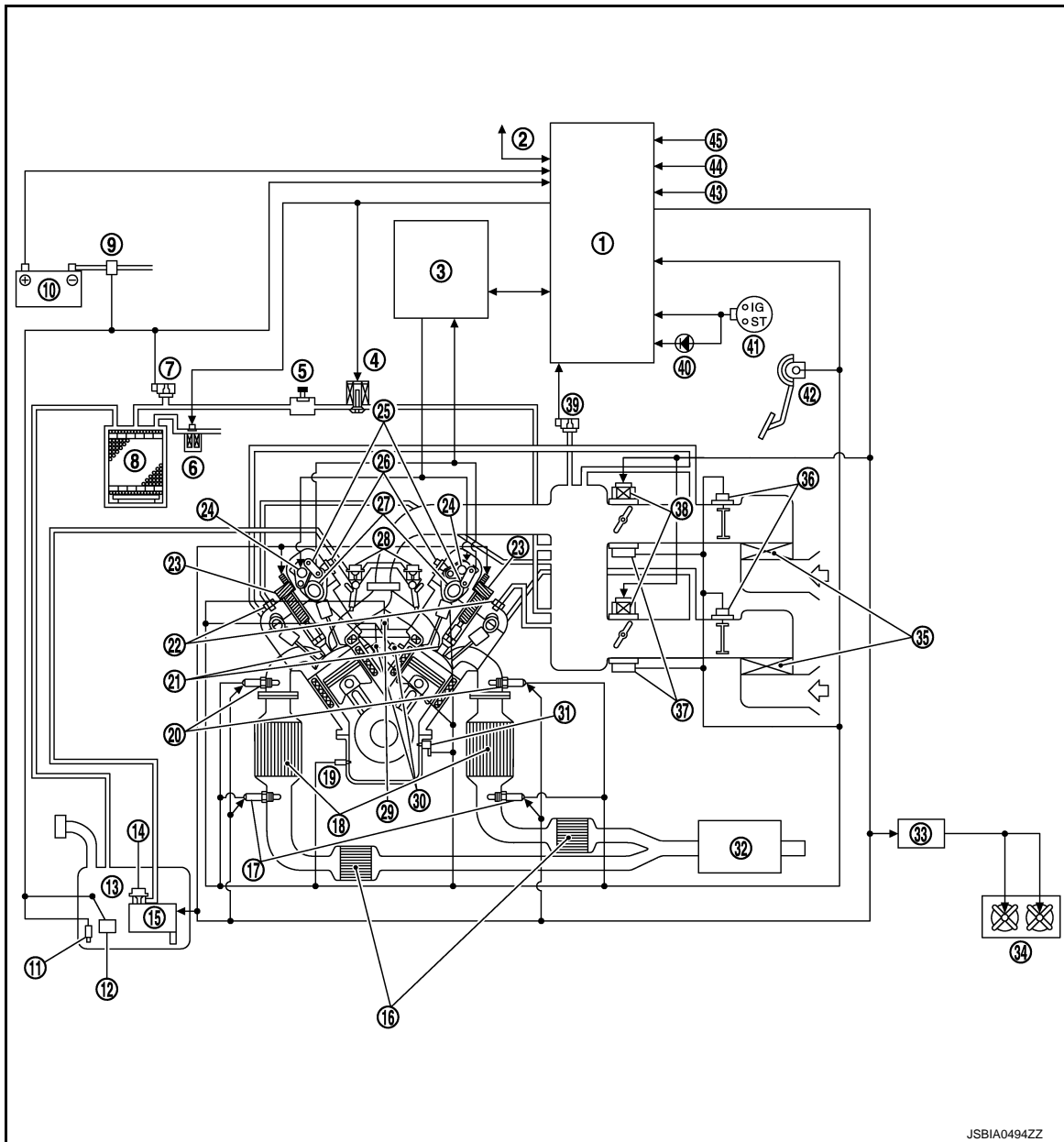

JSBIA0494ZZ

- |  |  |   |
|--|--|---|
| 1. ECM   | 2. Can communication                           | 3. VVEL control module                                      |
| 4. EVAP canister purge volume control solenoid valve | 5. EVAP service port                           | 6. EVAP canister vent control valve                         |
| 7. EVAP control system pressure sensor               | 8. EVAP canister                               | 9. Battery current sensor (with Battery temperature sensor) |
| 10. Battery  | 11. Fuel tank temperature sensor               | 12. Fuel level sensor                                       |
| 13. Fuel tank  | 14. Fuel pressure regulator                    | 15. Fuel pump   |
| 16. Three way catalyst 2                             | 17. Heated oxygen sensor 2                     | 18. Three way catalyst 1                                    |
| 19. Engine oil temperature sensor                    | 20. A/F sensor 1                               | 21. Spark plug  |
| 22. PCV valve  | 23. Ignition coil (with power transistor)      | 24. VVEL actuator motor                                     |
| 25. VVEL control shaft position sensor               | 26. Intake valve timing control solenoid valve | 27. Camshaft position sensor (PHASE)                        |

O

P

# SYSTEM

## < SYSTEM DESCRIPTION >

[VQ37VHR FOR USA AND CANADA]

- |  |                                       |   |
|--|---------------------------------------|---|
| 28. Fuel damper                        | 29. Engine coolant temperature sensor | 30. Knock sensor  |
| 31. Crankshaft position sensor (POS)   | 32. Muffler                           | 33. Cooling fan control module                                |
| 34. Cooling fan                        | 35. Air cleaner                       | 36. Mass air flow sensor (with intake air temperature sensor) |
| 37. Electric throttle control actuator | 38. Throttle position sensor          | 39. Manifold absolute pressure (MAP) sensor                   |
| 40. MIL                                | 41. Ignition switch                   | 42. Accelerator pedal position sensor                         |
| 43. Power steering pressure sensor     | 44. Refrigerant pressure sensor       | 45. PNP signal  |

## ENGINE CONTROL SYSTEM : System Description

INFOID:000000006882785

ECM performs various controls such as fuel injection control and ignition timing control.

## MULTIPOINT FUEL INJECTION SYSTEM

## MULTIPOINT FUEL INJECTION SYSTEM : System Diagram

INFOID:000000006882786

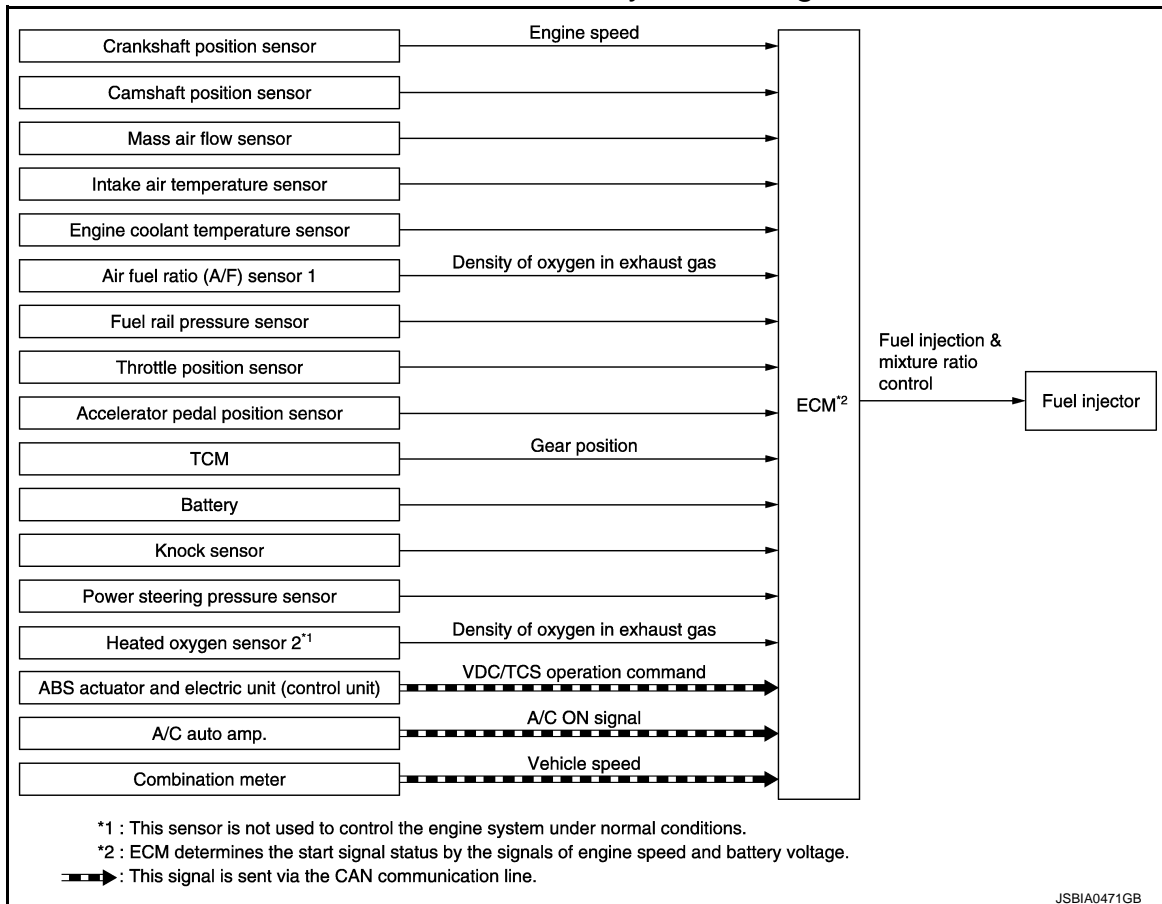

JSBIA0471GB

## MULTIPOINT FUEL INJECTION SYSTEM : System Description

INFOID:000000006882787

## INPUT/OUTPUT SIGNAL CHART

# SYSTEM

< SYSTEM DESCRIPTION >

[VQ37VHR FOR USA AND CANADA]

| Sensor  | Input Signal to ECM               | ECM function                                 | Actuator      |
|---|-----------------------------------|--|---------------|
| Crankshaft position sensor (POS)                | Engine speed*3<br>Piston position | Fuel injection<br>& mixture ratio<br>control | Fuel injector |
| Camshaft position sensor (PHASE)                |                                   |  |               |
| Mass air flow sensor                            | Amount of intake air              |  |               |
| Intake air temperature sensor                   | Intake air temperature            |  |               |
| Engine coolant temperature sensor               | Engine coolant temperature        |  |               |
| Air fuel ratio (A/F) sensor 1                   | Density of oxygen in exhaust gas  |  |               |
| Throttle position sensor                        | Throttle position                 |  |               |
| Accelerator pedal position sensor               | Accelerator pedal position        |  |               |
| TCM   | Gear position                     |  |               |
| Battery   | Battery voltage*3                 |  |               |
| Knock sensor                                    | Engine knocking condition         |  |               |
| Power steering pressure sensor                  | Power steering operation          |  |               |
| Heated oxygen sensor 2*1                        | Density of oxygen in exhaust gas  |  |               |
| ABS actuator and electric unit (control unit)*2 | VDC/TCS operation command         |  |               |
| A/C auto amp.                                   | A/C ON signal*2                   |  |               |
| Combination meter                               | Vehicle speed*2                   |  |               |

\*1: This sensor is not used to control the engine system under normal conditions.

\*2: This signal is sent to the ECM via the CAN communication line.

\*3: ECM determines the start signal status by the signals of engine speed and battery voltage.

## SYSTEM DESCRIPTION

The amount of fuel injected from the fuel injector is determined by the ECM. The ECM controls the length of time the valve remains open (injection pulse duration). The amount of fuel injected is a program value in the ECM memory. The program value is preset by engine operating conditions. These conditions are determined by input signals (for engine speed and intake air) from the crankshaft position sensor (POS), camshaft position sensor (PHASE) and the mass air flow sensor.

## VARIOUS FUEL INJECTION INCREASE/DECREASE COMPENSATION

In addition, the amount of fuel injected is compensated to improve engine performance under various operating conditions as listed below.

<Fuel increase>

- During warm-up
- When starting the engine
- During acceleration
- Hot-engine operation
- When selector lever is changed from N to D
- High-load, high-speed operation

<Fuel decrease>

- During deceleration
- During high engine speed operation

## MIXTURE RATIO FEEDBACK CONTROL (CLOSED LOOP CONTROL)

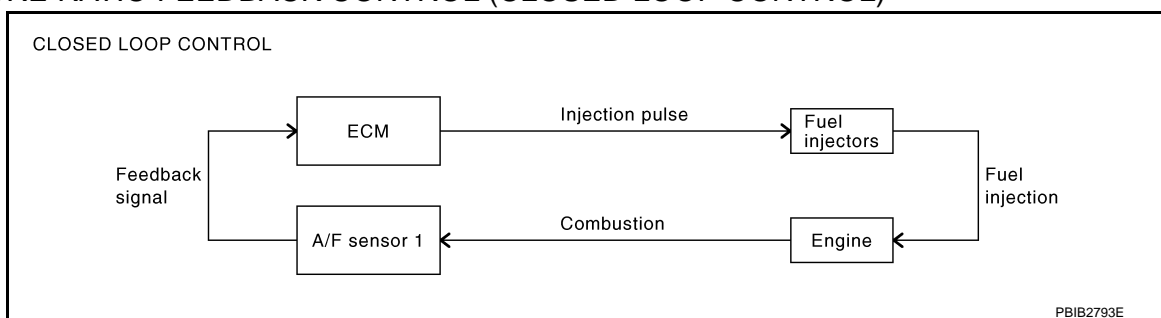

# SYSTEM

## < SYSTEM DESCRIPTION >

[VQ37VHR FOR USA AND CANADA]

The mixture ratio feedback system provides the best air-fuel mixture ratio for driveability and emission control. The three way catalyst 1 can better reduce CO, HC and NOx emissions. This system uses A/F sensor 1 in the exhaust manifold to monitor whether the engine operation is rich or lean. The ECM adjusts the injection pulse width according to the sensor voltage signal. For more information about A/F sensor 1, refer to [EC-44, "Air Fuel Ratio Sensor 1"](#). This maintains the mixture ratio within the range of stoichiometric (ideal air-fuel mixture). This stage is referred to as the closed loop control condition.

Heated oxygen sensor 2 is located downstream of the three way catalyst 1. Even if the switching characteristics of A/F sensor 1 shift, the air-fuel ratio is controlled to stoichiometric by the signal from heated oxygen sensor 2.

### • Open Loop Control

The open loop system condition refers to when the ECM detects any of the following conditions. Feedback control stops in order to maintain stabilized fuel combustion.

- Deceleration and acceleration
- High-load, high-speed operation
- Malfunction of A/F sensor 1 or its circuit
- Insufficient activation of A/F sensor 1 at low engine coolant temperature
- High engine coolant temperature
- During warm-up
- After shifting from N to D
- When starting the engine

## MIXTURE RATIO SELF-LEARNING CONTROL

The mixture ratio feedback control system monitors the mixture ratio signal transmitted from A/F sensor 1. This feedback signal is then sent to the ECM. The ECM controls the basic mixture ratio as close to the theoretical mixture ratio as possible. However, the basic mixture ratio is not necessarily controlled as originally designed. Both manufacturing differences (i.e., mass air flow sensor hot wire) and characteristic changes during operation (i.e., fuel injector clogging) directly affect mixture ratio.

Accordingly, the difference between the basic and theoretical mixture ratios is monitored in this system. This is then computed in terms of "injection pulse duration" to automatically compensate for the difference between the two ratios.

"Fuel trim" refers to the feedback compensation value compared against the basic injection duration. Fuel trim includes short-term fuel trim and long-term fuel trim.

"Short-term fuel trim" is the short-term fuel compensation used to maintain the mixture ratio at its theoretical value. The signal from A/F sensor 1 indicates whether the mixture ratio is RICH or LEAN compared to the theoretical value. The signal then triggers a reduction in fuel volume if the mixture ratio is rich, and an increase in fuel volume if it is lean.

"Long-term fuel trim" is overall fuel compensation carried out over time to compensate for continual deviation of the short-term fuel trim from the central value. Continual deviation will occur due to individual engine differences, wear over time and changes in the usage environment.

## FUEL INJECTION TIMING

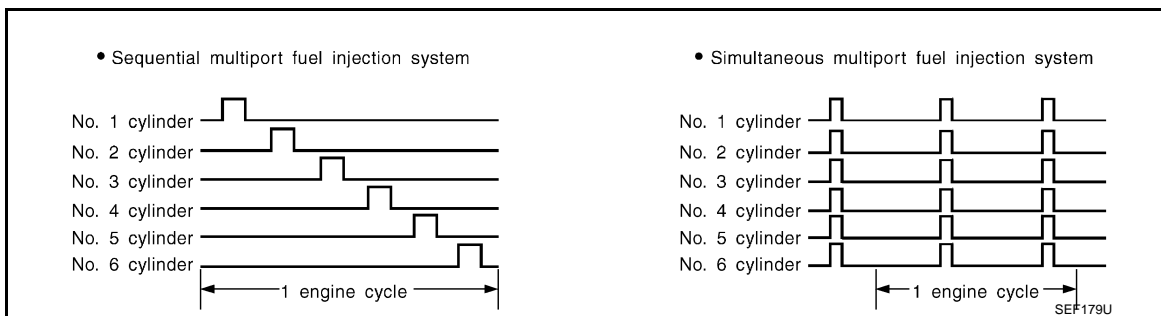

Two types of systems are used.

### • Sequential Multiport Fuel Injection System

Fuel is injected into each cylinder during each engine cycle according to the firing order. This system is used when the engine is running.

### • Simultaneous Multiport Fuel Injection System

Fuel is injected simultaneously into all six cylinders twice each engine cycle. In other words, pulse signals of the same width are simultaneously transmitted from the ECM.

The six injectors will then receive the signals two times for each engine cycle.

This system is used when the engine is being started and/or if the fail-safe system (CPU) is operating.

## FUEL SHUT-OFF

# SYSTEM

< SYSTEM DESCRIPTION >

[VQ37VHR FOR USA AND CANADA]

Fuel to each cylinder is cut off during deceleration, operation of the engine at excessively high speeds or operation of the vehicle at excessively high speeds.

## ELECTRIC IGNITION SYSTEM

### ELECTRIC IGNITION SYSTEM : System Diagram

INFOID:000000006882788

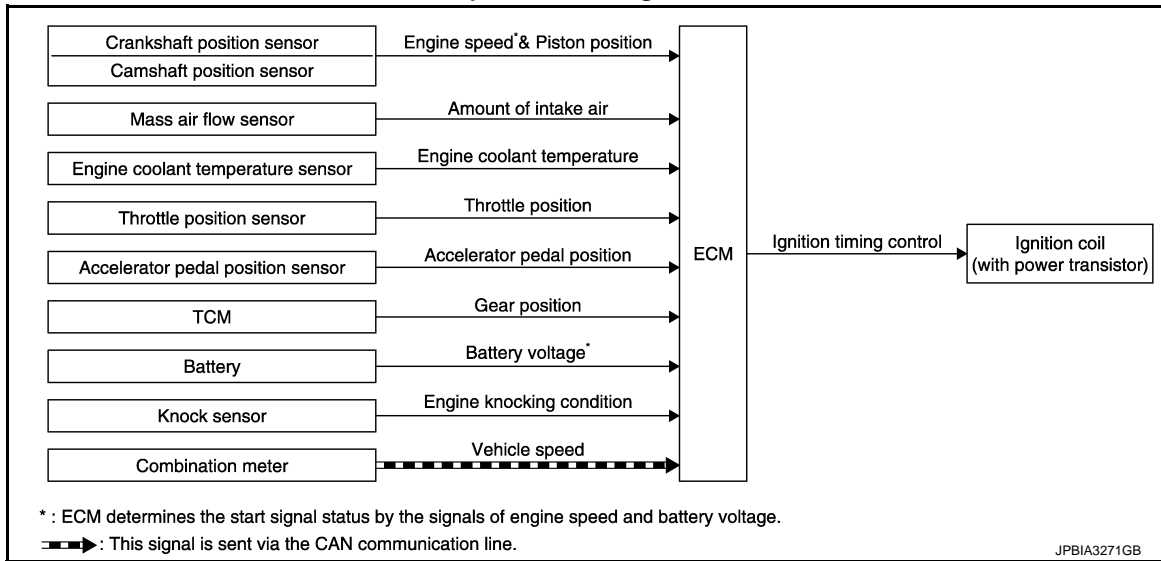

### ELECTRIC IGNITION SYSTEM : System Description

INFOID:000000006882789

#### INPUT/OUTPUT SIGNAL CHART

| Sensor                            | Input Signal to ECM               | ECM function            | Actuator                              |
|-----------------------------------|-----------------------------------|-------------------------|---------------------------------------|
| Crankshaft position sensor (POS)  | Engine speed*2<br>Piston position | Ignition timing control | Ignition coil (with power transistor) |
| Camshaft position sensor (PHASE)  |                                   |                         |                                       |
| Mass air flow sensor              | Amount of intake air              |                         |                                       |
| Engine coolant temperature sensor | Engine coolant temperature        |                         |                                       |
| Throttle position sensor          | Throttle position                 |                         |                                       |
| Accelerator pedal position sensor | Accelerator pedal position        |                         |                                       |
| TCM                               | Gear position                     |                         |                                       |
| Battery                           | Battery voltage*2                 |                         |                                       |
| Knock sensor                      | Engine knocking                   |                         |                                       |
| Combination meter                 | Vehicle speed*1                   |                         |                                       |

\*1: This signal is sent to the ECM via the CAN communication line.

\*2: ECM determines the start signal status by the signals of engine speed and battery voltage.

#### SYSTEM DESCRIPTION

Ignition order: 1 - 2 - 3 - 4 - 5 - 6

The ignition timing is controlled by the ECM to maintain the best air-fuel ratio for every running condition of the engine. The ignition timing data is stored in the ECM.

The ECM receives information such as the injection pulse width and camshaft position sensor (PHASE) signal. Computing this information, ignition signals are transmitted to the power transistor.

During the following conditions, the ignition timing is revised by the ECM according to the other data stored in the ECM.

- At starting
- During warm-up
- At idle
- At low battery voltage
- During acceleration

# SYSTEM

< SYSTEM DESCRIPTION >

[VQ37VHR FOR USA AND CANADA]

The knock sensor retard system is designed only for emergencies. The basic ignition timing is programmed within the anti-knocking zone, if recommended fuel is used under dry conditions. The retard system does not operate under normal driving conditions. If engine knocking occurs, the knock sensor monitors the condition. The signal is transmitted to the ECM. The ECM retards the ignition timing to eliminate the knocking condition.

## AIR CONDITIONING CUT CONTROL

### AIR CONDITIONING CUT CONTROL : System Diagram

INFOID:000000006882790

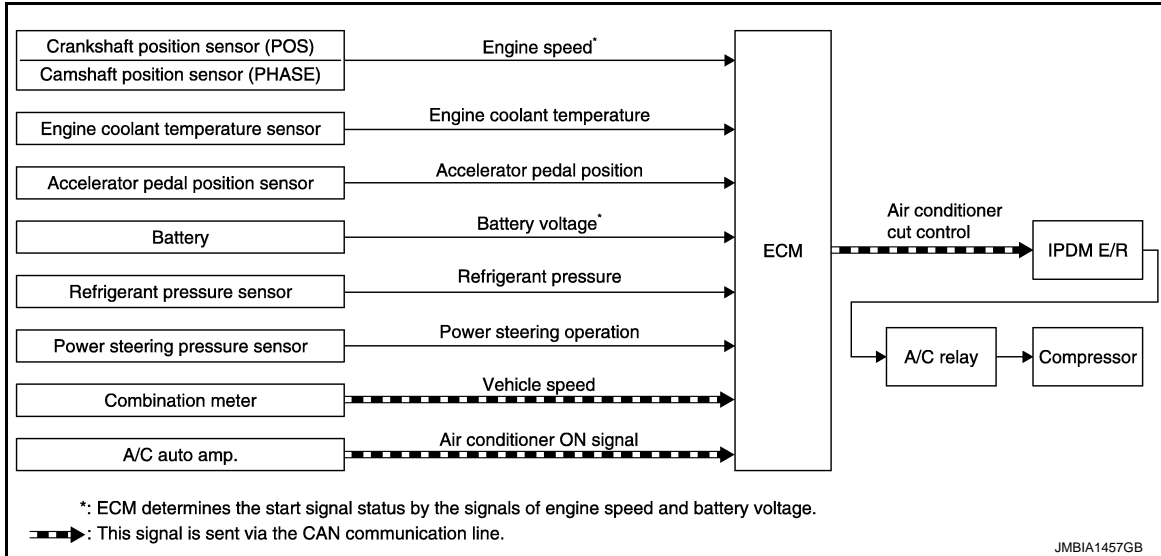

### AIR CONDITIONING CUT CONTROL : System Description

INFOID:000000006882791

#### INPUT/OUTPUT SIGNAL CHART

| Sensor   | Input Signal to ECM         | ECM function                | Actuator                                      |
|--|-----------------------------|-----------------------------|---|
| Crankshaft position sensor (POS)<br>Camshaft position sensor (PHASE) | Engine speed*2              | Air conditioner cut control | IPDM E/R<br>↓<br>A/C relay<br>↓<br>Compressor |
| Engine coolant temperature sensor                                    | Engine coolant temperature  |                             |   |
| Accelerator pedal position sensor                                    | Accelerator pedal position  |                             |   |
| Battery  | Battery voltage*2           |                             |   |
| Refrigerant pressure sensor  | Refrigerant pressure        |                             |   |
| Power steering pressure sensor                                       | Power steering operation    |                             |   |
| Combination meter  | Vehicle speed*1             |                             |   |
| A/C auto amp.  | Air conditioner ON signal*1 |                             |   |

\*1: This signal is sent to the ECM via the CAN communication line.

\*2: ECM determines the start signal status by the signals of engine speed and battery voltage.

#### SYSTEM DESCRIPTION

This system improves engine operation when the air conditioner is used. Under the following conditions, the air conditioner is turned off.

- When the accelerator pedal is fully depressed.
- When cranking the engine.
- At high engine speeds.
- When the engine coolant temperature becomes excessively high.
- When operating power steering during low engine speed or low vehicle speed.
- When engine speed is excessively low.
- When refrigerant pressure is excessively low or high.

#### AUTOMATIC SPEED CONTROL DEVICE (ASCD)

# SYSTEM

< SYSTEM DESCRIPTION >

[VQ37VHR FOR USA AND CANADA]

## AUTOMATIC SPEED CONTROL DEVICE (ASCD) : System Diagram

INFOID:000000006882792

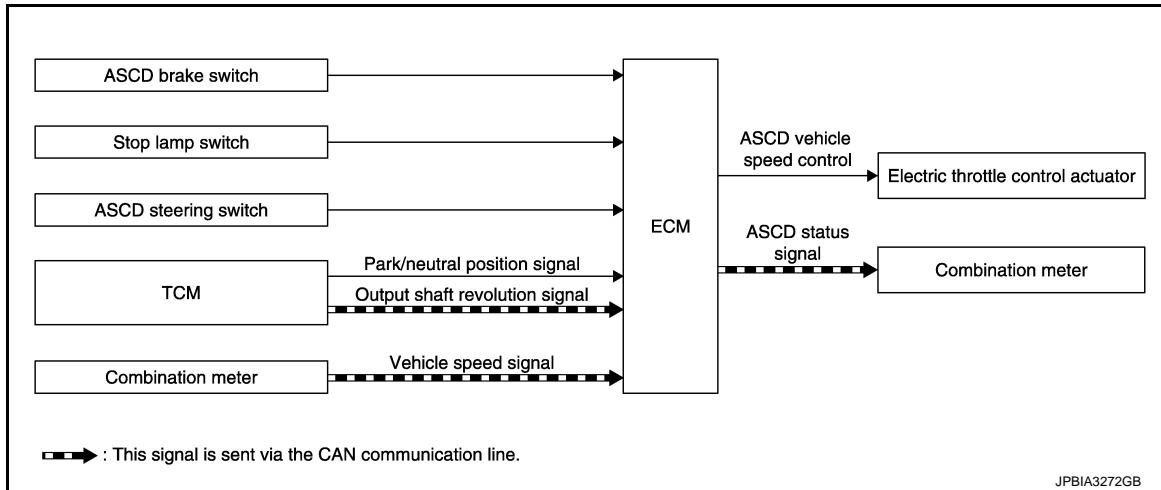

## AUTOMATIC SPEED CONTROL DEVICE (ASCD) : System Description

INFOID:000000006882793

### INPUT/OUTPUT SIGNAL CHART

| Sensor               | Input signal to ECM             | ECM function               | Actuator                           |
|----------------------|---------------------------------|----------------------------|------------------------------------|
| ASCD brake switch    | Brake pedal operation           | ASCD vehicle speed control | Electric throttle control actuator |
| Stop lamp switch     | Brake pedal operation           |                            |                                    |
| ASCD steering switch | ASCD steering switch operation  |                            |                                    |
| TCM                  | Park/neutral position signal    | ASCD status signal         | Combination meter                  |
|                      | Output shaft revolution signal* |                            |                                    |
| Combination meter    | Vehicle speed*                  |                            |                                    |

\*: This signal is sent to the ECM via the CAN communication line

### BASIC ASCD SYSTEM

Refer to Owner's Manual for ASCD operating instructions.

Automatic Speed Control Device (ASCD) allows a driver to keep vehicle at predetermined constant speed without depressing accelerator pedal. Driver can set vehicle speed in advance between approximately 40 km/h (25 MPH) and 144 km/h (89 MPH).

ECM controls throttle angle of electric throttle control actuator to regulate engine speed.

Operation status of ASCD is indicated by CRUISE indicator and SET indicator in combination meter. If any malfunction occurs in the ASCD system, it automatically deactivates control.

#### NOTE:

**Always drive vehicle in a safe manner according to traffic conditions and obey all traffic laws.**

### SET OPERATION

Press MAIN switch. (The CRUISE indicator in combination meter illuminates.)

When vehicle speed reaches a desired speed between approximately 40 km/h (25 MPH) and 144 km/h (89 MPH), press SET/COAST switch. (Then SET lamp in combination meter illuminates.)

### ACCELERATE OPERATION

If the RESUME/ACCELERATE switch is pressed during cruise control driving, increase the vehicle speed until the switch is released or vehicle speed reaches maximum speed controlled by the system.

And then ASCD will maintain the new set speed.

### CANCEL OPERATION

When any of following conditions exist, cruise operation will be canceled.

- CANCEL switch is pressed
- More than 2 switches at ASCD steering switch are pressed at the same time (Set speed will be cleared)
- Brake pedal is depressed
- Selector lever is in the N, P, R position
- Vehicle speed decreased to 13 km/h (8 MPH) lower than the set speed

## < SYSTEM DESCRIPTION >

- TCS system is operated

When the ECM detects any of the following conditions, the ECM will cancel the cruise operation and inform the driver by blinking indicator lamp.

- Engine coolant temperature is slightly higher than the normal operating temperature, CRUISE lamp may blink slowly.

When the engine coolant temperature decreases to the normal operating temperature, CRUISE lamp will stop blinking and the cruise operation will be able to work by pressing SET/COAST switch or RESUME/ACCELERATE switch.

- Malfunction for some self-diagnoses regarding ASCD control: SET indicator will blink quickly.

If MAIN switch is turned to OFF while ASCD is activated, all of ASCD operations will be canceled and vehicle speed memory will be erased.

### COAST OPERATION

When the SET/COAST switch is pressed during cruise control driving, decrease vehicle set speed until the switch is released. And then ASCD will maintain the new set speed.

### RESUME OPERATION

When the RESUME/ACCELERATE switch is pressed after cancel operation other than pressing MAIN switch is performed, vehicle speed will return to last set speed. To resume vehicle set speed, vehicle condition must meet following conditions.

- Brake pedal is released
- A/T selector lever is in the P and N positions
- Vehicle speed is greater than 40 km/h (25 MPH) and less than 144 km/h (89 MPH)

## CAN COMMUNICATION

### CAN COMMUNICATION : System Description

INFOID:000000006882794

CAN (Controller Area Network) is a serial communication line for real time application. It is an on-vehicle multiplex communication line with high data communication speed and excellent error detection ability. Many electronic control units are equipped onto a vehicle, and each control unit shares information and links with other control units during operation (not independent). In CAN communication, control units are connected with 2 communication lines (CAN H line, CAN L line) allowing a high rate of information transmission with less wiring. Each control unit transmits/receives data but selectively reads required data only.

Refer to [LAN-17. "CAN COMMUNICATION SYSTEM : CAN Communication Control Circuit"](#), about CAN communication for detail.

## COOLING FAN CONTROL

### COOLING FAN CONTROL : System Diagram

INFOID:000000006882795

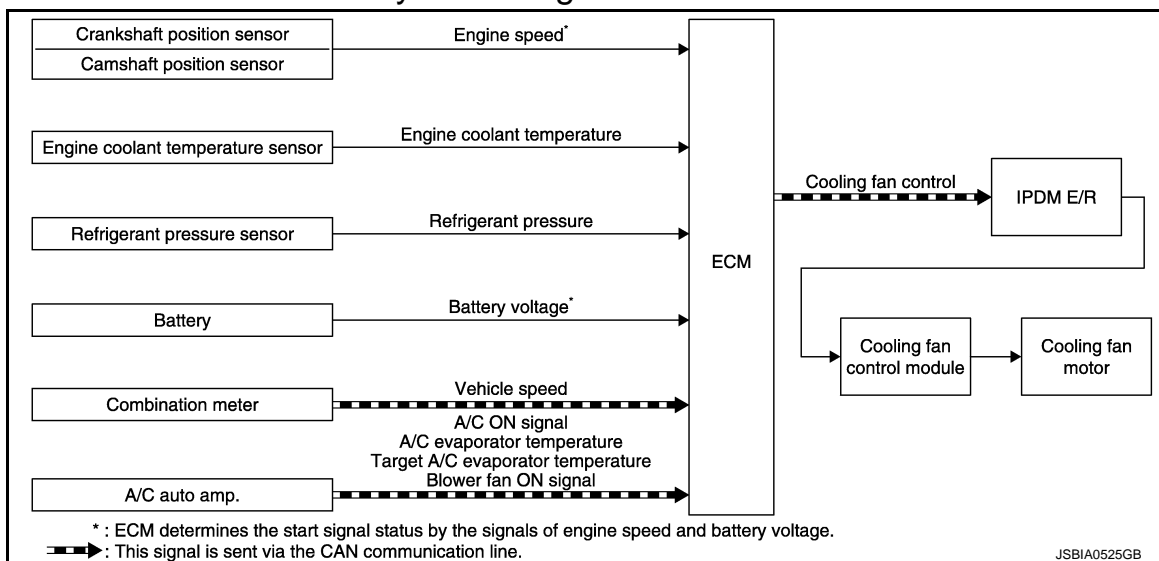

### COOLING FAN CONTROL : System Description

INFOID:000000006882796

## INPUT/OUTPUT SIGNAL CHART



# SYSTEM

< SYSTEM DESCRIPTION >

[VQ37VHR FOR USA AND CANADA]

| Sensor   | Input signal to ECM                 | ECM function        | Actuator  |
|--|-------------------------------------|---------------------|---|
| Crankshaft position sensor (POS)<br>Camshaft position sensor (PHASE) | Engine speed*1                      | Cooling fan control | IPDM E/R<br>↓<br>Cooling fan control module<br>↓<br>Cooling fan motor |
| Engine coolant temperature sensor                                    | Engine coolant temperature          |                     |   |
| Refrigerant pressure sensor  | Refrigerant pressure                |                     |   |
| Battery  | Battery voltage*1                   |                     |   |
| Combination meter  | Vehicle speed*2                     |                     |   |
| A/C auto amp.  | A/C ON signal*2                     |                     |   |
|  | A/C evaporator temperature*2        |                     |   |
|  | Target A/C evaporator temperature*2 |                     |   |
|  | Blower fan ON signal*2              |                     |   |

\*1: The ECM determines the start signal status by the signals of engine speed and battery voltage.

\*2: This signal is sent to ECM via the CAN communication line.

## SYSTEM DESCRIPTION

ECM controls cooling fan speed corresponding to vehicle speed, engine coolant temperature, air conditioner ON signal, refrigerant pressure, target A/C evaporator temperature and A/C evaporator temperature. Cooling fan control signal is sent to IPDM E/R from ECM by CAN communication line. Then, IPDM E/R sends ON/OFF pulse duty signal to cooling fan control module. Corresponding to this ON/OFF pulse duty signal, cooling fan control module gives cooling fan motor operating voltage to cooling fan motors. Cooling fan speed is controlled by duty cycle of cooling fan motor operating voltage sent from cooling fan control module.

## EVAPORATIVE EMISSION SYSTEM

### EVAPORATIVE EMISSION SYSTEM : System Diagram

INFOID:000000006882797

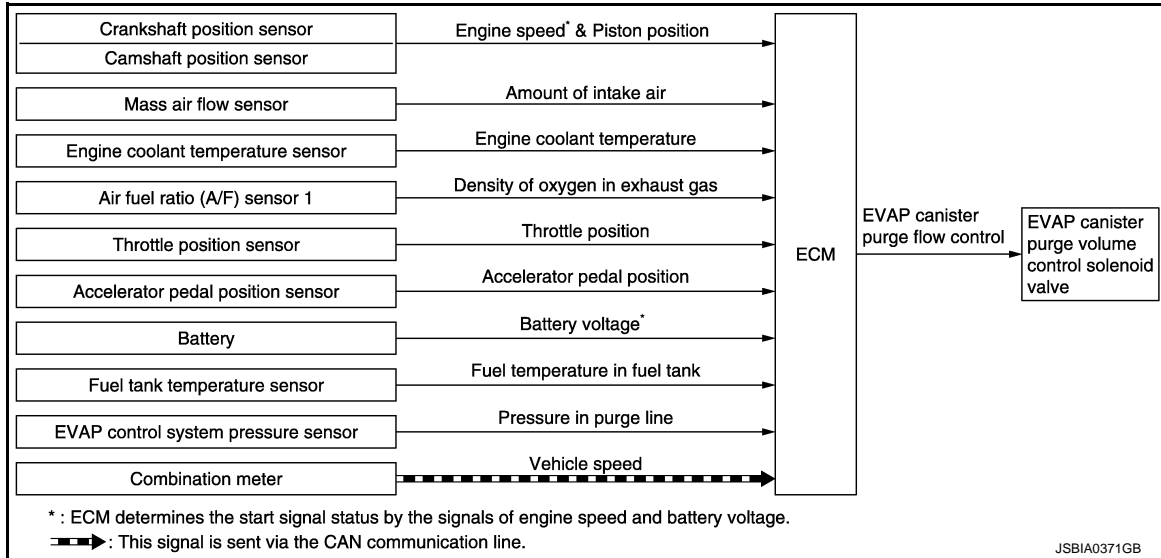

### EVAPORATIVE EMISSION SYSTEM : System Description

INFOID:000000006882798

### INPUT/OUTPUT SIGNAL CHART

# SYSTEM

< SYSTEM DESCRIPTION >

[VQ37VHR FOR USA AND CANADA]

| Sensor   | Input signal to ECM   | ECM function                        | Actuator   |
|--|---|-------------------------------------|--|
| Crankshaft position sensor<br>Camshaft position sensor | Engine speed*1  | EVAP canister<br>purge flow control | EVAP canister purge volume<br>control solenoid valve |
| Mass air flow sensor                                   | Amount of intake air  |                                     |  |
| Engine coolant temperature sensor                      | Engine coolant temperature  |                                     |  |
| Battery  | Battery voltage*1   |                                     |  |
| Throttle position sensor                               | Throttle position   |                                     |  |
| Accelerator pedal position sensor                      | Accelerator pedal position  |                                     |  |
| Air fuel ratio (A/F) sensor 1                          | Density of oxygen in exhaust gas<br>(Mixture ratio feedback signal) |                                     |  |
| Fuel tank temperature sensor                           | Fuel temperature in fuel tank                                       |                                     |  |
| EVAP control system pressure sensor                    | Pressure in purge line  |                                     |  |
| Combination meter                                      | Vehicle speed*2   |                                     |  |

\*1: ECM determines the start signal status by the signals of engine speed and battery voltage.

\*2: This signal is sent to the ECM via the CAN communication line.

## SYSTEM DESCRIPTION

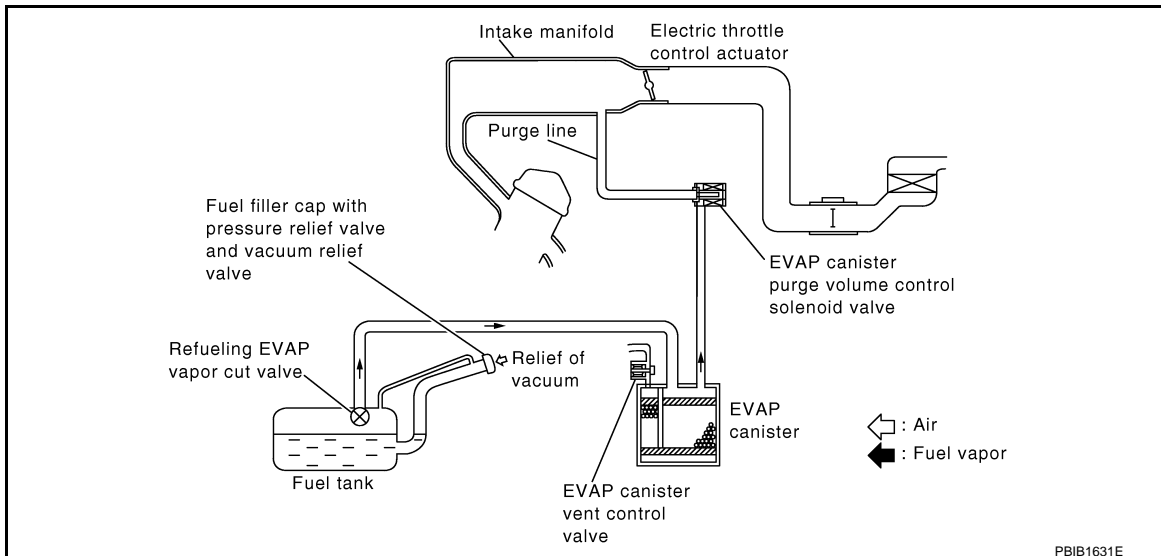

The evaporative emission system is used to reduce hydrocarbons emitted into the atmosphere from the fuel system. This reduction of hydrocarbons is accomplished by activated charcoals in the EVAP canister. The fuel vapor in the sealed fuel tank is led into the EVAP canister which contains activated carbon and the vapor is stored there when the engine is not operating or when refueling to the fuel tank. The vapor in the EVAP canister is purged by the air through the purge line to the intake manifold when the engine is operating. EVAP canister purge volume control solenoid valve is controlled by ECM. When the engine operates, the flow rate of vapor controlled by EVAP canister purge volume control solenoid valve is proportionally regulated as the air flow increases. EVAP canister purge volume control solenoid valve also shuts off the vapor purge line during decelerating and idling.

## ENGINE PROTECTION CONTROL AT LOW ENGINE OIL PRESSURE

ENGINE PROTECTION CONTROL AT LOW ENGINE OIL PRESSURE : System Dia-

gram

INFOID:000000007768313

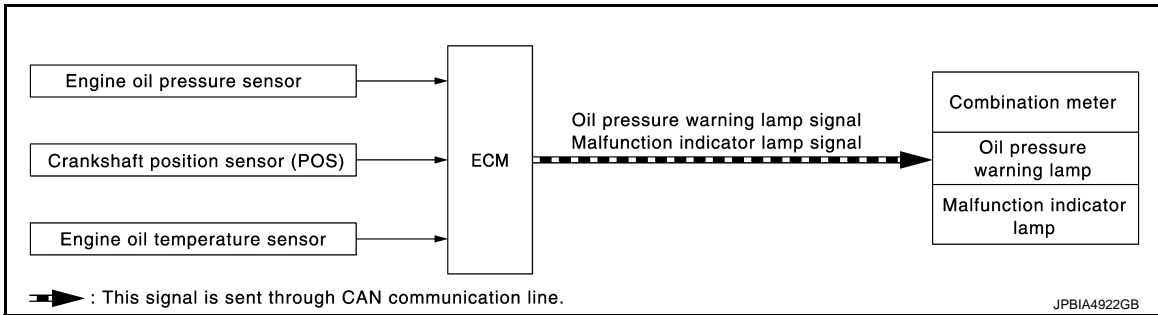

## ENGINE PROTECTION CONTROL AT LOW ENGINE OIL PRESSURE : System Description

INFOID:000000007768314

### INPUT/OUTPUT SIGNAL CHART

| Sensor                           | Input signal to ECM    | ECM function  | Actuator   |
|----------------------------------|------------------------|---|--|
| Engine oil pressure sensor       | Engine pressure        | Engine protection control<br>• Oil pressure warning lamp signal<br>• FUEl cut control | Combination meter<br>• Oil pressure warning lamp |
| Crankshaft position sensor (POS) | Engine speed           |   |  |
| Engine oil temperature sensor    | Engine oil temperature |   |  |

### SYSTEM DESCRIPTION

- The engine protection control at low engine oil pressure warns the driver of a decrease in engine oil pressure by the oil pressure warning lamp a before the engine becomes damaged.
- When detecting a decrease in engine oil pressure at an engine speed less than 1,000 rpm, ECM transmits an oil pressure warning lamp signal to the combination meter. The combination meter turns ON the oil pressure warning lamp, according to the signal.

| Decrease in engine oil pressure | Engine speed        | Combination meter         |
|---------------------------------|---------------------|---------------------------|
|                                 |                     | Oil pressure warning lamp |
| Detection                       | Less than 1,000 rpm | ON*                       |
|                                 | 1,000 rpm or more   | ON                        |

\*: When detecting a normal engine oil pressure, ECM turns OFF the oil pressure warning lamp.

## FUEL FILLER CAP WARNING SYSTEM

### FUEL FILLER CAP WARNING SYSTEM : System Diagram

INFOID:000000007202566

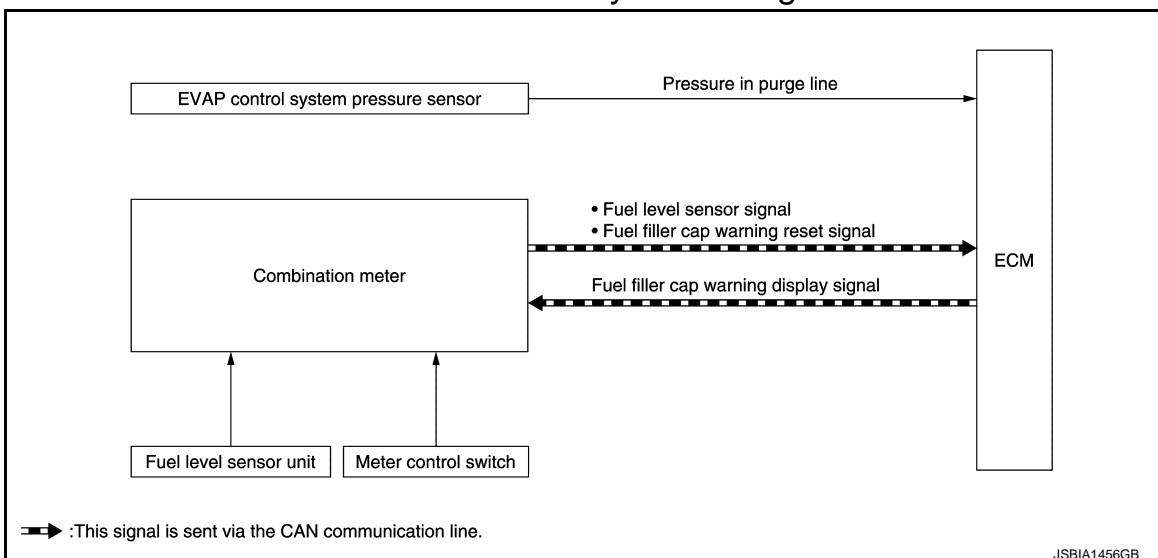

# SYSTEM

< SYSTEM DESCRIPTION >

[VQ37VHR FOR USA AND CANADA]

## FUEL FILLER CAP WARNING SYSTEM : System Description

INFOID:000000007202567

### INPUT/OUTPUT SIGNAL CHART

Input

| Unit/Sensor                         | Input signal to ECM                   | ECM function                    |
|-------------------------------------|---------------------------------------|---------------------------------|
| EVAP control system pressure sensor | Pressure in purge line                | Fuel filler cap warning control |
| Combination meter                   | Fuel level signal*                    |                                 |
|                                     | Fuel filler cap warning reset signal* |                                 |

\*: This signal is sent to the ECM via the CAN communication line.

Output

| Unit | Output signal                           | Actuator          |
|------|---|-------------------|
| ECM  | Fuel filler cap warning display signal* | Combination meter |

\*: This signal is sent to the combination meter via the CAN communication line.

### SYSTEM DESCRIPTION

The fuel filler cap warning system alerts the driver to the prevention of the fuel filler being left uncapped and malfunction occurrences after refueling, by turning ON the fuel filler cap warning display on the combination meter.

ECM judges a refueled state, based on a fuel level signal transmitted from the combination meter.

When a very small leak is detected through the EVAP leak diagnosis performed after judging the refueled state, ECM transmits a fuel filler cap warning display signal (request for display ON) to the combination meter via CAN communication.

When receiving the signal, the combination meter turns ON the fuel filler cap warning display.

#### CAUTION:

**Check fuel filler cap installation condition when the fuel filler cap warning display turns ON.**

#### Reset Operation

The fuel filler cap warning lamp turns OFF, according to any condition listed below:

- Reset operation is performed by operating the meter control switch on the combination meter. Refer to [MWI-19. "INFORMATION DISPLAY : System Description"](#).
- When the reset operation is performed, the combination meter transmits a fuel filler cap warning reset signal to ECM via CAN communication. ECM transmits a fuel filler cap warning display signal (request for display OFF) to the combination meter via CAN communication. When receiving the signal, the combination meter turns OFF the fuel filler cap warning display.
- EVAP leak diagnosis result is normal.
- Fuel refilled.
- DTC erased by using CONSULT.

#### NOTE:

MIL turns ON if a malfunction is detected in leak diagnosis results again at the trip after the fuel filler cap warning display turns ON/OFF.

### INTAKE VALVE TIMING CONTROL

#### INTAKE VALVE TIMING CONTROL : System Diagram

INFOID:000000006882799

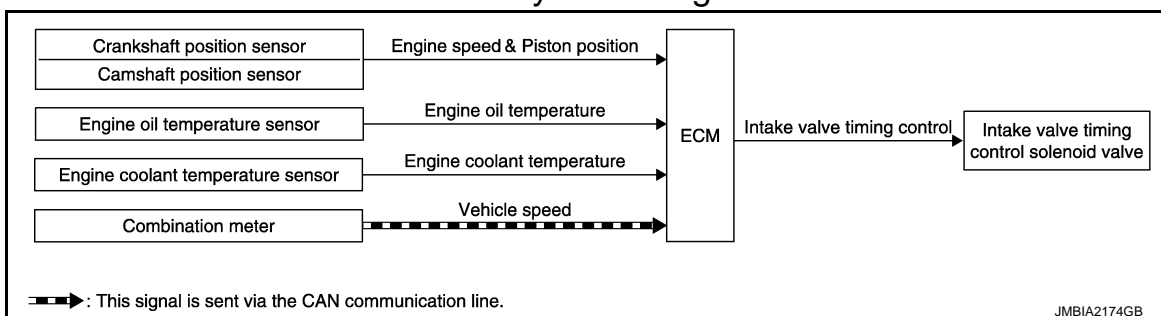

#### INTAKE VALVE TIMING CONTROL : System Description

INFOID:000000006882800

### INPUT/OUTPUT SIGNAL CHART

# SYSTEM

< SYSTEM DESCRIPTION >

[VQ37VHR FOR USA AND CANADA]

| Sensor                            | Input signal to ECM              | ECM function                | Actuator                                   |
|-----------------------------------|----------------------------------|-----------------------------|--|
| Crankshaft position sensor (POS)  | Engine speed and piston position | Intake valve timing control | Intake valve timing control solenoid valve |
| Camshaft position sensor (PHASE)  |                                  |                             |  |
| Engine oil temperature sensor     | Engine oil temperature           |                             |  |
| Engine coolant temperature sensor | Engine coolant temperature       |                             |  |
| Combination meter                 | Vehicle speed*                   |                             |  |

\*: This signal is sent to the ECM via the CAN communication line

## SYSTEM DESCRIPTION

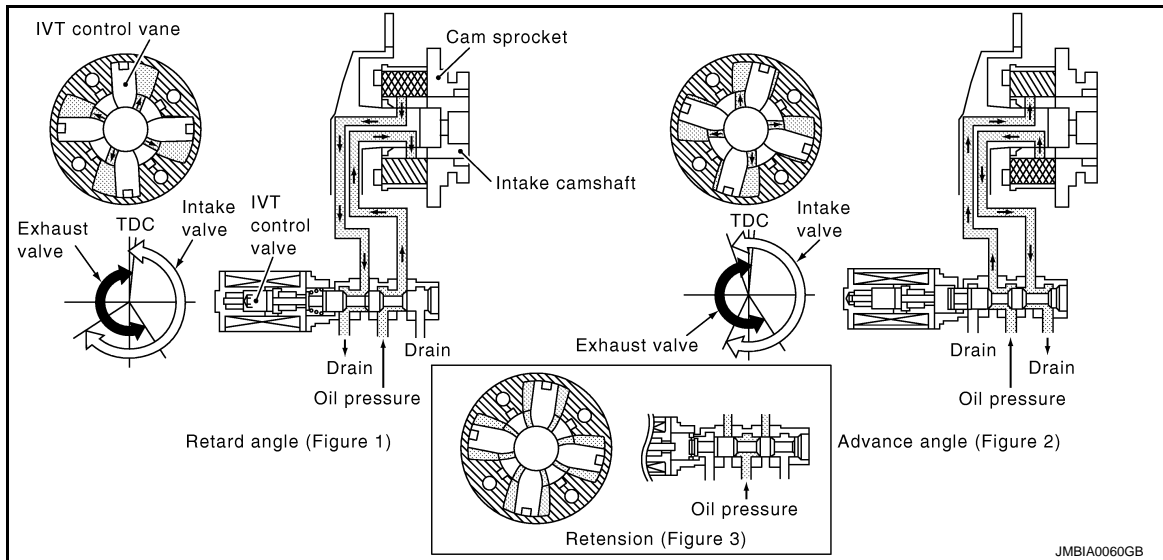

This mechanism hydraulically controls cam phases continuously with the fixed operating angle of the intake valve.

The ECM receives signals such as crankshaft position, camshaft position, engine speed, and engine coolant temperature. Then, the ECM sends ON/OFF pulse duty signals to the intake valve timing (IVT) control solenoid valve depending on driving status. This makes it possible to control the shut/open timing of the intake valve to increase engine torque in low/mid speed range and output in high-speed range.

## VVEL SYSTEM

### VVEL SYSTEM : System Diagram

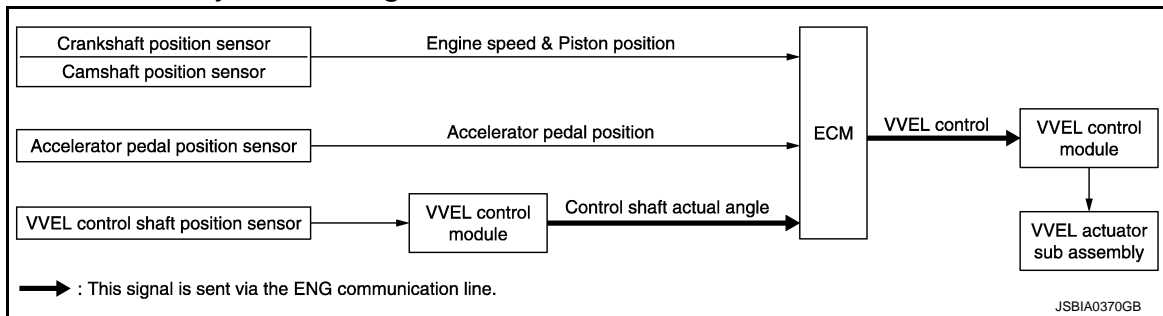

### VVEL SYSTEM : System Description

#### INPUT/OUTPUT SIGNAL CHART

# SYSTEM

< SYSTEM DESCRIPTION >

[VQ37VHR FOR USA AND CANADA]

| Sensor   | Input signal to ECM              | ECM function | Actuator   |
|--|----------------------------------|--------------|--|
| Camshaft position sensor<br>Crankshaft position sensor         | Engine speed and piston position | VVEL control | VVEL control module<br>↓<br>VVEL actuator sub assembly |
| Accelerator pedal position sensor                              | Accelerator pedal position       |              |  |
| VVEL control shaft position sensor<br>↓<br>VVEL control module | Control shaft actual angle       |              |  |

## SYSTEM DESCRIPTION

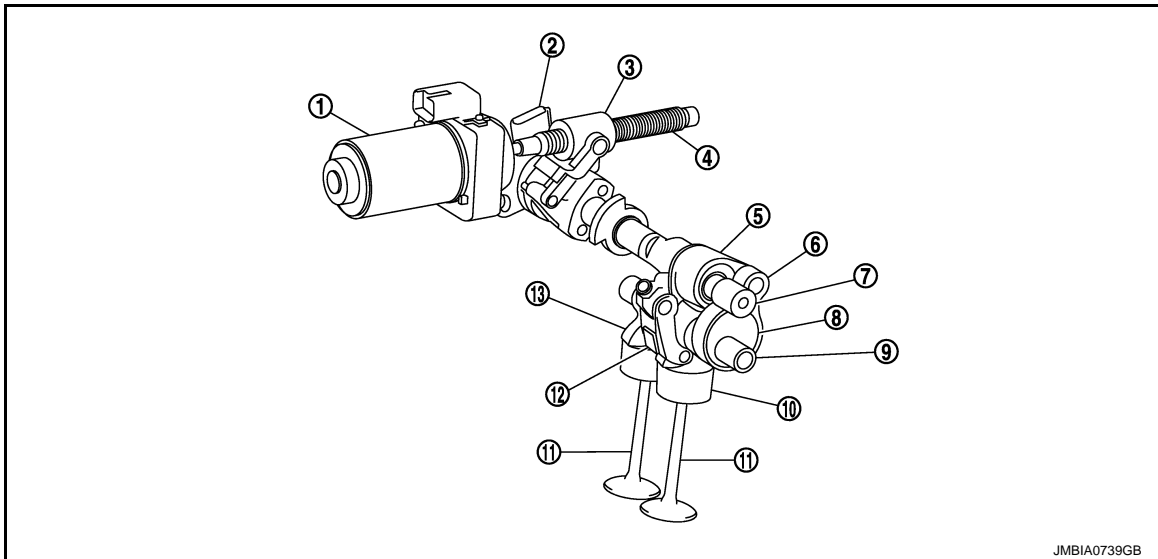

JMBIA0739GB

- |                        |                                       |                   |
|------------------------|---------------------------------------|-------------------|
| 1. VVEL actuator motor | 2. VVEL control shaft position sensor | 3. Ball screw nut |
| 4. Ball screw shaft    | 5. Rocker arm                         | 6. Link A         |
| 7. Control shaft       | 8. Eccentric cam                      | 9. Drive shaft    |
| 10. Valve lifter       | 11. Intake valve                      | 12. Link B        |
| 13. Output cam         |                                       |                   |

VVEL (Variable Valve Event & Lift) is a system that controls valve event and valve lift continuously. Rotational movement of the drive shaft equipped with eccentric cam is transmitted to output cam via the rocker arm and two kinds of links to depress the intake valve. ECM decides the target valve lift according to the driving condition and sends the command signal to the VVEL control module. The VVEL control module controls the rotation of the control shaft using the VVEL actuator motor and changes the movement of the output cam by shifting the link supporting point. As a result, valve lift changes continuously to improve engine output and response.

## Infiniti Drive Mode Selector

## Infiniti Drive Mode Selector : System Description

INFOID:000000006882803

### System Diagram

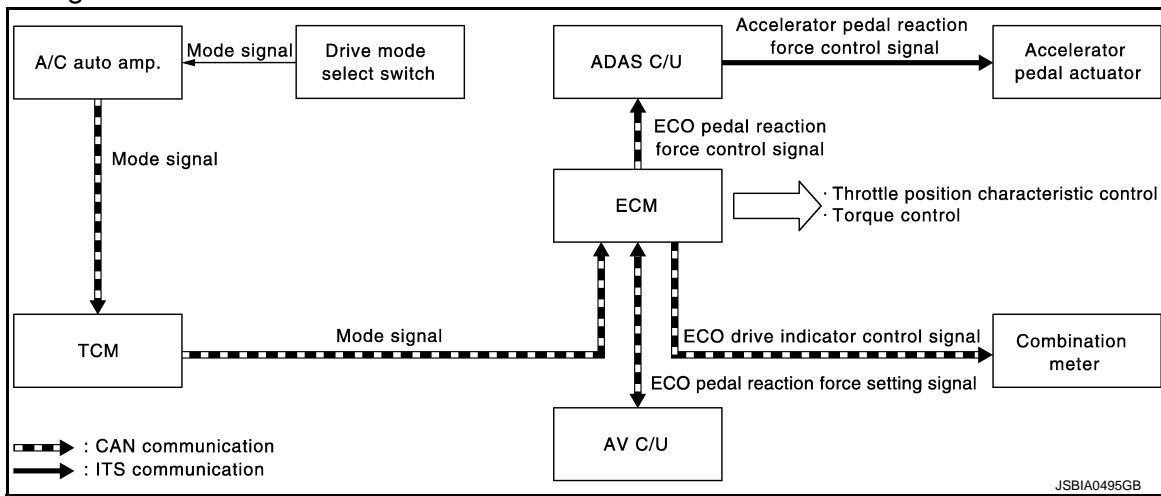

#### NOTE:

- This section provides descriptions only about the control by ECM.  
For overall control, refer to [DMS-5, "Infiniti Drive Mode Selector : System Description"](#).
- ECO pedal control is only for vehicles with intelligent pedal (distance control assist).

#### Infiniti drive mode selector

- A/C auto amp. receives an operation state signal of the drive mode select switch and transmits a mode signal (see below) to TCM via CAN communication.
  - STANDARD: ON/OFF
  - SPORT: ON/OFF
  - ECO: ON/OFF
  - SNOW: ON/OFF
- TCM transmits a mode state signal to ECM via CAN communication, based on a ECO mode signal received from the A/C auto amp.
- ECM controls throttle angle characteristics and torque appropriate to each mode, based on a ECO mode signal received from TCM via CAN communication.
- The combination meter turns ON or blinks (with ECO pedal) the ECO drive indicator when in ECO mode, based on a ECO drive indicator control signal received from ECM via CAN communication.

#### ECO pedal control

- The AV control unit transmits an ECO pedal reaction force setting signal (Standard/Soft/OFF) to ECM via CAN communication.

#### NOTE:

- An ECO pedal reaction force setting signal which determines reaction force of the accelerator pedal can be selected on the settings screen of the Multi AV system.
- ECM transmits an ECO pedal reaction force control signal to the ADAS control unit via CAN communication, based on a ECO mode signal received from TCM via CAN communication and an ECO pedal reaction force setting signal received from the AV control unit via CAN communication.
- ECM sends back an ECO pedal reaction force setting signal received from the AV control unit to the AV control unit for confirmation.
- The ADAS control unit controls pedal reaction force of the accelerator pedal actuator via ITS communication, based on an ECO pedal reaction force control signal received from the ADAS control unit.

#### Control

- With the drive mode selector, a drive mode select switch installed at the top of the center console switches a vehicle drive mode, changes throttle angle characteristics, and controls torque and ECO pedal.
- Vehicle characteristics are controlled in the following modes, on the basis of STANDARD mode ("●" position of the drive mode select switch).
  - SPORT: Changing throttle angle characteristics allows to use a high engine performance range and increases driving performance.
  - ECO: Changing throttle angle characteristics and controlling torque, ECO drive indicator, and ECO pedal enhance fuel economy in actual traffic.

# SYSTEM

## < SYSTEM DESCRIPTION >

[VQ37VHR FOR USA AND CANADA]

- SNOW: Changing throttle angle characteristics enhances driving performance on roads with a low coefficient of friction.

| Control item            | Vehicle drive mode |     |      | Description  |
|-------------------------|--------------------|-----|------|--|
|                         | SPORT              | ECO | SNOW |  |
| Engine                  | ×                  | ×   | ×    | Changes throttle angle and controls torque* <sup>1</sup> and the ECO drive indicator* <sup>1</sup> . |
| ECO pedal* <sup>2</sup> |                    | ×   |      | Controls ECO pedal (Accelerator pedal reaction force control).                                       |

\*1: Torque control and the ECO drive indicator is available only when in ECO mode.

\*2: ECO pedal control is only for vehicles with an intelligent pedal (distance control assist).

### ECO drive indicator control

- ECO drive indicator turns ON or blinks (with ECO pedal) when in ECO mode, according to the operation of the accelerator pedal.
- For vehicles with ECO pedal, the blinking timing of the ECO drive indicator (green) synchronizes to the generation timing of ECO pedal reaction force.

| ECO drive indicator                      | Driving condition   |
|--|---|
| ON (Green)                               | Within the ECO drive range.   |
| Blink (Green) (if so equipped ECO pedal) | Likely over the ECO drive range.  |
| ON (Orange)                              | Over the ECO drive range.   |
| OFF                                      | Low-speed range [approx. 3 MPH (4.8 km/h) or less] and high-speed range [approx. 90 MPH (144 km/h) or more] |

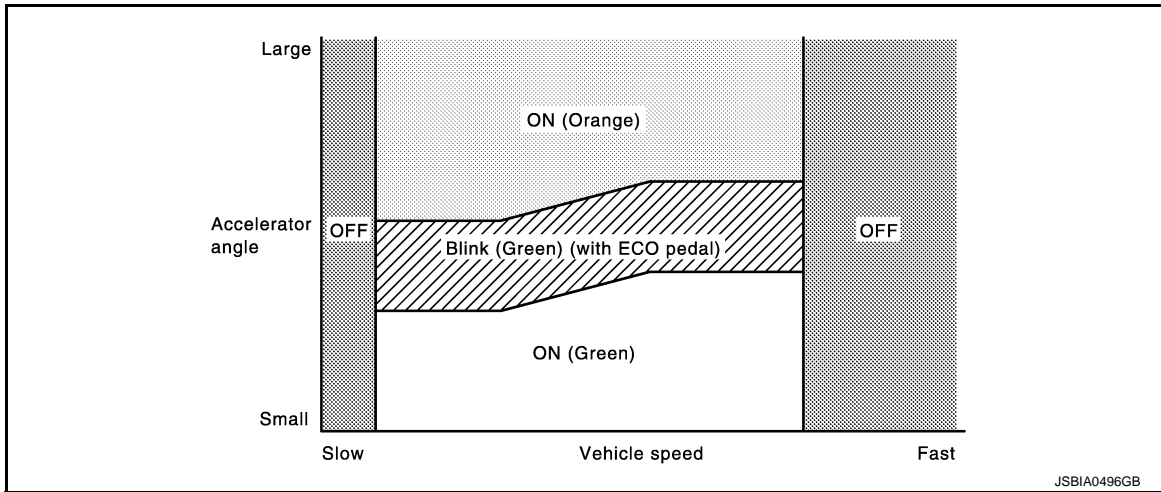

### NOTE:

ECO drive indicator turns OFF under the following conditions.

- Intelligent cruise control in operation.
- Selector lever is in R range.

### ECO pedal control

- Increasing reaction force of the accelerator pedal supports ECO driving in accordance with the accelerator pedal operation when in ECO mode.
- The level of reaction force to the accelerator pedal can be changed among Standard/Soft/OFF on the navigation screen. ECO pedal reaction force can be turned OFF even when in ECO mode.
- The generation timing of ECO pedal reaction force synchronizes to the blinking timing of the ECO drive indicator (Green).



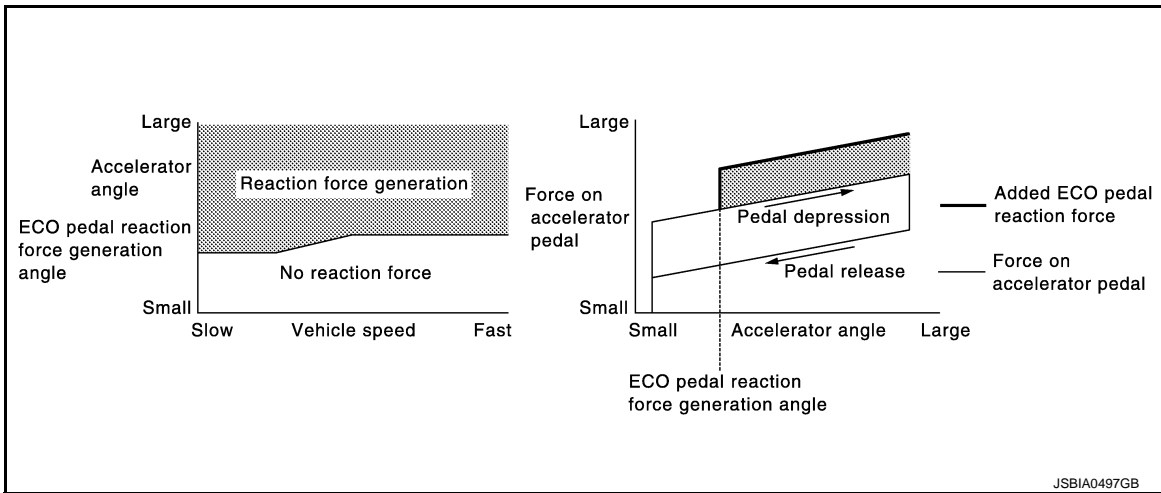

**NOTE:**

- When switching from ECO mode to the other mode by operating the drive mode select switch, ECO pedal reaction force is generated in common with ECO mode until the accelerator pedal is released.
- ECO pedal reaction force is not generated under the following conditions.
  - Intelligent cruise control is in operation.
  - Accelerator pedal is depressed quickly.
  - Selector lever is in N or R range.

A  
EC  
C  
D  
E  
F  
G  
H  
I  
J  
K  
L  
M  
N  
O  
P

# OPERATION

< SYSTEM DESCRIPTION >

[VQ37VHR FOR USA AND CANADA]

## OPERATION

### AUTMATIC SPEED CONTROL DEVICE (ASCD)

### AUTMATIC SPEED CONTROL DEVICE (ASCD) : Switch Name and Function

INFOID:000000006882804

#### SWITCHES AND INDICATORS

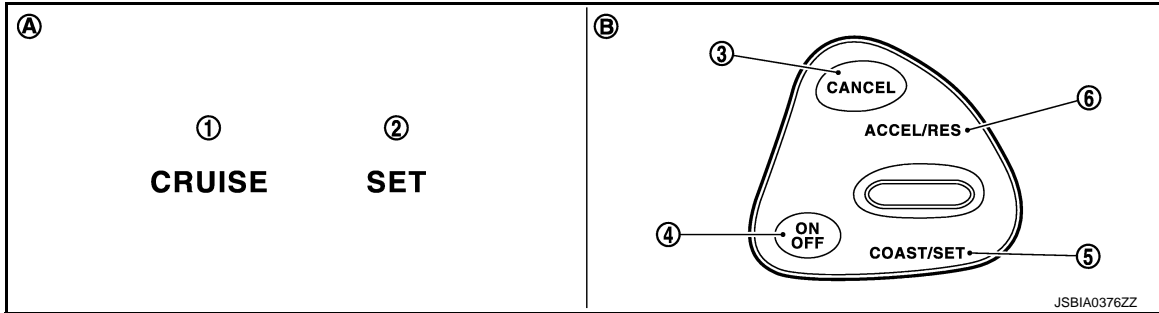

- |                     |                     |  |
|---------------------|---------------------|--|
| 1. CRUISE indicator | 2. SET indicator    | 3. CANCEL switch                           |
| 4. ASCD MAIN switch | 5. COAST/SET switch | 6. ACCEL/RES switch<br>(ACCELERATE/RESUME) |

- A. On the combination meter (Information display)  
 B. On the steering wheel

#### SET SPEED RANGE

ASCD system can be set the following vehicle speed.

| Minimum speed (Approx.) | Maximum speed (Approx.) |
|-------------------------|-------------------------|
| 40 km/h (25 MPH)        | 144 km/h (89 MPH)       |

#### SWITCH OPERATION

| Item                                  | Function   |
|---------------------------------------|--|
| CANCEL switch                         | Cancels the cruise control driving.  |
| RES / + switch<br>(RESUME/ACCELERATE) | <ul style="list-style-type: none"> <li>• Resumes the set speed.</li> <li>• Increases speed incrementally during cruise control driving.</li> </ul>     |
| SET / - switch<br>(SET/COAST)         | <ul style="list-style-type: none"> <li>• Sets desired cruise speed.</li> <li>• Decreases speed incrementally during cruise control driving.</li> </ul> |
| ASCD MAIN switch                      | Master switch to activate the ASCD system.   |

#### CANCEL OPERATION

When any of following conditions exist, cruise operation will be canceled.

- CANCEL switch is pressed
- ASCD MAIN switch pressed (Set speed is cleared)
- More than 2 switches at ASCD steering switch are pressed at the same time (Set speed will be cleared)
- Brake pedal is depressed
- Selector lever position is changed to N, P or R
- Vehicle speed decreased to 13 km/h (8 MPH) lower than the set speed
- TCS system is operated

When the ECM detects any of the following conditions, the ECM will cancel the cruise operation and inform the driver by blinking indicator.

- Engine coolant temperature is slightly higher than the normal operating temperature, CRUISE indicator may blink slowly.  
 When the engine coolant temperature decreases to the normal operating temperature, CRUISE indicator will stop blinking and the cruise operation will be able to work by pressing SET/COAST switch or RESUME/ACCELERATE switch.
- Malfunction for some self-diagnoses regarding ASCD control: SET indicator will blink quickly.

# OPERATION

[VQ37VHR FOR USA AND CANADA]

< SYSTEM DESCRIPTION >

If MAIN switch is turned to OFF during ASCD is activated, all of ASCD operations will be canceled and vehicle speed memory will be erased.

A

EC

C

D

E

F

G

H

I

J

K

L

M

N

O

P

# HANDLING PRECAUTION

< SYSTEM DESCRIPTION >

[VQ37VHR FOR USA AND CANADA]

## HANDLING PRECAUTION

### Infiniti Drive Mode Selector

INFOID:000000006882805

#### ECO DRIVE INDICATOR LAMP CONTROL

- ECO drive indicator turns OFF under the following conditions.
  - While driving at low speeds [3 MPH (4.8 km/h) or less] or high speeds [90 MPH (144 km/h) or more].
  - Intelligent cruise control is in operation.
  - Selector lever is in R range.

#### ECO PEDAL CONTROL

- When switching from ECO mode to the other mode by operating the drive mode select switch, ECO pedal reaction force is generated in common with ECO mode until the accelerator pedal is released.
- ECO pedal reaction force is not generated under the following conditions.
  - Intelligent cruise control is in operation.
  - Accelerator pedal is depressed quickly.
  - Selector lever is in N or R range.
  - ECO pedal reaction force setting is OFF.

#### NOTE:

ECO pedal control is only for vehicles with an intelligent pedal (distance control assist).

#### ENGINE OUTPUT CHARACTERISTICS AFTER SWITCHING MODE

- Engine output characteristics after switching mode by operating the drive mode select switch are as follows.
  - After switching mode to a mode that engine output increase, engine output characteristics are changed by releasing the accelerator pedal.
  - After switching mode to a mode that engine output decreases, engine output characteristics are changed immediately.
- When an accelerator angle is constant, engine output characteristics are as follows.
  - SPORT > STANDARD > ECO > SNOW

Output characteristics of each mode

| Control mode | Engine output                           |
|--------------|---|
| SPORT        | Increase                                |
| STANDARD     | Normal                                  |
| ECO          | Decrease                                |
| SNOW         | Decrease (More reduction than ECO mode) |

# ON BOARD DIAGNOSTIC (OBD) SYSTEM

< SYSTEM DESCRIPTION >

[VQ37VHR FOR USA AND CANADA]

## ON BOARD DIAGNOSTIC (OBD) SYSTEM

### Diagnosis Description

INFOID:000000006882806

This system is an on board diagnostic system that records exhaust emission-related diagnostic information and detects a sensors/actuator-related malfunction. A malfunction is indicated by the malfunction indicator lamp (MIL) and stored in ECU memory as a DTC. The diagnostic information can be obtained with the diagnostic tool (GST: Generic Scan Tool).

### GST (Generic Scan Tool)

INFOID:000000006882807

When GST is connected with a data link connector equipped on the vehicle side, it will communicate with the control unit equipped in the vehicle and then enable various kinds of diagnostic tests. Refer to [EC-77. "Diagnosis Description"](#).

#### NOTE:

Service \$0A is not applied for regions where it is not mandated.

A  
EC  
C  
D  
E  
F  
G  
H  
I  
J  
K  
L  
M  
N  
O  
P

# DIAGNOSIS SYSTEM (ECM)

[VQ37VHR FOR USA AND CANADA]

< SYSTEM DESCRIPTION >

## DIAGNOSIS SYSTEM (ECM)

### DIAGNOSIS DESCRIPTION

#### DIAGNOSIS DESCRIPTION : 1st Trip Detection Logic and Two Trip Detection Logic

INFOID:000000006882808

When a malfunction is detected for the first time, 1st trip DTC and 1st trip Freeze Frame data are stored in the ECM memory. The MIL will not illuminate at this stage. <1st trip>

If the same malfunction is detected again during the next drive, the DTC and Freeze Frame data are stored in the ECM memory, and the MIL illuminates. The MIL illuminates at the same time when the DTC is stored. <2nd trip> The "trip" in the "Two Trip Detection Logic" means a driving mode in which self-diagnosis is performed during vehicle operation. Specific on board diagnostic items will cause the ECM to illuminate or blink the MIL, and store DTC and Freeze Frame data, even in the 1st trip, as shown below.

×: Applicable —: Not applicable

| Items   | MIL      |            |          |            | DTC                 |                     | 1st trip DTC        |                     |
|---|----------|------------|----------|------------|---------------------|---------------------|---------------------|---------------------|
|   | 1st trip |            | 2nd trip |            | 1st trip displaying | 2nd trip displaying | 1st trip displaying | 2nd trip displaying |
|   | Blinking | Illuminate | Blinking | Illuminate |                     |                     |                     |                     |
| Misfire (Possible three way catalyst damage) — DTC: P0300 - P0308 is being detected | ×        | —          | —        | —          | —                   | —                   | ×                   | —                   |
| Misfire (Possible three way catalyst damage) — DTC: P0300 - P0308 is being detected | —        | —          | ×        | —          | —                   | ×                   | —                   | —                   |
| One trip detection diagnoses (Refer to <a href="#">EC-117, "DTC Index."</a> )       | —        | ×          | —        | —          | ×                   | —                   | —                   | —                   |
| Except above  | —        | —          | —        | ×          | —                   | ×                   | ×                   | —                   |

#### DIAGNOSIS DESCRIPTION : DTC and Freeze Frame Data

INFOID:000000006882809

#### DTC AND 1ST TRIP DTC

The 1st trip DTC (whose number is the same as the DTC number) is displayed for the latest self-diagnostic result obtained. If the ECM memory was cleared previously, and the 1st trip DTC did not recur, the 1st trip DTC will not be displayed.

If a malfunction is detected during the 1st trip, the 1st trip DTC is saved in the ECM memory. The MIL will not light up (two trip detection logic). If the same malfunction is not detected in the 2nd trip (meeting the required driving pattern), the 1st trip DTC is cleared from the ECM memory. If the same malfunction is detected in the 2nd trip, both the 1st trip DTC and DTC are saved in the ECM memory and the MIL lights up. In other words, the DTC is stored in the ECM memory and the MIL lights up when the same malfunction occurs in two consecutive trips. If a 1st trip DTC is stored and a non-diagnostic operation is performed between the 1st and 2nd trips, only the 1st trip DTC will continue to be stored. For malfunctions that blink or light up the MIL during the 1st trip, the DTC and 1st trip DTC are stored in the ECM memory.

For malfunctions in which 1st trip DTCs are displayed, refer to [EC-117, "DTC Index."](#) These items are required by legal regulations to continuously monitor the system/component. In addition, the items monitored non-continuously are also displayed on CONSULT.

1st trip DTC is specified in Service \$07 of SAE J1979/ISO 15031-5. 1st trip DTC detection occurs without illuminating the MIL and therefore does not warn the driver of a malfunction.

When a 1st trip DTC is detected, check, print out or write down and erase (1st trip) DTC and Freeze Frame data as specified in Work Flow procedure Step 2, refer to [EC-139, "Work Flow."](#) Then perform DTC Confirmation Procedure or Component Function Check to try to duplicate the malfunction. If the malfunction is duplicated, the item requires repair.

#### FREEZE FRAME DATA AND 1ST TRIP FREEZE FRAME DATA

The ECM records the driving conditions such as fuel system status, calculated load value, engine coolant temperature, short term fuel trim, long term fuel trim, engine speed, vehicle speed, absolute throttle position, base fuel schedule and intake air temperature at the moment a malfunction is detected.

Data which are stored in the ECM memory, along with the 1st trip DTC, are called 1st trip freeze frame data. The data, stored together with the DTC data, are called freeze frame data and displayed on CONSULT or GST. The 1st trip freeze frame data can only be displayed on the CONSULT screen.

# DIAGNOSIS SYSTEM (ECM)

[VQ37VHR FOR USA AND CANADA]

## < SYSTEM DESCRIPTION >

Only one set of freeze frame data (either 1st trip freeze frame data or freeze frame data) can be stored in the ECM. 1st trip freeze frame data is stored in the ECM memory along with the 1st trip DTC. There is no priority for 1st trip freeze frame data and it is updated each time a different 1st trip DTC is detected. However, once freeze frame data (2nd trip detection/MIL on) is stored in the ECM memory, 1st trip freeze frame data is no longer stored. Remember, only one set of freeze frame data can be stored in the ECM. The ECM has the following priorities to update the data.

| Priority | Items                      |  |
|----------|----------------------------|--|
| 1        | Freeze frame data          | Misfire — DTC: P0300 - P0308<br>Fuel Injection System Function — DTC: P0171, P0172, P0174, P0175 |
| 2        |                            | Except the above items   |
| 3        | 1st trip freeze frame data |  |

For example, the EGR malfunction (Priority: 2) was detected and the freeze frame data was saved in the 2nd trip. After that when the misfire (Priority: 1) is detected in another trip, the freeze frame data will be updated from the EGR malfunction to the misfire. The 1st trip freeze frame data is updated each time a different malfunction is detected. There is no priority for 1st trip freeze frame data. However, once freeze frame data is stored in the ECM memory, 1st trip freeze data is no longer stored (because only one freeze frame data or 1st trip freeze frame data can be stored in the ECM). If freeze frame data is stored in the ECM memory and freeze frame data with the same priority occurs later, the first (original) freeze frame data remains unchanged in the ECM memory.

Both 1st trip freeze frame data and freeze frame data (along with the DTCs) are cleared when the ECM memory is erased.

## DIAGNOSIS DESCRIPTION : Counter System

INFOID:000000007202376

### RELATIONSHIP BETWEEN MIL, 1ST TRIP DTC, DTC, AND DETECTABLE ITEMS

- When a malfunction is detected for the first time, the 1st trip DTC and the 1st trip freeze frame data are stored in the ECM memory.
- When the same malfunction is detected in two consecutive trips, the DTC and the freeze frame data are stored in the ECM memory, and the MIL will come on.
- The MIL will turn OFF after the vehicle is driven 3 times (driving pattern B) with no malfunction. The drive is counted only when the recorded driving pattern is met (as stored in the ECM). If another malfunction occurs while counting, the counter will reset.
- The DTC and the freeze frame data will be stored until the vehicle is driven 40 times (driving pattern A) without the same malfunction recurring (except for Misfire and Fuel Injection System). For Misfire and Fuel Injection System, the DTC and freeze frame data will be stored until the vehicle is driven 80 times (driving pattern C) without the same malfunction recurring. The "TIME" in "SELF-DIAGNOSTIC RESULTS" mode of CONSULT will count the number of times the vehicle is driven.
- The 1st trip DTC is not displayed when the self-diagnosis results in OK for the 2nd trip.

### COUNTER SYSTEM CHART

| Items                               | Fuel Injection System | Misfire           | Other          |
|-------------------------------------|-----------------------|-------------------|----------------|
| MIL (turns OFF)                     | 3 (pattern B)         | 3 (pattern B)     | 3 (pattern B)  |
| DTC, Freeze Frame Data (no display) | 80 (pattern C)        | 80 (pattern C)    | 40 (pattern A) |
| 1st Trip DTC (clear)                | 1 (pattern C), *1     | 1 (pattern C), *1 | 1 (pattern B)  |
| 1st Trip Freeze Frame Data (clear)  | *1, *2                | *1, *2            | 1 (pattern B)  |

For details about patterns B and C under "Fuel Injection System" and "Misfire", see "EXPLANATION FOR DRIVING PATTERNS FOR "MISFIRE <EXHAUST QUALITY DETERIORATION>", "FUEL INJECTION SYSTEM".

For details about patterns A and B under Other, see "EXPLANATION FOR DRIVING PATTERNS FOR "MISFIRE <EXHAUST QUALITY DETERIORATION>", "FUEL INJECTION SYSTEM".

- \*1: Clear timing is at the moment OK is detected.
- \*2: Clear timing is when the same malfunction is detected in the 2nd trip.

Relationship Between MIL, DTC, 1st Trip DTC and Driving Patterns for "Misfire <Exhaust Quality Deterioration>", "Fuel Injection System"

# DIAGNOSIS SYSTEM (ECM)

[VQ37VHR FOR USA AND CANADA]

< SYSTEM DESCRIPTION >

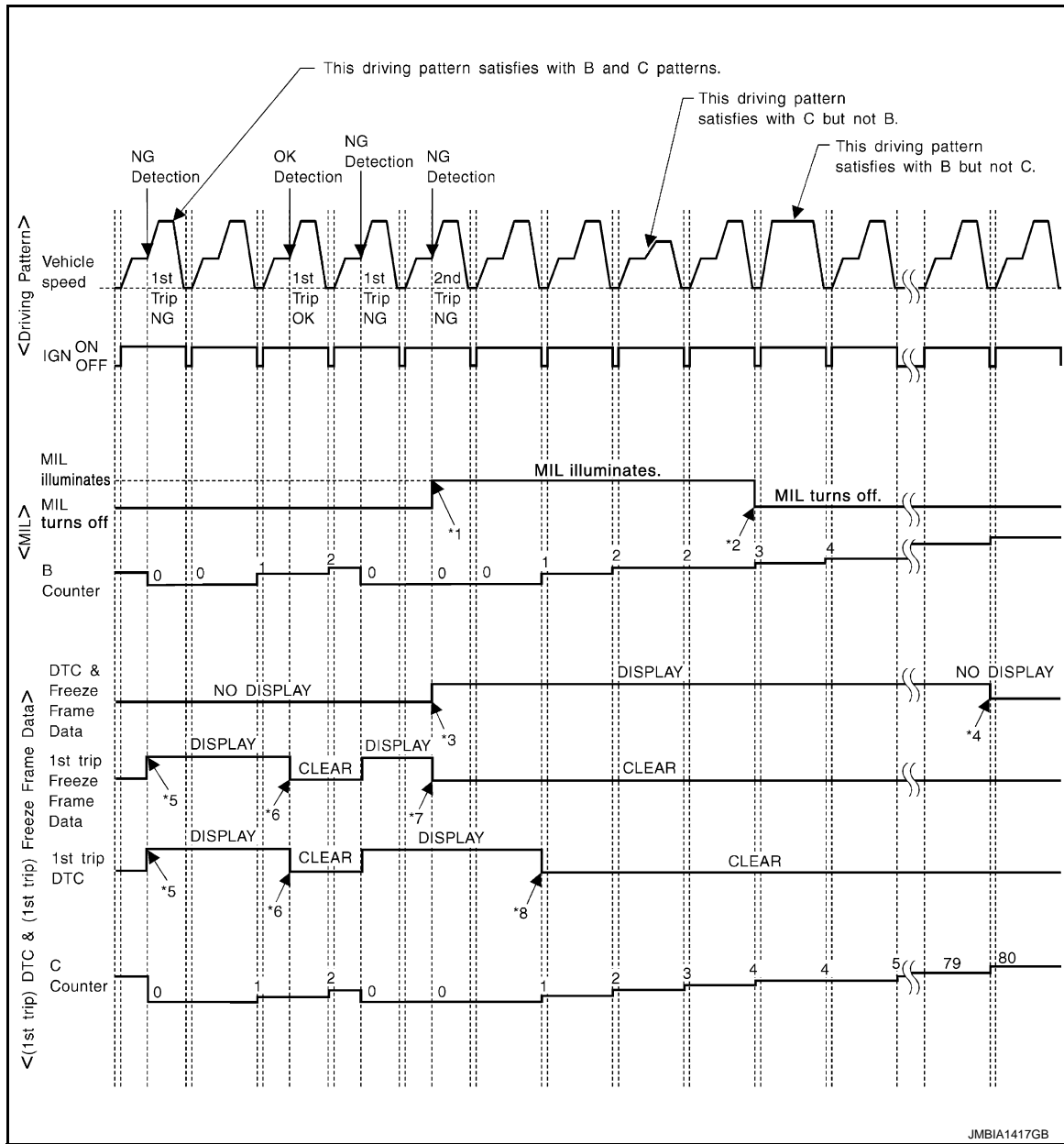

JMBIA1417GB

- \*1: When the same malfunction is detected in two consecutive trips, MIL will light up.
- \*2: MIL will turn OFF after vehicle is driven 3 times (pattern B) without any malfunctions.
- \*3: When the same malfunction is detected in two consecutive trips, the DTC and the freeze frame data will be stored in ECM.
- \*4: The DTC and the freeze frame data will not be displayed any longer after vehicle is driven 80 times (pattern C) without the same malfunction. (The DTC and the freeze frame data still remain in ECM.)
- \*5: When a malfunction is detected for the first time, the 1st trip DTC and the 1st trip freeze frame data will be cleared at the moment OK is detected.
- \*6: The 1st trip DTC and the 1st trip freeze frame data will be cleared at the moment OK is detected.
- \*7: When the same malfunction is detected in the 2nd trip, the 1st trip freeze frame data will be cleared.
- \*8: 1st trip DTC will be cleared when vehicle is driven once (pattern C) without the same malfunction after DTC is stored in ECM.

Explanation for Driving Patterns for "Misfire <Exhaust Quality Deterioration>", "Fuel Injection System"

Driving Pattern B

Refer to [EC-82. "DIAGNOSIS DESCRIPTION : Driving Pattern"](#).



# DIAGNOSIS SYSTEM (ECM)

[VQ37VHR FOR USA AND CANADA]

## < SYSTEM DESCRIPTION >

### Driving Pattern C

Refer to [EC-82. "DIAGNOSIS DESCRIPTION : Driving Pattern"](#).

Example:

If the stored freeze frame data is as per the following:

Engine speed: 850 rpm, Calculated load value: 30%, Engine coolant temperature: 80°C (176°F)

To be satisfied with driving pattern C, the vehicle should run under the following conditions:

Engine speed: 475 – 1,225 rpm, Calculated load value: 27 – 33%, Engine coolant temperature: more than 70°C (158°F)

Relationship Between MIL, DTC, 1st Trip DTC and Driving Patterns Except For “Misfire <Exhaust Quality Deterioration>”, “Fuel Injection System”

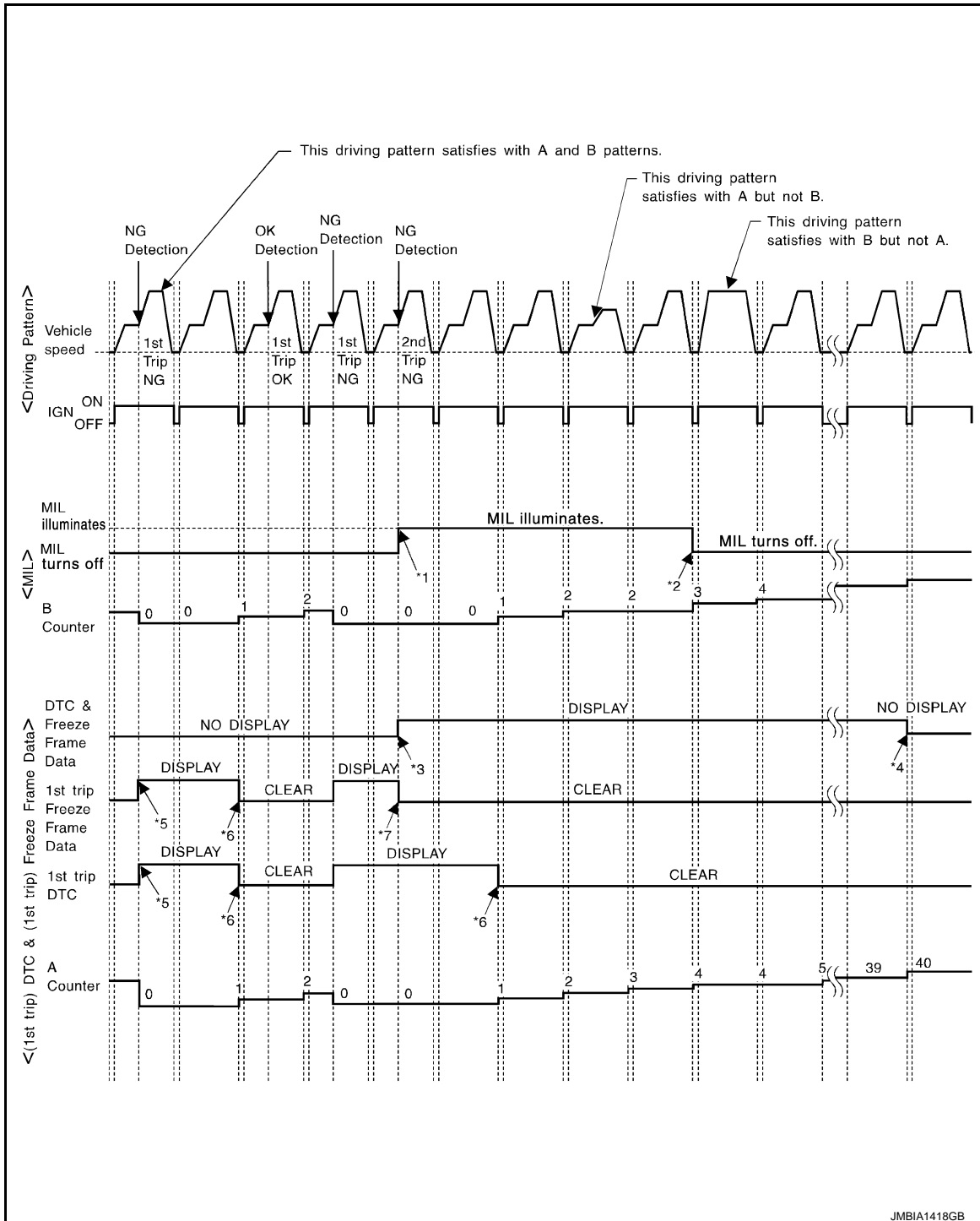

JMBIA1418GB

# DIAGNOSIS SYSTEM (ECM)

[VQ37VHR FOR USA AND CANADA]

## < SYSTEM DESCRIPTION >

- \*1: When the same malfunction is detected in two consecutive trips, MIL will light up.
- \*2: MIL will turn OFF after vehicle is driven 3 times (pattern B) without any malfunctions.
- \*3: When the same malfunction is detected in two consecutive trips, the DTC and the freeze frame data will be stored in ECM.
- \*4: The DTC and the freeze frame data will not be displayed any longer after vehicle is driven 40 times (pattern A) without the same malfunction. (The DTC and the freeze frame data still remain in ECM.)
- \*5: When a malfunction is detected for the first time, the 1st trip DTC and the 1st trip freeze frame data will be stored in ECM.
- \*6: 1st trip DTC will be cleared after vehicle is driven once (pattern B) without the same malfunction.
- \*7: When the same malfunction is detected in the 2nd trip, the 1st trip freeze frame data will be cleared.

Explanation for Driving Patterns Except for “Misfire <Exhaust Quality Deterioration>”, “Fuel Injection System”

Driving Pattern A

Refer to [EC-82, "DIAGNOSIS DESCRIPTION : Driving Pattern"](#).

Driving Pattern B

Refer to [EC-82, "DIAGNOSIS DESCRIPTION : Driving Pattern"](#).

## DIAGNOSIS DESCRIPTION : Driving Pattern

INFOID:000000007202377

### **CAUTION:**

**Always drive at a safe speed.**

### DRIVING PATTERN A

Driving pattern A means a trip satisfying the following conditions.

- Engine speed reaches 400 rpm or more.
- Engine coolant temperature rises by 20°C (32°F) or more after starting the engine.
- Engine coolant temperature reaches 70°C (158°F) or more.
- The ignition switch is turned from ON to OFF.

#### **NOTE:**

- When the same malfunction is detected regardless of driving conditions, reset the counter of driving pattern A.
- When the above conditions are satisfied without detecting the same malfunction, reset the counter of driving pattern A.

### DRIVING PATTERN B

Driving pattern B means a trip satisfying the following conditions.

- Engine speed reaches 400 rpm or more.
- Engine coolant temperature reaches 70°C (158°F) or more.
- Vehicle speed of 70 – 120 km/h (44 – 75 MPH) is maintained for 60 seconds or more under the control of closed loop.
- Vehicle speed of 30 – 60 km/h (19 – 37 MPH) is maintained for 10 seconds or more under the control of closed loop.
- Under the closed loop control condition, the following state reaches 12 seconds or more in total: Vehicle speed of 4 km/h (2 MPH) or less with idling condition.
- The state of driving at 10 km/h (7 MPH) or more reaches 10 minutes or more in total.
- A lapse of 22 minutes or more after engine start.

#### **NOTE:**

- Drive the vehicle at a constant velocity.
- When the same malfunction is detected regardless of driving conditions, reset the counter of driving pattern B.
- When the above conditions are satisfied without detecting the same malfunction, reset the counter of driving pattern B.

### DRIVING PATTERN C

Driving pattern C means operating vehicle as per the following:

The following conditions should be satisfied at the same time:

Engine speed: (Engine speed in the freeze frame data)  $\pm 375$  rpm

# DIAGNOSIS SYSTEM (ECM)

[VQ37VHR FOR USA AND CANADA]

## < SYSTEM DESCRIPTION >

Calculated load value: (Calculated load value in the freeze frame data) x (1±0.1) [%]

Engine coolant temperature condition:

- When the freeze frame data shows lower than 70°C (158°F), engine coolant temperature should be lower than 70°C (158°F).
- When the freeze frame data shows higher than or equal to 70°C (158°F), engine coolant temperature should be higher than or equal to 70°C (158°F).

### NOTE:

- When the same malfunction is detected regardless of the above vehicle conditions, reset the counter of driving pattern C.
- When the above conditions are satisfied without detecting the same malfunction, reset the counter of driving pattern C.
- The 1st trip DTC will be cleared when C counter is counted once without the same malfunction after DTC is stored in ECM.

## DRIVING PATTERN D

Driving pattern D means a trip satisfying the following conditions.

- The state of driving at 40 km/h (25 MPH) reaches 300 seconds or more in total.
- Idle speed lasts 30 seconds or more.
- A lapse of 600 seconds or more after engine start.

### NOTE:

- When the same malfunction is detected regardless of driving conditions, reset the counter of driving pattern D.
- When the above conditions are satisfied without detecting the same malfunction, reset the counter of driving pattern D.

## DIAGNOSIS DESCRIPTION : System Readiness Test (SRT) Code

INFOID:000000007202378

System Readiness Test (SRT) code is specified in Service \$01 of SAE J1979/ISO 15031-5.

As part of an enhanced emissions test for Inspection & Maintenance (I/M), certain states require the status of SRT be used to indicate whether the ECM has completed self-diagnosis of major emission systems and components. Completion must be verified in order for the emissions inspection to proceed.

If a vehicle is rejected for a State emissions inspection due to one or more SRT items indicating "INCMP", use the information in this Service Manual to set the SRT to "CMPLT".

In most cases the ECM will automatically complete its self-diagnosis cycle during normal usage, and the SRT status will indicate "CMPLT" for each application system. Once set as "CMPLT", the SRT status remains "CMPLT" until the self-diagnosis memory is erased.

Occasionally, certain portions of the self-diagnostic test may not be completed as a result of the customer's normal driving pattern; the SRT will indicate "INCMP" for these items.

### NOTE:

The SRT will also indicate "INCMP" if the self-diagnosis memory is erased for any reason or if the ECM memory power supply is interrupted for several hours.

If, during the state emissions inspection, the SRT indicates "CMPLT" for all test items, the inspector will continue with the emissions test. However, if the SRT indicates "INCMP" for one or more of the SRT items the vehicle is returned to the customer untested.

### NOTE:

If permanent DTC is stored or MIL illuminates during the state emissions inspection, the vehicle is also returned to the customer untested even though the SRT indicates "CMPLT" for all test items. Therefore, it is important to check SRT ("CMPLT"), DTC (No DTCs) and permanent DTC (NO permanent DTCs) before the inspection.

## SRT SET TIMING

SRT is set as "CMPLT" after self-diagnosis has been performed one or more times. Completion of SRT is done regardless of whether the result is OK or NG. The set timing is different between OK and NG results and is shown in the table below.

# DIAGNOSIS SYSTEM (ECM)

< SYSTEM DESCRIPTION >

[VQ37VHR FOR USA AND CANADA]

| Self-diagnosis result |        | Example           |                |         |              |                        |        |     |
|-----------------------|--------|-------------------|----------------|---------|--------------|------------------------|--------|-----|
|                       |        | Diagnosis         | Ignition cycle |         |              |                        |        |     |
|                       |        |                   | ← ON →         | OFF     | ← ON →       | OFF                    | ← ON → | OFF |
| All OK                | Case 1 | P0400             | OK (1)         | — (1)   | OK (2)       | — (2)                  |        |     |
|                       |        | P0402             | OK (1)         | — (1)   | — (1)        | OK (2)                 |        |     |
|                       |        | P1402             | OK (1)         | OK (2)  | — (2)        | — (2)                  |        |     |
|                       |        | SRT of EGR        | “CMPLT”        | “CMPLT” | “CMPLT”      | “CMPLT”                |        |     |
|                       | Case 2 | P0400             | OK (1)         | — (1)   | — (1)        | — (1)                  |        |     |
|                       |        | P0402             | — (0)          | — (0)   | OK (1)       | — (1)                  |        |     |
|                       |        | P1402             | OK (1)         | OK (2)  | — (2)        | — (2)                  |        |     |
|                       |        | SRT of EGR        | “INCMP”        | “INCMP” | “CMPLT”      | “CMPLT”                |        |     |
| NG exists             | Case 3 | P0400             | OK             | OK      | —            | —                      |        |     |
|                       |        | P0402             | —              | —       | —            | —                      |        |     |
|                       |        | P1402             | NG             | —       | NG           | NG<br>(Consecutive NG) |        |     |
|                       |        | (1st trip)<br>DTC | 1st trip DTC   | —       | 1st trip DTC | DTC<br>(= MIL ON)      |        |     |
|                       |        | SRT of EGR        | “INCMP”        | “INCMP” | “INCMP”      | “CMPLT”                |        |     |

OK: Self-diagnosis is carried out and the result is OK.

NG: Self-diagnosis is carried out and the result is NG.

—: Self-diagnosis is not carried out.

When all SRT related self-diagnoses show OK results in a single cycle (Ignition OFF-ON-OFF), the SRT will indicate “CMPLT”. → Case 1 above

When all SRT related self-diagnoses show OK results through several different cycles, the SRT will indicate “CMPLT” at the time the respective self-diagnoses have at least one OK result. → Case 2 above

If one or more SRT related self-diagnoses show NG results in 2 consecutive cycles, the SRT will also indicate “CMPLT”. → Case 3 above

The table above shows that the minimum number of cycles for setting SRT as “INCMP” is the number one (1) for each self-diagnosis (Case 1 & 2) or the number two (2) for one of self-diagnoses (Case 3). However, in preparation for the state emissions inspection, it is unnecessary for each self-diagnosis to be executed twice (Case 3) for the following reasons:

- The SRT will indicate “CMPLT” at the time the respective self-diagnoses have one (1) OK result.
- The emissions inspection requires “CMPLT” of the SRT only with OK self-diagnosis results.
- During SRT driving pattern, the 1st trip DTC (NG) is detected prior to “CMPLT” of SRT and the self-diagnosis memory must be erased from the ECM after repair.
- If the 1st trip DTC is erased, all the SRT will indicate “INCMP”.

**NOTE:**

SRT can be set as “CMPLT” together with the DTC(s). Therefore, DTC check must always be carried out prior to the state emission inspection even though the SRT indicates “CMPLT”.

## DIAGNOSIS DESCRIPTION : Permanent Diagnostic Trouble Code (Permanent DTC)

INFOID:000000007202115

Permanent DTC is defined in SAE J1979/ISO 15031-5 Service \$0A.

ECM stores a DTC issuing a command of turning on MIL as a permanent DTC and keeps storing the DTC as a permanent DTC until ECM judges that there is no presence of malfunction.

Permanent DTCs cannot be erased by using the Erase function of CONSULT or Generic Scan Tool (GST) and by disconnecting the battery to shut off power to ECM. This prevents a vehicle from passing the state emission inspection without repairing a malfunctioning part.

When not passing the state emission inspection due to more than one permanent DTC, permanent DTCs should be erased, referring to this manual.

**NOTE:**

- The important items in state emission inspection are that MIL is not ON, SRT test items are set, and permanent DTCs are not included.
- Permanent DTCs do not apply for regions that permanent DTCs are not regulated by law.

# DIAGNOSIS SYSTEM (ECM)

[VQ37VHR FOR USA AND CANADA]

< SYSTEM DESCRIPTION >

## PERMANENT DTC SET TIMING

The setting timing of permanent DTC is stored in ECM with the lighting of MIL when a DTC is confirmed.

## DIAGNOSIS DESCRIPTION : Malfunction Indicator Lamp (MIL)

INFOID:000000006882813

When emission related ECU detects a malfunction in the emission control systems components and/or the powertrain control components (which affect vehicle emissions), it turns on/blinks MIL to inform the driver that a malfunction has been detected.

1. The MIL illuminates when ignition switch is turned ON (engine is not running).

### NOTE:

Check the MIL circuit if MIL does not illuminate. Refer to [EC-524, "Component Function Check"](#).

2. When the engine is started, the MIL should go off.

### NOTE:

If MIL continues to illuminate/blink, perform self-diagnoses and inspect/repair accordingly because an emission related ECU has detected a malfunction in the emission control systems components and/or the powertrain control components (which affect vehicle emissions).

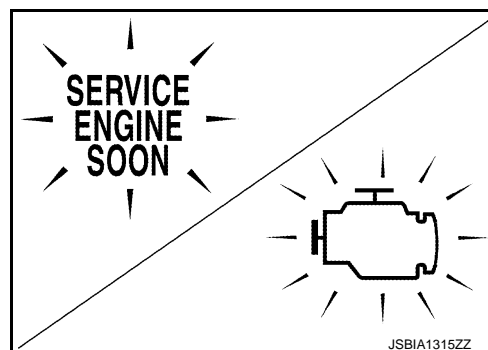

## On Board Diagnosis Function

INFOID:000000006882814

### ON BOARD DIAGNOSIS ITEM

The on board diagnostic system has the following functions.

| Diagnostic test mode                          | Function   |
|---|--|
| Bulb check                                    | MIL can be checked.  |
| SRT status                                    | ECM can read if SRT codes are set.   |
| Malfunction warning                           | If ECM detects a malfunction, it illuminates or blinks MIL to inform the driver that a malfunction has been detected.            |
| Self-diagnostic results                       | DTCs or 1st trip DTCs stored in ECM can be read.   |
| Accelerator pedal released position learning  | ECM can learn the accelerator pedal released position. Refer to <a href="#">EC-147, "Description"</a> .                          |
| Throttle valve closed position learning       | ECM can learn the throttle valve closed position. Refer to <a href="#">EC-147, "Description"</a> .                               |
| Idle air volume learning                      | ECM can learn the idle air volume. Refer to <a href="#">EC-149, "Description"</a> .  |
| VVEL control shaft position sensor adjustment | The initial position of the VVEL control shaft position sensor can be adjusted. Refer to <a href="#">EC-151, "Description"</a> . |

## BLUB CHECK MODE

### Description

This function allows damage inspection in the MIL bulb (blown, open circuit, etc.).

### Operation Procedure

1. Turn ignition switch ON.
2. The MIL on the instrument panel should stay ON.  
If it remains OFF, check MIL circuit. Refer to [EC-524, "Diagnosis Procedure"](#).

## SRT STATUS MODE

### Description

This function allows to read if ECM has completed the self-diagnoses of major emission control systems and components. For SRT, refer to [EC-83, "DIAGNOSIS DESCRIPTION : System Readiness Test \(SRT\) Code"](#).

### Operation Procedure

1. Turn ignition switch ON and wait 20 seconds.
2. SRT status is indicated as shown blow.
  - ECM continues to illuminate MIL if all SRT codes are set.

# DIAGNOSIS SYSTEM (ECM)

[VQ37VHR FOR USA AND CANADA]

## < SYSTEM DESCRIPTION >

- ECM blinks MIL for about 10 seconds if all SRT codes are not set.

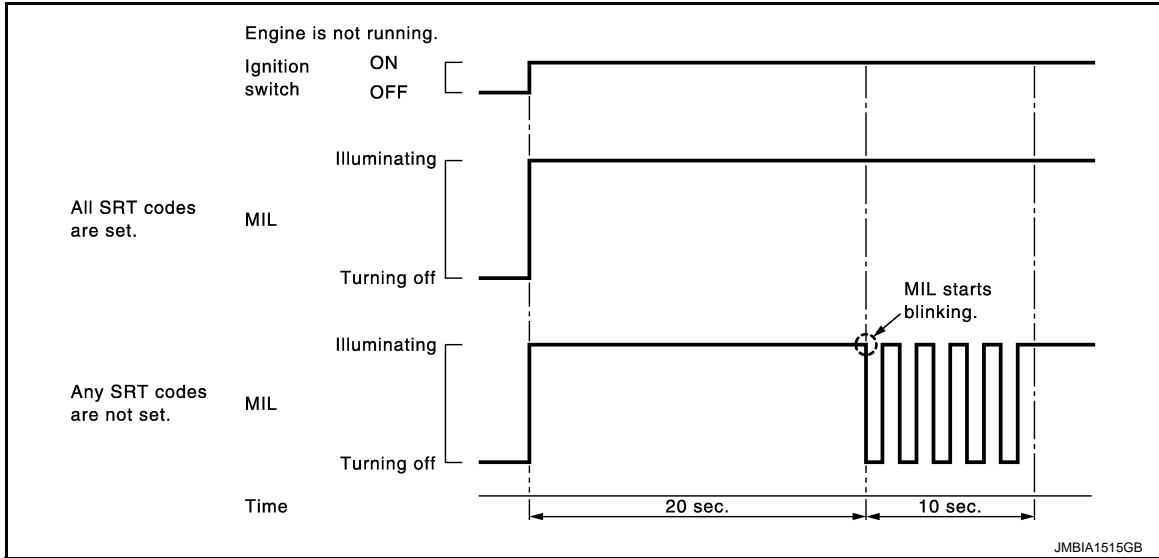

## MALFUNCTION WARNING MODE

### Description

In this function ECM turns on or blinks MIL when it detects a malfunction in the emission control system components and/or the powertrain control components (which affect vehicle emissions) to inform the driver that a malfunction has been detected.

### Operation Procedure

1. Turn ignition switch ON.
2. Check that MIL illuminates.  
If it remains OFF, check MIL circuit. Refer to [EC-524, "Diagnosis Procedure"](#).
3. Start engine and let it idle.
  - For two trip detection logic diagnoses, ECM turns on MIL when it detects the same malfunction twice in the two consecutive driving cycles.
  - For 1st trip detection logic diagnoses, ECM turns on MIL when it detects a malfunction in one driving cycle.
  - ECM blinks MIL when it detects a malfunction that may damage the three way catalyst (misfire).

## SELF-DIAGNOSTIC RESULTS MODE

### Description

This function allows to indicate DTCs or 1st trip DTCs stored in ECM according to the number of times MIL is blinking.

### How to Set Self-diagnostic Results Mode

#### NOTE:

- It is better to count the time accurately with a clock.
  - It is impossible to switch the diagnostic mode when an accelerator pedal position sensor circuit has a malfunction.
  - After ignition switch is turned off, ECM is always released from the "self-diagnostic results" mode.
1. Confirm that accelerator pedal is fully released, turn ignition switch ON and wait 3 seconds.
  2. Repeat the following procedure quickly five times within 5 seconds.
    - Fully depress the accelerator pedal.
    - Fully release the accelerator pedal.
  3. Wait 7 seconds, fully depress the accelerator pedal and keep it depressed for approx. 10 seconds until the MIL starts blinking.

#### NOTE:

Do not release the accelerator pedal for 10 seconds if MIL starts blinking during this period. This blinking is displaying SRT status and is continued for another 10 seconds.

4. Fully release the accelerator pedal.  
ECM has entered to self-diagnostic results mode.

# DIAGNOSIS SYSTEM (ECM)

[VQ37VHR FOR USA AND CANADA]

## < SYSTEM DESCRIPTION >

### NOTE:

Wait until the same DTC (or 1st trip DTC) appears to completely confirm all DTCs.

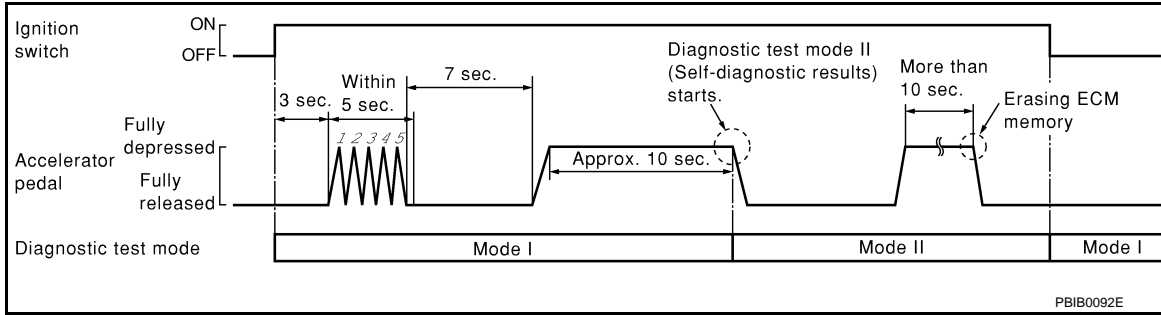

### How to Read Self-diagnostic Results

The DTC and 1st trip DTC are indicated by the number of blinks of the MIL as shown below.

The DTC and 1st trip DTC are displayed at the same time. If the MIL does not illuminate in diagnostic test mode I (Malfunction warning), all displayed items are 1st trip DTCs. If only one code is displayed when the MIL illuminates in "malfunction warning" mode, it is a DTC; if two or more codes are displayed, they may be either DTCs or 1st trip DTCs. DTC No. is same as that of 1st trip DTC. These unidentified codes can be identified by using the CONSULT or GST. A DTC will be used as an example for how to read a code.

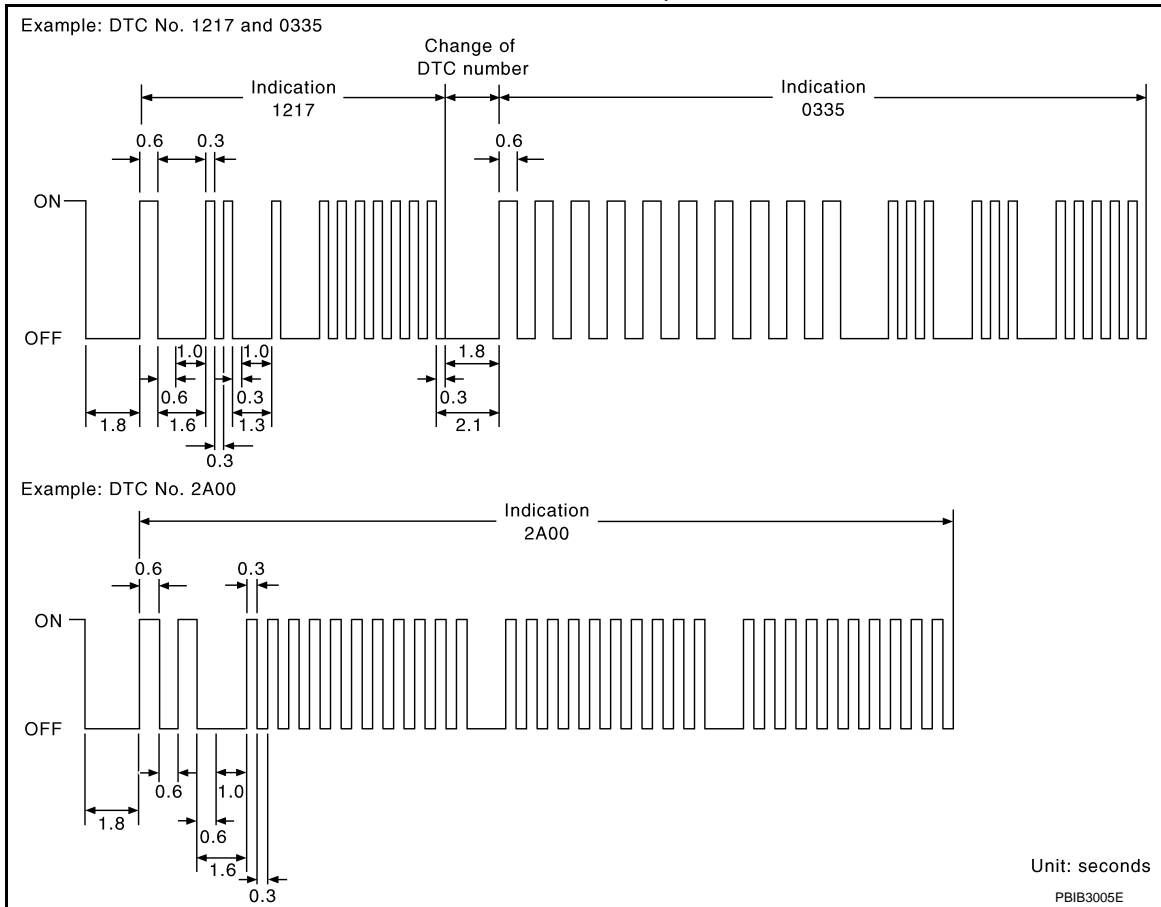

A particular trouble code can be identified by the number of four-digit numeral flashes per the following.

| Number  | 0  | 1 | 2 | 3 | 4 | 5 | 6 | 7 | 8 | 9 | A  | B  | C  | D  | E  | F  |
|---------|----|---|---|---|---|---|---|---|---|---|----|----|----|----|----|----|
| Flashes | 10 | 1 | 2 | 3 | 4 | 5 | 6 | 7 | 8 | 9 | 11 | 12 | 13 | 14 | 15 | 16 |

The length of time the 1,000th-digit numeral flashes on and off is 1.2 seconds consisting of an ON (0.6-seconds) - OFF (0.6-seconds) cycle.

The 100th-digit numeral and lower digit numerals consist of a 0.3-seconds ON and 0.3-seconds OFF cycle.

A change from one digit numeral to another occurs at an interval of 1.0-second OFF. In other words, the later numeral appears on the display 1.3 seconds after the former numeral has disappeared.

A change from one trouble code to another occurs at an interval of 1.8-seconds OFF.

# DIAGNOSIS SYSTEM (ECM)

[VQ37VHR FOR USA AND CANADA]

## < SYSTEM DESCRIPTION >

In this way, all the detected malfunctions are classified by their DTC numbers. The DTC 0000 refers to no malfunction. Refer to [EC-117, "DTC Index"](#).

### How to Erase Self-diagnostic Results

By performing this procedure, ECM memory is erased and the following diagnostic information is erased as well.

- Diagnostic trouble codes
- 1st trip diagnostic trouble codes
- Freeze frame data
- 1st trip freeze frame data
- System readiness test (SRT) codes
- Test values

#### **NOTE:**

Also, if a battery terminal is disconnected, ECM memory is erased and the diagnostic information as listed above is erased. (The amount of time required for erasing may vary from a few seconds to several hours.)

1. Turn ignition switch OFF and wait at least 10 seconds.
2. Turn ignition switch ON.
3. Turn ignition switch OFF and wait at least 10 seconds.
4. Turn ignition switch ON.
5. Set ECM in self-diagnostic results.
6. The diagnostic information has been erased from the backup memory in the ECM.  
Fully depress the accelerator pedal and keep it depressed for more than 10 seconds.
7. Fully release the accelerator pedal, and confirm the DTC 0000 is displayed.

## CONSULT Function

INFOID:000000006882815

### FUNCTION

| Diagnostic test mode           | Function  |
|--------------------------------|---|
| Work support                   | This mode enables a technician to adjust some devices faster and more accurately by following the indications on the CONSULT unit.      |
| Self-diagnostic results        | Self-diagnostic results such as 1st trip DTC, DTCs and 1st trip freeze frame data or freeze frame data can be read and erased quickly.* |
| Data monitor                   | Input/Output data in the ECM can be read.   |
| CAN diagnostic support monitor | The results of transmit/receive diagnosis of CAN communication can be read.   |
| Active test                    | Diagnostic Test Mode in which CONSULT drives some actuators apart from the ECMs and also shifts some parameters in a specified range.   |
| DTC & SRT confirmation         | The status of system monitoring tests and the self-diagnosis status/results can be confirmed.   |
| Function test                  | This mode is used to inform customers when their vehicle requires periodic maintenance.   |
| ECU part number                | ECM part number can be read.  |

\*: The following emission-related diagnostic information is cleared when the ECM memory is erased.

- Diagnostic trouble codes
- 1st trip diagnostic trouble codes
- Freeze frame data
- 1st trip freeze frame data
- System readiness test (SRT) codes
- Test values

### WORK SUPPORT MODE

Work Item



# DIAGNOSIS SYSTEM (ECM)

< SYSTEM DESCRIPTION >

[VQ37VHR FOR USA AND CANADA]

| WORK ITEM             | CONDITION  | USAGE   |
|-----------------------|--|---|
| IDLE AIR VOL LEARN    | <ul style="list-style-type: none"> <li>The idle air volume that keeps the engine within the specified range is memorized in ECM.</li> </ul>  | When learning the idle air volume                 |
| EVAP SYSTEM CLOSE     | <p>Close the EVAP canister vent control valve in order to make evap system close under the following conditions.</p> <ul style="list-style-type: none"> <li>Ignition switch ON</li> <li>Engine not running</li> <li>Ambient temperature is above 0°C (32°F).</li> <li>No vacuum and no high pressure in EVAP system</li> <li>Fuel tank temp. is more than 0°C (32°F).</li> <li>Within 10 minutes after starting "EVAP SYSTEM CLOSE"</li> <li>When trying to execute "EVAP SYSTEM CLOSE" Under the condition except above, CONSULT will discontinue it and display appropriate instruction.</li> </ul> <p><b>NOTE:</b><br/>When starting engine, CONSULT may display "Battery voltage is low. Charge battery", even when using a charged battery.</p> | When detecting EVAP vapor leak in the EVAP system |
| FUEL PRESSURE RELEASE | <ul style="list-style-type: none"> <li>Fuel pump will stop by touching "START" during idling. Crank a few times after engine stalls.</li> </ul>  | When releasing fuel pressure from fuel line       |
| SELF-LEARNING CONT    | <ul style="list-style-type: none"> <li>The coefficient of self-learning control mixture ratio returns to the original coefficient.</li> </ul>  | When clearing mixture ratio self-learning value   |
| TARGET IDLE RPM ADJ*  | <ul style="list-style-type: none"> <li>Idle condition</li> </ul>   | When setting target idle speed                    |
| TARGET IGN TIM ADJ*   | <ul style="list-style-type: none"> <li>Idle condition</li> </ul>   | When adjusting target ignition timing             |
| VIN REGISTRATION      | <ul style="list-style-type: none"> <li>In this mode, VIN is registered in ECM.</li> </ul>  | When registering VIN in ECM                       |
| CLSD THL POS LEARN    | <ul style="list-style-type: none"> <li>Ignition switch ON and engine stopped.</li> </ul>   | When learning the throttle valve closed position  |
| VVEL POS SEN ADJ PREP | <ul style="list-style-type: none"> <li>Use this item only when replacing VVEL actuator sub assembly.</li> <li>Ignition on and engine stopped.</li> </ul>   | When adjusting VVEL control shaft position sensor |

\*: This function is not necessary in the usual service procedure.

## SELF-DIAG RESULTS MODE

### Self Diagnostic Item

Regarding items of DTC and 1st trip DTC, refer to [EC-117, "DTC Index"](#).

### How to Read DTC and 1st Trip DTC

DTCs and 1st trip DTCs related to the malfunction are displayed in "Self-diag results".

- When ECM detects a 1st trip DTC, "1t" is displayed for "TIME".
- When ECM has detected a current DTC, "0" is displayed for "TIME".
- If "TIME" is neither "0" nor "1t", the DTC occurred in the past and ECM shows the number of times the vehicle has been driven since the last detection of the DTC.

### How to Erase DTC and 1st Trip DTC

#### NOTE:

- If the ignition switch stays ON after repair work, be sure to turn ignition switch OFF once. Wait at least 10 seconds and then turn it ON (engine stopped) again.
- If the DTC is not for A/T related items (see [EC-117, "DTC Index"](#)), skip step 1.
  - Erase DTC in TCM. Refer to [TM-59, "Diagnosis Description"](#).
  - Select "ENGINE" with CONSULT.
  - Select "SELF-DIAG RESULTS".
  - Touch "ERASE". (DTC in ECM will be erased.)

### Freeze Frame Data and 1st Trip Freeze Frame Data

| Freeze frame data item*   | Description   |
|---------------------------|---|
| DIAG TROUBLE CODE [PXXXX] | <ul style="list-style-type: none"> <li>The engine control component part/control system has a trouble code that is displayed as PXXXX. (Refer to <a href="#">EC-117, "DTC Index"</a>.)</li> </ul> |
| CAL/LD VALUE [%]          | <ul style="list-style-type: none"> <li>The calculated load value at the moment a malfunction is detected is displayed.</li> </ul>   |

# DIAGNOSIS SYSTEM (ECM)

[VQ37VHR FOR USA AND CANADA]

## < SYSTEM DESCRIPTION >

| Freeze frame data item*      | Description   |
|------------------------------|---|
| COOLANT TEMP [°C] or [°F]    | <ul style="list-style-type: none"> <li>The engine coolant temperature at the moment a malfunction is detected is displayed.</li> </ul>  |
| L-FUEL TRM-B1 [%]            | <ul style="list-style-type: none"> <li>"Long-term fuel trim" at the moment a malfunction is detected is displayed.</li> <li>The long-term fuel trim indicates much more gradual feedback compensation to the base fuel schedule than short-term fuel trim.</li> </ul>   |
| L-FUEL TRM-B2 [%]            |   |
| S-FUEL TRM-B1 [%]            | <ul style="list-style-type: none"> <li>"Short-term fuel trim" at the moment a malfunction is detected is displayed.</li> <li>The short-term fuel trim indicates dynamic or instantaneous feedback compensation to the base fuel schedule.</li> </ul>  |
| S-FUEL TRM-B2 [%]            |   |
| ENGINE SPEED [rpm]           | <ul style="list-style-type: none"> <li>The engine speed at the moment a malfunction is detected is displayed</li> </ul>   |
| VEHICL SPEED [km/h] or [mph] | <ul style="list-style-type: none"> <li>The vehicle speed at the moment a malfunction is detected is displayed</li> </ul>  |
| ABSOL TH-P/S [%]             | <ul style="list-style-type: none"> <li>The throttle valve opening angle at the moment a malfunction is detected is displayed</li> </ul>   |
| B/FUEL SCHDL [msec]          | <ul style="list-style-type: none"> <li>The base fuel schedule at the moment a malfunction is detected is displayed</li> </ul>   |
| INT/A TEMP SE [°C] or [°F]   | <ul style="list-style-type: none"> <li>The intake air temperature at the moment a malfunction is detected is displayed</li> </ul>   |
| FUEL SYS-B1                  | <ul style="list-style-type: none"> <li>"Fuel injection system status" at the moment a malfunction is detected is displayed.</li> <li>One of the following mode is displayed.<br/>                     Mode2: Open loop due to detected system malfunction<br/>                     Mode3: Open loop due to driving conditions (power enrichment, deceleration enrichment)<br/>                     Mode4: Closed loop - using oxygen sensor(s) as feedback for fuel control<br/>                     Mode5: Open loop - has not yet satisfied condition to go to closed loop</li> </ul> |
| FUEL SYS-B2                  |   |
| INT MANI PRES [kPa]          | <ul style="list-style-type: none"> <li>These items are displayed but are not applicable to this model.</li> </ul>   |
| COMBUST CONDITION            |   |

\*: The items are the same as those of 1st trip freeze frame data.

## DATA MONITOR MODE

### Monitored Item

| Monitored item | Unit     | Description   | Remarks   |
|----------------|----------|---|---|
| ENG SPEED      | rpm      | <ul style="list-style-type: none"> <li>Indicates the engine speed computed from the signal of the crankshaft position sensor (POS) and camshaft position sensor (PHASE).</li> </ul> | <ul style="list-style-type: none"> <li>Accuracy becomes poor if engine speed drops below the idle rpm.</li> <li>If the signal is interrupted while the engine is running, an abnormal value may be indicated.</li> </ul>  |
| MAS A/F SE-B1  | V        | <ul style="list-style-type: none"> <li>The signal voltage of the mass air flow sensor is displayed.</li> </ul>  | <ul style="list-style-type: none"> <li>When the engine is stopped, a certain value is indicated.</li> <li>When engine is running, specification range is indicated in "SPEC".</li> </ul>  |
| MAS A/F SE-B2  |          |   |   |
| B/FUEL SCHDL   | msec     | <ul style="list-style-type: none"> <li>"Base fuel schedule" indicates the fuel injection pulse width programmed into ECM, prior to any learned on board correction.</li> </ul>      | <ul style="list-style-type: none"> <li>When engine is running, specification range is indicated in "SPEC".</li> </ul>   |
| A/F ALPHA-B1   | %        | <ul style="list-style-type: none"> <li>The mean value of the air-fuel ratio feedback correction factor per cycle is indicated.</li> </ul>   | <ul style="list-style-type: none"> <li>When the engine is stopped, a certain value is indicated.</li> <li>This data also includes the data for the air-fuel ratio learning control.</li> <li>When engine is running, specification range is indicated in "SPEC".</li> </ul> |
| A/F ALPHA-B2   |          |   |   |
| COOLAN TEMP/S  | °C or °F | <ul style="list-style-type: none"> <li>The engine coolant temperature (determined by the signal voltage of the engine coolant temperature sensor) is displayed.</li> </ul>          | <ul style="list-style-type: none"> <li>When the engine coolant temperature sensor is open or short-circuited, ECM enters fail-safe mode. The engine coolant temperature determined by the ECM is displayed.</li> </ul>  |
| A/F SEN1 (B1)  | V        | <ul style="list-style-type: none"> <li>The A/F signal computed from the input signal of the air fuel ratio (A/F) sensor 1 is displayed.</li> </ul>                                  |   |
| A/F SEN1 (B2)  |          |   |   |
| HO2S2 (B1)     | V        | <ul style="list-style-type: none"> <li>The signal voltage of the heated oxygen sensor 2 is displayed.</li> </ul>  |   |
| HO2S2 (B2)     |          |   |   |

# DIAGNOSIS SYSTEM (ECM)

[VQ37VHR FOR USA AND CANADA]

## < SYSTEM DESCRIPTION >

| Monitored item  | Unit        | Description   | Remarks   |
|-----------------|-------------|---|---|
| HO2S2 MNTR (B1) | RICH/LEAN   | <ul style="list-style-type: none"> <li>Display of heated oxygen sensor 2 signal:<br/>RICH: means the amount of oxygen after three way catalyst is relatively small.<br/>LEAN: means the amount of oxygen after three way catalyst is relatively large.</li> </ul>           | <ul style="list-style-type: none"> <li>When the engine is stopped, a certain value is indicated.</li> </ul>   |
| HO2S2 MNTR (B2) |             |   |   |
| VHCL SPEED SE   | km/h or mph | <ul style="list-style-type: none"> <li>The vehicle speed computed from the vehicle speed signal sent from combination meter is displayed.</li> </ul>  |   |
| BATTERY VOLT    | V           | <ul style="list-style-type: none"> <li>The power supply voltage of ECM is displayed.</li> </ul>   |   |
| ACCEL SEN 1     | V           | <ul style="list-style-type: none"> <li>The accelerator pedal position sensor signal voltage is displayed.</li> </ul>  | <ul style="list-style-type: none"> <li>ACCEL SEN 2 signal is converted by ECM internally. Thus, they differs from ECM terminal voltage signal.</li> </ul> |
| ACCEL SEN 2     |             |   |   |
| TP SEN 1-B1     | V           | <ul style="list-style-type: none"> <li>The throttle position sensor signal voltage is displayed.</li> </ul>   | <ul style="list-style-type: none"> <li>TP SEN 2-B1 signal is converted by ECM internally. Thus, they differs from ECM terminal voltage signal.</li> </ul> |
| TP SEN 2-B1     |             |   |   |
| FUEL T/TMP SE   | °C or °F    | <ul style="list-style-type: none"> <li>The fuel temperature (determined by the signal voltage of the fuel tank temperature sensor) is displayed.</li> </ul>   |   |
| INT/A TEMP SE   | °C or °F    | <ul style="list-style-type: none"> <li>The intake air temperature (determined by the signal voltage of the intake air temperature sensor) is indicated.</li> </ul>  |   |
| EVAP SYS PRES   | V           | <ul style="list-style-type: none"> <li>The signal voltage of EVAP control system pressure sensor is displayed.</li> </ul>   |   |
| FUEL LEVEL SE   | V           | <ul style="list-style-type: none"> <li>The signal voltage of the fuel level sensor is displayed.</li> </ul>   |   |
| START SIGNAL    | ON/OFF      | <ul style="list-style-type: none"> <li>Indicates start signal status [ON/OFF] computed by the ECM according to the signals of engine speed and battery voltage.</li> </ul>  | <ul style="list-style-type: none"> <li>After starting the engine, [OFF] is displayed regardless of the starter signal.</li> </ul>                         |
| CLSD THL POS    | ON/OFF      | <ul style="list-style-type: none"> <li>Indicates idle position [ON/OFF] computed by ECM according to the accelerator pedal position sensor signal.</li> </ul>   |   |
| AIR COND SIG    | ON/OFF      | <ul style="list-style-type: none"> <li>Indicates [ON/OFF] condition of the air conditioner switch as determined by the air conditioner signal.</li> </ul>   |   |
| P/N POSI SW     | ON/OFF      | <ul style="list-style-type: none"> <li>Indicates [ON/OFF] condition from the park/neutral position (PNP) signal.</li> </ul>   |   |
| PW/ST SIGNAL    | ON/OFF      | <ul style="list-style-type: none"> <li>[ON/OFF] condition of the power steering system (determined by the signal voltage of the power steering pressure sensor signal) is indicated.</li> </ul>   |   |
| LOAD SIGNAL     | ON/OFF      | <ul style="list-style-type: none"> <li>Indicates [ON/OFF] condition from the electrical load signal.<br/>ON: Rear window defogger switch is ON and/or lighting switch is in 2nd position.<br/>OFF: Both rear window defogger switch and lighting switch are OFF.</li> </ul> |   |
| IGNITION SW     | ON/OFF      | <ul style="list-style-type: none"> <li>Indicates [ON/OFF] condition from ignition switch signal.</li> </ul>   |   |
| HEATER FAN SW   | ON/OFF      | <ul style="list-style-type: none"> <li>Indicates [ON/OFF] condition from the heater fan switch signal.</li> </ul>   |   |
| BRAKE SW        | ON/OFF      | <ul style="list-style-type: none"> <li>Indicates [ON/OFF] condition from the stop lamp switch signal.</li> </ul>  |   |
| INJ PULSE-B1    | msec        | <ul style="list-style-type: none"> <li>Indicates the actual fuel injection pulse width compensated by ECM according to the input signals.</li> </ul>  | <ul style="list-style-type: none"> <li>When the engine is stopped, a certain computed value is indicated.</li> </ul>                                      |
| INJ PULSE-B2    |             |   |   |
| IGN TIMING      | BTDC        | <ul style="list-style-type: none"> <li>Indicates the ignition timing computed by ECM according to the input signals.</li> </ul>   | <ul style="list-style-type: none"> <li>When the engine is stopped, a certain value is indicated.</li> </ul>   |

# DIAGNOSIS SYSTEM (ECM)

[VQ37VHR FOR USA AND CANADA]

## < SYSTEM DESCRIPTION >

| Monitored item  | Unit        | Description   | Remarks   |
|-----------------|-------------|---|---|
| CAL/LD VALUE    | %           | <ul style="list-style-type: none"> <li>“Calculated load value” indicates the value of the current air flow divided by peak air flow.</li> </ul>   |   |
| MASS AIRFLOW    | g/s         | <ul style="list-style-type: none"> <li>Indicates the mass air flow computed by ECM according to the signal voltage of the mass air flow sensor.</li> </ul>  |   |
| PURG VOL C/V    | %           | <ul style="list-style-type: none"> <li>Indicates the EVAP canister purge volume control solenoid valve control value computed by the ECM according to the input signals.</li> <li>The opening becomes larger as the value increases.</li> </ul>           |   |
| INT/V TIM (B1)  | °CA         | <ul style="list-style-type: none"> <li>Indicates [°CA] of intake camshaft advance angle.</li> </ul>   |   |
| INT/V TIM (B2)  |             |   |   |
| INT/V SOL (B1)  | %           | <ul style="list-style-type: none"> <li>The control value of the intake valve timing control solenoid valve (determined by ECM according to the input signals) is indicated.</li> <li>The advance angle becomes larger as the value increases.</li> </ul>  |   |
| INT/V SOL (B2)  |             |   |   |
| TP SEN 1-B2     | V           | <ul style="list-style-type: none"> <li>The throttle position sensor signal voltage is displayed.</li> </ul>   | <ul style="list-style-type: none"> <li>TP SEN 2-B2 signal is converted by ECM internally. Thus, they differs from ECM terminal voltage signal.</li> </ul> |
| TP SEN 2-B2     |             |   |   |
| AIR COND RLY    | ON/OFF      | <ul style="list-style-type: none"> <li>The air conditioner relay control condition (determined by ECM according to the input signals) is indicated.</li> </ul>  |   |
| FUEL PUMP RLY   | ON/OFF      | <ul style="list-style-type: none"> <li>Indicates the fuel pump relay control condition determined by ECM according to the input signals.</li> </ul>   |   |
| VENT CONT/V     | ON/OFF      | <ul style="list-style-type: none"> <li>The control condition of the EVAP canister vent control valve (determined by ECM according to the input signals) is indicated.</li> <li>ON: Closed</li> <li>OFF: Open</li> </ul>                                   |   |
| THRTL RELAY     | ON/OFF      | <ul style="list-style-type: none"> <li>Indicates the throttle control motor relay control condition determined by the ECM according to the input signals.</li> </ul>  |   |
| HO2S2 HTR (B1)  | ON/OFF      | <ul style="list-style-type: none"> <li>Indicates [ON/OFF] condition of heated oxygen sensor 2 heater determined by ECM according to the input signals.</li> </ul>   |   |
| HO2S2 HTR (B2)  |             |   |   |
| I/P PULLY SPD   | rpm         | <ul style="list-style-type: none"> <li>Indicates the engine speed computed from the input speed sensor signal.</li> </ul>   |   |
| VEHICLE SPEED   | km/h or mph | <ul style="list-style-type: none"> <li>The vehicle speed computed from the vehicle speed signal sent from TCM is displayed.</li> </ul>  |   |
| IDL A/V LEARN   | YET/CMPLT   | <ul style="list-style-type: none"> <li>Displays the condition of Idle Air Volume Learning</li> <li>YET: Idle air volume learning has not been performed yet.</li> <li>CMPLT: Idle air volume learning has already been performed successfully.</li> </ul> |   |
| SNOW MODE SW    | ON/OFF      | <ul style="list-style-type: none"> <li>Indicates [ON/OFF] condition from snow mode switch signal.</li> </ul>  |   |
| ENG OIL TEMP    | °C or °F    | <ul style="list-style-type: none"> <li>The engine oil temperature (determined by the signal voltage of the engine oil temperature sensor) is displayed.</li> </ul>  |   |
| TRVL AFTER MIL  | km or mile  | <ul style="list-style-type: none"> <li>Distance traveled while MIL is activated.</li> </ul>   |   |
| A/F S1 HTR (B1) | %           | <ul style="list-style-type: none"> <li>Air fuel ratio (A/F) sensor 1 heater control value computed by ECM according to the input signals.</li> <li>The current flow to the heater becomes larger as the value increases.</li> </ul>                       |   |
| A/F S1 HTR (B2) |             |   |   |

# DIAGNOSIS SYSTEM (ECM)

[VQ37VHR FOR USA AND CANADA]

< SYSTEM DESCRIPTION >

| Monitored item       | Unit        | Description  | Remarks |
|----------------------|-------------|--|---------|
| AC PRESS SEN         | V           | <ul style="list-style-type: none"> <li>The signal voltage from the refrigerant pressure sensor is displayed.</li> </ul>  | A       |
| VHCL SPEED SE        | km/h or mph | <ul style="list-style-type: none"> <li>The vehicle speed computed from the vehicle speed signal sent from combination meter is displayed.</li> </ul>   | EC      |
| SET VHCL SPD         | km/h or mph | <ul style="list-style-type: none"> <li>The preset vehicle speed is displayed.</li> </ul>   |         |
| MAIN SW              | ON/OFF      | <ul style="list-style-type: none"> <li>Indicates [ON/OFF] condition from MAIN switch signal.</li> </ul>  | C       |
| CANCEL SW            | ON/OFF      | <ul style="list-style-type: none"> <li>Indicates [ON/OFF] condition from CANCEL switch signal.</li> </ul>  | D       |
| RESUME/ACC SW        | ON/OFF      | <ul style="list-style-type: none"> <li>Indicates [ON/OFF] condition from RESUME/ACCELERATE switch signal.</li> </ul>   |         |
| SET SW               | ON/OFF      | <ul style="list-style-type: none"> <li>Indicates [ON/OFF] condition from SET/COAST switch signal.</li> </ul>   | E       |
| BRAKE SW1            | ON/OFF      | <ul style="list-style-type: none"> <li>Indicates [ON/OFF] condition from ASCD brake switch signal.</li> </ul>  | F       |
| BRAKE SW2            | ON/OFF      | <ul style="list-style-type: none"> <li>Indicates [ON/OFF] condition of stop lamp switch signal.</li> </ul>   |         |
| DIST SW              | ON/OFF      | <ul style="list-style-type: none"> <li>Indicates [ON/OFF] condition from DISTANCE switch signal.</li> </ul>  | G       |
| CRUISE LAMP          | ON/OFF      | <ul style="list-style-type: none"> <li>Indicates [ON/OFF] condition of CRUISE lamp determined by the ECM according to the input signals.</li> </ul>  | H       |
| BAT CUR SEN          | mV          | <ul style="list-style-type: none"> <li>The signal voltage of battery current sensor is displayed.</li> </ul>   | I       |
| MAP SENSOR           | V           | <ul style="list-style-type: none"> <li>The signal voltage from the manifold absolute pressure (MAP) sensor is displayed.</li> </ul>  |         |
| ALT DUTY             | %           | <ul style="list-style-type: none"> <li>Indicates the duty ratio of the power generation command value. The ratio is calculated by ECM based on the battery current sensor signal.</li> </ul>   | J       |
| BRAKE BST PRES SE    | mV          | <ul style="list-style-type: none"> <li>Always a certain value is displayed.</li> <li>This item is not efficient for Y51 models.</li> </ul>   | K       |
| VVEL POSITION SEN-B1 | V           | <ul style="list-style-type: none"> <li>The VVEL control shaft position sensor signal voltage is displayed.</li> </ul>  | L       |
| VVEL POSITION SEN-B2 |             |  |         |
| VVEL TIM-B1          | deg         | <ul style="list-style-type: none"> <li>Indicates [deg] of VVEL control shaft angle.</li> </ul>   | M       |
| VVEL TIM-B2          |             |  |         |
| VVEL LEARN           | YET/DONE    | <ul style="list-style-type: none"> <li>Display the condition of VVEL learning<br/>YET: VVEL learning has not been performed yet.<br/>DONE: VVEL learning has already been performed successfully.</li> </ul>   | N       |
| VVEL SEN LEARN-B1    | V           | <ul style="list-style-type: none"> <li>Indicates the VVEL learning value.</li> </ul>   | O       |
| VVEL SEN LEARN-B2    |             |  |         |
| A/F ADJ-B1           | —           | <ul style="list-style-type: none"> <li>Indicates the correction of factor stored in ECM. The factor is calculated from the difference between the target air-fuel ratio stored in ECM and the air-fuel ratio calculated from A/F sensor 1 signal.</li> </ul> |         |
| A/F ADJ-B2           |             |  |         |

# DIAGNOSIS SYSTEM (ECM)

< SYSTEM DESCRIPTION >

[VQ37VHR FOR USA AND CANADA]

| Monitored item      | Unit        | Description  | Remarks |
|---------------------|-------------|--|---------|
| FAN DUTY            | %           | <ul style="list-style-type: none"> <li>Indicates a command value for cooling fan. The value is calculated by ECM based on input signals.</li> </ul>  |         |
| ALT DUTY SIG        | ON/OFF      | <ul style="list-style-type: none"> <li>The control condition of the power generation voltage variable control (determined by ECM according to the input signals) is indicated.<br/>ON: Power generation voltage variable control is active.<br/>OFF: Power generation voltage variable control is inactive.</li> </ul> |         |
| BAT TEMP SEN        | V           | <ul style="list-style-type: none"> <li>The signal voltage from the battery temperature sensor is displayed.</li> </ul>   |         |
| EVAP LEAK DIAG      | YET/CMPLT   | <ul style="list-style-type: none"> <li>Indicates the condition of EVAP leak diagnosis.<br/>YET: EVAP leak diagnosis has not been performed yet.<br/>CMPLT: EVAP leak diagnosis has been performed successfully.</li> </ul>   |         |
| EVAP DIAG READY     | ON/OFF      | <ul style="list-style-type: none"> <li>Indicates the ready condition of EVAP leak diagnosis.<br/>ON: Diagnosis has been ready condition.<br/>OFF: Diagnosis has not been ready condition.</li> </ul>   |         |
| HO2 S2 DIAG1 (B1)   | INCMP/CMPLT | <ul style="list-style-type: none"> <li>Indicates DTC P0139 self-diagnosis (delayed response) condition.<br/>INCMP: Self-diagnosis is incomplete.<br/>CMPLT: Self-diagnosis is complete.</li> </ul>   |         |
| HO2 S2 DIAG1 (B2)   | INCMP/CMPLT | <ul style="list-style-type: none"> <li>Indicates DTC P0159 self-diagnosis (delayed response) condition.<br/>INCMP: Self-diagnosis is incomplete.<br/>CMPLT: Self-diagnosis is complete.</li> </ul>   |         |
| HO2 S2 DIAG2 (B1)   | INCMP/CMPLT | <ul style="list-style-type: none"> <li>Indicates DTC P0139 self-diagnosis (slow response) condition.<br/>INCMP: Self-diagnosis is incomplete.<br/>CMPLT: Self-diagnosis is complete.</li> </ul>  |         |
| HO2 S2 DIAG2 (B2)   | INCMP/CMPLT | <ul style="list-style-type: none"> <li>Indicates DTC P0159 self-diagnosis (slow response) condition.<br/>INCMP: Self-diagnosis is incomplete.<br/>CMPLT: Self-diagnosis is complete.</li> </ul>  |         |
| A/F SEN1 DIAG2 (B1) | —           | <b>NOTE:</b><br>The item is indicated, but not used.   |         |
| A/F SEN1 DIAG2 (B2) |             |  |         |
| THRTL STK CNT B1    | —           | <b>NOTE:</b><br>The item is indicated, but not used.   |         |
| THRTL STK CNT B2    |             |  |         |

**NOTE:**

Any monitored item that does not match the vehicle being diagnosed is deleted from the display automatically.

**ACTIVE TEST MODE**

Test Item

# DIAGNOSIS SYSTEM (ECM)

[VQ37VHR FOR USA AND CANADA]

< SYSTEM DESCRIPTION >

| TEST ITEM            | CONDITION   | JUDGEMENT  | CHECK ITEM (REMEDY)   |    |
|----------------------|---|--|---|----|
| VENT CONTROL/V       | <ul style="list-style-type: none"> <li>Ignition switch: ON (Engine stopped)</li> <li>Turn solenoid valve ON and OFF with the CONSULT and listen to operating sound.</li> </ul>  | Solenoid valve makes an operating sound.               | <ul style="list-style-type: none"> <li>Harness and connectors</li> <li>Solenoid valve</li> </ul>  | EC |
| ENG COOLANT TEMP     | <ul style="list-style-type: none"> <li>Engine: Return to the original trouble condition</li> <li>Change the engine coolant temperature using CONSULT.</li> </ul>  | If trouble symptom disappears, see CHECK ITEM.         | <ul style="list-style-type: none"> <li>Harness and connectors</li> <li>Engine coolant temperature sensor</li> <li>Fuel injector</li> </ul>  | C  |
| FUEL INJECTION       | <ul style="list-style-type: none"> <li>Engine: Return to the original trouble condition</li> <li>Change the amount of fuel injection using CONSULT.</li> </ul>  | If trouble symptom disappears, see CHECK ITEM.         | <ul style="list-style-type: none"> <li>Harness and connectors</li> <li>Fuel injector</li> <li>Air fuel ratio (A/F) sensor 1</li> </ul>  | D  |
| FUEL/T TEMP SEN      | <ul style="list-style-type: none"> <li>Change the fuel tank temperature using CONSULT.</li> </ul>   |  |   | E  |
| PURG VOL CONT/V      | <ul style="list-style-type: none"> <li>Engine: After warming up, run engine at 1,500 rpm.</li> <li>Change the EVAP canister purge volume control solenoid valve opening percent using CONSULT.</li> </ul>               | Engine speed changes according to the opening percent. | <ul style="list-style-type: none"> <li>Harness and connectors</li> <li>Solenoid valve</li> </ul>  | F  |
| FUEL PUMP RELAY      | <ul style="list-style-type: none"> <li>Ignition switch: ON (Engine stopped)</li> <li>Turn the fuel pump relay ON and OFF using CONSULT and listen to operating sound.</li> </ul>  | Fuel pump relay makes the operating sound.             | <ul style="list-style-type: none"> <li>Harness and connectors</li> <li>Fuel pump relay</li> </ul>   | G  |
| IGNITION TIMING      | <ul style="list-style-type: none"> <li>Engine: Return to the original trouble condition</li> <li>Timing light: Set</li> <li>Retard the ignition timing using CONSULT.</li> </ul>  | If trouble symptom disappears, see CHECK ITEM.         | <ul style="list-style-type: none"> <li>Perform Idle Air Volume Learning.</li> </ul>   | H  |
| FAN DUTY CONTROL*    | <ul style="list-style-type: none"> <li>Ignition switch: ON</li> <li>Change duty ratio using CONSULT.</li> </ul>   | Cooling fan speed changes.                             | <ul style="list-style-type: none"> <li>Harness and connectors</li> <li>Cooling fan motor</li> <li>Cooling fan relay</li> <li>Cooling fan control module</li> <li>IPDM E/R</li> </ul>      | J  |
| ALTERNATOR DUTY      | <ul style="list-style-type: none"> <li>Engine: Idle</li> <li>Change duty ratio using CONSULT.</li> </ul>  | Battery voltage changes.                               | <ul style="list-style-type: none"> <li>Harness and connectors</li> <li>IPDM E/R</li> <li>Alternator</li> </ul>  | K  |
| POWER BALANCE        | <ul style="list-style-type: none"> <li>Engine: After warming up, idle the engine.</li> <li>A/C switch OFF</li> <li>Selector lever: P or N</li> <li>Cut off each injector signal one at a time using CONSULT.</li> </ul> | Engine runs rough or dies.                             | <ul style="list-style-type: none"> <li>Harness and connectors</li> <li>Compression</li> <li>Fuel injector</li> <li>Power transistor</li> <li>Spark plug</li> <li>Ignition coil</li> </ul> | L  |
| INT V/T ASSIGN ANGLE | <ul style="list-style-type: none"> <li>Engine: Return to the original non-standard condition</li> <li>Change intake valve timing using CONSULT.</li> </ul>  | If malfunctioning symptom disappears, see CHECK ITEM.  | <ul style="list-style-type: none"> <li>Harness and connectors</li> <li>Intake valve timing control solenoid valve</li> </ul>  | M  |

\*: Leaving cooling fan OFF with CONSULT while engine is running may cause the engine to overheat.

## DTC & SRT CONFIRMATION MODE

### SRT STATUS Mode

- For items whose SRT codes are set, "CMPLT" is displayed on the CONSULT screen; for items whose SRT codes are not set, "INCMP" is displayed.
- "SRT STATUS" provides the presence or absence of permanent DTCs stored in ECM memory.

### PERMANENT DTC STATUS Mode

#### How to Display Permanent DTC Status

- Turn ignition switch OFF and wait at 10 seconds.
- Turn ignition switch ON.
- Turn ignition switch OFF and wait at 10 seconds.

# DIAGNOSIS SYSTEM (ECM)

[VQ37VHR FOR USA AND CANADA]

## < SYSTEM DESCRIPTION >

4. Turn ignition switch ON.
5. Select "PERMANENT DTC STATUS" in "DTC & SRT CONFIRMATION" mode with CONSULT.

**NOTE:**

Permanent DTCs stored in ECM memory are displayed on the CONSULT screen to show if a driving pattern required for erasing permanent DTCs is complete (CMPLT) or incomplete (INCMP).

**CAUTION:**

Since the "PERMANENT DTC STATUS" screen displays the previous trip information, repeat the following twice to update the information: "Ignition switch OFF", "Wait for more than 10 seconds" and "Ignition switch ON".

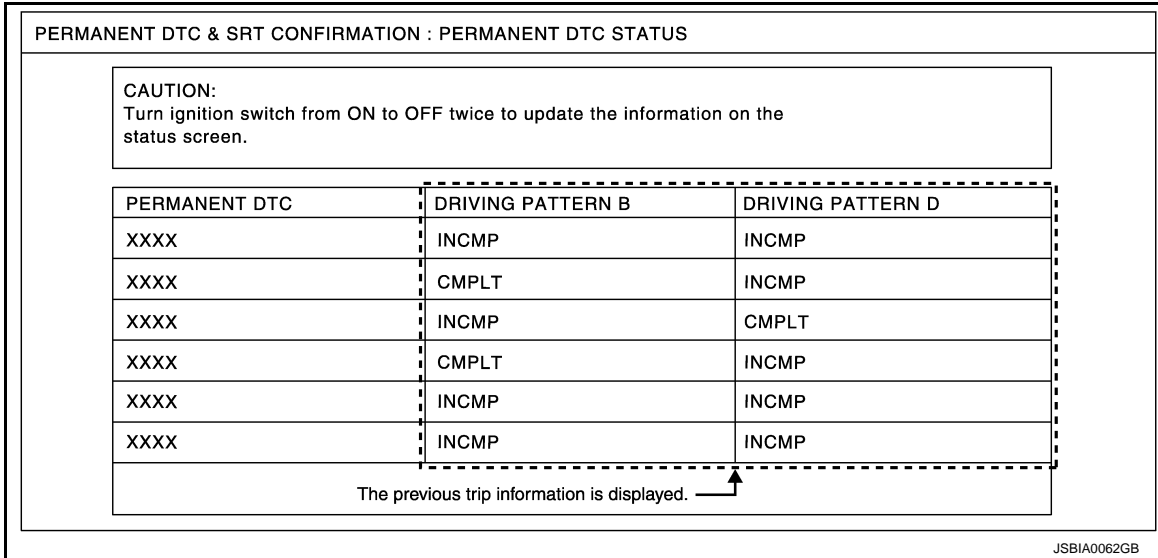

**NOTE:**

This mode is not used in regions that permanent DTCs are not regulated by law.

**SRT WORK SUPPORT Mode**

This mode enables a technician to drive a vehicle to set the SRT while monitoring the SRT status.

**PERMANENT DTC WORK SUPPORT Mode**

This mode enables a technician to drive a vehicle to complete the driving pattern that is required for erasing permanent DTC.

**NOTE:**

This mode is not used in regions that permanent DTCs are not regulated by law.

**DTC WORK SUPPORT Mode**

| Test mode          | Test item                  | Corresponding DTC No. | Reference page         |
|--------------------|----------------------------|-----------------------|------------------------|
| EVAPORATIVE SYSTEM | EVP SML LEAK P0442*/P1442* | —                     | —                      |
|                    | EVP V/S LEAK P0456/P1456*  | P0456                 | <a href="#">EC-360</a> |
|                    | PURG VOL CN/V P1444        | P0443                 | <a href="#">EC-331</a> |
|                    | PURG FLOW P0441            | P0441                 | <a href="#">EC-326</a> |
| A/F SEN1           | A/F SEN1 (B1) P1278/P1279  | P0133                 | <a href="#">EC-253</a> |
|                    | A/F SEN1 (B1) P1276        | P0130                 | <a href="#">EC-243</a> |
|                    | A/F SEN1 (B2) P1288/P1289  | P0153                 | <a href="#">EC-253</a> |
|                    | A/F SEN1 (B2) P1286        | P0150                 | <a href="#">EC-243</a> |
| HO2S2              | HO2S2 (B1) P1146           | P0138                 | <a href="#">EC-264</a> |
|                    | HO2S2 (B1) P1147           | P0137                 | <a href="#">EC-258</a> |
|                    | HO2S2 (B1) P0139           | P0139                 | <a href="#">EC-272</a> |
|                    | HO2S2 (B2) P1166           | P0158                 | <a href="#">EC-264</a> |
|                    | HO2S2 (B2) P1167           | P0157                 | <a href="#">EC-258</a> |
|                    | HO2S2 (B2) P0159           | P0159                 | <a href="#">EC-272</a> |



# DIAGNOSIS SYSTEM (ECM)

[VQ37VHR FOR USA AND CANADA]

< SYSTEM DESCRIPTION >

\*: DTC P0442, P1442 and P1456 does not apply to Y51 models but appears in DTC Work Support Mode screens.

A

EC

C

D

E

F

G

H

I

J

K

L

M

N

O

P

# ECU DIAGNOSIS INFORMATION

## ECM

### Reference Value

INFOID:000000006882816

### VALUES ON THE DIAGNOSIS TOOL

#### NOTE:

- Specification data are reference values.
- Specification data are output/input values which are detected or supplied by the ECM at the connector.
  - \* Specification data may not be directly related to their components signals/values/operations.
    - i.e. Adjust ignition timing with a timing light before monitoring IGN TIMING, because the monitor may show the specification data in spite of the ignition timing not being adjusted to the specification data. This IGN TIMING monitors the data calculated by the ECM according to the signals input from the camshaft position sensor and other ignition timing related sensors.

#### CONSULT MONITOR ITEM

| Monitor Item    | Condition  |                                       | Values/Status                                      |
|-----------------|--|---------------------------------------|--|
| ENG SPEED       | • Run engine and compare CONSULT value with the tachometer indication.   |                                       | Almost the same speed as the tachometer indication |
| MAS A/F SE-B1   | See <a href="#">EC-172, "Description"</a> .  |                                       |  |
| MAS A/F SE-B2   | See <a href="#">EC-172, "Description"</a> .  |                                       |  |
| B/FUEL SCHDL    | See <a href="#">EC-172, "Description"</a> .  |                                       |  |
| A/F ALPHA-B1    | See <a href="#">EC-172, "Description"</a> .  |                                       |  |
| A/F ALPHA-B2    | See <a href="#">EC-172, "Description"</a> .  |                                       |  |
| COOLAN TEMP/S   | • Ignition switch: ON  |                                       | Indicates engine coolant temperature               |
| A/F SEN1 (B1)   | • Engine: After warming up   | Maintaining engine speed at 2,000 rpm | Fluctuates around 2.2 V                            |
| A/F SEN1 (B2)   | • Engine: After warming up   | Maintaining engine speed at 2,000 rpm | Fluctuates around 2.2 V                            |
| HO2S2 (B1)      | <ul style="list-style-type: none"> <li>• Revving engine from idle up to 3,000 rpm quickly after the following conditions are met.</li> <li>- Engine: After warming up</li> <li>- After keeping engine speed between 3,500 and 4,000 rpm for 1 minute and at idle for 1 minute under no load</li> </ul> |                                       | 0 - 0.3 V ↔ Approx. 0.6 - 1.0 V                    |
| HO2S2 (B2)      | <ul style="list-style-type: none"> <li>• Revving engine from idle up to 3,000 rpm quickly after the following conditions are met.</li> <li>- Engine: After warming up</li> <li>- After keeping engine speed between 3,500 and 4,000 rpm for 1 minute and at idle for 1 minute under no load</li> </ul> |                                       | 0 - 0.3 V ↔ Approx. 0.6 - 1.0 V                    |
| HO2S2 MNTR (B1) | <ul style="list-style-type: none"> <li>• Revving engine from idle up to 3,000 rpm quickly after the following conditions are met.</li> <li>- Engine: After warming up</li> <li>- After keeping engine speed between 3,500 and 4,000 rpm for 1 minute and at idle for 1 minute under no load</li> </ul> |                                       | LEAN ↔ RICH  |
| HO2S2 MNTR (B2) | <ul style="list-style-type: none"> <li>• Revving engine from idle up to 3,000 rpm quickly after the following conditions are met.</li> <li>- Engine: After warming up</li> <li>- After keeping engine speed between 3,500 and 4,000 rpm for 1 minute and at idle for 1 minute under no load</li> </ul> |                                       | LEAN ↔ RICH  |
| VHCL SPEED SE   | • Turn drive wheels and compare CONSULT value with the speedometer indication.   |                                       | Almost the same speed as speedometer indication    |
| BATTERY VOLT    | • Ignition switch: ON (Engine stopped)   |                                       | 11 - 14 V  |
| ACCEL SEN 1     | • Ignition switch: ON (Engine stopped)   | Accelerator pedal: Fully released     | 0.45 - 1.00 V                                      |
|                 |  | Accelerator pedal: Fully depressed    | 4.4 - 4.8 V  |
| ACCEL SEN 2*1   | • Ignition switch: ON (Engine stopped)   | Accelerator pedal: Fully released     | 0.45 - 1.00 V                                      |
|                 |  | Accelerator pedal: Fully depressed    | 4.3 - 4.8 V  |

# ECM

## < ECU DIAGNOSIS INFORMATION >

**[VQ37VHR FOR USA AND CANADA]**

| Monitor Item  | Condition  |  | Values/Status                        |
|---------------|--|--|--------------------------------------|
| TP SEN 1-B1   | <ul style="list-style-type: none"> <li>Ignition switch: ON (Engine stopped)</li> <li>Selector lever: D</li> </ul>  | Accelerator pedal: Fully released                                    | More than 0.36 V                     |
|               |  | Accelerator pedal: Fully depressed                                   | Less than 4.75 V                     |
| TP SEN 2-B1*1 | <ul style="list-style-type: none"> <li>Ignition switch: ON (Engine stopped)</li> <li>Selector lever: D</li> </ul>  | Accelerator pedal: Fully released                                    | More than 0.36 V                     |
|               |  | Accelerator pedal: Fully depressed                                   | Less than 4.75 V                     |
| FUEL T/TMP SE | <ul style="list-style-type: none"> <li>Ignition switch: ON</li> </ul>  |  | Indicates fuel tank temperature      |
| INT/A TEMP SE | <ul style="list-style-type: none"> <li>Ignition switch: ON</li> </ul>  |  | Indicates intake air temperature     |
| EVAP SYS PRES | <ul style="list-style-type: none"> <li>Ignition switch: ON</li> </ul>  |  | Approx. 1.8 - 4.8 V                  |
| FUEL LEVEL SE | <ul style="list-style-type: none"> <li>Ignition switch: ON</li> </ul>  |  | Depending on fuel level of fuel tank |
| START SIGNAL  | <ul style="list-style-type: none"> <li>Ignition switch: ON → START → ON</li> </ul>   |  | OFF → ON → OFF                       |
| CLSD THL POS  | <ul style="list-style-type: none"> <li>Ignition switch: ON (Engine stopped)</li> </ul>   | Accelerator pedal: Fully released                                    | ON                                   |
|               |  | Accelerator pedal: Slightly depressed                                | OFF                                  |
| AIR COND SIG  | <ul style="list-style-type: none"> <li>Engine: After warming up, idle the engine</li> </ul>  | Air conditioner switch: OFF  | OFF                                  |
|               |  | Air conditioner switch: ON (Compressor operates.)                    | ON                                   |
| P/N POSI SW   | <ul style="list-style-type: none"> <li>Ignition switch: ON</li> </ul>  | Selector lever: P or N   | ON                                   |
|               |  | Selector lever: Except above   | OFF                                  |
| PW/ST SIGNAL  | <ul style="list-style-type: none"> <li>Engine: After warming up, idle the engine</li> </ul>  | Steering wheel: Not being turned                                     | OFF                                  |
|               |  | Steering wheel: Being turned   | ON                                   |
| LOAD SIGNAL   | <ul style="list-style-type: none"> <li>Ignition switch: ON</li> </ul>  | Rear window defogger switch: ON and/or Lighting switch: 2nd position | ON                                   |
|               |  | Rear window defogger switch and lighting switch: OFF                 | OFF                                  |
| IGNITION SW   | <ul style="list-style-type: none"> <li>Ignition switch: ON → OFF → ON</li> </ul>   |  | ON → OFF → ON                        |
| HEATER FAN SW | <ul style="list-style-type: none"> <li>Engine: After warming up, idle the engine</li> </ul>  | Heater fan switch: ON  | ON                                   |
|               |  | Heater fan switch: OFF   | OFF                                  |
| BRAKE SW      | <ul style="list-style-type: none"> <li>Ignition switch: ON</li> </ul>  | Brake pedal: Fully released  | OFF                                  |
|               |  | Brake pedal: Slightly depressed                                      | ON                                   |
| INJ PULSE-B1  | <ul style="list-style-type: none"> <li>Engine: After warming up</li> <li>Selector lever: P or N</li> <li>Air conditioner switch: OFF</li> <li>No load</li> </ul> | Idle   | 2.0 - 3.0 msec                       |
|               |  | 2,000 rpm  | 1.9 - 2.9 msec                       |
| INJ PULSE-B2  | <ul style="list-style-type: none"> <li>Engine: After warming up</li> <li>Selector lever: P or N</li> <li>Air conditioner switch: OFF</li> <li>No load</li> </ul> | Idle   | 2.0 - 3.0 msec                       |
|               |  | 2,000 rpm  | 1.9 - 2.9 msec                       |
| IGN TIMING    | <ul style="list-style-type: none"> <li>Engine: After warming up</li> <li>Selector lever: P or N</li> <li>Air conditioner switch: OFF</li> <li>No load</li> </ul> | Idle   | 7° BTDC                              |
|               |  | 2,000 rpm  | 25° - 45° BTDC                       |
| CAL/LD VALUE  | <ul style="list-style-type: none"> <li>Engine: After warming up</li> <li>Selector lever: P or N</li> <li>Air conditioner switch: OFF</li> <li>No load</li> </ul> | Idle   | 5% - 35%                             |
|               |  | 2,500 rpm  | 5% - 35%                             |
| MASS AIRFLOW  | <ul style="list-style-type: none"> <li>Engine: After warming up</li> <li>Selector lever: P or N</li> <li>Air conditioner switch: OFF</li> <li>No load</li> </ul> | Idle   | 2.0 - 6.0 g/s                        |
|               |  | 2,500 rpm  | 7.0 - 20.0 g/s                       |

A

EC

C

D

E

F

G

H

I

J

K

L

M

N

O

P

# ECM

< ECU DIAGNOSIS INFORMATION >

[VQ37VHR FOR USA AND CANADA]

| Monitor Item   | Condition   | Values/Status  |   |
|----------------|---|--|---|
| PURG VOL C/V   | <ul style="list-style-type: none"> <li>Engine: After warming up</li> <li>Selector lever: P or N</li> <li>Air conditioner switch: OFF</li> <li>No load</li> </ul>  | Idle<br>(Accelerator pedal: Not depressed even slightly, after engine starting.) | 0%  |
|                |   | 2,000 rpm  | —   |
| INT/V TIM (B1) | <ul style="list-style-type: none"> <li>Engine: After warming up</li> <li>Selector lever: P or N</li> <li>Air conditioner switch: OFF</li> <li>No load</li> </ul>  | Idle   | - 5 - 5°C   |
|                |   | 2,000 rpm  | Approx. 0 - 30°C                                    |
| INT/V TIM (B2) | <ul style="list-style-type: none"> <li>Engine: After warming up</li> <li>Selector lever: P or N</li> <li>Air conditioner switch: OFF</li> <li>No load</li> </ul>  | Idle   | - 5 - 5°C   |
|                |   | 2,000 rpm  | Approx. 0 - 30°C                                    |
| INT/V SOL (B1) | <ul style="list-style-type: none"> <li>Engine: After warming up</li> <li>Selector lever: P or N</li> <li>Air conditioner switch: OFF</li> <li>No load</li> </ul>  | Idle   | 0 - 2%  |
|                |   | 2,000 rpm  | Approx. 0 - 50%                                     |
| INT/V SOL (B2) | <ul style="list-style-type: none"> <li>Engine: After warming up</li> <li>Selector lever: P or N</li> <li>Air conditioner switch: OFF</li> <li>No load</li> </ul>  | Idle   | 0 - 2%  |
|                |   | 2,000 rpm  | Approx. 0 - 50%                                     |
| TP SEN 1-B2    | <ul style="list-style-type: none"> <li>Ignition switch: ON (Engine stopped)</li> <li>Selector lever: D</li> </ul>   | Accelerator pedal: Fully released  | More than 0.36 V                                    |
|                |   | Accelerator pedal: Fully depressed   | Less than 4.75 V                                    |
| TP SEN 2-B2*1  | <ul style="list-style-type: none"> <li>Ignition switch: ON (Engine stopped)</li> <li>Selector lever: D</li> </ul>   | Accelerator pedal: Fully released  | More than 0.36 V                                    |
|                |   | Accelerator pedal: Fully depressed   | Less than 4.75 V                                    |
| AIR COND RLY   | <ul style="list-style-type: none"> <li>Engine: After warming up, idle the engine</li> </ul>   | Air conditioner switch: OFF  | OFF   |
|                |   | Air conditioner switch: ON (Compressor operates)                                 | ON  |
| FUEL PUMP RLY  | <ul style="list-style-type: none"> <li>For 1 second after turning ignition switch: ON</li> <li>Engine running or cranking</li> </ul>  |  | ON  |
|                |   | <ul style="list-style-type: none"> <li>Except above</li> </ul>                   | OFF   |
| VENT CONT/V    | <ul style="list-style-type: none"> <li>Ignition switch: ON</li> </ul>   |  | OFF   |
| THRTL RELAY    | <ul style="list-style-type: none"> <li>Ignition switch: ON</li> </ul>   |  | ON  |
| HO2S2 HTR (B1) | <ul style="list-style-type: none"> <li>Engine speed: Below 3,600 rpm after the following conditions are met.                             <ul style="list-style-type: none"> <li>- Engine: After warming up</li> <li>- Keeping the engine speed between 3,500 and 4,000 rpm for 1 minute and at idle for 1 minute under no load</li> </ul> </li> </ul> |  | ON  |
|                |   | <ul style="list-style-type: none"> <li>Engine speed: Above 3,600 rpm</li> </ul>  | OFF   |
| HO2S2 HTR (B2) | <ul style="list-style-type: none"> <li>Engine speed: Below 3,600 rpm after the following conditions are met.                             <ul style="list-style-type: none"> <li>- Engine: After warming up</li> <li>- Keeping the engine speed between 3,500 and 4,000 rpm for 1 minute and at idle for 1 minute under no load</li> </ul> </li> </ul> |  | ON  |
|                |   | <ul style="list-style-type: none"> <li>Engine speed: Above 3,600 rpm</li> </ul>  | OFF   |
| I/P PULLY SPD  | <ul style="list-style-type: none"> <li>Vehicle speed: More than 20 km/h (12 MPH)</li> </ul>   |  | Almost the same speed as the tachometer indication  |
| VEHICLE SPEED  | <ul style="list-style-type: none"> <li>Turn drive wheels and compare CONSULT value with the speedometer indication.</li> </ul>  |  | Almost the same speed as the speedometer indication |
| IDL A/V LEARN  | <ul style="list-style-type: none"> <li>Engine: Running</li> </ul>   | Idle air volume learning has not been performed yet.                             | YET   |
|                |   | Idle air volume learning has already been performed successfully.                | CMPLT   |
| SNOW MODE SW   | <ul style="list-style-type: none"> <li>Ignition switch: ON</li> </ul>   | Snow mode switch: Pressed  | ON  |
|                |   | Snow mode switch: Released   | OFF   |

# ECM

< ECU DIAGNOSIS INFORMATION >

[VQ37VHR FOR USA AND CANADA]

| Monitor Item                         | Condition  |  | Values/Status                                       |
|--------------------------------------|--|--|---|
| ENG OIL TEMP                         | • Engine: After warming up   |  | More than 70°C (158°F)                              |
| TRVL AFTER MIL                       | • Ignition switch: ON  | Vehicle has traveled after MIL has illuminated.        | 0 - 65,535 km<br>(0 - 40,723 miles)                 |
| A/F S1 HTR (B1)                      | • Engine: After warming up, idle the engine<br>(More than 140 seconds after starting engine)                                 |  | 4 - 100%  |
| A/F S1 HTR (B2)                      | • Engine: After warming up, idle the engine<br>(More than 140 seconds after starting engine)                                 |  | 4 - 100%  |
| AC PRESS SEN                         | • Engine: Idle<br>• Both A/C switch and blower fan switch: ON (Compressor operates)  |  | 1.0 - 4.0 V   |
| VHCL SPEED SE                        | • Turn drive wheels and compare CONSULT value with the speedometer indication.   |  | Almost the same speed as the speedometer indication |
| SET VHCL SPD                         | • Engine: Running  | ASCD: Operating  | The preset vehicle speed is displayed               |
| MAIN SW                              | • Ignition switch: ON  | MAIN switch: Pressed                                   | ON  |
|                                      |  | MAIN switch: Released                                  | OFF   |
| CANCEL SW                            | • Ignition switch: ON  | CANCEL switch: Pressed                                 | ON  |
|                                      |  | CANCEL switch: Released                                | OFF   |
| RESUME/ACC SW                        | • Ignition switch: ON  | RESUME/ACCELERATE switch: Pressed                      | ON  |
|                                      |  | RESUME/ACCELERATE switch: Released                     | OFF   |
| SET SW                               | • Ignition switch: ON  | SET/COAST switch: Pressed                              | ON  |
|                                      |  | SET/COAST switch: Released                             | OFF   |
| BRAKE SW1<br>(ICC/ASCD brake switch) | • Ignition switch: ON  | Brake pedal: Fully released                            | ON  |
|                                      |  | Brake pedal: Slightly depressed                        | OFF   |
| BRAKE SW2<br>(Stop lamp switch)      | • Ignition switch: ON  | Brake pedal: Fully released                            | OFF   |
|                                      |  | Brake pedal: Slightly depressed                        | ON  |
| DIST SW                              | • Ignition switch: ON  | DISTANCE switch: Pressed                               | ON  |
|                                      |  | DISTANCE switch: Released                              | OFF   |
| CRUISE LAMP                          | • Ignition switch: ON  | MAIN switch: Pressed at the 1st time → at the 2nd time | ON → OFF  |
| BAT CUR SEN                          | • Engine speed: Idle<br>• Battery: Fully charged*2<br>• Selector lever: P or N<br>• Air conditioner switch: OFF<br>• No load |  | Approx. 2,600 - 3,500 mV                            |
| MAP SENSOR                           | • Engine: After warming up<br>• Selector lever: P or N<br>• A/C switch: OFF<br>• No load                                     | Idle   | Approx. 1.0 V                                       |
|                                      |  | 2,000 rpm  | Approx. 1.35 V                                      |
| ALT DUTY                             | • Engine: Idle   |  | 0 - 80%   |
| BRAKE BST PRES SE                    | • This item is displayed but is not applicable to this model.  |  |   |
| VVEL POSITION<br>SEN-B1              | • Engine: After warming up<br>• Selector lever: P or N<br>• Air conditioner switch: OFF<br>• No load                         | Idle   | Approx. 0.25 - 1.40 V                               |
|                                      |  | When revving engine up to 2,000 rpm quickly            | Approx. 0.25 - 4.75 V                               |
| VVEL POSITION<br>SEN-B2              | • Engine: After warming up<br>• Selector lever: P or N<br>• Air conditioner switch: OFF<br>• No load                         | Idle   | Approx. 0.25 - 1.40 V                               |
|                                      |  | When revving engine up to 2,000 rpm quickly            | Approx. 0.25 - 4.75 V                               |

A

EC

C

D

E

F

G

H

I

J

K

L

M

N

O

P

# ECM

## < ECU DIAGNOSIS INFORMATION >

[VQ37VHR FOR USA AND CANADA]

| Monitor Item        | Condition  |  | Values/Status                                       |
|---------------------|--|--|---|
| VVEL TIM-B1         | <ul style="list-style-type: none"> <li>Engine: After warming up</li> <li>Selector lever: P or N</li> <li>Air conditioner switch: OFF</li> <li>No load</li> </ul> | Idle   | Approx. 0 - 20 deg                                  |
|                     |  | When revving engine up to 2,000 rpm quickly            | Approx. 0 - 90 deg                                  |
| VVEL TIM-B2         | <ul style="list-style-type: none"> <li>Engine: After warming up</li> <li>Selector lever: P or N</li> <li>Air conditioner switch: OFF</li> <li>No load</li> </ul> | Idle   | Approx. 0 - 20 deg                                  |
|                     |  | When revving engine up to 2,000 rpm quickly            | Approx. 0 - 90 deg                                  |
| VVEL LEARN          | <ul style="list-style-type: none"> <li>Ignition switch: OFF → ON (After warming up)</li> </ul>   | VVEL learning has not been performed yet.              | YET   |
|                     |  | VVEL learning has already been performed successfully. | DONE  |
| VVEL SEN LEARN-B1   | <ul style="list-style-type: none"> <li>VVEL learning has already been performed successfully</li> </ul>  |  | Approx. 0.30 - 0.80 V                               |
| VVEL SEN LEARN-B2   | <ul style="list-style-type: none"> <li>VVEL learning has already been performed successfully</li> </ul>  |  | Approx. 0.30 - 0.80 V                               |
| A/F ADJ-B1          | <ul style="list-style-type: none"> <li>Engine: Running</li> </ul>  |  | -0.330 - 0.330                                      |
| A/F ADJ-B2          | <ul style="list-style-type: none"> <li>Engine: Running</li> </ul>  |  | -0.330 - 0.330                                      |
| FAN DUTY            | <ul style="list-style-type: none"> <li>Engine: Running</li> </ul>  |  | 0 - 100%  |
| ALT DUTY SIG        | <ul style="list-style-type: none"> <li>Power generation voltage variable control: Operating</li> </ul>   |  | ON  |
|                     | <ul style="list-style-type: none"> <li>Power generation voltage variable control: Not operating</li> </ul>   |  | OFF   |
| BAT TEMP SEN        | <ul style="list-style-type: none"> <li>Engine: After warming up</li> <li>Selector lever: P or N</li> <li>A/C switch: OFF</li> <li>No load</li> </ul>             | Idle   | Indicates the temperature around the battery.       |
| EVAP LEAK DIAG      | <ul style="list-style-type: none"> <li>Ignition switch: ON</li> </ul>  |  | Depending on condition of EVAP leak diagnosis       |
| EVAP DIAG READY     | <ul style="list-style-type: none"> <li>Ignition switch: ON (READY)</li> </ul>  |  | Depending on ready condition of EVAP leak diagnosis |
| HO2 S2 DIAG1 (B1)   | DTC P0139 self-diagnosis (delayed response) is incomplete.   |  | INCMP   |
|                     | DTC P0139 self-diagnosis (delayed response) is complete.   |  | CMPLT   |
| HO2 S2 DIAG1 (B2)   | DTC P0159 self-diagnosis (delayed response) is incomplete.   |  | INCMP   |
|                     | DTC P0159 self-diagnosis (delayed response) is complete.   |  | CMPLT   |
| HO2 S2 DIAG2 (B1)   | DTC P0139 self-diagnosis (slow response) is incomplete.  |  | INCMP   |
|                     | DTC P0139 self-diagnosis (slow response) is complete.  |  | CMPLT   |
| HO2 S2 DIAG2 (B2)   | DTC P0159 self-diagnosis (slow response) is incomplete.  |  | INCMP   |
|                     | DTC P0159 self-diagnosis (slow response) is complete.  |  | CMPLT   |
| A/F SEN1 DIAG2 (B1) | <ul style="list-style-type: none"> <li>This item is displayed but is not applicable to this model.</li> </ul>  |  |   |
| A/F SEN1 DIAG2 (B2) | <ul style="list-style-type: none"> <li>This item is displayed but is not applicable to this model.</li> </ul>  |  |   |
| THRTL STK CNT B1    | <ul style="list-style-type: none"> <li>This item is displayed but is not applicable to this model.</li> </ul>  |  |   |
| THRTL STK CNT B2    | <ul style="list-style-type: none"> <li>This item is displayed but is not applicable to this model.</li> </ul>  |  |   |

\*1: Accelerator pedal position sensor 2 signal and throttle position sensor 2 signal are converted by ECM internally. Thus, they differ from ECM terminals voltage signal.

\*2: Before measuring the terminal voltage, confirm that the battery is fully charged. Refer to [PG-135, "How to Handle Battery"](#).

TERMINAL LAYOUT

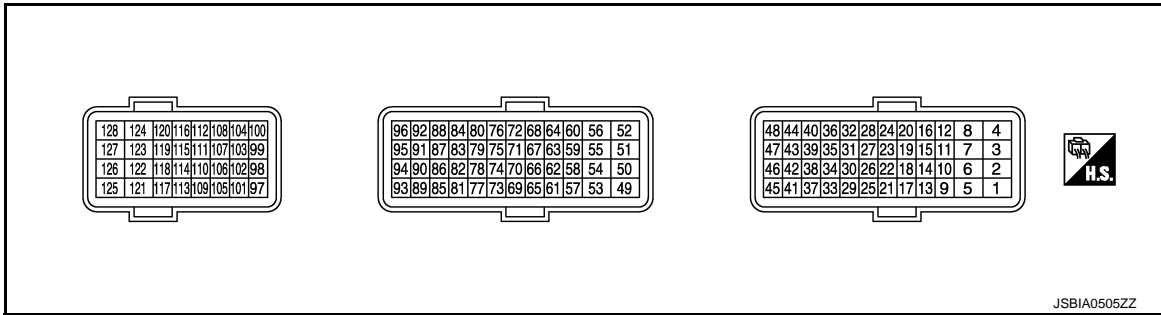

PHYSICAL VALUES

NOTE:

- ECM is located behind the instrument assist lower panel. For this inspection, remove passenger side instrument lower panel.
- Specification data are reference values and are measured between each terminal and ground.
- Pulse signal is measured by CONSULT.

| Terminal No.<br>(Wire color) |            | Description                                     |                  | Condition  | Value<br>(Approx.)              |
|------------------------------|------------|---|------------------|--|---------------------------------|
| +                            | --         | Signal name                                     | Input/<br>Output |  |                                 |
| 1<br>(W)                     | 128<br>(B) | A/F sensor 1 heater<br>(bank 1)                 | Output           | [Engine is running]<br>• Warm-up condition<br>• Idle speed<br>(More than 140 seconds after starting engine)                        | 2.9 - 8.8 V★<br><br>JMBIA0030GB |
| 2<br>(G)                     | 128<br>(B) | Throttle control motor<br>(Open) (bank 1)       | Output           | [Ignition switch: ON]<br>• Engine stopped<br>• Selector lever: D<br>• Accelerator pedal: Fully depressed                           | 0 - 14 V★<br><br>JMBIA0031GB    |
|                              |            |   |                  | [Ignition switch: ON]<br>• Engine stopped<br>• Selector lever: D<br>• Accelerator pedal: Fully released                            | 0 - 14 V★<br><br>JMBIA0032GB    |
| 3<br>(R)                     | 128<br>(B) | Throttle control motor<br>power supply (bank 1) | Input            | [Ignition switch: ON]  | BATTERY VOLTAGE<br>(11 - 14 V)  |
| 4<br>(BR)                    | 128<br>(B) | Throttle control motor<br>(Close) (bank 1)      | Output           | [Ignition switch: ON]<br>• Engine stopped<br>• Selector lever: D<br>• Accelerator pedal: In the middle of re-<br>leasing operation | 0 - 14 V★<br><br>JMBIA0033GB    |

# ECM

< ECU DIAGNOSIS INFORMATION >

[VQ37VHR FOR USA AND CANADA]

| Terminal No.<br>(Wire color) |                       | Description  |                  | Condition  | Value<br>(Approx.)             |
|------------------------------|-----------------------|--|------------------|--|--------------------------------|
| +                            | --                    | Signal name  | Input/<br>Output |  |                                |
| 5<br>(L)                     | 128<br>(B)            | A/F sensor 1 heater<br>(bank 2)  | Output           | [Engine is running] <ul style="list-style-type: none"> <li>• Warm-up condition</li> <li>• Idle speed<br/>(More than 140 seconds after starting engine)</li> </ul>  | 2.9 - 8.8 V★<br>               |
| 8<br>(B)                     | —                     | ECM ground   | —                | —  | —                              |
| 11<br>(GR)                   | 128<br>(B)            | Ignition signal No. 4  | Output           | [Engine is running] <ul style="list-style-type: none"> <li>• Warm-up condition</li> <li>• Idle speed</li> </ul> <b>NOTE:</b><br>The pulse cycle changes depending on rpm at idle   | 0 - 0.2 V★<br>                 |
| 12<br>(L)                    |                       | Ignition signal No. 3  |                  |  |                                |
| 15<br>(LG)                   |                       | Ignition signal No. 5  |                  |  |                                |
| 16<br>(G)                    |                       | Ignition signal No. 2  |                  |  |                                |
| 19<br>(V)                    |                       | Ignition signal No. 6  |                  |  |                                |
| 20<br>(Y)                    | Ignition signal No. 1 | [Engine is running] <ul style="list-style-type: none"> <li>• Warm-up condition</li> <li>• Engine speed: 2,000 rpm</li> </ul> | 0.1 - 0.4 V★<br> |  |                                |
| 17<br>(P)                    | 128<br>(B)            | Heated oxygen sensor 2 heater (bank 1)   | Output           | [Engine is running] <ul style="list-style-type: none"> <li>• Engine speed: Below 3,600 rpm after the following conditions are met                             <ul style="list-style-type: none"> <li>- Engine: after warming up</li> <li>- Keeping the engine speed between 3,500 and 4,000 rpm for 1 minute and at idle for 1 minute under no load</li> </ul> </li> </ul> | 10 V★<br>                      |
|                              |                       |  |                  | [Ignition switch: ON] <ul style="list-style-type: none"> <li>• Engine stopped</li> </ul> [Engine is running] <ul style="list-style-type: none"> <li>• Engine speed: Above 3,600 rpm</li> </ul>   | BATTERY VOLTAGE<br>(11 - 14 V) |
| 18<br>(Y)                    | 128<br>(B)            | Intake valve timing control solenoid valve (bank 1)  | Output           | [Engine is running] <ul style="list-style-type: none"> <li>• Warm-up condition</li> <li>• Idle speed</li> </ul>  | BATTERY VOLTAGE<br>(11 - 14 V) |
|                              |                       |  |                  | [Engine is running] <ul style="list-style-type: none"> <li>• Warm-up condition</li> <li>• Engine speed: 2,000rpm</li> </ul>  | 7 - 12 V★<br>                  |



# ECM

< ECU DIAGNOSIS INFORMATION >

[VQ37VHR FOR USA AND CANADA]

| Terminal No.<br>(Wire color) |            | Description  |                  | Condition  | Value<br>(Approx.)   |
|------------------------------|------------|--|------------------|--|--|
| +                            | --         | Signal name  | Input/<br>Output |  |  |
| 21<br>(GR)                   | 128<br>(B) | EVAP canister purge volume control solenoid valve            | Output           | [Engine is running]<br>• Idle speed<br>• Accelerator pedal: Not depressed even slightly, after engine starting | BATTERY VOLTAGE<br>(11 - 14 V)★<br>                          |
|                              |            |  |                  | [Engine is running]<br>• Engine speed: About 2,000 rpm (More than 100 seconds after starting engine)           | BATTERY VOLTAGE<br>(11 - 14 V)★<br>                          |
| 22<br>(B)                    | 128<br>(B) | Fuel pump relay  | Output           | [Ignition switch: ON]<br>• For 1 second after turning ignition switch ON                                       | 0 - 1.5 V  |
|                              |            |  |                  | [Engine is running]<br>• More than 1 second after turning ignition switch ON                                   | BATTERY VOLTAGE<br>(11 - 14 V)                               |
| 24<br>(V)                    | 128<br>(B) | ECM relay (Self shut-off)                                    | Output           | [Engine is running]<br>[Ignition switch: OFF]<br>• A few seconds after turning ignition switch OFF             | 0 - 1.5 V  |
|                              |            |  |                  | [Ignition switch: OFF]<br>• More than a few seconds after turning ignition switch OFF                          | BATTERY VOLTAGE<br>(11 - 14 V)                               |
| 25<br>(O)                    | 128<br>(B) | Throttle control motor relay                                 | Output           | [Ignition switch: ON → OFF]  | 0 - 1.0 V<br>↓<br>BATTERY VOLTAGE<br>(11 - 14 V)<br>↓<br>0 V |
|                              |            |  |                  | [Ignition switch: ON]  | 0 - 1.0 V  |
| 28<br>(R)                    | 128<br>(B) | VVEL actuator motor relay abort signal [VVEL control module] | Output           | [Engine is running]<br>• Warm-up condition<br>• Idle speed   | 0 V  |
| 29<br>(Y)                    | 128<br>(B) | Intake valve timing control solenoid valve (bank 2)          | Output           | [Engine is running]<br>• Warm-up condition<br>• Idle speed   | BATTERY VOLTAGE<br>(11 - 14 V)                               |
|                              |            |  |                  | [Engine is running]<br>• Warm-up condition<br>• Engine speed: 2,000rpm   | 7 - 12 V★<br>  |

A  
EC  
C  
D  
E  
F  
G  
H  
I  
J  
K  
L  
M  
N  
O  
P

# ECM

< ECU DIAGNOSIS INFORMATION >

[VQ37VHR FOR USA AND CANADA]

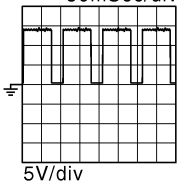
| Terminal No.<br>(Wire color) |             | Description                               |                  | Condition  | Value<br>(Approx.)  |
|------------------------------|-------------|---|------------------|--|---|
| +                            | -           | Signal name                               | Input/<br>Output |  |   |
| 30<br>(O)                    | 40<br>(O/L) | Throttle position sensor<br>1 (bank 1)    | Input            | [Ignition switch: ON]<br>• Engine stopped<br>• Selector lever: D<br>• Accelerator pedal: Fully released  | More than 0.36 V  |
|                              |             |   |                  | [Ignition switch: ON]<br>• Engine stopped<br>• Selector lever: D<br>• Accelerator pedal: Fully depressed   | Less than 4.75 V  |
| 31<br>(O/L)                  | 48<br>(O)   | Throttle position sensor<br>1 (bank 2)    | Input            | [Ignition switch: ON]<br>• Engine stopped<br>• Selector lever: D<br>• Accelerator pedal: Fully released  | More than 0.36 V  |
|                              |             |   |                  | [Ignition switch: ON]<br>• Engine stopped<br>• Selector lever: D<br>• Accelerator pedal: Fully depressed   | Less than 4.75 V  |
| 33<br>(LG)                   | 128<br>(B)  | Heated oxygen sensor 2<br>heater (bank 2) | Output           | [Engine is running]<br>• Engine speed: Below 3,600 rpm after<br>the following conditions are met<br>- Engine: after warming up<br>- Keeping the engine speed between<br>3,500 and 4,000 rpm for 1 minute and at<br>idle for 1 minute under no load | 10 V★<br><br>5V/div JMBIA0037GB |
|                              |             |   |                  | [Ignition switch: ON]<br>• Engine stopped<br>[Engine is running]<br>• Engine speed: Above 3,600 rpm  | BATTERY VOLTAGE<br>(11 - 14 V)  |
| 34<br>(W/L)                  | 40<br>(O/L) | Throttle position sensor<br>2 (bank 1)    | Input            | [Ignition switch: ON]<br>• Engine stopped<br>• Selector lever: D<br>• Accelerator pedal: Fully released  | Less than 4.75 V  |
|                              |             |   |                  | [Ignition switch: ON]<br>• Engine stopped<br>• Selector lever: D<br>• Accelerator pedal: Fully depressed   | More than 0.36 V  |
| 35<br>(W)                    | 48<br>(O)   | Throttle position sensor<br>2 (bank 2)    | Input            | [Ignition switch: ON]<br>• Engine stopped<br>• Selector lever: D<br>• Accelerator pedal: Fully released  | Less than 4.75 V  |
|                              |             |   |                  | [Ignition switch: ON]<br>• Engine stopped<br>• Selector lever: D<br>• Accelerator pedal: Fully depressed   | More than 0.36 V  |

# ECM

< ECU DIAGNOSIS INFORMATION >

[VQ37VHR FOR USA AND CANADA]

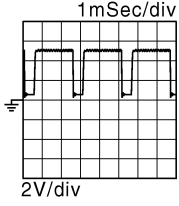
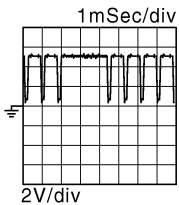
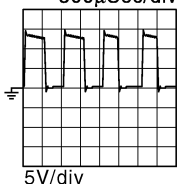
| Terminal No.<br>(Wire color) |             | Description   |                  | Condition  | Value<br>(Approx.)   |
|------------------------------|-------------|---|------------------|--|--|
| +                            | --          | Signal name   | Input/<br>Output |  |  |
| 37<br>(L)                    | 128<br>(B)  | Crankshaft position sensor (POS)                        | Input            | [Engine is running]<br>• Warm-up condition<br>• Idle speed<br><b>NOTE:</b><br>The pulse cycle changes depending on rpm at idle | 4.0 - 5.0 V★<br><br>JMBIA0041GB |
|                              |             |   |                  | [Engine is running]<br>• Engine speed: 2,000 rpm   | 4.0 - 5.0 V★<br><br>JMBIA0042GB |
| 38<br>(W)                    | 96<br>(O)   | Manifold absolute pressure (MAP) sensor                 | Input            | [Engine is running]<br>• Warm-up condition<br>• Idle speed   | 1.2 V  |
|                              |             |   |                  | [Engine is running]<br>• Warm-up condition<br>• Engine speed: 2,000 rpm  | 1.5 V  |
| 40<br>(O/L)                  | —           | Sensor ground [Throttle position sensor (bank 1)]       | —                | —  | —  |
| 43<br>(W/L)                  | 48<br>(O)   | Sensor power supply [Throttle position sensor (bank 2)] | —                | [Ignition switch: ON]  | 5 V  |
| 44<br>(W)                    | 40<br>(O/L) | Sensor power supply [Throttle position sensor (bank 1)] | —                | [Ignition switch: ON]  | 5 V  |
| 46<br>(R)                    | 128<br>(B)  | Sensor power supply [Crankshaft position sensor (POS)]  | —                | [Ignition switch: ON]  | 5 V  |
| 47<br>(B)                    | —           | Sensor ground [Crankshaft position sensor (POS)]        | —                | —  | —  |
| 48<br>(O)                    | —           | Sensor ground [Throttle position sensor (bank 2)]       | —                | —  | —  |
| 49<br>(LG)                   | 128<br>(B)  | Throttle control motor (Close) (bank 2)                 | Output           | [Ignition switch: ON]<br>• Engine stopped<br>• Selector lever: D<br>• Accelerator pedal: In the middle of releasing operation  | 0 - 14 V★<br><br>JMBIA0033GB  |

A  
EC  
C  
D  
E  
F  
G  
H  
I  
J  
K  
L  
M  
N  
O  
P

# ECM

< ECU DIAGNOSIS INFORMATION >

[VQ37VHR FOR USA AND CANADA]

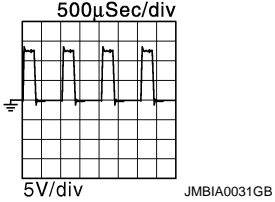
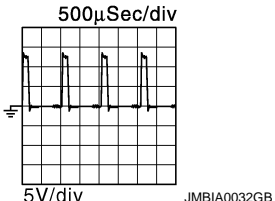
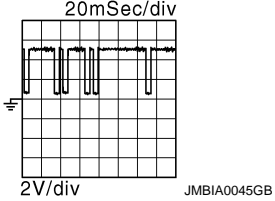
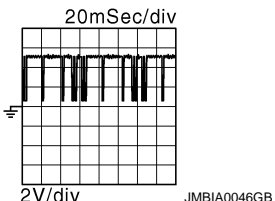
| Terminal No.<br>(Wire color) |            | Description  | Input/<br>Output | Condition   | Value<br>(Approx.)  |
|------------------------------|------------|--|------------------|---|---|
| +                            | --         | Signal name  |                  |   |   |
| 50<br>(V)                    | 128<br>(B) | Throttle control motor<br>(Open) (bank 2)  | Output           | [Ignition switch: ON]<br>• Engine stopped<br>• Selector lever: D<br>• Accelerator pedal: Fully depressed                          | 0 - 14 V★<br>      |
|                              |            |  |                  | [Ignition switch: ON]<br>• Engine stopped<br>• Selector lever: D<br>• Accelerator pedal: Fully released                           | 0 - 14 V★<br>      |
| 52<br>(R)                    | 128<br>(B) | Throttle control motor<br>power supply (bank 2)  | Input            | [Ignition switch: ON]   | BATTERY VOLTAGE<br>(11 - 14 V)  |
| 53<br>(G)                    | 128<br>(B) | Ignition switch  | Input            | [Ignition switch: OFF]  | 0 V   |
|                              |            |  |                  | [Ignition switch: ON]   | BATTERY VOLTAGE<br>(11 - 14 V)  |
| 54<br>(L)                    | —          | CAN communication line<br>[VVEL control module]  | Input/<br>output | —   | —   |
| 55<br>(Y)                    | —          | CAN communication line<br>[VVEL control module]  | Input/<br>output | —   | —   |
| 57<br>(L)                    | 128<br>(B) | A/F sensor 1 (bank 1)  | Input            | [Ignition switch: ON]   | 2.2 V   |
| 59<br>(L)                    | 128<br>(B) | Camshaft position sen-<br>sor (PHASE) (bank 1)   | Input            | [Engine is running]<br>• Warm-up condition<br>• Idle speed<br><b>NOTE:</b><br>The pulse cycle changes depending on<br>rpm at idle | 3.0 - 5.0 V★<br> |
|                              |            |  |                  | [Engine is running]<br>• Engine speed: 2,000 rpm  | 3.0 - 5.0 V★<br> |
| 60<br>(G)                    | 128<br>(B) | Sensor power supply<br>[Camshaft position sen-<br>sor (PHASE) (bank 1),<br>Manifold absolute pres-<br>sure (MAP) sensor, Pow-<br>er steering pressure<br>sensor] | —                | [Ignition switch: ON]   | 5 V   |
| 61<br>(B/W)                  | 128<br>(B) | A/F sensor 1 (bank 1)  | Input            | [Engine is running]<br>• Warm-up condition<br>• Engine speed: 2,000 rpm   | 1.8 V<br>Output voltage varies with air fuel<br>ratio.  |

# ECM

< ECU DIAGNOSIS INFORMATION >

[VQ37VHR FOR USA AND CANADA]

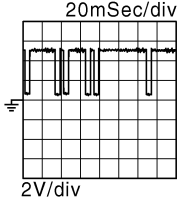
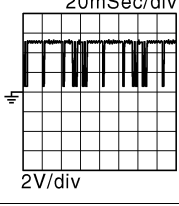
| Terminal No.<br>(Wire color) |            | Description  |                  | Condition   | Value<br>(Approx.)  |
|------------------------------|------------|--|------------------|---|---|
| +                            | --         | Signal name  | Input/<br>Output |   |   |
| 63<br>(BR)                   | 128<br>(B) | Camshaft position sensor (PHASE) (bank 2)  | Input            | [Engine is running]<br>• Warm-up condition<br>• Idle speed<br><b>NOTE:</b><br>The pulse cycle changes depending on rpm at idle  | 3.0 - 5.0 V★<br> JMBIA0045GB |
|                              |            |  |                  | [Engine is running]<br>• Engine speed: 2,000 rpm  | 3.0 - 5.0 V★<br> JMBIA0046GB |
| 64<br>(W)                    | 128<br>(B) | Sensor power supply<br>[Camshaft position sensor (PHASE) (bank 2), Battery current sensor] | —                | [Ignition switch: ON]   | 5 V   |
| 65<br>(L/O)                  | 128<br>(B) | A/F sensor 1 (bank 2)  | Input            | [Ignition switch: ON]   | 2.2 V   |
| 66<br>(W/L)                  | 128<br>(B) | A/F sensor 1 (bank 2)  | Input            | [Engine is running]<br>• Warm-up condition<br>• Engine speed: 2,000 rpm   | 1.8 V<br>Output voltage varies with air fuel ratio.   |
| 67<br>(Y)                    | 128<br>(B) | Intake air temperature sensor  | Input            | [Engine is running]   | 0 - 4.8 V<br>Output voltage varies with intake air temperature.   |
| 68<br>(V)                    | —          | Sensor ground<br>[Mass air flow sensor (bank 1), Intake air temperature sensor]            | —                | —   | —   |
| 69<br>(GR)                   | 128<br>(B) | Knock sensor (bank 2)  | Input            | [Engine is running]<br>• Idle speed   | 2.5 V*1   |
| 71<br>(SB)                   | 128<br>(B) | Engine coolant temperature sensor  | Input            | [Engine is running]   | 0 - 4.8 V<br>Output voltage varies with engine coolant temperature.   |
| 72<br>(—)                    | —          | Sensor ground<br>(Knock sensor)  | —                | —   | —   |
| 73<br>(W)                    | 128<br>(B) | Knock sensor (bank 1)  | Input            | [Engine is running]<br>• Idle speed   | 2.5 V*1   |
| 76<br>(BR)                   | 128<br>(B) | Heated oxygen sensor 2 (bank 1)  | Input            | [Engine is running]<br>• Revving engine from idle to 3,000 rpm quickly after the following conditions are met<br>- Engine: after warming up<br>- Keeping the engine speed between 3,500 and 4,000 rpm for 1 minute and at idle for 1 minute under no load | 0 - 1.0 V   |

A

EC

C

D

E

F

G

H

I

J

K

L

M

N

O

P

# ECM

< ECU DIAGNOSIS INFORMATION >

[VQ37VHR FOR USA AND CANADA]

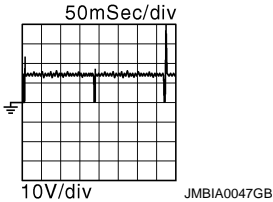
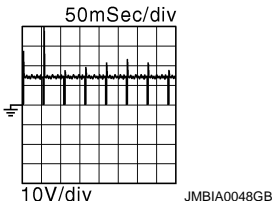
| Terminal No.<br>(Wire color) |                     | Description  |                  | Condition   | Value<br>(Approx.)   |
|------------------------------|---------------------|--|------------------|---|--|
| +                            | --                  | Signal name  | Input/<br>Output |   |  |
| 77<br>(O)                    | 68<br>(V)           | Mass air flow sensor<br>(bank 1)   | Input            | [Engine is running]<br>• Warm-up condition<br>• Idle speed  | 0.7 - 1.2 V  |
|                              |                     |  |                  | [Engine is running]<br>• Warm-up condition<br>• Engine speed: 2,500 rpm   | 1.3 - 1.7 V  |
| 78<br>(G)                    | 84<br>(B/W)         | Engine oil temperature<br>sensor   | Input            | [Engine is running]   | 0 - 4.8 V<br>Output voltage varies with engine<br>oil temperature.   |
| 79<br>(BR)                   | 94<br>(B)           | Mass air flow sensor<br>(bank 2)   | Input            | [Engine is running]<br>• Warm-up condition<br>• Idle speed  | 0.7 - 1.2 V  |
|                              |                     |  |                  | [Engine is running]<br>• Warm-up condition<br>• Engine speed: 2,500 rpm   | 1.3 - 1.7 V  |
| 80<br>(L)                    | 128<br>(B)          | Heated oxygen sensor 2<br>(bank 2)   | Input            | [Engine is running]<br>• Revving engine from idle to 3,000 rpm<br>quickly after the following conditions are<br>met<br>- Engine: after warming up<br>- Keeping the engine speed between<br>3,500 and 4,000 rpm for 1 minute and at<br>idle for 1 minute under no load | 0 - 1.0 V  |
| 81<br>(Y)                    | 128<br>(B)          | Fuel injector No. 3  | Output           | [Engine is running]<br>• Warm-up condition<br>• Idle speed<br><b>NOTE:</b><br>The pulse cycle changes depending on<br>rpm at idle   | BATTERY VOLTAGE<br>(11 - 14 V)★<br> |
| 82<br>(V)                    |                     | Fuel injector No. 6  |                  |   |  |
| 85<br>(BR)                   |                     | Fuel injector No. 2  |                  |   |  |
| 86<br>(R)                    |                     | Fuel injector No. 5  |                  |   |  |
| 89<br>(GR)                   |                     | Fuel injector No. 1  |                  |   |  |
| 90<br>(O)                    | Fuel injector No. 4 |  |                  | [Engine is running]<br>• Warm-up condition<br>• Engine speed: 2,000 rpm   | BATTERY VOLTAGE<br>(11 - 14 V)★<br> |
| 83<br>(GR)                   | 128<br>(B)          | Battery temperature<br>sensor  | Input            | [Engine is running]<br>• Battery: Fully charged*2<br>• Idle speed   | 1.6 V  |
| 84<br>(B/W)                  | —                   | Sensor ground<br>(Heated oxygen sensor<br>2, Engine coolant tem-<br>perature sensor, Engine<br>oil temperature sensor) | —                | —   | —  |
| 87<br>(V)                    | 96<br>(O)           | Power steering pressure<br>sensor  | Output           | [Engine is running]<br>• Steering wheel: Being turned   | 0.5 - 4.5 V  |
|                              |                     |  |                  | [Engine is running]<br>• Steering wheel: Not being turned   | 0.4 - 0.8 V  |

# ECM

< ECU DIAGNOSIS INFORMATION >

[VQ37VHR FOR USA AND CANADA]

| Terminal No.<br>(Wire color) |  | Description   |                  | Condition   | Value<br>(Approx.)             |
|------------------------------|--|---|------------------|---|--------------------------------|
| +                            | --   | Signal name   | Input/<br>Output |   |                                |
| 91<br>(G)                    | 95<br>(W)                                      | Battery current sensor  | Input            | [Engine is running]<br>• Battery: Fully charged*2<br>• Idle speed                 | 2.6 - 3.5 V                    |
| 92<br>(R)                    | —  | Sensor ground<br>[Camshaft position sensor (PHASE) (bank 2)]  | —                | —   | —                              |
| 93<br>(W)                    | 128<br>(B)                                     | Power supply for ECM<br>(Back-up)   | Input            | [Ignition switch: OFF]  | BATTERY VOLTAGE<br>(11 - 14 V) |
| 94<br>(B)                    | —  | Sensor ground<br>[Mass air flow sensor (bank 2)]  | —                | —   | —                              |
| 95<br>(W)                    | —  | Sensor ground<br>(Battery current sensor)   | —                | —   | —                              |
| 96<br>(O)                    | —  | Sensor ground<br>[Camshaft position sensor (PHASE) (bank 1), Manifold absolute pressure (MAP) sensor, Power steering pressure sensor] | —                | —   | —                              |
| 97<br>(R)                    | 100<br>(W)                                     | Accelerator pedal position sensor 1   | Input            | [Ignition switch: ON]<br>• Engine stopped<br>• Accelerator pedal: Fully released  | 0.45 - 1.00 V                  |
|                              |  |   |                  | [Ignition switch: ON]<br>• Engine stopped<br>• Accelerator pedal: Fully depressed | 4.2 - 4.8 V                    |
| 98<br>(Y)                    | 104<br>(BR) <sup>*3</sup><br>(B) <sup>*4</sup> | Accelerator pedal position sensor 2   | Input            | [Ignition switch: ON]<br>• Engine stopped<br>• Accelerator pedal: Fully released  | 0.22 - 0.50 V                  |
|                              |  |   |                  | [Ignition switch: ON]<br>• Engine stopped<br>• Accelerator pedal: Fully depressed | 2.1 - 2.5 V                    |
| 99<br>(G)                    | 100<br>(W)                                     | Sensor power supply<br>(Accelerator pedal position sensor 1)  | —                | [Ignition switch: ON]   | 5 V                            |
| 100<br>(W)                   | —  | Sensor ground<br>(Accelerator pedal position sensor 1)  | —                | —   | —                              |

A  
EC  
C  
D  
E  
F  
G  
H  
I  
J  
K  
L  
M  
N  
O  
P

# ECM

< ECU DIAGNOSIS INFORMATION >

[VQ37VHR FOR USA AND CANADA]

| Terminal No.<br>(Wire color)                   |  | Description   | Input/<br>Output | Condition   | Value<br>(Approx.)   |
|--|--|---|------------------|---|--|
| +  | --   | Signal name   |                  |   |  |
| 101<br>(SB)                                    | 108<br>(Y)                                     | ICC steering switch<br>(models with ICC system)   | Input            | [Ignition switch: ON]<br>• ICC steering switch: OFF   | 4.2 V  |
|  |  |   |                  | [Ignition switch: ON]<br>• MAIN switch: Pressed   | 0 V  |
|  |  |   |                  | [Ignition switch: ON]<br>• DYNAMIC DRIVE ASSISTANCE SYSTEMS switch: Pressed   | 1.0 V  |
|  |  |   |                  | [Ignition switch: ON]<br>• CANCEL switch: Pressed   | 1.9 V  |
|  |  |   |                  | [Ignition switch: ON]<br>• RESUME/ACCELERATE switch: Pressed  | 3.7 V  |
|  |  |   |                  | [Ignition switch: ON]<br>• SET/COAST switch: Pressed  | 3.2 V  |
| 101<br>(SB)                                    | 108<br>(Y)                                     | ASCD steering switch<br>(models with ASCD system)   | Input            | [Ignition switch: ON]<br>• ASCD steering switch: OFF  | 4 V  |
|  |  |   |                  | [Ignition switch: ON]<br>• MAIN switch: Pressed   | 0 V  |
|  |  |   |                  | [Ignition switch: ON]<br>• CANCEL switch: Pressed   | 1 V  |
|  |  |   |                  | [Ignition switch: ON]<br>• RESUME/ACCELERATE switch: Pressed  | 3 V  |
|  |  |   |                  | [Ignition switch: ON]<br>• SET/COAST switch: Pressed  | 2 V  |
| 102<br>(P)                                     | 112<br>(V)                                     | EVAP control system pressure sensor   | Input            | [Ignition switch: ON]   | 1.8 - 4.8 V  |
| 103<br>(L)                                     | 104<br>(BR) <sup>*3</sup><br>(B) <sup>*4</sup> | Sensor power supply<br>(Accelerator pedal position sensor 2)                              | —                | [Ignition switch: ON]   | 5 V  |
| 104<br>(BR) <sup>*3</sup><br>(B) <sup>*4</sup> | —  | Sensor ground<br>(Accelerator pedal position sensor 2)                                    | —                | —   | —  |
| 105<br>(LG)                                    | 112<br>(V)                                     | Refrigerant pressure sensor   | Input            | [Engine is running]<br>• Warm-up condition<br>• Both A/C switch and blower fan motor switch: ON (Compressor operates) | 1.0 - 4.0 V  |
| 106<br>(P)                                     | 128<br>(B)                                     | Fuel tank temperature sensor  | Input            | [Engine is running]   | 0 - 4.8 V<br>Output voltage varies with fuel tank temperature. |
| 107<br>(BG)                                    | 112<br>(V)                                     | Sensor power supply<br>(EVAP control system pressure sensor, Refrigerant pressure sensor) | —                | [Ignition switch: ON]   | 5 V  |
| 108<br>(Y)                                     | —  | Sensor ground<br>(ASCD/ICC steering switch)   | —                | —   | —  |



# ECM

< ECU DIAGNOSIS INFORMATION >

[VQ37VHR FOR USA AND CANADA]

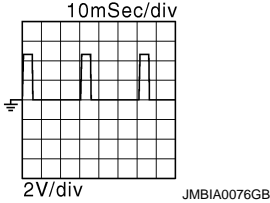
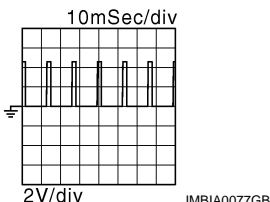
| Terminal No.<br>(Wire color) |            | Description  |                  | Condition  | Value<br>(Approx.)  |
|------------------------------|------------|--|------------------|--|---|
| +                            | --         | Signal name  | Input/<br>Output |  |   |
| 109<br>(BR)                  | 128<br>(B) | PNP signal   | Input            | [Ignition switch: ON]<br>• Selector lever: P or N  | BATTERY VOLTAGE<br>(11 - 14 V)  |
|                              |            |  |                  | [Ignition switch: ON]<br>• Selector lever: Except above  | 0 V   |
| 110<br>(V)                   | 128<br>(B) | Engine speed output signal   | Output           | [Engine is running]<br>• Warm-up condition<br>• Idle speed<br><b>NOTE:</b><br>The pulse cycle changes depending on rpm at idle | 1 V★<br> |
|                              |            |  |                  | [Engine is running]<br>• Engine speed is 2,000 rpm   | 1 V★<br> |
| 112<br>(V)                   | —          | Sensor ground<br>(EVAP control system pressure sensor, Refrigerant pressure sensor)        | —                | —  | —   |
| 113<br>(P)                   | —          | CAN communication line   | Input/<br>Output | —  | —   |
| 114<br>(L)                   | —          | CAN communication line   | Input/<br>Output | —  | —   |
| 117<br>(V)                   | 128<br>(B) | Data link connector  | Input/<br>Output | —  | —   |
| 121<br>(G)                   | 128<br>(B) | EVAP canister vent control valve   | Output           | [Ignition switch: ON]  | BATTERY VOLTAGE<br>(11 - 14 V)  |
| 122<br>(P)                   | 128<br>(B) | Stop lamp switch   | Input            | [Ignition switch: OFF]<br>• Brake pedal: Fully released  | 0 V   |
|                              |            |  |                  | [Ignition switch: OFF]<br>• Brake pedal: Slightly depressed  | BATTERY VOLTAGE<br>(11 - 14 V)  |
| 123<br>(B)<br>124<br>(B)     | —          | ECM ground   | —                | —  | —   |
| 125<br>(SB)                  | 128<br>(B) | Power supply for ECM   | Input            | [Ignition switch: ON]  | BATTERY VOLTAGE<br>(11 - 14 V)  |
| 126<br>(BR)                  | 128<br>(B) | ICC brake switch (models with ICC system)<br>ASCDC brake switch (models with ASCDC system) | Input            | [Ignition switch: ON]<br>• Brake pedal: Slightly depressed   | 0 V   |
|                              |            |  |                  | [Ignition switch: ON]<br>• Brake pedal: Fully released   | BATTERY VOLTAGE<br>(11 - 14 V)  |
| 127<br>(B)<br>128<br>(B)     | —          | ECM ground   | —                | —  | —   |

★: Average voltage for pulse signal (Actual pulse signal can be confirmed by oscilloscope.)

\*1: This may vary depending on internal resistance of the tester.

# ECM

< ECU DIAGNOSIS INFORMATION >

[VQ37VHR FOR USA AND CANADA]

\*2: Before measuring the terminal voltage, confirm that the battery is fully charged. Refer to [PG-135. "How to Handle Battery"](#).

\*3: With ICC

\*4: Without ICC

## Fail safe

INFOID:000000006882817

### NON DTC RELATED ITEM

| Engine operating condition in fail-safe mode                       | Detected items                     | Remarks   | Reference page         |
|--|------------------------------------|---|------------------------|
| Engine speed will not rise more than 2,500 rpm due to the fuel cut | Malfunction indicator lamp circuit | When there is an open circuit on MIL circuit, the ECM cannot warn the driver by illuminating MIL when there is malfunction on engine control system.<br>Therefore, when electrical controlled throttle and part of ECM related diagnoses are continuously detected as NG for 5 trips, ECM warns the driver that engine control system malfunctions and MIL circuit is open by means of operating the fail-safe function.<br>The fail-safe function also operates when above diagnoses except MIL circuit are detected and demands the driver to repair the malfunction. | <a href="#">EC-524</a> |

### DTC RELATED ITEM

| DTC No.  | Detected items                            | Engine operating condition in fail-safe mode  |  |
|--|---|---|--|
| U1003<br>U1024   | Can communication circuit                 | VVEL actuator motor relay is turned off, and VVEL value is become at a minimum angle.<br>Engine speed will not rise more than 3,500 rpm due to the fuel cut.  |  |
| P0011<br>P0021   | Intake valve timing control               | The signal is not energized to the intake valve timing control solenoid valve and the valve control does not function.  |  |
| P0102<br>P0103<br>P010C<br>P010D   | Mass air flow sensor circuit              | Engine speed will not rise more than 2,400 rpm due to the fuel cut.   |  |
| P0117<br>P0118   | Engine coolant temperature sensor circuit | Engine coolant temperature will be determined by ECM based on the following condition.<br>CONSULT displays the engine coolant temperature decided by ECM.   |  |
|  |   | Condition   | Engine coolant temperature decided (CONSULT display) |
|  |   | Just as ignition switch is turned ON or START   | 40°C (104°F)   |
|  |   | Approx 4 minutes or more after engine starting  | 80°C (176°F)   |
|  |   | Except as shown above   | 40 - 80°C (104 - 176°F)<br>(Depends on the time)     |
|  |   | When the fail-safe system for engine coolant temperature sensor is activated, the cooling fan operates while engine is running.   |  |
| P0122<br>P0123<br>P0222<br>P0223<br>P0227<br>P0228<br>P1239<br>P2132<br>P2133<br>P2135 | Throttle position sensor                  | The ECM controls the electric throttle control actuator in regulating the throttle opening in order for the idle position to be within +10 degrees.<br>The ECM regulates the opening speed of the throttle valve to be slower than the normal condition.<br>Therefore, the acceleration will be poor. |  |
| P0500  | Vehicle speed sensor                      | The cooling fan operates (Highest) while engine is running.   |  |
| P0524  | Engine oil pressure                       | The signal is not energized to the intake valve timing control solenoid valve and the valve control does not function.<br>Engine speed will not rise more than 2,400 rpm due to the fuel cut.   |  |

# ECM

## < ECU DIAGNOSIS INFORMATION >

## [VQ37VHR FOR USA AND CANADA]

| DTC No.                                   | Detected items                     | Engine operating condition in fail-safe mode   |                   |
|---|------------------------------------|--|-------------------|
| P0605                                     | ECM                                | (When ECM calculation function is malfunctioning:<br>ECM stops the electric throttle control actuator control, throttle valve is maintained at a fixed opening (approx. 5 degrees) by the return spring.<br>ECM deactivates ASCD operation.  |                   |
| P0607                                     | ECM                                | VVEL actuator motor relay is turned off, and VVEL value is become at a minimum angle.<br>Engine speed will not rise more than 2,500 rpm due to the fuel cut.   |                   |
| P0643                                     | Sensor power supply                | ECM stops the electric throttle control actuator control, throttle valve is maintained at a fixed opening (approx. 5 degrees) by the return spring.  |                   |
| P1087<br>P1088                            | VVEL control function              | VVEL of normal bank is controlled at VVEL angle of abnormal bank.<br>Engine speed will not rise more than 3,500 rpm due to the fuel cut.   |                   |
| P1089<br>P1092                            | VVEL control shaft position sensor | VVEL value is maintained at a fixed angle.<br>Engine speed will not rise more than 3,500 rpm due to the fuel cut   |                   |
| P1608                                     | VVEL control shaft position sensor | VVEL actuator motor relay is turned off, and VVEL value is become at a minimum angle.<br>Engine speed will not rise more than 3,500 rpm due to the fuel cut  |                   |
| P1090<br>P1093                            | VVEL actuator motor                | VVEL of normal bank is controlled at VVEL angle of abnormal bank.<br>Engine speed will not rise more than 3,500 rpm due to the fuel cut.<br><br>VVEL actuator motor relay is turned off, and VVEL value is become at a minimum angle.<br>Engine speed will not rise more than 3,500 rpm due to the fuel cut. |                   |
| P1091                                     | VVEL actuator motor relay          | VVEL actuator motor relay is turned off, and VVEL value is become at a minimum angle.<br>Engine speed will not rise more than 3,500 rpm due to the fuel cut.   |                   |
| P1233<br>P2101                            | Electric throttle control function | ECM stops the electric throttle control actuator control, throttle valve is maintained at a fixed opening (approx. 5 degrees) by the return spring.  |                   |
| P1236<br>P2118                            | Throttle control motor             | ECM stops the electric throttle control actuator control, throttle valve is maintained at a fixed opening (approx. 5 degrees) by the return spring.  |                   |
| P1238<br>P2119                            | Electric throttle control actuator | (When electric throttle control actuator does not function properly due to the return spring malfunction:)<br>ECM controls the electric throttle actuator by regulating the throttle opening around the idle position. The engine speed will not rise more than 2,000 rpm.                                   |                   |
|   |                                    | (When throttle valve opening angle in fail-safe mode is not in specified range:)<br>ECM controls the electric throttle control actuator by regulating the throttle opening to 20 degrees or less.  |                   |
|   |                                    | (When ECM detects the throttle valve is stuck open:)<br>While the vehicle is being driven, it slows down gradually because of fuel cut. After the vehicle stops, the engine stalls.<br>The engine can restart in N or P position, and engine speed will not exceed 1,000 rpm or more.                        |                   |
| P1290<br>P2100<br>P2103                   | Throttle control motor relay       | ECM stops the electric throttle control actuator control, throttle valve is maintained at a fixed opening (approx. 5 degrees) by the return spring.  |                   |
| P1606                                     | VVEL control module                | VVEL actuator motor relay is turned off, and VVEL value is become at a minimum angle.<br>Engine speed will not rise more than 3,500 rpm due to the fuel cut.   |                   |
| P1805                                     | Brake switch                       | ECM controls the electric throttle control actuator by regulating the throttle opening to a small range.<br>Therefore, acceleration will be poor.  |                   |
|   |                                    | Vehicle condition  | Driving condition |
|   |                                    | When engine is idling  | Normal            |
|   | When accelerating                  | Poor acceleration  |                   |
| P2122<br>P2123<br>P2127<br>P2128<br>P2138 | Accelerator pedal position sensor  | The ECM controls the electric throttle control actuator in regulating the throttle opening in order for the idle position to be within +10 degrees.<br>The ECM regulates the opening speed of the throttle valve to be slower than the normal condition.<br>Therefore, the acceleration will be poor.        |                   |

A

EC

C

D

E

F

G

H

I

J

K

L

M

N

O

P

## DTC Inspection Priority Chart

If some DTCs are displayed at the same time, perform inspections one by one based on the following priority chart.

| Priority | Detected items (DTC)  |
|----------|---|
| 1        | <ul style="list-style-type: none"> <li>• U0101 U1001 U1003 CAN communication line</li> <li>• U1024 VVEL CAN communication line</li> <li>• P0102 P0103 P010C P010D Mass air flow sensor</li> <li>• P010A Manifold absolute pressure (MAP) sensor</li> <li>• P0111 P0112 P0113 P0127 Intake air temperature sensor</li> <li>• P0117 P0118 P0125 Engine coolant temperature sensor</li> <li>• P0122 P0123 P0222 P0223 P0227 P0228 P1225 P1226 P1234 P1235 P1239 P2132 P2133 P2135 Throttle position sensor</li> <li>• P0128 Thermostat function</li> <li>• P0181 P0182 P0183 Fuel tank temperature sensor</li> <li>• P0196 P0197 P0198 Engine oil temperature sensor</li> <li>• P0327 P0328 P0332 P0333 Knock sensor</li> <li>• P0335 Crankshaft position sensor (POS)</li> <li>• P0340 P0345 Camshaft position sensor (PHASE)</li> <li>• P0460 P0461 P0462 P0463 Fuel level sensor</li> <li>• P0500 Vehicle speed sensor</li> <li>• P0605 P0607 ECM</li> <li>• P0643 Sensor power supply</li> <li>• P0700 TCM</li> <li>• P0705 Transmission range switch</li> <li>• P0850 Park/neutral position (PNP) switch</li> <li>• P1089 P1092 P1608 VVEL control shaft position sensor</li> <li>• P1606 P1607 VVEL control module</li> <li>• P1550 P1551 P1552 P1553 P1554 Battery current sensor</li> <li>• P1556 P1557 Battery temperature sensor</li> <li>• P1610 - P1615 NATS</li> <li>• P2122 P2123 P2127 P2128 P2138 Accelerator pedal position sensor</li> </ul> |

| Priority | Detected items (DTC)  |
|----------|---|
| 2        | <ul style="list-style-type: none"> <li>• P0031 P0032 P0051 P0052 Air fuel ratio (A/F) sensor 1 heater</li> <li>• P0037 P0038 P0057 P0058 Heated oxygen sensor 2 heater</li> <li>• P0075 P0081 Intake valve timing control solenoid valve</li> <li>• P0130 P0131 P0132 P0133 P0150 P0151 P0152 P0153 P2A00 P2A03 Air fuel ratio (A/F) sensor 1</li> <li>• P0137 P0138 P0139 P0157 P0158 P0159 Heated oxygen sensor 2</li> <li>• P0441 EVAP control system purge flow monitoring</li> <li>• P0443 P0444 P0445 EVAP canister purge volume control solenoid valve</li> <li>• P0447 P0448 EVAP canister vent control valve</li> <li>• P0451 P0452 P0453 EVAP control system pressure sensor</li> <li>• P0550 Power steering pressure sensor</li> <li>• P0603 ECM power supply</li> <li>• P0710 P0717 P0720 P0731 P0732 P0733 P0734 P0735 P0740 P0744 P0745 P0750 P0775 P0780 P0795 P1730 P1734 P2713 P2722 P2731 P2807 A/T related sensors, solenoid valves and switches</li> <li>• P1087 P1088 VVEL system</li> <li>• P1090 P1093 VVEL actuator motor</li> <li>• P1091 VVEL actuator motor relay</li> <li>• P1217 Engine over temperature (OVERHEAT)</li> <li>• P1233 P2101 Electric throttle control function</li> <li>• P1236 P2118 Throttle control motor</li> <li>• P1290 P2100 P2103 Throttle control motor relay</li> <li>• P1805 Brake switch</li> </ul> |
| 3        | <ul style="list-style-type: none"> <li>• P0011 P0021 Intake valve timing control</li> <li>• P006A P0101 P010B Mass air flow sensor</li> <li>• P0106 Manifold absolute pressure (MAP) sensor</li> <li>• P0171 P0172 P0174 P0175 Fuel injection system function</li> <li>• P0300 - P0306 Misfire</li> <li>• P0420 P0430 Three way catalyst function</li> <li>• P0456 EVAP control system (VERY SMALL LEAK)</li> <li>• P0506 P0507 Idle speed control system</li> <li>• P050A P050E Cold start control</li> <li>• P0524 Engine oil pressure</li> <li>• P100A P100B VVEL system</li> <li>• P1148 P1168 Closed loop control</li> <li>• P1211 TCS control unit</li> <li>• P1212 TCS communication line</li> <li>• P1238 P2119 Electric throttle control actuator</li> <li>• P1564 ICC steering switch / ASCD steering switch</li> <li>• P1568 ICC command value</li> <li>• P1572 ICC brake switch / ASCD brake switch</li> <li>• P1574 ICC vehicle speed sensor / ASCD vehicle speed sensor</li> </ul>  |

A  
EC  
C  
D  
E  
F  
G  
H  
I  
J  
K  
L

DTC Index

INFOID:000000006882819

×:Applicable —: Not applicable

| DTC*1            |             | Items<br>(CONSULT screen terms)                                     | SRT<br>code | Trip                                     | MIL               | Permanent<br>DTC group*4 | Reference<br>page      |
|------------------|-------------|---|-------------|--|-------------------|--------------------------|------------------------|
| CONSULT<br>GST*2 | ECM*3       |   |             |  |                   |                          |                        |
| U0101            | 0101*5      | CAN COMM CIRCUIT  | —           | 1  | ×                 | B                        | <a href="#">EC-185</a> |
| U1001            | 1001*5      | CAN COMM CIRCUIT  | —           | 2<br>(with ASCD)<br>1 or 2<br>(with ICC) | —                 | —                        | <a href="#">EC-186</a> |
| U1003            | 1003        | CAN COMM CIRCUIT  | —           | 2  | —                 | —                        | <a href="#">EC-187</a> |
| U1024            | 1024        | VVEL CAN COMM CIRCUIT   | —           | 1  | ×                 | B                        | <a href="#">EC-189</a> |
| <b>P0000</b>     | <b>0000</b> | <b>NO DTC IS DETECTED.<br/>FURTHER TESTING MAY BE<br/>REQUIRED.</b> | —           | —  | <b>Flashing*8</b> | —                        | —                      |
| P0011            | 0011        | INT/V TIM CONT-B1   | —           | 2  | ×                 | B                        | <a href="#">EC-191</a> |
| P0021            | 0021        | INT/V TIM CONT-B2   | —           | 2  | ×                 | B                        | <a href="#">EC-191</a> |

M  
N  
O  
P

# ECM

< ECU DIAGNOSIS INFORMATION >

[VQ37VHR FOR USA AND CANADA]

| DTC*1            |       | Items<br>(CONSULT screen terms) | SRT<br>code | Trip | MIL | Permanent<br>DTC group*4 | Reference<br>page      |
|------------------|-------|---------------------------------|-------------|------|-----|--------------------------|------------------------|
| CONSULT<br>GST*2 | ECM*3 |                                 |             |      |     |                          |                        |
| P0031            | 0031  | A/F SEN1 HTR (B1)               | —           | 2    | ×   | B                        | <a href="#">EC-195</a> |
| P0032            | 0032  | A/F SEN1 HTR (B1)               | —           | 2    | ×   | B                        | <a href="#">EC-195</a> |
| P0037            | 0037  | HO2S2 HTR (B1)                  | —           | 2    | ×   | B                        | <a href="#">EC-198</a> |
| P0038            | 0038  | HO2S2 HTR (B1)                  | —           | 2    | ×   | B                        | <a href="#">EC-198</a> |
| P0051            | 0051  | A/F SEN1 HTR (B2)               | —           | 2    | ×   | B                        | <a href="#">EC-195</a> |
| P0052            | 0052  | A/F SEN1 HTR (B2)               | —           | 2    | ×   | B                        | <a href="#">EC-195</a> |
| P0057            | 0057  | HO2S2 HTR (B2)                  | —           | 2    | ×   | B                        | <a href="#">EC-198</a> |
| P0058            | 0058  | HO2S2 HTR (B2)                  | —           | 2    | ×   | B                        | <a href="#">EC-198</a> |
| P006A            | 006A  | MAP-MAF CORELTION-B1            | —           | 2    | ×   | B                        | <a href="#">EC-201</a> |
| P0075            | 0075  | INT/V TIM V/CIR-B1              | —           | 2    | ×   | B                        | <a href="#">EC-208</a> |
| P0081            | 0081  | INT/V TIM V/CIR-B2              | —           | 2    | ×   | B                        | <a href="#">EC-208</a> |
| P0101            | 0101  | MAF SEN/CIRCUIT-B1              | —           | 2    | ×   | B                        | <a href="#">EC-201</a> |
| P0102            | 0102  | MAF SEN/CIRCUIT-B1              | —           | 1    | ×   | B                        | <a href="#">EC-211</a> |
| P0103            | 0103  | MAF SEN/CIRCUIT-B1              | —           | 1    | ×   | B                        | <a href="#">EC-211</a> |
| P0106            | 0106  | ABSL PRES SEN/CIRC              | —           | 2    | ×   | B                        | <a href="#">EC-217</a> |
| P010A            | 010A  | ABSL PRES SEN/CIRC              | —           | 2    | ×   | B                        | <a href="#">EC-221</a> |
| P010B            | 010B  | MAF SEN/CIRCUIT-B2              | —           | 2    | ×   | B                        | <a href="#">EC-201</a> |
| P010C            | 010C  | MAF SEN/CIRCUIT-B2              | —           | 1    | ×   | B                        | <a href="#">EC-211</a> |
| P010D            | 010D  | MAF SEN/CIRCUIT-B2              | —           | 1    | ×   | B                        | <a href="#">EC-211</a> |
| P0111            | 0111  | IAT SENSOR                      | —           | 2    | ×   | A                        | <a href="#">EC-224</a> |
| P0112            | 0112  | IAT SEN/CIRCUIT-B1              | —           | 2    | ×   | B                        | <a href="#">EC-226</a> |
| P0113            | 0113  | IAT SEN/CIRCUIT-B1              | —           | 2    | ×   | B                        | <a href="#">EC-226</a> |
| P0116            | 0116  | ECT SEN/CIRC                    | —           | 2    | ×   | A                        | <a href="#">EC-228</a> |
| P0117            | 0117  | ECT SEN/CIRC                    | —           | 1    | ×   | B                        | <a href="#">EC-231</a> |
| P0118            | 0118  | ECT SEN/CIRC                    | —           | 1    | ×   | B                        | <a href="#">EC-231</a> |
| P0122            | 0122  | TP SEN 2/CIRC-B1                | —           | 1    | ×   | B                        | <a href="#">EC-233</a> |
| P0123            | 0123  | TP SEN 2/CIRC-B1                | —           | 1    | ×   | B                        | <a href="#">EC-233</a> |
| P0125            | 0125  | ECT SENSOR                      | —           | 2    | ×   | B                        | <a href="#">EC-236</a> |
| P0127            | 0127  | IAT SENSOR-B1                   | —           | 2    | ×   | B                        | <a href="#">EC-238</a> |
| P0128            | 0128  | THERMSTAT FNCTN                 | —           | 2    | ×   | A                        | <a href="#">EC-240</a> |
| P0130            | 0130  | A/F SENSOR1 (B1)                | —           | 2    | ×   | A                        | <a href="#">EC-243</a> |
| P0131            | 0131  | A/F SENSOR1 (B1)                | —           | 2    | ×   | B                        | <a href="#">EC-247</a> |
| P0132            | 0132  | A/F SENSOR1 (B1)                | —           | 2    | ×   | B                        | <a href="#">EC-250</a> |
| P0133            | 0133  | A/F SENSOR1 (B1)                | ×           | 2    | ×   | A                        | <a href="#">EC-253</a> |
| P0137            | 0137  | HO2S2 (B1)                      | ×           | 2    | ×   | A                        | <a href="#">EC-258</a> |
| P0138            | 0138  | HO2S2 (B1)                      | ×           | 2    | ×   | A                        | <a href="#">EC-264</a> |
| P0139            | 0139  | HO2S2 (B1)                      | ×           | 2    | ×   | A                        | <a href="#">EC-272</a> |
| P0150            | 0150  | A/F SENSOR1 (B2)                | —           | 2    | ×   | A                        | <a href="#">EC-243</a> |
| P0151            | 0151  | A/F SENSOR1 (B2)                | —           | 2    | ×   | B                        | <a href="#">EC-247</a> |
| P0152            | 0152  | A/F SENSOR1 (B2)                | —           | 2    | ×   | B                        | <a href="#">EC-250</a> |
| P0153            | 0153  | A/F SENSOR1 (B2)                | ×           | 2    | ×   | A                        | <a href="#">EC-253</a> |
| P0157            | 0157  | HO2S2 (B2)                      | ×           | 2    | ×   | A                        | <a href="#">EC-258</a> |

# ECM

< ECU DIAGNOSIS INFORMATION >

[VQ37VHR FOR USA AND CANADA]

| DTC*1            |       | Items<br>(CONSULT screen terms) | SRT<br>code | Trip   | MIL | Permanent<br>DTC group*4 | Reference<br>page      |    |
|------------------|-------|---------------------------------|-------------|--------|-----|--------------------------|------------------------|----|
| CONSULT<br>GST*2 | ECM*3 |                                 |             |        |     |                          |                        |    |
| P0158            | 0158  | HO2S2 (B2)                      | ×           | 2      | ×   | A                        | <a href="#">EC-264</a> | EC |
| P0159            | 0159  | HO2S2 (B2)                      | ×           | 2      | ×   | A                        | <a href="#">EC-272</a> |    |
| P0171            | 0171  | FUEL SYS-LEAN-B1                | —           | 2      | ×   | B                        | <a href="#">EC-279</a> |    |
| P0172            | 0172  | FUEL SYS-RICH-B1                | —           | 2      | ×   | B                        | <a href="#">EC-283</a> | C  |
| P0174            | 0174  | FUEL SYS-LEAN-B2                | —           | 2      | ×   | B                        | <a href="#">EC-279</a> |    |
| P0175            | 0175  | FUEL SYS-RICH-B2                | —           | 2      | ×   | B                        | <a href="#">EC-283</a> | D  |
| P0181            | 0181  | FTT SENSOR                      | —           | 2      | ×   | A and B                  | <a href="#">EC-287</a> |    |
| P0182            | 0182  | FTT SEN/CIRCUIT                 | —           | 2      | ×   | B                        | <a href="#">EC-291</a> |    |
| P0183            | 0183  | FTT SEN/CIRCUIT                 | —           | 2      | ×   | B                        | <a href="#">EC-291</a> | E  |
| P0196            | 0196  | EOT SENSOR                      | —           | 2      | ×   | A and B                  | <a href="#">EC-294</a> |    |
| P0197            | 0197  | EOT SEN/CIRC                    | —           | 2      | ×   | B                        | <a href="#">EC-298</a> |    |
| P0198            | 0198  | EOT SEN/CIRC                    | —           | 2      | ×   | B                        | <a href="#">EC-298</a> | F  |
| P0222            | 0222  | TP SEN 1/CIRC-B1                | —           | 1      | ×   | B                        | <a href="#">EC-300</a> |    |
| P0223            | 0223  | TP SEN 1/CIRC-B1                | —           | 1      | ×   | B                        | <a href="#">EC-300</a> | G  |
| P0227            | 0227  | TP SEN 2/CIRC-B2                | —           | 1      | ×   | B                        | <a href="#">EC-233</a> |    |
| P0228            | 0228  | TP SEN 2/CIRC-B2                | —           | 1      | ×   | B                        | <a href="#">EC-233</a> |    |
| P0300            | 0300  | MULTI CYL MISFIRE               | —           | 1 or 2 | ×   | B                        | <a href="#">EC-303</a> | H  |
| P0301            | 0301  | CYL 1 MISFIRE                   | —           | 1 or 2 | ×   | B                        | <a href="#">EC-303</a> |    |
| P0302            | 0302  | CYL 2 MISFIRE                   | —           | 1 or 2 | ×   | B                        | <a href="#">EC-303</a> | I  |
| P0303            | 0303  | CYL 3 MISFIRE                   | —           | 1 or 2 | ×   | B                        | <a href="#">EC-303</a> |    |
| P0304            | 0304  | CYL 4 MISFIRE                   | —           | 1 or 2 | ×   | B                        | <a href="#">EC-303</a> |    |
| P0305            | 0305  | CYL 5 MISFIRE                   | —           | 1 or 2 | ×   | B                        | <a href="#">EC-303</a> | J  |
| P0306            | 0306  | CYL 6 MISFIRE                   | —           | 1 or 2 | ×   | B                        | <a href="#">EC-303</a> |    |
| P0327            | 0327  | KNOCK SEN/CIRC-B1               | —           | 2      | —   | —                        | <a href="#">EC-309</a> |    |
| P0328            | 0328  | KNOCK SEN/CIRC-B1               | —           | 2      | —   | —                        | <a href="#">EC-309</a> | K  |
| P0332            | 0332  | KNOCK SEN/CIRC-B2               | —           | 2      | —   | —                        | <a href="#">EC-309</a> |    |
| P0333            | 0333  | KNOCK SEN/CIRC-B2               | —           | 2      | —   | —                        | <a href="#">EC-309</a> | L  |
| P0335            | 0335  | CKP SEN/CIRCUIT                 | —           | 2      | ×   | B                        | <a href="#">EC-312</a> |    |
| P0340            | 0340  | CMP SEN/CIRC-B1                 | —           | 2      | ×   | B                        | <a href="#">EC-316</a> |    |
| P0345            | 0345  | CMP SEN/CIRC-B2                 | —           | 2      | ×   | B                        | <a href="#">EC-316</a> | M  |
| P0420            | 0420  | TW CATALYST SYS-B1              | ×           | 2      | ×   | A                        | <a href="#">EC-321</a> |    |
| P0430            | 0430  | TW CATALYST SYS-B2              | ×           | 2      | ×   | A                        | <a href="#">EC-321</a> | N  |
| P0441            | 0441  | EVAP PURG FLOW/MON              | ×           | 2      | ×   | A                        | <a href="#">EC-326</a> |    |
| P0443            | 0443  | PURG VOLUME CONT/V              | —           | 2      | ×   | A                        | <a href="#">EC-331</a> |    |
| P0444            | 0444  | PURG VOLUME CONT/V              | —           | 2      | ×   | B                        | <a href="#">EC-335</a> | O  |
| P0445            | 0445  | PURG VOLUME CONT/V              | —           | 2      | ×   | B                        | <a href="#">EC-335</a> |    |
| P0447            | 0447  | VENT CONTROL VALVE              | —           | 2      | ×   | B                        | <a href="#">EC-338</a> | P  |
| P0448            | 0448  | VENT CONTROL VALVE              | —           | 2      | ×   | B                        | <a href="#">EC-342</a> |    |
| P0451            | 0451  | EVAP SYS PRES SEN               | —           | 2      | ×   | A                        | <a href="#">EC-346</a> |    |
| P0452            | 0452  | EVAP SYS PRES SEN               | —           | 2      | ×   | B                        | <a href="#">EC-350</a> |    |
| P0453            | 0453  | EVAP SYS PRES SEN               | —           | 2      | ×   | B                        | <a href="#">EC-355</a> |    |
| P0456            | 0456  | EVAP VERY SML LEAK              | ×*7         | 2      | ×   | A                        | <a href="#">EC-360</a> |    |

# ECM

< ECU DIAGNOSIS INFORMATION >

[VQ37VHR FOR USA AND CANADA]

| DTC*1            |       | Items<br>(CONSULT screen terms) | SRT<br>code | Trip   | MIL    | Permanent<br>DTC group*4 | Reference<br>page      |
|------------------|-------|---------------------------------|-------------|--------|--------|--------------------------|------------------------|
| CONSULT<br>GST*2 | ECM*3 |                                 |             |        |        |                          |                        |
| P0460            | 0460  | FUEL LEV SEN SLOSH              | —           | 2      | ×      | A                        | <a href="#">EC-366</a> |
| P0461            | 0461  | FUEL LEVEL SENSOR               | —           | 2      | ×      | B                        | <a href="#">EC-367</a> |
| P0462            | 0462  | FUEL LEVL SEN/CIRC              | —           | 2      | ×      | B                        | <a href="#">EC-369</a> |
| P0463            | 0463  | FUEL LEVL SEN/CIRC              | —           | 2      | ×      | B                        | <a href="#">EC-369</a> |
| P0500            | 0500  | VEHICLE SPEED SENSOR A*6        | —           | 2      | ×      | B                        | <a href="#">EC-370</a> |
| P0506            | 0506  | ISC SYSTEM                      | —           | 2      | ×      | B                        | <a href="#">EC-372</a> |
| P0507            | 0507  | ISC SYSTEM                      | —           | 2      | ×      | B                        | <a href="#">EC-374</a> |
| P050A            | 050A  | COLD START CONTROL              | —           | 2      | ×      | A                        | <a href="#">EC-376</a> |
| P050E            | 050E  | COLD START CONTROL              | —           | 2      | ×      | A                        | <a href="#">EC-376</a> |
| P0524            | 0524  | ENGINE OIL PRESSURE             | —           | 2      | ×      | B                        | <a href="#">EC-378</a> |
| P0550            | 0550  | PW ST P SEN/CIRC                | —           | 2      | —      | —                        | <a href="#">EC-381</a> |
| P0603            | 0603  | ECM BACK UP/CIRCUIT             | —           | 2      | ×      | B                        | <a href="#">EC-383</a> |
| P0605            | 0605  | ECM                             | —           | 1 or 2 | × or — | B                        | <a href="#">EC-385</a> |
| P0607            | 0607  | ECM                             | —           | 1      | ×      | B                        | <a href="#">EC-387</a> |
| P0643            | 0643  | SENSOR POWER/CIRC               | —           | 1      | ×      | B                        | <a href="#">EC-388</a> |
| P0705            | 0705  | T/M RANGE SENSOR A              | —           | 2      | ×      | B                        | <a href="#">TM-102</a> |
| P0710            | 0710  | FLUID TEMP SENSOR A             | —           | 2      | ×      | B                        | <a href="#">TM-103</a> |
| P0717            | 0717  | INPUT SPEED SENSOR A            | —           | 2      | ×      | B                        | <a href="#">TM-105</a> |
| P0720            | 0720  | OUTPUT SPEED SENSOR*6           | —           | 2      | ×      | B                        | <a href="#">TM-106</a> |
| P0729            | 0729  | 6GR INCORRECT RATIO             | —           | 2      | ×      | B                        | <a href="#">TM-110</a> |
| P0730            | 0730  | INCORRECT GR RATIO              | —           | 2      | ×      | B                        | <a href="#">TM-112</a> |
| P0731            | 0731  | 1GR INCORRECT RATIO             | —           | 2      | ×      | B                        | <a href="#">TM-114</a> |
| P0732            | 0732  | 2GR INCORRECT RATIO             | —           | 2      | ×      | B                        | <a href="#">TM-116</a> |
| P0733            | 0733  | 3GR INCORRECT RATIO             | —           | 2      | ×      | B                        | <a href="#">TM-118</a> |
| P0734            | 0734  | 4GR INCORRECT RATIO             | —           | 2      | ×      | B                        | <a href="#">TM-120</a> |
| P0735            | 0735  | 5GR INCORRECT RATIO             | —           | 2      | ×      | B                        | <a href="#">TM-122</a> |
| P0740            | 0740  | TORQUE CONVERTER                | —           | 2      | ×      | B                        | <a href="#">TM-124</a> |
| P0744            | 0744  | TORQUE CONVERTER                | —           | 2      | ×      | B                        | <a href="#">TM-125</a> |
| P0745            | 0745  | PC SOLENOID A                   | —           | 2      | ×      | B                        | <a href="#">TM-127</a> |
| P0750            | 0750  | SHIFT SOLENOID A                | —           | 2      | ×      | B                        | <a href="#">TM-128</a> |
| P0775            | 0775  | PC SOLENOID B                   | —           | 2      | ×      | B                        | <a href="#">TM-129</a> |
| P0780            | 0780  | SHIFT                           | —           | 1      | ×      | B                        | <a href="#">TM-130</a> |
| P0795            | 0795  | PC SOLENOID C                   | —           | 2      | ×      | B                        | <a href="#">TM-132</a> |
| P0850            | 0850  | P-N POS SW/CIRCUIT              | —           | 2      | ×      | B                        | <a href="#">EC-391</a> |
| P100A            | 100A  | VVEL SYSTEM-B1                  | —           | 2      | ×      | B                        | <a href="#">EC-394</a> |
| P100B            | 100B  | VVEL SYSTEM-B2                  | —           | 2      | ×      | B                        | <a href="#">EC-394</a> |
| P1087            | 1087  | VVEL SYSTEM-B1                  | —           | 1      | ×      | B                        | <a href="#">EC-398</a> |
| P1088            | 1088  | VVEL SYSTEM-B2                  | —           | 1      | ×      | B                        | <a href="#">EC-398</a> |
| P1089            | 1089  | VVEL POS SEN/CIRC-B1            | —           | 1      | ×      | B                        | <a href="#">EC-399</a> |
| P1090            | 1090  | VVEL ACTR MOT-B1                | —           | 1      | ×      | B                        | <a href="#">EC-402</a> |
| P1091            | 1091  | VVEL ACTR MOT PWR               | —           | 1 or 2 | ×      | B                        | <a href="#">EC-406</a> |
| P1092            | 1092  | VVEL POS SEN/CIRC-B2            | —           | 1      | ×      | B                        | <a href="#">EC-399</a> |



# ECM

< ECU DIAGNOSIS INFORMATION >

[VQ37VHR FOR USA AND CANADA]

| DTC*1            |       | Items<br>(CONSULT screen terms) | SRT<br>code | Trip   | MIL    | Permanent<br>DTC group*4 | Reference<br>page   |    |
|------------------|-------|---------------------------------|-------------|--------|--------|--------------------------|---|----|
| CONSULT<br>GST*2 | ECM*3 |                                 |             |        |        |                          |   |    |
| P1093            | 1093  | VVEL ACTR MOT-B2                | —           | 1      | ×      | B                        | <a href="#">EC-402</a>  | EC |
| P1148            | 1148  | CLOSED LOOP-B1                  | —           | 1      | ×      | A                        | <a href="#">EC-409</a>  |    |
| P1168            | 1168  | CLOSED LOOP-B2                  | —           | 1      | ×      | A                        | <a href="#">EC-409</a>  | C  |
| P1211            | 1211  | TCS C/U FUNCTN                  | —           | 2      | —      | —                        | <a href="#">EC-410</a>  |    |
| P1212            | 1212  | TCS/CIRC                        | —           | 2      | —      | —                        | <a href="#">EC-411</a>  | D  |
| P1217            | 1217  | ENG OVER TEMP                   | —           | 1      | ×      | B                        | <a href="#">EC-412</a>  |    |
| P1225            | 1225  | CTP LEARNING-B1                 | —           | 2      | —      | —                        | <a href="#">EC-416</a>  | E  |
| P1226            | 1226  | CTP LEARNING-B1                 | —           | 2      | —      | —                        | <a href="#">EC-418</a>  |    |
| P1233            | 1233  | ETC FNCTN/CIRC-B2               | —           | 1      | ×      | B                        | <a href="#">EC-420</a>  | F  |
| P1234            | 1234  | CTP LEARNING-B2                 | —           | 2      | —      | —                        | <a href="#">EC-416</a>  |    |
| P1235            | 1235  | CTP LEARNING-B2                 | —           | 2      | —      | —                        | <a href="#">EC-418</a>  | G  |
| P1236            | 1236  | ETC MOT-B2                      | —           | 1      | ×      | B                        | <a href="#">EC-424</a>  |    |
| P1238            | 1238  | ETC ACTR-B2                     | —           | 1      | ×      | B                        | <a href="#">EC-427</a>  | H  |
| P1239            | 1239  | TP SENSOR-B2                    | —           | 1      | ×      | B                        | <a href="#">EC-429</a>  |    |
| P1290            | 1290  | ETC MOT PWR-B2                  | —           | 1      | ×      | B                        | <a href="#">EC-432</a>  | I  |
| P1550            | 1550  | BAT CURRENT SENSOR              | —           | 2      | —      | —                        | <a href="#">EC-434</a>  |    |
| P1551            | 1551  | BAT CURRENT SENSOR              | —           | 2      | —      | —                        | <a href="#">EC-438</a>  | J  |
| P1552            | 1552  | BAT CURRENT SENSOR              | —           | 2      | —      | —                        | <a href="#">EC-438</a>  |    |
| P1553            | 1553  | BAT CURRENT SENSOR              | —           | 2      | —      | —                        | <a href="#">EC-442</a>  | K  |
| P1554            | 1554  | BAT CURRENT SENSOR              | —           | 2      | —      | —                        | <a href="#">EC-446</a>  |    |
| P1556            | 1556  | BAT TMP SEN/CIRC                | —           | 2      | —      | —                        | <a href="#">EC-450</a>  | L  |
| P1557            | 1557  | BAT TMP SEN/CIRC                | —           | 2      | —      | —                        | <a href="#">EC-450</a>  |    |
| P1564            | 1564  | ASCD SW                         | —           | 1      | —      | —                        | <a href="#">EC-453</a><br>(with ASCD)<br><a href="#">EC-456</a><br>(with ICC) | M  |
| P1568            | 1568  | ICC COMMAND VALUE               | —           | 1      | —      | —                        | <a href="#">EC-460</a>  |    |
| P1572            | 1572  | ASCD BRAKE SW                   | —           | 1      | —      | —                        | <a href="#">EC-461</a><br>(with ASCD)<br><a href="#">EC-467</a><br>(with ICC) | N  |
| P1574            | 1574  | ASCD VHL SPD SEN                | —           | 1      | —      | —                        | <a href="#">EC-473</a><br>(with ASCD)<br><a href="#">EC-475</a><br>(with ICC) |    |
| P1606            | 1606  | VVEL CONTROL MODULE             | —           | 1 or 2 | × or — | B                        | <a href="#">EC-477</a>  | O  |
| P1607            | 1607  | VVEL CONTROL MODULE             | —           | 1      | ×      | B                        | <a href="#">EC-478</a>  |    |
| P1608            | 1608  | VVEL SENSOR POWER/CIRC          | —           | 1      | ×      | B                        | <a href="#">EC-479</a>  | P  |
| P1610            | 1610  | LOCK MODE                       | —           | 2      | —      | —                        | <a href="#">SEC-41</a>  |    |
| P1611            | 1611  | ID DISCARD, IMM-ECM             | —           | 2      | —      | —                        | <a href="#">SEC-42</a>  | P  |
| P1612            | 1612  | CHAIN OF ECM-IMMU               | —           | 2      | —      | —                        | <a href="#">SEC-43</a>  |    |
| P1614            | 1614  | CHAIN OF IMMU-KEY               | —           | 2      | —      | —                        | <a href="#">SEC-44</a>  | P  |
| P1730            | 1730  | INTERLOCK                       | —           | 2      | ×      | B                        | <a href="#">TM-136</a>  |    |
| P1734            | 1734  | 7GR INCORRECT RATIO             | —           | 2      | ×      | B                        | <a href="#">TM-138</a>  | P  |
| P1805            | 1805  | BRAKE SW/CIRCUIT                | —           | 2      | —      | —                        | <a href="#">EC-482</a>  |    |

# ECM

< ECU DIAGNOSIS INFORMATION >

[VQ37VHR FOR USA AND CANADA]

| DTC*1            |       | Items<br>(CONSULT screen terms) | SRT<br>code | Trip | MIL | Permanent<br>DTC group*4 | Reference<br>page       |
|------------------|-------|---------------------------------|-------------|------|-----|--------------------------|-------------------------|
| CONSULT<br>GST*2 | ECM*3 |                                 |             |      |     |                          |                         |
| P1806            | 1806  | BRAKE VACUUM SEN                | —           | 2    | ×   | B                        | <a href="#">BRC-113</a> |
| P2100            | 2100  | ETC MOT PWR-B1                  | —           | 1    | ×   | B                        | <a href="#">EC-432</a>  |
| P2101            | 2101  | ETC FNCTN/CIRC-B1               | —           | 1    | ×   | B                        | <a href="#">EC-420</a>  |
| P2103            | 2103  | ETC MOT PWR                     | —           | 1    | ×   | B                        | <a href="#">EC-432</a>  |
| P2118            | 2118  | ETC MOT-B1                      | —           | 1    | ×   | B                        | <a href="#">EC-424</a>  |
| P2119            | 2119  | ETC ACTR-B1                     | —           | 1    | ×   | B                        | <a href="#">EC-427</a>  |
| P2122            | 2122  | APP SEN 1/CIRC                  | —           | 1    | ×   | B                        | <a href="#">EC-485</a>  |
| P2123            | 2123  | APP SEN 1/CIRC                  | —           | 1    | ×   | B                        | <a href="#">EC-485</a>  |
| P2127            | 2127  | APP SEN 2/CIRC                  | —           | 1    | ×   | B                        | <a href="#">EC-489</a>  |
| P2128            | 2128  | APP SEN 2/CIRC                  | —           | 1    | ×   | B                        | <a href="#">EC-489</a>  |
| P2132            | 2132  | TP SEN 1/CIRC-B2                | —           | 1    | ×   | B                        | <a href="#">EC-300</a>  |
| P2133            | 2133  | TP SEN 1/CIRC-B2                | —           | 1    | ×   | B                        | <a href="#">EC-300</a>  |
| P2135            | 2135  | TP SENSOR-B1                    | —           | 1    | ×   | B                        | <a href="#">EC-429</a>  |
| P2138            | 2138  | APP SENSOR                      | —           | 1    | ×   | B                        | <a href="#">EC-494</a>  |
| P2713            | 2713  | PC SOLENOID D                   | —           | 2    | ×   | B                        | <a href="#">TM-146</a>  |
| P2722            | 2722  | PC SOLENOID E                   | —           | 2    | ×   | B                        | <a href="#">TM-147</a>  |
| P2731            | 2731  | PC SOLENOID F                   | —           | 2    | ×   | B                        | <a href="#">TM-148</a>  |
| P2807            | 2807  | PC SOLENOID G                   | —           | 2    | ×   | B                        | <a href="#">TM-149</a>  |
| P2A00            | 2A00  | A/F SENSOR1 (B1)                | —           | 2    | ×   | A                        | <a href="#">EC-499</a>  |
| P2A03            | 2A03  | A/F SENSOR1 (B2)                | —           | 2    | ×   | A                        | <a href="#">EC-499</a>  |

\*1: 1st trip DTC No. is the same as DTC No.

\*2: This number is prescribed by SAE J2012/ISO 15031-6.

\*3: In Diagnostic Test Mode II (Self-diagnostic results), this number is controlled by NISSAN.

\*4: Refer to [EC-77, "Diagnosis Description"](#), "PERMANENT DIAGNOSTIC TROUBLE CODE (PERMANENT DTC)".

\*5: The troubleshooting for this DTC needs CONSULT.

\*6: When the fail-safe operations for both self-diagnoses occur, the MIL illuminates.

\*7: SRT code will not be set if the self-diagnostic result is NG.

\*8: When the ECM is in the mode that displays SRT status, MIL may blink. For the details, refer to "How to Display SRT Status".

## Test Value and Test Limit

INFOID:000000006882820

The following is the information specified in Service \$06 of SAE J1979/ISO 15031-5.

The test value is a parameter used to determine whether a system/circuit diagnostic test is OK or NG while being monitored by the ECM during self-diagnosis. The test limit is a reference value which is specified as the maximum or minimum value and is compared with the test value being monitored.

These data (test value and test limit) are specified by On Board Monitor ID (OBDMID), Test ID (TID), Unit and Scaling ID and can be displayed on the GST screen.

The items of the test value and test limit will be displayed with GST screen which items are provided by the ECM. (e.g., if bank 2 is not applied on this vehicle, only the items of bank 1 are displayed)

# ECM

< ECU DIAGNOSIS INFORMATION >

[VQ37VHR FOR USA AND CANADA]

| Item | OBD-MID | Self-diagnostic test item              | DTC   | Test value and Test limit (GST display) |                     | Description   |
|------|---------|--|-------|---|---------------------|---|
|      |         |  |       | TID                                     | Unit and Scaling ID |   |
| HO2S | 01H     | Air fuel ratio (A/F) sensor 1 (Bank 1) | P0131 | 83H                                     | 0BH                 | Minimum sensor output voltage for test cycle              |
|      |         |  | P0131 | 84H                                     | 0BH                 | Maximum sensor output voltage for test cycle              |
|      |         |  | P0130 | 85H                                     | 0BH                 | Minimum sensor output voltage for test cycle              |
|      |         |  | P0130 | 86H                                     | 0BH                 | Maximum sensor output voltage for test cycle              |
|      |         |  | P0133 | 87H                                     | 04H                 | Response rate: Response ratio (lean to rich)              |
|      |         |  | P0133 | 88H                                     | 04H                 | Response rate: Response ratio (rich to lean)              |
|      |         |  | P2A00 | 89H                                     | 84H                 | The amount of shift in air fuel ratio                     |
|      |         |  | P2A00 | 8AH                                     | 84H                 | The amount of shift in air fuel ratio                     |
|      |         |  | P0130 | 8BH                                     | 0BH                 | Difference in sensor output voltage                       |
|      |         |  | P0133 | 8CH                                     | 83H                 | Response gain at the limited frequency                    |
|      |         |  | P014C | 8DH                                     | 04H                 | O2 sensor slow response - Rich to lean bank 1 sensor 1    |
|      |         |  | P014C | 8EH                                     | 04H                 | O2 sensor slow response - Rich to lean bank 1 sensor 1    |
|      |         |  | P014D | 8FH                                     | 84H                 | O2 sensor slow response - Lean to rich bank 1 sensor 1    |
|      |         |  | P014D | 90H                                     | 84H                 | O2 sensor slow response - Lean to rich bank 1 sensor 1    |
|      |         |  | P015A | 91H                                     | 01H                 | O2 sensor delayed response - Rich to lean bank 1 sensor 1 |
|      |         |  | P015A | 92H                                     | 01H                 | O2 sensor delayed response - Rich to lean bank 1 sensor 1 |
|      |         |  | P015B | 93H                                     | 01H                 | O2 sensor delayed response - Lean to rich bank 1 sensor 1 |
|      |         |  | P015B | 94H                                     | 01H                 | O2 sensor delayed response - Lean to rich bank 1 sensor 1 |
|      | 02H     | Heated oxygen sensor 2 (Bank 1)        | P0138 | 07H                                     | 0CH                 | Minimum sensor output voltage for test cycle              |
|      |         |  | P0137 | 08H                                     | 0CH                 | Maximum sensor output voltage for test cycle              |
|      |         |  | P0138 | 80H                                     | 0CH                 | Sensor output voltage                                     |
|      |         |  | P0139 | 81H                                     | 0CH                 | Difference in sensor output voltage                       |
|      |         |  | P0139 | 82H                                     | 11H                 | Rear O2 sensor delay response diagnosis                   |
|      | 03H     | Heated oxygen sensor 3 (Bank 1)        | P0143 | 07H                                     | 0CH                 | Minimum sensor output voltage for test cycle              |
|      |         |  | P0144 | 08H                                     | 0CH                 | Maximum sensor output voltage for test cycle              |
|      |         |  | P0146 | 80H                                     | 0CH                 | Sensor output voltage                                     |
|      |         |  | P0145 | 81H                                     | 0CH                 | Difference in sensor output voltage                       |

A  
EC  
C  
D  
E  
F  
G  
H  
I  
J  
K  
L  
M  
N  
O  
P

# ECM

< ECU DIAGNOSIS INFORMATION >

[VQ37VHR FOR USA AND CANADA]

| Item | OBD-MID | Self-diagnostic test item              | DTC   | Test value and Test limit (GST display)                   |                     | Description   |
|------|---------|--|-------|---|---------------------|---|
|      |         |  |       | TID   | Unit and Scaling ID |   |
| HO2S | 05H     | Air fuel ratio (A/F) sensor 1 (Bank 2) | P0151 | 83H   | 0BH                 | Minimum sensor output voltage for test cycle              |
|      |         |  | P0151 | 84H   | 0BH                 | Maximum sensor output voltage for test cycle              |
|      |         |  | P0150 | 85H   | 0BH                 | Minimum sensor output voltage for test cycle              |
|      |         |  | P0150 | 86H   | 0BH                 | Maximum sensor output voltage for test cycle              |
|      |         |  | P0153 | 87H   | 04H                 | Response rate: Response ratio (lean to rich)              |
|      |         |  | P0153 | 88H   | 04H                 | Response rate: Response ratio (rich to lean)              |
|      |         |  | P2A03 | 89H   | 84H                 | The amount of shift in air fuel ratio                     |
|      |         |  | P2A03 | 8AH   | 84H                 | The amount of shift in air fuel ratio                     |
|      |         |  | P0150 | 8BH   | 0BH                 | Difference in sensor output voltage                       |
|      |         |  | P0153 | 8CH   | 83H                 | Response gain at the limited frequency                    |
|      |         |  | P014E | 8DH   | 04H                 | O2 sensor slow response - Rich to lean bank 2 sensor 1    |
|      |         |  | P014E | 8EH   | 04H                 | O2 sensor slow response - Rich to lean bank 2 sensor 1    |
|      |         |  | P014F | 8FH   | 84H                 | O2 sensor slow response - Lean to rich bank 2 sensor 1    |
|      |         |  | P014F | 90H   | 84H                 | O2 sensor slow response - Lean to rich bank 2 sensor 1    |
|      |         |  | P015C | 91H   | 01H                 | O2 sensor delayed response - Rich to lean bank 2 sensor 1 |
|      |         |  | P015C | 92H   | 01H                 | O2 sensor delayed response - Rich to lean bank 2 sensor 1 |
|      | P015D   | 93H                                    | 01H   | O2 sensor delayed response - Lean to rich bank 2 sensor 1 |                     |   |
|      | P015D   | 94H                                    | 01H   | O2 sensor delayed response - Lean to rich bank 2 sensor 1 |                     |   |
|      | 06H     | Heated oxygen sensor 2 (Bank 2)        | P0158 | 07H   | 0CH                 | Minimum sensor output voltage for test cycle              |
|      |         |  | P0157 | 08H   | 0CH                 | Maximum sensor output voltage for test cycle              |
|      |         |  | P0158 | 80H   | 0CH                 | Sensor output voltage                                     |
|      |         |  | P0159 | 81H   | 0CH                 | Difference in sensor output voltage                       |
|      |         |  | P0159 | 82H   | 11H                 | Rear O2 sensor delay response diagnosis                   |
|      | 07H     | Heated oxygen sensor 3 (Bank2)         | P0163 | 07H   | 0CH                 | Minimum sensor output voltage for test cycle              |
|      |         |  | P0164 | 08H   | 0CH                 | Maximum sensor output voltage for test cycle              |
|      |         |  | P0166 | 80H   | 0CH                 | Sensor output voltage                                     |
|      |         |  | P0165 | 81H   | 0CH                 | Difference in sensor output voltage                       |

# ECM

< ECU DIAGNOSIS INFORMATION >

[VQ37VHR FOR USA AND CANADA]

| Item          | OBD-MID | Self-diagnostic test item           | DTC   | Test value and Test limit (GST display) |                     | Description  |
|---------------|---------|-------------------------------------|-------|---|---------------------|--|
|               |         |                                     |       | TID                                     | Unit and Scaling ID |  |
| CATA-<br>LYST | 21H     | Three way catalyst function (Bank1) | P0420 | 80H                                     | 01H                 | O2 storage index   |
|               |         |                                     | P0420 | 82H                                     | 01H                 | Switching time lag engine exhaust index value  |
|               |         |                                     | P2423 | 83H                                     | 0CH                 | Difference in 3rd O2 sensor output voltage   |
|               |         |                                     | P2423 | 84H                                     | 84H                 | O2 storage index in HC trap catalyst   |
|               | 22H     | Three way catalyst function (Bank2) | P0430 | 80H                                     | 01H                 | O2 storage index   |
|               |         |                                     | P0430 | 82H                                     | 01H                 | Switching time lag engine exhaust index value  |
|               |         |                                     | P2424 | 83H                                     | 0CH                 | Difference in 3rd O2 sensor output voltage   |
|               |         |                                     | P2424 | 84H                                     | 84H                 | O2 storage index in HC trap catalyst   |
| EGR<br>SYSTEM | 31H     | EGR function                        | P0400 | 80H                                     | 96H                 | Low flow faults: EGR temp change rate (short term)                                   |
|               |         |                                     | P0400 | 81H                                     | 96H                 | Low flow faults: EGR temp change rate (long term)                                    |
|               |         |                                     | P0400 | 82H                                     | 96H                 | Low flow faults: Difference between max EGR temp and EGR temp under idling condition |
|               |         |                                     | P0400 | 83H                                     | 96H                 | Low flow faults: Max EGR temp  |
|               |         |                                     | P1402 | 84H                                     | 96H                 | High Flow Faults: EGR temp increase rate   |
| VVT<br>SYSTEM | 35H     | VVT Monitor (Bank1)                 | P0011 | 80H                                     | 9DH                 | VTC intake function diagnosis (VTC alignment check diagnosis)                        |
|               |         |                                     | P0014 | 81H                                     | 9DH                 | VTC exhaust function diagnosis (VTC alignment check diagnosis)                       |
|               |         |                                     | P0011 | 82H                                     | 9DH                 | VTC intake function diagnosis (VTC drive failure diagnosis)                          |
|               |         |                                     | P0014 | 83H                                     | 9DH                 | VTC exhaust function diagnosis (VTC drive failure diagnosis)                         |
|               |         |                                     | P100A | 84H                                     | 10H                 | VEL slow response diagnosis  |
|               |         |                                     | P1090 | 85H                                     | 10H                 | VEL servo system diagnosis   |
|               | 36H     | VVT Monitor (Bank2)                 | P0021 | 80H                                     | 9DH                 | VTC intake function diagnosis (VTC alignment check diagnosis)                        |
|               |         |                                     | P0024 | 81H                                     | 9DH                 | VTC exhaust function diagnosis (VTC alignment check diagnosis)                       |
|               |         |                                     | P0021 | 82H                                     | 9DH                 | VTC intake function diagnosis (VTC drive failure diagnosis)                          |
|               |         |                                     | P0024 | 83H                                     | 9DH                 | VTC exhaust function diagnosis (VTC drive failure diagnosis)                         |
|               |         |                                     | P100B | 84H                                     | 10H                 | VEL slow response diagnosis  |
|               |         |                                     | P1093 | 85H                                     | 10H                 | VEL servo system diagnosis   |

A

EC

C

D

E

F

G

H

I

J

K

L

M

N

O

P

# ECM

< ECU DIAGNOSIS INFORMATION >

[VQ37VHR FOR USA AND CANADA]

| Item             | OBD-MID | Self-diagnostic test item                  | DTC                                   | Test value and Test limit (GST display) |                     | Description  |
|------------------|---------|--|---------------------------------------|---|---------------------|--|
|                  |         |  |                                       | TID                                     | Unit and Scaling ID |  |
| EVAP SYSTEM      | 39H     | EVAP control system leak (Cap Off)         | P0455                                 | 80H                                     | 0CH                 | Difference in pressure sensor output voltage before and after pull down                |
|                  | 3BH     | EVAP control system leak (Small leak)      | P0442                                 | 80H                                     | 05H                 | Leak area index (for more than 0.04 inch)  |
|                  | 3CH     | EVAP control system leak (Very small leak) | P0456                                 | 80H                                     | 05H                 | Leak area index (for more than 0.02 inch)  |
|                  |         |  | P0456                                 | 81H                                     | FDH                 | Maximum internal pressure of EVAP system during monitoring                             |
|                  |         |  | P0456                                 | 82H                                     | FDH                 | Internal pressure of EVAP system at the end of monitoring                              |
|                  | 3DH     | Purge flow system                          | P0441                                 | 83H                                     | 0CH                 | Difference in pressure sensor output voltage before and after vent control valve close |
| O2 SENSOR HEATER | 41H     | A/F sensor 1 heater (Bank 1)               | Low Input: P0031<br>High Input: P0032 | 81H                                     | 0BH                 | Converted value of heater electric current to voltage                                  |
|                  | 42H     | Heated oxygen sensor 2 heater (Bank 1)     | Low Input: P0037<br>High Input: P0038 | 80H                                     | 0CH                 | Converted value of heater electric current to voltage                                  |
|                  | 43H     | Heated oxygen sensor 3 heater (Bank 1)     | P0043                                 | 80H                                     | 0CH                 | Converted value of heater electric current to voltage                                  |
|                  | 45H     | A/F sensor 1 heater (Bank 2)               | Low Input: P0051<br>High Input: P0052 | 81H                                     | 0BH                 | Converted value of heater electric current to voltage                                  |
|                  | 46H     | Heated oxygen sensor 2 heater (Bank 2)     | Low Input: P0057<br>High Input: P0058 | 80H                                     | 0CH                 | Converted value of heater electric current to voltage                                  |
|                  | 47H     | Heated oxygen sensor 3 heater (Bank 2)     | P0063                                 | 80H                                     | 0CH                 | Converted value of heater electric current to voltage                                  |
| SECONDARY AIR    | 71H     | Secondary air system                       | P0411                                 | 80H                                     | 01H                 | Secondary air injection system incorrect flow detected                                 |
|                  |         |  | Bank1: P0491<br>Bank2: P0492          | 81H                                     | 01H                 | Secondary air injection system insufficient flow                                       |
|                  |         |  | P2445                                 | 82H                                     | 01H                 | Secondary air injection system pump stuck off  |
|                  |         |  | P2448                                 | 83H                                     | 01H                 | Secondary air injection system high airflow  |
|                  |         |  | Bank1: P2440<br>Bank2: P2442          | 84H                                     | 01H                 | Secondary air injection system switching valve stuck open                              |
|                  |         |  | P2440                                 | 85H                                     | 01H                 | Secondary air injection system switching valve stuck open                              |
|                  |         |  | P2444                                 | 86H                                     | 01H                 | Secondary air injection system pump stuck on   |
| FUEL SYSTEM      | 81H     | Fuel injection system function (Bank 1)    | P0171 or P0172                        | 80H                                     | 2FH                 | Long term fuel trim  |
|                  |         |  | P0171 or P0172                        | 81H                                     | 24H                 | The number of lambda control clamped   |
|                  |         |  | P117A                                 | 82H                                     | 03H                 | Cylinder A/F imbalance monitoring  |
|                  | 82H     | Fuel injection system function (Bank 2)    | P0174 or P0175                        | 80H                                     | 2FH                 | Long term fuel trim  |
|                  |         |  | P0174 or P0175                        | 81H                                     | 24H                 | The number of lambda control clamped   |
|                  |         |  | P117B                                 | 82H                                     | 03H                 | Cylinder A/F imbalance monitoring  |

# ECM

< ECU DIAGNOSIS INFORMATION >

[VQ37VHR FOR USA AND CANADA]

| Item    | OBD-MID | Self-diagnostic test item  | DTC   | Test value and Test limit (GST display) |                     | Description  |
|---------|---------|----------------------------|-------|---|---------------------|--|
|         |         |                            |       | TID                                     | Unit and Scaling ID |  |
| MISFIRE | A1H     | Multiple cylinder misfires | P0301 | 80H                                     | 24H                 | Misfiring counter at 1000 revolution of the first cylinder     |
|         |         |                            | P0302 | 81H                                     | 24H                 | Misfiring counter at 1000 revolution of the second cylinder    |
|         |         |                            | P0303 | 82H                                     | 24H                 | Misfiring counter at 1000 revolution of the third cylinder     |
|         |         |                            | P0304 | 83H                                     | 24H                 | Misfiring counter at 1000 revolution of the fourth cylinder    |
|         |         |                            | P0305 | 84H                                     | 24H                 | Misfiring counter at 1000 revolution of the fifth cylinder     |
|         |         |                            | P0306 | 85H                                     | 24H                 | Misfiring counter at 1000 revolution of the sixth cylinder     |
|         |         |                            | P0307 | 86H                                     | 24H                 | Misfiring counter at 1000 revolution of the seventh cylinder   |
|         |         |                            | P0308 | 87H                                     | 24H                 | Misfiring counter at 1000 revolution of the eighth cylinder    |
|         |         |                            | P0300 | 88H                                     | 24H                 | Misfiring counter at 1000 revolution of the multiple cylinders |
|         |         |                            | P0301 | 89H                                     | 24H                 | Misfiring counter at 200 revolution of the first cylinder      |
|         |         |                            | P0302 | 8AH                                     | 24H                 | Misfiring counter at 200 revolution of the second cylinder     |
|         |         |                            | P0303 | 8BH                                     | 24H                 | Misfiring counter at 200 revolution of the third cylinder      |
|         |         |                            | P0304 | 8CH                                     | 24H                 | Misfiring counter at 200 revolution of the fourth cylinder     |
|         |         |                            | P0305 | 8DH                                     | 24H                 | Misfiring counter at 200 revolution of the fifth cylinder      |
|         |         |                            | P0306 | 8EH                                     | 24H                 | Misfiring counter at 200 revolution of the sixth cylinder      |
|         |         |                            | P0307 | 8FH                                     | 24H                 | Misfiring counter at 200 revolution of the seventh cylinder    |
|         |         |                            | P0308 | 90H                                     | 24H                 | Misfiring counter at 200 revolution of the eighth cylinder     |
|         |         |                            | P0300 | 91H                                     | 24H                 | Misfiring counter at 1000 revolution of the single cylinder    |
|         |         |                            | P0300 | 92H                                     | 24H                 | Misfiring counter at 200 revolution of the single cylinder     |
|         |         |                            | P0300 | 93H                                     | 24H                 | Misfiring counter at 200 revolution of the multiple cylinders  |

A  
EC  
C  
D  
E  
F  
G  
H  
I  
J  
K  
L  
M  
N  
O  
P

# ECM

< ECU DIAGNOSIS INFORMATION >

[VQ37VHR FOR USA AND CANADA]

| Item    | OBD-MID | Self-diagnostic test item | DTC   | Test value and Test limit (GST display) |                     | Description  |
|---------|---------|---------------------------|-------|---|---------------------|--|
|         |         |                           |       | TID                                     | Unit and Scaling ID |  |
| MISFIRE | A2H     | No. 1 cylinder misfire    | P0301 | 0BH                                     | 24H                 | EWMA (Exponential Weighted Moving Average) misfire counts for last 10 driving cycles |
|         |         |                           | P0301 | 0CH                                     | 24H                 | Misfire counts for last/current driving cycles                                       |
|         | A3H     | No. 2 cylinder misfire    | P0302 | 0BH                                     | 24H                 | EWMA (Exponential Weighted Moving Average) misfire counts for last 10 driving cycles |
|         |         |                           | P0302 | 0CH                                     | 24H                 | Misfire counts for last/current driving cycles                                       |
|         | A4H     | No. 3 cylinder misfire    | P0303 | 0BH                                     | 24H                 | EWMA (Exponential Weighted Moving Average) misfire counts for last 10 driving cycles |
|         |         |                           | P0303 | 0CH                                     | 24H                 | Misfire counts for last/current driving cycles                                       |
|         | A5H     | No. 4 cylinder misfire    | P0304 | 0BH                                     | 24H                 | EWMA (Exponential Weighted Moving Average) misfire counts for last 10 driving cycles |
|         |         |                           | P0304 | 0CH                                     | 24H                 | Misfire counts for last/current driving cycles                                       |
|         | A6H     | No. 5 cylinder misfire    | P0305 | 0BH                                     | 24H                 | EWMA (Exponential Weighted Moving Average) misfire counts for last 10 driving cycles |
|         |         |                           | P0305 | 0CH                                     | 24H                 | Misfire counts for last/current driving cycles                                       |
|         | A7H     | No. 6 cylinder misfire    | P0306 | 0BH                                     | 24H                 | EWMA (Exponential Weighted Moving Average) misfire counts for last 10 driving cycles |
|         |         |                           | P0306 | 0CH                                     | 24H                 | Misfire counts for last/current driving cycles                                       |
|         | A8H     | No. 7 cylinder misfire    | P0307 | 0BH                                     | 24H                 | EWMA (Exponential Weighted Moving Average) misfire counts for last 10 driving cycles |
|         |         |                           | P0307 | 0CH                                     | 24H                 | Misfire counts for last/current driving cycles                                       |
|         | A9H     | No. 8 cylinder misfire    | P0308 | 0BH                                     | 24H                 | EWMA (Exponential Weighted Moving Average) misfire counts for last 10 driving cycles |
|         |         |                           | P0308 | 0CH                                     | 24H                 | Misfire counts for last/current driving cycles                                       |



# VVEL CONTROL MODULE

< ECU DIAGNOSIS INFORMATION >

[VQ37VHR FOR USA AND CANADA]

## VVEL CONTROL MODULE

### Reference Value

INFOID:000000006882821

### TERMINAL LAYOUT

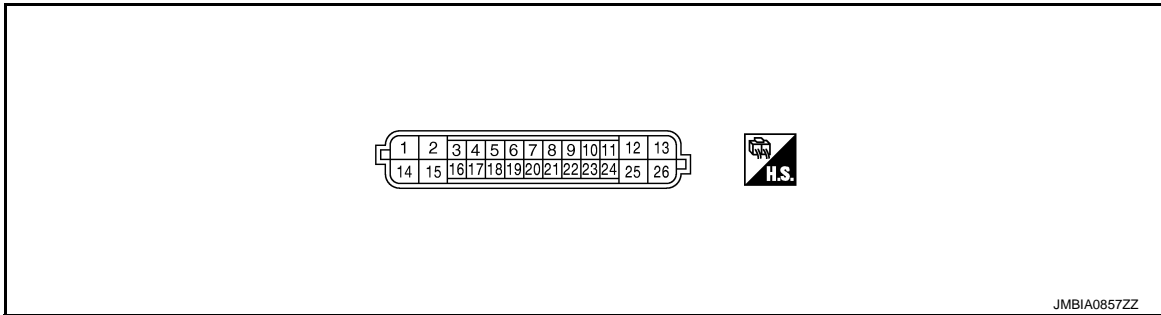

### PHYSICAL VALUES

#### NOTE:

- VVEL control module is located behind the IPDM E/R. For this inspection, remove hoodledge cover (RH).
- Specification data are reference values and are measured between each terminal and ground.
- Pulse signal is measured by CONSULT.

| Terminal No. |          | Description   |              | Condition  | Value (Approx.)             |
|--------------|----------|---|--------------|--|-----------------------------|
| +            | —        | Signal name   | Input/Output |  |                             |
| 1 (W)        | 14 (B/R) | VVEL actuator motor power supply (bank 2)                     | Input        | [Ignition switch: ON]  | BATTERY VOLTAGE (11 - 14 V) |
| 2 (L/B)      | 14 (B/R) | VVEL actuator motor (High lift) (bank 2)                      | Output       | [Engine is running] <ul style="list-style-type: none"> <li>• Warm-up condition</li> <li>• Idle speed</li> </ul>                                  | 0 - 14 V★<br>               |
|              |          |   |              | [Engine is running] <ul style="list-style-type: none"> <li>• Warm-up condition</li> <li>• When revving engine up to 2,000 rpm quickly</li> </ul> | 0 - 14 V★<br>               |
| 3 (B)        | 4 (W)    | VVEL control shaft position sensor 1 (bank 1)                 | Input        | [Engine is running] <ul style="list-style-type: none"> <li>• Warm-up condition</li> <li>• Idle speed</li> </ul>                                  | Approx.0.25 - 1.40 V        |
|              |          |   |              | [Engine is running] <ul style="list-style-type: none"> <li>• Warm-up condition</li> <li>• When revving engine up to 2,000 rpm quickly</li> </ul> | Approx.0.25 - 4.75 V        |
| 4 (W)        | —        | Sensor ground [VVEL control shaft position sensor 1 (bank 1)] | —            | —  | —                           |

# VVEL CONTROL MODULE

< ECU DIAGNOSIS INFORMATION >

[VQ37VHR FOR USA AND CANADA]

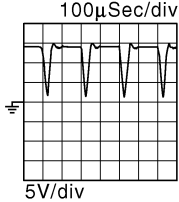
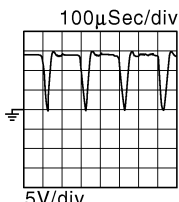
| Terminal No. |             | Description   |              | Condition   | Value (Approx.)  |
|--------------|-------------|---|--------------|---|--|
| +            | -           | Signal name   | Input/Output |   |  |
| 5<br>(W)     | 6<br>(B)    | VVEL control shaft position sensor 1 (bank 2)                       | Input        | [Engine is running]<br>• Warm-up condition<br>• Idle speed                                  | Approx.0.25 - 1.40 V   |
|              |             |   |              | [Engine is running]<br>• Warm-up condition<br>• When revving engine up to 2,000 rpm quickly | Approx.0.25 - 4.75 V   |
| 6<br>(B)     | —           | Sensor ground [VVEL control shaft position sensor 1 (bank 2)]       | —            | —   | —  |
| 7<br>(Y)     | 6<br>(B)    | Sensor power supply [VVEL control shaft position sensor 1 (bank 2)] | —            | [Ignition switch: ON]   | 5 V  |
| 8<br>(R)     | 14<br>(B/R) | Power supply for VVEL control module                                | —            | [Ignition switch: ON]   | BATTERY VOLTAGE (11 - 14 V)  |
| 9<br>(L)     | 4<br>(W)    | Sensor power supply [VVEL control shaft position sensor 1 (bank 1)] | —            | [Ignition switch: ON]   | 5 V  |
| 11<br>(GR)   | —           | CAN communication line [ECM]  | Input/Output | —   | —  |
| 12<br>(L/B)  | 14<br>(B/R) | VVEL actuator motor (High lift) (bank 1)                            | Output       | [Engine is running]<br>• Warm-up condition<br>• Idle speed                                  | 0 - 14 V★<br>  |
|              |             |   |              | [Engine is running]<br>• Warm-up condition<br>• When revving engine up to 2,000 rpm quickly | 0 - 14 V★<br> |
| 13<br>(W)    | 14<br>(B/R) | VVEL actuator motor power supply (bank 1)                           | Input        | [Ignition switch: ON]   | BATTERY VOLTAGE (11 - 14 V)  |
| 14<br>(B/R)  | —           | VVEL control module ground  | —            | [Engine is running]<br>• Idle speed   | —  |

# VVEL CONTROL MODULE

< ECU DIAGNOSIS INFORMATION >

[VQ37VHR FOR USA AND CANADA]

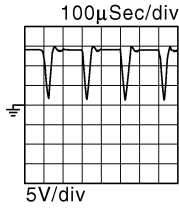
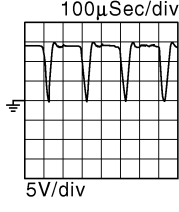
| Terminal No. |             | Description   |              | Condition   | Value (Approx.)  |
|--------------|-------------|---|--------------|---|--|
| +            | -           | Signal name   | Input/Output |   |  |
| 15<br>(L/W)  | 14<br>(B/R) | VVEL actuator motor (Low lift) (bank 2)                             | Output       | [Engine is running]<br>• Warm-up condition<br>• Idle speed                                  | 0 - 14 V★<br> |
|              |             |   |              | [Engine is running]<br>• Warm-up condition<br>• When revving engine up to 2,000 rpm quickly | 0 - 14 V★<br> |
| 16<br>(R)    | 17<br>(G)   | VVEL control shaft position sensor 2 (bank 1)                       | Input        | [Engine is running]<br>• Warm-up condition<br>• Idle speed                                  | 3.50 - 4.75 V  |
|              |             |   |              | [Engine is running]<br>• Warm-up condition<br>• When revving engine up to 2,000 rpm quickly | 0.25 - 4.75 V  |
| 17<br>(G)    | —           | Sensor ground [VVEL control shaft position sensor 2 (bank 1)]       | —            | —   | —  |
| 18<br>(G)    | 19<br>(R)   | VVEL control shaft position sensor 2 (bank 2)                       | Input        | [Engine is running]<br>• Warm-up condition<br>• Idle speed                                  | 3.50 - 4.75 V  |
|              |             |   |              | [Engine is running]<br>• Warm-up condition<br>• When revving engine up to 2,000 rpm quickly | 0.25 - 4.75 V  |
| 19<br>(R)    | —           | Sensor ground [VVEL control shaft position sensor 2 (bank 2)]       | —            | —   | —  |
| 20<br>(L)    | 19<br>(R)   | Sensor power supply [VVEL control shaft position sensor 2 (bank 2)] | —            | [Ignition switch: ON]   | 5 V  |
| 21<br>(V)    | 14<br>(B/R) | VVEL actuator motor relay abort signal                              | Input        | [Engine is running]<br>• Warm-up condition<br>• Idle speed                                  | 0 V  |
| 22<br>(Y)    | 17<br>(G)   | Sensor power supply [VVEL position sensor 2 (bank 1)]               | —            | [Ignition switch: ON]   | 5 V  |
| 23<br>(P)    | 14<br>(B/R) | VVEL control motor relay  | Output       | [Ignition switch: OFF]  | BATTERY VOLTAGE (11 - 14 V)  |
|              |             |   |              | [Ignition switch: ON]   | 0 - 1.0 V  |
| 24<br>(L)    | —           | CAN communication line  | Input/Output | —   | —  |

A

EC

C

D

E

F

G

H

I

J

K

L

M

N

O

P

# VVEL CONTROL MODULE

< ECU DIAGNOSIS INFORMATION >

[VQ37VHR FOR USA AND CANADA]

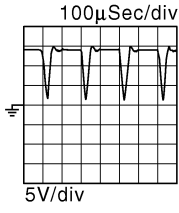
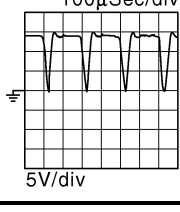
| Terminal No. |             | Description                            |              | Condition  | Value (Approx.)   |
|--------------|-------------|--|--------------|--|---|
| +            | -           | Signal name                            | Input/Output |  |   |
| 25<br>(L/W)  | 14<br>(B/R) | VVEL control motor (Low lift) (bank 1) | Output       | [Engine is running] <ul style="list-style-type: none"> <li>• Warm-up condition</li> <li>• Idle speed</li> </ul>                                  | 0 - 14 V★<br><br>5V/div <span style="float: right;">JMBIA0854ZZ</span> |
|              |             |  |              | [Engine is running] <ul style="list-style-type: none"> <li>• Warm-up condition</li> <li>• When revving engine up to 2,000 rpm quickly</li> </ul> | 0 - 14 V★<br><br>5V/div <span style="float: right;">JMBIA0855ZZ</span> |

★: Average voltage for pulse signal (Actual pulse signal can be confirmed by oscilloscope.)

# ENGINE CONTROL SYSTEM

[VQ37VHR FOR USA AND CANADA]

< WIRING DIAGRAM >

## WIRING DIAGRAM

### ENGINE CONTROL SYSTEM

#### Wiring Diagram

INFOID:000000006882822

A

EC

For connector terminal arrangements, harness layouts, and alphabets in a  (option abbreviation; if not described in wiring diagram), refer to [GI-12. "Connector Information"](#).

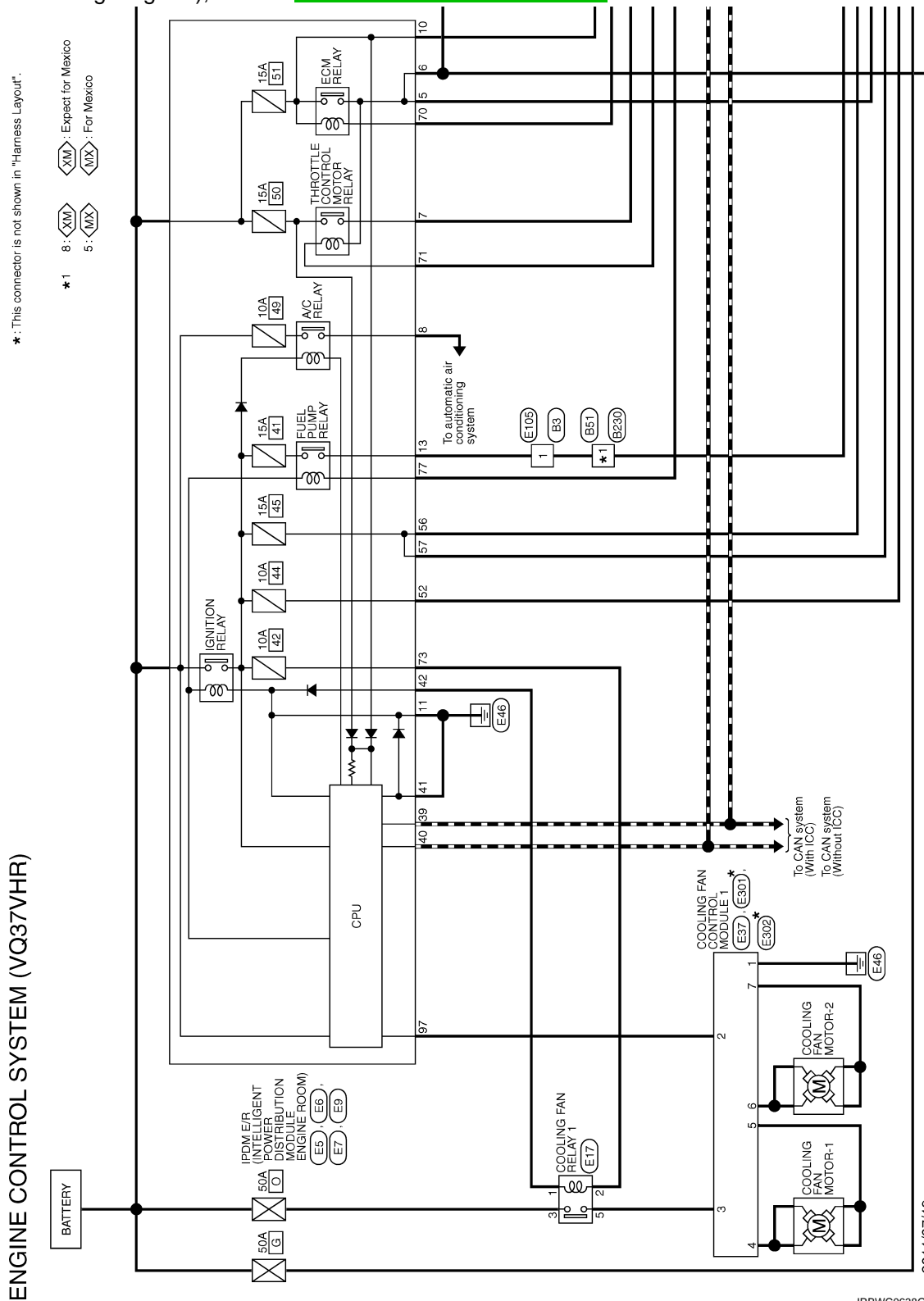

C

D

E

F

G

H

I

J

K

L

M

N

O

P

# ENGINE CONTROL SYSTEM

[VQ37VHR FOR USA AND CANADA]

< WIRING DIAGRAM >

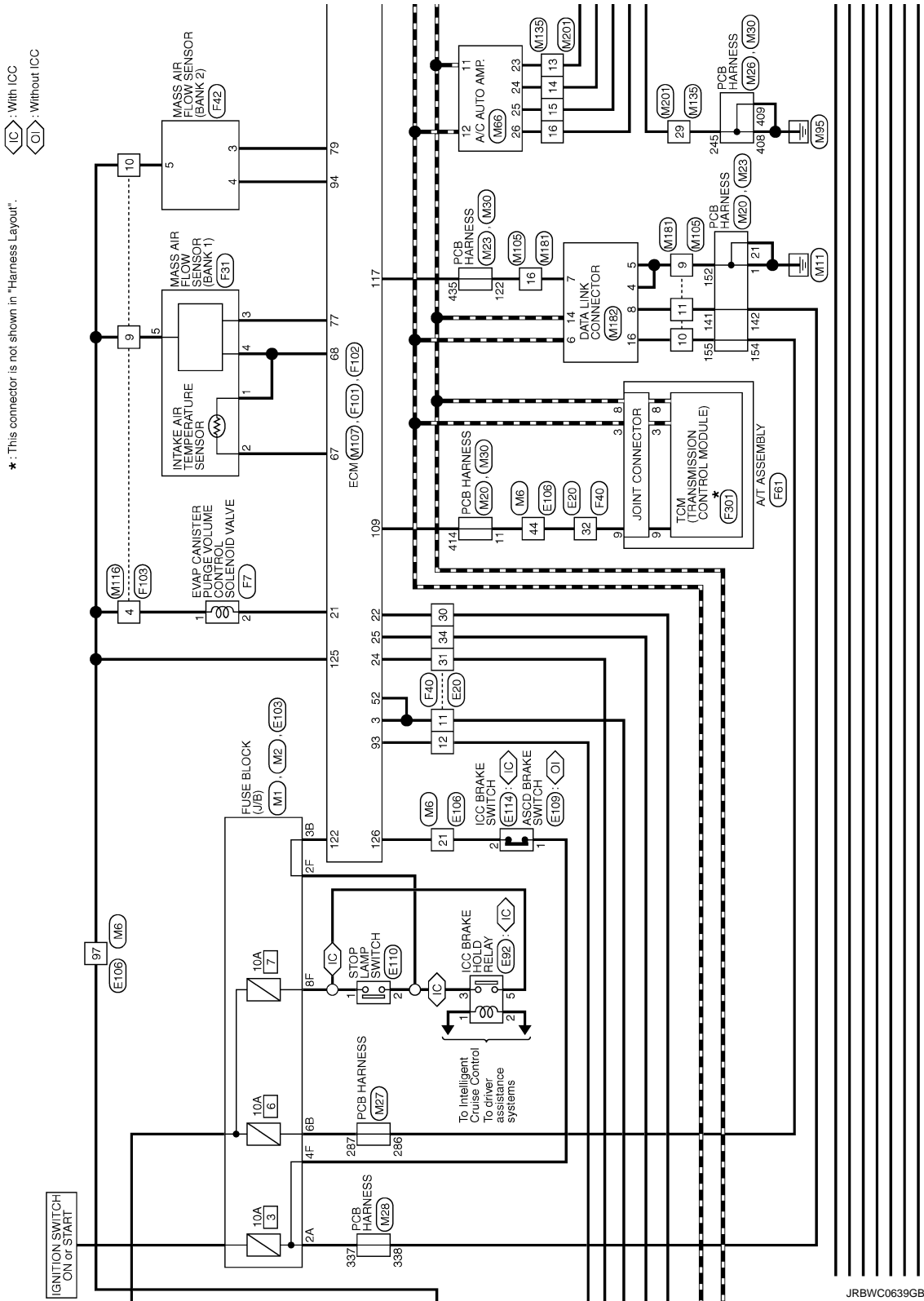

JRBWC0639GB

# ENGINE CONTROL SYSTEM

[VQ37VHR FOR USA AND CANADA]

< WIRING DIAGRAM >

\*: This connector is not shown in "Harness Layout".

XM: Expect for Mexico  
MX: For Mexico  
IC: With ICC  
OI: Without ICC

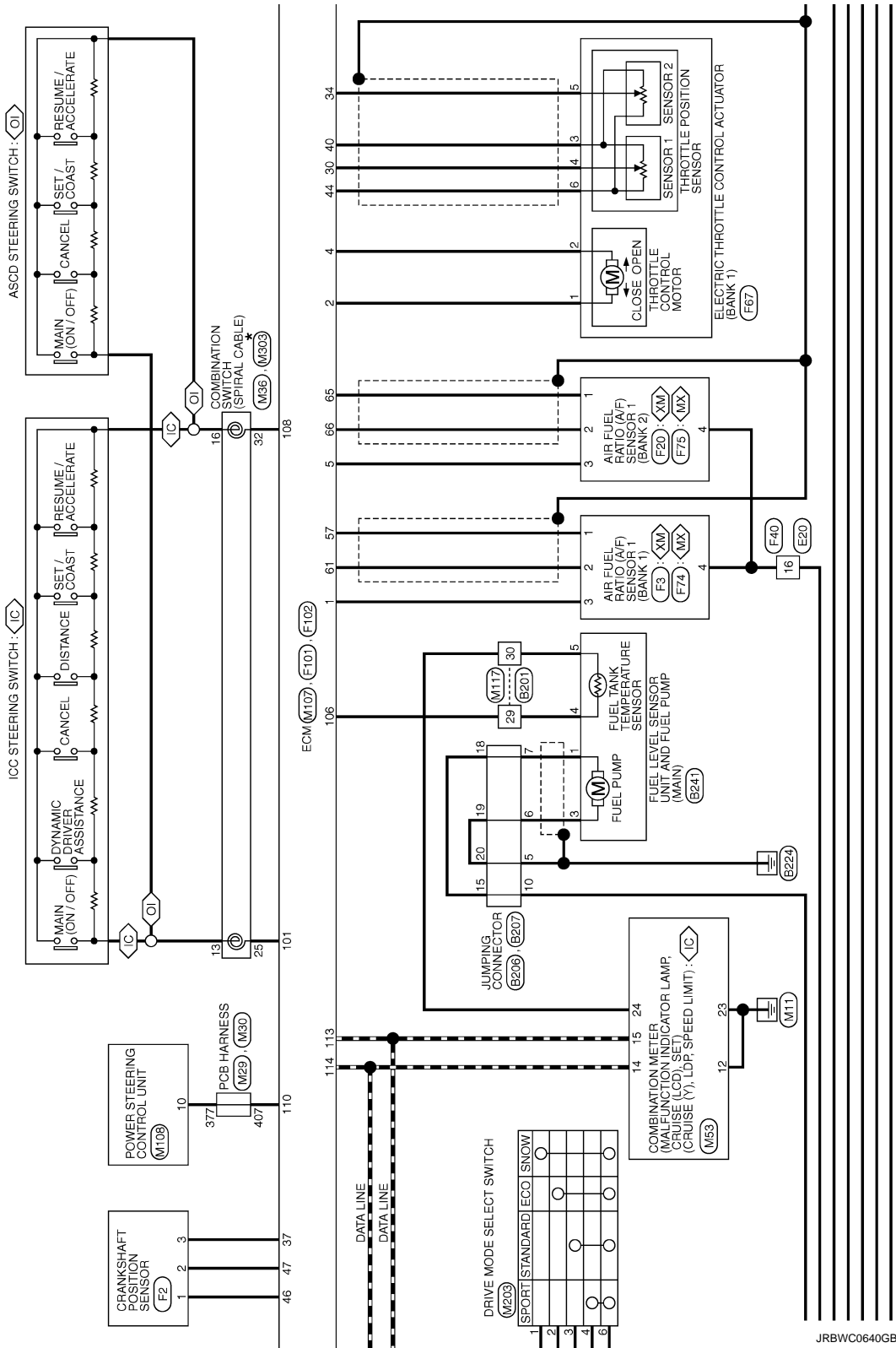

A  
**EC**  
 C  
 D  
 E  
 F  
 G  
 H  
 I  
 J  
 K  
 L  
 M  
 N  
 O  
 P

# ENGINE CONTROL SYSTEM

[VQ37VHR FOR USA AND CANADA]

< WIRING DIAGRAM >

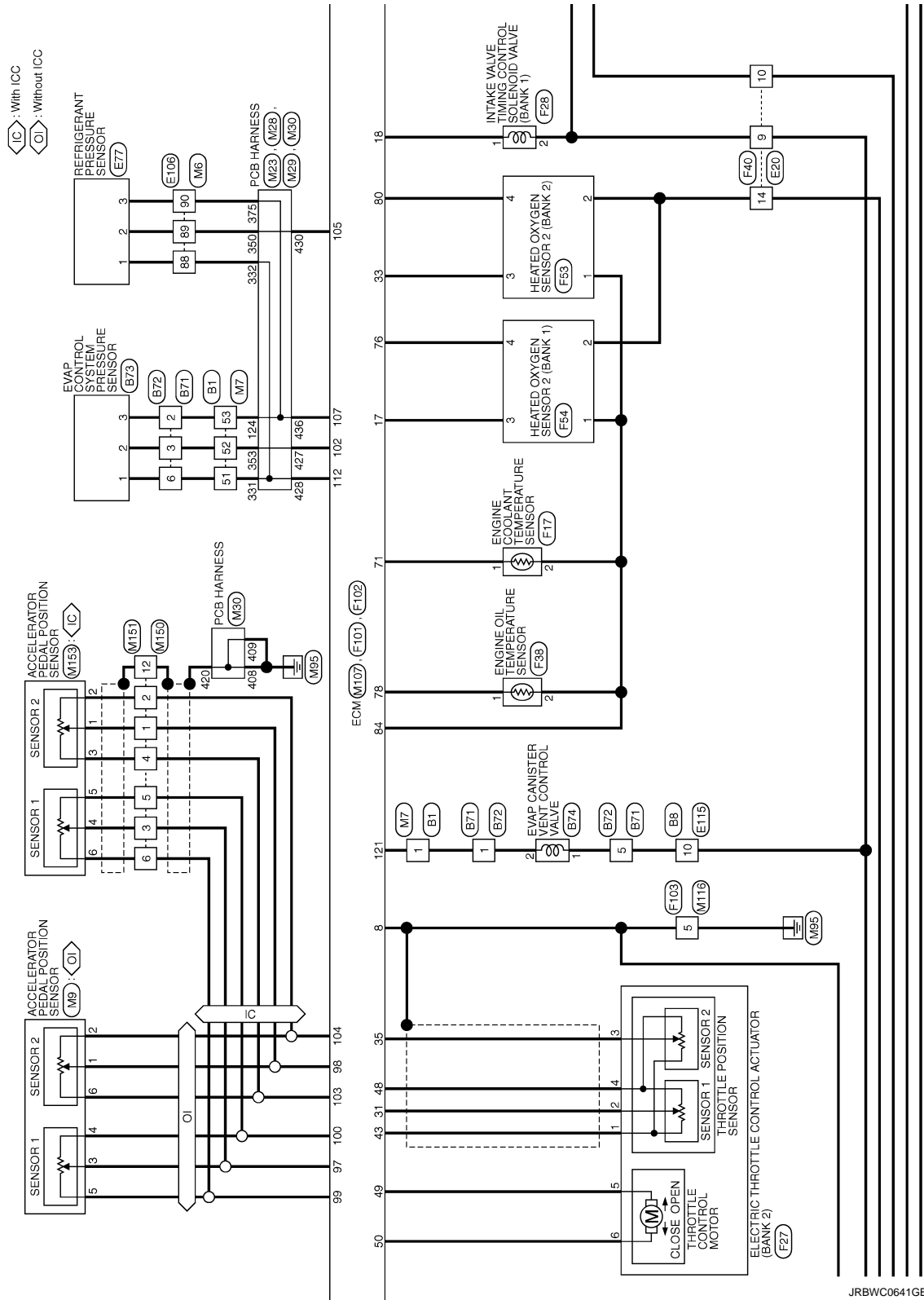

JRBWC0641GB



# ENGINE CONTROL SYSTEM

[VQ37VHR FOR USA AND CANADA]

< WIRING DIAGRAM >

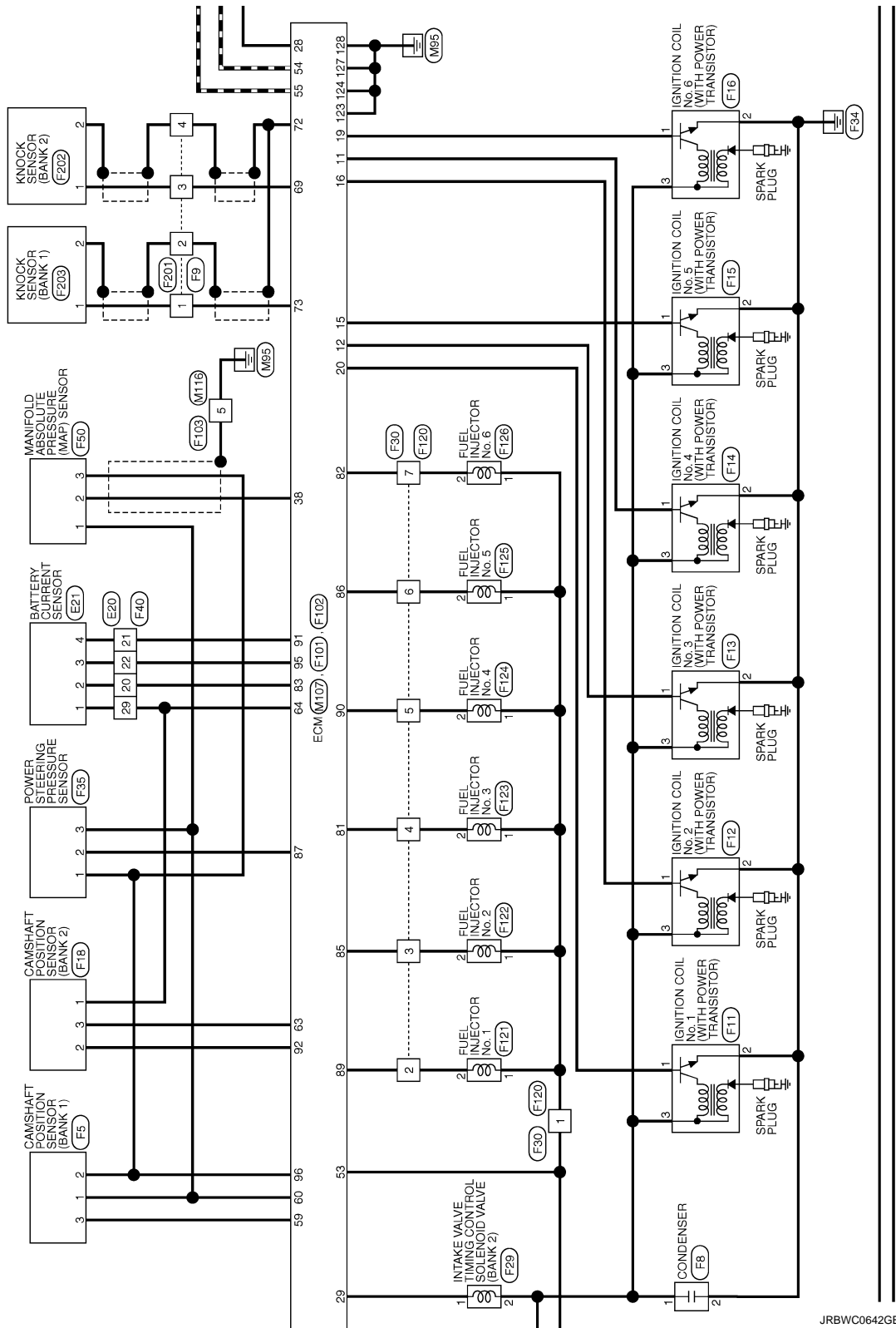

JRBWC0642GB

A

EC

C

D

E

F

G

H

I

J

K

L

M

N

O

P

# ENGINE CONTROL SYSTEM

< WIRING DIAGRAM >

[VQ37VHR FOR USA AND CANADA]

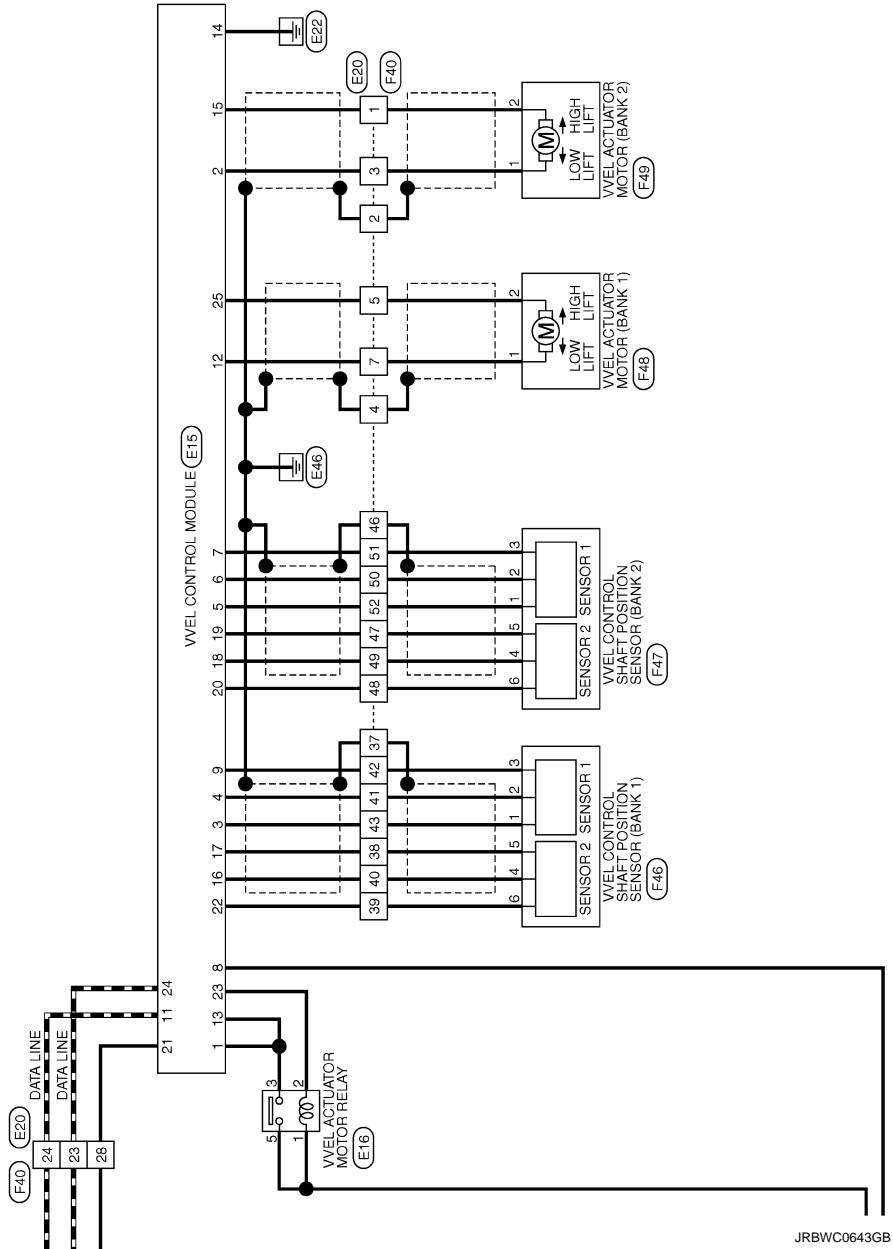

# DIAGNOSIS AND REPAIR WORKFLOW

< BASIC INSPECTION >

[VQ37VHR FOR USA AND CANADA]

## BASIC INSPECTION

### DIAGNOSIS AND REPAIR WORKFLOW

Work Flow

INFOID:000000007202157

A

EC

#### OVERALL SEQUENCE

C

D

E

F

G

H

I

J

K

L

M

N

O

P

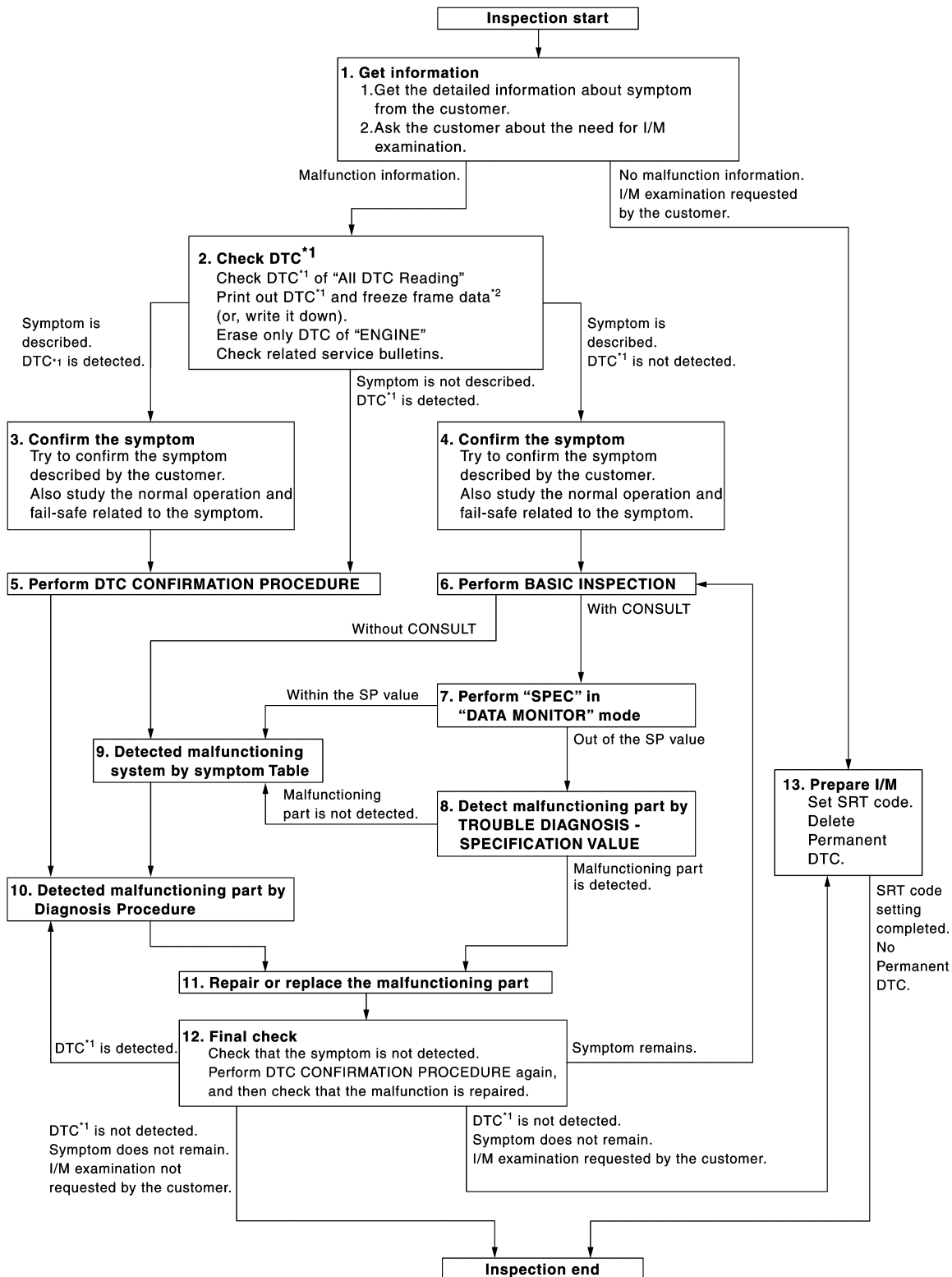

JSBIA0123GB

# DIAGNOSIS AND REPAIR WORKFLOW

[VQ37VHR FOR USA AND CANADA]

< BASIC INSPECTION >

\*1: Include 1st trip DTC.

\*2: Include 1st trip freeze frame data.

## DETAILED FLOW

### 1. GET INFORMATION FOR SYMPTOM

---

1. Get the detailed information from the customer about the symptom (the condition and the environment when the incident/malfunction occurred) using the "Diagnostic Work Sheet". (Refer to [EC-142, "Diagnostic Work Sheet"](#).)
2. Ask if the customer requests I/M examination.

Malfunction information, obtained>>GO TO 2.

No Malfunction information, but a request for I/M examination>>GO TO 13.

### 2. CHECK DTC

---

1. Check DTC of "All DTC Reading".
2. Perform the following procedure if DTC is displayed.
  - Record DTC and freeze frame data. (Print them out with CONSULT or GST.)
  - Erase only DTC of "ENGINE".
    - ⊗ With CONSULT: Refer to "How to Erase DTC and 1st Trip DTC" in [EC-88, "CONSULT Function"](#).
    - ⊗ Without CONSULT: Refer to "How to Erase Self-diagnostic Results" in [EC-85, "On Board Diagnosis Function"](#).
  - Turn ignition switch OFF.
  - Study the relationship between the cause detected by DTC and the symptom described by the customer. (Symptom Table is useful. Refer to [EC-532, "Symptom Table"](#).)
3. Check related service bulletins for information.

Are any symptoms described and any DTCs detected?

Symptom is described, DTC is detected>>GO TO 3.

Symptom is described, DTC is not detected>>GO TO 4.

Symptom is not described, DTC is detected>>GO TO 5.

### 3. CONFIRM THE SYMPTOM

---

Try to confirm the symptom described by the customer (except MIL ON).

Also study the normal operation and fail-safe related to the symptom. Refer to [EC-537, "Description"](#) and [EC-114, "Fail safe"](#).

Diagnosis Work Sheet is useful to verify the incident.

Verify relation between the symptom and the condition when the symptom is detected.

>> GO TO 5.

### 4. CONFIRM THE SYMPTOM

---

Try to confirm the symptom described by the customer.

Also study the normal operation and fail-safe related to the symptom. Refer to [EC-537, "Description"](#) and [EC-114, "Fail safe"](#).

Diagnosis Work Sheet is useful to verify the incident.

Verify relation between the symptom and the condition when the symptom is detected.

>> GO TO 6.

### 5. PERFORM DTC CONFIRMATION PROCEDURE

---

Perform DTC CONFIRMATION PROCEDURE for the displayed DTC, and then make sure that DTC is detected again.

If two or more DTCs are detected, refer to [EC-116, "DTC Inspection Priority Chart"](#) and determine trouble diagnosis order.

#### NOTE:

- Freeze frame data is useful if the DTC is not detected.

# DIAGNOSIS AND REPAIR WORKFLOW

[VQ37VHR FOR USA AND CANADA]

## < BASIC INSPECTION >

- Perform Component Function Check if DTC CONFIRMATION PROCEDURE is not included on Service Manual. This simplified check procedure is an effective alternative though DTC cannot be detected during this check.  
If the result of Component Function Check is NG, it is the same as the detection of DTC by DTC CONFIRMATION PROCEDURE.

### Is DTC detected?

YES >> GO TO 10.

NO >> Check according to [GI-44, "Intermittent Incident"](#).

## 6. PERFORM BASIC INSPECTION

Perform [EC-154, "Work Procedure"](#).

### Do you have CONSULT?

YES >> GO TO 7.

NO >> GO TO 9.

## 7. PERFORM SPEC IN DATA MONITOR MODE

### With CONSULT

Make sure that "MAS A/F SE-B1", "MAS A/F SE-B2", "B/FUEL SCHDL", "A/F ALPHA-B1" and "A/F ALPHA-B2" are within the SP value using CONSULT "SPEC" in "DATA MONITOR" mode of "ENGINE". Refer to [EC-172, "Component Function Check"](#).

### Is the measurement value within the SP value?

YES >> GO TO 9.

NO >> GO TO 8.

## 8. DETECT MALFUNCTIONING PART BY TROUBLE DIAGNOSIS - SPECIFICATION VALUE

Detect malfunctioning part according to [EC-173, "Diagnosis Procedure"](#).

### Is a malfunctioning part detected?

YES >> GO TO 11.

NO >> GO TO 9.

## 9. DETECT MALFUNCTIONING SYSTEM BY SYMPTOM TABLE

Detect malfunctioning system according to [EC-532, "Symptom Table"](#) based on the confirmed symptom in step 4, and determine the trouble diagnosis order based on possible causes and symptoms.

>> GO TO 10.

## 10. DETECT MALFUNCTIONING PART BY DIAGNOSIS PROCEDURE

Inspect according to Diagnosis Procedure of the system.

### **NOTE:**



The Diagnosis Procedure in EC section described based on open circuit inspection. A short circuit inspection is also required for the circuit check in the Diagnosis Procedure. For details, refer to [GI-47, "Circuit Inspection"](#).

### Is a malfunctioning part detected?

YES >> GO TO 11.

NO >> Monitor input data from related sensors or check voltage of related ECM terminals using CONSULT. Refer to [EC-98, "Reference Value"](#).

## 11. REPAIR OR REPLACE THE MALFUNCTIONING PART

1. Repair or replace the malfunctioning part.
2. Reconnect parts or connectors disconnected during Diagnosis Procedure again after repair and replacement.
3. Check DTC. If DTC is displayed, erase it.
  -  With CONSULT: Refer to "How to Erase DTC and 1st Trip DTC" in [EC-88, "CONSULT Function"](#).
  -  Without CONSULT: Refer to "How to Erase Self-diagnostic Results" in [EC-85, "On Board Diagnosis Function"](#).

>> GO TO 12.

# DIAGNOSIS AND REPAIR WORKFLOW

< BASIC INSPECTION >

[VQ37VHR FOR USA AND CANADA]

## 12. FINAL CHECK

When DTC was detected in step 2, perform DTC CONFIRMATION PROCEDURE or Component Function Check again, and then make sure that the malfunction have been completely repaired.

When symptom was described from the customer, refer to confirmed symptom in step 3 or 4, and make sure that the symptom is not detected.

Is DTC detected and does symptom remain?

YES-1 >> DTC is detected: GO TO 10.

YES-2 >> Symptom remains: GO TO 6.

NO-1 >> No request for I/M examination from the customer: Before returning the vehicle to the customer, always erase unnecessary DTC in ECM and TCM (⊗) With CONSULT: Refer to "How to Read DTC and 1st Trip DTC" in [EC-88. "CONSULT Function"](#), (⊗) Without CONSULT: Refer to "How to Read Self-diagnostic Results" in [EC-85. "On Board Diagnosis Function"](#).

NO-2 >> I/M examination, requested from the customer: GO TO 13.

## 13. PREPARE FOR I/M EXAMINATION

1. Set SRT codes. Refer to [EC-160. "Description"](#).
2. Erase permanent DTCs. Refer to [EC-166. "Description"](#).

>> INSPECTION END.

## Diagnostic Work Sheet

INFOID:000000006882824

### DESCRIPTION

There are many operating conditions that lead to the malfunction of engine components. A good grasp of such conditions can make troubleshooting faster and more accurate.

In general, each customer feels differently about an incident. It is important to fully understand the symptoms or conditions for a customer complaint.

Utilize a diagnostic worksheet like the WORKSHEET SAMPLE below in order to organize all the information for troubleshooting.

Some conditions may cause the MIL to illuminate steady or blink and DTC to be detected. Examples:

- Vehicle ran out of fuel, which caused the engine to misfire.
- Fuel filler cap was left off or incorrectly screwed on, allowing fuel to evaporate into the atmosphere.

### KEY POINTS

**WHAT** ..... Vehicle & engine model  
**WHEN** ..... Date, Frequencies  
**WHERE**..... Road conditions  
**HOW** ..... Operating conditions,  
Weather conditions,  
Symptoms

SEF907L

**DIAGNOSIS AND REPAIR WORKFLOW**

&lt; BASIC INSPECTION &gt;

**[VQ37VHR FOR USA AND CANADA]****WORKSHEET SAMPLE**

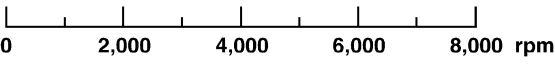
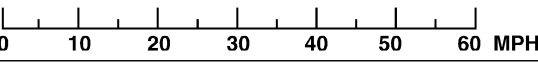
|                            |                                       |  |                 |
|----------------------------|---------------------------------------|--|-----------------|
| Customer name MR/MS        |                                       | Model & Year   | VIN             |
| Engine #                   |                                       | Trans.   | Mileage         |
| Incident Date              |                                       | Manuf. Date  | In Service Date |
| Fuel and fuel filler cap   |                                       | <input type="checkbox"/> Vehicle ran out of fuel causing misfire<br><input type="checkbox"/> Fuel filler cap was left off or incorrectly screwed on.   |                 |
| Symptoms                   | <input type="checkbox"/> Startability | <input type="checkbox"/> Impossible to start <input type="checkbox"/> No combustion <input type="checkbox"/> Partial combustion<br><input type="checkbox"/> Partial combustion affected by throttle position<br><input type="checkbox"/> Partial combustion NOT affected by throttle position<br><input type="checkbox"/> Possible but hard to start <input type="checkbox"/> Others [    ]  |                 |
|                            | <input type="checkbox"/> Idling       | <input type="checkbox"/> No fast idle <input type="checkbox"/> Unstable <input type="checkbox"/> High idle <input type="checkbox"/> Low idle<br><input type="checkbox"/> Others [    ]   |                 |
|                            | <input type="checkbox"/> Driveability | <input type="checkbox"/> Stumble <input type="checkbox"/> Surge <input type="checkbox"/> Knock <input type="checkbox"/> Lack of power<br><input type="checkbox"/> Intake backfire <input type="checkbox"/> Exhaust backfire<br><input type="checkbox"/> Others [    ]  |                 |
|                            | <input type="checkbox"/> Engine stall | <input type="checkbox"/> At the time of start <input type="checkbox"/> While idling<br><input type="checkbox"/> While accelerating <input type="checkbox"/> While decelerating<br><input type="checkbox"/> Just after stopping <input type="checkbox"/> While loading  |                 |
| Incident occurrence        |                                       | <input type="checkbox"/> Just after delivery <input type="checkbox"/> Recently<br><input type="checkbox"/> In the morning <input type="checkbox"/> At night <input type="checkbox"/> In the daytime  |                 |
| Frequency                  |                                       | <input type="checkbox"/> All the time <input type="checkbox"/> Under certain conditions <input type="checkbox"/> Sometimes   |                 |
| Weather conditions         |                                       | <input type="checkbox"/> Not affected  |                 |
|                            | Weather                               | <input type="checkbox"/> Fine <input type="checkbox"/> Raining <input type="checkbox"/> Snowing <input type="checkbox"/> Others [    ]   |                 |
|                            | Temperature                           | <input type="checkbox"/> Hot <input type="checkbox"/> Warm <input type="checkbox"/> Cool <input type="checkbox"/> Cold <input type="checkbox"/> Humid   °F   |                 |
| Engine conditions          |                                       | <input type="checkbox"/> Cold <input type="checkbox"/> During warm-up <input type="checkbox"/> After warm-up<br><br>Engine speed <br>0      2,000      4,000      6,000      8,000 rpm   |                 |
| Road conditions            |                                       | <input type="checkbox"/> In town <input type="checkbox"/> In suburbs <input type="checkbox"/> Highway <input type="checkbox"/> Off road (up/down)  |                 |
| Driving conditions         |                                       | <input type="checkbox"/> Not affected<br><input type="checkbox"/> At starting <input type="checkbox"/> While idling <input type="checkbox"/> At racing<br><input type="checkbox"/> While accelerating <input type="checkbox"/> While cruising<br><input type="checkbox"/> While decelerating <input type="checkbox"/> While turning (RH/LH)<br><br>Vehicle speed <br>0      10      20      30      40      50      60 MPH |                 |
| Malfunction indicator lamp |                                       | <input type="checkbox"/> Turned on <input type="checkbox"/> Not turned on  |                 |

MTBL0017

A  
EC  
C  
D  
E  
F  
G  
H  
I  
J  
K  
L  
M  
N  
O  
P

## ADDITIONAL SERVICE WHEN REPLACING ECM

< BASIC INSPECTION >

[VQ37VHR FOR USA AND CANADA]

---

### ADDITIONAL SERVICE WHEN REPLACING ECM

#### Description

INFOID:000000006882825

When replacing ECM, the following procedure must be performed.

#### Work Procedure

INFOID:000000006882826

**1.**PERFORM INITIALIZATION OF IVIS (NATS) SYSTEM AND REGISTRATION OF ALL IVIS (NATS) IGNITION KEY IDS

---

Refer to [SEC-39, "ECM : Work Procedure"](#).

>> GO TO 2.

**2.**PERFORM VIN REGISTRATION

---

Refer to [EC-146, "Work Procedure"](#).

>> GO TO 3.

**3.**PERFORM ACCELERATOR PEDAL RELEASED POSITION LEARNING

---

Refer to [EC-147, "Work Procedure"](#).

>> GO TO 4.

**4.**PERFORM THROTTLE VALVE CLOSED POSITION LEARNING

---

Refer to [EC-148, "Work Procedure"](#).

>> GO TO 5.

**5.**PERFORM IDLE AIR VOLUME LEARNING

---

Refer to [EC-149, "Work Procedure"](#).

>> END



# ADDITIONAL SERVICE WHEN REPLACING VVEL CONTROL MODULE

< BASIC INSPECTION >

[VQ37VHR FOR USA AND CANADA]

## ADDITIONAL SERVICE WHEN REPLACING VVEL CONTROL MODULE

### Description

INFOID:000000006882827

When replacing VVEL control module, the following procedure must be performed.

### Work Procedure

INFOID:000000006882828

#### 1. PERFORM IDLE AIR VOLUME LEARNING

Refer to [EC-149, "Work Procedure"](#).

>> END

A

EC

C

D

E

F

G

H

I

J

K

L

M

N

O

P

## VIN REGISTRATION

### Description

INFOID:000000006882829

VIN Registration is an operation to registering VIN in ECM. It must be performed each time ECM is replaced.

**NOTE:**

Accurate VIN which is registered in ECM may be required for Inspection & Maintenance (I/M).

### Work Procedure

INFOID:000000006882830

#### 1. CHECK VIN

---

Check the VIN of the vehicle and note it. Refer to [GI-35. "Information About Identification or Model Code"](#).

>> GO TO 2.

#### 2. PERFORM VIN REGISTRATION

 **With CONSULT**

1. Turn ignition switch ON and engine stopped.
2. Select "VIN REGISTRATION" in "WORK SUPPORT" mode.
3. Follow the instruction of CONSULT display.

>> END

# ACCELERATOR PEDAL RELEASED POSITION LEARNING

< BASIC INSPECTION >

[VQ37VHR FOR USA AND CANADA]

## ACCELERATOR PEDAL RELEASED POSITION LEARNING

### Description

INFOID:000000006882831

Accelerator Pedal Released Position Learning is a function of ECM to learn the fully released position of the accelerator pedal by monitoring the accelerator pedal position sensor output signal. It must be performed each time the harness connector of the accelerator pedal position sensor or ECM is disconnected.

A

EC

### Work Procedure

INFOID:000000006882832

C

#### 1. START

1. Make sure that accelerator pedal is fully released.
2. Turn ignition switch ON and wait at least 2 seconds.
3. Turn ignition switch OFF and wait at least 10 seconds.
4. Turn ignition switch ON and wait at least 2 seconds.
5. Turn ignition switch OFF and wait at least 10 seconds.

D

E

>> END

F

G

H

I

J

K

L

M

N

O

P

# THROTTLE VALVE CLOSED POSITION LEARNING

< BASIC INSPECTION >

[VQ37VHR FOR USA AND CANADA]

## THROTTLE VALVE CLOSED POSITION LEARNING

### Description

INFOID:000000006882833

Throttle Valve Closed Position Learning is a function of ECM to learn the fully closed position of the throttle valve by monitoring the throttle position sensor output signal. It must be performed each time harness connector of electric throttle control actuator or ECM is disconnected or electric throttle control actuator is cleaned.

### Work Procedure

INFOID:000000006882834

#### 1. START

##### Ⓟ With CONSULT

1. Turn ignition switch ON.
2. Select "CLSD THL POS LEARN" in "WORK SUPPORT" mode.
3. Follow the instructions on the CONSULT display.
4. Turn ignition switch OFF and wait at least 10 seconds.
5. Check that throttle valve moves during the above 10 seconds by confirming the operating sound.

##### ⓧ Without CONSULT

1. Start the engine.

##### **NOTE:**

Coolant temperature is less than 25°C (77°F) before engine starts.

2. Warm up the engine until engine coolant temperature reaches 65°C (149°F).
3. Turn ignition switch OFF and wait at least 10 seconds.
4. Check that throttle valve moves during the above 10 seconds by confirming the operating sound.

>> END

## IDLE AIR VOLUME LEARNING

### Description

INFOID:000000006882835

Idle Air Volume Learning is a function of ECM to learn the idle air volume that keeps engine idle speed within the specific range. It must be performed under the following conditions:

- Each time electric throttle control actuator or ECM is replaced.
- Each time VVEL actuator sub assembly or VVEL control module is replaced.
- Idle speed or ignition timing is out of specification.

### Work Procedure

INFOID:000000006882836

#### 1. PRECONDITIONING

Make sure that all of the following conditions are satisfied.

Learning will be cancelled if any of the following conditions are missed for even a moment.

- Battery voltage: More than 12.9 V (At idle)
- Engine coolant temperature: 70 - 105°C (158 - 221°F)
- Selector lever: P or N
- Electric load switch: OFF  
(Air conditioner, headlamp, rear window defogger)

**On vehicles equipped with daytime light systems, if the parking brake is applied before the engine is started the headlamp will not be illuminated.**

- Steering wheel: Neutral (Straight-ahead position)
- Vehicle speed: Stopped
- Transmission: Warmed-up
- With CONSULT: Drive vehicle until "ATF TEMP SE 1" in "DATA MONITOR" mode of "A/T" system indicates less than 0.9V.
- Without CONSULT: Drive vehicle for 10 minutes.

Do you have CONSULT?

- YES >> GO TO 2.
- NO >> GO TO 3.

#### 2. PERFORM IDLE AIR VOLUME LEARNING

##### With CONSULT

1. Perform Accelerator Pedal Released Position Learning. Refer to [EC-147, "Work Procedure"](#).
2. Perform Throttle Valve Closed Position Learning. [EC-148, "Work Procedure"](#).
3. Start engine and warm it up to normal operating temperature.
4. Select "IDLE AIR VOL LEARN" in "WORK SUPPORT" mode.
5. Touch "START" and wait 20 seconds.

Is "CMPLT" displayed on CONSULT screen?

- YES >> GO TO 4.
- NO >> GO TO 5.

#### 3. PERFORM IDLE AIR VOLUME LEARNING

##### Without CONSULT

**NOTE:**

- It is better to count the time accurately with a clock.
- It is impossible to switch the diagnostic mode when an accelerator pedal position sensor circuit has a malfunction.

1. Perform Accelerator Pedal Released Position Learning. Refer to [EC-147, "Work Procedure"](#).
2. Perform Throttle Valve Closed Position Learning. [EC-148, "Work Procedure"](#).
3. Start engine and warm it up to normal operating temperature.
4. Turn ignition switch OFF and wait at least 10 seconds.
5. Confirm that accelerator pedal is fully released, turn ignition switch ON and wait 3 seconds.
6. Repeat the following procedure quickly five times within 5 seconds.
  - Fully depress the accelerator pedal.
  - Fully release the accelerator pedal.
7. Wait 7 seconds, fully depress the accelerator pedal for approx. 20 seconds until the MIL stops blinking and illuminates.

# IDLE AIR VOLUME LEARNING

[VQ37VHR FOR USA AND CANADA]

< BASIC INSPECTION >

8. Fully release the accelerator pedal within 3 seconds after the MIL illuminates.
9. Start engine and let it idle.
10. Wait 20 seconds.

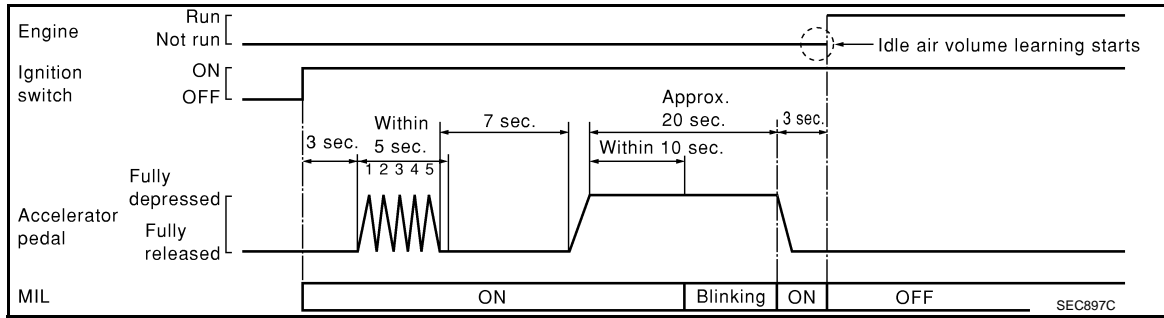

>> GO TO 4.

## 4. CHECK IDLE SPEED AND IGNITION TIMING

1. Start engine and warm it up to normal operating temperature.
2. Let it idle for 20 seconds.
3. Rev up the engine two or three times and make sure that idle speed and ignition timing are within the specifications. Refer to [EC-545. "Idle Speed"](#) and [EC-545. "Ignition Timing"](#).

Is the inspection result normal?

- YES >> INSPECTION END  
NO >> GO TO 5.

## 5. DETECT MALFUNCTIONING PART-I

Check the following

- Check that throttle valve is fully closed.
- Check PCV valve operation.
- Check that downstream of throttle valve is free from air leakage.

Is the inspection result normal?

- YES >> GO TO 6.  
NO >> Repair or replace malfunctioning part.

## 6. DETECT MALFUNCTIONING PART-II

Engine component parts and their installation condition are questionable. Check and eliminate the cause of the incident.

It is useful to perform "TROUBLE DIAGNOSIS - SPECIFICATION VALUE". Refer to [EC-172. "Description"](#).

If any of the following conditions occur after the engine has started, eliminate the cause of the incident and perform Idle Air Volume Learning again:

- Engine stalls.
- Erroneous idle.

>> INSPECTION END

# VVEL CONTROL SHAFT POSITION SENSOR ADJUSTMENT

< BASIC INSPECTION >

[VQ37VHR FOR USA AND CANADA]

## VVEL CONTROL SHAFT POSITION SENSOR ADJUSTMENT

### Description

INFOID:000000006882837

VVEL control shaft position sensor adjustment is an operation to adjust the initial position angle that is the basis for the VVEL control shaft position sensor.

It must be performed each time VVEL actuator sub assembly is replaced.

#### CAUTION:

- It must be performed only on the replaced bank side.
- It must not be performed except when VVEL actuator sub assembly is replaced. If by any chance the adjustment is performed, replace VVEL actuator sub assembly.

### Work Procedure

INFOID:000000006882838

#### 1. START

Do you have CONSULT?

Do you have CONSULT?

YES >> GO TO 2.

NO >> GO TO 3.

#### 2. PERFORM VVEL CONTROL SHAFT POSITION SENSOR ADJUSTMENT

##### With CONSULT

1. Turn ignition switch ON.
2. Select "VVEL POS SEN ADJ PREP" in "WORK SUPPORT" mode with CONSULT.
3. Touch "Start" and wait a few seconds.
4. Make sure the "CMPLT" is displayed on CONSULT screen.
5. Select "VVEL POSITION SEN- B1" or "VVEL POSITION SEN- B2" in "DATA MONITOR" mode with CONSULT.
6. Loosen the VVEL control shaft position sensor mounting bolt (1).
7. Turn the VVEL control shaft position sensor (2) right and left while monitoring the output voltage of "VVEL POSITION SEN- B1" or "VVEL POSITION SEN- B2" and adjust the output voltage to be within the standard value.

**Voltage : 500 ± 48 mV**

8. Tighten the VVEL control shaft position sensor mounting bolt.

 **: 7.0 N•m (0.71 kg-m, 62 in-lb)**

9. Reconfirm that the output voltage of "VVEL POSITION SEN- B1" or "VVEL POSITION SEN- B2" is within the standard value.

**Voltage : 500 ± 48 mV**

#### NOTE:

If it varies from the standard value after the bolt is tightened, perform steps 6 to 8 again.

10. Turn ignition switch OFF and wait at least 10 seconds.
11. Start engine and warm it up to normal operating temperature.
12. Turn ignition switch OFF and wait at least 10 seconds.
13. Perform idle air volume learning. Refer to [EC-149, "Work Procedure"](#).

>> INSPECTION END

#### 3. PERFORM VVEL CONTROL SHAFT POSITION SENSOR ADJUSTMENT

##### Without CONSULT

1. Disconnect VVEL control shaft position sensor harness connector.
2. Remove VVEL actuator motor relay.
3. Turn ignition switch ON, wait at least 5 seconds and then turn OFF.
4. Reconnect all harness connectors disconnected.

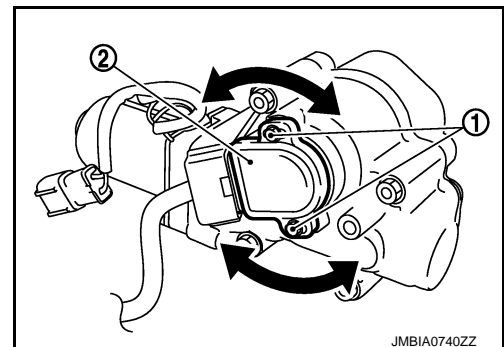

# VVEL CONTROL SHAFT POSITION SENSOR ADJUSTMENT

< BASIC INSPECTION >

[VQ37VHR FOR USA AND CANADA]

5. Install VVEL actuator motor relay.
6. Turn ignition switch ON and wait at least 5 seconds.
7. Loosen the VVEL control shaft position sensor mounting bolt (1).
8. Turn the VVEL control shaft position sensor (2) right and left while monitoring the output voltage between the VVEL control module terminals with a tester and adjust the output voltage to be within the standard value.

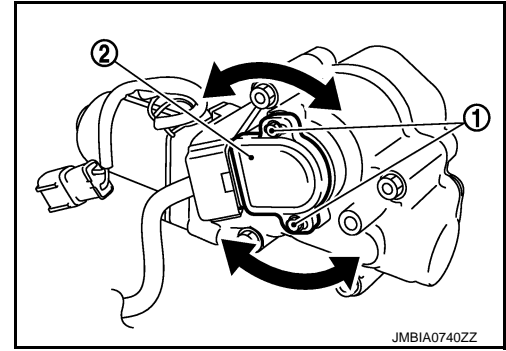

| VVEL control module |           |          |          | Voltage     |
|---------------------|-----------|----------|----------|-------------|
| Bank                | Connector | +        | -        |             |
|                     |           | Terminal | Terminal |             |
| 1                   | E15       | 3        | 4        | 500 ± 48 mV |
| 2                   |           | 5        | 6        |             |

9. Tighten the VVEL control shaft position sensor mounting bolt.



**: 7.0 N•m (0.71 kg-m, 62 in-lb)**

10. Reconfirm that the output voltage of VVEL control shaft position sensor is within the standard value.

| VVEL control module |           |          |          | Voltage     |
|---------------------|-----------|----------|----------|-------------|
| Bank                | Connector | +        | -        |             |
|                     |           | Terminal | Terminal |             |
| 1                   | E15       | 3        | 4        | 500 ± 48 mV |
| 2                   |           | 5        | 6        |             |

**NOTE:**

If it varies from the standard value after the bolt is tightened, perform steps 7 to 9 again.

11. Turn ignition switch OFF and wait at least 10 seconds.
12. Start engine and warm it up to normal operating temperature.
13. Turn ignition switch OFF and wait at least 10 seconds.
14. Perform idle air volume learning. Refer to [EC-149, "Work Procedure"](#).

>> INSPECTION END



# MIXTURE RATIO SELF-LEARNING VALUE CLEAR

< BASIC INSPECTION >

[VQ37VHR FOR USA AND CANADA]

## MIXTURE RATIO SELF-LEARNING VALUE CLEAR

### Description

INFOID:000000006882839

This describes how to erase the mixture ratio self-learning value. For the actual procedure, follow the instructions in "Diagnosis Procedure".

### Work Procedure

INFOID:000000006882840

#### 1. START

##### With CONSULT

1. Start engine and warm it up to normal operating temperature.
2. Select "SELF-LEARNING CONT" in "WORK SUPPORT" mode with CONSULT.
3. Clear mixture ratio self-learning value by touching "CLEAR".

##### With GST

1. Start engine and warm it up to normal operating temperature.
2. Turn ignition switch OFF.
3. Disconnect mass air flow sensor (bank 1) harness connector.
4. Restart engine and let it idle for at least 5 seconds.
5. Stop engine and reconnect mass air flow sensor (bank 1) harness connector.
6. Select Service \$03 with GST. Make sure DTC P0102 is detected.
7. Select Service \$04 with GST to erase the DTC P0102.

>> END

A

EC

C

D

E

F

G

H

I

J

K

L

M

N

O

P

## BASIC INSPECTION

### Work Procedure

INFOID:000000006882841

#### 1.INSPECTION START

1. Check service records for any recent repairs that may indicate a related malfunction, or a current need for scheduled maintenance.
2. Open engine hood and check the following:
  - Harness connectors for improper connections
  - Wiring harness for improper connections, pinches and cut
  - Vacuum hoses for splits, kinks and improper connections
  - Hoses and ducts for leaks
  - Air cleaner clogging
  - Gasket
3. Confirm that electrical or mechanical loads are not applied.
  - Headlamp switch is OFF.
  - Air conditioner switch is OFF.
  - Rear window defogger switch is OFF.
  - Steering wheel is in the straight-ahead position, etc.
4. Start engine and warm it up until engine coolant temperature indicator points the middle of gauge. Ensure engine stays below 1,000 rpm.

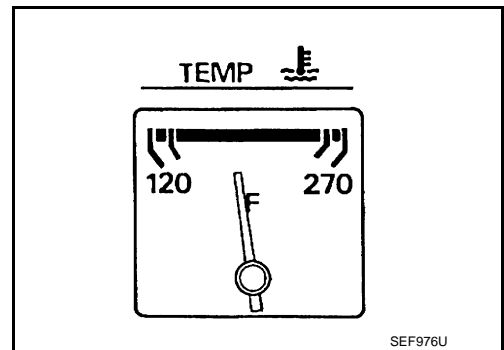
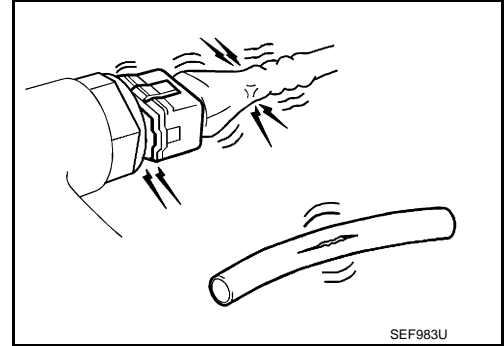

5. Run engine at about 2,000 rpm for about 2 minutes under no load.
6. Make sure that no DTC is displayed with CONSULT or GST.

Are any DTCs detected?

- YES >> GO TO 2.  
 NO >> GO TO 3.

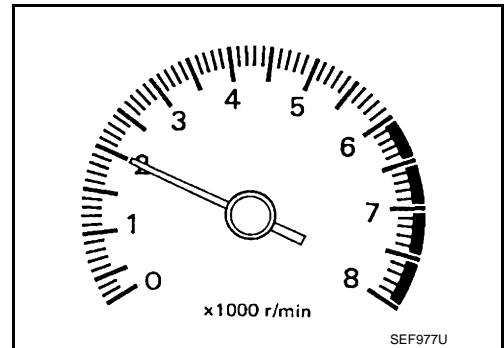

#### 2.REPAIR OR REPLACE

Repair or replace components as necessary according to corresponding Diagnosis Procedure.

>> GO TO 3

#### 3.CHECK IDLE SPEED

1. Run engine at about 2,000 rpm for about 2 minutes under no load.

# BASIC INSPECTION

[VQ37VHR FOR USA AND CANADA]

## < BASIC INSPECTION >

- Rev engine (2,000 to 3,000 rpm) two or three times under no load, then run engine at idle speed for about 1 minute.
- Check idle speed.  
For procedure, refer to [EC-538, "Inspection"](#).  
For specification, refer to [EC-545, "Idle Speed"](#).

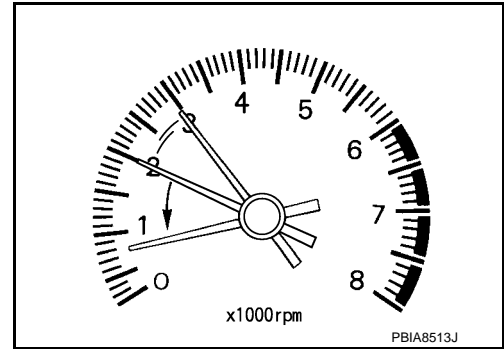

Is the inspection result normal?

- YES >> GO TO 10.  
NO >> GO TO 4.

## 4.PERFORM ACCELERATOR PEDAL RELEASED POSITION LEARNING

- Stop engine.
- Perform [EC-147, "Work Procedure"](#).

>> GO TO 5.

## 5.PERFORM THROTTLE VALVE CLOSED POSITION LEARNING

Perform [EC-148, "Work Procedure"](#).

>> GO TO 6.

## 6.PERFORM IDLE AIR VOLUME LEARNING

Perform [EC-149, "Work Procedure"](#).

Is Idle Air Volume Learning carried out successfully?

- YES >> GO TO 7.  
NO >> Follow the instruction of Idle Air Volume Learning. Then GO TO 4.

## 7.CHECK IDLE SPEED AGAIN

- Start engine and warm it up to normal operating temperature.
- Check idle speed.  
For procedure, refer to [EC-538, "Inspection"](#).  
For specification, refer to [EC-545, "Idle Speed"](#).

Is the inspection result normal?

- YES >> GO TO 10.  
NO >> GO TO 8.

## 8.DETECT MALFUNCTIONING PART

Check the Following.

- Check camshaft position sensor (PHASE) and circuit. Refer to [EC-319, "Component Inspection"](#).
- Check crankshaft position sensor (POS) and circuit. Refer to [EC-314, "Component Inspection"](#).

Is the inspection result normal?

- YES >> GO TO 9.  
NO >> Repair or replace. Then GO TO 4.

## 9.CHECK ECM FUNCTION

- Substitute with a non-malfunctioning ECM to check ECM function. (ECM may be the cause of the incident, although this is rare.)
- Perform initialization of IVIS (NATS) system and registration of all IVIS (NATS) ignition key IDs. Refer to [EC-144, "Work Procedure"](#).

>> GO TO 4.

## 10.CHECK IGNITION TIMING

- Run engine at idle.

# BASIC INSPECTION

[VQ37VHR FOR USA AND CANADA]

## < BASIC INSPECTION >

2. Check ignition timing with a timing light.

A :Timing indicator

For procedure, refer to [EC-539, "Inspection"](#).

For specification, refer to [EC-545, "Ignition Timing"](#).

Is the inspection result normal?

YES >> GO TO 19.

NO >> GO TO 11.

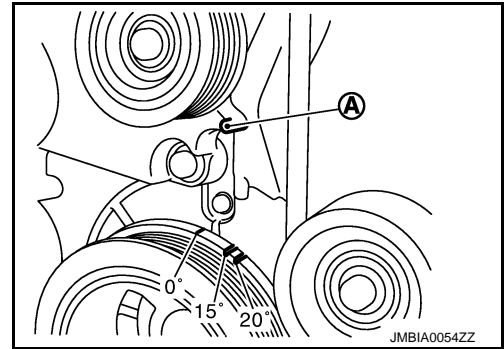

## 11. PERFORM ACCELERATOR PEDAL RELEASED POSITION LEARNING

1. Stop engine.
2. Perform [EC-147, "Work Procedure"](#).

>> GO TO 12.

## 12. PERFORM THROTTLE VALVE CLOSED POSITION LEARNING

Perform [EC-148, "Work Procedure"](#).

>> GO TO 13.

## 13. PERFORM IDLE AIR VOLUME LEARNING

Perform [EC-149, "Work Procedure"](#).

Is Idle Air Volume Learning carried out successfully?

YES >> GO TO 14.

NO >> Follow the instruction of Idle Air Volume Learning. Then GO TO 4.

## 14. CHECK IDLE SPEED AGAIN

1. Start engine and warm it up to normal operating temperature.
2. Check idle speed.

For procedure, refer to [EC-538, "Inspection"](#).

For specification, refer to [EC-545, "Idle Speed"](#).

Is the inspection result normal?

YES >> GO TO 15.

NO >> GO TO 17.

## 15. CHECK IGNITION TIMING AGAIN

1. Run engine at idle.
2. Check ignition timing with a timing light.

A :Timing indicator

For procedure, refer to [EC-539, "Inspection"](#).

For specification, refer to [EC-545, "Ignition Timing"](#).

Is the inspection result normal?

YES >> GO TO 19.

NO >> GO TO 16.

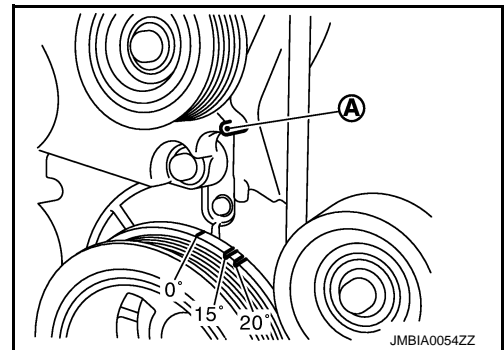

## 16. CHECK TIMING CHAIN INSTALLATION

Check timing chain installation. Refer to [EM-53, "Removal and Installation"](#).

Is the inspection result normal?

YES >> GO TO 17.

NO >> Repair the timing chain installation. Then GO TO 4.

# BASIC INSPECTION

< BASIC INSPECTION >

[VQ37VHR FOR USA AND CANADA]

---

## 17. DETECT MALFUNCTIONING PART

---

Check the following.

- Check camshaft position sensor (PHASE) and circuit. Refer to [EC-319, "Component Inspection"](#).
- Check crankshaft position sensor (POS) and circuit. Refer to [EC-314, "Component Inspection"](#).

Is the inspection result normal?

YES >> GO TO 18.

NO >> Repair or replace. Then GO TO 4.

---

## 18. CHECK ECM FUNCTION

---

1. Substitute with a non-malfunctioning ECM to check ECM function. (ECM may be the cause of the incident, although this is rare.)
2. Perform initialization of IVIS (NATS) system and registration of all IVIS (NATS) ignition key IDs. Refer to [EC-144, "Work Procedure"](#).

>> GO TO 4.

---

## 19. INSPECTION END

---

If ECM is replaced during this BASIC INSPECTION procedure, go to [EC-144, "Work Procedure"](#).

>> INSPECTION END

A

EC

C

D

E

F

G

H

I

J

K

L

M

N

O

P

# FUEL PRESSURE CHECK

[VQ37VHR FOR USA AND CANADA]

< BASIC INSPECTION >

## FUEL PRESSURE CHECK

### Work Procedure

INFOID:00000006882842

#### FUEL PRESSURE RELEASE

##### 1. FUEL PRESSURE RELEASE

① With CONSULT

1. Turn ignition switch ON.
2. Select ENGINE using CONSULT.
3. Perform "FUEL PRESSURE RELEASE" in "WORK SUPPORT" mode.
4. Start engine.
5. After engine stalls, crank it two or three times to release all fuel pressure.
6. Turn ignition switch OFF.

② Without CONSULT

1. Remove fuel pump fuse (1) located in IPDM E/R (2).
2. Start engine.
3. After engine stalls, crank it two or three times to release all fuel pressure.
4. Turn ignition switch OFF.
5. Reinstall fuel pump fuse after servicing fuel system.

>> INSPECTION END

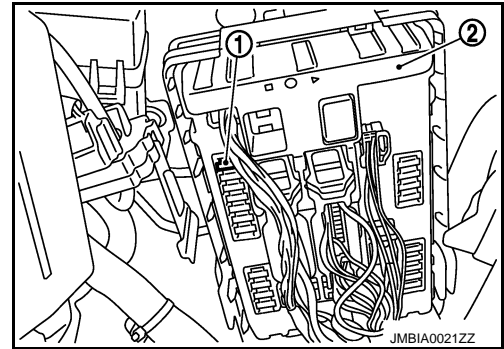

#### FUEL PRESSURE CHECK

##### 1. FUEL PRESSURE CHECK

1. Release fuel pressure to zero.
2. Install the inline fuel quick disconnected fitting (A) between fuel damper (1) and injector tube.

**CAUTION:**

**Before disconnecting fuel line, release fuel pressure from fuel line to eliminate danger.**

**NOTE:**

- Prepare pans or saucers under the disconnected fuel line because the fuel may spill out. The fuel pressure cannot be completely released because Y51 models do not have fuel return system.
- Use Fuel Pressure Gauge Kit (J-44321) to check fuel pressure.

3. Connect pressure gauge (B) to fuel pressure check adapter.
4. Turn ignition switch ON and check for fuel leakage.
5. Start engine and check for fuel leakage.
6. Read the indication of fuel pressure gauge.

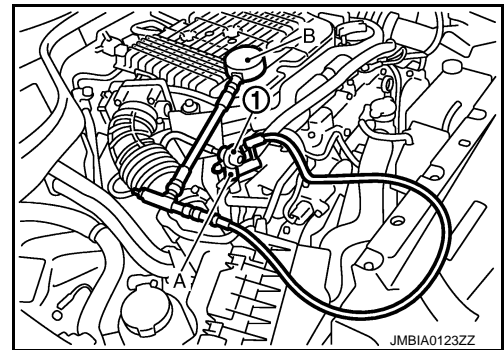

At idling : Approximately 350 kPa (3.5 bar, 3.57 kg/cm<sup>2</sup>, 51 psi)

Is the inspection result normal?

- YES >> INSPECTION END  
NO >> GO TO 2.

##### 2. CHECK FUEL HOSE AND FUEL TUBE

If result is unsatisfactory, check fuel hoses and fuel tubes for clogging.

Is the inspection result normal?

- YES >> Replace "fuel filter and fuel pump assembly".

# FUEL PRESSURE CHECK

< BASIC INSPECTION >

[VQ37VHR FOR USA AND CANADA]

NO >> Repair or replace.

A

**EC**

C

D

E

F

G

H

I

J

K

L

M

N

O

P

# HOW TO SET SRT CODE

< BASIC INSPECTION >

[VQ37VHR FOR USA AND CANADA]

## HOW TO SET SRT CODE

### Description

INFOID:000000006882843

### OUTLINE

In order to set all SRTs, the self-diagnoses as in the "SRT ITEM" table must have been performed at least once. Each diagnosis may require actual driving for a long period of time under various conditions.

### SRT ITEM

The table below shows required self-diagnostic items to set the SRT to "CMPLT".

| SRT item*1<br>(CONSULT indication) | Required self-diagnostic items to set the SRT to "CMPLT" | Corresponding DTC No. |
|------------------------------------|--|-----------------------|
| CATALYST                           | Three way catalyst function                              | P0420, P0430          |
| EVAP SYSTEM                        | EVAP control system purge flow monitoring                | P0441                 |
|                                    | EVAP control system                                      | P0456                 |
| HO2S                               | Air fuel ratio (A/F) sensor 1                            | P0133, P0153          |
|                                    | Heated oxygen sensor 2                                   | P0137, P0157          |
|                                    | Heated oxygen sensor 2                                   | P0138, P0158          |
|                                    | Heated oxygen sensor 2                                   | P0139, P0159          |
| EGR/VVT SYSTEM                     | Intake valve timing control function                     | P0011, P0021          |

\*1: Though displayed on the CONSULT screen, "HO2S HTR" is not SRT item.

### SRT SERVICE PROCEDURE

If a vehicle has failed the state emissions inspection due to one or more SRT items indicating "INCMP", review the flowchart diagnostic sequence, referring to the following flowchart.



# HOW TO SET SRT CODE

< BASIC INSPECTION >

[VQ37VHR FOR USA AND CANADA]

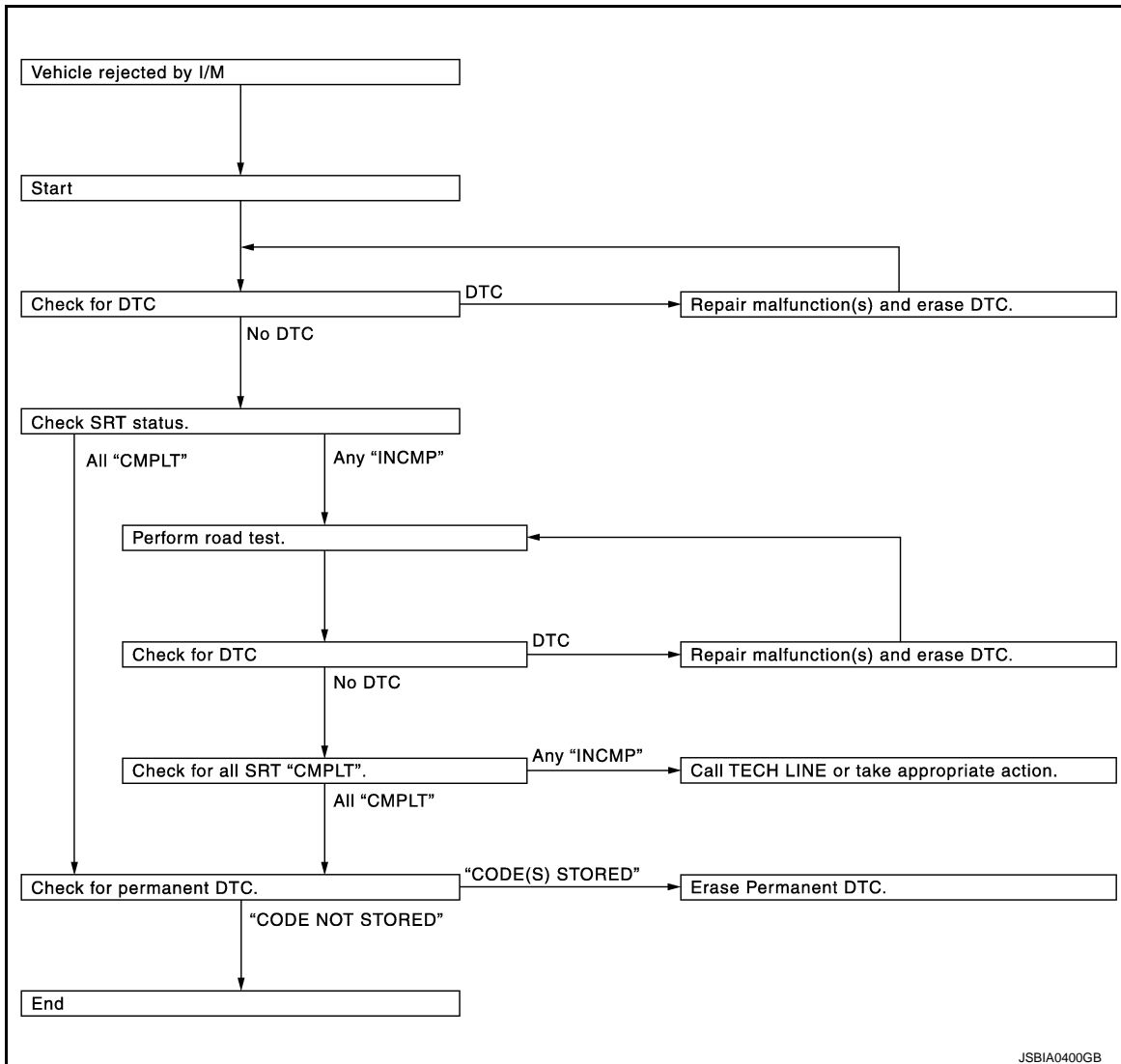

A

EC

C

D

E

F

G

H

I

J

K

## SRT Set Driving Pattern

INFOID:000000006882844

**CAUTION:**

L

M

N

O

P

# HOW TO SET SRT CODE

< BASIC INSPECTION >

[VQ37VHR FOR USA AND CANADA]

Always drive the vehicle in safe manner according to traffic conditions and obey all traffic laws.

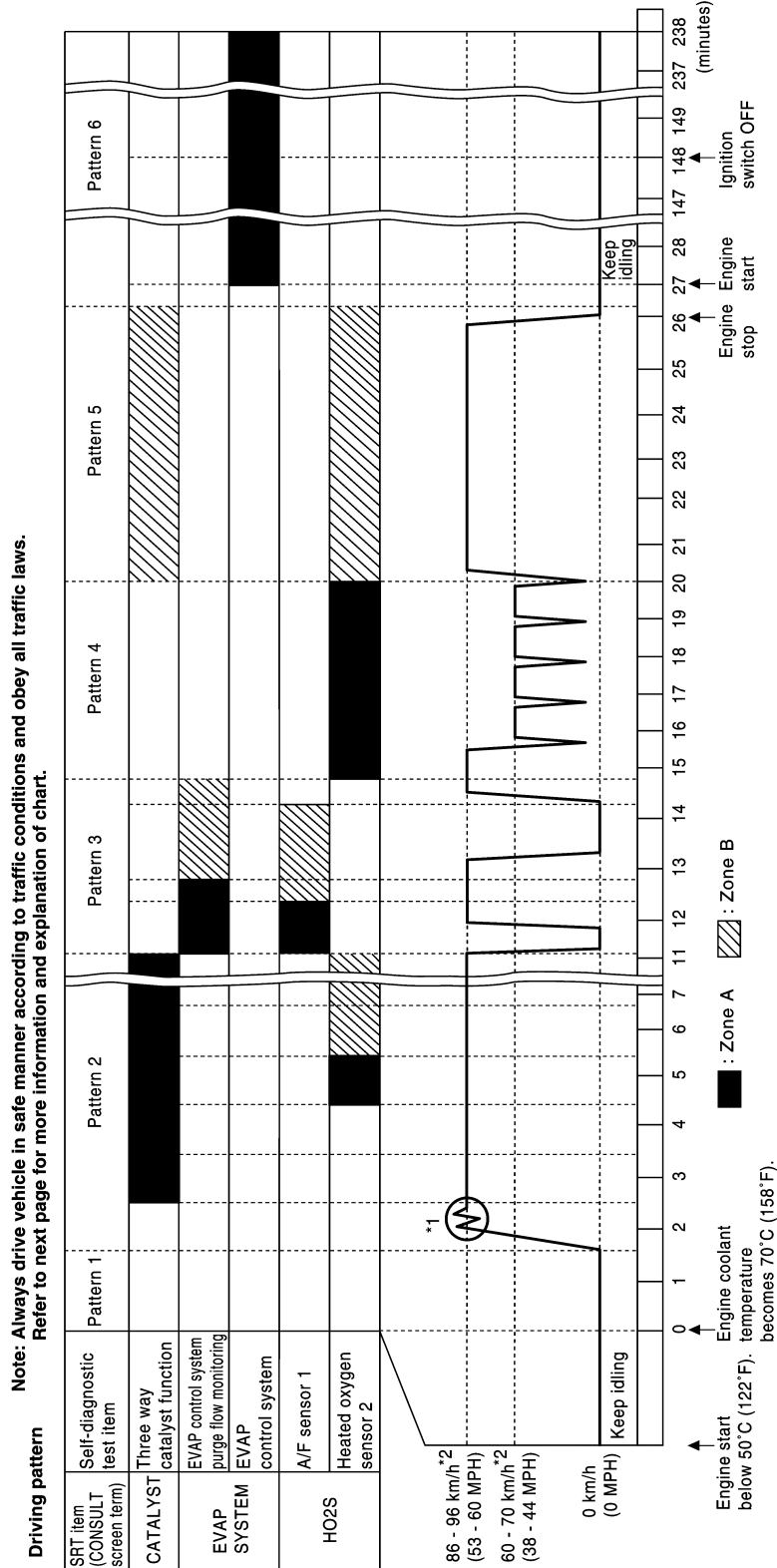

\*1: Depress the accelerator pedal until vehicle speed is 90 km/h (56 MPH), then release the accelerator pedal and keep it released for more than 10 seconds. Depress the accelerator pedal until vehicle speed is 90 km/h (56 MPH) again.

\*2: Checking the vehicle speed with GST is advised.

- The time required for each diagnosis varies with road surface conditions, weather, altitude, individual driving habits, etc.

Zone A refers to the range where the time, required for the diagnosis under normal conditions\*, is the shortest.

# HOW TO SET SRT CODE

[VQ37VHR FOR USA AND CANADA]

## < BASIC INSPECTION >

Zone B refers to the range where the diagnosis can still be performed if the diagnosis is not completed within zone A.

\*: Normal conditions refer to the following:

- Sea level
  - Flat road
  - Ambient air temperature: 20 - 30°C (68 - 86°F)
  - Diagnosis is performed as quickly as possible under normal conditions.
- Under different conditions [For example: ambient air temperature other than 20 - 30°C (68 - 86°F)], diagnosis may also be performed.

## Work Procedure

INFOID:000000006882845

### 1. CHECK DTC

Check DTC.

Is any DTC detected?

YES >> Repair malfunction(s) and erase DTC. Refer to [EC-117, "DTC Index"](#).

NO >> GO TO 2.

### 2. CHECK SRT STATUS

WITH CONSULT

Select "SRT STATUS" in "DTC & SRT CONFIRMATION" mode with CONSULT.

WITHOUT CONSULT

Perform "SRT status" mode with [EC-85, "On Board Diagnosis Function"](#).

WITH GST

Select Service \$01 with GST.

Is SRT code(s) set?

YES >> GO TO 12.

NO-1 >> With CONSULT: GO TO 3.

NO-2 >> Without CONSULT: GO TO 4.

### 3. DTC CONFIRMATION PROCEDURE

1. Select "SRT WORK SUPPORT" in "DTC & SRT CONFIRMATION" mode with CONSULT.
2. For SRT(s) that is not set, perform the corresponding "DTC CONFIRMATION PROCEDURE" according to the "Performance Priority" in the "SRT ITEM" table. Refer to [EC-160, "Description"](#).
3. Check DTC.

Is any DTC detected?

YES >> Repair malfunction(s) and erase DTC. Refer to [EC-117, "DTC Index"](#).

NO >> GO TO 11.

### 4. PERFORM ROAD TEST

- Check the "Performance Priority" in the "SRT ITEM" table. Refer to [EC-160, "Description"](#).
- Perform the most efficient SRT set driving pattern to set the SRT properly. Refer to [EC-161, "SRT Set Driving Pattern"](#).

In order to set all SRTs, the SRT set driving pattern must be performed at least once.

>> GO TO 5.

### 5. PATTERN 1

1. Check the vehicle condition;
  - Engine coolant temperature is -10 to 35°C (14 to 95°F).
  - Fuel tank temperature is more than 0°C (32°F).
2. Start the engine.
3. Keep engine idling until the engine coolant temperature is greater than 70°C (158°F)

#### NOTE:

ECM terminal voltage is follows;

- Engine coolant temperature
  - -10 to 35°C (14 to 95°F): 3.0 - 4.3 V
  - 70°(158°F): Less than 1.4 V

## HOW TO SET SRT CODE

[VQ37VHR FOR USA AND CANADA]

< BASIC INSPECTION >

- Fuel tank temperature: Less than 4.1 V  
Refer to [EC-98. "Reference Value"](#).

>> GO TO 6.

### 6.PATTERN 2

1. Drive the vehicle. And depress the accelerator pedal until vehicle speed is 90 km/h (56 MPH), then release the accelerator pedal and keep it released for more than 10 seconds.
2. Depress the accelerator pedal until vehicle speed is 90 km/h (56 MPH) again

#### NOTE:

- Checking the vehicle speed with GST is advised.
- When steady-state driving is performed again even after it is interrupted, each diagnosis can be conducted. In this case, the time required for diagnosis may be extended.

>> GO TO 7.

### 7.PATTERN 3

- Operate vehicle following the driving pattern shown in the figure.
- Release the accelerator pedal during deceleration of vehicle speed from 90 km/h (56 MPH) to 0 km/h (0 MPH).

>> GO TO 8.

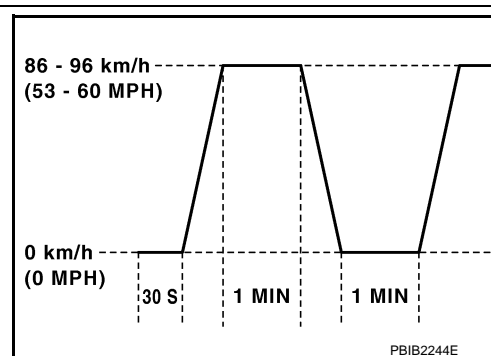

### 8.PATTERN 4

- Operate vehicle following the driving pattern shown in the figure.
- Drive the vehicle in a proper gear at 60 km/h (38 MPH) and maintain the speed.
- Release the accelerator pedal fully at least 5 seconds.
- Repeat the above two steps at least 5 times.

>> GO TO 9.

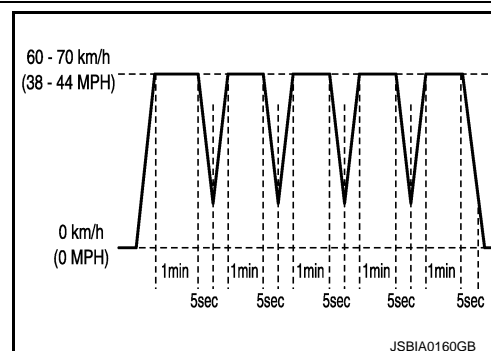

### 9.PATTERN 5

- The accelerator pedal must be held very steady during steady-state driving.
- If the accelerator pedal is moved, the test must be conducted again.

>> GO TO 10.

### 10.PATTERN 6

Start engine and wait at least 2 hours. Then turn ignition switch OFF and wait at least 90 minutes.

>> GO TO 11.

### 11.CHECK SRT STATUS

#### Ⓢ WITH CONSULT

Select "SRT STATUS" in "DTC & SRT CONFIRMATION" mode with CONSULT.

#### ⓧ WITHOUT CONSULT

Perform "SRT status" mode with [EC-85. "On Board Diagnosis Function"](#).

# HOW TO SET SRT CODE

[VQ37VHR FOR USA AND CANADA]

< BASIC INSPECTION >

 WITH GST

Select Service \$01 with GST.

Is SRT(s) set?

YES >> GO TO 12.

NO >> Call TECH LINE or take appropriate action.

## 12.CHECK PERMANENT DTC

### NOTE:

Permanent DTC cannot be checked with a tool other than CONSULT or GST.

 WITH CONSULT

Select "SRT STATUS" in "DTC & SRT CONFIRMATION" mode with CONSULT.

 WITH GST

Select Service \$0A with GST.

Is permanent DTC(s) detected?

YES >> Go to [EC-166, "Description"](#).

NO >> END

A

EC

C

D

E

F

G

H

I

J

K

L

M

N

O

P

# HOW TO ERASE PERMANENT DTC

< BASIC INSPECTION >

[VQ37VHR FOR USA AND CANADA]

## HOW TO ERASE PERMANENT DTC

### Description

INFOID:000000006882846

When a DTC is stored in ECM

When a DTC is stored in ECM and MIL is ON, a permanent DTC is erased with MIL shutoff if the same malfunction is not detected after performing the driving pattern for MIL shutoff three times in a row.

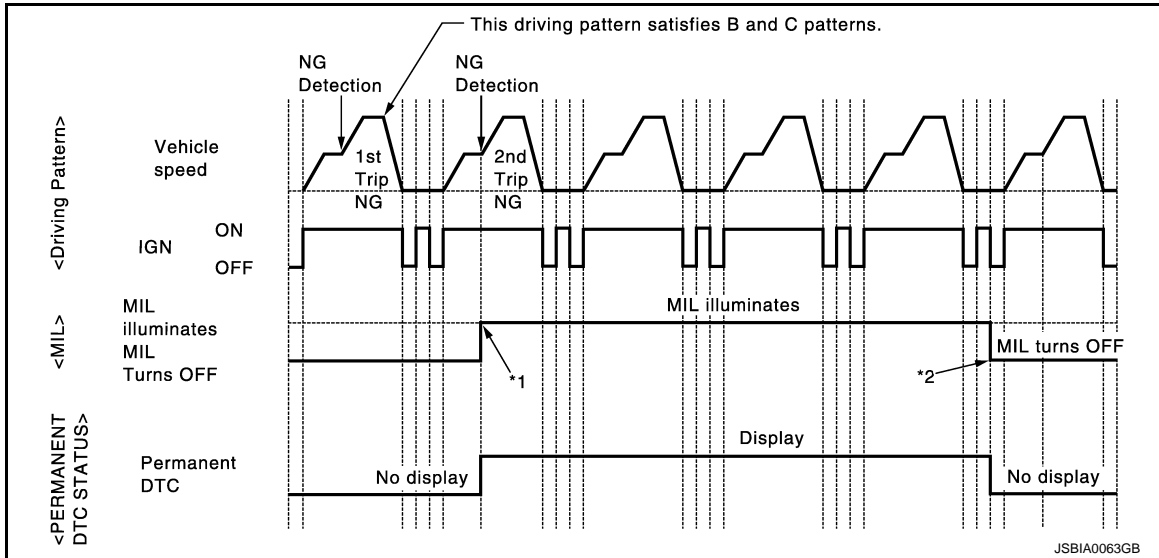

\*1: When the same malfunction is detected in two consecutive trips, MIL will illuminate.

\*2: MIL will turn off after vehicle is driven 3 times (pattern B) without any malfunctions.

When a DTC is not stored in ECM

The erasing method depends on a permanent DTC stored in ECM. Refer to the following table.

**NOTE:**

If the applicable permanent DTC includes multiple groups, perform the procedure of Group B first. If the permanent DTC is not erased, perform the procedure of Group A.

×: Applicable —: Not applicable

| Group* | Perform "DTC CONFIRMATION PROCEDURE" for applicable DTCs. | Driving pattern |   |
|--------|---|-----------------|---|
|        |   | B               | D |
| A      | ×   | —               | — |
| B      | —   | ×               | × |

\*: For group, refer to [EC-117. "DTC Index"](#).

Permanent DTC item

For permanent DTC items, MIL turns ON. Refer to [EC-117. "DTC Index"](#).

# HOW TO ERASE PERMANENT DTC

< BASIC INSPECTION >

[VQ37VHR FOR USA AND CANADA]

## Permanent DTC service procedure

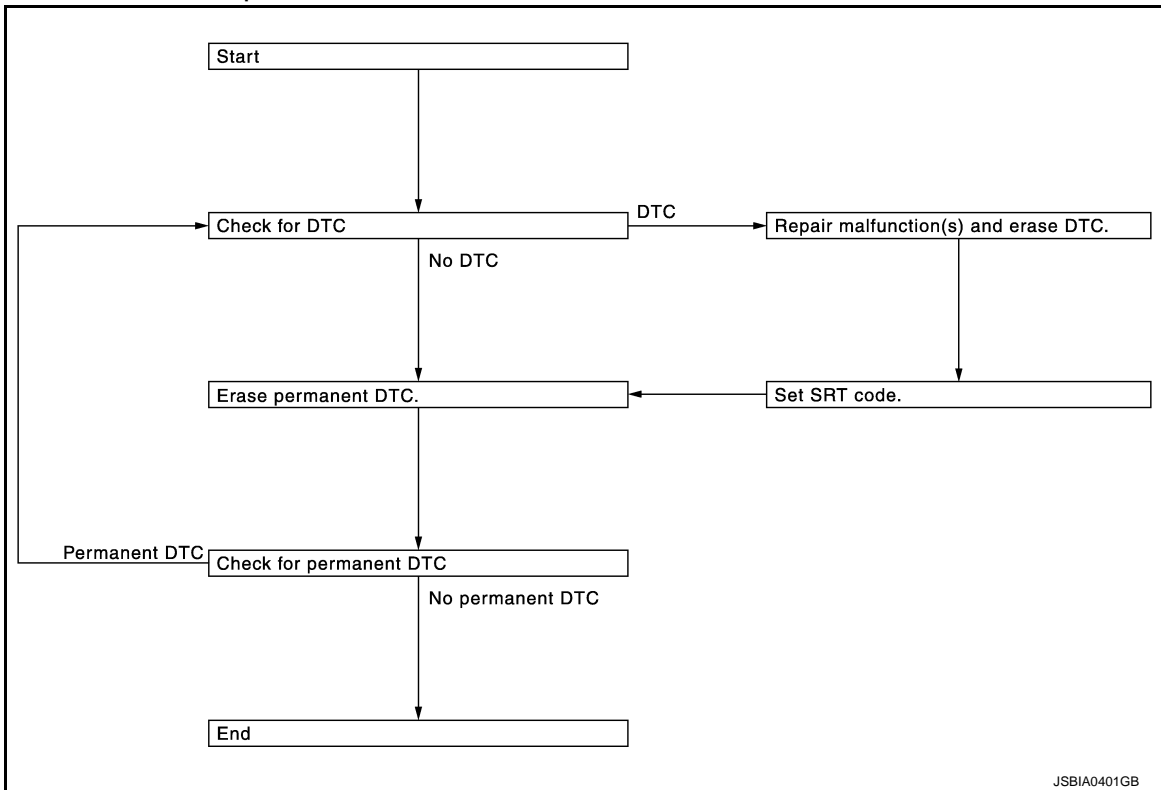

## Work Procedure (Group A)

INFOID:000000007202318

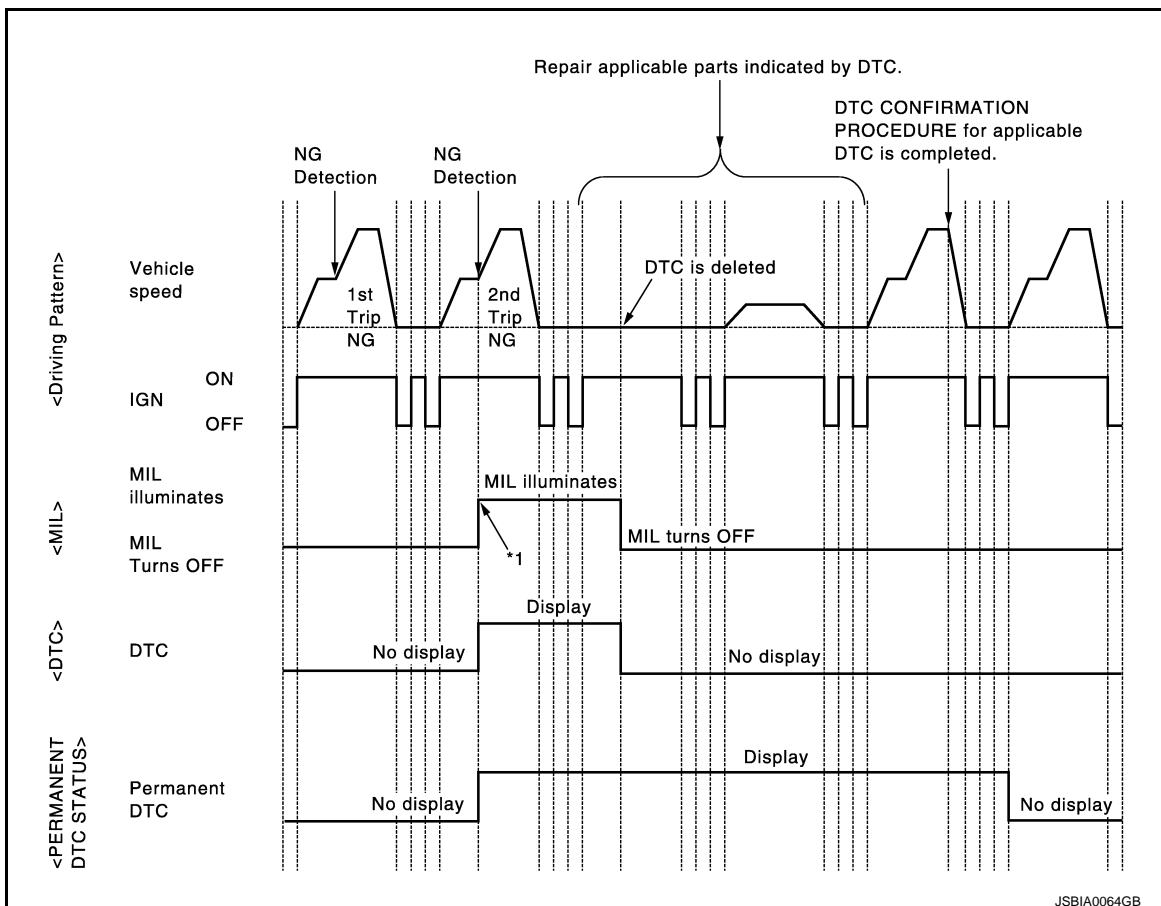

# HOW TO ERASE PERMANENT DTC

[VQ37VHR FOR USA AND CANADA]

< BASIC INSPECTION >

---

\*1: When the same malfunction is detected in two consecutive trips, MIL will illuminate.

## 1. CHECK DTC

---

Check DTC.

Is any DTC detected?

YES >> Repair malfunction(s) and erase DTC. Refer to [EC-85. "On Board Diagnosis Function"](#), [EC-88. "CONSULT Function"](#).

NO >> GO TO 2.

## 2. CHECK PERMANENT DTC

---

 With CONSULT

1. Turn ignition switch OFF and wait at least 10 seconds.
2. Turn ignition switch ON.
3. Turn ignition switch OFF and wait at least 10 seconds.
4. Turn ignition switch ON.
5. Select "PERMANENT DTC STATUS" mode with CONSULT.

 With GST

1. Turn ignition switch OFF and wait at least 10 seconds.
2. Turn ignition switch ON.
3. Turn ignition switch OFF and wait at least 10 seconds.
4. Turn ignition switch ON.
5. Select Service \$0A with GST.

Is any permanent DTC detected?

YES >> GO TO 3.

NO >> END

## 3. PERFORM DTC CONFIRMATION PROCEDURE

---

Perform "DTC CONFIRMATION PROCEDURE" for DTCs which are the same as permanent DTCs stored in ECM. Refer to [EC-117. "DTC Index"](#).

>> GO TO 4.

## 4. CHECK PERMANENT DTC

---

 With CONSULT

1. Turn ignition switch OFF and wait at least 10 seconds.
2. Turn ignition switch ON.
3. Turn ignition switch OFF and wait at least 10 seconds.
4. Turn ignition switch ON.
5. Select "PERMANENT DTC STATUS" mode with CONSULT.

 With GST

1. Turn ignition switch OFF and wait at least 10 seconds.
2. Turn ignition switch ON.
3. Turn ignition switch OFF and wait at least 10 seconds.
4. Turn ignition switch ON.
5. Select Service \$0A with GST.

Is any permanent DTC detected?

YES >> GO TO 1.

NO >> END



# HOW TO ERASE PERMANENT DTC

< BASIC INSPECTION >

[VQ37VHR FOR USA AND CANADA]

## Work Procedure (Group B)

INFOID:000000007202319

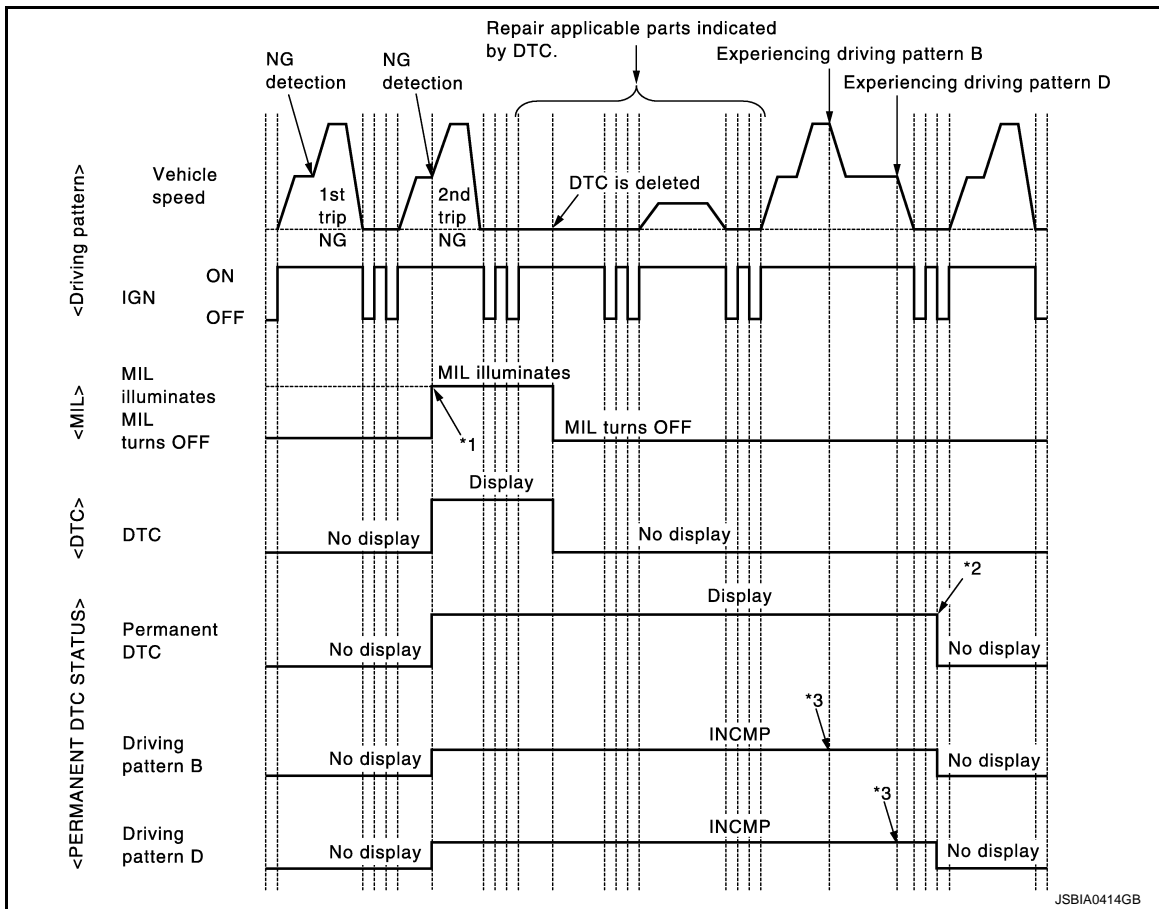

\*1: When the same malfunction is detected in two consecutive trips, MIL will illuminate.

\*2: After experiencing driving pattern B and D, permanent DTC is erased.

\*3: Indication does not change unless the ignition switch is turned from ON to OFF twice even after experiencing driving pattern B or D.

### NOTE:

Drive the vehicle according to only driving patterns indicating "INCMP" in driving patterns B and D on the "PERMANENT DTC STATUS" screen.

## 1. CHECK DTC

Check DTC.

Is any DTC detected?

YES >> Repair malfunction(s) and erase DTC. Refer to [EC-85. "On Board Diagnosis Function"](#), [EC-88. "CONSULT Function"](#).

NO >> GO TO 2.

## 2. CHECK PERMANENT DTC

With CONSULT

1. Turn ignition switch OFF and wait at least 10 seconds.
2. Turn ignition switch ON.
3. Turn ignition switch OFF and wait at least 10 seconds.
4. Turn ignition switch ON.
5. Select "PERMANENT DTC STATUS" mode with CONSULT.

With GST

1. Turn ignition switch OFF and wait at least 10 seconds.
2. Turn ignition switch ON.
3. Turn ignition switch OFF and wait at least 10 seconds.

## HOW TO ERASE PERMANENT DTC

[VQ37VHR FOR USA AND CANADA]

< BASIC INSPECTION >

4. Turn ignition switch ON.
5. Select Service \$0A with GST.

Is any permanent DTC detected?

- YES >> GO TO 3.  
NO >> END

### 3.DRIVE DRIVING PATTERN B

#### CAUTION:

- Always drive at a safe speed.
- Never erase self-diagnosis results.
- If self-diagnosis results are erased during the trip of driving pattern B or D, the counter of driving pattern B and D is reset.

Ⓟ With CONSULT

1. Start engine and warm it up to normal operating temperature.
2. Use "PERMANENT DTC WORK SUPPORT" mode with CONSULT to drive the vehicle according to driving pattern B. Refer to [EC-88. "CONSULT Function"](#), [EC-82. "DIAGNOSIS DESCRIPTION : Driving Pattern"](#).

Ⓢ With GST

1. Start engine and warm it up to normal operating temperature.
2. Drive the vehicle according to driving pattern B. Refer to [EC-82. "DIAGNOSIS DESCRIPTION : Driving Pattern"](#).

>> GO TO 4.

### 4.CHECK PERMANENT DTC

Ⓟ With CONSULT

1. Turn ignition switch OFF and wait at least 10 seconds.
2. Turn ignition switch ON.
3. Turn ignition switch OFF and wait at least 10 seconds.
4. Turn ignition switch ON.
5. Select "PERMANENT DTC STATUS" mode with CONSULT.

Ⓢ With GST

1. Turn ignition switch OFF and wait at least 10 seconds.
2. Turn ignition switch ON.
3. Turn ignition switch OFF and wait at least 10 seconds.
4. Turn ignition switch ON.
5. Select Service \$0A with GST.

Is any permanent DTC detected?

- YES >> GO TO 5.  
NO >> END

### 5.DRIVE DRIVING PATTERN D

#### CAUTION:

- Always drive at a safe speed.
- Never erase self-diagnosis results.
- If self-diagnosis results are erased during the trip of driving pattern B or D, the counter of driving pattern B and D is reset.

1. Drive the vehicle according to driving pattern D. Refer to [EC-82. "DIAGNOSIS DESCRIPTION : Driving Pattern"](#).

>> GO TO 6.

### 6.CHECK PERMANENT DTC

Ⓟ With CONSULT

1. Turn ignition switch OFF and wait at least 10 seconds.
2. Turn ignition switch ON.
3. Turn ignition switch OFF and wait at least 10 seconds.
4. Turn ignition switch ON.

# HOW TO ERASE PERMANENT DTC

[VQ37VHR FOR USA AND CANADA]

< BASIC INSPECTION >

5. Select "PERMANENT DTC STATUS" mode with CONSULT.

 With GST

1. Turn ignition switch OFF and wait at least 10 seconds.
2. Turn ignition switch ON.
3. Turn ignition switch OFF and wait at least 10 seconds.
4. Turn ignition switch ON.
5. Select Service \$0A with GST.

Is any permanent DTC detected?

YES >> GO TO 1.

NO >> END

A

EC

C

D

E

F

G

H

I

J

K

L

M

N

O

P

## DTC/CIRCUIT DIAGNOSIS

### TROUBLE DIAGNOSIS - SPECIFICATION VALUE

#### Description

INFOID:000000006882850

The specification (SP) value indicates the tolerance of the value that is displayed in "SPEC" in "DATA MONITOR" mode of CONSULT during normal operation of the Engine Control System. When the value in "SPEC" in "DATA MONITOR" mode is within the SP value, the Engine Control System is confirmed OK. When the value in "SPEC" in "DATA MONITOR" mode is NOT within the SP value, the Engine Control System may have one or more malfunctions.

The SP value is used to detect malfunctions that may affect the Engine Control System, but will not illuminate the MIL.

The SP value will be displayed for the following three items:

- B/FUEL SCHDL (The fuel injection pulse width programmed into ECM prior to any learned on board correction)
- A/F ALPHA-B1/B2 (The mean value of air-fuel ratio feedback correction factor per cycle)
- MAS A/F SE-B1/B2 (The signal voltage of the mass air flow sensor)

#### Component Function Check

INFOID:000000006882851

### 1. PRECONDITIONING

Make sure that all of the following conditions are satisfied.

#### TESTING CONDITION

- Vehicle driven distance: More than 5,000 km (3,107 miles)
- Barometric pressure: 98.3 - 104.3 kPa (1.003 - 1.064 kg/cm<sup>2</sup>, 14.25 - 15.12 psi)
- Atmospheric temperature: 20 - 30°C (68 - 86°F)
- Engine coolant temperature: 75 - 95°C (167 - 203°F)
- Transmission: Warmed-up
- After the engine is warmed up to normal operating temperature, drive vehicle until "ATF TEMP 1" (A/T fluid temperature sensor signal) indicates more than 60°C (140°F).
- Electrical load: Not applied
  - Rear window defogger switch, air conditioner switch, lighting switch are OFF. Steering wheel is straight ahead.
- Engine speed: Idle

>> GO TO 2.

### 2. PERFORM SPEC IN DATA MONITOR MODE

#### Ⓜ With CONSULT

#### NOTE:

Perform "SPEC" in "DATA MONITOR" mode in maximum scale display.

1. Perform [EC-154. "Work Procedure"](#).
2. Select "B/FUEL SCHDL", "A/F ALPHA-B1", "A/F ALPHA-B2", "MAS A/F SE-B1" and "MAS A/F SE-B2" in "SPEC" of "DATA MONITOR" mode with CONSULT.
3. Make sure that monitor items are within the SP value.

Is the measurement value within the SP value?

- YES >> INSPECTION END  
 NO >> Go to [EC-173. "Diagnosis Procedure"](#).

# TROUBLE DIAGNOSIS - SPECIFICATION VALUE

< DTC/CIRCUIT DIAGNOSIS >

[VQ37VHR FOR USA AND CANADA]

## Diagnosis Procedure

INFOID:000000006882852

### OVERALL SEQUENCE

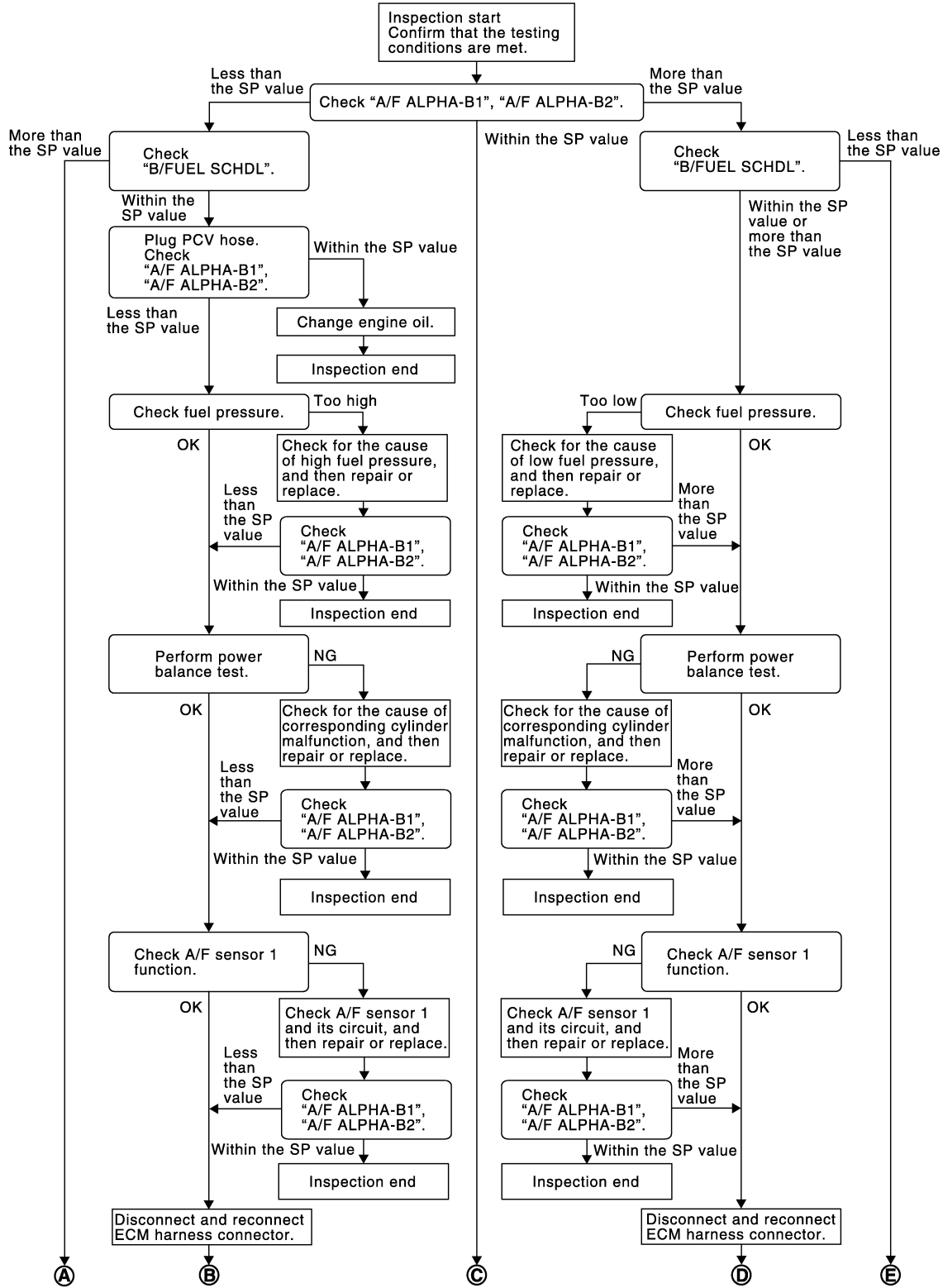

JMBIA1468GB

A  
EC  
C  
D  
E  
F  
G  
H  
I  
J  
K  
L  
M  
N  
O  
P

# TROUBLE DIAGNOSIS - SPECIFICATION VALUE

< DTC/CIRCUIT DIAGNOSIS >

[VQ37VHR FOR USA AND CANADA]

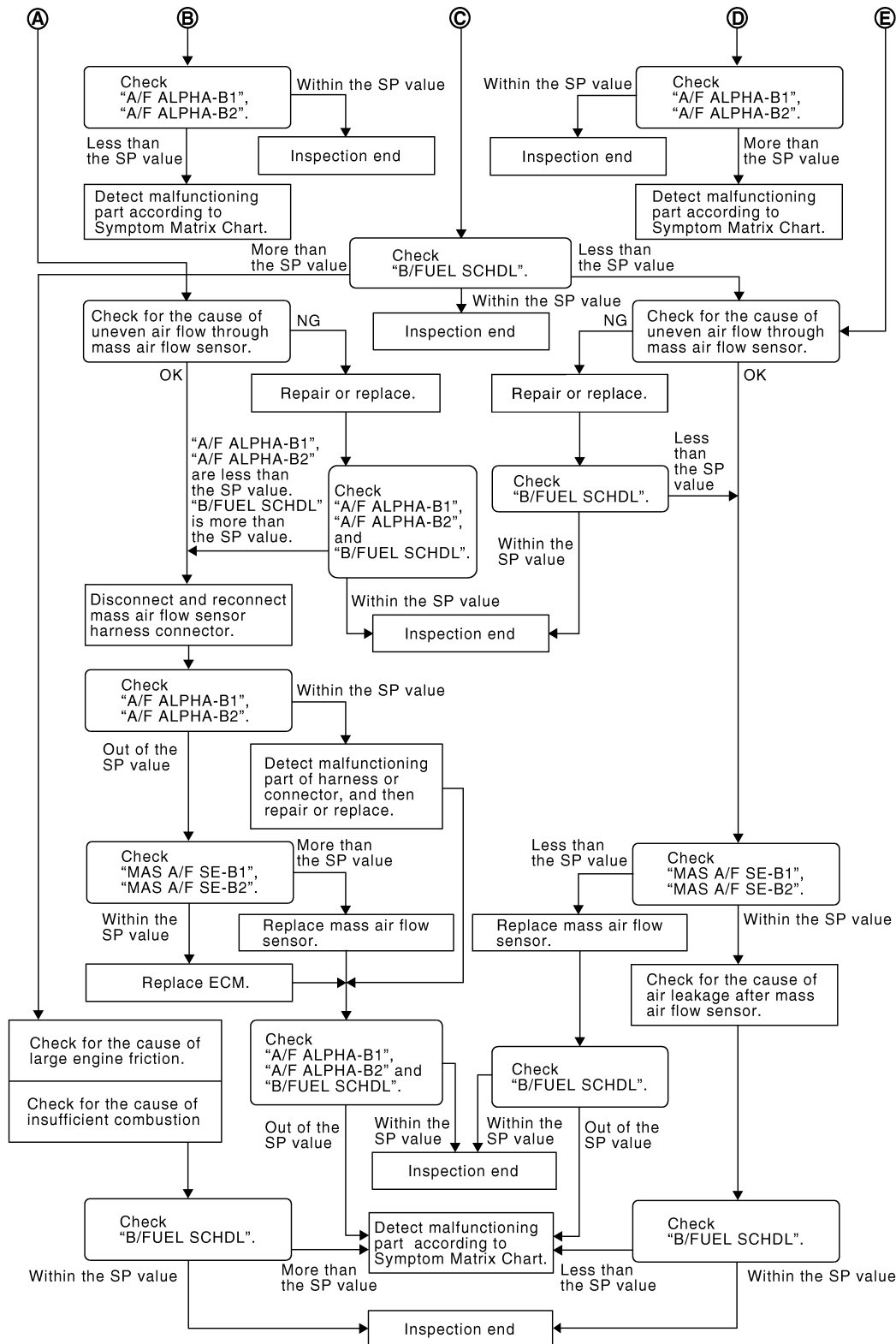

JMBIA0056GB

## DETAILED PROCEDURE

### 1. CHECK "A/F ALPHA-B1", "A/F ALPHA-B2"

#### ⓑ With CONSULT

1. Start engine.
2. Confirm that the testing conditions are met. Refer to [EC-172, "Component Function Check"](#).
3. Select "A/F ALPHA-B1", "A/F ALPHA-B2" in "SPEC" of "DATA MONITOR" mode, and make sure that each indication is within the SP value.

# TROUBLE DIAGNOSIS - SPECIFICATION VALUE

< DTC/CIRCUIT DIAGNOSIS >

[VQ37VHR FOR USA AND CANADA]

## NOTE:

Check "A/F ALPHA-B1", "A/F ALPHA-B2" for approximately 1 minute because they may fluctuate. It is NG if the indication is out of the SP value even a little.

Is the measurement value within the SP value?

YES >> GO TO 17.

NO-1 >> Less than the SP value: GO TO 2.

NO-2 >> More than the SP value: GO TO 3.

## 2.CHECK "B/FUEL SCHDL"

Select "B/FUEL SCHDL" in "SPEC" of "DATA MONITOR" mode, and make sure that the indication is within the SP value.

Is the measurement value within the SP value?

YES >> GO TO 4.

NO >> More than the SP value: GO TO 19.

## 3.CHECK "B/FUEL SCHDL"

Select "B/FUEL SCHDL" in "SPEC" of "DATA MONITOR" mode, and make sure that the indication is within the SP value.

Is the measurement value within the SP value?

YES >> GO TO 6.

NO-1 >> More than the SP value: GO TO 6.

NO-2 >> Less than the SP value: GO TO 25.

## 4.CHECK "A/F ALPHA-B1", "A/F ALPHA-B2"

1. Stop the engine.

2. Disconnect PCV hose, and then plug it.

3. Start engine.

4. Select "A/F ALPHA-B1", "A/F ALPHA-B2" in "SPEC" of "DATA MONITOR" mode, and make sure that each indication is within the SP value.

Is the measurement value within the SP value?

YES >> GO TO 5.

NO >> GO TO 6.

## 5.CHANGE ENGINE OIL

1. Stop the engine.

2. Change engine oil.

## NOTE:

This symptom may occur when a large amount of gasoline is mixed with engine oil because of driving conditions (such as when engine oil temperature does not rise enough since a journey distance is too short during winter). The symptom will not be detected after changing engine oil or changing driving conditions.

>> INSPECTION END

## 6.CHECK FUEL PRESSURE

Check fuel pressure. (Refer to [EC-158, "Work Procedure"](#).)

Is the inspection result normal?

YES >> GO TO 9.

NO-1 >> Fuel pressure is too high: Replace "fuel filter and fuel pump assembly" and then GO TO 8.

NO-2 >> Fuel pressure is too low: GO TO 7.

## 7.DETECT MALFUNCTIONING PART

Check fuel hoses and fuel tubes for clogging.

Is the inspection result normal?

YES >> Replace "fuel filter and fuel pump assembly" and then GO TO 8.

NO >> Repair or replace and then GO TO 8.

## 8.CHECK "A/F ALPHA-B1", "A/F ALPHA-B2"

## TROUBLE DIAGNOSIS - SPECIFICATION VALUE

[VQ37VHR FOR USA AND CANADA]

< DTC/CIRCUIT DIAGNOSIS >

1. Start engine.
2. Select "A/F ALPHA-B1", "A/F ALPHA-B2" in "SPEC" of "DATA MONITOR" mode, and make sure that each indication is within the SP value.

Is the measurement value within the SP value?

- YES >> INSPECTION END  
NO >> GO TO 9.

### 9.PERFORM POWER BALANCE TEST

1. Perform "POWER BALANCE" in "ACTIVE TEST" mode.
2. Make sure that the each cylinder produces a momentary engine speed drop.

Is the inspection result normal?

- YES >> GO TO 12.  
NO >> GO TO 10.

### 10.DETECT MALFUNCTIONING PART

Check the following bellow.

- Ignition coil and its circuit (Refer to [EC-519, "Component Function Check".](#))
- Fuel injector and its circuit (Refer to [EC-512, "Component Function Check".](#))
- Intake air leakage
- Low compression pressure (Refer to [EM-18, "Inspection".](#))

Is the inspection result normal?

- YES >> Replace fuel injector and then GO TO 11.  
NO >> Repair or replace malfunctioning part and then GO TO 11.

### 11.CHECK "A/F ALPHA-B1", "A/F ALPHA-B2"

1. Start engine.
2. Select "A/F ALPHA-B1", "A/F ALPHA-B2" in "SPEC" of "DATA MONITOR" mode, and make sure that each indication is within the SP value.

Is the measurement value within the SP value?

- YES >> INSPECTION END  
NO >> GO TO 12.

### 12.CHECK A/F SENSOR 1 FUNCTION

Perform all DTC CONFIRMATION PROCEDURE related with A/F sensor 1.

- For DTC P0130, P0150, refer to [EC-243, "DTC Logic".](#)
- For DTC P0131, P0151, refer to [EC-247, "DTC Logic".](#)
- For DTC P0132, P0152, refer to [EC-250, "DTC Logic".](#)
- For DTC P0133, P0153, refer to [EC-253, "DTC Logic".](#)
- For DTC P2A00, P2A03, refer to [EC-499, "DTC Logic".](#)

Are any DTCs detected?

- YES >> GO TO 13.  
NO >> GO TO 15.

### 13.CHECK A/F SENSOR 1 CIRCUIT

Perform Diagnosis Procedure according to corresponding DTC.

>> GO TO 14.

### 14.CHECK "A/F ALPHA-B1", "A/F ALPHA-B2"

1. Start engine.
2. Select "A/F ALPHA-B1", "A/F ALPHA-B2" in "SPEC" of "DATA MONITOR" mode, and make sure that each indication is within the SP value.

Is the measurement value within the SP value?

- YES >> INSPECTION END  
NO >> GO TO 15.

### 15.DISCONNECT AND RECONNECT ECM HARNESS CONNECTOR

1. Stop the engine.



## TROUBLE DIAGNOSIS - SPECIFICATION VALUE

< DTC/CIRCUIT DIAGNOSIS >

[VQ37VHR FOR USA AND CANADA]

2. Disconnect ECM harness connector. Check pin terminal and connector for damage, and then reconnect it.

>> GO TO 16.

### 16.CHECK "A/F ALPHA-B1", "A/F ALPHA-B2"

1. Start engine.
2. Select "A/F ALPHA-B1", "A/F ALPHA-B2" in "SPEC" of "DATA MONITOR" mode, and make sure that each indication is within the SP value.

Is the measurement value within the SP value?

YES >> INSPECTION END

NO >> Detect malfunctioning part according to [EC-532. "Symptom Table"](#).

### 17.CHECK "B/FUEL SCHDL"

Select "B/FUEL SCHDL" in "SPEC" of "DATA MONITOR" mode, and make sure that the indication is within the SP value.

Is the measurement value within the SP value?

YES >> INSPECTION END

NO-1 >> More than the SP value: GO TO 18.

NO-2 >> Less than the SP value: GO TO 25.

### 18.DETECT MALFUNCTIONING PART

1. Check for the cause of large engine friction. Refer to the following.
  - Engine oil level is too high
  - Engine oil viscosity
  - Belt tension of power steering, alternator, A/C compressor, etc. is excessive
  - Noise from engine
  - Noise from transmission, etc.
2. Check for the cause of insufficient combustion. Refer to the following.
  - Valve clearance malfunction
  - Intake valve timing control function malfunction
  - Camshaft sprocket installation malfunction, etc.

>> Repair or replace malfunctioning part, and then GO TO 30.

### 19.CHECK INTAKE SYSTEM

Check for the cause of uneven air flow through mass air flow sensor. Refer to the following.

- Crushed air ducts
- Malfunctioning seal of air cleaner element
- Uneven dirt of air cleaner element
- Improper specification of intake air system

Is the inspection result normal?

YES >> GO TO 21.

NO >> Repair or replace malfunctioning part, and then GO TO 20.

### 20.CHECK "A/F ALPHA-B1", "A/F ALPHA-B2", AND "B/FUEL SCHDL"

Select "A/F ALPHA-B1", "A/F ALPHA-B2", and "B/FUEL SCHDL" in "SPEC" of "DATA MONITOR" mode, and make sure that each indication is within the SP value.

Is the measurement value within the SP value?

YES >> INSPECTION END

NO >> "B/FUEL SCHDL" is more, "A/F ALPHA-B1", "A/F ALPHA-B2" are less than the SP value: GO TO 21.

### 21.DISCONNECT AND RECONNECT MASS AIR FLOW SENSOR HARNESS CONNECTOR

1. Stop the engine.
2. Disconnect mass air flow sensor harness connector. Check pin terminal and connector for damage and then reconnect it again.

>> GO TO 22.

## TROUBLE DIAGNOSIS - SPECIFICATION VALUE

< DTC/CIRCUIT DIAGNOSIS >

[VQ37VHR FOR USA AND CANADA]

---

### 22.CHECK "A/F ALPHA-B1", "A/F ALPHA-B2"

---

1. Start engine.
2. Select "A/F ALPHA-B1", "A/F ALPHA-B2" in "SPEC" of "DATA MONITOR" mode, and make sure that each indication is within the SP value.

Is the measurement value within the SP value?

YES >> Detect malfunctioning part of mass air flow sensor circuit and repair it. Refer to [EC-211, "Diagnosis Procedure"](#). Then GO TO 29.

NO >> GO TO 23.

---

### 23.CHECK "MAS A/F SE-B1", "MAS A/F SE-B2"

---

Select "MAS A/F SE-B1", "MAS A/F SE-B2" in "SPEC" of "DATA MONITOR" mode, and make sure that the indication is within the SP value.

Is the measurement value within the SP value?

YES >> GO TO 24.

NO >> More than the SP value: Replace malfunctioning mass air flow sensor, and then GO TO 29.

---

### 24.REPLACE ECM

---

1. Replace ECM.
2. Go to [EC-144, "Work Procedure"](#).

>> GO TO 29.

---

### 25.CHECK INTAKE SYSTEM

---

Check for the cause of uneven air flow through mass air flow sensor. Refer to the following.

- Crushed air ducts
- Malfunctioning seal in air cleaner element
- Uneven dirt in air cleaner element
- Improper specification in intake air system

Is the inspection result normal?

YES >> GO TO 27.

NO >> Repair or replace malfunctioning part, and then GO TO 26.

---

### 26.CHECK "B/FUEL SCHDL"

---

Select "B/FUEL SCHDL" in "SPEC" of "DATA MONITOR" mode, and make sure that the indication is within the SP value.

Is the measurement value within the SP value?

YES >> INSPECTION END

NO >> Less than the SP value: GO TO 27.

---

### 27.CHECK "MAS A/F SE-B1", "MAS A/F SE-B2"

---

Select "MAS A/F SE-B1", "MAS A/F SE-B2" in "SPEC" of "DATA MONITOR" mode, and make sure that each indication is within the SP value.

Is the measurement value within the SP value?

YES >> GO TO 28.

NO >> Less than the SP value: Replace malfunctioning mass air flow sensor, and then GO TO 30.

---

### 28.CHECK INTAKE SYSTEM

---

Check for the cause of air leak after the mass air flow sensor. Refer to the following.

- Disconnection, looseness, and cracks in air duct
- Looseness of oil filler cap
- Disconnection of oil level gauge
- Open stuck, breakage, hose disconnection, or cracks in PCV valve
- Disconnection or cracks in EVAP purge hose, stuck open EVAP canister purge volume control solenoid valve
- Malfunctioning seal in rocker cover gasket
- Disconnection, looseness, or cracks in hoses, such as a vacuum hose, connecting to intake air system parts
- Malfunctioning seal in intake air system, etc.

# TROUBLE DIAGNOSIS - SPECIFICATION VALUE

< DTC/CIRCUIT DIAGNOSIS >

[VQ37VHR FOR USA AND CANADA]

>> GO TO 30.

## 29. CHECK "A/F ALPHA-B1", "A/F ALPHA-B2", AND "B/FUEL SCHDL"

Select "A/F ALPHA-B1", "A/F ALPHA-B2", and "B/FUEL SCHDL" in "SPEC" of "DATA MONITOR" mode, and make sure that each indication is within the SP value.

Is the measurement value within the SP value?

YES >> INSPECTION END

NO >> Detect malfunctioning part according to [EC-532. "Symptom Table"](#).

## 30. CHECK "B/FUEL SCHDL"

Select "B/FUEL SCHDL" in "SPEC" of "DATA MONITOR" mode, and then make sure that the indication is within the SP value.

Is the measurement value within the SP value?

YES >> INSPECTION END

NO >> Detect malfunctioning part according to [EC-532. "Symptom Table"](#).

A  
EC  
C  
D  
E  
F  
G  
H  
I  
J  
K  
L  
M  
N  
O  
P

# POWER SUPPLY AND GROUND CIRCUIT

< DTC/CIRCUIT DIAGNOSIS >

[VQ37VHR FOR USA AND CANADA]

## POWER SUPPLY AND GROUND CIRCUIT

### Diagnosis Procedure

INFOID:00000006882853

#### 1. CHECK GROUND CONNECTION

1. Turn ignition switch OFF.
2. Check ground connection M95. Refer to Ground Inspection in [GI-47, "Circuit Inspection"](#).

Is the inspection result normal?

- YES >> GO TO 2.  
NO >> Repair or replace ground connection.

#### 2. CHECK ECM GROUND CIRCUIT FOR OPEN AND SHORT-I

1. Disconnect ECM harness connector.
2. Check the continuity between ECM harness connector and ground.

| ECM       |          | Ground | Continuity |
|-----------|----------|--------|------------|
| Connector | Terminal |        |            |
| F101      | 8        | Ground | Existed    |
| M107      | 123      |        |            |
|           | 124      |        |            |
|           | 127      |        |            |
|           | 128      |        |            |

3. Also check harness for short to power.

Is the inspection result normal?

- YES >> GO TO 4.  
NO >> GO TO 3.

#### 3. DETECT MALFUNCTIONING PART

Check the following.

- Harness connectors F103, M116
- Harness for open or short between ECM and ground

>> Repair open circuit or short to power in harness or connectors.

#### 4. CHECK ECM POWER SUPPLY CIRCUIT-I

1. Reconnect ECM harness connector.
2. Turn ignition switch ON.
3. Check the voltage between ECM harness connector and ground.

| ECM       |          |           |          | Voltage         |
|-----------|----------|-----------|----------|-----------------|
| +         |          | -         |          |                 |
| Connector | Terminal | Connector | Terminal |                 |
| F102      | 53       | M107      | 128      | Battery voltage |

Is the inspection result normal?

- YES >> GO TO 6.  
NO >> GO TO 5.

#### 5. DETECT MALFUNCTIONING PART

Check the following.

- Harness connectors E20, F40
- IPDM E/R harness connector E7
- 10 A fuse (No. 44)
- Harness for open or short between ECM and fuse

# POWER SUPPLY AND GROUND CIRCUIT

< DTC/CIRCUIT DIAGNOSIS >

[VQ37VHR FOR USA AND CANADA]

>> Repair open circuit, short to ground or short to power in harness or connectors.

## 6. CHECK ECM POWER SUPPLY CIRCUIT-II

1. Turn ignition switch OFF and wait at least 10 seconds.
2. Check the voltage between ECM harness connector terminals as follows.

| ECM       |          |          | Voltage  |
|-----------|----------|----------|--|
| Connector | +        | -        |  |
|           | Terminal | Terminal |  |
| M107      | 125      | 128      | After turning ignition switch OFF, battery voltage will exist for a few seconds, then drop to approximately 0 V. |

Is the inspection result normal?

YES >> GO TO 7.

NO >> GO TO 9.

## 7. CHECK ECM POWER SUPPLY CIRCUIT-III

1. Turn ignition switch ON.
2. Check the voltage between IPDM E/R harness connector and ground.

| IPDM E/R  |          | Ground | Voltage         |
|-----------|----------|--------|-----------------|
| Connector | Terminal |        |                 |
| E5        | 5        | Ground | Battery voltage |

Is the inspection result normal?

YES >> GO TO 8.

NO >> Replace IPDM E/R. Refer to [PCS-33, "Exploded View"](#).

## 8. CHECK INTERMITTENT INCIDENT

Refer to [GI-47, "Circuit Inspection"](#).

>> INSPECTION END

## 9. CHECK ECM POWER SUPPLY CIRCUIT-IV

1. Turn ignition switch OFF and wait at least 10 seconds.
2. Check the voltage between ECM harness connector terminals as follows.

| ECM       |          |           |          | Voltage         |
|-----------|----------|-----------|----------|-----------------|
| +         |          | -         |          |                 |
| Connector | Terminal | Connector | Terminal |                 |
| F101      | 24       | M107      | 128      | Battery voltage |

Is the inspection result normal?

YES >> GO TO 13.

NO >> GO TO 10.

## 10. CHECK ECM POWER SUPPLY CIRCUIT-V

1. Disconnect ECM harness connector.
2. Disconnect IPDM E/R harness connector.
3. Check the continuity between ECM harness connector and IPDM E/R harness connector.

| ECM       |          | IPDM E/R  |          | Continuity |
|-----------|----------|-----------|----------|------------|
| Connector | Terminal | Connector | Terminal |            |
| F101      | 24       | E7        | 70       | Existed    |

4. Also check harness for short to ground and short to power.

# POWER SUPPLY AND GROUND CIRCUIT

[VQ37VHR FOR USA AND CANADA]

< DTC/CIRCUIT DIAGNOSIS >

Is the inspection result normal?

- YES >> GO TO 12.
- NO >> GO TO 11.

## 11.DETECT MALFUNCTIONING PART

Check the following.

- Harness or connectors E20, F40
- Harness for open or short between ECM and IPDM E/R

>> Repair open circuit, short to ground or short to power in harness or connectors.

## 12.CHECK 15 A FUSE

1. Disconnect 15 A fuse (No. 51) from IPDM E/R.
2. Check 15 A fuse.

Is the inspection result normal?

- YES >> GO TO 15.
- NO >> Replace 15 A fuse.

## 13.CHECK ECM POWER SUPPLY CIRCUIT-VI

1. Disconnect ECM harness connector.
2. Disconnect IPDM E/R harness connector.
3. Check the continuity between ECM harness connector and IPDM E/R harness connector.

| ECM       |          | IPDM E/R  |          | Continuity |
|-----------|----------|-----------|----------|------------|
| Connector | Terminal | Connector | Terminal |            |
| M107      | 125      | E5        | 6        | Existed    |

4. Also check harness for short to ground and short to power.

Is the inspection result normal?

- YES >> GO TO 15.
- NO >> GO TO 14.

## 14.DETECT MALFUNCTIONING PART

Check the following.

- Harness or connectors E106, M6
- Harness for open or short between ECM and IPDM E/R

>> Repair open circuit, short to ground or short to power in harness or connectors.

## 15.CHECK INTERMITTENT INCIDENT

Refer to [GI-44. "Intermittent Incident"](#).

Is the inspection result normal?

- YES >> Replace IPDM E/R. Refer to [PCS-33. "Exploded View"](#).
- NO >> Repair open circuit, short to ground or short to power in harness or connectors.

# POWER SUPPLY AND GROUND CIRCUIT (VVEL CONTROL MODULE)

< DTC/CIRCUIT DIAGNOSIS >

[VQ37VHR FOR USA AND CANADA]

## POWER SUPPLY AND GROUND CIRCUIT (VVEL CONTROL MODULE)

### Diagnosis Procedure

INFOID:000000006882854

#### 1. CHECK GROUND CONNECTION

1. Turn ignition switch OFF.
2. Check ground connection M95. Refer to Ground Inspection in [GI-47, "Circuit Inspection"](#).

Is the inspection result normal?

- YES >> GO TO 2.  
NO >> Repair or replace ground connection.

#### 2. CHECK VVEL CONTROL MODULE GROUND CIRCUIT FOR OPEN AND SHORT

1. Disconnect VVEL control module harness connector.
2. Check the continuity between VVEL control module harness connector and ground.

| VVEL control module |          | Ground | Continuity |
|---------------------|----------|--------|------------|
| Connector           | Terminal |        |            |
| E15                 | 14       | Ground | Existed    |

3. Also check harness for short to power.

Is the inspection result normal?

- YES >> GO TO 3.  
NO >> Repair open circuit, short to power in harness connectors.

#### 3. CHECK VVEL CONTROL MODULE POWER SUPPLY CIRCUIT-I

1. Reconnect VVEL control module harness connector.
2. Turn ignition switch ON.
3. Check the voltage between VVEL control module harness connector and ground.

| VVEL control module |          |          | Voltage  |
|---------------------|----------|----------|--|
| Connector           | +        | -        |  |
|                     | Terminal | Terminal |  |
| E15                 | 8        | 14       | After turning ignition switch OFF, battery voltage will exist for a few seconds, then drop to approximately 0 V. |

Is the inspection result normal?

- YES >> GO TO 5.  
NO >> GO TO 4.

#### 4. CHECK VVEL CONTROL MODULE POWER SUPPLY CIRCUIT-II

1. Turn ignition switch OFF and wait at least 10 seconds.
2. Disconnect VVEL control module harness connector.
3. Disconnect IPDM E/R harness connector.
4. Check the continuity between VVEL control module harness connector and IPDM E/R harness connector.

| VVEL control module |          | IPDM E/R  |          | Continuity |
|---------------------|----------|-----------|----------|------------|
| Connector           | Terminal | Connector | Terminal |            |
| E15                 | 8        | E7        | 49       | Existed    |

5. Also check harness for short to ground and short to power.

Is the inspection result normal?

- YES >> [EC-180, "Diagnosis Procedure"](#)  
NO >> Repair open circuit, short to ground or short to power in harness or connectors.

#### 5. CHECK INTERMITTENT INCIDENT

Refer to [GI-44, "Intermittent Incident"](#).

## POWER SUPPLY AND GROUND CIRCUIT (VVEL CONTROL MODULE)

< DTC/CIRCUIT DIAGNOSIS >

[VQ37VHR FOR USA AND CANADA]

---

Is the inspection result normal?

YES >> Replace IPDM E/R. Refer to [PCS-33, "Exploded View"](#).

NO >> Repair open circuit, short to ground or short to power in harness or connectors.



# U0101 CAN COMM CIRCUIT

< DTC/CIRCUIT DIAGNOSIS >

[VQ37VHR FOR USA AND CANADA]

## U0101 CAN COMM CIRCUIT

### Description

INFOID:000000006882855

CAN (Controller Area Network) is a serial communication line for real time application. It is an on-vehicle multiplex communication line with high data communication speed and excellent error detection ability. Many electronic control units are equipped onto a vehicle, and each control unit shares information and links with other control units during operation (not independent). In CAN communication, control units are connected with 2 communication lines (CAN H line, CAN L line) allowing a high rate of information transmission with less wiring. Each control unit transmits/receives data but selectively reads required data only.

### DTC Logic

INFOID:000000006882856

### DTC DETECTION LOGIC

| DTC No. | Trouble diagnosis name      | DTC detecting condition  | Possible cause   |
|---------|-----------------------------|--|--|
| U0101   | Lost communication with TCM | When ECM is not transmitting or receiving CAN communication signal of OBD (emission related diagnosis) with TCM for 2 seconds or more. | <ul style="list-style-type: none"><li>CAN communication line between TCM and ECM (CAN communication line is open or shorted)</li></ul> |

### DTC CONFIRMATION PROCEDURE

#### 1. PERFORM DTC CONFIRMATION PROCEDURE

- Turn ignition switch ON and wait at least 3 seconds.
- Check DTC.

Is DTC detected?

- YES >> [EC-185, "Diagnosis Procedure"](#).  
NO >> INSPECTION END

### Diagnosis Procedure

INFOID:000000006882857

Go to [LAN-25, "Trouble Diagnosis Flow Chart"](#).

# U1001 CAN COMM CIRCUIT

< DTC/CIRCUIT DIAGNOSIS >

[VQ37VHR FOR USA AND CANADA]

## U1001 CAN COMM CIRCUIT

### Description

INFOID:000000006882861

CAN (Controller Area Network) is a serial communication line for real time application. It is an on-vehicle multiplex communication line with high data communication speed and excellent error detection ability. Many electronic control units are equipped onto a vehicle, and each control unit shares information and links with other control units during operation (not independent). In CAN communication, control units are connected with 2 communication lines (CAN H line, CAN L line) allowing a high rate of information transmission with less wiring. Each control unit transmits/receives data but selectively reads required data only.

### DTC Logic

INFOID:000000006882862

### DTC DETECTION LOGIC

| DTC No. | Trouble diagnosis name | DTC detecting condition   | Possible cause  |
|---------|------------------------|---|---|
| U1001   | CAN communication line | When ECM is not transmitting or receiving CAN communication signal other than OBD (emission related diagnosis) for 2 seconds or more. | <ul style="list-style-type: none"><li>Harness or connectors (CAN communication line is open or shorted)</li></ul> |

### DTC CONFIRMATION PROCEDURE

#### 1. PERFORM DTC CONFIRMATION PROCEDURE

1. Turn ignition switch ON and wait at least 3 seconds.
2. Check DTC.

#### Is DTC detected?

- YES >> [EC-186, "Diagnosis Procedure"](#).  
NO >> INSPECTION END

### Diagnosis Procedure

INFOID:000000006882863

Go to [LAN-25, "Trouble Diagnosis Flow Chart"](#).

# U1003 CAN COMM CIRCUIT

< DTC/CIRCUIT DIAGNOSIS >

[VQ37VHR FOR USA AND CANADA]

## U1003 CAN COMM CIRCUIT

### Description

INFOID:000000006882864

CAN (Controller Area Network) is a serial communication line for real time application. It is an on-vehicle multiplex communication line with high data communication speed and excellent error detection ability. ECM and VVEL control module are connected with two communication lines (CAN H line and CAN L line) and transmit/receive data. ECM shares information and links with the VVEL control module during operation.

### DTC Logic

INFOID:000000006882865

#### DTC DETECTION LOGIC

##### NOTE:

If DTC U1003 is displayed with DTC P0607, first perform the trouble diagnosis for DTC P0607. Refer to [EC-387, "DTC Logic"](#).

| DTC No. | Trouble diagnosis name                      | DTC detecting condition   | Possible cause   |
|---------|---|---|--|
| U1003   | Lost communication with VVEL control module | CAN communication signal other than OBD (emission related diagnosis) is not received between VVEL control module and ECM for 2 seconds or more. | <ul style="list-style-type: none"><li>• Harness or connectors (VVEL CAN communication line is open or shorted)</li><li>• ECM</li><li>• VVEL control module</li></ul> |

#### DTC CONFIRMATION PROCEDURE

##### 1. PRECONDITIONING

##### TESTING CONDITION:

Before performing the following procedure, confirm that battery voltage is more than 10 V at idle.

>> GO TO 2.

##### 2. PERFORM DTC CONFIRMATION PROCEDURE

1. Turn ignition switch ON and wait at least 3 seconds.
2. Check DTC.

Is DTC detected?

YES >> Go to [EC-187, "Diagnosis Procedure"](#).

NO >> INSPECTION END

#### Diagnosis Procedure

INFOID:000000006882866

##### 1. CHECK VVEL CAN COMMUNICATION CIRCUIT

1. Turn ignition switch OFF.
2. Disconnect ECM harness connector.
3. Disconnect VVEL control module harness connector.
4. Check the continuity between ECM harness connector and VVEL control module harness connector.

| ECM       |          | VVEL control module |          | Continuity |
|-----------|----------|---------------------|----------|------------|
| Connector | Terminal | Connector           | Terminal |            |
| F102      | 54       | E15                 | 24       | Existed    |
|           | 55       |                     | 11       |            |

5. Also check harness for short to ground and power.

Is the inspection result normal?

YES >> GO TO 3.

NO >> GO TO 2.

##### 2. DETECT MALFUNCTIONING PART

Check the following.

- Harness connector E20, F40

# U1003 CAN COMM CIRCUIT

[VQ37VHR FOR USA AND CANADA]

< DTC/CIRCUIT DIAGNOSIS >

- Harness for open or short between ECM and VVEL control module

>> Repair open circuit or short to ground or short to power in harness or connectors.

## 3. CHECK INTERMITTENT INCIDENT

---

Refer to [GI-44, "Intermittent Incident"](#).

Is the inspection result normal?

YES >> GO TO 4.

NO >> Repair or replace.

## 4. REPLACE VVEL CONTROL MODULE

---

1. Replace VVEL control module.
2. Go to [EC-145, "Work Procedure"](#).

>> GO TO 5.

## 5. PERFORM DTC CONFIRMATION PROCEDURE

---

1. Reconnect all harness connectors disconnected.
2. Turn ignition switch ON.
3. Erase DTC.
4. Perform DTC Confirmation Procedure.  
See [EC-187, "DTC Logic"](#).
5. Check DTC.

Is the DTC U1003 displayed again?

YES >> GO TO 6.

NO >> INSPECTION END

## 6. REPLACE ECM

---

1. Replace ECM.
2. Go to [EC-144, "Work Procedure"](#).

>> INSPECTION END

# U1024 CAN COMM CIRCUIT

< DTC/CIRCUIT DIAGNOSIS >

[VQ37VHR FOR USA AND CANADA]

## U1024 CAN COMM CIRCUIT

### Description

INFOID:000000006882867

CAN (Controller Area Network) is a serial communication line for real time application. It is an on-vehicle multiplex communication line with high data communication speed and excellent error detection ability. ECM and VVEL control module are connected with two communication lines (CAN H line and CAN L line) and transmit/receive data. ECM shares information and links with the VVEL control module during operation.

### DTC Logic

INFOID:000000006882868

#### DTC DETECTION LOGIC

##### NOTE:

If DTC U1024 is displayed with DTC P0607, first perform the trouble diagnosis for DTC P0607.

Refer to [EC-387, "DTC Logic"](#).

| DTC No. | Trouble diagnosis name | DTC detecting condition   | Possible cause  |
|---------|------------------------|---|---|
| U1024   | VVEL CAN communication | <ul style="list-style-type: none"><li>When VVEL control module cannot transmit/receive can communication signal from ECM.</li><li>When detecting error during the initial diagnosis of CAN controller of VVEL control module.</li></ul> | <ul style="list-style-type: none"><li>Harness or connectors (CAN communication line is open or shorted)</li><li>ECM</li><li>VVEL control module</li></ul> |

#### DTC CONFIRMATION PROCEDURE

##### 1. PRECONDITIONING

##### TESTING CONDITION:

Before performing the following procedure, confirm that battery voltage is more than 10 V at idle.

>> GO TO 2.

##### 2. PERFORM DTC CONFIRMATION PROCEDURE

- Turn ignition switch ON and wait at least 3 seconds.
- Check DTC.

##### Is DTC detected?

- YES >> Go to [EC-189, "Diagnosis Procedure"](#).  
NO >> INSPECTION END

### Diagnosis Procedure

INFOID:000000006882869

##### 1. CHECK VVEL CAN COMMUNICATION CIRCUIT

- Turn ignition switch OFF.
- Disconnect ECM harness connector.
- Disconnect VVEL control module harness connector.
- Check the continuity between ECM harness connector and VVEL control module harness connector.

| ECM       |          | VVEL control module |          | Continuity |
|-----------|----------|---------------------|----------|------------|
| Connector | Terminal | Connector           | Terminal |            |
| F102      | 54       | E15                 | 24       | Existed    |
|           | 55       |                     | 11       |            |

- Also check harness for short to ground and power.

##### Is the inspection result normal?

- YES >> GO TO 3.  
NO >> GO TO 2.

##### 2. DETECT MALFUNCTIONING PART

# U1024 CAN COMM CIRCUIT

[VQ37VHR FOR USA AND CANADA]

< DTC/CIRCUIT DIAGNOSIS >

Check the following.

- Harness connector E20, F40
- Harness for open or short between ECM and VVEL control module

>> Harness for open or short between ECM and VVEL control module

## 3. CHECK INTERMITTENT INCIDENT

---

Refer to [GI-44, "Intermittent Incident"](#).

Is the inspection result normal?

YES >> GO TO 4.

NO >> Repair or replace.

## 4. REPLACE VVEL CONTROL MODULE

---

1. Replace VVEL control module.
2. Go to [EC-145, "Work Procedure"](#).

>> GO TO 5.

## 5. PERFORM DTC CONFIRMATION PROCEDURE

---

1. Reconnect all harness connectors disconnected.
2. Turn ignition switch ON.
3. Erase DTC.
4. Perform DTC Confirmation Procedure.  
See [EC-189, "DTC Logic"](#).

Is the DTC U1024 displayed again?

YES >> GO TO 6.

NO >> INSPECTION END

## 6. REPLACE ECM

---

1. Replace ECM.
2. Go to [EC-144, "Work Procedure"](#).

>> INSPECTION END

# P0011, P0021 IVT CONTROL

< DTC/CIRCUIT DIAGNOSIS >

[VQ37VHR FOR USA AND CANADA]

## P0011, P0021 IVT CONTROL

### DTC Logic

INFOID:000000006882870

### DTC DETECTION LOGIC

#### NOTE:

- If DTC P0011 or P0021 is displayed with DTC P0075 or P0081, first perform the trouble diagnosis for DTC P0075, P0081. Refer to [EC-208, "DTC Logic"](#).
- If DTC P0011 or P0021 is displayed with DTC P0524, first perform the trouble diagnosis for DTC P0524. Refer to [EC-378, "DTC Logic"](#).

| DTC No. | Trouble diagnosis name                           | Detecting condition  | Possible cause   |
|---------|--|--|--|
| P0011   | Intake valve timing control performance (bank 1) | There is a gap between angle of target and phase-control angle degree. | <ul style="list-style-type: none"><li>• Crankshaft position sensor (POS)</li><li>• Camshaft position sensor (PHASE)</li><li>• Intake valve control solenoid valve</li><li>• Accumulation of debris to the signal pick-up portion of the camshaft</li><li>• Timing chain installation</li><li>• Foreign matter caught in the oil groove for intake valve timing control</li></ul> |
| P0021   | Intake valve timing control performance (bank 2) |  |  |

### DTC CONFIRMATION PROCEDURE

#### 1. PRECONDITIONING

If DTC Confirmation Procedure has been previously conducted, always perform the following procedure before conducting the next test.

1. Turn ignition switch OFF and wait at least 10 seconds.
2. Turn ignition switch ON.
3. Turn ignition switch OFF and wait at least 10 seconds.

#### TESTING CONDITION:

Before performing the following procedure, confirm that battery voltage is between 10 V and 16 V at idle.

>> GO TO 2.

#### 2. PERFORM DTC CONFIRMATION PROCEDURE-I

1. Turn ignition switch ON and select "DATA MONITOR" mode with CONSULT.
2. Start engine and warm it up to the normal operating temperature.
3. Maintain the following conditions for at least 6 consecutive seconds. Hold the accelerator pedal as steady as possible.

|                |                        |
|----------------|------------------------|
| ENG SPEED      | 525 - 2,000 rpm        |
| COOLAN TEMP/S  | More than 60°C (140°F) |
| Selector lever | P or N position        |

4. Let engine idle for 10 seconds.
5. Check 1st trip DTC.

Is 1st trip DTC detected?

YES >> Go to [EC-192, "Diagnosis Procedure"](#)

NO >> GO TO 3.

#### 3. PERFORM DTC CONFIRMATION PROCEDURE-II

1. Select "DATA MONITOR" mode with CONSULT.
2. Maintain the following conditions for at least 20 consecutive seconds.

|               |  |
|---------------|--|
| ENG SPEED     | 1,700 - 3,175 rpm (A constant rotation is maintained.) |
| COOLAN TEMP/S | More than 70°C (158°F)                                 |

# P0011, P0021 IVT CONTROL

[VQ37VHR FOR USA AND CANADA]

< DTC/CIRCUIT DIAGNOSIS >

|                  |   |
|------------------|---|
| Selector lever   | 1st or 2nd position   |
| Driving location | Driving vehicle uphill<br>(Increased engine load will help maintain the driving conditions required for this test.) |

## CAUTION:

**Always drive at a safe speed.**

3. Check 1st trip DTC.

Is 1st trip DTC detected?

YES >> Go to [EC-192, "Diagnosis Procedure"](#)

NO >> INSPECTION END

## Diagnosis Procedure

INFOID:000000006882871

### 1. CHECK OIL PRESSURE WARNING LAMP

1. Start engine.
2. Check oil pressure warning lamp and confirm it is not illuminated.

Is oil pressure warning lamp illuminated?

YES >> Go to [LU-7, "Inspection"](#).

NO >> GO TO 2.

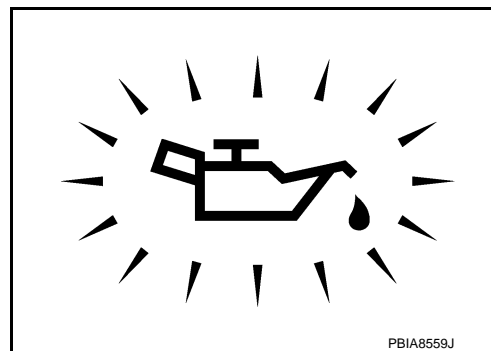

### 2. CHECK INTAKE VALVE TIMING CONTROL SOLENOID VALVE

Refer to [EC-193, "Component Inspection"](#).

Is the inspection result normal?

YES >> GO TO 3.

NO >> Replace malfunctioning intake valve timing control solenoid valve. Refer to [EM-52, "Exploded View"](#).

### 3. CHECK CRANKSHAFT POSITION SENSOR (POS)

Refer to [EC-314, "Component Inspection"](#).

Is the inspection result normal?

YES >> GO TO 4.

NO >> Replace crankshaft position sensor (POS). Refer to [EM-123, "Exploded View"](#).

### 4. CHECK CAMSHAFT POSITION SENSOR (PHASE)

Refer to [EC-319, "Component Inspection"](#).

Is the inspection result normal?

YES >> GO TO 5.

NO >> Replace malfunctioning camshaft position sensor (PHASE). Refer to [EM-52, "Exploded View"](#).

### 5. CHECK CAMSHAFT (INTAKE)

Check the following.



# P0011, P0021 IVT CONTROL

[VQ37VHR FOR USA AND CANADA]

## < DTC/CIRCUIT DIAGNOSIS >

- Accumulation of debris on the signal plate of camshaft front end
- Chipping signal plate of camshaft front end

Is the inspection result normal?

YES >> GO TO 6.

NO >> Remove debris and clean the signal plate of camshaft front end or replace camshaft. Refer to [EM-96, "Exploded View"](#).

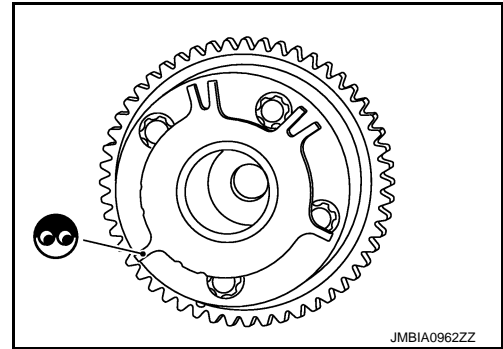

## 6. CHECK TIMING CHAIN INSTALLATION

Check service records for any recent repairs that may cause timing chain misaligned.

Are there any service records that may cause timing chain misaligned?

YES >> Check timing chain installation. Refer to [EM-53, "Removal and Installation"](#).

NO >> GO TO 7.

## 7. CHECK LUBRICATION CIRCUIT

Perform "Inspection of Camshaft Sprocket (INT) Oil Groove". Refer to [EM-106, "Inspection"](#).

Is the inspection result normal?

YES >> GO TO 8.

NO >> Clean lubrication line.

## 8. CHECK INTERMITTENT INCIDENT

Refer to [GI-44, "Intermittent Incident"](#).

>> INSPECTION END

## Component Inspection

INFOID:000000006882872

## 1. CHECK INTAKE VALVE TIMING CONTROL SOLENOID VALVE-I

1. Turn ignition switch OFF.
2. Disconnect intake valve timing control solenoid valve harness connector.
3. Check resistance between intake valve timing control solenoid valve terminals as follows.

| Terminals         | Resistance ( $\Omega$ )                   |
|-------------------|---|
| 1 and 2           | 7.0 - 7.7 [at 20°C (68°F)]                |
| 1 or 2 and ground | $\infty$<br>(Continuity should not exist) |

Is the inspection result normal?

YES >> GO TO 2.

NO >> Replace malfunctioning intake valve timing control solenoid valve. Refer to [EM-52, "Exploded View"](#).

## 2. CHECK INTAKE VALVE TIMING CONTROL SOLENOID VALVE-II

1. Remove intake valve timing control solenoid valve.

## P0011, P0021 IVT CONTROL

[VQ37VHR FOR USA AND CANADA]

< DTC/CIRCUIT DIAGNOSIS >

2. Provide 12 V DC between intake valve timing control solenoid valve terminals 1 and 2, and then interrupt it. Make sure that the plunger moves as shown in the figure.

**CAUTION:**

**Do not apply 12 V DC continuously for 5 seconds or more. Doing so may result in damage to the coil in intake valve timing control solenoid valve.**

**NOTE:**

**Always replace O-ring when intake valve timing control solenoid valve is removed.**

Is the inspection result normal?

YES >> INSPECTION END

NO >> Replace malfunctioning intake valve timing control solenoid valve. Refer to [EM-52. "Exploded View"](#).

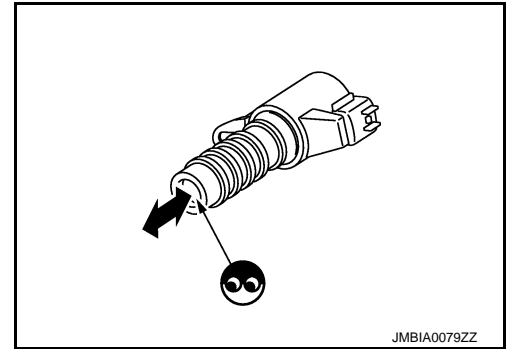

# P0031, P0032, P0051, P0052 A/F SENSOR 1 HEATER

< DTC/CIRCUIT DIAGNOSIS >

[VQ37VHR FOR USA AND CANADA]

## P0031, P0032, P0051, P0052 A/F SENSOR 1 HEATER

### DTC Logic

INFOID:000000006882873

### DTC DETECTION LOGIC

A  
EC

| DTC No. | Trouble diagnosis name   | DTC detecting condition   | Possible cause  |
|---------|--|---|---|
| P0031   | Air fuel ratio (A/F) sensor 1 heater (bank 1) control circuit low  | The current amperage in the A/F sensor 1 heater circuit is out of the normal range.<br>(An excessively low voltage signal is sent to ECM through the A/F sensor 1 heater.)  | <ul style="list-style-type: none"><li>• Harness or connectors (The A/F sensor 1 heater circuit is open or shorted.)</li><li>• A/F sensor 1 heater</li></ul> |
| P0032   | Air fuel ratio (A/F) sensor 1 heater (bank 1) control circuit high | The current amperage in the A/F sensor 1 heater circuit is out of the normal range.<br>(An excessively high voltage signal is sent to ECM through the A/F sensor 1 heater.) | <ul style="list-style-type: none"><li>• Harness or connectors (The A/F sensor 1 heater circuit is shorted.)</li><li>• A/F sensor 1 heater</li></ul>         |
| P0051   | Air fuel ratio (A/F) sensor 1 heater (bank 2) control circuit low  | The current amperage in the A/F sensor 1 heater circuit is out of the normal range.<br>(An excessively low voltage signal is sent to ECM through the A/F sensor 1 heater.)  | <ul style="list-style-type: none"><li>• Harness or connectors (The A/F sensor 1 heater circuit is open or shorted.)</li><li>• A/F sensor 1 heater</li></ul> |
| P0052   | Air fuel ratio (A/F) sensor 1 heater (bank 2) control circuit high | The current amperage in the A/F sensor 1 heater circuit is out of the normal range.<br>(An excessively high voltage signal is sent to ECM through the A/F sensor 1 heater.) | <ul style="list-style-type: none"><li>• Harness or connectors (The A/F sensor 1 heater circuit is shorted.)</li><li>• A/F sensor 1 heater</li></ul>         |

### DTC CONFIRMATION PROCEDURE

#### 1. PRECONDITIONING

If DTC Confirmation Procedure has been previously conducted, always perform the following procedure before conducting the next test.

1. Turn ignition switch OFF and wait at least 10 seconds.
2. Turn ignition switch ON.
3. Turn ignition switch OFF and wait at least 10 seconds.

#### TESTING CONDITION:

Before performing the following procedure, confirm that battery voltage is between 10.5 V and 16 V at idle.

>> GO TO 2.

#### 2. PERFORM DTC CONFIRMATION PROCEDURE

1. Start engine and let it idle for at least 10 seconds.
2. Check 1st trip DTC.

Is 1st trip DTC detected?

- YES >> Go to [EC-195, "Diagnosis Procedure"](#).  
NG >> INSPECTION END

### Diagnosis Procedure

INFOID:000000006882874

#### 1. CHECK GROUND CONNECTION

1. Turn ignition switch OFF.
2. Check ground connection M95. Refer to Ground Inspection in [GI-47, "Circuit Inspection"](#).

Is the inspection result normal?

- YES >> GO TO 2.  
NO >> Repair or replace ground connection.

#### 2. CHECK AIR FUEL RATIO (A/F) SENSOR 1 POWER SUPPLY CIRCUIT

1. Disconnect air fuel ratio (A/F) sensor 1 harness connector.
2. Turn ignition switch ON.
3. Check the voltage between A/F sensor 1 harness connector and ground.

# P0031, P0032, P0051, P0052 A/F SENSOR 1 HEATER

< DTC/CIRCUIT DIAGNOSIS >

[VQ37VHR FOR USA AND CANADA]

| DTC          | A/F sensor 1 |           |          | Ground | Voltage         |
|--------------|--------------|-----------|----------|--------|-----------------|
|              | Bank         | Connector | Terminal |        |                 |
| P0031, P0032 | 1            | F3        | 4        | Ground | Battery voltage |
| P0051, P0052 | 2            | F20       | 4        |        |                 |

Is the inspection result normal?

YES >> GO TO 4.

NO >> GO TO 3.

## 3. DETECT MALFUNCTIONING PART

Check the following.

- Harness connectors E20, F40
- IPDM E/R harness connector E7
- 15 A fuse (No. 45)
- Harness for open or short between A/F sensor 1 and fuse

>> Repair or replace harness or connectors.

## 4. CHECK A/F SENSOR 1 HEATER OUTPUT SIGNAL CIRCUIT

1. Turn ignition switch OFF.
2. Disconnect ECM harness connector.
3. Check the continuity between A/F sensor 1 harness connector and ECM harness connector.

| DTC          | A/F sensor 1 |           |          | ECM       |          | Continuity |
|--------------|--------------|-----------|----------|-----------|----------|------------|
|              | Bank         | Connector | Terminal | Connector | Terminal |            |
| P0031, P0032 | 1            | F3        | 3        | F101      | 1        | Existed    |
| P0051, P0052 | 2            | F20       | 3        |           | 5        |            |

4. Also check harness for short to ground and short to power.

Is the inspection result normal?

YES >> GO TO 5.

NO >> Repair open circuit, short to ground or short to power in harness or connectors.

## 5. CHECK A/F SENSOR 1 HEATER

Refer to [EC-197, "Component Inspection"](#).

Is the inspection result normal?

YES >> GO TO 7.

NO >> GO TO 6.

## 6. REPLACE AIR FUEL RATIO (A/F) SENSOR 1

Replace malfunctioning air fuel ratio (A/F) sensor 1.

### CAUTION:

- Discard any A/F sensor which has been dropped from a height of more than 0.5 m (19.7 in) onto a hard surface such as a concrete floor; use a new one.
- Before installing new A/F sensor, clean exhaust system threads using Oxygen Sensor Thread Cleaner [commercial service tool (J-43897-18 or J-43897-12)] and approved Anti-seize Lubricant (commercial service tool).

>> INSPECTION END

## 7. CHECK INTERMITTENT INCIDENT

Perform [GI-44, "Intermittent Incident"](#).

>> Repair or replace.

# P0031, P0032, P0051, P0052 A/F SENSOR 1 HEATER

< DTC/CIRCUIT DIAGNOSIS >

[VQ37VHR FOR USA AND CANADA]

## Component Inspection

INFOID:000000006882875

### 1. CHECK AIR FUEL RATIO (A/F) SENSOR 1

1. Turn ignition switch OFF.
2. Disconnect A/F sensor 1 harness connector.
3. Check resistance between A/F sensor 1 terminals as follows.

| Terminal   | Resistance ( $\Omega$ )       |
|------------|-------------------------------|
| 3 and 4    | 1.98 - 2.66 [at 25°C (77°F)]  |
| 3 and 1, 2 | $\infty$                      |
| 4 and 1, 2 | (Continuity should not exist) |

Is the inspection result normal?

- YES >> INSPECTION END  
NO >> GO TO 2.

### 2. REPLACE AIR FUEL RATIO (A/F) SENSOR 1

Replace malfunctioning air fuel ratio (A/F) sensor 1.

**CAUTION:**

- Discard any A/F sensor which has been dropped from a height of more than 0.5 m (19.7 in) onto a hard surface such as a concrete floor; use a new one.
- Before installing new A/F sensor, clean exhaust system threads using Heated Oxygen Sensor Thread Cleaner [commercial service tool (J-43897-18 or J-43897-12)] and approved Anti-seize Lubricant (commercial service tool).

>> INSPECTION END

A  
EC  
C  
D  
E  
F  
G  
H  
I  
J  
K  
L  
M  
N  
O  
P

# P0037, P0038, P0057, P0058 HO2S2 HEATER

< DTC/CIRCUIT DIAGNOSIS >

[VQ37VHR FOR USA AND CANADA]

## P0037, P0038, P0057, P0058 HO2S2 HEATER

### DTC Logic

INFOID:000000006882876

### DTC DETECTION LOGIC

| DTC No. | Trouble diagnosis name                                      | DTC detecting condition  | Possible cause  |
|---------|---|--|---|
| P0037   | Heated oxygen sensor 2 heater (bank 1) control circuit low  | The current amperage in the heated oxygen sensor 2 heater circuit is out of the normal range. (An excessively low voltage signal is sent to ECM through the heated oxygen sensor 2 heater.)  | <ul style="list-style-type: none"><li>• Harness or connectors (The heated oxygen sensor 2 heater circuit is open or shorted.)</li><li>• Heated oxygen sensor 2 heater</li></ul> |
| P0038   | Heated oxygen sensor 2 heater (bank 1) control circuit high | The current amperage in the heated oxygen sensor 2 heater circuit is out of the normal range. (An excessively high voltage signal is sent to ECM through the heated oxygen sensor 2 heater.) | <ul style="list-style-type: none"><li>• Harness or connectors (The heated oxygen sensor 2 heater circuit is shorted.)</li><li>• Heated oxygen sensor 2 heater</li></ul>         |
| P0057   | Heated oxygen sensor 2 heater (bank 2) control circuit low  | The current amperage in the heated oxygen sensor 2 heater circuit is out of the normal range. (An excessively low voltage signal is sent to ECM through the heated oxygen sensor 2 heater.)  | <ul style="list-style-type: none"><li>• Harness or connectors (The heated oxygen sensor 2 heater circuit is open or shorted.)</li><li>• Heated oxygen sensor 2 heater</li></ul> |
| P0058   | Heated oxygen sensor 2 heater (bank 2) control circuit high | The current amperage in the heated oxygen sensor 2 heater circuit is out of the normal range. (An excessively high voltage signal is sent to ECM through the heated oxygen sensor 2 heater.) | <ul style="list-style-type: none"><li>• Harness or connectors (The heated oxygen sensor 2 heater circuit is shorted.)</li><li>• Heated oxygen sensor 2 heater</li></ul>         |

### DTC CONFIRMATION PROCEDURE

#### 1. PRECONDITIONING

If DTC Confirmation Procedure has been previously conducted, always perform the following procedure before conducting the next test.

1. Turn ignition switch OFF and wait at least 10 seconds.
2. Turn ignition switch ON.
3. Turn ignition switch OFF and wait at least 10 seconds.

#### TESTING CONDITION:

**Before performing the following procedure, confirm that battery voltage is between 11 V and 16 V at idle.**

>> GO TO 2.

#### 2. PERFORM DTC CONFIRMATION PROCEDURE

1. Start engine and warm it up to the normal operating temperature.
2. Turn ignition switch OFF and wait at least 10 seconds.
3. Turn ignition switch ON.
4. Turn ignition switch OFF and wait at least 10 seconds.
5. Start engine and keep the engine speed between 3,500 and 4,000 rpm for at least 1 minute under no load.
6. Let engine idle for 1 minute.
7. Check 1st trip DTC.

Is 1st trip DTC detected?

- YES >> Go to [EC-198, "Diagnosis Procedure"](#).  
NO >> INSPECTION END

### Diagnosis Procedure

INFOID:000000006882877

#### 1. CHECK GROUND CONNECTION

1. Turn ignition switch OFF.
2. Check ground connection M95. Refer to Ground Inspection in [GI-47, "Circuit Inspection"](#).

Is the inspection result normal?

- YES >> GO TO 2.  
NO >> Repair or replace ground connection.

# P0037, P0038, P0057, P0058 HO2S2 HEATER

< DTC/CIRCUIT DIAGNOSIS >

[VQ37VHR FOR USA AND CANADA]

## 2. CHECK HO2S2 POWER SUPPLY CIRCUIT

1. Disconnect heated oxygen sensor 2 (HO2S2) harness connector.
2. Turn ignition switch ON.
3. Check the voltage between HO2S2 harness connector and ground.

| DTC          | HO2S2 |           |          | Ground | Voltage         |
|--------------|-------|-----------|----------|--------|-----------------|
|              | Bank  | Connector | Terminal |        |                 |
| P0037, P0038 | 1     | F54       | 2        | Ground | Battery voltage |
| P0057, P0058 | 2     | F53       | 2        |        |                 |

Is the inspection result normal?

YES >> GO TO 4.

NO >> GO TO 3.

## 3. DETECT MALFUNCTIONING PART

Check the following.

- Harness connectors E20, F40
- IPDM E/R harness connector E7
- 15 A fuse (No. 45)
- Harness for open or short between heated oxygen sensor 2 and fuse

>> Repair open circuit, short to ground or short to power in harness or connectors.

## 4. CHECK HO2S2 OUTPUT SIGNAL CIRCUIT FOR OPEN AND SHORT

1. Turn ignition switch OFF.
2. Disconnect ECM harness connector.
3. Check the continuity between HO2S2 harness connector and ECM harness connector.

| DTC          | HO2S2 |           |          | ECM       |          | Continuity |
|--------------|-------|-----------|----------|-----------|----------|------------|
|              | Bank  | Connector | Terminal | Connector | Terminal |            |
| P0037, P0038 | 1     | F54       | 3        | F101      | 17       | Existed    |
| P0057, P0058 | 2     | F53       | 3        |           | 33       |            |

4. Also check harness for short to ground and short to power.

Is the inspection result normal?

YES >> GO TO 5.

NO >> Repair open circuit, short to ground or short to power in harness or connectors.

## 5. CHECK HEATED OXYGEN SENSOR 2 HEATER

Refer to [EC-200. "Component Inspection"](#).

Is the inspection result normal?

YES >> GO TO 7.

NO >> GO TO 6.

## 6. REPLACE HEATED OXYGEN SENSOR 2

Replace malfunctioning heated oxygen sensor 2.

### CAUTION:

- Discard any heated oxygen sensor which has been dropped from a height of more than 0.5 m (19.7 in) onto a hard surface such as a concrete floor; use a new one.
- Before installing new heated oxygen sensor, clean exhaust system threads using Oxygen Sensor Thread Cleaner [commercial service tool (J-43897-18 or J-43897-12)] and approved Anti-seize Lubricant (commercial service tool).

>> INSPECTION END

## 7. CHECK INTERMITTENT INCIDENT

# P0037, P0038, P0057, P0058 HO2S2 HEATER

< DTC/CIRCUIT DIAGNOSIS >

[VQ37VHR FOR USA AND CANADA]

Refer to [GI-44, "Intermittent Incident"](#).

>> INSPECTION END

## Component Inspection

INFOID:000000006882878

### 1. CHECK HEATED OXYGEN SENSOR 2 HEATER

1. Turn ignition switch OFF.
2. Disconnect heated oxygen sensor 2 harness connector.
3. Check resistance between HO2S2 terminals as follows.

| Terminal      | Resistance ( $\Omega$ )       |
|---------------|-------------------------------|
| 2 and 3       | 3.4 - 4.4 [at 25°C (77°F)]    |
| 1 and 2, 3, 4 | $\infty$                      |
| 4 and 1, 2, 3 | (Continuity should not exist) |

Is the inspection result normal?

- YES >> INSPECTION END  
NO >> GO TO 2.

### 2. REPLACE HEATED OXYGEN SENSOR 2

Replace malfunctioning heated oxygen sensor 2.

**CAUTION:**

- Discard any heated oxygen sensor which has been dropped from a height of more than 0.5 m (19.7 in) onto a hard surface such as a concrete floor; use a new one.
- Before installing new oxygen sensor, clean exhaust system threads using Oxygen Sensor Thread Cleaner [commercial service tool (J-43897-18 or J-43897-12)] and approved anti-seize lubricant (commercial service tool).

>> INSPECTION END



# P006A, P0101, P010B MAF SENSOR

< DTC/CIRCUIT DIAGNOSIS >

[VQ37VHR FOR USA AND CANADA]

## P006A, P0101, P010B MAF SENSOR

### DTC Logic

INFOID:000000006882879

### DTC DETECTION LOGIC

**NOTE:**

If DTC P006A, P0101 or P010B is displayed with other DTC, first perform the trouble diagnosis for other DTC.

| DTC No. | Trouble diagnosis name                                  | DTC detecting condition  | Possible cause  |
|---------|---|--|---|
| P006A   | Manifold absolute pressure - mass air flow correlation  | A difference exceeding the specified value develops between a value transmitted from the manifold absolute pressure (MAP) sensor to ECM and an estimated intake pressure of intake manifold calculated by ECM, based on a mass air flow sensor signal. | <ul style="list-style-type: none"> <li>• Harness or connectors (The sensor circuit is open or shorted.)</li> <li>• Mass air flow sensor</li> <li>• Manifold absolute pressure (MAP) sensor</li> <li>• EVAP control system pressure sensor</li> <li>• Intake air leaks</li> <li>• Intake air temperature sensor</li> </ul> |
| P0101   | Mass air flow sensor (bank 1) circuit range/performance | A difference exceeding the specified value develops between a signal transmitted from the mass air flow sensor (bank 1) to ECM and a signal transmitted from the mass air flow sensor (bank 2) to ECM.   | Mass air flow sensor (bank 1)   |
| P010B   | Mass air flow sensor (bank 2) circuit range/performance |  | Mass air flow sensor (bank 2)   |

### DTC CONFIRMATION PROCEDURE

#### 1. PRECONDITIONING

If DTC Confirmation Procedure has been previously conducted, always perform the following procedure before conducting the next test.

1. Turn ignition switch OFF and wait at least 10 seconds.
2. Turn ignition switch ON.
3. Turn ignition switch OFF and wait at least 10 seconds.

>> GO TO 2.

#### 2. PERFORM DTC CONFIRMATION PROCEDURE

 **With CONSULT**

1. Turn ignition switch ON and select "DATA MONITOR" mode with CONSULT.
2. Start engine and warm it up to normal operating temperature.
3. Accelerate the vehicle from 0 to 88 km/h (0 to 55 MPH) under the following conditions:

**CAUTION:**

**Always drive at a safe speed.**

**NOTE:**

- Accelerate with the accelerator pedal kept constant.
- The acceleration at engine speed 2,000 and 3,000 rpm allows easy diagnoses.

|                |             |
|----------------|-------------|
| ACCEL SEN 1    | 1.4 – 2.0 V |
| Selector lever | D position  |

4. Check 1st trip DTC.

 **Without CONSULT**

1. Start engine and warm it up to normal operating temperature.
2. With selector lever in D position, accelerate the vehicle from 0 to 88 km/h (0 to 55 MPH) under the following conditions:

**CAUTION:**

**Always drive at a safe speed.**

# P006A, P0101, P010B MAF SENSOR

[VQ37VHR FOR USA AND CANADA]

## < DTC/CIRCUIT DIAGNOSIS >

### NOTE:

- Accelerate with the accelerator pedal kept constant.
- The acceleration at engine speed 2,000 and 3,000 rpm allows easy diagnoses.

| Accelerator pedal position sensor 1 |                 | Ground | Voltage (V) |
|-------------------------------------|-----------------|--------|-------------|
| Connector                           | Terminal        |        |             |
| M153 <sup>*1</sup>                  | 4 <sup>*1</sup> | Ground | 1.4 – 2.0   |
| M9 <sup>*2</sup>                    | 3 <sup>*2</sup> |        |             |

\*1: With ICC

\*2: Without ICC

### 3. Check 1st trip DTC.

#### Is 1st trip DTC detected?

YES >> Go to [EC-202, "Diagnosis Procedure"](#).

NO >> INSPECTION END

## Diagnosis Procedure

INFOID:000000006882880

### 1. CHECK INTAKE SYSTEM

Check the following for connection.

- Air duct
- Vacuum hoses
- Intake air passage between air duct and intake manifold

#### Is the inspection result normal?

YES >> GO TO 2.

NO >> Reconnect the parts.

### 2. CHECK GROUND CONNECTION

1. Turn ignition switch OFF.
2. Check ground connection M95. Refer to Ground Inspection in [GI-47, "Circuit Inspection"](#).

#### Is the inspection result normal?

YES >> GO TO 3.

NO >> Repair or replace ground connection.

### 3. CHECK MASS AIR FLOW SENSOR POWER SUPPLY CIRCUIT

1. Disconnect mass air flow sensor harness connector.
2. Turn ignition switch ON.
3. Check the voltage between mass air flow sensor harness connector and ground.

| DTC          | Mass air flow sensor |           |          | Ground | Voltage         |
|--------------|----------------------|-----------|----------|--------|-----------------|
|              | Bank                 | Connector | Terminal |        |                 |
| P006A, P0101 | 1                    | F31       | 5        | Ground | Battery voltage |
| P006A, P010B | 2                    | F42       | 5        |        |                 |

#### Is the inspection result normal?

YES >> GO TO 5.

NO >> GO TO 4.

### 4. DETECT MALFUNCTIONING PART

Check the following.

- Harness connectors E106, M6
- Harness connectors M116, F103
- Harness for open or short between mass air flow sensor and ECM
- Harness for open or short between mass air flow sensor and IPDM E/R

>> Repair open circuit, short to ground or short to power in harness or connectors.

# P006A, P0101, P010B MAF SENSOR

[VQ37VHR FOR USA AND CANADA]

< DTC/CIRCUIT DIAGNOSIS >

## 5. CHECK MASS AIR FLOW SENSOR GROUND CIRCUIT FOR OPEN AND SHORT

1. Turn ignition switch OFF.
2. Disconnect ECM harness connector.
3. Check the continuity between mass air flow sensor harness connector and ECM harness connector.

| DTC          | Mass air flow sensor |           |          | ECM       |          | Continuity |
|--------------|----------------------|-----------|----------|-----------|----------|------------|
|              | Bank                 | Connector | Terminal | Connector | Terminal |            |
| P006A, P0101 | 1                    | F31       | 4        | F102      | 68       | Existed    |
| P006A, P010B | 2                    | F42       | 4        |           | 94       |            |

4. Also check harness for short to ground and short to power.

Is the inspection result normal?

YES >> GO TO 6.

NO >> Repair open circuit, short to ground or short to power in harness or connectors.

## 6. CHECK MASS AIR FLOW SENSOR INPUT SIGNAL CIRCUIT FOR OPEN AND SHORT

1. Check the continuity between mass air flow sensor harness connector and ECM harness connector.

| DTC          | Mass air flow sensor |           |          | ECM       |          | Continuity |
|--------------|----------------------|-----------|----------|-----------|----------|------------|
|              | Bank                 | Connector | Terminal | Connector | Terminal |            |
| P006A, P0101 | 1                    | F31       | 3        | F102      | 77       | Existed    |
| P006A, P010B | 2                    | F42       | 3        |           | 79       |            |

2. Also check harness for short to ground and short to power.

Is the inspection result normal?

YES >> GO TO 7.

NO >> Repair open circuit, short to ground or short to power in harness or connectors.

## 7. CHECK MANIFOLD ABSOLUTE PRESSURE (MAP) SENSOR

Check manifold absolute pressure (MAP) sensor. Refer to [EC-219. "Component Inspection"](#).

Is the inspection result normal?

YES >> GO TO 8.

NO >> Replace manifold absolute pressure (MAP) sensor. Refer to [EM-31. "Exploded View"](#).

## 8. CHECK INTAKE AIR TEMPERATURE SENSOR

Check intake air temperature sensor. Refer to [EC-227. "Component Inspection"](#).

Is the inspection result normal?

YES >> GO TO 9.

NO >> Replace mass air flow sensor (with intake air temperature sensor) (bank 1). Refer to [EM-29. "Exploded View"](#).

## 9. CHECK EVAP CONTROL SYSTEM PRESSURE SENSOR

Refer to [EC-349. "Component Inspection"](#).

Is the inspection result normal?

YES-1 (Only DTC P006A is detected)>>GO TO 10.

YES-2 (DTC P006A and P0101 are detected)>>GO TO 11.

YES-3 (DTC P006A and P010B are detected)>>GO TO 12.

NO >> Replace EVAP control system pressure sensor. Refer to [FL-13. "Exploded View"](#).

## 10. CHECK MASS AIR FLOW SENSOR

Refer to [EC-204. "Component Inspection"](#).

Is the inspection result normal?

YES >> GO TO 13.

NO >> Replace mass air flow sensor (bank 1) and (bank 2). Refer to [EM-29. "Exploded View"](#).

# P006A, P0101, P010B MAF SENSOR

[VQ37VHR FOR USA AND CANADA]

< DTC/CIRCUIT DIAGNOSIS >

## 11. CHECK MASS AIR FLOW SENSOR (BANK 1)

Check mass air flow sensor (bank 1). Refer to [EC-213, "Component Inspection"](#).

Is the inspection result normal?

YES >> GO TO 13.

NO >> Replace mass air flow sensor (bank 1). Refer to [EM-29, "Exploded View"](#).

## 12. CHECK MASS AIR FLOW SENSOR (BANK 2)

Check mass air flow sensor (bank 2). Refer to [EC-213, "Component Inspection"](#).

Is the inspection result normal?

YES >> GO TO 13.

NO >> Replace mass air flow sensor (bank 2). Refer to [EM-29, "Exploded View"](#).

## 13. CHECK INTERMITTENT INCIDENT

Refer to [GI-44, "Intermittent Incident"](#).

>> INSPECTION END

## Component Inspection

INFOID:000000006882881

## 1. CHECK MASS AIR FLOW SENSOR-I

### With CONSULT

1. Turn ignition switch OFF.
2. Reconnect all harness connectors disconnected.
3. Start engine and warm it up to normal operating temperature.
4. Connect CONSULT and select "DATA MONITOR" mode.
5. Select "MAS A/F SE-B1" and "MAS A/F SE-B2", and check the indication.

| Monitor item                   | Condition  | Indication (V)            |
|--------------------------------|--|---------------------------|
| MAS A/F SE-B1<br>MAS A/F SE-B2 | Ignition switch ON (Engine stopped.)                             | Approx. 0.4               |
|                                | Idle (Engine is warmed-up to normal operating temperature.)      | 0.7 - 1.2                 |
|                                | 2,500 rpm (Engine is warmed-up to normal operating temperature.) | 1.3 - 1.7                 |
|                                | Idle to about 4,000 rpm  | 0.7 - 1.2 to Approx. 2.4* |

\*: Check for linear voltage rise in response to engine being increased to about 4,000 rpm.

### Without CONSULT

1. Turn ignition switch OFF.
2. Reconnect all harness connectors disconnected.
3. Start engine and warm it up to normal operating temperature.
4. Check the voltage between ECM harness connector terminals under the following conditions.

# P006A, P0101, P010B MAF SENSOR

< DTC/CIRCUIT DIAGNOSIS >

[VQ37VHR FOR USA AND CANADA]

| ECM       |                                       |          | Condition  | Voltage (V)               |
|-----------|---------------------------------------|----------|--|---------------------------|
| Connector | +                                     | -        |  |                           |
|           | Terminal                              | Terminal |  |                           |
| F102      | 77<br>[MAF sensor (bank 1)<br>signal] | 68       | Ignition switch ON (Engine stopped.)                             | Approx. 0.4               |
|           |                                       |          | Idle (Engine is warmed-up to normal operating temperature.)      | 0.7 - 1.2                 |
|           |                                       |          | 2,500 rpm (Engine is warmed-up to normal operating temperature.) | 1.3 - 1.7                 |
|           |                                       |          | Idle to about 4,000 rpm  | 0.7 - 1.2 to Approx. 2.4* |
|           | 79<br>[MAF sensor (bank 2)<br>signal] | 94       | Ignition switch ON (Engine stopped.)                             | Approx. 0.4               |
|           |                                       |          | Idle (Engine is warmed-up to normal operating temperature.)      | 0.7 - 1.2                 |
|           |                                       |          | 2,500 rpm (Engine is warmed-up to normal operating temperature.) | 1.3 - 1.7                 |
|           |                                       |          | Idle to about 4,000 rpm  | 0.7 - 1.2 to Approx. 2.4* |

\*: Check for linear voltage rise in response to engine being increased to about 4,000 rpm.

## Is the inspection result normal?

- YES >> INSPECTION END  
NO >> GO TO 2.

## 2. CHECK FOR THE CAUSE OF UNEVEN AIR FLOW THROUGH MASS AIR FLOW SENSOR

- Turn ignition switch OFF.
- Check for the cause of uneven air flow through mass air flow sensor. Refer to the following.
  - Crushed air ducts
  - Malfunctioning seal of air cleaner element
  - Uneven dirt of air cleaner element
  - Improper specification of intake air system parts

## Is the inspection result normal?

- YES >> GO TO 4.  
NO >> GO TO 3.

## 3. CHECK MASS AIR FLOW SENSOR-II

### With CONSULT

- Repair or replace malfunctioning part.
- Start engine and warm it up to normal operating temperature.
- Connect CONSULT and select "DATA MONITOR" mode.
- Select "MAS A/F SE-B1" and "MAS A/F SE-B2", and check the indication.

| Monitor item                   | Condition  | Indication (V)            |
|--------------------------------|--|---------------------------|
| MAS A/F SE-B1<br>MAS A/F SE-B2 | Ignition switch ON (Engine stopped.)                             | Approx. 0.4               |
|                                | Idle (Engine is warmed-up to normal operating temperature.)      | 0.7 - 1.2                 |
|                                | 2,500 rpm (Engine is warmed-up to normal operating temperature.) | 1.3 - 1.7                 |
|                                | Idle to about 4,000 rpm  | 0.7 - 1.2 to Approx. 2.4* |

\*: Check for linear voltage rise in response to engine being increased to about 4,000 rpm.

### Without CONSULT

- Repair or replace malfunctioning part.
- Start engine and warm it up to normal operating temperature.
- Check the voltage between ECM harness connector terminals under the following conditions.

# P006A, P0101, P010B MAF SENSOR

< DTC/CIRCUIT DIAGNOSIS >

[VQ37VHR FOR USA AND CANADA]

| ECM       |                                       |               | Condition  | Voltage (V)               |
|-----------|---------------------------------------|---------------|--|---------------------------|
| Connector | +<br>Terminal                         | -<br>Terminal |  |                           |
| F102      | 77<br>[MAF sensor (bank 1)<br>signal] | 68            | Ignition switch ON (Engine stopped.)                             | Approx. 0.4               |
|           |                                       |               | Idle (Engine is warmed-up to normal operating temperature.)      | 0.7 - 1.2                 |
|           |                                       |               | 2,500 rpm (Engine is warmed-up to normal operating temperature.) | 1.3 - 1.7                 |
|           |                                       |               | Idle to about 4,000 rpm  | 0.7 - 1.2 to Approx. 2.4* |
|           | 79<br>[MAF sensor (bank 2)<br>signal] | 94            | Ignition switch ON (Engine stopped.)                             | Approx. 0.4               |
|           |                                       |               | Idle (Engine is warmed-up to normal operating temperature.)      | 0.7 - 1.2                 |
|           |                                       |               | 2,500 rpm (Engine is warmed-up to normal operating temperature.) | 1.3 - 1.7                 |
|           |                                       |               | Idle to about 4,000 rpm  | 0.7 - 1.2 to Approx. 2.4* |

\*: Check for linear voltage rise in response to engine being increased to about 4,000 rpm.

**Is the inspection result normal?**

- YES >> INSPECTION END  
 NO >> GO TO 4.

## 4. CHECK MASS AIR FLOW SENSOR-III

**With CONSULT**

1. Turn ignition switch OFF.
2. Disconnect mass air flow sensor harness connector and reconnect it again.
3. Start engine and warm it up to normal operating temperature.
4. Connect CONSULT and select "DATA MONITOR" mode.
5. Select "MAS A/F SE-B1" and "MAS A/F SE-B2", and check the indication.

| Monitor item                   | Condition  | Indication (V)            |
|--------------------------------|--|---------------------------|
| MAS A/F SE-B1<br>MAS A/F SE-B2 | Ignition switch ON (Engine stopped.)                             | Approx. 0.4               |
|                                | Idle (Engine is warmed-up to normal operating temperature.)      | 0.7 - 1.2                 |
|                                | 2,500 rpm (Engine is warmed-up to normal operating temperature.) | 1.3 - 1.7                 |
|                                | Idle to about 4,000 rpm  | 0.7 - 1.2 to Approx. 2.4* |

\*: Check for linear voltage rise in response to engine being increased to about 4,000 rpm.

**Without CONSULT**

1. Turn ignition switch OFF.
2. Disconnect mass air flow sensor harness connector and reconnect it again.
3. Start engine and warm it up to normal operating temperature.
4. Check the voltage between ECM harness connector terminals under the following conditions.

# P006A, P0101, P010B MAF SENSOR

< DTC/CIRCUIT DIAGNOSIS >

[VQ37VHR FOR USA AND CANADA]

| ECM       |                                       |               | Condition  | Voltage (V)               |
|-----------|---------------------------------------|---------------|--|---------------------------|
| Connector | +<br>Terminal                         | -<br>Terminal |  |                           |
| F102      | 77<br>[MAF sensor (bank 1)<br>signal] | 68            | Ignition switch ON (Engine stopped.)                             | Approx. 0.4               |
|           |                                       |               | Idle (Engine is warmed-up to normal operating temperature.)      | 0.7 - 1.2                 |
|           |                                       |               | 2,500 rpm (Engine is warmed-up to normal operating temperature.) | 1.3 - 1.7                 |
|           |                                       |               | Idle to about 4,000 rpm  | 0.7 - 1.2 to Approx. 2.4* |
|           | 79<br>[MAF sensor (bank 2)<br>signal] | 94            | Ignition switch ON (Engine stopped.)                             | Approx. 0.4               |
|           |                                       |               | Idle (Engine is warmed-up to normal operating temperature.)      | 0.7 - 1.2                 |
|           |                                       |               | 2,500 rpm (Engine is warmed-up to normal operating temperature.) | 1.3 - 1.7                 |
|           |                                       |               | Idle to about 4,000 rpm  | 0.7 - 1.2 to Approx. 2.4* |

\*: Check for linear voltage rise in response to engine being increased to about 4,000 rpm.

**Is the inspection result normal?**

- YES >> INSPECTION END
- NO >> Clean or replace malfunctioning mass air flow sensor.

A  
EC  
C  
D  
E  
F  
G  
H  
I  
J  
K  
L  
M  
N  
O  
P

# P0075, P0081 IVT CONTROL SOLENOID VALVE

< DTC/CIRCUIT DIAGNOSIS >

[VQ37VHR FOR USA AND CANADA]

## P0075, P0081 IVT CONTROL SOLENOID VALVE

### DTC Logic

INFOID:000000006882882

### DTC DETECTION LOGIC

| DTC No. | Trouble diagnosis name                                      | DTC detecting condition  | Possible cause  |
|---------|---|--|---|
| P0075   | Intake valve timing control solenoid valve (bank 1) circuit | An improper voltage is sent to the ECM through intake valve timing control solenoid valve. | <ul style="list-style-type: none"><li>• Harness or connectors (Intake valve timing control solenoid valve circuit is open or shorted.)</li><li>• Intake valve timing control solenoid valve</li></ul> |
| P0081   | Intake valve timing control solenoid valve (bank 2) circuit |  |   |

### DTC CONFIRMATION PROCEDURE

#### 1. PRECONDITIONING

If DTC Confirmation Procedure has been previously conducted, always perform the following procedure before conducting the next test.

1. Turn ignition switch OFF and wait at least 10 seconds.
2. Turn ignition switch ON.
3. Turn ignition switch OFF and wait at least 10 seconds.

>> GO TO 2.

#### 2. PERFORM DTC CONFIRMATION PROCEDURE

1. Start engine and let it idle for 5 seconds.
2. Check 1st trip DTC.

Is 1st trip DTC detected?

- YES >> Go to [EC-208, "Diagnosis Procedure"](#).  
NO >> INSPECTION END

### Diagnosis Procedure

INFOID:000000006882883

#### 1. CHECK INTAKE VALVE TIMING CONTROL SOLENOID VALVE POWER SUPPLY CIRCUIT

1. Turn ignition switch OFF.
2. Disconnect intake valve timing (IVT) control solenoid valve harness connector.
3. Turn ignition switch ON.
4. Check the voltage between intake valve timing control solenoid valve harness connector and ground.

| DTC   | IVT control solenoid valve |           |          | Ground | Voltage         |
|-------|----------------------------|-----------|----------|--------|-----------------|
|       | Bank                       | Connector | Terminal |        |                 |
| P0075 | 1                          | F28       | 2        | Ground | Battery voltage |
| P0081 | 2                          | F29       | 2        |        |                 |

Is the inspection result normal?

- YES >> GO TO 3.  
NO >> GO TO 2.

#### 2. DETECT MALFUNCTIONING PART

Check the following.

- Harness connectors E20, F40
- Harness for open or short between intake valve timing control solenoid valve and IPDM E/R

>> Repair open circuit, short to ground or short to power in harness or connectors.

#### 3. CHECK INTAKE VALVE TIMING CONTROL SOLENOID VALVE OUTPUT SIGNAL CIRCUIT FOR OPEN AND SHORT



# P0075, P0081 IVT CONTROL SOLENOID VALVE

[VQ37VHR FOR USA AND CANADA]

## < DTC/CIRCUIT DIAGNOSIS >

1. Turn ignition switch OFF.
2. Disconnect ECM harness connector.
3. Check the continuity between intake valve timing control solenoid valve harness connector and ECM harness connector.

| DTC   | IVT control solenoid valve |           |          | ECM       |          | Continuity |
|-------|----------------------------|-----------|----------|-----------|----------|------------|
|       | Bank                       | Connector | Terminal | Connector | Terminal |            |
| P0075 | 1                          | F28       | 1        | F101      | 18       | Existed    |
| P0081 | 2                          | F29       | 1        |           | 29       |            |

4. Also check harness for short to ground and short to power.

Is the inspection result normal?

YES >> GO TO 4.

NO >> Repair open circuit, short to ground or short to power in harness or connectors.

## 4.CHECK INTAKE VALVE TIMING CONTROL SOLENOID VALVE

Refer to [EC-209, "Component Inspection"](#).

Is the inspection result normal?

YES >> GO TO 5.

NO >> Replace malfunctioning intake valve timing control solenoid valve. Refer to [EM-52, "Exploded View"](#).

## 5.CHECK INTERMITTENT INCIDENT

Refer to [GI-44, "Intermittent Incident"](#).

>> INSPECTION END

## Component Inspection

INFOID:000000006882884

## 1.CHECK INTAKE VALVE TIMING CONTROL SOLENOID VALVE-I

1. Turn ignition switch OFF.
2. Disconnect intake valve timing control solenoid valve harness connector.
3. Check resistance between intake valve timing control solenoid valve terminals as follows.

| Terminals         | Resistance ( $\Omega$ )                   |
|-------------------|---|
| 1 and 2           | 7.0 - 7.7 [at 20°C (68°F)]                |
| 1 or 2 and ground | $\infty$<br>(Continuity should not exist) |

Is the inspection result normal?

YES >> GO TO 2.

NO >> Replace malfunctioning intake valve timing control solenoid valve. Refer to [EM-52, "Exploded View"](#).

## 2.CHECK INTAKE VALVE TIMING CONTROL SOLENOID VALVE-II

1. Remove intake valve timing control solenoid valve.
2. Provide 12 V DC between intake valve timing control solenoid valve terminals 1 and 2, and then interrupt it. Make sure that the plunger moves as shown in the figure.

### CAUTION:

Do not apply 12 V DC continuously for 5 seconds or more. Doing so may result in damage to the coil in intake valve timing control solenoid valve.

### NOTE:

Always replace O-ring when intake valve timing control solenoid valve is removed.

Is the inspection result normal?

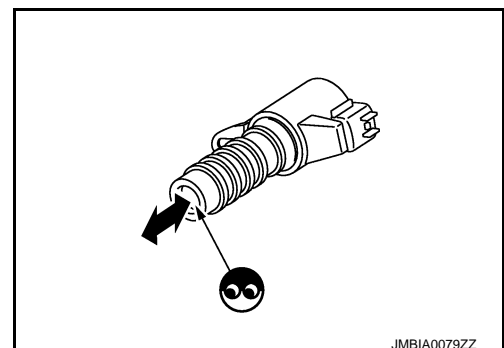

## P0075, P0081 IVT CONTROL SOLENOID VALVE

[VQ37VHR FOR USA AND CANADA]

< DTC/CIRCUIT DIAGNOSIS >

---

YES >> INSPECTION END

NO >> Replace malfunctioning intake valve timing control solenoid valve. Refer to [EM-52, "Exploded View"](#).

# P0102, P0103, P010C, P010D MAF SENSOR

< DTC/CIRCUIT DIAGNOSIS >

[VQ37VHR FOR USA AND CANADA]

## P0102, P0103, P010C, P010D MAF SENSOR

### DTC Logic

INFOID:000000006882885

#### DTC DETECTION LOGIC

| DTC No. | Trouble diagnosis name                           | DTC detecting condition                                     | Possible cause   |
|---------|--|---|--|
| P0102   | Mass air flow sensor (bank 1) circuit low input  | An excessively low voltage from the sensor is sent to ECM.  | <ul style="list-style-type: none"><li>• Harness or connectors (The sensor circuit is open or shorted.)</li><li>• Intake air leaks</li><li>• Mass air flow sensor</li></ul> |
| P0103   | Mass air flow sensor (bank 1) circuit high input | An excessively high voltage from the sensor is sent to ECM. | <ul style="list-style-type: none"><li>• Harness or connectors (The sensor circuit is open or shorted.)</li><li>• Mass air flow sensor</li></ul>                            |
| P010C   | Mass air flow sensor (bank 2) circuit low input  | An excessively low voltage from the sensor is sent to ECM.  | <ul style="list-style-type: none"><li>• Harness or connectors (The sensor circuit is open or shorted.)</li><li>• Intake air leaks</li><li>• Mass air flow sensor</li></ul> |
| P010D   | Mass air flow sensor (bank 2) circuit high input | An excessively high voltage from the sensor is sent to ECM. | <ul style="list-style-type: none"><li>• Harness or connectors (The sensor circuit is open or shorted.)</li><li>• Mass air flow sensor</li></ul>                            |

#### DTC CONFIRMATION PROCEDURE

##### 1. PRECONDITIONING

If DTC Confirmation Procedure has been previously conducted, always perform the following procedure before conducting the next test.

1. Turn ignition switch OFF and wait at least 10 seconds.
2. Turn ignition switch ON.
3. Turn ignition switch OFF and wait at least 10 seconds.

##### Which DTC is detected?

P0102, P010C>>GO TO 2.

P0103, P010D>>GO TO 3.

##### 2. PERFORM DTC CONFIRMATION PROCEDURE FOR DTC P0102 AND P010C

1. Start engine and wait at least 5 seconds.
2. Check DTC.

##### Is DTC detected?

YES >> Go to [EC-211, "Diagnosis Procedure"](#).

NO >> INSPECTION END

##### 3. PERFORM DTC CONFIRMATION PROCEDURE FOR DTC P0103 AND P010D-I

1. Turn ignition switch ON and wait at least 5 seconds.
2. Check DTC.

##### Is DTC detected?

YES >> Go to [EC-211, "Diagnosis Procedure"](#).

NO >> GO TO 4.

##### 4. PERFORM DTC CONFIRMATION PROCEDURE FOR DTC P0103 AND P010D-II

1. Start engine and wait at least 5 seconds.
2. Check DTC.

##### Is DTC detected?

YES >> Go to [EC-211, "Diagnosis Procedure"](#).

NO >> INSPECTION END

#### Diagnosis Procedure

INFOID:000000006882886

##### 1. INSPECTION START

# P0102, P0103, P010C, P010D MAF SENSOR

[VQ37VHR FOR USA AND CANADA]

## < DTC/CIRCUIT DIAGNOSIS >

Confirm the detected DTC.

Which DTC is detected?

- P0102, P010C>>GO TO 2.
- P0103, P010D>>GO TO 3.

### 2.CHECK INTAKE SYSTEM

Check the following for connection.

- Air duct
- Vacuum hoses
- Intake air passage between air duct to intake manifold

Is the inspection result normal?

- YES >> GO TO 3.
- NO >> Reconnect the parts.

### 3.CHECK GROUND CONNECTION

1. Turn ignition switch OFF.
2. Check ground connection M95. Refer to Ground Inspection in [GI-47. "Circuit Inspection"](#).

Is the inspection result normal?

- YES >> GO TO 4.
- NO >> Repair or replace ground connection.

### 4.CHECK MAF SENSOR POWER SUPPLY CIRCUIT

1. Disconnect mass air flow (MAF) sensor harness connector.
2. Turn ignition switch ON.
3. Check the voltage between MAF sensor harness connector and ground.

| DTC          | MAF sensor |           |          | Ground | Voltage         |
|--------------|------------|-----------|----------|--------|-----------------|
|              | Bank       | Connector | Terminal |        |                 |
| P0102, P0103 | 1          | F31       | 5        | Ground | Battery voltage |
| P010C, P010D | 2          | F42       | 5        |        |                 |

Is the inspection result normal?

- YES >> GO TO 6.
- NO >> GO TO 5.

### 5.DETECT MALFUNCTIONING PART

Check the following.

- Harness connectors E106, M6
- Harness connectors M116, F103
- Harness for open or short between mass air flow sensor and ECM
- Harness for open or short between mass air flow sensor and IPDM E/R

>> Repair open circuit, short to ground or short to power in harness or connectors.

### 6.CHECK MAF SENSOR GROUND CIRCUIT FOR OPEN AND SHORT

1. Turn ignition switch OFF.
2. Disconnect ECM harness connector.
3. Check the continuity between MAF sensor harness connector and ECM harness connector.

| DTC          | MAF sensor |           |          | ECM       |          | Continuity |
|--------------|------------|-----------|----------|-----------|----------|------------|
|              | Bank       | Connector | Terminal | Connector | Terminal |            |
| P0102, P0103 | 1          | F31       | 4        | F102      | 68       | Existed    |
| P010C, P010D | 2          | F42       | 4        |           | 94       |            |

4. Also check harness for short to ground and short to power.

Is the inspection result normal?

- YES >> GO TO 7.

# P0102, P0103, P010C, P010D MAF SENSOR

[VQ37VHR FOR USA AND CANADA]

< DTC/CIRCUIT DIAGNOSIS >

NO >> Repair open circuit, short to ground or short to power in harness or connectors.

## 7. CHECK MAF SENSOR INPUT SIGNAL CIRCUIT FOR OPEN AND SHORT

1. Check the continuity between MAF sensor harness connector and ECM harness connector.

| DTC          | MAF sensor |           |          | ECM       |          | Continuity |
|--------------|------------|-----------|----------|-----------|----------|------------|
|              | Bank       | Connector | Terminal | Connector | Terminal |            |
| P0102, P0103 | 1          | F31       | 3        | F102      | 77       | Existed    |
| P010C, P010D | 2          | F42       | 3        |           | 79       |            |

2. Also check harness for short to ground and short to power.

Is the inspection result normal?

YES >> GO TO 8.

NO >> Repair open circuit, short to ground or short to power in harness or connectors.

## 8. CHECK MASS AIR FLOW SENSOR

Refer to [EC-213, "Component Inspection"](#).

Is the inspection result normal?

YES >> GO TO 9.

NO >> Replace malfunctioning mass air flow sensor. Refer to [EM-29, "Exploded View"](#).

## 9. CHECK INTERMITTENT INCIDENT

Refer to [GI-44, "Intermittent Incident"](#).

>> INSPECTION END

## Component Inspection

INFOID:000000006882887

### 1. CHECK MASS AIR FLOW SENSOR-I

#### With CONSULT

1. Turn ignition switch OFF.
2. Reconnect all harness connectors disconnected.
3. Start engine and warm it up to normal operating temperature.
4. Connect CONSULT and select "DATA MONITOR" mode.
5. Select "MAS A/F SE-B1" and "MAS A/F SE-B2", and check the indication.

| Monitor item                   | Condition  | Indication (V)            |
|--------------------------------|--|---------------------------|
| MAS A/F SE-B1<br>MAS A/F SE-B2 | Ignition switch ON (Engine stopped.)                             | Approx. 0.4               |
|                                | Idle (Engine is warmed-up to normal operating temperature.)      | 0.7 - 1.2                 |
|                                | 2,500 rpm (Engine is warmed-up to normal operating temperature.) | 1.3 - 1.7                 |
|                                | Idle to about 4,000 rpm  | 0.7 - 1.2 to Approx. 2.4* |

\*: Check for linear voltage rise in response to engine being increased to about 4,000 rpm.

#### Without CONSULT

1. Turn ignition switch OFF.
2. Reconnect all harness connectors disconnected.
3. Start engine and warm it up to normal operating temperature.
4. Check the voltage between ECM harness connector terminals under the following conditions.

# P0102, P0103, P010C, P010D MAF SENSOR

< DTC/CIRCUIT DIAGNOSIS >

[VQ37VHR FOR USA AND CANADA]

| ECM       |                                       |          | Condition  | Voltage (V)               |
|-----------|---------------------------------------|----------|--|---------------------------|
| Connector | +                                     | -        |  |                           |
|           | Terminal                              | Terminal |  |                           |
| F102      | 77<br>[MAF sensor (bank 1)<br>signal] | 68       | Ignition switch ON (Engine stopped.)                             | Approx. 0.4               |
|           |                                       |          | Idle (Engine is warmed-up to normal operating temperature.)      | 0.7 - 1.2                 |
|           |                                       |          | 2,500 rpm (Engine is warmed-up to normal operating temperature.) | 1.3 - 1.7                 |
|           |                                       |          | Idle to about 4,000 rpm  | 0.7 - 1.2 to Approx. 2.4* |
|           | 79<br>[MAF sensor (bank 2)<br>signal] | 94       | Ignition switch ON (Engine stopped.)                             | Approx. 0.4               |
|           |                                       |          | Idle (Engine is warmed-up to normal operating temperature.)      | 0.7 - 1.2                 |
|           |                                       |          | 2,500 rpm (Engine is warmed-up to normal operating temperature.) | 1.3 - 1.7                 |
|           |                                       |          | Idle to about 4,000 rpm  | 0.7 - 1.2 to Approx. 2.4* |

\*: Check for linear voltage rise in response to engine being increased to about 4,000 rpm.

## Is the inspection result normal?

YES >> INSPECTION END

NO >> GO TO 2.

## 2. CHECK FOR THE CAUSE OF UNEVEN AIR FLOW THROUGH MASS AIR FLOW SENSOR

1. Turn ignition switch OFF.
2. Check for the cause of uneven air flow through mass air flow sensor. Refer to the following.
  - Crushed air ducts
  - Malfunctioning seal of air cleaner element
  - Uneven dirt of air cleaner element
  - Improper specification of intake air system parts

## Is the inspection result normal?

YES >> GO TO 4.

NO >> GO TO 3.

## 3. CHECK MASS AIR FLOW SENSOR-II

### With CONSULT

1. Repair or replace malfunctioning part.
2. Start engine and warm it up to normal operating temperature.
3. Connect CONSULT and select "DATA MONITOR" mode.
4. Select "MAS A/F SE-B1" and "MAS A/F SE-B2", and check the indication.

| Monitor item                   | Condition  | Indication (V)            |
|--------------------------------|--|---------------------------|
| MAS A/F SE-B1<br>MAS A/F SE-B2 | Ignition switch ON (Engine stopped.)                             | Approx. 0.4               |
|                                | Idle (Engine is warmed-up to normal operating temperature.)      | 0.7 - 1.2                 |
|                                | 2,500 rpm (Engine is warmed-up to normal operating temperature.) | 1.3 - 1.7                 |
|                                | Idle to about 4,000 rpm  | 0.7 - 1.2 to Approx. 2.4* |

\*: Check for linear voltage rise in response to engine being increased to about 4,000 rpm.

### Without CONSULT

1. Repair or replace malfunctioning part.
2. Start engine and warm it up to normal operating temperature.
3. Check the voltage between ECM harness connector terminals under the following conditions.

# P0102, P0103, P010C, P010D MAF SENSOR

< DTC/CIRCUIT DIAGNOSIS >

[VQ37VHR FOR USA AND CANADA]

| ECM       |                                       |          | Condition  | Voltage (V)               |
|-----------|---------------------------------------|----------|--|---------------------------|
| Connector | +                                     | -        |  |                           |
|           | Terminal                              | Terminal |  |                           |
| F102      | 77<br>[MAF sensor (bank 1)<br>signal] | 68       | Ignition switch ON (Engine stopped.)                             | Approx. 0.4               |
|           |                                       |          | Idle (Engine is warmed-up to normal operating temperature.)      | 0.7 - 1.2                 |
|           |                                       |          | 2,500 rpm (Engine is warmed-up to normal operating temperature.) | 1.3 - 1.7                 |
|           |                                       |          | Idle to about 4,000 rpm  | 0.7 - 1.2 to Approx. 2.4* |
|           | 79<br>[MAF sensor (bank 2)<br>signal] | 94       | Ignition switch ON (Engine stopped.)                             | Approx. 0.4               |
|           |                                       |          | Idle (Engine is warmed-up to normal operating temperature.)      | 0.7 - 1.2                 |
|           |                                       |          | 2,500 rpm (Engine is warmed-up to normal operating temperature.) | 1.3 - 1.7                 |
|           |                                       |          | Idle to about 4,000 rpm  | 0.7 - 1.2 to Approx. 2.4* |

\*: Check for linear voltage rise in response to engine being increased to about 4,000 rpm.

## Is the inspection result normal?

YES >> INSPECTION END

NO >> GO TO 4.

## 4. CHECK MASS AIR FLOW SENSOR-III

### With CONSULT

1. Turn ignition switch OFF.
2. Disconnect mass air flow sensor harness connector and reconnect it again.
3. Start engine and warm it up to normal operating temperature.
4. Connect CONSULT and select "DATA MONITOR" mode.
5. Select "MAS A/F SE-B1" and "MAS A/F SE-B2", and check the indication.

| Monitor item                   | Condition  | Indication (V)            |
|--------------------------------|--|---------------------------|
| MAS A/F SE-B1<br>MAS A/F SE-B2 | Ignition switch ON (Engine stopped.)                             | Approx. 0.4               |
|                                | Idle (Engine is warmed-up to normal operating temperature.)      | 0.7 - 1.2                 |
|                                | 2,500 rpm (Engine is warmed-up to normal operating temperature.) | 1.3 - 1.7                 |
|                                | Idle to about 4,000 rpm  | 0.7 - 1.2 to Approx. 2.4* |

\*: Check for linear voltage rise in response to engine being increased to about 4,000 rpm.

### Without CONSULT

1. Turn ignition switch OFF.
2. Disconnect mass air flow sensor harness connector and reconnect it again.
3. Start engine and warm it up to normal operating temperature.
4. Check the voltage between ECM harness connector terminals under the following conditions.

# P0102, P0103, P010C, P010D MAF SENSOR

< DTC/CIRCUIT DIAGNOSIS >

[VQ37VHR FOR USA AND CANADA]

| ECM       |                                       |          | Condition  | Voltage (V)               |
|-----------|---------------------------------------|----------|--|---------------------------|
| Connector | +                                     | -        |  |                           |
|           | Terminal                              | Terminal |  |                           |
| F102      | 77<br>[MAF sensor (bank 1)<br>signal] | 68       | Ignition switch ON (Engine stopped.)                             | Approx. 0.4               |
|           |                                       |          | Idle (Engine is warmed-up to normal operating temperature.)      | 0.7 - 1.2                 |
|           |                                       |          | 2,500 rpm (Engine is warmed-up to normal operating temperature.) | 1.3 - 1.7                 |
|           |                                       |          | Idle to about 4,000 rpm  | 0.7 - 1.2 to Approx. 2.4* |
|           | 79<br>[MAF sensor (bank 2)<br>signal] | 94       | Ignition switch ON (Engine stopped.)                             | Approx. 0.4               |
|           |                                       |          | Idle (Engine is warmed-up to normal operating temperature.)      | 0.7 - 1.2                 |
|           |                                       |          | 2,500 rpm (Engine is warmed-up to normal operating temperature.) | 1.3 - 1.7                 |
|           |                                       |          | Idle to about 4,000 rpm  | 0.7 - 1.2 to Approx. 2.4* |

\*: Check for linear voltage rise in response to engine being increased to about 4,000 rpm.

## Is the inspection result normal?

YES >> INSPECTION END

NO >> Clean or replace malfunctioning mass air flow sensor. Refer to [EM-29, "Exploded View"](#).



# P0106 MANIFOLD ABSOLUTE PRESSURE SENSOR

< DTC/CIRCUIT DIAGNOSIS >

[VQ37VHR FOR USA AND CANADA]

## P0106 MANIFOLD ABSOLUTE PRESSURE SENSOR

### DTC Logic

INFOID:000000006882888

### DTC DETECTION LOGIC

#### NOTE:

If DTC P0106 is displayed with other DTC, first perform the trouble diagnosis for other DTC.

| DTC No. | Trouble diagnosis name                                     | DTC detecting condition  | Possible cause  |
|---------|--|--|---|
| P0106   | Manifold absolute pressure (MAP) circuit range/performance | A difference exceeding the specified value develops between a value transmitted from the manifold absolute pressure (MAP) sensor to ECM and an estimated intake pressure of intake manifold calculated by ECM. | <ul style="list-style-type: none"><li>• Harness or connectors (The sensor circuit is open or shorted.)</li><li>• Manifold absolute pressure (MAP) sensor</li><li>• Intake air leaks</li></ul> |

### DTC CONFIRMATION PROCEDURE

#### 1. PRECONDITIONING

If DTC Confirmation Procedure has been previously conducted, always perform the following procedure before conducting the next test.

1. Turn ignition switch OFF and wait at least 10 seconds.
2. Turn ignition switch ON.
3. Turn ignition switch OFF and wait at least 10 seconds.

If engine will not start or stops soon, wait at least 10 seconds with engine stopped (Ignition switch ON) instead of running engine at idle speed.

>> GO TO 2.

#### 2. PERFORM DTC CONFIRMATION PROCEDURE

##### With CONSULT

1. Turn ignition switch ON and select "DATA MONITOR" mode with CONSULT.
2. Start engine and warm it up to normal operating temperature.
3. Accelerate the vehicle from 0 to 88 km/h (0 to 55 MPH) under the following conditions:

#### CAUTION:

Always drive at a safe speed.

#### NOTE:

- Accelerate with the accelerator pedal kept constant.
- The acceleration at engine speed 2,000 and 3,000 rpm allows easy diagnoses.

|                |             |
|----------------|-------------|
| ACCEL SEN 1    | 1.4 – 2.0 V |
| Selector lever | D position  |

4. Check 1st trip DTC.

##### Without CONSULT

1. Start engine and warm it up to normal operating temperature.
2. With selector lever in D position, accelerate the vehicle from 0 to 88 km/h (0 to 55 MPH) under the following conditions:

#### CAUTION:

Always drive at a safe speed.

#### NOTE:

- Accelerate with the accelerator pedal kept constant.
- The acceleration at engine speed 2,000 and 3,000 rpm allows easy diagnoses.

| Accelerator pedal position sensor 1 |          | Ground | Voltage (V) |
|-------------------------------------|----------|--------|-------------|
| Connector                           | Terminal |        |             |
| M153*1                              | 4*1      | Ground | 1.4 – 2.0   |
| M9*2                                | 3*2      |        |             |

\*1: With ICC

# P0106 MANIFOLD ABSOLUTE PRESSURE SENSOR

[VQ37VHR FOR USA AND CANADA]

## < DTC/CIRCUIT DIAGNOSIS >

\*2: Without ICC

3. Check 1st trip DTC.

Is 1st trip DTC detected?

YES >> Go to [EC-218, "Diagnosis Procedure"](#).

NO >> INSPECTION END

## Diagnosis Procedure

INFOID:000000006882889

### 1. CHECK INTAKE SYSTEM

Check the following for connection.

- Air duct
- Vacuum hoses
- Intake air passage between air duct and intake manifold.

Is the inspection result normal?

YES >> GO TO 2.

NO >> Repair or replace ground connection.

### 2. CHECK GROUND CONNECTION

1. Turn ignition switch OFF.
2. Check ground connection M95. Refer to Ground Inspection in [GI-47, "Circuit Inspection"](#).

Is the inspection result normal?

YES >> GO TO 3.

NO >> Repair or replace ground connection.

### 3. CHECK MAP SENSOR POWER SUPPLY CIRCUIT

1. Disconnect manifold absolute pressure (MAP) sensor harness connector.
2. Turn ignition switch ON.
3. Check the voltage between MAP sensor harness connector and ground.

| MAP sensor |          | Ground | Voltage (V) |
|------------|----------|--------|-------------|
| Connector  | Terminal |        |             |
| F50        | 1        | Ground | Approx. 5   |

Is the inspection result normal?

YES >> GO TO 4.

NO >> Repair open circuit, short to ground or short to power in harness or connectors.

### 4. CHECK MAP SENSOR GROUND CIRCUIT FOR OPEN AND SHORT

1. Turn ignition switch OFF.
2. Disconnect ECM harness connector.
3. Check the continuity between MAP sensor harness connector and ECM harness connector.

| MAP sensor |          | ECM       |          | Continuity |
|------------|----------|-----------|----------|------------|
| Connector  | Terminal | Connector | Terminal |            |
| F50        | 3        | F102      | 96       | Existed    |

4. Also check harness for short to ground and power.

Is the inspection result normal?

YES >> GO TO 5.

NO >> Repair open circuit, short to ground or short to power in harness or connectors.

### 5. CHECK MAP SENSOR INPUT SIGNAL CIRCUIT FOR OPEN AND SHORT

1. Check the continuity between MAP sensor harness connector and ECM harness connector.

# P0106 MANIFOLD ABSOLUTE PRESSURE SENSOR

< DTC/CIRCUIT DIAGNOSIS >

[VQ37VHR FOR USA AND CANADA]

| MAP sensor |          | ECM       |          | Continuity |
|------------|----------|-----------|----------|------------|
| Connector  | Terminal | Connector | Terminal |            |
| F50        | 2        | F101      | 38       | Existed    |

2. Also check harness for short to ground and power.

Is the inspection result normal?

YES >> GO TO 6.

NO >> Repair open circuit, short to ground or short to power in harness or connectors.

## 6.CHECK MAP SENSOR

Refer to [EC-219. "Component Inspection"](#).

Is the inspection result normal?

YES >> GO TO 7.

NO >> Replace MAP sensor. Refer to [EM-31. "Exploded View"](#).

## 7.CHECK INTERMITTENT INCIDENT

Refer to [GI-44. "Intermittent Incident"](#).

>> INSPECTION END

## Component Inspection

INFOID:000000006882890

### 1.CHECK MAP SENSOR-I

1. Turn ignition switch OFF.
2. Start engine and warm it up to normal operating temperature.
3. Turn ignition switch OFF, wait at least 5 seconds and then turn ON.
4. Check the voltage between ECM harness connector terminals as follows.

| ECM       |          |           |          |
|-----------|----------|-----------|----------|
| +         |          | -         |          |
| Connector | Terminal | Connector | Terminal |
| F101      | 38       | F102      | 96       |

#### NOTE:

- To avoid the influence of intake manifold vacuum, check the voltage 1 or more minutes past after engine is stopped.
- Because the sensor is absolute pressure sensor, output value may differ depending on atmospheric pressure and altitude.

5. Measure the atmospheric pressure.

#### NOTE:

As the atmospheric pressure described on the synoptic chart is the value at sea level, compensate the pressure with the following chart.

| Altitude (m) | Compensated pressure (hPa) |
|--------------|----------------------------|
| 0            | 0                          |
| 200          | -24                        |
| 400          | -47                        |
| 600          | -70                        |
| 800          | -92                        |
| 1000         | -114                       |
| 1500         | -168                       |
| 2000         | -218                       |

6. Check the manifold absolute pressure sensor value corresponding to the atmospheric pressure.

# P0106 MANIFOLD ABSOLUTE PRESSURE SENSOR

< DTC/CIRCUIT DIAGNOSIS >

[VQ37VHR FOR USA AND CANADA]

| Atmospheric pressure (hPa) | Voltage (V) |
|----------------------------|-------------|
| 800                        | 3.1 – 3.7   |
| 850                        | 3.3 – 3.9   |
| 900                        | 3.5 – 4.1   |
| 950                        | 3.8 – 4.3   |
| 1000                       | 4.0 – 4.6   |
| 1050                       | 4.2 – 4.8   |

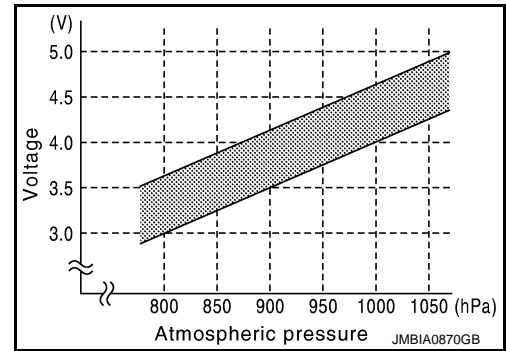

Is the inspection result normal?

YES >> GO TO 2.

NO >> Replace MAP sensor. Refer to [EM-31, "Exploded View"](#).

## 2. CHECK MAP SENSOR-II

1. Start engine and let it idle.
2. Check intake manifold vacuum.
3. Check the voltage between ECM harness connector terminals as per the following.

| ECM       |          |           |          |
|-----------|----------|-----------|----------|
| +         |          | -         |          |
| Connector | Terminal | Connector | Terminal |
| F101      | 38       | F102      | 96       |

4. Confirm the difference of the voltage when engine is stopped and at idling is within the values shown in the following chart.

| Intake manifold vacuum [kPA (mmHg)] | Voltage difference (V) |
|-------------------------------------|------------------------|
| -40 (-300)                          | 1.5 – 2.0              |
| -53.3 (-400)                        | 2.0 – 2.6              |
| -66.7 (-500)                        | 2.6 – 3.2              |
| -80 (-600)                          | 3.2 – 3.8              |

Is the inspection result normal?

YES >> INSPECTION END

NO >> Replace MAP sensor. Refer to [EM-31, "Exploded View"](#).

# P010A MANIFOLD ABSOLUTE PRESSURE SENSOR

< DTC/CIRCUIT DIAGNOSIS >

[VQ37VHR FOR USA AND CANADA]

## P010A MANIFOLD ABSOLUTE PRESSURE SENSOR

### DTC Logic

INFOID:000000006882891

#### DTC DETECTION LOGIC

##### NOTE:

If DTC P010A is displayed with DTC P0643, first perform the trouble diagnosis for DTC P0643.  
Refer to [EC-388, "DTC Logic"](#).

| DTC No. | Trouble diagnosis name                    | DTC detecting condition  | Possible cause   |
|---------|---|--|--|
| P010A   | Manifold absolute pressure sensor circuit | <ul style="list-style-type: none"><li>An excessively low voltage from the sensor is sent to ECM.</li><li>An excessively high voltage from the sensor is sent to ECM.</li></ul> | <ul style="list-style-type: none"><li>Harness or connectors (The sensor circuit is open or shorted.)</li><li>Manifold absolute pressure (MAP) sensor</li></ul> |

#### DTC CONFIRMATION PROCEDURE

##### 1. PRECONDITIONING

If DTC Confirmation Procedure has been previously conducted, always perform the following procedure before conducting the next test.

- Turn ignition switch OFF and wait at least 10 seconds.
- Turn ignition switch ON.
- Turn ignition switch OFF and wait at least 10 seconds.

>> GO TO 2.

##### 2. PERFORM DTC CONFIRMATION PROCEDURE

- Start engine and let it idle for 10 seconds.
- Check 1st trip DTC.

Is 1st trip DTC detected?

- YES >> Go to [EC-221, "Diagnosis Procedure"](#).  
NO >> INSPECTION END

#### Diagnosis Procedure

INFOID:000000006882892

##### 1. CHECK GROUND CONNECTION

- Turn ignition switch OFF.
- Check ground connection M95. Refer to Ground Inspection in [GI-47, "Circuit Inspection"](#).

Is the inspection result normal?

- YES >> GO TO 2.  
NO >> Repair or replace ground connection.

##### 2. CHECK MAP SENSOR POWER SUPPLY CIRCUIT

- Disconnect manifold absolute pressure (MAP) sensor harness connector.
- Turn ignition switch ON.
- Check the voltage between MAP sensor harness connector and ground.

| MAP sensor |          | Ground | Voltage (V) |
|------------|----------|--------|-------------|
| Connector  | Terminal |        |             |
| F50        | 1        | Ground | Approx. 5   |

Is the inspection result normal?

- YES >> GO TO 3.  
NO >> Repair open circuit, short to ground or short to power in harness or connectors.

##### 3. CHECK MAP SENSOR GROUND CIRCUIT FOR OPEN AND SHORT

- Turn ignition switch OFF.
- Disconnect ECM harness connector.

# P010A MANIFOLD ABSOLUTE PRESSURE SENSOR

[VQ37VHR FOR USA AND CANADA]

## < DTC/CIRCUIT DIAGNOSIS >

3. Check the continuity between MAP sensor harness connector and ECM harness connector.

| MAP sensor |          | ECM       |          | Continuity |
|------------|----------|-----------|----------|------------|
| Connector  | Terminal | Connector | Terminal |            |
| F50        | 3        | F102      | 96       | Existed    |

4. Also check harness for short to ground and power.

Is the inspection result normal?

YES >> GO TO 4.

NO >> Repair open circuit, short to ground or short to power in harness or connectors.

## 4.CHECK MAP SENSOR INPUT SIGNAL CIRCUIT FOR OPEN AND SHORT

1. Check the continuity between MAP sensor harness connector and ECM harness connector.

| MAP sensor |          | ECM       |          | Continuity |
|------------|----------|-----------|----------|------------|
| Connector  | Terminal | Connector | Terminal |            |
| F50        | 2        | F101      | 38       | Existed    |

2. Also check harness for short to ground and power.

Is the inspection result normal?

YES >> GO TO 5.

NO >> Repair open circuit, short to ground or short to power in harness or connectors.

## 5.CHECK MAP SENSOR

Refer to [EC-222, "Component Inspection"](#).

Is the inspection result normal?

YES >> GO TO 6.

NO >> Replace MAP sensor. Refer to [EM-31, "Exploded View"](#).

## 6.CHECK INTERMITTENT INCIDENT

Refer to [GI-44, "Intermittent Incident"](#).

>> INSPECTION END

## Component Inspection

INFOID:000000006882893

### 1.CHECK MAP SENSOR-I

1. Turn ignition switch OFF.
2. Start engine and warm it up to normal operating temperature.
3. Turn ignition switch OFF, wait at least 5 seconds and then turn ON.
4. Check the voltage between ECM harness connector terminals as follows.

| ECM       |          |           |          |
|-----------|----------|-----------|----------|
| +         |          | -         |          |
| Connector | Terminal | Connector | Terminal |
| F101      | 38       | F102      | 96       |

#### NOTE:

- To avoid the influence of intake manifold vacuum, check the voltage 1 or more minutes past after engine is stopped.
  - Because the sensor is absolute pressure sensor, output value may differ depending on atmospheric pressure and altitude.
5. Measure the atmospheric pressure.

#### NOTE:

As the atmospheric pressure described on the synoptic chart is the value at sea level, compensate the pressure with the following chart.

# P010A MANIFOLD ABSOLUTE PRESSURE SENSOR

< DTC/CIRCUIT DIAGNOSIS >

[VQ37VHR FOR USA AND CANADA]

| Altitude (m) | Compensated pressure (hPa) |
|--------------|----------------------------|
| 0            | 0                          |
| 200          | -24                        |
| 400          | -47                        |
| 600          | -70                        |
| 800          | -92                        |
| 1000         | -114                       |
| 1500         | -168                       |
| 2000         | -218                       |

6. Check the manifold absolute pressure sensor value corresponding to the atmospheric pressure.

| Atmospheric pressure (hPa) | Voltage (V) |
|----------------------------|-------------|
| 800                        | 3.1 – 3.7   |
| 850                        | 3.3 – 3.9   |
| 900                        | 3.5 – 4.1   |
| 950                        | 3.8 – 4.3   |
| 1000                       | 4.0 – 4.6   |
| 1050                       | 4.2 – 4.8   |

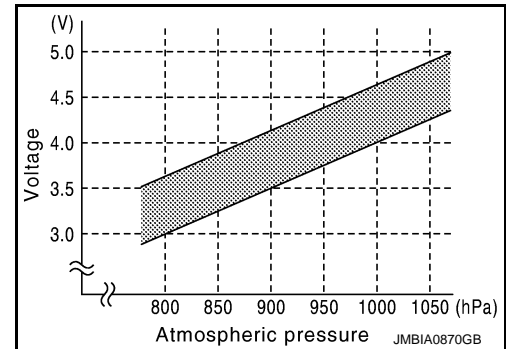

Is the inspection result normal?

YES >> GO TO 2.

NO >> Replace MAP sensor. Refer to [EM-31. "Exploded View"](#).

## 2. CHECK MAP SENSOR-II

1. Start engine and let it idle.
2. Check intake manifold vacuum.
3. Check the voltage between ECM harness connector terminals as per the following.

| ECM       |          |           |          |
|-----------|----------|-----------|----------|
| +         |          | -         |          |
| Connector | Terminal | Connector | Terminal |
| F101      | 38       | F102      | 96       |

4. Confirm the difference of the voltage when engine is stopped and at idling is within the values shown in the following chart.

| Intake manifold vacuum | Voltage difference (V) |
|------------------------|------------------------|
| -40kPa (-300mmHg)      | 1.5 – 2.0              |
| -53.3kPa (-400mmHg)    | 2.0 – 2.6              |
| -66.7kPa (-500mmHg)    | 2.6 – 3.2              |
| -80kPa (-600mmHg)      | 3.2 – 3.8              |

Is the inspection result normal?

YES >> INSPECTION END

NO >> Replace MAP sensor. Refer to [EM-31. "Exploded View"](#).

# P0111 IAT SENSOR

< DTC/CIRCUIT DIAGNOSIS >

[VQ37VHR FOR USA AND CANADA]

## P0111 IAT SENSOR

### DTC Logic

INFOID:000000007202593

### DTC DETECTION LOGIC

| DTC No. | Trouble diagnosis<br>(Trouble diagnosis content)                                      | DTC detecting condition  | Possible cause  |
|---------|---|--|---|
| P0111   | IAT SENSOR 1 B1<br>[Intake air temperature (IAT) sensor<br>circuit range/performance] | The comparison result of signals transmitted to ECM from each temperature sensor (IAT sensor, ECT sensor, FTT sensor, and EOT sensor) shows that the voltage signal of the IAT sensor is higher/lower than that of other temperature sensors when the engine is started with its cold state. | <ul style="list-style-type: none"><li>• Harness or connectors (High or low resistance in the IAT sensor circuit)</li><li>• IAT sensor</li></ul> |

### DTC CONFIRMATION PROCEDURE

#### 1.INSPECTION START

##### Is it necessary to erase permanent DTC?

YES >> GO TO 3.

NO >> GO TO 2.

#### 2.PERFORM COMPONENT FUNCTION CHECK

Perform component function check. Refer to [EC-225, "Component Function Check"](#).

##### **NOTE:**

Use the component function check to check the overall function of the IAT sensor circuit. During this check, a 1st trip DTC might not be confirmed.

##### Is the inspection result normal?

YES >> INSPECTION END

NO >> Proceed to [EC-225, "Diagnosis Procedure"](#).

#### 3.PRECONDITIONING

If DTC CONFIRMATION PROCEDURE has been previously conducted, always perform the following procedure before conducting the next test.

1. Turn ignition switch OFF and wait at least 10 seconds.
2. Turn ignition switch ON.
3. Turn ignition switch OFF and wait at least 10 seconds.

##### **TESTING CONDITION:**

- Before performing the following procedure, do not add fuel.
- Before performing the following procedure, check that fuel level is between 1/4 and 4/4.
- Before performing the following procedure, confirm that battery voltage is 11 V or more at idle.

>> GO TO 4.

#### 4.PERFORM DTC CONFIRMATION PROCEDURE

1. Start engine and let it idle for 60 minutes.
2. Move the vehicle to a cool place.

##### **NOTE:**

Cool the vehicle in an environment of ambient air temperature between  $-10^{\circ}\text{C}$  ( $14^{\circ}\text{F}$ ) and  $35^{\circ}\text{C}$  ( $95^{\circ}\text{F}$ ).

3. Turn ignition switch OFF and soak the vehicle for 12 hours.

##### **CAUTION:**

**Never turn ignition switch ON during soaking.**

##### **NOTE:**

The vehicle must be cooled with the hood open.

4. Start engine and let it idle for 5 minutes or more.

##### **CAUTION:**

**Never turn ignition switch OFF during idling.**

5. Check 1st trip DTC.



# P0111 IAT SENSOR

[VQ37VHR FOR USA AND CANADA]

< DTC/CIRCUIT DIAGNOSIS >

Is 1st trip DTC detected?

- YES >> Proceed to [EC-225, "Diagnosis Procedure"](#).
- NO >> INSPECTION END

A

## Component Function Check

INFOID:000000007202594

EC

### 1.CHECK INTAKE AIR TEMPERATURE (IAT) SENSOR

1. Turn ignition switch OFF.
2. Disconnect mass air flow sensor (bank 1) harness connector.
3. Check resistance between mass air flow sensor (bank 1) terminals as follows.

C

| Terminals | Condition             | Resistance (kΩ)       |
|-----------|-----------------------|-----------------------|
| 1 and 2   | Temperature [°C (°F)] | 25 (77) 1.800 – 2.200 |

D

Is the inspection result normal?

- YES >> GO TO 2.
- NO >> Proceed to [EC-225, "Diagnosis Procedure"](#).

E

### 2.CHECK INTERMITTENT INCIDENT

Check intermittent incident. Refer to [GI-44, "Intermittent Incident"](#).

Is the inspection result normal?

- YES >> INSPECTION END
- NO >> Proceed to [EC-225, "Diagnosis Procedure"](#).

F

G

## Diagnosis Procedure

INFOID:000000007202595

H

### 1.CHECK INTAKE AIR TEMPERATURE (IAT) SENSOR

Check intake air temperature sensor. Refer to [EC-225, "Component Inspection"](#).

Is the inspection result normal?

- YES >> GO TO 2.
- NO >> Replace mass air flow sensor (with intake air temperature sensor) (bank 1). Refer to [EM-29, "Exploded View"](#).

I

J

### 2.CHECK INTERMITTENT INCIDENT

Check intermittent incident. Refer to [GI-44, "Intermittent Incident"](#).

>> INSPECTION END

K

L

## Component Inspection

INFOID:000000007202596

### 1.CHECK INTAKE AIR TEMPERATURE (IAT) SENSOR

1. Turn ignition switch OFF.
2. Disconnect mass air flow sensor (bank 1) harness connector.
3. Check resistance between mass air flow sensor (bank 1) terminals as follows.

M

N

| Terminals | Condition             | Resistance (kΩ)       |
|-----------|-----------------------|-----------------------|
| 1 and 2   | Temperature [°C (°F)] | 25 (77) 1.800 – 2.200 |

O

Is the inspection result normal?

- YES >> INSPECTION END
- NO >> Replace mass air flow sensor (with intake air temperature sensor) (bank 1). Refer to [EM-29, "Exploded View"](#).

P

# P0112, P0113 IAT SENSOR

< DTC/CIRCUIT DIAGNOSIS >

[VQ37VHR FOR USA AND CANADA]

## P0112, P0113 IAT SENSOR

### DTC Logic

INFOID:000000006882894

### DTC DETECTION LOGIC

| DTC No. | Trouble diagnosis name                           | DTC detecting condition                                     | Possible cause   |
|---------|--|---|--|
| P0112   | Intake air temperature sensor circuit low input  | An excessively low voltage from the sensor is sent to ECM.  | • Harness or connectors<br>(The sensor circuit is open or shorted.)<br>• Intake air temperature sensor |
| P0113   | Intake air temperature sensor circuit high input | An excessively high voltage from the sensor is sent to ECM. |  |

### DTC CONFIRMATION PROCEDURE

#### 1. PRECONDITIONING

If DTC Confirmation Procedure has been previously conducted, always perform the following procedure before conducting the next test.

1. Turn ignition switch OFF and wait at least 10 seconds.
2. Turn ignition switch ON.
3. Turn ignition switch OFF and wait at least 10 seconds.

>> GO TO 2.

#### 2. PERFORM DTC CONFIRMATION PROCEDURE

1. Turn ignition switch ON and wait at least 5 seconds.
2. Check 1st trip DTC.

Is 1st trip DTC detected?

- YES >> Go to [EC-226, "Diagnosis Procedure"](#).  
NO >> INSPECTION END

### Diagnosis Procedure

INFOID:000000006882895

#### 1. CHECK GROUND CONNECTION

1. Turn ignition switch OFF.
2. Check ground connection M95. Refer to Ground Inspection in [GI-47, "Circuit Inspection"](#).

Is the inspection result normal?

- YES >> GO TO 2.  
NO >> Repair or replace ground connection.

#### 2. CHECK INTAKE AIR TEMPERATURE SENSOR POWER SUPPLY CIRCUIT

1. Disconnect mass air flow (MAF) sensor (intake air temperature sensor is built-into) harness connector.
2. Turn ignition switch ON.
3. Check the voltage between mass air flow sensor (bank 1) harness connector and ground.

| MAF sensor (bank 1) |          | Ground | Voltage (V) |
|---------------------|----------|--------|-------------|
| Connector           | Terminal |        |             |
| F31                 | 2        | Ground | Approx. 5   |

Is the inspection result normal?

- YES >> GO TO 3.  
NO >> Repair open circuit, short to ground or short to power in harness or connectors.

#### 3. CHECK INTAKE AIR TEMPERATURE SENSOR GROUND CIRCUIT FOR OPEN AND SHORT

1. Turn ignition switch OFF.
2. Disconnect ECM harness connector.
3. Check the continuity between mass air flow sensor (bank 1) harness connector and ECM harness connector.

# P0112, P0113 IAT SENSOR

[VQ37VHR FOR USA AND CANADA]

< DTC/CIRCUIT DIAGNOSIS >

| MAF sensor (bank 1) |          | ECM       |          | Continuity |
|---------------------|----------|-----------|----------|------------|
| Connector           | Terminal | Connector | Terminal |            |
| F31                 | 1        | F102      | 68       | Existed    |

4. Also check harness for short to ground and short to power.

Is the inspection result normal?

YES >> GO TO 4.

NO >> Repair open circuit, short to ground or short to power in harness or connectors.

## 4.CHECK INTAKE AIR TEMPERATURE SENSOR

Refer to [EC-227, "Component Inspection"](#).

Is the inspection result normal?

YES >> GO TO 5.

NO >> Replace mass air flow sensor (with intake air temperature sensor) (bank 1). Refer to [EM-29, "Exploded View"](#).

## 5.CHECK INTERMITTENT INCIDENT

Refer to [GI-44, "Intermittent Incident"](#).

>> INSPECTION END

## Component Inspection

INFOID:000000006882896

## 1.CHECK INTAKE AIR TEMPERATURE SENSOR

1. Turn ignition switch OFF.
2. Disconnect mass air flow sensor (bank 1) harness connector.
3. Check resistance between mass air flow sensor (bank 1) terminals as follows.

| Terminals | Condition             |         | Resistance (kΩ) |
|-----------|-----------------------|---------|-----------------|
| 1 and 2   | Temperature [°C (°F)] | 25 (77) | 1.800 - 2.200   |

Is the inspection result normal?

YES >> INSPECTION END

NO >> Replace mass air flow sensor (with intake air temperature sensor) (bank 1). Refer to [EM-29, "Exploded View"](#).

# P0116 ECT SENSOR

< DTC/CIRCUIT DIAGNOSIS >

[VQ37VHR FOR USA AND CANADA]

## P0116 ECT SENSOR

### DTC Logic

INFOID:000000006882897

#### DTC DETECTION LOGIC

**NOTE:**

If DTC P0116 is displayed with P0117 or P0118, first perform the trouble diagnosis for DTC P0117, P0118. Refer to [EC-231, "DTC Logic"](#).

| DTC No. | Trouble diagnosis<br>(Trouble diagnosis content)                                       | DTC detecting condition  | Possible cause  |
|---------|--|--|---|
| P0116   | ECT SEN/CIRC<br>[Engine coolant temperature (ECT)<br>sensor circuit range/performance] | The comparison result of signals transmitted to ECM from each temperature sensor (IAT sensor, ECT sensor, FTT sensor, and EOT sensor) shows that the voltage signal of the ECT sensor is higher/lower than that of other temperature sensors when the engine is started with its cold state. | <ul style="list-style-type: none"><li>• Harness or connectors (High or low resistance in the ECT sensor circuit)</li><li>• ECT sensor</li></ul> |

#### DTC CONFIRMATION PROCEDURE

##### 1.INSPECTION START

Is it necessary to erase permanent DTC?

- YES >> GO TO 3.
- NO >> GO TO 2.

##### 2.PERFORM COMPONENT FUNCTION CHECK

Perform component function check. Refer to [EC-229, "Component Function Check"](#).

**NOTE:**

Use the component function check to check the overall function of the ECT sensor circuit. During this check, a 1st trip DTC might not be confirmed.

Is the inspection result normal?

- YES >> INSPECTION END
- NO >> Proceed to [EC-229, "Diagnosis Procedure"](#).

##### 3.PRECONDITIONING

If DTC Confirmation Procedure has been previously conducted, always perform the following procedure before conducting the next test.

1. Turn ignition switch OFF and wait at least 10 seconds.
2. Turn ignition switch ON.
3. Turn ignition switch OFF and wait at least 10 seconds.

**TEST CONDITION:**

- Before performing the following procedure, do not add fuel.
- Before performing the following procedure, check that fuel level is between 1/4 and 4/4.
- Before performing the following procedure, confirm that battery voltage is 11 V or more at idle.

>> GO TO 4.

##### 4.PERFORM DTC CONFIRMATION PROCEDURE

1. Start engine and let it idle for 60 minutes.
2. Move the vehicle to a cool place.

**NOTE:**

Cool the vehicle in an environment of ambient air temperature between -10°C (14°F) and 35°C (95°F).

3. Turn ignition switch OFF and soak the vehicle for 12 hours.

**CAUTION:**

**Never turn ignition switch ON during soaking.**

**NOTE:**

The vehicle must be cooled with the hood open.

4. Start engine and let it idle for 5 minutes or more.

# P0116 ECT SENSOR

< DTC/CIRCUIT DIAGNOSIS >

[VQ37VHR FOR USA AND CANADA]

## CAUTION:

Never turn ignition switch OFF during idling.

5. Check 1st trip DTC.

Is 1st trip DTC detected?

- YES >> Proceed to [EC-229, "Diagnosis Procedure"](#).
- NO >> INSPECTION END

## Component Function Check

INFOID:000000007211665

### 1.CHECK ENGINE COOLANT TEMPERATURE (ECT) SENSOR

1. Turn ignition switch OFF.
2. Disconnect ECT sensor harness connector.
3. Remove ECT sensor. Refer to [CO-25, "Exploded View"](#).
4. Check resistance between ECT sensor terminals by heating with hot water as shown in the figure.

| Terminals | Condition             | Resistance (kΩ) |               |
|-----------|-----------------------|-----------------|---------------|
| 1 and 2   | Temperature [°C (°F)] | 20 (68)         | 2.10 - 2.90   |
|           |                       | 50 (122)        | 0.68 - 1.00   |
|           |                       | 90 (194)        | 0.236 - 0.260 |

Is the inspection result normal?

- YES >> GO TO 2.
- NO >> Proceed to [EC-229, "Diagnosis Procedure"](#).

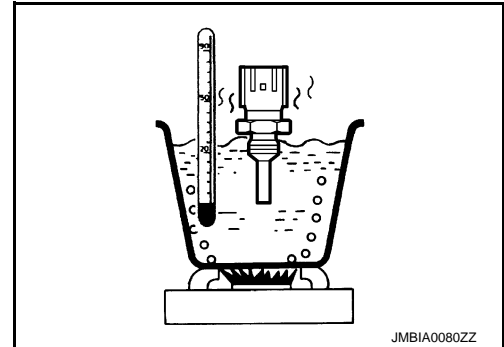

### 2.CHECK INTERMITTENT INCIDENT

Check intermittent incident. Refer to [GI-44, "Intermittent Incident"](#).

Is the inspection result normal?

- YES >> INSPECTION END
- NO >> Proceed to [EC-229, "Diagnosis Procedure"](#).

## Diagnosis Procedure

INFOID:000000007211666

### 1.CHECK ENGINE COOLANT TEMPERATURE (ECT) SENSOR

Check ECT sensor. Refer to [EC-229, "Component Inspection"](#).

Is the inspection result normal?

- OK >> GO TO 2.
- NG >> Replace ECT sensor. Refer to [CO-25, "Exploded View"](#).

### 2.CHECK INTERMITTENT INCIDENT

Check intermittent incident. Refer to [GI-44, "Intermittent Incident"](#).

>> **INSPECTION END**

## Component Inspection

INFOID:000000007211667

### 1.CHECK ENGINE COOLANT TEMPERATURE SENSOR

1. Turn ignition switch OFF.
2. Disconnect engine coolant temperature sensor harness connector.
3. Remove engine coolant temperature sensor. Refer to [CO-25, "Exploded View"](#).

# P0116 ECT SENSOR

[VQ37VHR FOR USA AND CANADA]

## < DTC/CIRCUIT DIAGNOSIS >

4. Check resistance between engine coolant temperature sensor terminals by heating with hot water as shown in the figure.

| Terminals | Condition                                   | Resistance (k $\Omega$ ) |               |
|-----------|---|--------------------------|---------------|
| 1 and 2   | Temperature [ $^{\circ}$ C ( $^{\circ}$ F)] | 20 (68)                  | 2.10 - 2.90   |
|           |   | 50 (122)                 | 0.68 - 1.00   |
|           |   | 90 (194)                 | 0.236 - 0.260 |

Is the inspection result normal?

YES >> INSPECTION END

NO >> Replace engine coolant temperature sensor. Refer to [CO-25, "Exploded View"](#).

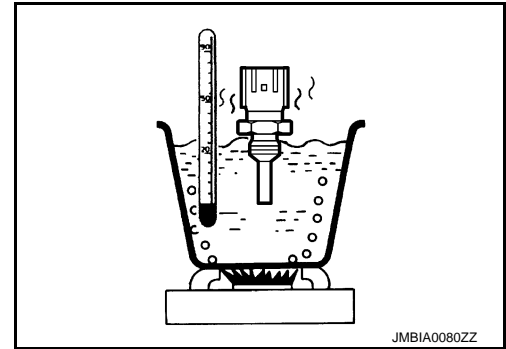

# P0117, P0118 ECT SENSOR

< DTC/CIRCUIT DIAGNOSIS >

[VQ37VHR FOR USA AND CANADA]

## P0117, P0118 ECT SENSOR

### DTC Logic

INFOID:000000006882900

### DTC DETECTION LOGIC

| DTC No. | Trouble Diagnosis Name                               | DTC Detecting Condition                                     | Possible Cause   |
|---------|--|---|--|
| P0117   | Engine coolant temperature sensor circuit low input  | An excessively low voltage from the sensor is sent to ECM.  | <ul style="list-style-type: none"><li>• Harness or connectors (The sensor circuit is open or shorted.)</li><li>• Engine coolant temperature sensor</li></ul> |
| P0118   | Engine coolant temperature sensor circuit high input | An excessively high voltage from the sensor is sent to ECM. |  |

### DTC CONFIRMATION PROCEDURE

#### 1. PRECONDITIONING

If DTC Confirmation Procedure has been previously conducted, always perform the following procedure before conducting the next test.

1. Turn ignition switch OFF and wait at least 10 seconds.
2. Turn ignition switch ON.
3. Turn ignition switch OFF and wait at least 10 seconds.

>> GO TO 2.

#### 2. PERFORM DTC CONFIRMATION PROCEDURE

1. Turn ignition switch ON and wait at least 5 seconds.
2. Check DTC.

Is DTC detected?

- YES >> Go to [EC-231, "Diagnosis Procedure"](#).  
NO >> INSPECTION END

### Diagnosis Procedure

INFOID:000000006882901

#### 1. CHECK GROUND CONNECTION

1. Turn ignition switch OFF.
2. Check ground connection M95. Refer to Ground Inspection in [GI-47, "Circuit Inspection"](#).

Is the inspection result normal?

- YES >> GO TO 2.  
NO >> Repair or replace ground connection.

#### 2. CHECK ECT SENSOR POWER SUPPLY CIRCUIT

1. Disconnect engine coolant temperature (ECT) sensor harness connector.
2. Turn ignition switch ON.
3. Check the voltage between ECT sensor harness connector and ground.

| ECT sensor |          | Ground | Voltage (V) |
|------------|----------|--------|-------------|
| Connector  | Terminal |        |             |
| F17        | 1        | Ground | Approx. 5   |

Is the inspection result normal?

- YES >> GO TO 4.  
NO >> GO TO 3.

#### 3. DETECT MALFUNCTIONING PART

Check the following.

- Harness connectors F106, F107
- Harness for open or short between engine coolant temperature sensor and ECM

# P0117, P0118 ECT SENSOR

[VQ37VHR FOR USA AND CANADA]

< DTC/CIRCUIT DIAGNOSIS >

>> Repair open circuit, short to ground or short to power in harness or connectors.

## 4. CHECK ECT SENSOR GROUND CIRCUIT FOR OPEN AND SHORT

1. Turn ignition switch OFF.
2. Disconnect ECM harness connector.
3. Check the continuity between ECT sensor harness connector and ECM harness connector.

| ECT sensor |          | ECM       |          | Continuity |
|------------|----------|-----------|----------|------------|
| Connector  | Terminal | Connector | Terminal |            |
| F17        | 2        | F102      | 84       | Existed    |

4. Also check harness for short to ground and short to power.

Is the inspection result normal?

YES >> GO TO 5.

NO >> Repair open circuit, short to ground or short to power in harness or connectors.

## 5. CHECK ENGINE COOLANT TEMPERATURE SENSOR

Refer to [EC-232. "Component Inspection"](#).

Is the inspection result normal?

YES >> GO TO 6.

NO >> Replace engine coolant temperature sensor. Refer to [CO-25. "Exploded View"](#).

## 6. CHECK INTERMITTENT INCIDENT

Refer to [GI-44. "Intermittent Incident"](#).

>> INSPECTION END

## Component Inspection

INFOID:000000006882902

## 1. CHECK ENGINE COOLANT TEMPERATURE SENSOR

1. Turn ignition switch OFF.
2. Disconnect engine coolant temperature sensor harness connector.
3. Remove engine coolant temperature sensor. Refer to [CO-25. "Exploded View"](#).
4. Check resistance between engine coolant temperature sensor terminals by heating with hot water as shown in the figure.

| Terminals | Condition           | Resistance (kΩ) |               |
|-----------|---------------------|-----------------|---------------|
| 1 and 2   | Temperature °C (°F) | 20 (68)         | 2.10 - 2.90   |
|           |                     | 50 (122)        | 0.68 - 1.00   |
|           |                     | 90 (194)        | 0.236 - 0.260 |

Is the inspection result normal?

YES >> INSPECTION END

NO >> Replace engine coolant temperature sensor. Refer to [CO-25. "Exploded View"](#).

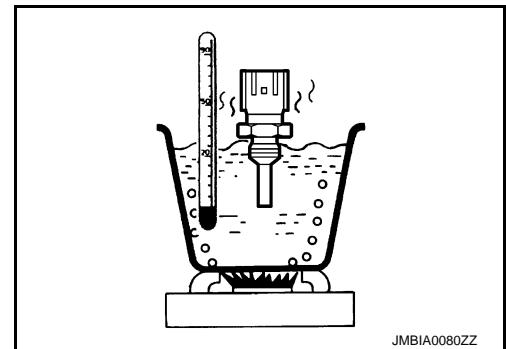



# P0122, P0123, P0227, P0228 TP SENSOR

< DTC/CIRCUIT DIAGNOSIS >

[VQ37VHR FOR USA AND CANADA]

## P0122, P0123, P0227, P0228 TP SENSOR

### DTC Logic

INFOID:000000006882903

#### DTC DETECTION LOGIC

##### NOTE:

If DTC P0122, P0123, P0227 or P0228 is displayed with DTC P0643, first perform the trouble diagnosis for DTC P0643. Refer to [EC-388, "DTC Logic"](#).

| DTC No. | Trouble diagnosis name                                 | DTC detecting condition  | Possible cause  |
|---------|--|--|---|
| P0122   | Throttle position sensor 2 (bank 1) circuit low input  | An excessively low voltage from the TP sensor 2 is sent to ECM.  | • Harness or connectors (TP sensor 2 circuit is open or shorted.)<br>• Electric throttle control actuator (TP sensor 2) |
| P0123   | Throttle position sensor 2 (bank 1) circuit high input | An excessively high voltage from the TP sensor 2 is sent to ECM. |   |
| P0227   | Throttle position sensor 2 (bank 2) circuit low input  | An excessively low voltage from the TP sensor 2 is sent to ECM.  |   |
| P0228   | Throttle position sensor 2 (bank 2) circuit high input | An excessively high voltage from the TP sensor 2 is sent to ECM. |   |

#### DTC CONFIRMATION PROCEDURE

##### 1. PRECONDITIONING

If DTC Confirmation Procedure has been previously conducted, always perform the following procedure before conducting the next test.

1. Turn ignition switch OFF and wait at least 10 seconds.
2. Turn ignition switch ON.
3. Turn ignition switch OFF and wait at least 10 seconds.

##### TESTING CONDITION:

Before performing the following procedure, confirm that battery voltage is more than 10 V at idle.

>> GO TO 2.

##### 2. PERFORM DTC CONFIRMATION PROCEDURE

1. Start engine and let it idle for 1 second.
2. Check DTC.

Is DTC detected?

- YES >> Go to [EC-233, "Diagnosis Procedure"](#).  
NO >> INSPECTION END

#### Diagnosis Procedure

INFOID:000000006882904

##### 1. CHECK GROUND CONNECTION

1. Turn ignition switch OFF.
2. Check ground connection M95. Refer to Ground Inspection in [GI-47, "Circuit Inspection"](#).

Is the inspection result normal?

- YES >> GO TO 2.  
NO >> Repair or replace ground connection.

##### 2. CHECK THROTTLE POSITION SENSOR 2 POWER SUPPLY CIRCUIT

1. Disconnect electric throttle control actuator harness connector.
2. Turn ignition switch ON.
3. Check the voltage between electric throttle control actuator harness connector and ground.

# P0122, P0123, P0227, P0228 TP SENSOR

< DTC/CIRCUIT DIAGNOSIS >

[VQ37VHR FOR USA AND CANADA]

| DTC          | Electric throttle control actuator |           |          | Ground | Voltage (V) |
|--------------|------------------------------------|-----------|----------|--------|-------------|
|              | Bank                               | Connector | Terminal |        |             |
| P0122, P0123 | 1                                  | F67       | 6        | Ground | Approx. 5   |
| P0227, P0228 | 2                                  | F27       | 1        |        |             |

Is the inspection result normal?

YES >> GO TO 3.

NO >> Repair open circuit, short to ground or short to power in harness or connectors.

## 3. CHECK THROTTLE POSITION SENSOR 2 GROUND CIRCUIT FOR OPEN AND SHORT

1. Turn ignition switch OFF.
2. Disconnect ECM harness connector.
3. Check the continuity between electric throttle control actuator harness connector and ECM harness connector.

| DTC          | Electric throttle control actuator |           |          | ECM       |          | Continuity |
|--------------|------------------------------------|-----------|----------|-----------|----------|------------|
|              | Bank                               | Connector | Terminal | Connector | Terminal |            |
| P0122, P0123 | 1                                  | F67       | 3        | F101      | 40       | Existed    |
| P0227, P0228 | 2                                  | F27       | 4        |           | 48       |            |

4. Also check harness for short to ground and short to power.

Is the inspection result normal?

YES >> GO TO 4.

NO >> Repair open circuit, short to ground or short to power in harness or connectors.

## 4. CHECK THROTTLE POSITION SENSOR 2 INPUT SIGNAL CIRCUIT FOR OPEN AND SHORT

1. Check the continuity between electric throttle control actuator harness connector and ECM harness connector.

| DTC          | Electric throttle control actuator |           |          | ECM       |          | Continuity |
|--------------|------------------------------------|-----------|----------|-----------|----------|------------|
|              | Bank                               | Connector | Terminal | Connector | Terminal |            |
| P0122, P0123 | 1                                  | F67       | 5        | F101      | 34       | Existed    |
| P0227, P0228 | 2                                  | F27       | 3        |           | 35       |            |

2. Also check harness for short to ground and short to power.

Is the inspection result normal?

YES >> GO TO 5.

NO >> Repair open circuit, short to ground or short to power in harness or connectors.

## 5. CHECK THROTTLE POSITION SENSOR

Refer to [EC-235, "Component Inspection"](#).

Is the inspection result normal?

YES >> GO TO 7.

NO >> GO TO 6.

## 6. REPLACE ELECTRIC THROTTLE CONTROL ACTUATOR

1. Replace malfunctioning electric throttle control actuator.
2. Go to [EC-235, "Special Repair Requirement"](#).

>> INSPECTION END

## 7. CHECK INTERMITTENT INCIDENT

Refer to [GI-44, "Intermittent Incident"](#).

>> INSPECTION END

# P0122, P0123, P0227, P0228 TP SENSOR

< DTC/CIRCUIT DIAGNOSIS >

[VQ37VHR FOR USA AND CANADA]

## Component Inspection

INFOID:000000006882905

### 1. CHECK THROTTLE POSITION SENSOR

1. Turn ignition switch OFF.
2. Reconnect all harness connectors disconnected.
3. Perform [EC-148, "Work Procedure"](#).
4. Turn ignition switch ON.
5. Set selector lever to D position.
6. Check the voltage between ECM harness connector terminals under the following conditions.

| ECM       |                           |          | Condition       | Voltage (V)    |
|-----------|---------------------------|----------|-----------------|----------------|
| Connector | +                         | -        |                 |                |
|           | Terminal                  | Terminal |                 |                |
| F101      | 30 [TP sensor 1 (bank 1)] | 40       | Fully released  | More than 0.36 |
|           |                           |          | Fully depressed | Less than 4.75 |
|           | 31 [TP sensor 1 (bank 2)] | 48       | Fully released  | More than 0.36 |
|           |                           |          | Fully depressed | Less than 4.75 |
|           | 34 [TP sensor 2 (bank 1)] | 40       | Fully released  | Less than 4.75 |
|           |                           |          | Fully depressed | More than 0.36 |
|           | 35 [TP sensor 2 (bank 2)] | 48       | Fully released  | Less than 4.75 |
|           |                           |          | Fully depressed | More than 0.36 |

Is the inspection result normal?

YES >> INSPECTION END

NO >> GO TO 2.

### 2. REPLACE ELECTRIC THROTTLE CONTROL ACTUATOR

1. Replace malfunctioning electric throttle control actuator.
2. Go to [EC-235, "Special Repair Requirement"](#).

>> INSPECTION END

## Special Repair Requirement

INFOID:000000006882906

### 1. PERFORM THROTTLE VALVE CLOSED POSITION LEARNING

Refer to [EC-148, "Work Procedure"](#)

>> GO TO 2.

### 2. PERFORM IDLE AIR VOLUME LEARNING

Refer to [EC-149, "Work Procedure"](#)

>> END

# P0125 ECT SENSOR

< DTC/CIRCUIT DIAGNOSIS >

[VQ37VHR FOR USA AND CANADA]

## P0125 ECT SENSOR

### DTC Logic

INFOID:000000006882907

#### DTC DETECTION LOGIC

##### NOTE:

If DTC P0125 is displayed with P0117 or P0118, first perform the trouble diagnosis for DTC P0117 or P0118. Refer to [EC-231, "DTC Logic"](#).

| DTC No. | Trouble diagnosis name   | DTC detecting condition  | Possible cause  |
|---------|--|--|---|
| P0125   | Insufficient engine coolant temperature for closed loop fuel control | <ul style="list-style-type: none"><li>• Voltage sent to ECM from the sensor is not practical, even when some time has passed after starting the engine.</li><li>• Engine coolant temperature is insufficient for closed loop fuel control.</li></ul> | <ul style="list-style-type: none"><li>• Harness or connectors (High resistance in the circuit)</li><li>• Engine coolant temperature sensor</li><li>• Thermostat</li></ul> |

#### DTC CONFIRMATION PROCEDURE

##### 1. PRECONDITIONING

If DTC Confirmation Procedure has been previously conducted, always perform the following procedure before conducting the next test.

1. Turn ignition switch OFF and wait at least 10 seconds.
2. Turn ignition switch ON.
3. Turn ignition switch OFF and wait at least 10 seconds.

>> GO TO 2.

##### 2. CHECK ENGINE COOLANT TEMPERATURE SENSOR FUNCTION

1. Turn ignition switch ON.
2. Select "DATA MONITOR" mode with CONSULT.
3. Check that "COOLAN TEMP/S" is above  $-5^{\circ}\text{C}$  ( $23^{\circ}\text{F}$ ).

Is the temperature above  $-5^{\circ}\text{C}$  ( $23^{\circ}\text{F}$ )?

YES >> INSPECTION END

NO >> GO TO 3.

##### 3. PERFORM DTC CONFIRMATION PROCEDURE

1. Start engine and run it for 65 minutes at idle speed.  
If "COOLAN TEMP/S" increases to more than  $-5^{\circ}\text{C}$  ( $23^{\circ}\text{F}$ ) within 65 minutes, stop engine because the test result will be OK.

##### CAUTION:

Be careful not to overheat engine.

2. Check 1st trip DTC.

Is 1st trip DTC detected?

YES >> [EC-236, "Diagnosis Procedure"](#)

NO >> INSPECTION END

#### Diagnosis Procedure

INFOID:000000006882908

##### 1. CHECK GROUND CONNECTION

1. Turn ignition switch OFF.
2. Check ground connection M95. Refer to Ground Inspection in [GI-47, "Circuit Inspection"](#).

Is the inspection result normal?

YES >> GO TO 2.

NO >> Repair or replace ground connection.

##### 2. CHECK ENGINE COOLANT TEMPERATURE SENSOR

Refer to [EC-237, "Component Inspection"](#).

Is the inspection result normal?

# P0125 ECT SENSOR

[VQ37VHR FOR USA AND CANADA]

< DTC/CIRCUIT DIAGNOSIS >

YES >> GO TO 3.

NO >> Replace engine coolant temperature sensor. Refer to [CO-25, "Exploded View"](#).

## 3.CHECK THERMOSTAT OPERATION

When the engine is cold [lower than 70°C (158°F)] condition, grasp lower radiator hose and confirm the engine coolant does not flow.

Is the inspection result normal?

YES >> GO TO 4.

NO >> Repair or replace thermostat. Refer to [CO-23, "Removal and Installation"](#).

## 4.CHECK INTERMITTENT INCIDENT

Refer to [GI-44, "Intermittent Incident"](#).

>> INSPECTION END

## Component Inspection

INFOID:000000006882909

## 1.CHECK ENGINE COOLANT TEMPERATURE SENSOR

1. Turn ignition switch OFF.
2. Disconnect engine coolant temperature sensor harness connector.
3. Remove engine coolant temperature sensor. Refer to [CO-25, "Exploded View"](#).
4. Check resistance between engine coolant temperature sensor terminals by heating with hot water as shown in the figure.

| Terminals | Condition             | Resistance (kΩ) |               |
|-----------|-----------------------|-----------------|---------------|
| 1 and 2   | Temperature [°C (°F)] | 20 (68)         | 2.10 - 2.90   |
|           |                       | 50 (122)        | 0.68 - 1.00   |
|           |                       | 90 (194)        | 0.236 - 0.260 |

Is the inspection result normal?

YES >> INSPECTION END

NO >> Replace engine coolant temperature sensor. Refer to [CO-25, "Exploded View"](#).

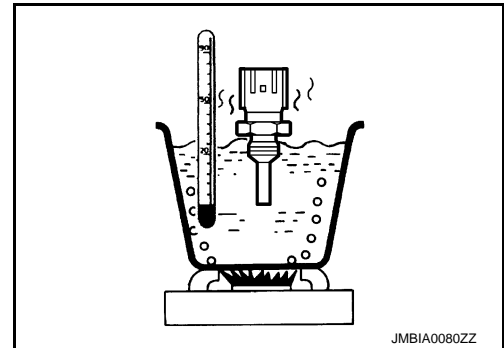

# P0127 IAT SENSOR

< DTC/CIRCUIT DIAGNOSIS >

[VQ37VHR FOR USA AND CANADA]

## P0127 IAT SENSOR

### DTC Logic

INFOID:000000006882910

### DTC DETECTION LOGIC

| DTC No. | Trouble diagnosis name          | DTC detecting condition   | Possible cause  |
|---------|---------------------------------|---|---|
| P0127   | Intake air temperature too high | Rationally incorrect voltage from the sensor is sent to ECM, compared with the voltage signal from engine coolant temperature sensor. | <ul style="list-style-type: none"><li>• Harness or connectors (The sensor circuit is open or shorted)</li><li>• Intake air temperature sensor</li></ul> |

### DTC CONFIRMATION PROCEDURE

#### 1. PRECONDITIONING

If DTC Confirmation Procedure has been previously conducted, always perform the following procedure before conducting the next test.

1. Turn ignition switch OFF and wait at least 10 seconds.
2. Turn ignition switch ON.
3. Turn ignition switch OFF and wait at least 10 seconds.

#### TESTING CONDITION:

**This test may be conducted with the drive wheels lifted in the shop or by driving the vehicle. If a road test is expected to be easier, it is unnecessary to lift the vehicle.**

>> GO TO 2.

#### 2. PERFORM DTC CONFIRMATION PROCEDURE

1. Wait until engine coolant temperature is less than 96°C (205°F)
  - Turn ignition switch ON.
  - Select "DATA MONITOR" mode with CONSULT.
  - Check the engine coolant temperature.
  - If the engine coolant temperature is not less than 96°C (205°F), turn ignition switch OFF and cool down engine.

#### NOTE:

Perform the following steps before engine coolant temperature is above 96°C (205°F).

2. Turn ignition switch ON.
3. Select "DATA MONITOR" mode with CONSULT.
4. Start engine.
5. Hold vehicle speed at more than 70 km/h (43 MPH) for 100 consecutive seconds.

#### CAUTION:

**Always drive vehicle at a safe speed.**

6. Check 1st trip DTC.

Is 1st trip DTC detected?

YES >> Go to [EC-238, "Diagnosis Procedure"](#).

NO >> INSPECTION END

### Diagnosis Procedure

INFOID:000000006882911

#### 1. CHECK GROUND CONNECTION

1. Turn ignition switch OFF.
2. Check ground connection M95. Refer to Ground Inspection in [GI-47, "Circuit Inspection"](#).

Is the inspection result normal?

YES >> GO TO 2.

NO >> Repair or replace ground connection.

#### 2. CHECK INTAKE AIR TEMPERATURE SENSOR

Refer to [EC-239, "Component Inspection"](#).

Is the inspection result normal?

YES >> GO TO 3.

# P0127 IAT SENSOR

[VQ37VHR FOR USA AND CANADA]

< DTC/CIRCUIT DIAGNOSIS >

NO >> Replace mass air flow sensor (with intake air temperature sensor) (bank 1). Refer to [EM-29](#), "[Exploded View](#)".

## 3.CHECK INTERMITTENT INCIDENT

Refer to [GI-44](#), "[Intermittent Incident](#)".

>> INSPECTION END

## Component Inspection

INFOID:000000006882912

## 1.CHECK INTAKE AIR TEMPERATURE SENSOR

1. Turn ignition switch OFF.
2. Disconnect mass air flow sensor (bank 1) harness connector.
3. Check resistance between mass air flow sensor (bank 1) terminals as follows.

| Terminals | Condition             |         | Resistance (kΩ) |
|-----------|-----------------------|---------|-----------------|
| 1 and 2   | Temperature [°C (°F)] | 25 (77) | 1.800 - 2.200   |

Is the inspection result normal?

YES >> INSPECTION END

NO >> Replace mass air flow sensor (with intake air temperature sensor) (bank 1). Refer to [EM-29](#), "[Exploded View](#)".

A  
EC  
C  
D  
E  
F  
G  
H  
I  
J  
K  
L  
M  
N  
O  
P

# P0128 THERMOSTAT FUNCTION

< DTC/CIRCUIT DIAGNOSIS >

[VQ37VHR FOR USA AND CANADA]

## P0128 THERMOSTAT FUNCTION

### DTC Logic

INFOID:000000006882913

#### DTC DETECTION LOGIC

##### NOTE:

If DTC P0128 is displayed with DTC P0300, P0301, P0302, P0303, P0304, P0305 or P0306, first perform the trouble diagnosis for P0300, P0301, P0302, P0303, P0304, P0305, P0306. Refer to [EC-303](#).

Engine coolant temperature has not risen enough to open the thermostat even though the engine has run long enough.

This is due to a leak in the seal or the thermostat being stuck open.

| DTC No. | Trouble diagnosis name | DTC detecting condition  | Possible cause  |
|---------|------------------------|--|---|
| P0128   | Thermostat function    | The engine coolant temperature does not reach to specified temperature even though the engine has run long enough. | <ul style="list-style-type: none"><li>• Thermostat</li><li>• Leakage from sealing portion of thermostat</li><li>• Engine coolant temperature sensor</li></ul> |

#### DTC CONFIRMATION PROCEDURE

##### NOTE:

Never refuel before and during the following procedure.

### 1. PRECONDITIONING-I

If DTC Confirmation Procedure has been previously conducted, always perform the following procedure before conducting the next test.

1. Turn ignition switch OFF and wait at least 10 seconds.
2. Turn ignition switch ON.
3. Turn ignition switch OFF and wait at least 10 seconds.

>> GO TO 2.

### 2. PRECONDITIONING-II

 With CONSULT

1. Turn ignition switch ON.
2. Check the following conditions:

|                     |                      |
|---------------------|----------------------|
| Ambient temperature | -10°C (14°F) or more |
| A/C switch          | OFF                  |
| Blower fan switch   | OFF                  |

3. Select "DATA MONITOR" mode of "ENGINE" using CONSULT.
4. Check the following conditions:

|               |                           |
|---------------|---------------------------|
| COOLAN TEMP/S | -10°C – 52°C (14 – 126°F) |
|---------------|---------------------------|

Is the condition satisfied?

- YES >> GO TO 3.  
NO >> 1. Satisfy the condition.  
2. GO TO 3.

### 3. PERFORM DTC CONFIRMATION PROCEDURE-I

 With CONSULT

1. Start engine.
2. Drive the vehicle until the following condition is satisfied.

##### CAUTION:

**Always drive vehicle at safe speed.**

##### - STEP 1

Drive the vehicle under the conditions instructed below until the difference between "COOLAN TEMP/S" and "FUEL T/TMP SE" becomes at least 25°C (45°F).



# P0128 THERMOSTAT FUNCTION

< DTC/CIRCUIT DIAGNOSIS >

[VQ37VHR FOR USA AND CANADA]

|               |  |
|---------------|--|
| COOLAN TEMP/S | 71°C (159°F) or less   |
| FUEL T/TMP SE | Less than the value calculated by subtracting 25°C (45°F) from "COOLAN TEMP/S".* |

A

EC

C

D

E

F

G

H

I

J

K

L

M

N

O

P

\*: Example

| COOLAN TEMP/S | FUEL T/TMP SE        |
|---------------|----------------------|
| 70°C (158°F)  | 45°C (113°F) or less |
| 65°C (149°F)  | 40°C (104°F) or less |
| 60°C (140°F)  | 35°C (95°F) or less  |

## - STEP 2

Drive the vehicle at 50 km/h (32 MPH) or more with the difference between "COOLAN TEMP/S" and "FUEL T/TMP SE" maintained at 25°C (45°F) or more.

### NOTE:

Keep the accelerator pedal as steady as possible during cruising.

## - STEP 3

Drive the vehicle at 50 km/h (32 MPH) or more until "COOLAN TEMP/S" increases by 6°C (11°F).

### NOTE:

Keep the accelerator pedal as steady as possible during cruising.

Is the condition satisfied?

YES >> GO TO 4.

NO >> GO TO 1.

## 4.PERFORM DTC CONFIRMATION PROCEDURE-II

 With CONSULT

1. Drive the vehicle until the following condition is satisfied.

|               |                      |
|---------------|----------------------|
| COOLAN TEMP/S | 71°C (159°F) or more |
|---------------|----------------------|

### CAUTION:

**Always drive vehicle at safe speed.**

2. Check 1st trip DTC.

Is 1st trip DTC detected?

YES >> Proceed to [EC-241, "Diagnosis Procedure"](#).

NO >> INSPECTION END

## Diagnosis Procedure

INFOID:000000006882914

### 1.CHECK ENGINE COOLANT TEMPERATURE SENSOR

Refer to [EC-241, "Component Inspection"](#).

Is the inspection result normal?

YES >> GO TO 2.

NO >> Replace engine coolant temperature sensor. Refer to [CO-25, "Exploded View"](#).

### 2.CHECK THERMOSTAT

Check thermostat. Refer to [CO-24, "Inspection"](#).

Is the inspection result normal?

YES >> INSPECTION END

NO >> Replace thermostat. Refer to [CO-23, "Exploded View"](#).

## Component Inspection

INFOID:000000006882915

### 1.CHECK ENGINE COOLANT TEMPERATURE SENSOR

1. Turn ignition switch OFF.

2. Disconnect engine coolant temperature sensor harness connector.

3. Remove engine coolant temperature sensor. Refer to [CO-25, "Exploded View"](#).

# P0128 THERMOSTAT FUNCTION

[VQ37VHR FOR USA AND CANADA]

< DTC/CIRCUIT DIAGNOSIS >

4. Check resistance between engine coolant temperature sensor terminals by heating with hot water as shown in the figure.

| Terminals | Condition                                   | Resistance (k $\Omega$ ) |               |
|-----------|---|--------------------------|---------------|
| 1 and 2   | Temperature [ $^{\circ}$ C ( $^{\circ}$ F)] | 20 (68)                  | 2.10 - 2.90   |
|           |   | 50 (122)                 | 0.68 - 1.00   |
|           |   | 90 (194)                 | 0.236 - 0.260 |

Is the inspection result normal?

YES >> INSPECTION END

NO >> Replace engine coolant temperature sensor. Refer to [CO-25, "Exploded View"](#).

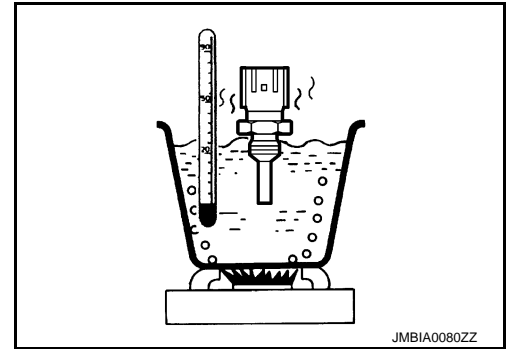

# P0130, P0150 A/F SENSOR 1

< DTC/CIRCUIT DIAGNOSIS >

[VQ37VHR FOR USA AND CANADA]

## P0130, P0150 A/F SENSOR 1

### DTC Logic

INFOID:000000006882916

#### DTC DETECTION LOGIC

To judge malfunctions, the diagnosis checks that the A/F signal computed by ECM from the A/F sensor 1 signal fluctuates according to fuel feedback control.

| DTC No. | Trouble diagnosis name                         | DTC detecting condition |  | Possible Cause   |
|---------|--|-------------------------|--|--|
| P0130   | Air fuel ratio (A/F) sensor 1 (bank 1) circuit | A)                      | The A/F signal computed by ECM from the A/F sensor 1 signal is constantly in a range other than approx. 2.2 V. | • Harness or connectors (The A/F sensor 1 circuit is open or shorted.)<br>• A/F sensor 1 |
|         |  | B)                      | The A/F signal computed by ECM from the A/F sensor 1 signal is constantly approx. 2.2 V.                       |  |
| P0150   | Air fuel ratio (A/F) sensor 1 (bank 2) circuit | A)                      | The A/F signal computed by ECM from the A/F sensor 1 signal is constantly in a range other than approx. 2.2 V. |  |
|         |  | B)                      | The A/F signal computed by ECM from the A/F sensor 1 signal is constantly approx. 2.2 V.                       |  |

#### DTC CONFIRMATION PROCEDURE

##### 1. PRECONDITIONING

If DTC Confirmation Procedure has been previously conducted, always perform the following procedure before conducting the next test.

1. Turn ignition switch OFF and wait at least 10 seconds.
2. Turn ignition switch ON.
3. Turn ignition switch OFF and wait at least 10 seconds.

##### TESTING CONDITION:

Before performing the following procedure, confirm that battery voltage is more than 11 V at idle.

>> GO TO 2.

##### 2. PERFORM DTC CONFIRMATION PROCEDURE FOR MALFUNCTION A

1. Start engine and warm it up to normal operating temperature.
2. Let engine idle for 2 minutes.
3. Check 1st trip DTC.

Is 1st trip DTC detected?

YES >> Go to [EC-245, "Diagnosis Procedure"](#).

NO-1 >> With CONSULT: GO TO 3.

NO-2 >> Without CONSULT: GO TO 7.

##### 3. CHECK AIR FUEL RATIO (A/F) SENSOR 1 FUNCTION

1. Start engine and warm it up to normal operating temperature.
2. Select "A/F SEN1 (B1)" or "A/F SEN1 (B2)" in "DATA MONITOR" mode with CONSULT.
3. Check "A/F SEN1 (B1)" or "A/F SEN1 (B2)" indication.

Does the indication fluctuate around 2.2 V?

YES >> GO TO 4.

NO >> Go to [EC-245, "Diagnosis Procedure"](#).

##### 4. PERFORM DTC CONFIRMATION PROCEDURE FOR MALFUNCTION B-I

1. Select "A/F SEN1 (B1) P1276" (for DTC P0130) or "A/F SEN1 (B2) P1286" (for DTC P0150) of "A/F SEN1" in "DTC WORK SUPPORT" mode with CONSULT.
2. Touch "START".
3. When the following conditions are met, "TESTING" will be displayed on the CONSULT screen.

# P0130, P0150 A/F SENSOR 1

< DTC/CIRCUIT DIAGNOSIS >

[VQ37VHR FOR USA AND CANADA]

|                |                            |
|----------------|----------------------------|
| ENG SPEED      | 1,100 - 3,200 rpm          |
| VHCL SPEED SE  | More than 64 km/h (40 mph) |
| B/FUEL SCHDL   | 1.0 - 8.0 msec             |
| Selector lever | D position                 |

If "TESTING" is not displayed after 20 seconds, retry from step 2.

**CAUTION:**

**Always drive vehicle at a safe speed.**

Is "TESTING" displayed on CONSULT screen?

YES >> GO TO 5.

NO >> Check A/F sensor 1 function again. GO TO 3.

## 5. PERFORM DTC CONFIRMATION PROCEDURE FOR MALFUNCTION B-II

Release accelerator pedal fully.

**NOTE:**

Never apply brake when releasing the accelerator pedal.

Which does "TESTING" change to?

COMPLETED>>GO TO 6.

OUT OF CONDITION>>Retry DTC CONFIRMATION PROCEDURE. GO TO 4.

## 6. PERFORM DTC CONFIRMATION PROCEDURE FOR MALFUNCTION B-III

Touch "SELF-DIAG RESULT".

Which is displayed on CONSULT screen?

OK >> INSPECTION END

NG >> Go to [EC-245, "Diagnosis Procedure"](#).

## 7. PERFORM COMPONENT FUNCTION CHECK FOR MALFUNCTION B

Perform component function check. Refer to [EC-244, "Component Function Check"](#).

**NOTE:**

Use component function check to check the overall function of the A/F sensor 1 circuit. During this check, a 1st trip DTC might not be confirmed.

Is the inspection result normal?

YES >> INSPECTION END

NO >> Go to [EC-245, "Diagnosis Procedure"](#).

## Component Function Check

INFOID:000000006882917

### 1. PERFORM COMPONENT FUNCTION CHECK

 **With GST**

1. Start engine and warm it up to normal operating temperature.
2. Drive the vehicle at a speed of 80 km/h (50 MPH) for a few minutes in the suitable gear position.
3. Shift the selector lever to D position, then release the accelerator pedal fully until the vehicle speed decreases to 50 km/h (30 MPH).

**CAUTION:**

**Always drive vehicle at a safe speed.**

**NOTE:**

Never apply brake when releasing the accelerator pedal.

4. Repeat steps 2 and 3 for five times.
5. Stop the vehicle and turn ignition switch OFF.
6. Turn ignition switch ON.
7. Turn ignition switch OFF and wait at least 10 seconds.
8. Restart engine.
9. Repeat steps 2 and 3 for five times.
10. Stop the vehicle and connect GST to the vehicle.
11. Check 1st trip DTC.

Is 1st trip DTC detected?

# P0130, P0150 A/F SENSOR 1

[VQ37VHR FOR USA AND CANADA]

< DTC/CIRCUIT DIAGNOSIS >

- YES >> Go to [EC-245, "Diagnosis Procedure"](#).  
NO >> INSPECTION END

A

## Diagnosis Procedure

INFOID:000000006882918

### 1. CHECK GROUND CONNECTION

EC

1. Turn ignition switch OFF.
2. Check ground connection M95. Refer to Ground Inspection in [GI-47, "Circuit Inspection"](#).

C

Is the inspection result normal?

- YES >> GO TO 2.  
NO >> Repair or replace ground connection.

D

### 2. CHECK AIR FUEL RATIO (A/F) SENSOR 1 POWER SUPPLY CIRCUIT

1. Disconnect A/F sensor 1 harness connector.
2. Turn ignition switch ON.
3. Check the voltage between A/F sensor 1 harness connector and ground.

E

| DTC   | A/F sensor 1 |           |          | Ground | Voltage         |
|-------|--------------|-----------|----------|--------|-----------------|
|       | Bank         | Connector | Terminal |        |                 |
| P0130 | 1            | F3        | 4        | Ground | Battery voltage |
| P0150 | 2            | F20       | 4        |        |                 |

F

Is the inspection result normal?

- YES >> GO TO 4.  
NO >> GO TO 3.

H

### 3. DETECT MALFUNCTIONING PART

Check the following.

- Harness connectors E20, F40
- IPDM E/R harness connector E7
- 15 A fuse (No. 45)
- Harness for open or short between A/F sensor 1 and fuse

I

>> Repair or replace harness or connectors.

K

### 4. CHECK A/F SENSOR 1 INPUT SIGNAL CIRCUIT FOR OPEN AND SHORT

1. Turn ignition switch OFF.
2. Disconnect ECM harness connector.
3. Check the continuity between A/F sensor 1 harness connector and ECM harness connector.

L

| DTC   | A/F sensor 1 |           |          | ECM       |          | Continuity |
|-------|--------------|-----------|----------|-----------|----------|------------|
|       | Bank         | Connector | Terminal | Connector | Terminal |            |
| P0130 | 1            | F3        | 1        | F102      | 57       | Existed    |
|       |              |           | 2        |           | 61       |            |
| P0150 | 2            | F20       | 1        |           | 65       |            |
|       |              |           | 2        |           | 66       |            |

M

N

O

4. Check the continuity between A/F sensor 1 harness connector and ground, or ECM harness connector and ground.

P

# P0130, P0150 A/F SENSOR 1

< DTC/CIRCUIT DIAGNOSIS >

[VQ37VHR FOR USA AND CANADA]

| DTC   | A/F sensor 1 |           |          | Ground | Continuity  |
|-------|--------------|-----------|----------|--------|-------------|
|       | Bank         | Connector | Terminal |        |             |
| P0130 | 1            | F3        | 1        | Ground | Not existed |
|       |              |           | 2        |        |             |
| P0150 | 2            | F20       | 1        |        |             |
|       |              |           | 2        |        |             |

| DTC   | ECM  |           |          | Ground | Continuity  |
|-------|------|-----------|----------|--------|-------------|
|       | Bank | Connector | Terminal |        |             |
| P0130 | 1    | F102      | 57       | Ground | Not existed |
|       |      |           | 61       |        |             |
| P0150 | 2    |           | 65       |        |             |
|       |      |           | 66       |        |             |

5. Also check harness for short to power.

Is the inspection result normal?

YES >> GO TO 5.

NO >> Repair open circuit, short to ground or short to power in harness or connectors.

## 5.CHECK INTERMITTENT INCIDENT

Perform [GI-44, "Intermittent Incident"](#).

Is the inspection result normal?

YES >> GO TO 6.

NO >> Repair or replace.

## 6.REPLACE AIR FUEL RATIO (A/F) SENSOR 1

Replace malfunctioning air fuel ratio (A/F) sensor 1.

### CAUTION:

- Discard any A/F sensor which has been dropped from a height of more than 0.5 m (19.7 in) onto a hard surface such as a concrete floor; use a new one.
- Before installing new A/F sensor, clean exhaust system threads using Oxygen Sensor Thread Cleaner [commercial service tool (J-43897-18 or J-43897-12)] and approved anti-seize Lubricant (commercial service tool).

>> INSPECTION END

# P0131, P0151 A/F SENSOR 1

< DTC/CIRCUIT DIAGNOSIS >

[VQ37VHR FOR USA AND CANADA]

## P0131, P0151 A/F SENSOR 1

### DTC Logic

INFOID:000000006882919

#### DTC DETECTION LOGIC

To judge malfunctions, the diagnosis checks that the A/F signal computed by ECM from the A/F sensor 1 signal is not inordinately low.

| DTC No. | Trouble diagnosis name                                     | DTC detecting condition  | Possible Cause   |
|---------|--|--|--|
| P0131   | Air fuel ratio (A/F) sensor 1 (bank 1) circuit low voltage | • The A/F signal computed by ECM from the A/F sensor 1 signal is constantly approx. 0 V. | • Harness or connectors (The A/F sensor 1 circuit is open or shorted.)<br>• A/F sensor 1 |
| P0151   | Air fuel ratio (A/F) sensor 1 (bank 2) circuit low voltage |  |  |

#### DTC CONFIRMATION PROCEDURE

##### 1. PRECONDITIONING

If DTC Confirmation Procedure has been previously conducted, always perform the following procedure before conducting the next test.

1. Turn ignition switch OFF and wait at least 10 seconds.
2. Turn ignition switch ON.
3. Turn ignition switch OFF and wait at least 10 seconds.

##### TESTING CONDITION:

Before performing the following procedure, confirm that battery voltage is more than 10.5 V at idle.

>> GO TO 2.

##### 2. CHECK A/F SENSOR FUNCTION

1. Start engine and warm it up to normal operating temperature.
2. Select "A/F SEN1 (B1)" or "A/F SEN1 (B2)" in "DATA MONITOR" mode with CONSULT
3. Check "A/F SEN1 (B1)" or "A/F SEN1 (B2)" indication.

Is the indication constantly approx. 0 V?

YES >> Go to [EC-248. "Diagnosis Procedure"](#).

NO >> GO TO 3.

##### 3. PERFORM DTC CONFIRMATION PROCEDURE

1. Turn ignition switch OFF and wait at least 10 seconds.
2. Turn ignition switch ON.
3. Turn ignition switch OFF and wait at least 10 seconds.
4. Restart engine.
5. Drive and accelerate vehicle to more than 40 km/h (25 MPH) within 20 seconds after restarting engine.

##### CAUTION:

**Always drive vehicle at a safe speed.**

6. Maintain the following conditions for about 20 consecutive seconds.

|                |                            |
|----------------|----------------------------|
| ENG SPEED      | 1,000 - 3,200 rpm          |
| VHCL SPEED SE  | More than 40 km/h (25 mph) |
| B/FUEL SCHDL   | 1.5 - 9.0 msec             |
| Selector lever | Suitable position          |

##### NOTE:

- Keep the accelerator pedal as steady as possible during cruising.
- If this procedure is not completed within 1 minute after restarting engine at step 4, return to step 1.

7. Check 1st trip DTC.

Is 1st trip DTC detected?

YES >> Go to [EC-248. "Diagnosis Procedure"](#).

NO >> INSPECTION END

# P0131, P0151 A/F SENSOR 1

[VQ37VHR FOR USA AND CANADA]

< DTC/CIRCUIT DIAGNOSIS >

## Diagnosis Procedure

INFOID:00000006882920

### 1. CHECK GROUND CONNECTION

1. Turn ignition switch OFF.
2. Check ground connection M95. Refer to Ground Inspection in [GI-47. "Circuit Inspection"](#).

Is the inspection result normal?

- YES >> GO TO 2.  
NO >> Repair or replace ground connection.

### 2. CHECK AIR FUEL RATIO (A/F) SENSOR 1 POWER SUPPLY CIRCUIT

1. Disconnect A/F sensor 1 harness connector.
2. Turn ignition switch ON.
3. Check the voltage between A/F sensor 1 harness connector and ground.

| DTC   | A/F sensor 1 |           |          | Ground | Voltage         |
|-------|--------------|-----------|----------|--------|-----------------|
|       | Bank         | Connector | Terminal |        |                 |
| P0130 | 1            | F3        | 4        | Ground | Battery voltage |
| P0150 | 2            | F20       | 4        |        |                 |

Is the inspection result normal?

- YES >> GO TO 4.  
NO >> GO TO 3.

### 3. DETECT MALFUNCTIONING PART

Check the following.

- Harness connectors E20, F40
- IPDM E/R harness connector E7
- 15 A fuse (No. 45)
- Harness for open or short between A/F sensor 1 and fuse

>> Repair or replace harness or connectors.

### 4. CHECK A/F SENSOR 1 INPUT SIGNAL CIRCUIT FOR OPEN AND SHORT

1. Turn ignition switch OFF.
2. Disconnect ECM harness connector.
3. Check the continuity between A/F sensor 1 harness connector and ECM harness connector.

| DTC   | A/F sensor 1 |           |          | ECM       |          | Continuity |
|-------|--------------|-----------|----------|-----------|----------|------------|
|       | Bank         | Connector | Terminal | Connector | Terminal |            |
| P0130 | 1            | F3        | 1        | F102      | 57       | Existed    |
|       |              |           | 2        |           | 61       |            |
| P0150 | 2            | F20       | 1        |           | 65       |            |
|       |              |           | 2        |           | 66       |            |

4. Check the continuity between A/F sensor 1 harness connector and ground, or ECM harness connector and ground.

| DTC   | A/F sensor 1 |           |          | Ground | Continuity  |
|-------|--------------|-----------|----------|--------|-------------|
|       | Bank         | Connector | Terminal |        |             |
| P0130 | 1            | F3        | 1        | Ground | Not existed |
|       |              |           | 2        |        |             |
| P0150 | 2            | F20       | 1        |        |             |
|       |              |           | 2        |        |             |



# P0131, P0151 A/F SENSOR 1

< DTC/CIRCUIT DIAGNOSIS >

[VQ37VHR FOR USA AND CANADA]

| DTC   | ECM  |           |          | Ground | Continuity  |
|-------|------|-----------|----------|--------|-------------|
|       | Bank | Connector | Terminal |        |             |
| P0130 | 1    | F102      | 57       | Ground | Not existed |
|       |      |           | 61       |        |             |
| P0150 | 2    |           | 65       |        |             |
| 66    |      |           |          |        |             |

5. Also check harness for short to power.

Is the inspection result normal?

YES >> GO TO 5.

NO >> Repair open circuit, short to ground or short to power in harness or connectors.

## 5.CHECK INTERMITTENT INCIDENT

Perform [GI-44. "Intermittent Incident"](#).

Is the inspection result normal?

YES >> GO TO 6.

NO >> Repair or replace.

## 6.REPLACE AIR FUEL RATIO (A/F) SENSOR 1

Replace malfunctioning air fuel ratio (A/F) sensor 1.

### CAUTION:

- Discard any A/F sensor which has been dropped from a height of more than 0.5 m (19.7 in) onto a hard surface such as a concrete floor; use a new one.
- Before installing new A/F sensor, clean exhaust system threads using Oxygen Sensor Thread Cleaner [commercial service tool (J-43897-18 or J-43897-12)] and approved anti-seize Lubricant (commercial service tool).

>> INSPECTION END

A

EC

C

D

E

F

G

H

I

J

K

L

M

N

O

P

# P0132, P0152 A/F SENSOR 1

< DTC/CIRCUIT DIAGNOSIS >

[VQ37VHR FOR USA AND CANADA]

## P0132, P0152 A/F SENSOR 1

### DTC Logic

INFOID:000000006882921

#### DTC DETECTION LOGIC

To judge the malfunction, the diagnosis checks that the A/F signal computed by ECM from the A/F sensor 1 signal is not inordinately high.

| DTC No. | Trouble diagnosis name                                      | DTC detecting condition  | Possible Cause   |
|---------|---|--|--|
| P0132   | Air fuel ratio (A/F) sensor 1 (bank 1) circuit high voltage | • The A/F signal computed by ECM from the A/F sensor 1 signal is constantly approx. 5 V. | • Harness or connectors (The A/F sensor 1 circuit is open or shorted.)<br>• A/F sensor 1 |
| P0152   | Air fuel ratio (A/F) sensor 1 (bank 2) circuit high voltage |  |  |

#### DTC CONFIRMATION PROCEDURE

##### 1. PRECONDITIONING

If DTC Confirmation Procedure has been previously conducted, always perform the following procedure before conducting the next test.

1. Turn ignition switch OFF and wait at least 10 seconds.
2. Turn ignition switch ON.
3. Turn ignition switch OFF and wait at least 10 seconds.

##### TESTING CONDITION:

**Before performing the following procedure, confirm that battery voltage is more than 10.5 V at idle.**

>> GO TO 2.

##### 2. CHECK A/F SENSOR FUNCTION

1. Start engine and warm it up to normal operating temperature.
2. Select "A/F SEN1 (B1)" or "A/F SEN1 (B2)" in "DATA MONITOR" mode with CONSULT.
3. Check "A/F SEN1 (B1)" or "A/F SEN1 (B2)" indication.

Is the indication constantly approx. 5V?

YES >> Go to [EC-251, "Diagnosis Procedure"](#).

NO >> GO TO 3.

##### 3. PERFORM DTC CONFIRMATION PROCEDURE

1. Turn ignition switch OFF and wait at least 10 seconds.
2. Turn ignition switch ON.
3. Turn ignition switch OFF and wait at least 10 seconds.
4. Restart engine.
5. Drive and accelerate vehicle to more than 40 km/h (25 MPH) within 20 seconds after restarting engine.

##### CAUTION:

**Always drive vehicle at a safe speed.**

6. Maintain the following conditions for about 20 consecutive seconds.

|                |                            |
|----------------|----------------------------|
| ENG SPEED      | 1,000 - 3,200 rpm          |
| VHCL SPEED SE  | More than 40 km/h (25 mph) |
| B/FUEL SCHDL   | 1.5 - 9.0 msec             |
| Selector lever | Suitable position          |

##### NOTE:

- Keep the accelerator pedal as steady as possible during cruising.
- If this procedure is not completed within 1 minute after restarting engine at step 4, return to step 1.

7. Check 1st trip DTC.

Is 1st trip DTC detected?

YES >> Go to [EC-251, "Diagnosis Procedure"](#).

NO >> INSPECTION END

# P0132, P0152 A/F SENSOR 1

< DTC/CIRCUIT DIAGNOSIS >

[VQ37VHR FOR USA AND CANADA]

## Diagnosis Procedure

INFOID:000000006882922

### 1. CHECK GROUND CONNECTION

1. Turn ignition switch OFF.
2. Check ground connection M95. Refer to Ground Inspection in [GI-47. "Circuit Inspection"](#).

Is the inspection result normal?

- YES >> GO TO 2.  
 NO >> Repair or replace ground connection.

### 2. CHECK AIR FUEL RATIO (A/F) SENSOR 1 POWER SUPPLY CIRCUIT

1. Disconnect A/F sensor 1 harness connector.
2. Turn ignition switch ON.
3. Check the voltage between A/F sensor 1 harness connector and ground.

| DTC   | A/F sensor 1 |           |          | Ground | Voltage         |
|-------|--------------|-----------|----------|--------|-----------------|
|       | Bank         | Connector | Terminal |        |                 |
| P0130 | 1            | F3        | 4        | Ground | Battery voltage |
| P0150 | 2            | F20       | 4        |        |                 |

Is the inspection result normal?

- YES >> GO TO 4.  
 NO >> GO TO 3.

### 3. DETECT MALFUNCTIONING PART

Check the following.

- Harness connectors E20, F40
- IPDM E/R harness connector E7
- 15 A fuse (No. 45)
- Harness for open or short between A/F sensor 1 and fuse

>> Repair or replace harness or connectors.

### 4. CHECK A/F SENSOR 1 INPUT SIGNAL CIRCUIT FOR OPEN AND SHORT

1. Turn ignition switch OFF.
2. Disconnect ECM harness connector.
3. Check the continuity between A/F sensor 1 harness connector and ECM harness connector.

| DTC   | A/F sensor 1 |           |          | ECM       |          | Continuity |
|-------|--------------|-----------|----------|-----------|----------|------------|
|       | Bank         | Connector | Terminal | Connector | Terminal |            |
| P0130 | 1            | F3        | 1        | F102      | 57       | Existed    |
|       |              |           | 2        |           | 61       |            |
| P0150 | 2            | F20       | 1        |           | 65       |            |
|       |              |           | 2        |           | 66       |            |

4. Check the continuity between A/F sensor 1 harness connector and ground, or ECM harness connector and ground.

| DTC   | A/F sensor 1 |           |          | Ground | Continuity  |
|-------|--------------|-----------|----------|--------|-------------|
|       | Bank         | Connector | Terminal |        |             |
| P0130 | 1            | F3        | 1        | Ground | Not existed |
|       |              |           | 2        |        |             |
| P0150 | 2            | F20       | 1        |        |             |
|       |              |           | 2        |        |             |

# P0132, P0152 A/F SENSOR 1

< DTC/CIRCUIT DIAGNOSIS >

[VQ37VHR FOR USA AND CANADA]

| DTC   | ECM  |           |          | Ground | Continuity  |
|-------|------|-----------|----------|--------|-------------|
|       | Bank | Connector | Terminal |        |             |
| P0130 | 1    | F102      | 57       | Ground | Not existed |
|       |      |           | 61       |        |             |
| P0150 | 2    |           | 65       |        |             |
|       |      |           | 66       |        |             |

5. Also check harness for short to power.

Is the inspection result normal?

YES >> GO TO 5.

NO >> Repair open circuit, short to ground or short to power in harness or connectors.

## 5.CHECK INTERMITTENT INCIDENT

Perform [GI-44. "Intermittent Incident"](#).

Is the inspection result normal?

YES >> GO TO 6.

NO >> Repair or replace.

## 6.REPLACE AIR FUEL RATIO (A/F) SENSOR 1

Replace malfunctioning air fuel ratio (A/F) sensor 1.

### CAUTION:

- Discard any A/F sensor which has been dropped from a height of more than 0.5 m (19.7 in) onto a hard surface such as a concrete floor; use a new one.
- Before installing new A/F sensor, clean exhaust system threads using Oxygen Sensor Thread Cleaner [commercial service tool (J-43897-18 or J-43897-12)] and approved anti-seize Lubricant (commercial service tool).

>> INSPECTION END

# P0133, P0153 A/F SENSOR 1

< DTC/CIRCUIT DIAGNOSIS >

[VQ37VHR FOR USA AND CANADA]

## P0133, P0153 A/F SENSOR 1

### DTC Logic

INFOID:000000006882923

#### DTC DETECTION LOGIC

To judge malfunctions, this diagnosis measures response time of the A/F signal computed by ECM from the A/F sensor 1 signal. The time is compensated by engine operating (speed and load), fuel feedback control constant, and the A/F sensor 1 temperature index. Judgment is based on whether the compensated time (the A/F signal cycling time index) is inordinately long or not.

| DTC No. | Trouble diagnosis name                                       | DTC detecting condition   | Possible Cause   |
|---------|--|---|--|
| P0133   | Air fuel ratio (A/F) sensor 1 (bank 1) circuit slow response | • The response of the A/F signal computed by ECM from A/F sensor 1 signal takes more than the specified time. | • Harness or connectors<br>(The A/F sensor 1 circuit is open or shorted.)<br>• A/F sensor 1<br>• A/F sensor 1 heater<br>• Fuel pressure<br>• Fuel injector<br>• Intake air leaks<br>• Exhaust gas leaks<br>• PCV<br>• Mass air flow sensor |
| P0153   | Air fuel ratio (A/F) sensor 1 (bank 2) circuit slow response |   |  |

#### DTC CONFIRMATION PROCEDURE

##### 1. PRECONDITIONING

If DTC Confirmation Procedure has been previously conducted, always perform the following procedure before conducting the next test.

1. Turn ignition switch OFF and wait at least 10 seconds.
2. Turn ignition switch ON.
3. Turn ignition switch OFF and wait at least 10 seconds.

##### TESTING CONDITION:

**Before performing the following procedure, confirm that battery voltage is more than 11 V at idle.**

Do you have CONSULT?

- YES >> GO TO 2.  
NO >> GO TO 5.

##### 2. PERFORM DTC CONFIRMATION PROCEDURE-I

###### With CONSULT

1. Start engine and warm it up to normal operating temperature.
2. Turn ignition switch OFF and wait at least 10 seconds.
3. Turn ignition switch ON.
4. Turn ignition switch OFF and wait at least 10 seconds.
5. Start engine and keep the engine speed between 3,500 and 4,000 rpm for at least 1 minute under no load.
6. Let engine idle for 1 minute.
7. Select "A/F SEN1(B1) P1278/P1279" (for DTC P0133) or "A/F SEN1(B2) P1288/P1289" (for DTC P0153) of "A/F SEN1" in "DTC WORK SUPPORT" mode with CONSULT.
8. Touch "START".

Is "COMPLETED" displayed on CONSULT screen?

- YES >> GO TO 3  
NO >> GO TO 4.

##### 3. PERFORM DTC CONFIRMATION PROCEDURE-II

Touch "SELF-DIAG RESULT".

Which is displayed on CONSULT screen?

- OK >> INSPECTION END  
NG >> Go to [EC-254, "Diagnosis Procedure"](#).

##### 4. PERFORM DTC CONFIRMATION PROCEDURE-II

1. After perform the following procedure, "TESTING" will be displayed on the CONSULT screen.

# P0133, P0153 A/F SENSOR 1

[VQ37VHR FOR USA AND CANADA]

< DTC/CIRCUIT DIAGNOSIS >

- Increase the engine speed up to about 3,600 rpm and maintain that speed for 10 seconds.
  - Fully release accelerator pedal and then let engine idle for about 10 seconds.
- If “TESTING” is not displayed after 10 seconds, go to [EC-172, "Component Function Check"](#).
2. Wait for about 20 seconds at idle under the condition that “TESTING” is displayed on the CONSULT screen.
  3. Make sure that “TESTING” changes to “COMPLETED”.  
If “TESTING” changed to “OUT OF CONDITION”, go to [EC-172, "Component Function Check"](#).
  4. Touch “SELF-DIAG RESULT”.

Which is displayed on CONSULT screen?

- OK >> INSPECTION END
- NG >> Go to [EC-254, "Diagnosis Procedure"](#).

## 5. CHECK AIR-FUEL RATIO SELF-LEARNING VALUE

 **With GST**

1. Start engine and warm it up to normal operating temperature.
2. Select Service \$01 with GST.
3. Calculate the total value of “Short term fuel trim” and “Long term fuel trim” indications.

Is the total percentage within  $\pm 15\%$ ?

- YES >> GO TO 7.
- NO >> GO TO 6.

## 6. DETECT MALFUNCTIONING PART

Check the following.

- Intake air leaks
- Exhaust gas leaks
- Incorrect fuel pressure
- Lack of fuel
- Fuel injector
- Incorrect PCV hose connection
- PCV valve
- Mass air flow sensor

>> Repair or replace malfunctioning part.

## 7. PERFORM DTC CONFIRMATION PROCEDURE

1. Turn ignition switch OFF and wait at least 10 seconds.
2. Turn ignition switch ON.
3. Turn ignition switch OFF and wait at least 10 seconds.
4. Start engine and keep the engine speed between 3,500 and 4,000 rpm for at least 1 minute under no load.
5. Let engine idle for 1 minute.
6. Increase the engine speed up to about 3,600 rpm and keep it for 10 seconds.
7. Fully release accelerator pedal and then let engine idle for about 1 minute.
8. Check 1st trip DTC.

Is 1st trip DTC detected?

- YES >> Go to [EC-254, "Diagnosis Procedure"](#).
- NO >> INSPECTION END

## Diagnosis Procedure

INFOID:000000006882924

### 1. CHECK GROUND CONNECTION

1. Turn ignition switch OFF.
2. Check ground connection M95. Refer to Ground Inspection in [GI-47, "Circuit Inspection"](#).

Is the inspection result normal?

- YES >> GO TO 2.
- NO >> Repair or replace ground connection.

### 2. RETIGHTEN A/F SENSOR 1

Loosen and retighten the A/F sensor 1. Refer to [EM-36, "Removal and Installation"](#).

# P0133, P0153 A/F SENSOR 1

< DTC/CIRCUIT DIAGNOSIS >

[VQ37VHR FOR USA AND CANADA]

>> GO TO 3.

## 3. CHECK EXHAUST GAS LEAK

1. Start engine and run it at idle.
2. Listen for an exhaust gas leak before three way catalyst 1.

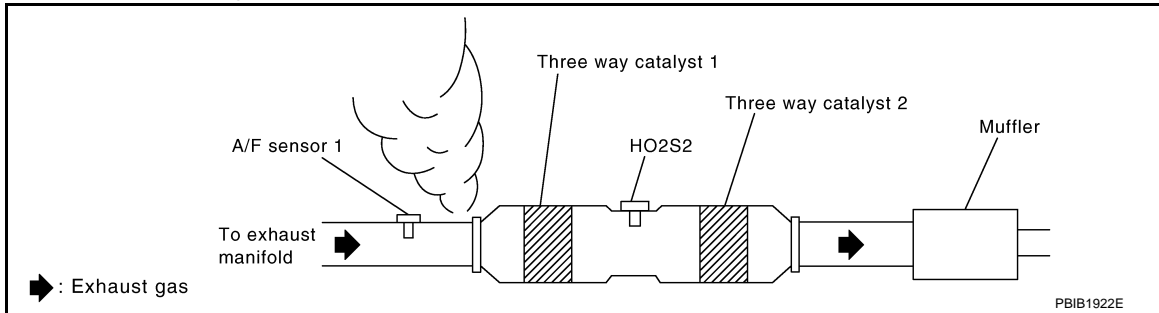

Is exhaust gas leak detected?

- YES >> Repair or replace.  
NO >> GO TO 4.

## 4. CHECK FOR INTAKE AIR LEAK

Listen for an intake air leak after the mass air flow sensor.

Is intake air leak detected?

- YES >> Repair or replace.  
NO >> GO TO 5.

## 5. CLEAR THE MIXTURE RATIO SELF-LEARNING VALUE

1. Clear the mixture ratio self-learning value. Refer to [EC-153. "Work Procedure"](#).
2. Run engine for at least 10 minutes at idle speed.

Is the 1st trip DTC P0171, P172, P0174 or P0175 detected? Is it difficult to start engine?

- YES >> Perform trouble diagnosis for DTC P0171, P0174 or P0172, P0175. Refer to [EC-279. "DTC Logic"](#) or [EC-283. "DTC Logic"](#).  
NO >> GO TO 6.

## 6. CHECK AIR FUEL RATIO (A/F) SENSOR 1 POWER SUPPLY CIRCUIT

1. Disconnect A/F sensor 1 harness connector.
2. Turn ignition switch ON.
3. Check the voltage between A/F sensor 1 harness connector and ground.

| DTC   | A/F sensor 1 |           |          | Ground | Voltage         |
|-------|--------------|-----------|----------|--------|-----------------|
|       | Bank         | Connector | Terminal |        |                 |
| P0133 | 1            | F3        | 4        | Ground | Battery voltage |
| P0153 | 2            | F20       | 4        |        |                 |

Is the inspection result normal?

- YES >> GO TO 8.  
NO >> GO TO 7.

## 7. DETECT MALFUNCTIONING PART

Check the following.

- Harness connectors E20, F40
- IPDM E/R harness connector E7
- 15 A fuse (No. 45)
- Harness for open or short between A/F sensor 1 and fuse

>> Repair or replace harness or connectors.

## 8. CHECK A/F SENSOR 1 INPUT SIGNAL CIRCUIT FOR OPEN AND SHORT

# P0133, P0153 A/F SENSOR 1

[VQ37VHR FOR USA AND CANADA]

## < DTC/CIRCUIT DIAGNOSIS >

1. Turn ignition switch OFF.
2. Disconnect ECM harness connector.
3. Check the continuity between A/F sensor 1 harness connector and ECM harness connector.

| DTC   | A/F sensor 1 |           |          | ECM       |          | Continuity |
|-------|--------------|-----------|----------|-----------|----------|------------|
|       | Bank         | Connector | Terminal | Connector | Terminal |            |
| P0133 | 1            | F3        | 1        | F102      | 57       | Existed    |
|       |              |           | 2        |           | 61       |            |
| P0153 | 2            | F20       | 1        |           | 65       |            |
|       |              |           | 2        |           | 66       |            |

4. Check the continuity between A/F sensor 1 harness connector and ground, or ECM harness connector and ground.

| DTC   | A/F sensor 1 |           |          | Ground | Continuity  |
|-------|--------------|-----------|----------|--------|-------------|
|       | Bank         | Connector | Terminal |        |             |
| P0133 | 1            | F3        | 1        | Ground | Not existed |
|       |              |           | 2        |        |             |
| P0153 | 2            | F20       | 1        |        |             |
|       |              |           | 2        |        |             |

| DTC   | ECM  |           |          | Ground | Continuity  |
|-------|------|-----------|----------|--------|-------------|
|       | Bank | Connector | Terminal |        |             |
| P0133 | 1    | F102      | 57       | Ground | Not existed |
|       |      |           | 61       |        |             |
| P0153 | 2    |           | 65       |        |             |
|       |      |           | 66       |        |             |

5. Also check harness for short to power.

Is the inspection result normal?

YES >> GO TO 9.

NO >> Repair open circuit, short to ground or short to power in harness or connectors.

## 9. CHECK AIR FUEL RATIO (A/F) SENSOR 1 HEATER

Refer to [EC-197, "Component Inspection"](#).

Is the inspection result normal?

YES >> GO TO 10.

NO >> GO TO 13.

## 10. CHECK MASS AIR FLOW SENSOR

Check both mass air flow sensor (bank 1 and bank 2).

Refer to [EC-204, "Component Inspection"](#).

Is the inspection result normal?

YES >> GO TO 11.

NO >> Replace malfunctioning mass air flow sensor. Refer to [EM-29, "Exploded View"](#).

## 11. CHECK PCV VALVE

Refer to [EC-542, "Inspection"](#).

Is the inspection result normal?

YES >> GO TO 12.

NO >> Repair or replace PCV valve. Refer to [EM-49, "Exploded View"](#).

## 12. CHECK INTERMITTENT INCIDENT



# P0133, P0153 A/F SENSOR 1

[VQ37VHR FOR USA AND CANADA]

< DTC/CIRCUIT DIAGNOSIS >

Perform [GI-44. "Intermittent Incident"](#).

Is the inspection result normal?

YES >> GO TO 13.

NO >> Repair or replace.

## 13.REPLACE AIR FUEL RATIO (A/F) SENSOR 1

Replace malfunctioning air fuel ratio (A/F) sensor 1.

### CAUTION:

- Discard any A/F sensor which has been dropped from a height of more than 0.5 m (19.7 in) onto a hard surface such as a concrete floor; use a new one.
- Before installing new A/F sensor, clean exhaust system threads using Oxygen Sensor Thread Cleaner [commercial service tool (J-43897-18 or J-43897-12)] and approved Anti-seize Lubricant (commercial service tool).

>> INSPECTION END

A

EC

C

D

E

F

G

H

I

J

K

L

M

N

O

P

P0137, P0157 HO2S2

DTC Logic

INFOID:000000006882925

DTC DETECTION LOGIC

The heated oxygen sensor 2 has a much longer switching time between rich and lean than the air fuel ratio (A/F) sensor 1. The oxygen storage capacity of the three way catalyst 1 causes the longer switching time. To judge malfunctions of heated oxygen sensor 2, ECM monitors whether the maximum voltage of the sensor is sufficiently high during various driving conditions such as fuel-cut.

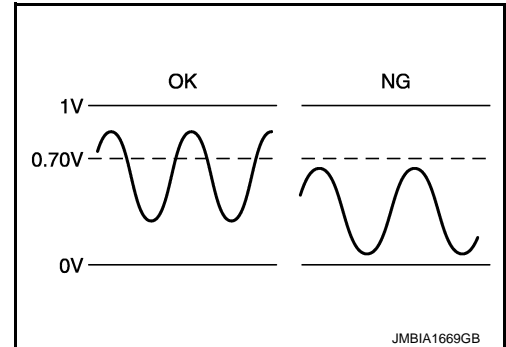

| DTC No. | Trouble diagnosis name                              | DTC detecting condition   | Possible cause  |
|---------|---|---|---|
| P0137   | Heated oxygen sensor 2 (bank 1) circuit low voltage | The maximum voltage from the sensor does not reach the specified voltage. | <ul style="list-style-type: none"> <li>• Harness or connectors (The sensor circuit is open or shorted)</li> <li>• Heated oxygen sensor 2</li> <li>• Fuel pressure</li> <li>• Fuel injector</li> <li>• Intake air leaks</li> </ul> |
| P0157   | Heated oxygen sensor 2 (bank 2) circuit low voltage |   |   |

DTC CONFIRMATION PROCEDURE

1.INSPECTION START

Do you have CONSULT?

Do you have CONSULT?

- YES >> GO TO 2.
- NO >> GO TO 5.

2.PRECONDITIONING

If DTC confirmation Procedure has been previously conducted, always perform the following procedure before conducting the next test.

1. Turn ignition switch OFF and wait at least 10 seconds.
2. Turn ignition switch ON.
3. Turn ignition switch OFF and wait at least 10 seconds.

**TESTING CONDITION:**

For better results, perform “DTC WORK SUPPORT” at a temperature of 0 to 30°C (32 to 86°F).

>> GO TO 3.

3.PERFORM DTC CONFIRMATION PROCEDURE

**Ⓢ With CONSULT**

1. Turn ignition switch ON and select “DATA MONITOR” mode with CONSULT.
2. Start engine and warm it up to the normal operating temperature.
3. Turn ignition switch OFF and wait at least 10 seconds.
4. Turn ignition switch ON.
5. Turn ignition switch OFF and wait at least 10 seconds.
6. Start engine and keep the engine speed between 3,500 and 4,000 rpm for at least 1 minute under no load.
7. Let engine idle for 1 minute.
8. Make sure that “COOLAN TEMP/S” indicates more than 70°C (158°F).  
If not, warm up engine and go to next step when “COOLAN TEMP/S” indication reaches 70°C (158°F).
9. Open engine hood.
10. Select “HO2S2 (B1) P1147” (for DTC P0137) or “HO2S2 (B2) P1167” (for DTC P0157) of “HO2S2” in “DTC WORK SUPPORT” mode with CONSULT.

< DTC/CIRCUIT DIAGNOSIS >

11. Start engine and follow the instruction of CONSULT display.

**NOTE:**

It will take at most 10 minutes until "COMPLETED" is displayed.

12. Touch "SELF-DIAG RESULTS".

Which is displayed on CONSULT screen?

- OK >> INSPECTION END
- NG >> Go to [EC-260. "Diagnosis Procedure"](#).
- CAN NOT BE DIAGNOSED>>GO TO 4.

**4.PERFORM DTC CONFIRMATION PROCEDURE AGAIN**

1. Turn ignition switch OFF and leave the vehicle in a cool place (soak the vehicle).
2. Perform DTC confirmation procedure again.

>> GO TO 3.

**5.PERFORM COMPONENT FUNCTION CHECK**

Perform component function check. Refer to [EC-259. "Component Function Check"](#).

**NOTE:**

Use component function check to check the overall function of the heated oxygen sensor 2 circuit. During this check, a 1st trip DTC might not be confirmed.

Is the inspection result normal?

- YES >> INSPECTION END
- NO >> Go to [EC-260. "Diagnosis Procedure"](#).

**Component Function Check**

INFOID:000000006882926

**1.PERFORM COMPONENT FUNCTION CHECK-I**

**Without CONSULT**

1. Start engine and warm it up to the normal operating temperature.
2. Turn ignition switch OFF and wait at least 10 seconds.
3. Start engine and keep the engine speed between 3,500 and 4,000 rpm for at least 1 minute under no load.
4. Let engine idle for 1 minute.
5. Check the voltage between ECM harness connector terminals under the following condition.

| DTC   | ECM       |          |          | Condition   | Voltage   |
|-------|-----------|----------|----------|---|---|
|       | Connector | +        | -        |   |   |
|       |           | Terminal | Terminal |   |   |
| P0137 | F102      | 76       | 84       | Revving up to 4,000 rpm under no load at least 10 times | The voltage should be above 0.70 V at least once during this procedure. |
| P0157 |           | 80       |          |   |   |

Is the inspection result normal?

- YES >> INSPECTION END
- NO >> GO TO 2.

**2.PERFORM COMPONENT FUNCTION CHECK-II**

Check the voltage between ECM harness connector terminals under the following condition.

| DTC   | ECM       |          |          | Condition                             | Voltage   |
|-------|-----------|----------|----------|---------------------------------------|---|
|       | Connector | +        | -        |                                       |   |
|       |           | Terminal | Terminal |                                       |   |
| P0137 | F102      | 76       | 84       | Keeping engine at idle for 10 minutes | The voltage should be above 0.70 V at least once during this procedure. |
| P0157 |           | 80       |          |                                       |   |

Is the inspection result normal?

- YES >> INSPECTION END
- NO >> GO TO 3.

# P0137, P0157 HO2S2

< DTC/CIRCUIT DIAGNOSIS >

[VQ37VHR FOR USA AND CANADA]

## 3. PERFORM COMPONENT FUNCTION CHECK-III

Check the voltage between ECM harness connector terminals under the following condition.

| DTC            | ECM       |          |          | Condition                                    | Voltage   |
|----------------|-----------|----------|----------|--|---|
|                | Connector | +        | -        |  |   |
|                |           | Terminal | Terminal |  |   |
| P0137<br>P0157 | F102      | 76       | 84       | Coasting from 80 km/h (50 MPH) in D position | The voltage should be above 0.70 V at least once during this procedure. |
|                |           | 80       |          |  |   |

Is the inspection result normal?

- YES >> INSPECTION END
- NO >> Go to [EC-260, "Diagnosis Procedure"](#).

## Diagnosis Procedure

INFOID:000000006882927

### 1. CHECK GROUND CONNECTION

1. Turn ignition switch OFF.
2. Check ground connection M95. Refer to Ground Inspection in [GI-47, "Circuit Inspection"](#).

Is the inspection result normal?

- YES >> GO TO 2.
- NO >> Repair or replace ground connection.

### 2. CLEAR THE MIXTURE RATIO SELF-LEARNING VALUE

1. Clear the mixture ratio self-learning value. Refer to [EC-153, "Work Procedure"](#).
2. Run engine for at least 10 minutes at idle speed.

Is the 1st trip DTC P0171 or P0174 detected? Is it difficult to start engine?

- YES >> Perform trouble diagnosis for DTC P0171 or P0174. Refer to [EC-279, "DTC Logic"](#).
- NO >> GO TO 3.

### 3. CHECK HO2S2 GROUND CIRCUIT FOR OPEN AND SHORT

1. Turn ignition switch OFF.
2. Disconnect heated oxygen sensor 2 (HO2S2) harness connector.
3. Disconnect ECM harness connector.
4. Check the continuity between HO2S2 harness connector and ECM harness connector.

| DTC   | HO2S2 |           |          | ECM       |          | Continuity |
|-------|-------|-----------|----------|-----------|----------|------------|
|       | Bank  | Connector | Terminal | Connector | Terminal |            |
| P0137 | 1     | F54       | 1        | F102      | 84       | Existed    |
| P0157 | 2     | F53       | 1        |           |          |            |

5. Also check harness for short to ground and short to power.

Is the inspection result normal?

- YES >> GO TO 4.
- NO >> Repair open circuit, short to ground or short to power in harness or connectors.

### 4. CHECK HO2S2 INPUT SIGNAL CIRCUIT FOR OPEN AND SHORT

1. Check the continuity between HO2S2 harness connector and ECM harness connector.

| DTC   | HO2S2 |           |          | ECM       |          | Continuity |
|-------|-------|-----------|----------|-----------|----------|------------|
|       | Bank  | Connector | Terminal | Connector | Terminal |            |
| P0137 | 1     | F54       | 4        | F102      | 76       | Existed    |
| P0157 | 2     | F53       | 4        |           | 80       |            |

2. Check the continuity between HO2S2 harness connector and ground, or ECM harness connector and ground.

| DTC   | HO2S2 |           |          | Ground | Continuity  |
|-------|-------|-----------|----------|--------|-------------|
|       | Bank  | Connector | Terminal |        |             |
| P0137 | 1     | F54       | 4        | Ground | Not existed |
| P0157 | 2     | F53       | 4        |        |             |

| DTC   | ECM  |           |          | Ground | Continuity  |
|-------|------|-----------|----------|--------|-------------|
|       | Bank | Connector | Terminal |        |             |
| P0137 | 1    | F102      | 76       | Ground | Not existed |
| P0157 | 2    |           | 80       |        |             |

3. Also check harness for short to power.

Is the inspection result normal?

YES >> GO TO 5.

NO >> Repair open circuit, short to ground or short to power in harness or connectors.

### 5. CHECK HEATED OXYGEN SENSOR 2

Refer to [EC-261, "Component Inspection"](#).

Is the inspection result normal?

YES >> GO TO 7.

NO >> GO TO 6.

### 6. REPLACE HEATED OXYGEN SENSOR 2

Replace malfunctioning heated oxygen sensor 2.

**CAUTION:**

- Discard any heated oxygen sensor which has been dropped from a height of more than 0.5 m (19.7 in) onto a hard surface such as a concrete floor; use a new one.
- Before installing new heated oxygen sensor, clean exhaust system threads using Oxygen Sensor Thread Cleaner [commercial service tool (J-43897-18 or J-43897-12)] and approved Anti-seize Lubricant (commercial service tool).

>> INSPECTION END

### 7. CHECK INTERMITTENT INCIDENT

Refer to [GI-44, "Intermittent Incident"](#).

>> INSPECTION END

## Component Inspection

INFOID:000000006882928

### 1. INSPECTION START

Do you have CONSULT?

Do you have CONSULT?

YES >> GO TO 2.

NO >> GO TO 3.

### 2. CHECK HEATED OXYGEN SENSOR 2

 **With CONSULT**

1. Turn ignition switch ON and select "DATA MONITOR" mode with CONSULT.
2. Start engine and warm it up to the normal operating temperature.
3. Turn ignition switch OFF and wait at least 10 seconds.
4. Start engine and keep the engine speed between 3,500 and 4,000 rpm for at least 1 minute under no load.
5. Let engine idle for 1 minute.
6. Select "FUEL INJECTION" in "ACTIVE TEST" mode, and select "HO2S2 (B1)/(B2)" as the monitor item with CONSULT.

# P0137, P0157 HO2S2

< DTC/CIRCUIT DIAGNOSIS >

[VQ37VHR FOR USA AND CANADA]

7. Check "HO2S2 (B1)/(B2)" at idle speed when adjusting "FUEL INJECTION" to  $\pm 25\%$ .

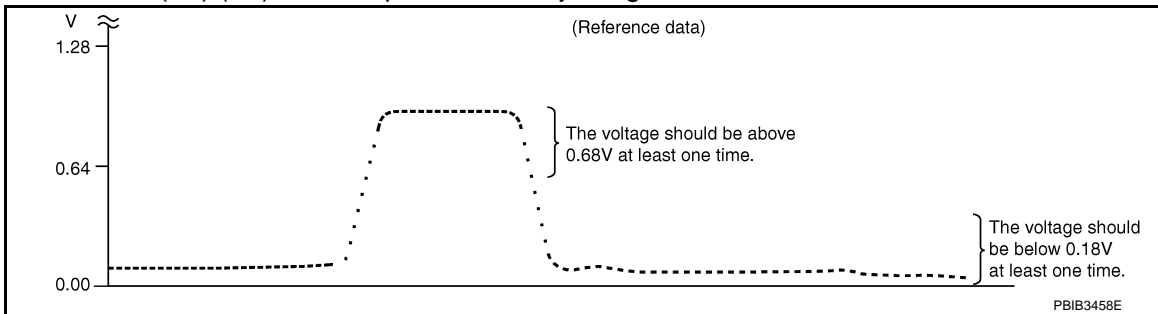

"HO2S2 (B1)/(B2)" should be above 0.70 V at least once when the "FUEL INJECTION" is +25%.

"HO2S2 (B1)/(B2)" should be below 0.18 V at least once when the "FUEL INJECTION" is -25%.

Is the inspection result normal?

YES >> INSPECTION END

NO >> GO TO 6.

## 3. CHECK HEATED OXYGEN SENSOR 2-I

⊗ Without CONSULT

1. Start engine and warm it up to the normal operating temperature.
2. Turn ignition switch OFF and wait at least 10 seconds.
3. Start engine and keep the engine speed between 3,500 and 4,000 rpm for at least 1 minute under no load.
4. Let engine idle for 1 minute.
5. Check the voltage between ECM harness connector terminals under the following condition.

| Connector | ECM                       |          | Condition   | Voltage  |
|-----------|---------------------------|----------|---|--|
|           | +                         | -        |   |  |
|           | Terminal                  | Terminal |   |  |
| F102      | 76<br>[HO2S2<br>(bank 1)] | 84       | Revving up to 4,000 rpm under no load at least 10 times | The voltage should be above 0.70 V at least once during this procedure.<br>The voltage should be below 0.18 V at least once during this procedure. |
|           | 80<br>[HO2S2<br>(bank 2)] |          |   |  |

Is the inspection result normal?

YES >> INSPECTION END

NO >> GO TO 4.

## 4. CHECK HEATED OXYGEN SENSOR 2-II

Check the voltage between ECM harness connector terminals under the following condition.

| Connector | ECM                       |          | Condition                             | Voltage  |
|-----------|---------------------------|----------|---------------------------------------|--|
|           | +                         | -        |                                       |  |
|           | Terminal                  | Terminal |                                       |  |
| F102      | 76<br>[HO2S2<br>(bank 1)] | 84       | Keeping engine at idle for 10 minutes | The voltage should be above 0.70 V at least once during this procedure.<br>The voltage should be below 0.18 V at least once during this procedure. |
|           | 80<br>[HO2S2<br>(bank 2)] |          |                                       |  |

Is the inspection result normal?

YES >> INSPECTION END

NO >> GO TO 5.

## 5. CHECK HEATED OXYGEN SENSOR 2-III

Check the voltage between ECM harness connector terminals under the following condition.

# P0137, P0157 HO2S2

< DTC/CIRCUIT DIAGNOSIS >

[VQ37VHR FOR USA AND CANADA]

| ECM       |                           |          | Condition                                    | Voltage  |
|-----------|---------------------------|----------|--|--|
| Connector | +                         | -        |  |  |
|           | Terminal                  | Terminal |  |  |
| F102      | 76<br>[HO2S2<br>(bank 1)] | 84       | Coasting from 80 km/h (50 MPH) in D position | The voltage should be above 0.70 V at least once during this procedure.<br>The voltage should be below 0.18 V at least once during this procedure. |
|           | 80<br>[HO2S2<br>(bank 2)] |          |  |  |

Is the inspection result normal?

YES >> INSPECTION END

NO >> GO TO 6.

## 6. REPLACE HEATED OXYGEN SENSOR 2

Replace malfunctioning heated oxygen sensor 2.

### CAUTION:

- Discard any heated oxygen sensor which has been dropped from a height of more than 0.5 m (19.7 in) onto a hard surface such as a concrete floor; use a new one.
- Before installing new heated oxygen sensor, clean exhaust system threads using Oxygen Sensor Thread Cleaner [commercial service tool (J-43897-18 or J-43897-12)] and approved Anti-seize Lubricant (commercial service tool).

>> INSPECTION END

A  
EC  
C  
D  
E  
F  
G  
H  
I  
J  
K  
L  
M  
N  
O  
P

P0138, P0158 HO2S2

DTC Logic

INFOID:00000006882929

DTC DETECTION LOGIC

The heated oxygen sensor 2 has a much longer switching time between rich and lean than the air fuel ratio (A/F) sensor 1. The oxygen storage capacity of the three way catalyst 1 causes the longer switching time.

**MALFUNCTION A**

To judge malfunctions of heated oxygen sensor 2, ECM monitors whether the voltage is unusually high during various driving conditions such as fuel cut.

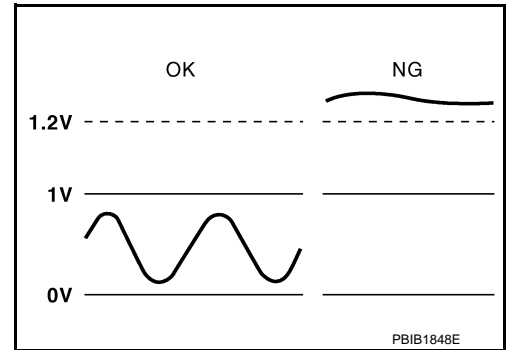

**MALFUNCTION B**

To judge malfunctions of heated oxygen sensor 2, ECM monitors whether the minimum voltage of sensor is sufficiently low during various driving conditions such as fuel cut.

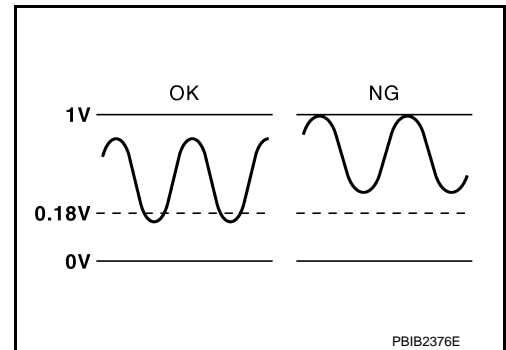

| DTC No. | Trouble diagnosis name                               | DTC detecting condition |  | Possible cause  |
|---------|--|-------------------------|--|---|
| P0138   | Heated oxygen sensor 2 (bank 1) circuit high voltage | A)                      | An excessively high voltage from the sensor is sent to ECM.                  | <ul style="list-style-type: none"> <li>• Harness or connectors (The sensor circuit is open or shorted)</li> <li>• Heated oxygen sensor 2</li> </ul>   |
|         |  | B)                      | The minimum voltage from the sensor is not reached to the specified voltage. | <ul style="list-style-type: none"> <li>• Harness or connectors (The sensor circuit is open or shorted)</li> <li>• Heated oxygen sensor 2</li> <li>• Fuel pressure</li> <li>• Fuel injector</li> </ul> |
| P0158   | Heated oxygen sensor 2 (bank 2) circuit high voltage | A)                      | An excessively high voltage from the sensor is sent to ECM.                  | <ul style="list-style-type: none"> <li>• Harness or connectors (The sensor circuit is open or shorted)</li> <li>• Heated oxygen sensor 2</li> </ul>   |
|         |  | B)                      | The minimum voltage from the sensor is not reached to the specified voltage. | <ul style="list-style-type: none"> <li>• Harness or connectors (The sensor circuit is open or shorted)</li> <li>• Heated oxygen sensor 2</li> <li>• Fuel pressure</li> <li>• Fuel injector</li> </ul> |

DTC CONFIRMATION PROCEDURE

1. PRECONDITIONING

If DTC Confirmation Procedure has been previously conducted, always perform the following procedure before conducting the next test.

1. Turn ignition switch OFF and wait at least 10 seconds.
2. Turn ignition switch ON.
3. Turn ignition switch OFF and wait at least 10 seconds.



>> GO TO 2.

**2. PERFORM DTC CONFIRMATION PROCEDURE FOR MALFUNCTION A**

1. Start engine and warm it up to the normal operating temperature.
2. Turn ignition switch OFF and wait at least 10 seconds.
3. Turn ignition switch ON.
4. Turn ignition switch OFF and wait at least 10 seconds.
5. Start engine and keep the engine speed between 3,500 and 4,000 rpm for at least 1 minute under no load.
6. Let engine idle for 2 minutes.
7. Check 1st trip DTC.

Is 1st trip DTC detected?

YES >> Go to [EC-266, "Diagnosis Procedure"](#).

NO-1 >> With CONSULT: GO TO 3.

NO-2 >> Without CONSULT: GO TO 5.

**3. PERFORM DTC CONFIRMATION PROCEDURE FOR MALFUNCTION B**

**NOTE:**

**For better results, perform "DTC WORK SUPPORT" at a temperature of 0 to 30 °C (32 to 86 °F).**

1. Select "DATA MONITOR" mode with CONSULT.
2. Start engine and warm it up to the normal operating temperature.
3. Turn ignition switch OFF and wait at least 10 seconds.
4. Turn ignition switch ON.
5. Turn ignition switch OFF and wait at least 10 seconds.
6. Start engine and keep the engine speed between 3,500 and 4,000 rpm for at least 1 minute under no load.
7. Let engine idle for 1 minute.
8. Make sure that "COOLAN TEMP/S" indicates more than 70°C (158°F).  
If not, warm up engine and go to next step when "COOLAN TEMP/S" indication reaches 70°C (158°F).
9. Open engine hood.
10. Select "HO2S2 (B1) P1146" (for DTC P0138) or "HO2S2 (B2) P1166" (for DTC P0158) of "HO2S2" in "DTC WORK SUPPORT" mode with CONSULT.
11. Start engine and follow the instruction of CONSULT display.

**NOTE:**

It will take at most 10 minutes until "COMPLETED" is displayed.

12. Touch "SELF-DIAG RESULTS".

Which is displayed on CONSULT screen?

OK >> INSPECTION END

NG >> Go to [EC-266, "Diagnosis Procedure"](#).

CON NOT BE DIAGNOSED>>GO TO 4.

**4. PERFORM DTC CONFIRMATION PROCEDURE FOR MALFUNCTION B AGAIN**

1. Turn ignition switch OFF and leave the vehicle in a cool place (soak the vehicle).
2. Perform DTC confirmation procedure again.

>> GO TO 3.

**5. PERFORM COMPONENT FUNCTION CHECK FOR MALFUNCTION B**

Perform component function check. Refer to [EC-265, "Component Function Check"](#).

**NOTE:**

Use component function check to check the overall function of the heated oxygen sensor 2 circuit. During this check, a 1st trip DTC might not be confirmed.

Is the inspection result normal?

YES >> INSPECTION END

NO >> Go to [EC-266, "Diagnosis Procedure"](#).

**Component Function Check**

INFOID:000000006882930

**1. PERFORM COMPONENT FUNCTION CHECK-I**

< DTC/CIRCUIT DIAGNOSIS >

⊗ Without CONSULT

1. Start engine and warm it up to the normal operating temperature.
2. Turn ignition switch OFF and wait at least 10 seconds.
3. Start engine and keep the engine speed between 3,500 and 4,000 rpm for at least 1 minute under no load.
4. Let engine idle for 1 minute.
5. Check the voltage between ECM harness connector terminals under the following condition.

| DTC   | ECM       |          |          | Condition   | Voltage   |
|-------|-----------|----------|----------|---|---|
|       | Connector | +        | -        |   |   |
|       |           | Terminal | Terminal |   |   |
| P0138 | F102      | 76       | 84       | Revving up to 4,000 rpm under no load at least 10 times | The voltage should be below 0.18 V at least once during this procedure. |
| P0158 |           | 80       |          |   |   |

Is the inspection result normal?

- YES >> INSPECTION END  
 NO >> GO TO 2.

**2.PERFORM COMPONENT FUNCTION CHECK-II**

Check the voltage between ECM harness connector terminals under the following condition.

| DTC   | ECM       |          |          | Condition                             | Voltage   |
|-------|-----------|----------|----------|---------------------------------------|---|
|       | Connector | +        | -        |                                       |   |
|       |           | Terminal | Terminal |                                       |   |
| P0138 | F102      | 76       | 84       | Keeping engine at idle for 10 minutes | The voltage should be below 0.18 V at least once during this procedure. |
| P0158 |           | 80       |          |                                       |   |

Is the inspection result normal?

- YES >> INSPECTION END  
 NO >> GO TO 3.

**3.PERFORM COMPONENT FUNCTION CHECK-III**

Check the voltage between ECM harness connector terminals under the following condition.

| DTC   | ECM       |          |          | Condition                                    | Voltage   |
|-------|-----------|----------|----------|--|---|
|       | Connector | +        | -        |  |   |
|       |           | Terminal | Terminal |  |   |
| P0138 | F102      | 76       | 84       | Coasting from 80 km/h (50 MPH) in D position | The voltage should be below 0.18 V at least once during this procedure. |
| P0158 |           | 80       |          |  |   |

Is the inspection result normal?

- YES >> INSPECTION END  
 NO >> Go to [EC-266. "Diagnosis Procedure"](#).

**Diagnosis Procedure**

INFOID:000000006882931

**1.INSPECTION START**

Confirm the detected malfunction (A or B). Refer to [EC-264. "DTC Logic"](#).

Which malfunction is detected?

- A >> GO TO 2  
 B >> GO TO 9.

**2.CHECK GROUND CONNECTION**

1. Turn ignition switch OFF.
2. Check ground connection M95. Refer to Ground Inspection in [GI-47. "Circuit Inspection"](#).

Is the inspection result normal?

# P0138, P0158 HO2S2

[VQ37VHR FOR USA AND CANADA]

## < DTC/CIRCUIT DIAGNOSIS >

- YES >> GO TO 3.
- NO >> Repair or replace ground connection.

### 3. CHECK HO2S2 GROUND CIRCUIT FOR OPEN AND SHORT

1. Disconnect heated oxygen sensor 2 (HO2S2) harness connector.
2. Disconnect ECM harness connector.
3. Check the continuity between HO2S2 harness connector and ECM harness connector.

| DTC   | HO2S2 |           |          | ECM       |          | Continuity |
|-------|-------|-----------|----------|-----------|----------|------------|
|       | Bank  | Connector | Terminal | Connector | Terminal |            |
| P0138 | 1     | F54       | 1        | F102      | 84       | Existed    |
| P0158 | 2     | F53       | 1        |           |          |            |

4. Also check harness for short to ground and short to power.

#### Is the inspection result normal?

- YES >> GO TO 4.
- NO >> Repair open circuit, short to ground or short to power in harness or connectors.

### 4. CHECK HO2S2 INPUT SIGNAL CIRCUIT FOR OPEN AND SHORT

1. Check the continuity between HO2S2 harness connector and ECM harness connector.

| DTC   | HO2S2 |           |          | ECM       |          | Continuity |
|-------|-------|-----------|----------|-----------|----------|------------|
|       | Bank  | Connector | Terminal | Connector | Terminal |            |
| P0138 | 1     | F54       | 4        | F102      | 76       | Existed    |
| P0158 | 2     | F53       | 4        |           | 80       |            |

2. Check the continuity between HO2S2 harness connector and ground, or ECM harness connector and ground.

| DTC   | HO2S2 |           |          | Ground | Continuity  |
|-------|-------|-----------|----------|--------|-------------|
|       | Bank  | Connector | Terminal |        |             |
| P0138 | 1     | F54       | 4        | Ground | Not existed |
| P0158 | 2     | F53       | 4        |        |             |

| DTC   | ECM  |           |          | Ground | Continuity  |
|-------|------|-----------|----------|--------|-------------|
|       | Bank | Connector | Terminal |        |             |
| P0138 | 1    | F102      | 76       | Ground | Not existed |
| P0158 | 2    |           | 80       |        |             |

3. Also check harness for short to power.

#### Is the inspection result normal?

- YES >> GO TO 5.
- NO >> Repair open circuit, short to ground or short to power in harness or connectors.

### 5. CHECK HO2S2 CONNECTOR FOR WATER

Check connectors for water.

**Water should not exist.**

#### Is the inspection result normal?

- YES >> GO TO 6.
- NO >> Repair or replace harness or connectors.

### 6. CHECK HEATED OXYGEN SENSOR 2

Refer to [EC-269, "Component Inspection"](#).

< DTC/CIRCUIT DIAGNOSIS >

Is the inspection result normal?

- YES >> GO TO 8.
- NO >> GO TO 7.

**7.**REPLACE HEATED OXYGEN SENSOR 2

Replace malfunctioning heated oxygen sensor 2.

**CAUTION:**

- Discard any heated oxygen sensor which has been dropped from a height of more than 0.5 m (19.7 in) onto a hard surface such as a concrete floor; use a new one.
- Before installing new heated oxygen sensor, clean exhaust system threads using Oxygen Sensor Thread Cleaner [commercial service tool (J-43897-18 or J-43897-12)] and approved Anti-seize Lubricant (commercial service tool).

>> INSPECTION END

**8.**CHECK INTERMITTENT INCIDENT

Refer to [GI-44, "Intermittent Incident"](#).

>> INSPECTION END

**9.**CHECK GROUND CONNECTION

1. Turn ignition switch OFF.
2. Check ground connection M95. Refer to Ground Inspection in [GI-47, "Circuit Inspection"](#).

Is the inspection result normal?

- YES >> GO TO 10.
- NO >> Repair or replace ground connection.

**10.**CLEAR THE MIXTURE RATIO SELF-LEARNING VALUE

1. Clear the mixture ratio self-learning value. Refer to [EC-153, "Work Procedure"](#).
2. Run engine for at least 10 minutes at idle speed.

Is the 1st trip DTC P0172 or P0175 detected? Is it difficult to start engine?

- YES >> Perform trouble diagnosis for DTC P0172, P0175. Refer to [EC-283, "DTC Logic"](#).
- NO >> GO TO 11.

**11.**CHECK HO2S2 GROUND CIRCUIT FOR OPEN AND SHORT

1. Turn ignition switch OFF.
2. Disconnect heated oxygen sensor 2 harness connector.
3. Disconnect ECM harness connector.
4. Check the continuity between HO2S2 harness connector and ECM harness connector.

| DTC   | HO2S2 |           |          | ECM       |          | Continuity |
|-------|-------|-----------|----------|-----------|----------|------------|
|       | Bank  | Connector | Terminal | Connector | Terminal |            |
| P0138 | 1     | F54       | 1        | F102      | 84       | Existed    |
| P0158 | 2     | F53       | 1        |           |          |            |

5. Also check harness for short to ground and short to power.

Is the inspection result normal?

- YES >> GO TO 12.
- NO >> Repair open circuit, short to ground or short to power in harness or connectors.

**12.**CHECK HO2S2 INPUT SIGNAL CIRCUIT FOR OPEN AND SHORT

1. Check the continuity between HO2S2 harness connector and ECM harness connector.

| DTC   | HO2S2 |           |          | ECM       |          | Continuity |
|-------|-------|-----------|----------|-----------|----------|------------|
|       | Bank  | Connector | Terminal | Connector | Terminal |            |
| P0138 | 1     | F54       | 4        | F102      | 76       | Existed    |
| P0158 | 2     | F53       | 4        |           | 80       |            |

2. Check the continuity between HO2S2 harness connector or ECM harness connector and ground.

| DTC   | HO2S2 |           |          | Ground | Continuity  |
|-------|-------|-----------|----------|--------|-------------|
|       | Bank  | Connector | Terminal |        |             |
| P0138 | 1     | F54       | 4        | Ground | Not existed |
| P0158 | 2     | F53       | 4        |        |             |

| DTC   | ECM  |           |          | Ground | Continuity  |
|-------|------|-----------|----------|--------|-------------|
|       | Bank | Connector | Terminal |        |             |
| P0138 | 1    | F102      | 76       | Ground | Not existed |
| P0158 | 2    |           | 80       |        |             |

3. Also check harness for short to power.

Is the inspection result normal?

YES >> GO TO 13.

NO >> Repair open circuit, short to ground or short to power in harness or connectors.

### 13. CHECK HEATED OXYGEN SENSOR 2

Refer to [EC-265, "Component Function Check"](#).

Is the inspection result normal?

YES >> GO TO 15.

NO >> GO TO 14.

### 14. REPLACE HEATED OXYGEN SENSOR 2

Replace malfunctioning heated oxygen sensor 2.

**CAUTION:**

- Discard any heated oxygen sensor which has been dropped from a height of more than 0.5 m (19.7 in) onto a hard surface such as a concrete floor; use a new one.
- Before installing new heated oxygen sensor, clean exhaust system threads using Oxygen Sensor Thread Cleaner [commercial service tool (J-43897-18 or J-43897-12)] and approved Anti-seize Lubricant (commercial service tool).

>> INSPECTION END

### 15. CHECK INTERMITTENT INCIDENT

Refer to [GI-44, "Intermittent Incident"](#).

>> INSPECTION END

## Component Inspection

INFOID:000000006882932

### 1. INSPECTION START

Do you have CONSULT?

Do you have CONSULT?

YES >> GO TO 2.

NO >> GO TO 3.

### 2. CHECK HEATED OXYGEN SENSOR 2

 With CONSULT

A  
EC  
C  
D  
E  
F  
G  
H  
I  
J  
K  
L  
M  
N  
O  
P

# P0138, P0158 HO2S2

[VQ37VHR FOR USA AND CANADA]

## < DTC/CIRCUIT DIAGNOSIS >

1. Turn ignition switch ON and select "DATA MONITOR" mode with CONSULT.
2. Start engine and warm it up to the normal operating temperature.
3. Turn ignition switch OFF and wait at least 10 seconds.
4. Start engine and keep the engine speed between 3,500 and 4,000 rpm for at least 1 minute under no load.
5. Let engine idle for 1 minute.
6. Select "FUEL INJECTION" in "ACTIVE TEST" mode, and select "HO2S2 (B1)/(B2)" as the monitor item with CONSULT.
7. Check "HO2S2 (B1)/(B2)" at idle speed when adjusting "FUEL INJECTION" to  $\pm 25\%$ .

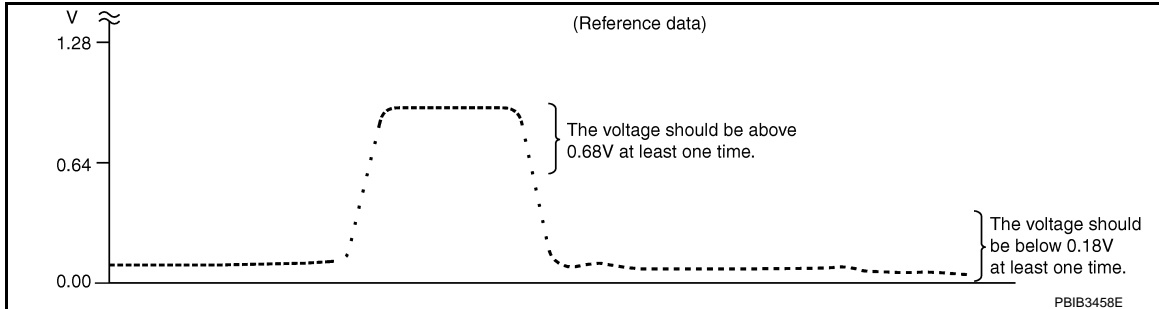

"HO2S2 (B1)/(B2)" should be above 0.70 V at least once when the "FUEL INJECTION" is +25%.  
 "HO2S2 (B1)/(B2)" should be below 0.18 V at least once when the "FUEL INJECTION" is -25%.

Is the inspection result normal?

- YES >> INSPECTION END  
 NO >> GO TO 6.

### 3. CHECK HEATED OXYGEN SENSOR 2-I

#### ⊗ Without CONSULT

1. Start engine and warm it up to the normal operating temperature.
2. Turn ignition switch OFF and wait at least 10 seconds.
3. Start engine and keep the engine speed between 3,500 and 4,000 rpm for at least 1 minute under no load.
4. Let engine idle for 1 minute.
5. Check the voltage between ECM harness connector terminals under the following condition.

| Connector | ECM                       |          | Condition   | Voltage  |
|-----------|---------------------------|----------|---|--|
|           | +                         | -        |   |  |
|           | Terminal                  | Terminal |   |  |
| F102      | 76<br>[HO2S2<br>(bank 1)] | 84       | Revving up to 4,000 rpm under no load at least 10 times | The voltage should be above 0.70 V at least once during this procedure.<br>The voltage should be below 0.18 V at least once during this procedure. |
|           | 80<br>[HO2S2<br>(bank 2)] |          |   |  |

Is the inspection result normal?

- YES >> INSPECTION END  
 NO >> GO TO 4.

### 4. CHECK HEATED OXYGEN SENSOR 2-II

Check the voltage between ECM harness connector terminals under the following condition.

# P0138, P0158 HO2S2

< DTC/CIRCUIT DIAGNOSIS >

[VQ37VHR FOR USA AND CANADA]

| ECM       |                           |          | Condition                             | Voltage  |
|-----------|---------------------------|----------|---------------------------------------|--|
| Connector | +                         | -        |                                       |  |
|           | Terminal                  | Terminal |                                       |  |
| F102      | 76<br>[HO2S2<br>(bank 1)] | 84       | Keeping engine at idle for 10 minutes | The voltage should be above 0.70 V at least once during this procedure.<br>The voltage should be below 0.18 V at least once during this procedure. |
|           | 80<br>[HO2S2<br>(bank 2)] |          |                                       |  |

Is the inspection result normal?

YES >> INSPECTION END  
NO >> GO TO 5.

## 5. CHECK HEATED OXYGEN SENSOR 2-III

Check the voltage between ECM harness connector terminals under the following condition.

| ECM       |                           |          | Condition                                    | Voltage  |
|-----------|---------------------------|----------|--|--|
| Connector | +                         | -        |  |  |
|           | Terminal                  | Terminal |  |  |
| F102      | 76<br>[HO2S2<br>(bank 1)] | 84       | Coasting from 80 km/h (50 MPH) in D position | The voltage should be above 0.70 V at least once during this procedure.<br>The voltage should be below 0.18 V at least once during this procedure. |
|           | 80<br>[HO2S2<br>(bank 2)] |          |  |  |

Is the inspection result normal?

YES >> INSPECTION END  
NO >> GO TO 6.

## 6. REPLACE HEATED OXYGEN SENSOR 2

Replace malfunctioning heated oxygen sensor 2.

### CAUTION:

- Discard any heated oxygen sensor which has been dropped from a height of more than 0.5 m (19.7 in) onto a hard surface such as a concrete floor; use a new one.
- Before installing new heated oxygen sensor, clean exhaust system threads using Oxygen Sensor Thread Cleaner [commercial service tool (J-43897-18 or J-43897-12)] and approved Anti-seize Lubricant (commercial service tool).

>> INSPECTION END

P0139, P0159 HO2S2

DTC Logic

INFOID:000000006882933

DTC DETECTION LOGIC

The heated oxygen sensor 2 has a much longer switching time between rich and lean than the air fuel ratio (A/F) sensor 1. The oxygen storage capacity of the three way catalyst 1 causes the longer switching time. To judge the malfunctions of heated oxygen sensor 2, ECM monitors whether the switching response of the sensor's voltage is faster than specified during various driving conditions such as fuel cut.

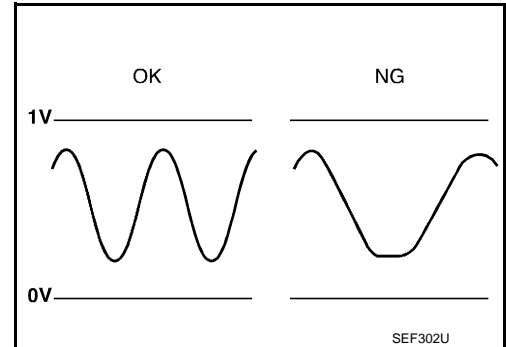

| DTC No. | Trouble diagnosis name                                | DTC detecting condition  | Possible cause   |
|---------|---|--|--|
| P0139   | Heated oxygen sensor 2 (bank 1) circuit slow response | The switching time between rich and lean of a heated oxygen sensor 2 signal delays more than the specified time computed by ECM. | <ul style="list-style-type: none"> <li>• Harness or connectors (The sensor circuit is open or shorted)</li> <li>• Heated oxygen sensor 2</li> <li>• Fuel system</li> <li>• EVAP system</li> <li>• Intake air system</li> </ul> |
| P0159   | Heated oxygen sensor 2 (bank 2) circuit slow response |  |  |

DTC CONFIRMATION PROCEDURE

1. INSPECTION START

Do you have CONSULT?

Do you have CONSULT?

YES >> GO TO 2.

NO >> GO TO 7.

2. PRECONDITIONING

If DTC Confirmation Procedure has been previously conducted, always perform the following procedure before conducting the next test.

1. Turn ignition switch OFF and wait at least 10 seconds.
2. Turn ignition switch ON.
3. Turn ignition switch OFF and wait at least 10 seconds.

**TESTING CONDITION:**

For better results, perform "DTC WORK SUPPORT" at a temperature of 0 to 30°C (32 to 86°F).

>> GO TO 3.

3. PERFORM DTC CONFIRMATION PROCEDURE

**Ⓟ With CONSULT**

1. Turn ignition switch ON and select "DATA MONITOR" mode with CONSULT.
2. Start engine and warm it up to the normal operating temperature.
3. Turn ignition switch OFF and wait at least 10 seconds.
4. Turn ignition switch ON.
5. Turn ignition switch OFF and wait at least 10 seconds.
6. Start engine and keep the engine speed between 3,500 and 4,000 rpm for at least 1 minute under no load.
7. Let engine idle for 1 minute.
8. Make sure that "COOLAN TEMP/S" indicates more than 70°C (158°F).
9. Drive the vehicle in a proper gear at 60 km/h (38MPH) and maintain the speed.

**CAUTION:**

**Always drive vehicle at a safe speed.**

10. Release the accelerator pedal fully at least 5 seconds.



< DTC/CIRCUIT DIAGNOSIS >

**CAUTION:**

- Enable the engine brake.
- Always drive carefully.
- Never apply brake when releasing the accelerator pedal.

11. Repeat step 9 and 10 at least 8 times.
12. Check the following item of "DATA MONITOR".

| DTC   | Data monitor item | Status |
|-------|-------------------|--------|
| P0139 | HO2 S2 DIAG1 (B1) | CMPLT  |
|       | HO2 S2 DIAG2 (B1) |        |
| P0159 | HO2 S2 DIAG1 (B2) |        |
|       | HO2 S2 DIAG2 (B2) |        |

Is "CMPLT" displayed on CONSULT screen?

YES >> GO TO 6.

NO-1: "CMPLT" is not displayed on DIAG 1>>Perform DTC confirmation procedure again.

NO-2: "CMPLT" is not displayed on DIAG 2>>GO TO 4.

**4.PERFORM DTC WORK SUPPORT**

1. Open engine hood.
2. Select "HO2S2 (B1) P0139" or "HO2S2 (B2) P0159" of "HO2S2" in "DTC WORK SUPPORT" mode with CONSULT.
3. Start engine and follow the instruction of CONSULT display.

**NOTE:**

It will take at most 10 minutes until "COMPLETED" is displayed.

Is "COMPLETED" displayed on CONSULT screen?

YES >> GO TO 6.

NO >> GO TO 5.

**5.PERFORM DTC CONFIRMATION PROCEDURE AGAIN**

1. Turn ignition switch OFF and leave the vehicle in a cool place (soak the vehicle).
2. Perform DTC confirmation procedure again.

>> GO TO 3.

**6.PERFORM SELF-DIAGNOSIS**

**Ⓜ With CONSULT**

Perform ECM self-diagnosis.

Is DTC "P0139" or "P0159" detected?

YES >> Proceed to [EC-274, "Diagnosis Procedure"](#).

NO >> INSPECTION END

**7.PERFORM COMPONENT FUNCTION CHECK**

Perform component function check. Refer to [EC-273, "Component Function Check"](#).

**NOTE:**

Use component function check to check the overall function of the heated oxygen sensor 2 circuit. During this check, a 1st trip DTC might not be confirmed.

Is the inspection result normal?

YES >> INSPECTION END

NO >> Proceed to [EC-274, "Diagnosis Procedure"](#).

**Component Function Check**

INFOID:000000006882934

**1.PERFORM COMPONENT FUNCTION CHECK-I**

**Ⓧ Without CONSULT**

1. Start engine and warm it up to the normal operating temperature.
2. Turn ignition switch OFF and wait at least 10 seconds.

# P0139, P0159 HO2S2

[VQ37VHR FOR USA AND CANADA]

## < DTC/CIRCUIT DIAGNOSIS >

3. Start engine and keep the engine speed between 3,500 and 4,000 rpm for at least 1 minute under no load.
4. Let engine idle for 1 minute.
5. Check the voltage between ECM harness connector terminals under the following condition.

| DTC   | ECM       |          |    | Condition   | Voltage  |
|-------|-----------|----------|----|---|--|
|       | Connector | Terminal |    |   |  |
|       |           | +        | -  |   |  |
| P0139 | F102      | 76       | 84 | Revving up to 4,000 rpm under no load at least 10 times | A change of voltage should be more than 0.08 V for 1 second during this procedure. |
| P0159 |           | 80       |    |   |  |

Is the inspection result normal?

YES >> INSPECTION END

NO >> GO TO 2.

## 2.PERFORM COMPONENT FUNCTION CHECK-II

Check the voltage between ECM harness connector terminals under the following condition.

| DTC   | ECM       |          |    | Condition                             | Voltage  |
|-------|-----------|----------|----|---------------------------------------|--|
|       | Connector | Terminal |    |                                       |  |
|       |           | +        | -  |                                       |  |
| P0139 | F102      | 76       | 84 | Keeping engine at idle for 10 minutes | A change of voltage should be more than 0.08 V for 1 second during this procedure. |
| P0159 |           | 80       |    |                                       |  |

Is the inspection result normal?

YES >> INSPECTION END

NO >> GO TO 3.

## 3.PERFORM COMPONENT FUNCTION CHECK-III

Check the voltage between ECM harness connector terminals under the following condition.

| DTC   | ECM       |          |          | Condition  | Voltage  |
|-------|-----------|----------|----------|--|--|
|       | Connector | +        | -        |  |  |
|       |           | Terminal | Terminal |  |  |
| P0139 | F102      | 76       | 84       | Coasting from 80 km/h (50 MPH) on the suitable gear position | A change of voltage should be more than 0.08 V for 1 second during this procedure. |
| P0159 |           | 80       |          |  |  |

Is the inspection result normal?

YES >> INSPECTION END

NO >> Proceed to [EC-274, "Diagnosis Procedure"](#).

## Diagnosis Procedure

INFOID:000000006882935

### 1.CHECK GROUND CONNECTION

1. Turn ignition switch OFF.
2. Check ground connection M95. Refer to Ground Inspection in [GI-47, "Circuit Inspection"](#).

Is the inspection result normal?

YES >> GO TO 2.

NO >> Repair or replace ground connection.

### 2.CLEAR THE MIXTURE RATIO SELF-LEARNING VALUE

1. Clear the mixture ratio self-learning value. Refer to [EC-153, "Work Procedure"](#).
2. Run engine for at least 10 minutes at idle speed.

Is the 1st trip DTC P0171, P0172, P0174 or P0175 detected? Is it difficult to start engine?

YES >> Perform trouble diagnosis for DTC P0171, P0174 or P0172, P0175. Refer to [EC-279, "DTC Logic"](#) or [EC-283, "DTC Logic"](#).

# P0139, P0159 HO2S2

[VQ37VHR FOR USA AND CANADA]

## < DTC/CIRCUIT DIAGNOSIS >

NO >> GO TO 3.

### 3. CHECK HO2S2 GROUND CIRCUIT FOR OPEN AND SHORT

1. Turn ignition switch OFF.
2. Disconnect heated oxygen sensor 2 (HO2S2) harness connector.
3. Disconnect ECM harness connector.
4. Check the continuity between HO2S2 harness connector and ECM harness connector.

| DTC   | HO2S2 |           |          | ECM       |          | Continuity |
|-------|-------|-----------|----------|-----------|----------|------------|
|       | Bank  | Connector | Terminal | Connector | Terminal |            |
| P0139 | 1     | F54       | 1        | F102      | 84       | Existed    |
| P0159 | 2     | F53       | 1        |           |          |            |

5. Also check harness for short to ground and short to power.

Is the inspection result normal?

YES >> GO TO 4.

NO >> Repair open circuit, short to ground or short to power in harness or connectors.

### 4. CHECK HO2S2 INPUT SIGNAL CIRCUIT FOR OPEN AND SHORT

1. Check the continuity between HO2S2 harness connector and ECM harness connector.

| DTC   | HO2S2 |           |          | ECM       |          | Continuity |
|-------|-------|-----------|----------|-----------|----------|------------|
|       | Bank  | Connector | Terminal | Connector | Terminal |            |
| P0139 | 1     | F54       | 4        | F102      | 76       | Existed    |
| P0159 | 2     | F53       | 4        |           | 80       |            |

2. Check the continuity between HO2S2 harness connector and ground, or ECM harness connector and ground.

| DTC   | HO2S2 |           |          | Ground | Continuity  |
|-------|-------|-----------|----------|--------|-------------|
|       | Bank  | Connector | Terminal |        |             |
| P0139 | 1     | F54       | 4        | Ground | Not existed |
| P0159 | 2     | F53       | 4        |        |             |

| DTC   | ECM  |           |          | Ground | Continuity  |
|-------|------|-----------|----------|--------|-------------|
|       | Bank | Connector | Terminal |        |             |
| P0139 | 1    | F102      | 76       | Ground | Not existed |
| P0159 | 2    |           | 80       |        |             |

3. Also check harness for short to power.

Is the inspection result normal?

YES >> GO TO 5.

NO >> Repair open circuit, short to ground or short to power in harness or connectors.

### 5. CHECK HEATED OXYGEN SENSOR 2

Refer to [EC-276, "Component Inspection"](#).

Is the inspection result normal?

YES >> GO TO 7.

NO >> GO TO 6.

### 6. REPLACE HEATED OXYGEN SENSOR 2

Replace malfunctioning heated oxygen sensor 2.

#### **CAUTION:**

- Discard any heated oxygen sensor which has been dropped from a height of more than 0.5 m (19.7 in) onto a hard surface such as a concrete floor; use a new one.

< DTC/CIRCUIT DIAGNOSIS >

- Before installing new heated oxygen sensor, clean exhaust system threads using Oxygen Sensor Thread Cleaner [commercial service tool (J-43897-18 or J-43897-12)] and approved Anti-seize Lubricant (commercial service tool).

>> INSPECTION END

7.CHECK INTERMITTENT INCIDENT

Refer to [GI-44. "Intermittent Incident"](#).

>> INSPECTION END

Component Inspection

INFOID:000000006882936

1.INSPECTION START

Do you have CONSULT?

Do you have CONSULT?

YES >> GO TO 2.

NO >> GO TO 3.

2.CHECK HEATED OXYGEN SENSOR 2

**Ⓟ With CONSULT**

1. Turn ignition switch ON and select "DATA MONITOR" mode with CONSULT.
2. Start engine and warm it up to the normal operating temperature.
3. Turn ignition switch OFF and wait at least 10 seconds.
4. Start engine and keep the engine speed between 3,500 and 4,000 rpm for at least 1 minute under no load.
5. Let engine idle for 1 minute.
6. Select "FUEL INJECTION" in "ACTIVE TEST" mode, and select "HO2S2 (B1)/(B2)" as the monitor item with CONSULT.
7. Check "HO2S2 (B1) / (B2)" at idle speed when adjusting "FUEL INJECTION" to  $\pm 25\%$ .

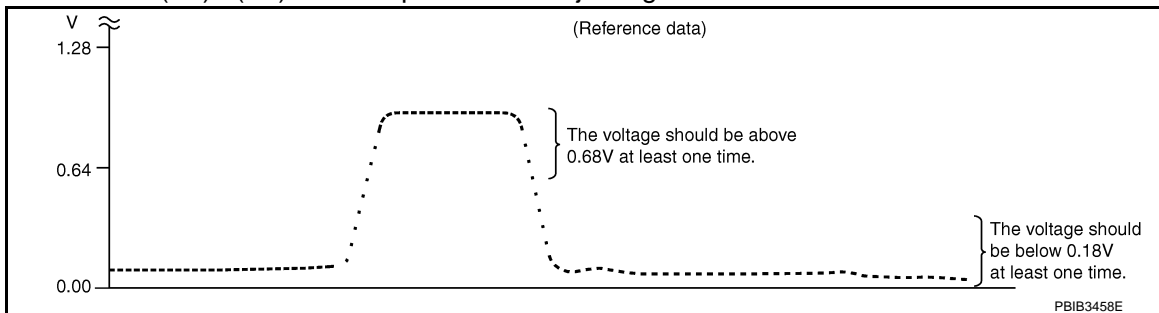

"HO2S2 (B1)/(B2)" should be above 0.70 V at least once when the "FUEL INJECTION" is +25%.

"HO2S2 (B1)/(B2)" should be below 0.18 V at least once when the "FUEL INJECTION" is -25%.

Is the inspection result normal?

YES >> INSPECTION END

NO >> GO TO 6.

3.CHECK HEATED OXYGEN SENSOR 2-I

**Ⓧ Without CONSULT**

1. Start engine and warm it up to the normal operating temperature.
2. Turn ignition switch OFF and wait at least 10 seconds.
3. Start engine and keep the engine speed between 3,500 and 4,000 rpm for at least 1 minute under no load.
4. Let engine idle for 1 minute.
5. Check the voltage between ECM harness connector terminals under the following condition.

| ECM       |                           |          | Condition  | Voltage  |
|-----------|---------------------------|----------|--|--|
| Connector | +                         | -        |  |  |
|           | Terminal                  | Terminal |  |  |
| F102      | 76<br>[HO2S2<br>(bank 1)] | 84       | Revvng up to 4,000 rpm under no load at least 10 times | The voltage should be above 0.70 V at least once during this procedure.<br>The voltage should be below 0.18 V at least once during this procedure. |
|           | 80<br>[HO2S2<br>(bank 2)] |          |  |  |

Is the inspection result normal?

YES >> INSPECTION END  
NO >> GO TO 4.

#### 4.CHECK HEATED OXYGEN SENSOR 2-II

Check the voltage between ECM harness connector terminals under the following condition.

| ECM       |                           |          | Condition                             | Voltage  |
|-----------|---------------------------|----------|---------------------------------------|--|
| Connector | +                         | -        |                                       |  |
|           | Terminal                  | Terminal |                                       |  |
| F102      | 76<br>[HO2S2<br>(bank 1)] | 84       | Keeping engine at idle for 10 minutes | The voltage should be above 0.70 V at least once during this procedure.<br>The voltage should be below 0.18 V at least once during this procedure. |
|           | 80<br>[HO2S2<br>(bank 2)] |          |                                       |  |

Is the inspection result normal?

YES >> INSPECTION END  
NO >> GO TO 5.

#### 5.CHECK HEATED OXYGEN SENSOR 2-III

Check the voltage between ECM harness connector terminals under the following condition.

| ECM       |                           |          | Condition  | Voltage  |
|-----------|---------------------------|----------|--|--|
| Connector | +                         | -        |  |  |
|           | Terminal                  | Terminal |  |  |
| F102      | 76<br>[HO2S2<br>(bank 1)] | 84       | Coasting from 80 km/h (50 MPH) on the suitable gear position | The voltage should be above 0.70 V at least once during this procedure.<br>The voltage should be below 0.18 V at least once during this procedure. |
|           | 80<br>[HO2S2<br>(bank 2)] |          |  |  |

Is the inspection result normal?

YES >> INSPECTION END  
NO >> GO TO 6.

#### 6.REPLACE HEATED OXYGEN SENSOR 2

Replace malfunctioning heated oxygen sensor 2.

**CAUTION:**

- Discard any heated oxygen sensor which has been dropped from a height of more than 0.5 m (19.7 in) onto a hard surface such as a concrete floor; use a new one.
- Before installing new heated oxygen sensor, clean exhaust system threads using Oxygen Sensor Thread Cleaner [commercial service tool (J-43897-18 or J-43897-12)] and approved Anti-seize Lubricant (commercial service tool).

**P0139, P0159 HO2S2**

< DTC/CIRCUIT DIAGNOSIS >

[VQ37VHR FOR USA AND CANADA]

---

>> INSPECTION END

# P0171, P0174 FUEL INJECTION SYSTEM FUNCTION

< DTC/CIRCUIT DIAGNOSIS >

[VQ37VHR FOR USA AND CANADA]

## P0171, P0174 FUEL INJECTION SYSTEM FUNCTION

### DTC Logic

INFOID:000000006882937

#### DTC DETECTION LOGIC

With the Air/Fuel Mixture Ratio Self-Learning Control, the actual mixture ratio can be brought closely to the theoretical mixture ratio based on the mixture ratio feedback signal from A/F sensor 1. The ECM calculates the necessary compensation to correct the offset between the actual and the theoretical ratios.

In case the amount of the compensation value is extremely large (the actual mixture ratio is too lean), the ECM judges the condition as the fuel injection system malfunction and illuminates the MIL (2 trip detection logic).

| Sensor       | Input signal to ECM  | ECM function           | Actuator      |
|--------------|--|------------------------|---------------|
| A/F sensor 1 | Density of oxygen in exhaust gas (Mixture ratio feedback signal) | Fuel injection control | Fuel injector |

| DTC No. | Trouble diagnosis name                  | DTC detecting condition   | Possible cause   |
|---------|---|---|--|
| P0171   | Fuel injection system too lean (bank 1) | • Fuel injection system does not operate properly.<br>• The amount of mixture ratio compensation is too large. (The mixture ratio is too lean.) | • Intake air leaks<br>• A/F sensor 1<br>• Fuel injector<br>• Exhaust gas leaks<br>• Incorrect fuel pressure<br>• Lack of fuel<br>• Mass air flow sensor<br>• Incorrect PCV hose connection |
| P0174   | Fuel injection system too lean (bank 2) |   |  |

#### DTC CONFIRMATION PROCEDURE

##### 1. PRECONDITIONING

If DTC Confirmation Procedure has been previously conducted, always perform the following procedure before conducting the next test.

1. Turn ignition switch OFF and wait at least 10 seconds.
2. Turn ignition switch ON.
3. Turn ignition switch OFF and wait at least 10 seconds.

>> GO TO 2.

##### 2. PERFORM DTC CONFIRMATION PROCEDURE-I

1. Clear the mixture ratio self-learning value. Refer to [EC-153, "Work Procedure"](#).
2. Start engine.

Is it difficult to start engine?

- YES >> GO TO 3.  
NO >> GO TO 4.

##### 3. RESTART ENGINE

If it is difficult to start engine, the fuel injection system has a malfunction, too.  
Crank engine while depressing accelerator pedal.

#### NOTE:

When depressing accelerator pedal three fourths (3/4) or more, the control system does not start the engine.  
Do not depress accelerator pedal too much.

Does engine start?

- YES >> Go to [EC-280, "Diagnosis Procedure"](#).  
NO >> Check exhaust and intake air leak visually.

##### 4. PERFORM DTC CONFIRMATION PROCEDURE-II

1. Keep engine idle for at least 5 minutes.
2. Check 1st trip DTC.

Is 1st trip DTC detected?

# P0171, P0174 FUEL INJECTION SYSTEM FUNCTION

[VQ37VHR FOR USA AND CANADA]

## < DTC/CIRCUIT DIAGNOSIS >

- YES >> Go to [EC-280, "Diagnosis Procedure"](#).  
 NO >> GO TO 5.

### 5. PERFORM DTC CONFIRMATION PROCEDURE-III

- Turn ignition switch OFF and wait at least 10 seconds.
- Start engine.
- Maintain the following conditions for at least 10 consecutive minutes.  
Hold the accelerator pedal as steady as possible.

|               |                             |
|---------------|-----------------------------|
| VHCL SPEED SE | 50 - 120 km/h (31 - 75 MPH) |
|---------------|-----------------------------|

**CAUTION:**

**Always drive vehicle at a safe speed.**

- Check 1st trip DTC.

Is 1st trip DTC detected?

- YES >> Go to [EC-280, "Diagnosis Procedure"](#).  
 NO >> INSPECTION END

## Diagnosis Procedure

INFOID:000000006882938

### 1. CHECK EXHAUST GAS LEAK

- Start engine and run it at idle.
- Listen for an exhaust gas leak before three way catalyst 1.

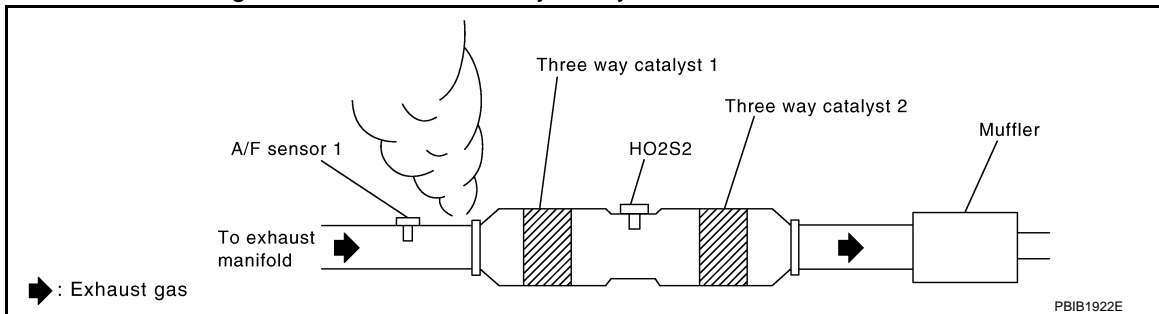

Is exhaust gas leak detected?

- YES >> Repair or replace.  
 NO >> GO TO 2.

### 2. CHECK FOR INTAKE AIR LEAK

- Listen for an intake air leak after the mass air flow sensor.
- Check PCV hose connection.

Is intake air leak detected?

- YES >> Repair or replace.  
 NO >> GO TO 3.

### 3. CHECK A/F SENSOR 1 INPUT SIGNAL CIRCUIT

- Turn ignition switch OFF.
- Disconnect corresponding A/F sensor 1 harness connector.
- Disconnect ECM harness connector.
- Check the continuity between A/F sensor 1 harness connector and ECM harness connector.

| DTC   | A/F sensor 1 |           |          | ECM       |          | Continuity |
|-------|--------------|-----------|----------|-----------|----------|------------|
|       | Bank         | Connector | Terminal | Connector | Terminal |            |
| P0171 | 1            | F3        | 1        | F102      | 57       | Existed    |
|       |              |           | 2        |           | 61       |            |
| P0174 | 2            | F20       | 1        |           | 65       |            |
|       |              |           | 2        |           | 66       |            |



# P0171, P0174 FUEL INJECTION SYSTEM FUNCTION

[VQ37VHR FOR USA AND CANADA]

## < DTC/CIRCUIT DIAGNOSIS >

5. Check the continuity between A/F sensor 1 harness connector and ground, or ECM harness connector and ground.

| DTC   | A/F sensor 1 |           |          | Ground | Continuity  |
|-------|--------------|-----------|----------|--------|-------------|
|       | Bank         | Connector | Terminal |        |             |
| P0171 | 1            | F3        | 1        | Ground | Not existed |
|       |              |           | 2        |        |             |
| P0174 | 2            | F20       | 1        |        |             |
|       |              |           | 2        |        |             |

| DTC   | ECM  |           |          | Ground | Continuity  |
|-------|------|-----------|----------|--------|-------------|
|       | Bank | Connector | Terminal |        |             |
| P0171 | 1    | F102      | 57       | Ground | Not existed |
|       |      |           | 61       |        |             |
| P0174 | 2    |           | 65       |        |             |
|       |      |           | 66       |        |             |

6. Also check harness for short to power.

Is the inspection result normal?

YES >> GO TO 4.

NO >> Repair open circuit, short to ground or short to power in harness or connectors.

## 4. CHECK FUEL PRESSURE

1. Release fuel pressure to zero. Refer to [EC-158, "Work Procedure"](#).
2. Install fuel pressure gauge and check fuel pressure. Refer to [EC-158, "Work Procedure"](#).

**At idling: Approximately 350 kPa (3.57 kg/cm<sup>2</sup>, 51 psi)**

Is the inspection result normal?

YES >> GO TO 6.

NO >> GO TO 5.

## 5. DETECT MALFUNCTIONING PART

Check fuel hoses and fuel tubes for clogging.

Is the inspection result normal?

YES >> Replace "fuel filter and fuel pump assembly". Refer to [FL-5, "Exploded View"](#).

NO >> Repair or replace.

## 6. CHECK MASS AIR FLOW SENSOR

 **With CONSULT**

1. Install all removed parts.
2. Check "MASS AIR FLOW" in "DATA MONITOR" mode with CONSULT.  
For specification, refer to [EC-545, "Mass Air Flow Sensor"](#).

 **With GST**

1. Install all removed parts.
2. Check mass air flow sensor signal in Service \$01 with GST.  
For specification, refer to [EC-545, "Mass Air Flow Sensor"](#).

Is the measurement value within the specification?

YES >> GO TO 7.

NO >> Check connectors for rusted terminals or loose connections in the mass air flow sensor circuit or grounds. Refer to [EC-211, "Diagnosis Procedure"](#).

## 7. CHECK FUNCTION OF FUEL INJECTOR

 **With CONSULT**

1. Start engine.

# P0171, P0174 FUEL INJECTION SYSTEM FUNCTION

[VQ37VHR FOR USA AND CANADA]

## < DTC/CIRCUIT DIAGNOSIS >

2. Perform "POWER BALANCE" in "ACTIVE TEST" mode with CONSULT.
3. Make sure that each circuit produces a momentary engine speed drop.

### ⊗ Without CONSULT

1. Start engine and let it idle.
2. Listen to each fuel injector operating sound.

**Clicking sound should be heard.**

### Is the inspection result normal?

YES >> GO TO 8.

NO >> Perform trouble diagnosis for FUEL INJECTOR, refer to [EC-512. "Diagnosis Procedure"](#).

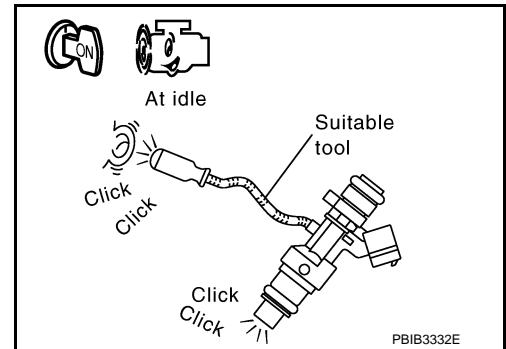

## 8. CHECK FUEL INJECTOR

1. Turn ignition switch OFF.
2. Confirm that the engine is cooled down and there are no fire hazards near the vehicle.
3. Disconnect all fuel injector harness connectors.
4. Remove fuel tube assembly. Refer to [EM-39. "Removal and Installation"](#).  
Keep fuel hose and all fuel injectors connected to fuel tube.
5. For DTC P0171, reconnect fuel injector harness connectors on bank 1.  
For DTC P0174, reconnect fuel injector harness connectors on bank 2.
6. Disconnect all ignition coil harness connectors.
7. Prepare pans or saucers under each fuel injector.
8. Crank engine for about 3 seconds.  
For DTC P0171, make sure that fuel sprays out from fuel injectors on bank 1.  
For DTC P0174, make sure that fuel sprays out from fuel injectors on bank 2.

**Fuel should be sprayed evenly for each fuel injector.**

### Is the inspection result normal?

YES >> GO TO 9.

NO >> Replace fuel injectors from which fuel does not spray out. Always replace O-ring with new ones.

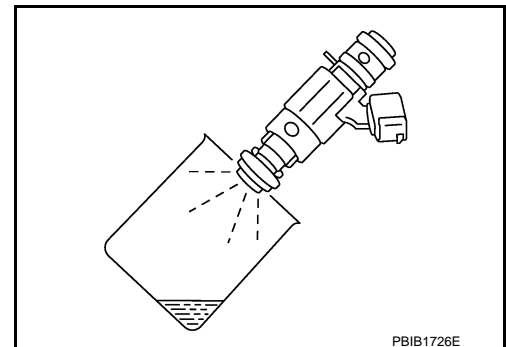

## 9. CHECK INTERMITTENT INCIDENT

Refer to [GI-44. "Intermittent Incident"](#).

>> INSPECTION END

# P0172, P0175 FUEL INJECTION SYSTEM FUNCTION

< DTC/CIRCUIT DIAGNOSIS >

[VQ37VHR FOR USA AND CANADA]

## P0172, P0175 FUEL INJECTION SYSTEM FUNCTION

### DTC Logic

INFOID:000000006882939

#### DTC DETECTION LOGIC

With the Air/Fuel Mixture Ratio Self-Learning Control, the actual mixture ratio can be brought closely to the theoretical mixture ratio based on the mixture ratio feedback signal from A/F sensor 1. The ECM calculates the necessary compensation to correct the offset between the actual and the theoretical ratios.

In case the amount of the compensation value is extremely large (the actual mixture ratio is too rich), the ECM judges the condition as the fuel injection system malfunction and illuminates the MIL (2 trip detection logic).

| Sensor       | Input signal to ECM   | ECM function           | Actuator      |
|--------------|---|------------------------|---------------|
| A/F sensor 1 | Density of oxygen in exhaust gas<br>(Mixture ratio feedback signal) | Fuel injection control | Fuel injector |

| DTC No. | Trouble diagnosis name                  | DTC detecting condition  | Possible cause  |
|---------|---|--|---|
| P0172   | Fuel injection system too rich (bank 1) | • Fuel injection system does not operate properly.<br>• The amount of mixture ratio compensation is too large.<br>(The mixture ratio is too rich.) | • A/F sensor 1<br>• Fuel injector<br>• Exhaust gas leaks<br>• Incorrect fuel pressure<br>• Mass air flow sensor |
| P0175   | Fuel injection system too rich (bank 2) |  |   |

#### DTC CONFIRMATION PROCEDURE

##### 1. PRECONDITIONING

If DTC Confirmation Procedure has been previously conducted, always perform the following procedure before conducting the next test.

1. Turn ignition switch OFF and wait at least 10 seconds.
2. Turn ignition switch ON.
3. Turn ignition switch OFF and wait at least 10 seconds.

>> GO TO 2.

##### 2. PERFORM DTC CONFIRMATION PROCEDURE-I

1. Clear the mixture ratio self-learning value. Refer to [EC-153, "Work Procedure"](#).
2. Start engine.

Is it difficult to start engine?

YES >> GO TO 3.

NO >> GO TO 4.

##### 3. RESTART ENGINE

If it is difficult to start engine, the fuel injection system has a malfunction, too.

Crank engine while depressing accelerator pedal.

#### NOTE:

When depressing accelerator pedal three fourths (3/4) or more, the control system does not start the engine. Do not depress accelerator pedal too much.

Does engine start?

YES >> Go to [EC-284, "Diagnosis Procedure"](#).

NO >> Remove spark plugs and check for fouling, etc.

##### 4. PERFORM DTC CONFIRMATION PROCEDURE-II

1. Keep engine idle for at least 10 minutes.
2. Check 1st trip DTC.

Is 1st trip DTC detected?

YES >> Go to [EC-284, "Diagnosis Procedure"](#).

NO >> GO TO 5.

##### 5. PERFORM DTC CONFIRMATION PROCEDURE-III

# P0172, P0175 FUEL INJECTION SYSTEM FUNCTION

[VQ37VHR FOR USA AND CANADA]

## < DTC/CIRCUIT DIAGNOSIS >

1. Turn ignition switch OFF and wait at least 10 seconds.
2. Start engine.
3. Maintain the following conditions for at least 10 consecutive minutes.  
Hold the accelerator pedal as steady as possible.

|               |                             |
|---------------|-----------------------------|
| VHCL SPEED SE | 50 - 120 km/h (31 - 75 MPH) |
|---------------|-----------------------------|

### CAUTION:

**Always drive vehicle at a safe speed.**

4. Check 1st trip DTC.

### Is 1st trip DTC detected?

- YES >> Go to [EC-284, "Diagnosis Procedure"](#).  
NO >> INSPECTION END

## Diagnosis Procedure

INFOID:000000006882940

### 1. CHECK EXHAUST GAS LEAK

1. Start engine and run it at idle.
2. Listen for an exhaust gas leak before three way catalyst 1.

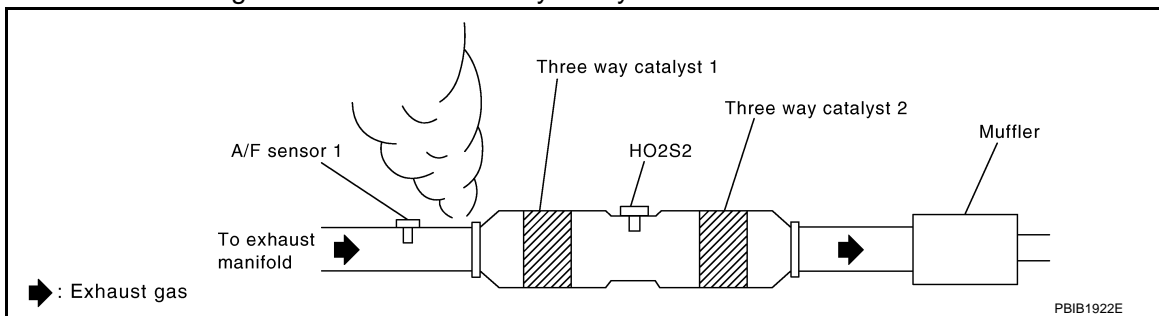

### Is exhaust gas leak detected?

- YES >> Repair or replace.  
NO >> GO TO 2.

### 2. CHECK FOR INTAKE AIR LEAK

Listen for an intake air leak after the mass air flow sensor.

### Is intake air leak detected?

- YES >> Repair or replace.  
NO >> GO TO 3.

### 3. CHECK A/F SENSOR 1 INPUT SIGNAL CIRCUIT

1. Turn ignition switch OFF.
2. Disconnect corresponding A/F sensor 1 harness connector.
3. Disconnect ECM harness connector.
4. Check the continuity between A/F sensor 1 harness connector and ECM harness connector.

| DTC   | A/F sensor 1 |           |          | ECM       |          | Continuity |
|-------|--------------|-----------|----------|-----------|----------|------------|
|       | Bank         | Connector | Terminal | Connector | Terminal |            |
| P0172 | 1            | F3        | 1        | F102      | 57       | Existed    |
|       |              |           | 2        |           | 61       |            |
| P0175 | 2            | F20       | 1        |           | 65       |            |
|       |              |           | 2        |           | 66       |            |

5. Check the continuity between A/F sensor 1 harness connector and ground, or ECM harness connector and ground.

# P0172, P0175 FUEL INJECTION SYSTEM FUNCTION

< DTC/CIRCUIT DIAGNOSIS >

[VQ37VHR FOR USA AND CANADA]

| DTC   | A/F sensor 1 |           |          | Ground | Continuity  |
|-------|--------------|-----------|----------|--------|-------------|
|       | Bank         | Connector | Terminal |        |             |
| P0172 | 1            | F3        | 1        | Ground | Not existed |
|       |              |           | 2        |        |             |
| P0175 | 2            | F20       | 1        |        |             |
|       |              |           | 2        |        |             |

| DTC   | ECM  |           |          | Ground | Continuity  |
|-------|------|-----------|----------|--------|-------------|
|       | Bank | Connector | Terminal |        |             |
| P0172 | 1    | F102      | 57       | Ground | Not existed |
|       |      |           | 61       |        |             |
| P0175 | 2    |           | 65       |        |             |
|       |      |           | 66       |        |             |

6. Also check harness for short to power.

Is the inspection result normal?

YES >> GO TO 4.

NO >> Repair open circuit, short to ground or short to power in harness or connectors.

## 4.CHECK FUEL PRESSURE

1. Release fuel pressure to zero. Refer to [EC-158, "Work Procedure"](#).

2. Install fuel pressure gauge and check fuel pressure. Refer to [EC-158, "Work Procedure"](#).

**At idling: Approximately 350 kPa (3.57 kg/cm<sup>2</sup>, 51 psi)**

Is the inspection result normal?

YES >> GO TO 5.

NO >> Replace "fuel filter and fuel pump assembly". Refer to [FL-5, "Exploded View"](#).

## 5.CHECK MASS AIR FLOW SENSOR

### With CONSULT

1. Install all removed parts.

2. Check "MASS AIR FLOW" in "DATA MONITOR" mode with CONSULT.  
For specification, refer to [EC-545, "Mass Air Flow Sensor"](#).

### With GST

1. Install all removed parts.

2. Check mass air flow sensor signal in "Service \$01" with GST.  
For specification, refer to [EC-545, "Mass Air Flow Sensor"](#).

Is the measurement value within the specification?

YES >> GO TO 6.

NO >> Check connectors for rusted terminals or loose connections in the mass air flow sensor circuit or grounds. Refer to [EC-211, "Diagnosis Procedure"](#).

## 6.CHECK FUNCTION OF FUEL INJECTOR

### With CONSULT

1. Start engine.

2. Perform "POWER BALANCE" in "ACTIVE TEST" mode with CONSULT.

3. Make sure that each circuit produces a momentary engine speed drop.

### Without CONSULT

1. Start engine and let it idle.

## P0172, P0175 FUEL INJECTION SYSTEM FUNCTION

< DTC/CIRCUIT DIAGNOSIS >

[VQ37VHR FOR USA AND CANADA]

- Listen to each fuel injector operating sound.

**Clicking sound should be heard.**

Is the inspection result normal?

YES >> GO TO 7.

NO >> Perform trouble diagnosis for FUEL INJECTOR, refer to [EC-512. "Diagnosis Procedure"](#).

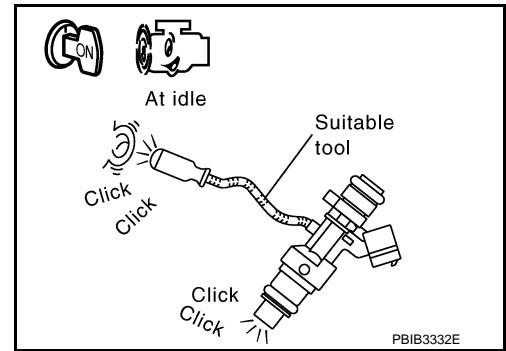

### 7. CHECK FUEL INJECTOR

- Remove fuel injector assembly. Refer to [EM-39. "Removal and Installation"](#).  
Keep fuel hose and all fuel injectors connected to fuel tube.
- Confirm that the engine is cooled down and there are no fire hazards near the vehicle.
- Disconnect all fuel injector harness connectors.
- Disconnect all ignition coil harness connectors.
- Prepare pans or saucers under each fuel injector.
- Crank engine for about 3 seconds.  
Make sure fuel that does not drip from fuel injector.

Is the inspection result normal?

YES >> GO TO 8.

NO >> Replace the fuel injectors from which fuel is dripping. Always replace O-ring with new one.

### 8. CHECK INTERMITTENT INCIDENT

Refer to [GI-44. "Intermittent Incident"](#).

>> INSPECTION END

# P0181 FTT SENSOR

< DTC/CIRCUIT DIAGNOSIS >

[VQ37VHR FOR USA AND CANADA]

## P0181 FTT SENSOR

### DTC Logic

INFOID:000000006882941

### DTC DETECTION LOGIC

| DTC No. | Trouble diagnosis<br>(Trouble diagnosis content)                                    | DTC detecting condition |  | Possible cause   |
|---------|---|-------------------------|--|--|
| P0181   | FTT SENSOR<br>[Fuel tank temperature<br>(FTT) sensor circuit range/<br>performance] | A)                      | Rationally incorrect voltage from the sensor is sent to ECM, compared with the voltage signals from ECT sensor and intake air temperature sensor.  | <ul style="list-style-type: none"><li>• Harness or connectors (The FTT sensor circuit is open or shorted)</li><li>• FTT sensor</li></ul> |
|         |   | B)                      | The comparison result of signals transmitted to ECM from each temperature sensor (IAT sensor, ECT sensor, EOT sensor, and FTT sensor) shows that the voltage signal of the FTT sensor is higher/lower than that of other temperature sensors when the engine is started with its cold state. |  |

### DTC CONFIRMATION PROCEDURE

#### 1.INSPECTION START

##### Is it necessary to erase permanent DTC?

- YES >> GO TO 7.  
NO >> GO TO 2.

#### 2.PRECONDITIONING

If DTC Confirmation Procedure has been previously conducted, always perform the following procedure before conducting the next test.

1. Turn ignition switch OFF and wait at least 10 seconds.
2. Turn ignition switch ON.
3. Turn ignition switch OFF and wait at least 10 seconds.

>> GO TO 3.

#### 3.PERFORM DTC CONFIRMATION PROCEDURE-I

1. Turn ignition switch ON and wait at least 10 seconds.
2. Check 1st trip DTC.

##### Is 1st trip DTC detected?

- YES >> Go to [EC-289, "Diagnosis Procedure"](#).  
NO >> GO TO 4.

#### 4.CHECK ENGINE COOLANT TEMPERATURE

1. Select "COOLAN TEMP/S" in "DATA MONITOR" with CONSULT.
2. Check "COOLAN TEMP/S" value.

##### "COOLAN TEMP/S" less than 60°C (140°F)?

- YES >> INSPECTION END  
NO >> GO TO 5.

#### 5.PERFORM DTC CONFIRMATION PROCEDURE-II

1. Cool engine down until "COOLAN TEMP/S" is less than 60°C (140°F).
2. Wait at least 10 seconds.
3. Check 1st trip DTC.

##### Is 1st trip DTC detected?

- YES >> Go to [EC-289, "Diagnosis Procedure"](#).  
NO >> GO TO 6.

# P0181 FTT SENSOR

[VQ37VHR FOR USA AND CANADA]

< DTC/CIRCUIT DIAGNOSIS >

## 6. PERFORM COMPONENT FUNCTION CHECK (FOR MALFUNCTION B)

Perform component function check. Refer to [EC-288, "Component Function Check"](#).

### NOTE:

Use the component function check to check the overall function of the FTT sensor circuit. During this check, a 1st trip DTC might not be confirmed.

Is the inspection result normal?

YES >> INSPECTION END

NO >> Proceed to [EC-289, "Diagnosis Procedure"](#).

## 7. PRECONDITIONING

If DTC CONFIRMATION PROCEDURE has been previously conducted, always perform the following procedure before conducting the next test.

1. Turn ignition switch OFF and wait at least 10 seconds.
2. Turn ignition switch ON.
3. Turn ignition switch OFF and wait at least 10 seconds.

### TEST CONDITION:

- Before performing the following procedure, do not add fuel.
- Before performing the following procedure, check that fuel level is between 1/4 and 4/4.
- Before performing the following procedure, confirm that battery voltage is 11 V or more at idle.

>> GO TO 8.

## 8. PERFORM DTC CONFIRMATION PROCEDURE B

1. Start engine and let it idle for 60 minutes.
2. Move the vehicle to a cool place.

### NOTE:

Cool the vehicle in an environment of ambient air temperature between  $-10^{\circ}\text{C}$  ( $14^{\circ}\text{F}$ ) and  $35^{\circ}\text{C}$  ( $95^{\circ}\text{F}$ ).

3. Turn ignition switch OFF and soak the vehicle for 12 hours.

### CAUTION:

**Never turn ignition switch ON during soaking.**

### NOTE:

The vehicle must be cooled with the hood open.

4. Start engine and let it idle for 5 minutes or more.

### CAUTION:

**Never turn ignition switch OFF during idling.**

5. Check 1st trip DTC.

Is 1st trip DTC detected?

YES >> Proceed to [EC-289, "Diagnosis Procedure"](#).

NO >> INSPECTION END

## Component Function Check

INFOID:000000007212350

### 1. CHECK FUEL TANK TEMPERATURE SENSOR

1. Turn ignition switch OFF.
2. Disconnect "fuel level sensor unit and fuel pump" harness connector.
3. Remove fuel level sensor unit. Refer to [FL-5, "Exploded View"](#).
4. Check resistance between "fuel level sensor unit and fuel pump" terminals by heating with hot water as shown in the figure.

| Terminals | Condition  | Resistance (k $\Omega$ ) |
|-----------|--|--------------------------|
| 4 and 5   | Temperature [ $^{\circ}\text{C}$ ( $^{\circ}\text{F}$ )] | 20 (68) 2.3 - 2.7        |
|           |  | 50 (122) 0.79 - 0.90     |

Is the inspection result normal?

YES >> GO TO 2.

NO >> Proceed to [EC-289, "Diagnosis Procedure"](#).

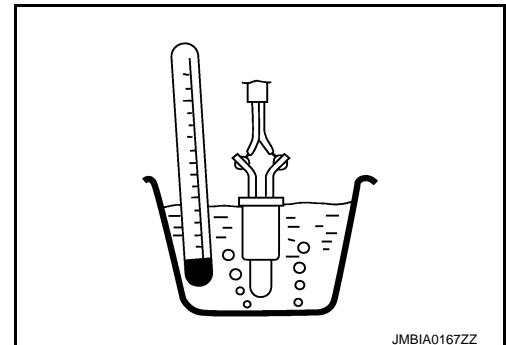



# P0181 FTT SENSOR

< DTC/CIRCUIT DIAGNOSIS >

[VQ37VHR FOR USA AND CANADA]

## 2.CHECK INTERMITTENT INCIDENT

Check intermittent incident. Refer to [GI-44, "Intermittent Incident"](#).

Is the inspection result normal?

YES >> INSPECTION END

NO >> Proceed to [EC-289, "Diagnosis Procedure"](#).

## Diagnosis Procedure

INFOID:000000007212351

### 1.INSPECTION START

Confirm the detected malfunction (A or B). Refer to [EC-287, "DTC Logic"](#).

Which malfunction is detected?

YES >> GO TO 2.

NO >> GO TO 7.

### 2.CHECK DTC WITH COMBINATION METER

Refer to [MWI-31, "CONSULT Function"](#).

Is the inspection result normal?

YES >> GO TO 3.

NO >> Go to [MWI-62, "Component Function Check"](#).

### 3.CHECK FUEL TANK TEMPERATURE SENSOR POWER SUPPLY CIRCUIT

1. Turn ignition switch OFF.
2. Disconnect "fuel level sensor unit and fuel pump" harness connector.
3. Turn ignition switch ON.
4. Check the voltage between "fuel level sensor unit and fuel pump" harness connector and ground.

| Fuel level sensor unit and fuel pump |          | Ground | Voltage (V) |
|--------------------------------------|----------|--------|-------------|
| Connector                            | Terminal |        |             |
| B241                                 | 4        | Ground | Approx. 5   |

Is the inspection result normal?

YES >> GO TO 5.

NO >> GO TO 4.

### 4.DETECT MALFUNCTIONING PART

Check the following.

- Harness connectors B201, M117
- Harness for open or short between ECM and "fuel level sensor unit and fuel pump"

>> Repair open circuit, short to ground or short to power in harness or connector.

### 5.CHECK FUEL TANK TEMPERATURE SENSOR GROUND CIRCUIT FOR OPEN AND SHORT

1. Turn ignition switch OFF.
2. Disconnect combination meter harness connector.
3. Check the continuity between "fuel level sensor unit and fuel pump" harness connector and combination meter harness connector.

| Fuel level sensor unit and fuel pump |          | Combination meter |          | Continuity |
|--------------------------------------|----------|-------------------|----------|------------|
| Connector                            | Terminal | Connector         | Terminal |            |
| B241                                 | 5        | M53               | 24       | Existed    |

4. Also check harness for short to ground and short to power.

Is the inspection result normal?

YES >> GO TO 7.

NO >> GO TO 6.

# P0181 FTT SENSOR

[VQ37VHR FOR USA AND CANADA]

< DTC/CIRCUIT DIAGNOSIS >

## 6. DETECT MALFUNCTIONING PART

Check the following.

- Harness connectors B201, M117
- Harness for open or short between “fuel level sensor unit and fuel pump” and combination meter

>> Repair open circuit, short to ground or short to power in harness or connector.

## 7. CHECK FUEL TANK TEMPERATURE SENSOR

Refer to [EC-290, "Component Inspection"](#).

Is the inspection result normal?

YES >> GO TO 8.

NO >> Replace “fuel level sensor unit and fuel pump”. Refer to [FL-5, "Exploded View"](#).

## 8. CHECK INTERMITTENT INCIDENT

Refer to [GI-44, "Intermittent Incident"](#).

>> INSPECTION END

## Component Inspection

INFOID:000000007212352

## 1. CHECK FUEL TANK TEMPERATURE SENSOR

1. Turn ignition switch OFF.
2. Disconnect “fuel level sensor unit and fuel pump” harness connector.
3. Remove fuel level sensor unit. Refer to [FL-5, "Exploded View"](#).
4. Check resistance between “fuel level sensor unit and fuel pump” terminals by heating with hot water as shown in the figure.

| Terminals | Condition             | Resistance (kΩ) |             |
|-----------|-----------------------|-----------------|-------------|
| 4 and 5   | Temperature [°C (°F)] | 20 (68)         | 2.3 - 2.7   |
|           |                       | 50 (122)        | 0.79 - 0.90 |

Is the inspection result normal?

YES >> INSPECTION END

NO >> Replace “fuel level sensor unit and fuel pump”. Refer to [FL-5, "Exploded View"](#).

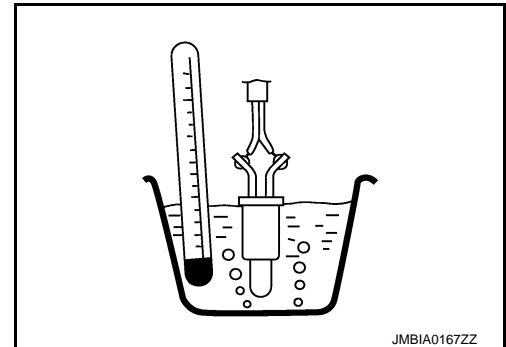

# P0182, P0183 FTT SENSOR

< DTC/CIRCUIT DIAGNOSIS >

[VQ37VHR FOR USA AND CANADA]

## P0182, P0183 FTT SENSOR

### DTC Logic

INFOID:000000006882944

### DTC DETECTION LOGIC

| DTC No. | Trouble diagnosis name                          | DTC detecting condition                                     | Possible cause   |
|---------|---|---|--|
| P0182   | Fuel tank temperature sensor circuit low input  | An excessively low voltage from the sensor is sent to ECM.  | <ul style="list-style-type: none"> <li>• Harness or connectors (The sensor circuit is open or shorted.)</li> <li>• Fuel tank temperature sensor</li> </ul> |
| P0183   | Fuel tank temperature sensor circuit high input | An excessively high voltage from the sensor is sent to ECM. |  |

### DTC CONFIRMATION PROCEDURE

#### 1. PRECONDITIONING

If DTC Confirmation Procedure has been previously conducted, always perform the following procedure before conducting the next test.

1. Turn ignition switch OFF and wait at least 10 seconds.
2. Turn ignition switch ON.
3. Turn ignition switch OFF and wait at least 10 seconds.

>> GO TO 2.

#### 2. PERFORM DTC CONFIRMATION PROCEDURE

1. Turn ignition switch ON and wait at least 5 seconds.
2. Check 1st trip DTC.

Is 1st trip DTC detected?

- YES >> Go to [EC-291, "Diagnosis Procedure"](#).  
 NO >> INSPECTION END

### Diagnosis Procedure

INFOID:000000006882945

#### 1. CHECK GROUND CONNECTION

1. Turn ignition switch OFF.
2. Check ground connection M95. Refer to Ground Inspection in [GI-47, "Circuit Inspection"](#).

Is the inspection result normal?

- YES >> GO TO 2.  
 NO >> Repair or replace ground connection.

#### 2. CHECK DTC WITH "COMBINATION METER"

Refer to [MWI-31, "CONSULT Function"](#).

Is the inspection result normal?

- YES >> GO TO 3.  
 NO >> Go to [MWI-62, "Component Function Check"](#).

#### 3. CHECK FUEL TANK TEMPERATURE SENSOR POWER SUPPLY CIRCUIT

1. Turn ignition switch OFF.
2. Disconnect "fuel level sensor unit and fuel pump" harness connector.
3. Turn ignition switch ON.
4. Check the voltage between "fuel level sensor unit and fuel pump" harness connector and ground.

| Fuel level sensor unit and fuel pump |          | Ground | Voltage (V) |
|--------------------------------------|----------|--------|-------------|
| Connector                            | Terminal |        |             |
| B241                                 | 4        | Ground | Approx. 5   |

Is the inspection result normal?

## P0182, P0183 FTT SENSOR

< DTC/CIRCUIT DIAGNOSIS >

[VQ37VHR FOR USA AND CANADA]

- YES >> GO TO 5.  
NO >> GO TO 4.

### 4. DETECT MALFUNCTIONING PART

Check the following.

- Harness connectors M117, B201
- Harness for open or short between ECM and “fuel level sensor unit and fuel pump”

>> Repair open circuit, short to ground or short to power in harness or connector.

### 5. CHECK FUEL TANK TEMPERATURE SENSOR GROUND CIRCUIT FOR OPEN AND SHORT

1. Turn ignition switch OFF.
2. Disconnect “combination meter” harness connector.
3. Check the continuity between “fuel level sensor unit and fuel pump” harness connector and “combination meter” harness connector.

| Fuel level sensor unit and fuel pump |          | Combination meter |          | Continuity |
|--------------------------------------|----------|-------------------|----------|------------|
| Connector                            | Terminal | Connector         | Terminal |            |
| B241                                 | 5        | M53               | 24       | Existed    |

4. Also check harness for short to ground and short to power.

Is the inspection result normal?

- YES >> GO TO 7.  
NO >> GO TO 6.

### 6. DETECT MALFUNCTIONING PART

Check the following.

- Harness connectors M117, B201
- Harness for open or short between “fuel level sensor unit and fuel pump” and “combination meter”

>> Repair open circuit, short to ground or short to power in harness or connector.

### 7. CHECK FUEL TANK TEMPERATURE SENSOR

Refer to [EC-292, "Component Inspection"](#).

Is the inspection result normal?

- YES >> GO TO 8.  
NO >> Replace “fuel level sensor unit and fuel pump”. Refer to [FL-5, "Exploded View"](#).

### 8. CHECK INTERMITTENT INCIDENT

Refer to [GI-44, "Intermittent Incident"](#).

>> INSPECTION END

## Component Inspection

INFOID:000000006882946

### 1. CHECK FUEL TANK TEMPERATURE SENSOR

1. Turn ignition switch OFF.
2. Disconnect “fuel level sensor unit and fuel pump” harness connector.
3. Remove fuel level sensor unit. Refer to [FL-5, "Exploded View"](#).

# P0182, P0183 FTT SENSOR

[VQ37VHR FOR USA AND CANADA]

< DTC/CIRCUIT DIAGNOSIS >

4. Check resistance between “fuel level sensor unit and fuel pump” terminals by heating with hot water as shown in the figure.

| Terminals | Condition             | Resistance (kΩ) |             |
|-----------|-----------------------|-----------------|-------------|
| 4 and 5   | Temperature [°C (°F)] | 20 (68)         | 2.3 - 2.7   |
|           |                       | 50 (122)        | 0.79 - 0.90 |

Is the inspection result normal?

YES >> INSPECTION END

NO >> Replace “fuel level sensor unit and fuel pump”. Refer to [FL-5. "Exploded View"](#).

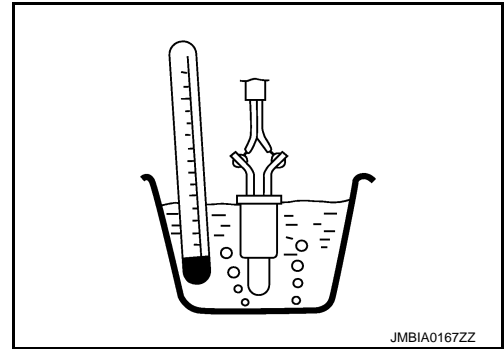

A

EC

C

D

E

F

G

H

I

J

K

L

M

N

O

P

# P0196 EOT SENSOR

< DTC/CIRCUIT DIAGNOSIS >

[VQ37VHR FOR USA AND CANADA]

## P0196 EOT SENSOR

### DTC Logic

INFOID:000000006882947

#### DTC DETECTION LOGIC

##### NOTE:

If DTC P0196 is displayed with P0197 or P0198, first perform the trouble diagnosis for DTC P0197 or P0198. Refer to [EC-298, "DTC Logic"](#).

| DTC No. | Trouble diagnosis<br>(Trouble diagnosis content)                         | DTC detecting condition |  | Possible cause   |
|---------|--|-------------------------|--|--|
| P0196   | EOT SENSOR<br>[Engine oil temperature (EOT)<br>sensor range/performance] | A)                      | Rationally incorrect voltage from the sensor is sent to ECM, compared with the voltage signals from engine coolant temperature sensor and intake air temperature sensor.   | <ul style="list-style-type: none"><li>• Harness or connectors (The EOT sensor circuit is open or shorted)</li><li>• EOT sensor</li></ul> |
|         |  | B)                      | The comparison result of signals transmitted to ECM from each temperature sensor (IAT sensor, ECT sensor, EOT sensor, and FTT sensor) shows that the voltage signal of the EOT sensor is higher/lower than that of other temperature sensors when the engine is started with its cold state. |  |

#### DTC CONFIRMATION PROCEDURE

##### 1.INSPECTION START

##### Is it necessary to erase permanent DTC?

- YES >> GO TO 6.
- NO >> GO TO 2.

##### 2.PRECONDITIONING

If DTC Confirmation Procedure has been previously conducted, always perform the following procedure before conducting the next test.

1. Turn ignition switch OFF and wait at least 10 seconds.
2. Turn ignition switch ON.
3. Turn ignition switch OFF and wait at least 10 seconds.

##### TESTING CONDITION:

Before performing the following procedure, confirm that battery voltage is more than 11 V at idle.

>> GO TO 3.

##### 3.PERFORM DTC CONFIRMATION PROCEDURE-I

1. Start engine and warm it up to normal operating temperature.
2. Turn ignition switch OFF and wait at least 10 seconds.
3. Turn ignition switch ON.
4. Turn ignition switch OFF and wait at least 10 seconds.
5. Start engine and let it idle for 5 minutes and 10 seconds.
6. Check 1st trip DTC.

##### Is 1st trip DTC detected?

- YES >> [EC-296, "Diagnosis Procedure"](#).
- NO >> GO TO 4.

##### 4.PERFORM DTC CONFIRMATION PROCEDURE-II

1. Select "DATA MONITOR" mode with CONSULT.
2. Check that "COOLAN TEMP/S" indicates above 80°C (176°F).  
If it is above 80°C (176°F), go to the following steps.  
If it is below 80°C (176°F), warm engine up until "COOLAN TEMP/S" indicates more than 80°C (176°F).  
Then perform the following steps.
3. Turn ignition switch OFF and soak the vehicle in a cool place.

# P0196 EOT SENSOR

[VQ37VHR FOR USA AND CANADA]

## < DTC/CIRCUIT DIAGNOSIS >

4. Turn ignition switch ON.
5. Turn ignition switch OFF and wait at least 10 seconds.
6. Turn ignition switch ON.

**NOTE:**

**Do not turn ignition switch OFF until step 10.**

7. Select "DATA MONITOR" mode with CONSULT.
8. Check the following.

|  |                    |
|--|--------------------|
| COOLAN TEMP/S  | Below 40°C (104°F) |
| INT/A TEMP SE  | Below 40°C (104°F) |
| Difference between "COOLAN TEMP/S" and "INT/A TEMP SE" | Within 6°C (11°F)  |

If they are within the specified range, perform the following steps.

If they are out of the specified range, soak the vehicle to meet the above conditions. Then perform the following steps.

**NOTE:**

- **Do not turn ignition switch OFF.**
- **If it is supposed to need a long period of time, do not deplete the battery.**

9. Start engine and let it idle for 5 minutes.
10. Check 1st trip DTC.

Is 1st trip DTC detected?

YES >> [EC-296, "Diagnosis Procedure"](#).

NO >> GO TO 5.

## 5.PERFORM COMPONENT FUNCTION CHECK (FOR MALFUNCTION B)

Perform component function check. Refer to [EC-296, "Component Function Check"](#).

**NOTE:**

Use the component function check to check the overall function of the EOT sensor circuit. During this check, a 1st trip DTC might not be confirmed.

Is the inspection result normal?

YES >> INSPECTION END

NO >> Proceed to [EC-296, "Diagnosis Procedure"](#).

## 6.PRECONDITIONING

If DTC CONFIRMATION PROCEDURE has been previously conducted, always perform the following procedure before conducting the next test.

1. Turn ignition switch OFF and wait at least 10 seconds.
2. Turn ignition switch ON.
3. Turn ignition switch OFF and wait at least 10 seconds.

**TEST CONDITION:**

- **Before performing the following procedure, do not add fuel.**
- **Before performing the following procedure, check that fuel level is between 1/4 and 4/4.**
- **Before performing the following procedure, confirm that battery voltage is 11 V or more at idle.**

>> GO TO 7.

## 7.PERFORM DTC CONFIRMATION PROCEDURE B

1. Start engine and let it idle for 60 minutes.
2. Move the vehicle to a cool place.

**NOTE:**

Cool the vehicle in an environment of ambient air temperature between -10°C (14°F) and 35°C (95°F).

3. Turn ignition switch OFF and soak the vehicle for 12 hours.

**CAUTION:**

**Never turn ignition switch ON during soaking.**

**NOTE:**

The vehicle must be cooled with the hood open.

4. Start engine and let it idle for 5 minutes or more.

**CAUTION:**

**Never turn ignition switch OFF during idling.**

# P0196 EOT SENSOR

[VQ37VHR FOR USA AND CANADA]

## < DTC/CIRCUIT DIAGNOSIS >

5. Check 1st trip DTC.

Is 1st trip DTC detected?

- YES >> Proceed to [EC-296, "Diagnosis Procedure"](#).
- NO >> INSPECTION END

## Component Function Check

INFOID:000000007215006

### 1. CHECK ENGINE OIL TEMPERATURE (EOT) SENSOR

1. Turn ignition switch OFF.
2. Disconnect EOT sensor harness connector.
3. Remove EOT sensor. Refer to [EM-45, "Exploded View"](#).
4. Check resistance between EOT sensor terminals by heating with hot water as shown in the figure.

| Terminals | Condition             |          | Resistance (kΩ) |
|-----------|-----------------------|----------|-----------------|
| 1 and 2   | Temperature [°C (°F)] | 20 (68)  | 2.10 - 2.90     |
|           |                       | 50 (122) | 0.68 - 1.00     |
|           |                       | 90 (194) | 0.236 - 0.260   |

Is the inspection result normal?

- YES >> GO TO 2.
- NO >> Proceed to [EC-296, "Diagnosis Procedure"](#).

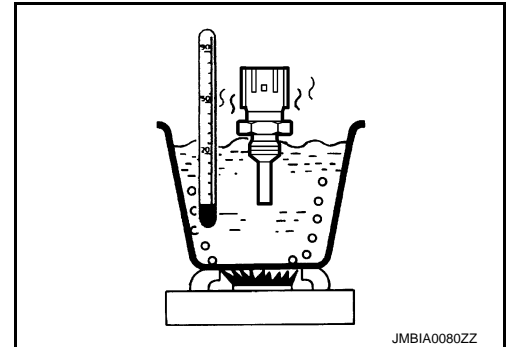

### 2. CHECK INTERMITTENT INCIDENT

Check intermittent incident. Refer to [GI-44, "Intermittent Incident"](#).

Is the inspection result normal?

- YES >> INSPECTION END
- NO >> Proceed to [EC-296, "Diagnosis Procedure"](#).

## Diagnosis Procedure

INFOID:000000007215007

### 1. CHECK GROUND CONNECTION

1. Turn ignition switch OFF.
2. Check ground connection M95. Refer to Ground Inspection in [GI-47, "Circuit Inspection"](#).

Is the inspection result normal?

- YES >> GO TO 2.
- NO >> Repair or replace ground connection.

### 2. CHECK ENGINE OIL TEMPERATURE SENSOR

Refer to [EC-296, "Component Inspection"](#).

Is the inspection result normal?

- YES >> GO TO 3.
- NO >> Replace engine oil temperature sensor. Refer to [EM-45, "Exploded View"](#).

### 3. CHECK INTERMITTENT INCIDENT

Refer to [GI-44, "Intermittent Incident"](#).

>> INSPECTION END

## Component Inspection

INFOID:000000007215008

### 1. CHECK ENGINE OIL TEMPERATURE SENSOR

1. Turn ignition switch OFF.
2. Disconnect engine oil temperature sensor harness connector.
3. Remove engine oil temperature sensor. Refer to [EM-45, "Exploded View"](#).



# P0196 EOT SENSOR

[VQ37VHR FOR USA AND CANADA]

## < DTC/CIRCUIT DIAGNOSIS >

4. Check resistance between engine oil temperature sensor terminals by heating with hot water as shown in the figure.

| Terminals | Condition             |          | Resistance (kΩ) |
|-----------|-----------------------|----------|-----------------|
| 1 and 2   | Temperature [°C (°F)] | 20 (68)  | 2.10 - 2.90     |
|           |                       | 50 (122) | 0.68 - 1.00     |
|           |                       | 90 (194) | 0.236 - 0.260   |

Is the inspection result normal?

YES >> INSPECTION END

NO >> Replace engine oil temperature sensor. Refer to [EM-45](#), "[Exploded View](#)".

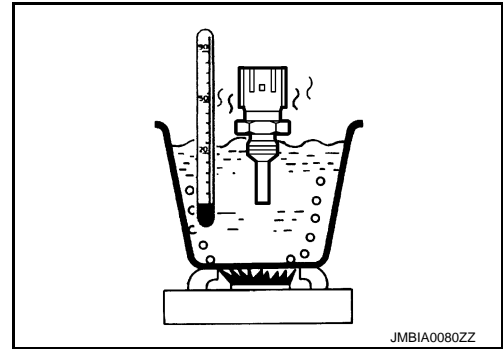

A

EC

C

D

E

F

G

H

I

J

K

L

M

N

O

P

# P0197, P0198 EOT SENSOR

< DTC/CIRCUIT DIAGNOSIS >

[VQ37VHR FOR USA AND CANADA]

## P0197, P0198 EOT SENSOR

### DTC Logic

INFOID:000000006882950

### DTC DETECTION LOGIC

| DTC No. | Trouble Diagnosis Name                           | DTC Detecting Condition                                     | Possible Cause   |
|---------|--|---|--|
| P0197   | Engine oil temperature sensor circuit low input  | An excessively low voltage from the sensor is sent to ECM.  | <ul style="list-style-type: none"><li>• Harness or connectors (The sensor circuit is open or shorted.)</li><li>• Engine oil temperature sensor</li></ul> |
| P0198   | Engine oil temperature sensor circuit high input | An excessively high voltage from the sensor is sent to ECM. |  |

### DTC CONFIRMATION PROCEDURE

#### 1. PRECONDITIONING

If DTC Confirmation Procedure has been previously conducted, always perform the following procedure before conducting the next test.

1. Turn ignition switch OFF and wait at least 10 seconds.
2. Turn ignition switch ON.
3. Turn ignition switch OFF and wait at least 10 seconds.

>> GO TO 2.

#### 2. PERFORM DTC CONFIRMATION PROCEDURE

1. Start engine and wait at least 5 seconds.
2. Check 1st trip DTC.

Is 1st trip DTC detected?

- YES >> Go to [EC-298, "Diagnosis Procedure"](#).  
NO >> INSPECTION END

### Diagnosis Procedure

INFOID:000000006882951

#### 1. CHECK GROUND CONNECTION

1. Turn ignition switch OFF.
2. Check ground connection M95. Refer to Ground Inspection in [GI-47, "Circuit Inspection"](#).

Is the inspection result normal?

- YES >> GO TO 2.  
NO >> Repair or replace ground connection.

#### 2. CHECK EOT SENSOR POWER SUPPLY CIRCUIT

1. Disconnect engine oil temperature (EOT) sensor harness connector.
2. Turn ignition switch ON.
3. Check the voltage between EOT sensor harness connector and ground.

| EOT sensor |          | Ground | Voltage (V) |
|------------|----------|--------|-------------|
| Connector  | Terminal |        |             |
| F38        | 1        | Ground | Approx. 5   |

Is the inspection result normal?

- YES >> GO TO 3.  
NO >> Repair open circuit, short to ground or short to power in harness or connectors.

#### 3. CHECK EOT SENSOR GROUND CIRCUIT FOR OPEN AND SHORT

1. Turn ignition switch OFF.
2. Disconnect ECM harness connector.
3. Check the continuity between EOT sensor harness connector and ECM harness connector.

# P0197, P0198 EOT SENSOR

[VQ37VHR FOR USA AND CANADA]

< DTC/CIRCUIT DIAGNOSIS >

| EOT sensor |          | ECM       |          | Continuity |
|------------|----------|-----------|----------|------------|
| Connector  | Terminal | Connector | Terminal |            |
| F38        | 2        | F102      | 84       | Existed    |

4. Also check harness for short to ground and short to power.

Is the inspection result normal?

YES >> GO TO 4.

NO >> Repair open circuit, short to ground or short to power in harness or connectors.

## 4.CHECK ENGINE OIL TEMPERATURE SENSOR

Refer to [EC-299, "Component Inspection"](#).

Is the inspection result normal?

YES >> GO TO 5.

NO >> Replace engine oil temperature sensor. Refer to [EM-45, "Exploded View"](#).

## 5.CHECK INTERMITTENT INCIDENT

Refer to [GI-44, "Intermittent Incident"](#).

>> INSPECTION END

## Component Inspection

INFOID:000000006882952

## 1.CHECK ENGINE OIL TEMPERATURE SENSOR

1. Turn ignition switch OFF.
2. Disconnect engine oil temperature sensor harness connector.
3. Remove engine oil temperature sensor. Refer to [EM-45, "Exploded View"](#).
4. Check resistance between engine oil temperature sensor terminals by heating with hot water as shown in the figure.

| Terminals | Condition            | Resistance (kΩ) |               |
|-----------|----------------------|-----------------|---------------|
| 1 and 2   | Temperature °C (°F)] | 20 (68)         | 2.10 - 2.90   |
|           |                      | 50 (122)        | 0.68 - 1.00   |
|           |                      | 90 (194)        | 0.236 - 0.260 |

Is the inspection result normal?

YES >> INSPECTION END

NO >> Replace engine oil temperature sensor. Refer to [EM-45, "Exploded View"](#).

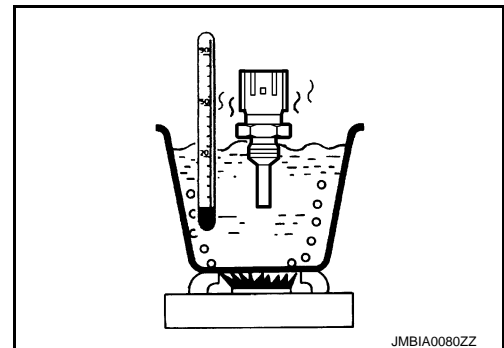

# P0222, P0223, P2132, P2133 TP SENSOR

< DTC/CIRCUIT DIAGNOSIS >

[VQ37VHR FOR USA AND CANADA]

## P0222, P0223, P2132, P2133 TP SENSOR

### DTC Logic

INFOID:000000006882953

#### DTC DETECTION LOGIC

##### NOTE:

If DTC P0222, P0223, P2132 or P2133 is displayed with DTC P0643, first perform the trouble diagnosis for DTC P0643. Refer to [EC-388, "DTC Logic"](#).

| DTC No. | Trouble diagnosis name                                 | DTC detecting condition  | Possible cause   |
|---------|--|--|--|
| P0222   | Throttle position sensor 1 (bank 1) circuit low input  | An excessively low voltage from the TP sensor 1 is sent to ECM.  | <ul style="list-style-type: none"><li>• Harness or connectors (TP sensor 1 circuit is open or shorted.)</li><li>• Electric throttle control actuator (TP sensor 1)</li></ul> |
| P0223   | Throttle position sensor 1 (bank 1) circuit high input | An excessively high voltage from the TP sensor 1 is sent to ECM. |  |
| P2132   | Throttle position sensor 1 (bank 2) circuit low input  | An excessively low voltage from the TP sensor 1 is sent to ECM.  |  |
| P2133   | Throttle position sensor 1 (bank 2) circuit high input | An excessively high voltage from the TP sensor 1 is sent to ECM. |  |

#### DTC CONFIRMATION PROCEDURE

##### 1. PRECONDITIONING

If DTC Confirmation Procedure has been previously conducted, always perform the following procedure before conducting the next test.

1. Turn ignition switch OFF and wait at least 10 seconds.
2. Turn ignition switch ON.
3. Turn ignition switch OFF and wait at least 10 seconds.

##### TESTING CONDITION:

Before performing the following procedure, confirm that battery voltage is more than 10 V at idle.

>> GO TO 2.

##### 2. PERFORM DTC CONFIRMATION PROCEDURE

1. Start engine and let it idle for 1 second.
2. Check DTC.

Is DTC detected?

YES >> Go to [EC-300, "Diagnosis Procedure"](#).

NO >> INSPECTION END

#### Diagnosis Procedure

INFOID:000000006882954

##### 1. CHECK GROUND CONNECTION

1. Turn ignition switch OFF.
2. Check ground connection M95. Refer to Ground Inspection in [GI-47, "Circuit Inspection"](#).

Is the inspection result normal?

YES >> GO TO 2.

NO >> Repair or replace ground connection.

##### 2. CHECK THROTTLE POSITION SENSOR 1 POWER SUPPLY CIRCUIT

1. Disconnect electric throttle control actuator harness connector.
2. Turn ignition switch ON.
3. Check the voltage between electric throttle control actuator harness connector and ground.

# P0222, P0223, P2132, P2133 TP SENSOR

< DTC/CIRCUIT DIAGNOSIS >

[VQ37VHR FOR USA AND CANADA]

| DTC          | Electric throttle control actuator |           |          | Ground | Voltage (V) |
|--------------|------------------------------------|-----------|----------|--------|-------------|
|              | Bank                               | Connector | Terminal |        |             |
| P0222, P0223 | 1                                  | F67       | 6        | Ground | Approx. 5   |
| P2132, P2133 | 2                                  | F27       | 1        |        |             |

Is the inspection result normal?

YES >> GO TO 3.

NO >> Repair open circuit, short to ground or short to power in harness or connectors.

## 3. CHECK THROTTLE POSITION SENSOR 1 GROUND CIRCUIT FOR OPEN AND SHORT

1. Turn ignition switch OFF.
2. Disconnect ECM harness connector.
3. Check the continuity between electric throttle control actuator harness connector and ECM harness connector.

| DTC          | Electric throttle control actuator |           |          | ECM       |          | Continuity |
|--------------|------------------------------------|-----------|----------|-----------|----------|------------|
|              | Bank                               | Connector | Terminal | Connector | Terminal |            |
| P0222, P0223 | 1                                  | F67       | 3        | F101      | 40       | Existed    |
| P2132, P2133 | 2                                  | F27       | 4        |           | 48       |            |

4. Also check harness for short to ground and short to power.

Is the inspection result normal?

YES >> GO TO 4.

NO >> Repair open circuit, short to ground or short to power in harness or connectors.

## 4. CHECK THROTTLE POSITION SENSOR 1 INPUT SIGNAL CIRCUIT FOR OPEN AND SHORT

1. Check the continuity between electric throttle control actuator harness connector and ECM harness connector.

| DTC          | Electric throttle control actuator |           |          | ECM       |          | Continuity |
|--------------|------------------------------------|-----------|----------|-----------|----------|------------|
|              | Bank                               | Connector | Terminal | Connector | Terminal |            |
| P0222, P0223 | 1                                  | F67       | 4        | F101      | 30       | Existed    |
| P2132, P2133 | 2                                  | F27       | 2        |           | 31       |            |

2. Also check harness for short to ground and short to power.

Is the inspection result normal?

YES >> GO TO 5.

NO >> Repair open circuit, short to ground or short to power in harness or connectors.

## 5. CHECK THROTTLE POSITION SENSOR

Refer to [EC-302, "Component Inspection"](#).

Is the inspection result normal?

YES >> GO TO 7.

NO >> GO TO 6.

## 6. REPLACE ELECTRIC THROTTLE CONTROL ACTUATOR

1. Replace malfunctioning electric throttle control actuator.
2. Go to [EC-302, "Special Repair Requirement"](#).

>> INSPECTION END

## 7. CHECK INTERMITTENT INCIDENT

Refer to [GI-44, "Intermittent Incident"](#).

>> INSPECTION END

# P0222, P0223, P2132, P2133 TP SENSOR

< DTC/CIRCUIT DIAGNOSIS >

[VQ37VHR FOR USA AND CANADA]

## Component Inspection

INFOID:000000006882955

### 1. CHECK THROTTLE POSITION SENSOR

1. Turn ignition switch OFF.
2. Reconnect all harness connectors disconnected.
3. Perform [EC-148, "Work Procedure"](#).
4. Turn ignition switch ON.
5. Set selector lever to D position.
6. Check the voltage between ECM harness connector terminals under the following conditions.

| ECM       |                           |    | Condition       | Voltage (V)    |
|-----------|---------------------------|----|-----------------|----------------|
| Connector | +                         | -  |                 |                |
|           | Terminal                  |    |                 |                |
| F101      | 30 [TP sensor 1 (bank 1)] | 40 | Fully released  | More than 0.36 |
|           |                           |    | Fully depressed | Less than 4.75 |
|           | 31 [TP sensor 1 (bank 2)] | 48 | Fully released  | More than 0.36 |
|           |                           |    | Fully depressed | Less than 4.75 |
|           | 34 [TP sensor 2 (bank 1)] | 40 | Fully released  | Less than 4.75 |
|           |                           |    | Fully depressed | More than 0.36 |
|           | 35 [TP sensor 2 (bank 2)] | 48 | Fully released  | Less than 4.75 |
|           |                           |    | Fully depressed | More than 0.36 |

Is the inspection result normal?

YES >> INSPECTION END

NO >> GO TO 2.

### 2. REPLACE ELECTRIC THROTTLE CONTROL ACTUATOR

1. Replace malfunctioning electric throttle control actuator.
2. Go to [EC-302, "Special Repair Requirement"](#).

>> INSPECTION END

## Special Repair Requirement

INFOID:000000006882956

### 1. PERFORM THROTTLE VALVE CLOSED POSITION LEARNING

Refer to [EC-148, "Work Procedure"](#)

>> GO TO 2.

### 2. PERFORM IDLE AIR VOLUME LEARNING

Refer to [EC-149, "Work Procedure"](#)

>> END

# P0300, P0301, P0302, P0303, P0304, P0305, P0306 MISFIRE

< DTC/CIRCUIT DIAGNOSIS >

[VQ37VHR FOR USA AND CANADA]

## P0300, P0301, P0302, P0303, P0304, P0305, P0306 MISFIRE

### DTC Logic

INFOID:000000006882957

#### DTC DETECTION LOGIC

When a misfire occurs, engine speed will fluctuate. If the engine speed fluctuates enough to cause the crankshaft position (CKP) sensor (POS) signal to vary, ECM can determine that a misfire is occurring.

| Sensor                           | Input signal to ECM | ECM function                  |
|----------------------------------|---------------------|-------------------------------|
| Crankshaft position sensor (POS) | Engine speed        | On board diagnosis of misfire |

The misfire detection logic consists of the following two conditions.

- One Trip Detection Logic (Three Way Catalyst Damage)**  
On the 1st trip, when a misfire condition occurs that can damage the three way catalyst (TWC) due to overheating, the MIL will blink.  
When a misfire condition occurs, the ECM monitors the CKP sensor signal every 200 engine revolutions for a change.  
When the misfire condition decreases to a level that will not damage the TWC, the MIL will turn off.  
If another misfire condition occurs that can damage the TWC on a second trip, the MIL will blink.  
When the misfire condition decreases to a level that will not damage the TWC, the MIL will remain illuminating.  
If another misfire condition occurs that can damage the TWC, the MIL will begin to blink again.
- Two Trip Detection Logic (Exhaust quality deterioration)**  
For misfire conditions that will not damage the TWC (but will affect vehicle emissions), the MIL will only illuminate when the misfire is detected on a second trip. During this condition, the ECM monitors the CKP sensor signal every 1,000 engine revolutions.  
A misfire malfunction can be detected in any one cylinder or in multiple cylinders.

| DTC No. | Trouble diagnosis name              | DTC detecting condition     | Possible cause  |
|---------|-------------------------------------|-----------------------------|---|
| P0300   | Multiple cylinder misfires detected | Multiple cylinders misfire. | <ul style="list-style-type: none"><li>• Improper spark plug</li><li>• Insufficient compression</li><li>• Incorrect fuel pressure</li><li>• The fuel injector circuit is open or shorted</li><li>• Fuel injector</li><li>• Intake air leak</li><li>• The ignition signal circuit is open or shorted</li><li>• Lack of fuel</li><li>• Signal plate</li><li>• A/F sensor 1</li><li>• Incorrect PCV hose connection</li></ul> |
| P0301   | No.1 cylinder misfire detected      | No. 1 cylinder misfires.    |   |
| P0302   | No. 2 cylinder misfire detected     | No. 2 cylinder misfires.    |   |
| P0303   | No. 3 cylinder misfire detected     | No. 3 cylinder misfires.    |   |
| P0304   | No. 4 cylinder misfire detected     | No. 4 cylinder misfires.    |   |
| P0305   | No. 5 cylinder misfire detected     | No. 5 cylinder misfires.    |   |
| P0306   | No. 6 cylinder misfire detected     | No. 6 cylinder misfires.    |   |

#### DTC CONFIRMATION PROCEDURE

##### 1. PRECONDITIONING

If DTC Confirmation Procedure has been previously conducted, always perform the following procedure before conducting the next test.

1. Turn ignition switch OFF and wait at least 10 seconds.
2. Turn ignition switch ON.
3. Turn ignition switch OFF and wait at least 10 seconds.

>> GO TO 2.

##### 2. PERFORM DTC CONFIRMATION PROCEDURE-I

1. Start engine and warm it up to normal operating temperature.
2. Turn ignition switch OFF and wait at least 10 seconds.
3. Turn ignition switch ON.
4. Turn ignition switch OFF and wait at least 10 seconds.
5. Restart engine and let it idle for about 15 minutes.
6. Check 1st trip DTC.

Is 1st trip DTC detected?

# P0300, P0301, P0302, P0303, P0304, P0305, P0306 MISFIRE

< DTC/CIRCUIT DIAGNOSIS >

[VQ37VHR FOR USA AND CANADA]

- YES >> Go to [EC-304, "Diagnosis Procedure"](#).  
NO >> GO TO 3.

## 3.PERFORM DTC CONFIRMATION PROCEDURE-II

1. Turn ignition switch OFF and wait at least 10 seconds.
2. Turn ignition switch ON.
3. Turn ignition switch OFF and wait at least 10 seconds.
4. Start engine and drive the vehicle under similar conditions to (1st trip) Freeze Frame Data for a certain time. Refer to the table below.

**Hold the accelerator pedal as steady as possible.**

Similar conditions to (1st trip) Freeze Frame Data mean that the following conditions should be satisfied at the same time.

**CAUTION:**

**Always drive vehicle in safe manner according to traffic conditions and obey all traffic laws when driving.**

|  |  |
|--|--|
| Engine speed                             | Engine speed in the freeze frame data $\pm$ 400 rpm  |
| Vehicle speed                            | Vehicle speed in the freeze frame data $\pm$ 10 km/h (6 MPH)   |
| Base fuel schedule                       | Base fuel schedule in the freeze frame data $\times$ (1 $\pm$ 0.1)   |
| Engine coolant temperature (T) condition | When the freeze frame data shows lower than 70 °C (158 °F), T should be lower than 70 °C (158 °F).<br>When the freeze frame data shows higher than or equal to 70 °C (158 °F), T should be higher than or equal to 70 °C (158 °F). |

Driving time varies according to the engine speed in the freeze frame data.

| Engine speed        | Time                      |
|---------------------|---------------------------|
| Around 1,000 rpm    | Approximately 10 minutes  |
| Around 2,000 rpm    | Approximately 5 minutes   |
| More than 3,000 rpm | Approximately 3.5 minutes |

5. Check 1st trip DTC.

Is 1st trip DTC detected?

- YES >> Go to [EC-304, "Diagnosis Procedure"](#).  
NO >> INSPECTION END

## Diagnosis Procedure

INFOID:000000006882958

### 1.CHECK FOR INTAKE AIR LEAK AND PCV HOSE

1. Start engine and run it at idle speed.
2. Listen for the sound of the intake air leak.
3. Check PCV hose connection.

Is intake air leak detected?

- YES >> Discover air leak location and repair.  
NO >> GO TO 2.

### 2.CHECK FOR EXHAUST SYSTEM CLOGGING

Stop engine and visually check exhaust tube, three way catalyst and muffler for dents.

Is the inspection result normal?

- YES-1 >> With CONSULT: GO TO 3.  
YES-2 >> Without CONSULT: GO TO 4.  
NO >> Repair or replace it.

### 3.PERFORM POWER BALANCE TEST

**Ⓟ With CONSULT**

1. Start engine.
2. Perform "POWER BALANCE" in "ACTIVE TEST" mode with CONSULT.



# P0300, P0301, P0302, P0303, P0304, P0305, P0306 MISFIRE

[VQ37VHR FOR USA AND CANADA]

## < DTC/CIRCUIT DIAGNOSIS >

3. Make sure that each circuit produces a momentary engine speed drop.

Is the inspection result normal?

YES >> GO TO 9.

NO >> GO TO 4.

## 4. CHECK FUNCTION OF FUEL INJECTOR-I

1. Start engine and let it idle.
2. Listen to each fuel injector operation sound.

**Clicking sound should be heard.**

Is the inspection result normal?

YES >> GO TO 5.

NO >> Perform trouble diagnosis for FUEL INJECTOR, refer to [EC-512. "Diagnosis Procedure"](#).

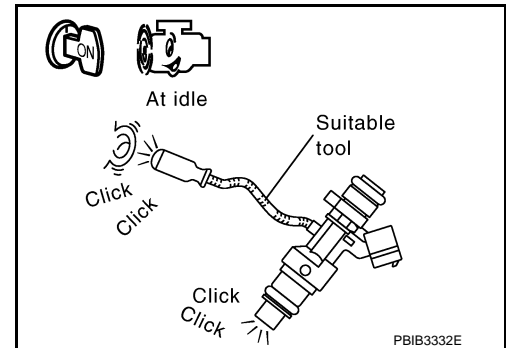

## 5. CHECK FUNCTION OF IGNITION COIL-I

### CAUTION:

Perform the following procedure in a place where with no combustible objects and good ventilation.

1. Turn ignition switch OFF.
2. Remove fuel pump fuse (1) in IPDM E/R (2) to release fuel pressure.

### NOTE:

Do not use CONSULT to release fuel pressure, or fuel pressure applies again during the following procedure.

3. Start engine.
4. After engine stalls, crank it two or three times to release all fuel pressure.
5. Turn ignition switch OFF.
6. Remove all ignition coil harness connectors to avoid the electrical discharge from the ignition coils.
7. Remove ignition coil and spark plug of the cylinder to be checked.
8. Crank engine for 5 seconds or more to remove combustion gas in the cylinder.
9. Connect spark plug and harness connector to ignition coil.
10. Fix ignition coil using a rope etc. with gap of 13 - 17 mm (0.52 - 0.66 in) between the edge of the spark plug and grounded metal portion as shown in the figure.
11. Crank engine for about 3 seconds, and check whether spark is generated between the spark plug and the grounded metal portion.

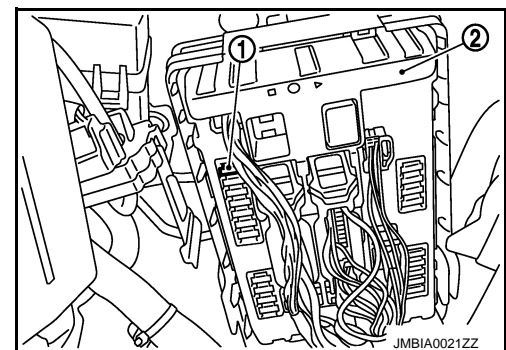

**Spark should be generated.**

### CAUTION:

- Never place the spark plug and the ignition coil within 50 cm (19.7 in) each other. Be careful not to get an electrical shock while checking, because the electrical discharge voltage becomes 20 kV or more.
- It might damage the ignition coil if the gap of more than 17 mm (0.66 in) is made.

### NOTE:

When the gap is less than 13 mm (0.52 in), a spark might be generated even if the coil is malfunctioning.

Is the inspection result normal?

YES >> GO TO 9.

NO >> GO TO 6.

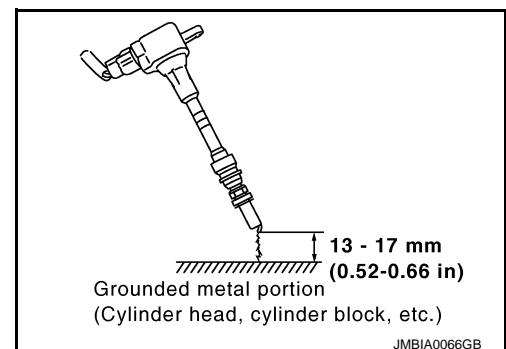

**6. CHECK FUNCTION OF IGNITION COIL-II**

1. Turn ignition switch OFF.
2. Disconnect spark plug and connect a non-malfunctioning spark plug.
3. Crank engine for about 3 seconds, and recheck whether spark is generated between the spark plug and the grounded metal portion.

**Spark should be generated.**

Is the inspection result normal?

YES >> GO TO 7.

NO >> Check ignition coil, power transistor and their circuits. Refer to [EC-519. "Diagnosis Procedure"](#).

**7. CHECK SPARK PLUG**

Check the initial spark plug for fouling, etc.

Is the inspection result normal?

YES >> Replace spark plug(s) with standard type one(s). For spark plug type, refer to [EM-26. "Inspection"](#).

NO >> Repair or clean spark plug. Then GO TO 8.

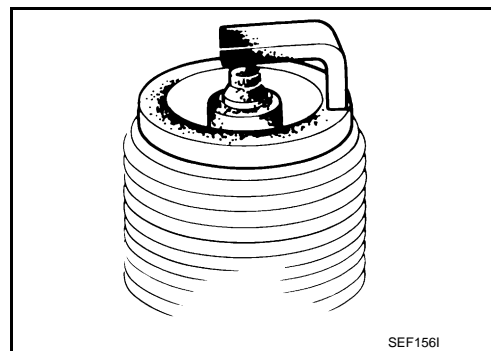
**8. CHECK FUNCTION OF IGNITION COIL-III**

1. Reconnect the initial spark plugs.
2. Crank engine for about 3 seconds, and recheck whether spark is generated between the spark plug and the grounded portion.

**Spark should be generated.**

Is the inspection result normal?

YES >> INSPECTION END

NO >> Replace spark plug(s) with standard type one(s). For spark plug type, refer to [EM-25. "Removal and Installation"](#).

**9. CHECK COMPRESSION PRESSURE**

Check compression pressure. Refer to [EM-18. "Inspection"](#).

Is the inspection result normal?

YES >> GO TO 10.

NO >> Check pistons, piston rings, valves, valve seats and cylinder head gaskets.

**10. CHECK FUEL PRESSURE**

1. Install all removed parts.
2. Release fuel pressure to zero. Refer to [EC-158. "Work Procedure"](#).
3. Install fuel pressure gauge and check fuel pressure. Refer to [EC-158. "Work Procedure"](#).

**At idle: Approximately 350 kPa (3.57 kg/cm<sup>2</sup>, 51 psi)**

Is the inspection result normal?

YES >> GO TO 12.

NO >> GO TO 11.

**11. DETECT MALFUNCTIONING PART**

Check fuel hoses and fuel tubes for clogging.

Is the inspection result normal?

YES >> Replace "fuel filter and fuel pump assembly".

NO >> Repair or replace.

# P0300, P0301, P0302, P0303, P0304, P0305, P0306 MISFIRE

< DTC/CIRCUIT DIAGNOSIS >

[VQ37VHR FOR USA AND CANADA]

## 12.CHECK IDLE SPEED AND IGNITION TIMING

For procedure, refer to [EC-154, "Work Procedure"](#).

For specification, refer to [EC-545, "Idle Speed"](#) and [EC-545, "Ignition Timing"](#).

Is the inspection result normal?

YES >> GO TO 13.

NO >> Follow the [EC-154, "Work Procedure"](#).

## 13.CHECK A/F SENSOR 1 INPUT SIGNAL CIRCUIT

1. Turn ignition switch OFF.
2. Disconnect corresponding A/F sensor 1 harness connector.
3. Disconnect ECM harness connector.
4. Check the continuity between A/F sensor 1 harness connector and ECM harness connector.

| A/F sensor 1 |           |          | ECM       |          | Continuity |
|--------------|-----------|----------|-----------|----------|------------|
| Bank         | Connector | Terminal | Connector | Terminal |            |
| 1            | F3        | 1        | F102      | 57       | Existed    |
|              |           | 2        |           | 61       |            |
| 2            | F20       | 1        |           | 65       |            |
|              |           | 2        |           | 66       |            |

5. Check the continuity between A/F sensor 1 harness connector and ground, or ECM harness connector and ground.

| A/F sensor 1 |           |          | Ground | Continuity  |
|--------------|-----------|----------|--------|-------------|
| Bank         | Connector | Terminal |        |             |
| 1            | F3        | 1        | Ground | Not existed |
|              |           | 2        |        |             |
| 2            | F20       | 1        |        |             |
|              |           | 2        |        |             |

| ECM  |           |          | Ground | Continuity  |
|------|-----------|----------|--------|-------------|
| Bank | Connector | Terminal |        |             |
| 1    | F102      | 57       | Ground | Not existed |
|      |           | 61       |        |             |
| 65   |           |          |        |             |
| 66   |           |          |        |             |

6. Also check harness for short to power.

Is the inspection result normal?

YES >> GO TO 14.

NO >> Repair open circuit, short to ground or short to power in harness or connectors.

## 14.CHECK A/F SENSOR 1 HEATER

Refer to [EC-197, "Component Inspection"](#).

Is the inspection result normal?

YES >> GO TO 15.

NO >> Replace (malfunctioning) A/F sensor 1. Refer to [EM-36, "Exploded View"](#).

## 15.CHECK MASS AIR FLOW SENSOR

### With CONSULT

Check mass air flow sensor signal in "DATA MONITOR" mode with CONSULT.

For specification, refer to [EC-545, "Mass Air Flow Sensor"](#).

### With GST

## P0300, P0301, P0302, P0303, P0304, P0305, P0306 MISFIRE

< DTC/CIRCUIT DIAGNOSIS >

[VQ37VHR FOR USA AND CANADA]

---

Check mass air flow sensor signal in Service \$01 with GST.

For specification, refer to [EC-545, "Mass Air Flow Sensor"](#).

Is the measurement value within the specification?

YES >> GO TO 16.

NO >> Check connectors for rusted terminals or loose connections in the mass air flow sensor circuit or ground. Refer to [EC-211, "Diagnosis Procedure"](#).

### 16.CHECK SYMPTOM TABLE

---

Check items on the rough idle symptom in [EC-532, "Symptom Table"](#).

Is the inspection result normal?

YES >> GO TO 17.

NO >> Repair or replace.

### 17.ERASE THE 1ST TRIP DTC

---

Some tests may cause a 1st trip DTC to be set.

Erase the 1st trip DTC from the ECM memory after performing the tests. Refer to [EC-85, "On Board Diagnosis Function"](#) (Without CONSULT) or [EC-88, "CONSULT Function"](#) (With CONSULT).

>> GO TO 18.

### 18.CHECK INTERMITTENT INCIDENT

---

Refer to [GI-44, "Intermittent Incident"](#).

>> INSPECTION END

P0327, P0328, P0332, P0333 KS

DTC Logic

INFOID:000000006882959

DTC DETECTION LOGIC

A  
EC

| DTC No. | Trouble diagnosis name                   | DTC detected condition                                      | Possible cause   |
|---------|--|---|--|
| P0327   | Knock sensor (bank 1) circuit low input  | An excessively low voltage from the sensor is sent to ECM.  | <ul style="list-style-type: none"> <li>• Harness or connectors (The sensor circuit is open or shorted.)</li> <li>• Knock sensor</li> </ul> |
| P0328   | Knock sensor (bank 1) circuit high input | An excessively high voltage from the sensor is sent to ECM. |  |
| P0332   | Knock sensor (bank 2) circuit low input  | An excessively low voltage from the sensor is sent to ECM.  |  |
| P0333   | Knock sensor (bank 2) circuit high input | An excessively high voltage from the sensor is sent to ECM. |  |

C  
D  
E

DTC CONFIRMATION PROCEDURE

1. PRECONDITIONING

If DTC Confirmation Procedure has been previously conducted, always perform the following procedure before conducting the next test.

1. Turn ignition switch OFF and wait at least 10 seconds.
2. Turn ignition switch ON.
3. Turn ignition switch OFF and wait at least 10 seconds.

**TESTING CONDITION:**

**Before performing the following procedure, confirm that battery voltage is more than 10 V at idle.**

>> GO TO 2.

2. PERFORM DTC CONFIRMATION PROCEDURE

1. Start engine and run it for at least 5 seconds at idle speed.
2. Check 1st trip DTC.

Is 1st trip DTC detected?

- YES >> Go to [EC-309, "Diagnosis Procedure"](#).
- NO >> INSPECTION END

Diagnosis Procedure

INFOID:000000006882960

1. CHECK GROUND CONNECTION

1. Turn ignition switch OFF.
2. Check ground connection M95. Refer to Ground Inspection in [GI-47, "Circuit Inspection"](#).

Is the inspection result normal?

- YES >> GO TO 2.
- NO >> Repair or replace ground connection.

2. CHECK KNOCK SENSOR GROUND CIRCUIT FOR OPEN AND SHORT

1. Disconnect knock sensor harness connector and ECM harness connector.
2. Check the continuity between knock sensor harness connector and ECM harness connector.

| DTC          | Knock sensor |           |          | ECM       |          | Continuity |
|--------------|--------------|-----------|----------|-----------|----------|------------|
|              | Bank         | Connector | Terminal | Connector | Terminal |            |
| P0327, P0328 | 1            | F203      | 2        | F102      | 72       | Existed    |
| P0332, P0333 | 2            | F202      | 2        |           |          |            |

3. Also check harness for short to ground and short to power.

Is the inspection result normal?

F  
G  
H  
I  
J  
K  
L  
M  
N  
O  
P

< DTC/CIRCUIT DIAGNOSIS >

- YES >> GO TO 4.
- NO >> GO TO 3.

**3. DETECT MALFUNCTIONING PART**

Check the following.

- Harness connectors F9, F201
- Harness for open or short between knock sensor and ECM

>> Repair open circuit or short to power in harness or connectors.

**4. CHECK KNOCK SENSOR INPUT SIGNAL CIRCUIT FOR OPEN AND SHORT**

1. Check the continuity between knock sensor harness connector and ECM harness connector.

| DTC          | Knock sensor |           |          | ECM       |          | Continuity |
|--------------|--------------|-----------|----------|-----------|----------|------------|
|              | Bank         | Connector | Terminal | Connector | Terminal |            |
| P0327, P0328 | 1            | F203      | 1        | F102      | 73       | Existed    |
| P0332, P0333 | 2            | F202      | 1        |           | 69       |            |

2. Also check harness for short to ground and short to power.

Is the inspection result normal?

- YES >> GO TO 6.
- NO >> GO TO 5.

**5. DETECT MALFUNCTIONING PART**

Check the following.

- Harness connectors F9, F201
- Harness for open or short between ECM and knock sensor

>> Repair open circuit, short to ground or short to power in harness or connectors.

**6. CHECK KNOCK SENSOR**

Refer to [EC-310, "Component Inspection"](#).

Is the inspection result normal?

- YES >> GO TO 7.
- NO >> Replace malfunctioning knock sensor. Refer to [EM-123, "Exploded View"](#).

**7. CHECK INTERMITTENT INCIDENT**

Refer to [GI-44, "Intermittent Incident"](#).

>> INSPECTION END

**Component Inspection**

INFOID:000000006882961

**1. CHECK KNOCK SENSOR**

1. Turn ignition switch OFF.
2. Disconnect knock sensor harness connector.
3. Check resistance between knock sensor terminals as per the following.

**NOTE:**

**It is necessary to use an ohmmeter which can measure more than 10 MΩ.**

| Terminals | Resistance (kΩ)                    |
|-----------|------------------------------------|
| 1 and 2   | Approx. 532 - 588 [at 20°C (68°F)] |

**CAUTION:**

**Do not use any knock sensors that have been dropped or physically damaged. Use only new ones.**

Is the inspection result normal?

- YES >> INSPECTION END

**P0327, P0328, P0332, P0333 KS**

< DTC/CIRCUIT DIAGNOSIS >

**[VQ37VHR FOR USA AND CANADA]**

---

NO >> Replace malfunctioning knock sensor. Refer to [EM-123. "Exploded View"](#).

A

**EC**

C

D

E

F

G

H

I

J

K

L

M

N

O

P

# P0335 CKP SENSOR (POS)

< DTC/CIRCUIT DIAGNOSIS >

[VQ37VHR FOR USA AND CANADA]

## P0335 CKP SENSOR (POS)

### DTC Logic

INFOID:000000006882962

### DTC DETECTION LOGIC

| DTC No. | Trouble diagnosis name                   | DTC detecting condition   | Possible cause  |
|---------|--|---|---|
| P0335   | Crankshaft position sensor (POS) circuit | <ul style="list-style-type: none"><li>• The crankshaft position sensor (POS) signal is not detected by the ECM during the first few seconds of engine cranking.</li><li>• The proper pulse signal from the crankshaft position sensor (POS) is not sent to ECM while the engine is running.</li><li>• The crankshaft position sensor (POS) signal is not in the normal pattern during engine running.</li></ul> | <ul style="list-style-type: none"><li>• Harness or connectors [CKP sensor (POS) circuit is open or shorted.] [CMP sensor (PHASE) (bank 2) circuit is open or shorted.] (APP sensor 2 circuit is shorted.) (EVAP control system pressure sensor circuit is shorted.) (Battery current sensor circuit is shorted.) (Refrigerant pressure sensor circuit is shorted.)</li><li>• Crankshaft position sensor (POS)</li><li>• Camshaft position sensor (PHASE) (bank 2)</li><li>• Accelerator pedal position sensor</li><li>• EVAP control system pressure sensor</li><li>• Battery current sensor</li><li>• Refrigerant pressure sensor</li><li>• Signal plate</li></ul> |

### DTC CONFIRMATION PROCEDURE

#### 1. PRECONDITIONING

If DTC Confirmation Procedure has been previously conducted, always perform the following procedure before conducting the next test.

1. Turn ignition switch OFF and wait at least 10 seconds.
2. Turn ignition switch ON.
3. Turn ignition switch OFF and wait at least 10 seconds.

#### TESTING CONDITION:

**Before performing the following procedure, confirm that battery voltage is more than 10.5 V with ignition switch ON.**

>> GO TO 2.

#### 2. PERFORM DTC CONFIRMATION PROCEDURE

1. Start engine and let it idle for at least 5 seconds.  
If engine does not start, crank engine for at least 2 seconds.
2. Check 1st trip DTC.

Is 1st trip DTC detected?

YES >> Go to [EC-312, "Diagnosis Procedure"](#).

NO >> INSPECTION END

### Diagnosis Procedure

INFOID:000000006882963

#### 1. CHECK GROUND CONNECTION

1. Turn ignition switch OFF.
2. Check ground connection M95. Refer to Ground Inspection in [GI-47, "Circuit Inspection"](#).

Is the inspection result normal?

YES >> GO TO 2.

NO >> Repair or replace ground connection.

#### 2. CHECK CRANKSHAFT POSITION (CKP) SENSOR (POS) POWER SUPPLY CIRCUIT-I

1. Disconnect crankshaft position (CKP) sensor (POS) harness connector.
2. Turn ignition switch ON.
3. Check the voltage between CKP sensor (POS) harness connector and ground.



# P0335 CKP SENSOR (POS)

[VQ37VHR FOR USA AND CANADA]

< DTC/CIRCUIT DIAGNOSIS >

| CKP sensor (POS) |          | Ground | Voltage (V) |
|------------------|----------|--------|-------------|
| Connector        | Terminal |        |             |
| F2               | 1        | Ground | Approx. 5   |

Is the inspection result normal?

YES >> GO TO 8.

NO >> GO TO 3.

## 3. CHECK CRANKSHAFT POSITION (CKP) SENSOR (POS) POWER SUPPLY CIRCUIT-II

1. Turn ignition switch ON.
2. Disconnect ECM harness connector.
3. Check the continuity between CKP sensor (POS) harness connector and ECM harness connector.

| CKP sensor (POS) |          | ECM       |          | Continuity |
|------------------|----------|-----------|----------|------------|
| Connector        | Terminal | Connector | Terminal |            |
| F2               | 1        | F101      | 46       | Existed    |

Is the inspection result normal?

YES >> GO TO 4.

NO >> Repair open circuit.

## 4. CHECK SENSOR POWER SUPPLY CIRCUIT

Check harness for short to power and short to ground, between the following terminals.

| ECM       |          | Sensor                              |  |                                    |
|-----------|----------|-------------------------------------|--|------------------------------------|
| Connector | Terminal | Name                                | Connector                              | Terminal                           |
| F101      | 46       | CKP sensor (POS)                    | F2                                     | 1                                  |
| F102      | 64       | CMP sensor (PHASE) (bank 2)         | F18                                    | 1                                  |
|           |          | Battery current sensor              | E21                                    |                                    |
| M107      | 103      | APP sensor                          | M153 <sup>*1</sup><br>M9 <sup>*2</sup> | 3 <sup>*1</sup><br>6 <sup>*2</sup> |
|           | 107      | EVAP control system pressure sensor | B73                                    | 3                                  |
|           |          | Refrigerant pressure sensor         | E77                                    | 3                                  |

\*1: With ICC

\*2: Without ICC

Is the inspection result normal?

YES >> GO TO 5.

NO >> Repair short to ground or short to power in harness or connectors.

## 5. CHECK COMPONENTS

Check the following.

- Camshaft position sensor (PHASE) (bank 2) (Refer to [EC-319, "Component Inspection"](#).)
- Battery current sensor (Refer to [EC-437, "Component Inspection"](#).)
- EVAP control system pressure sensor (Refer to [EC-349, "Component Inspection"](#).)
- Refrigerant pressure sensor (Refer to [EC-530, "Diagnosis Procedure"](#).)

Is the inspection result normal?

YES >> GO TO 6.

NO >> Replace malfunctioning component.

## 6. CHECK APP SENSOR

Refer to [EC-487, "Component Inspection"](#).

Is the inspection result normal?

YES >> GO TO 12.

# P0335 CKP SENSOR (POS)

[VQ37VHR FOR USA AND CANADA]

< DTC/CIRCUIT DIAGNOSIS >

NO >> GO TO 7.

## 7. REPLACE ACCELERATOR PEDAL ASSEMBLY

1. Replace accelerator pedal assembly.
2. Go to [EC-487, "Special Repair Requirement"](#).

>> INSPECTION END

## 8. CHECK CKP SENSOR (POS) GROUND CIRCUIT FOR OPEN AND SHORT

1. Turn ignition switch OFF.
2. Disconnect ECM harness connector.
3. Check the continuity between CKP sensor (POS) harness connector and ECM harness connector.

| CKP sensor (POS) |          | ECM       |          | Continuity |
|------------------|----------|-----------|----------|------------|
| Connector        | Terminal | Connector | Terminal |            |
| F2               | 2        | F101      | 47       | Existed    |

4. Also check harness for short to ground and short to power.

Is the inspection result normal?

YES >> GO TO 9.

NO >> Repair open circuit, short to ground or short to power in harness or connectors.

## 9. CHECK CKP SENSOR (POS) INPUT SIGNAL CIRCUIT FOR OPEN AND SHORT

1. Check the continuity between CKP sensor (POS) harness connector and ECM harness connector.

| CKP sensor (POS) |          | ECM       |          | Continuity |
|------------------|----------|-----------|----------|------------|
| Connector        | Terminal | Connector | Terminal |            |
| F2               | 3        | F101      | 37       | Existed    |

2. Also check harness for short to ground and short to power.

Is the inspection result normal?

YES >> GO TO 10.

NO >> Repair open circuit, short to ground or short to power in harness or connectors.

## 10. CHECK CRANKSHAFT POSITION SENSOR (POS)

Refer to [EC-314, "Component Inspection"](#).

Is the inspection result normal?

YES >> GO TO 11.

NO >> Replace crankshaft position sensor (POS). Refer to [EM-123, "Exploded View"](#).

## 11. CHECK GEAR TOOTH

Visually check for chipping signal plate gear tooth.

Is the inspection result normal?

YES >> GO TO 12.

NO >> Replace the signal plate. Refer to [EM-123, "Exploded View"](#).

## 12. CHECK INTERMITTENT INCIDENT

Refer to [GI-44, "Intermittent Incident"](#).

>> INSPECTION END

## Component Inspection

INFOID:000000006882964

### 1. CHECK CRANKSHAFT POSITION SENSOR (POS)-I

1. Turn ignition switch OFF.
2. Loosen the fixing bolt of the sensor.
3. Disconnect crankshaft position sensor (POS) harness connector.

# P0335 CKP SENSOR (POS)

[VQ37VHR FOR USA AND CANADA]

< DTC/CIRCUIT DIAGNOSIS >

- 4. Remove the sensor. Refer to [EM-123, "Exploded View"](#).
- 5. Visually check the sensor for chipping.

Is the inspection result normal?

YES >> GO TO 2.

NO >> Replace crankshaft position sensor (POS). Refer to [EM-123, "Exploded View"](#).

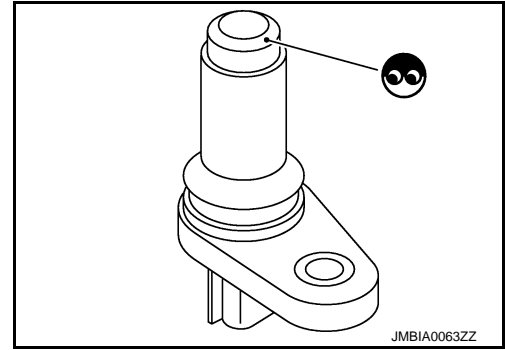

## 2. CHECK CRANKSHAFT POSITION SENSOR (POS)-II

Check resistance between crankshaft position sensor (POS) terminals as follows.

| Terminals (Polarity) | Resistance ( $\Omega$ )               |
|----------------------|---------------------------------------|
| 1 (+) - 2 (-)        | Except 0 or $\infty$ [at 25°C (77°F)] |
| 1 (+) - 3 (-)        |                                       |
| 2 (+) - 3 (-)        |                                       |

Is the inspection result normal?

YES >> INSPECTION END

NO >> Replace crankshaft position sensor (POS). Refer to [EM-123, "Exploded View"](#).

A  
EC  
C  
D  
E  
F  
G  
H  
I  
J  
K  
L  
M  
N  
O  
P

# P0340, P0345 CMP SENSOR (PHASE)

< DTC/CIRCUIT DIAGNOSIS >

[VQ37VHR FOR USA AND CANADA]

## P0340, P0345 CMP SENSOR (PHASE)

### DTC Logic

INFOID:000000006882965

#### DTC DETECTION LOGIC

##### NOTE:

If DTC P0340 or P0345 is displayed with DTC P0643, first perform the trouble diagnosis for DTC P0643. Refer to [EC-388, "DTC Logic"](#).

| DTC No. | Trouble diagnosis name                            | DTC detecting condition  | Possible cause  |
|---------|---|--|---|
| P0340   | Camshaft position sensor (PHASE) (bank 1) circuit |  | <ul style="list-style-type: none"><li>• Harness or connectors [CMP sensor (PHASE) (bank 1) circuit is open or shorted.]</li><li>• Camshaft position sensor (PHASE) (bank 1)</li><li>• Camshaft (INT)</li><li>• Starter motor</li><li>• Starting system circuit</li><li>• Dead (Weak) battery</li></ul>  |
| P0345   | Camshaft position sensor (PHASE) (bank 2) circuit | <ul style="list-style-type: none"><li>• The cylinder No. signal is not sent to ECM for the first few seconds during engine cranking.</li><li>• The cylinder No. signal is not sent to ECM during engine running.</li><li>• The cylinder No. signal is not in the normal pattern during engine running.</li></ul> | <ul style="list-style-type: none"><li>• Harness or connectors [CMP sensor (PHASE) (bank 2) circuit is open or shorted.] [CKP sensor (POS) circuit is open or shorted.] (APP sensor 2 circuit is shorted.) (EVAP control system pressure sensor circuit is shorted.) (Battery current sensor circuit is open or shorted.) (Refrigerant pressure sensor circuit is shorted.)</li><li>• Camshaft position sensor (PHASE) (bank 2)</li><li>• Crankshaft position sensor (POS)</li><li>• Accelerator pedal position sensor</li><li>• EVAP control system pressure sensor</li><li>• Battery current sensor</li><li>• Refrigerant pressure sensor</li><li>• Camshaft (INT)</li><li>• Starter motor</li><li>• Starting system circuit</li><li>• Dead (Weak) battery</li></ul> |

#### DTC CONFIRMATION PROCEDURE

##### 1. PRECONDITIONING

If DTC Confirmation Procedure has been previously conducted, always perform the following procedure before conducting the next test.

1. Turn ignition switch OFF and wait at least 10 seconds.
2. Turn ignition switch ON.
3. Turn ignition switch OFF and wait at least 10 seconds.

##### TESTING CONDITION:

Before performing the following procedure, confirm that battery voltage is more than 10.5 V with ignition switch ON.

>> GO TO 2.

##### 2. PERFORM DTC CONFIRMATION PROCEDURE-I

1. Start engine and let it idle for at least 5 seconds.  
If engine does not start, crank engine for at least 2 seconds.
2. Check 1st trip DTC.

Is 1st trip DTC detected?

YES >> Go to [EC-317, "Diagnosis Procedure"](#).

NO >> GO TO 3.

##### 3. PERFORM DTC CONFIRMATION PROCEDURE-II

1. Maintaining engine speed at more than 800 rpm for at least 5 seconds.
2. Check 1st trip DTC.

# P0340, P0345 CMP SENSOR (PHASE)

[VQ37VHR FOR USA AND CANADA]

< DTC/CIRCUIT DIAGNOSIS >

Is 1st trip DTC detected?

- YES >> Go to [EC-317, "Diagnosis Procedure"](#).
- NO >> INSPECTION END

## Diagnosis Procedure

INFOID:000000006882966

### 1. CHECK STARTING SYSTEM

Turn ignition switch to START position.

Does the engine turn over? Does the starter motor operate?

- YES >> GO TO 2.
- NO >> Check starting system. (Refer to [ST-11, "Work Flow \(Heated Steering Wheel\)"](#).)

### 2. CHECK GROUND CONNECTION

1. Turn ignition switch OFF.
2. Check ground connection M95. Refer to Ground Inspection in [GI-47, "Circuit Inspection"](#).

Is the inspection result normal?

- YES >> GO TO 3.
- NO >> Repair or replace ground connection.

### 3. CHECK CAMSHAFT POSITION (CMP) SENSOR (PHASE) POWER SUPPLY CIRCUIT-I

1. Disconnect camshaft position (CMP) sensor (PHASE) harness connector.
2. Turn ignition switch ON.
3. Check the voltage between CMP sensor (PHASE) harness connector and ground.

| DTC   | CMP sensor (PHASE) |           |          | Ground | Voltage (V) |
|-------|--------------------|-----------|----------|--------|-------------|
|       | Bank               | Connector | Terminal |        |             |
| P0340 | 1                  | F5        | 1        | Ground | Approx. 5   |
| P0345 | 2                  | F18       | 1        |        |             |

Is the inspection result normal?

- YES >> GO TO 9.
- NO-1 >> P0340: Repair open circuit, short to ground or short to power in harness or connectors.
- NO-2 >> P0345: GO TO 4.

### 4. CHECK CAMSHAFT POSITION (CMP) SENSOR (PHASE) POWER SUPPLY CIRCUIT-II

1. Turn ignition switch OFF.
2. Disconnect ECM harness connector.
3. Check the continuity between CMP sensor (PHASE) harness connector and ECM harness connector.

| CMP sensor (PHASE) |           |          | ECM       |          | Continuity |
|--------------------|-----------|----------|-----------|----------|------------|
| Bank               | Connector | Terminal | Connector | Terminal |            |
| 2                  | F18       | 1        | F102      | 64       | Existed    |

Is the inspection result normal?

- YES >> GO TO 5.
- NO >> Repair open circuit.

### 5. CHECK CAMSHAFT POSITION (CMP) SENSOR (PHASE) POWER SUPPLY CIRCUIT-III

Check harness for short to power and short to ground, between the following terminals.

| ECM       |          | Sensor                      |           |          |
|-----------|----------|-----------------------------|-----------|----------|
| Connector | Terminal | Name                        | Connector | Terminal |
| F101      | 46       | CKP sensor (POS)            | F2        | 1        |
| F102      | 64       | CMP sensor (PHASE) (bank 2) | F18       | 1        |
|           |          | Battery current sensor      | E21       |          |

# P0340, P0345 CMP SENSOR (PHASE)

< DTC/CIRCUIT DIAGNOSIS >

[VQ37VHR FOR USA AND CANADA]

| ECM       |          | Sensor                              |                |            |
|-----------|----------|-------------------------------------|----------------|------------|
| Connector | Terminal | Name                                | Connector      | Terminal   |
| M107      | 103      | APP sensor                          | M153*1<br>M9*2 | 3*1<br>6*2 |
|           |          | EVAP control system pressure sensor | B73            | 3          |
|           | 107      | Refrigerant pressure sensor         | E77            | 3          |

\*1: With ICC

\*2: Without ICC

Is the inspection result normal?

YES >> GO TO 6.

NO >> Repair short to ground or short to power in harness or connectors.

## 6. CHECK COMPONENTS

Check the following.

- Crankshaft position sensor (POS) (Refer to [EC-314, "Component Inspection"](#).)
- Battery current sensor (Refer to [EC-437, "Component Inspection"](#).)
- EVAP control system pressure sensor (Refer to [EC-349, "Component Inspection"](#).)
- Refrigerant pressure sensor (Refer to [EC-530, "Diagnosis Procedure"](#).)

Is the inspection result normal?

YES >> GO TO 7.

NO >> Replace malfunctioning component.

## 7. CHECK APP SENSOR

Refer to [EC-487, "Component Inspection"](#).

Is the inspection result normal?

YES >> GO TO 13.

NO >> GO TO 8.

## 8. REPLACE ACCELERATOR PEDAL ASSEMBLY

1. Replace accelerator pedal assembly.
2. Go to [EC-487, "Special Repair Requirement"](#).

>> INSPECTION END

## 9. CHECK CMP SENSOR (PHASE) GROUND CIRCUIT FOR OPEN AND SHORT

1. Turn ignition switch OFF.
2. Disconnect ECM harness connector.
3. Check the continuity between CMP sensor (PHASE) harness connector and ECM harness connector.

| DTC   | CMP sensor (PHASE) |           |          | ECM       |          | Continuity |
|-------|--------------------|-----------|----------|-----------|----------|------------|
|       | Bank               | Connector | Terminal | Connector | Terminal |            |
| P0340 | 1                  | F5        | 2        | F102      | 96       | Existed    |
| P0345 | 2                  | F18       | 2        |           | 92       |            |

4. Also check harness for short to ground and short to power.

Is the inspection result normal?

YES >> GO TO 10.

NO >> Repair open circuit, short to ground or short to power in harness or connectors.

## 10. CHECK CMP SENSOR (PHASE) INPUT SIGNAL CIRCUIT FOR OPEN AND SHORT

1. Check the continuity between CMP sensor (PHASE) harness connector and ECM harness connector.

# P0340, P0345 CMP SENSOR (PHASE)

< DTC/CIRCUIT DIAGNOSIS >

[VQ37VHR FOR USA AND CANADA]

| DTC   | CMP sensor (PHASE) |           |          | ECM       |          | Continuity |
|-------|--------------------|-----------|----------|-----------|----------|------------|
|       | Bank               | Connector | Terminal | Connector | Terminal |            |
| P0340 | 1                  | F5        | 3        | F102      | 59       | Existed    |
| P0345 | 2                  | F18       | 3        |           | 63       |            |

2. Also check harness for short to ground and short to power.

Is the inspection result normal?

YES >> GO TO 11.

NO >> Repair open circuit, short to ground or short to power in harness or connectors.

## 11. CHECK CAMSHAFT POSITION SENSOR (PHASE)

Refer to [EC-319, "Component Inspection"](#).

Is the inspection result normal?

YES >> GO TO 12.

NO >> Replace malfunctioning camshaft position sensor (PHASE). Refer to [EM-52, "Exploded View"](#).

## 12. CHECK CAMSHAFT (INTAKE)

Check the following.

- Accumulation of debris to the signal plate of camshaft front end
- Chipping signal plate of camshaft front end

Is the inspection result normal?

YES >> GO TO 13.

NO >> Remove debris and clean the signal plate of camshaft front end or replace camshaft.

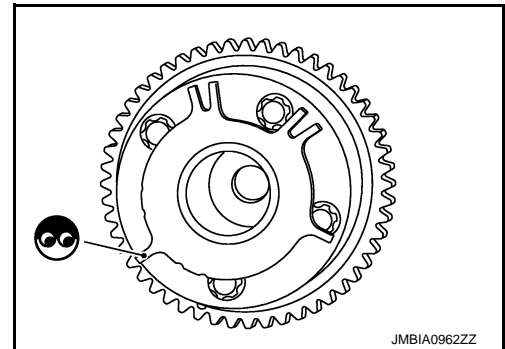

## 13. CHECK INTERMITTENT INCIDENT

Refer to [GI-44, "Intermittent Incident"](#).

>> INSPECTION END

## Component Inspection

INFOID:0000000006882967

### 1. CHECK CAMSHAFT POSITION SENSOR (PHASE)-I

1. Turn ignition switch OFF.
2. Loosen the fixing bolt of the sensor.
3. Disconnect camshaft position sensor (PHASE) harness connector.
4. Remove the sensor. Refer to [EM-52, "Exploded View"](#).
5. Visually check the sensor for chipping.

Is the inspection result normal?

YES >> GO TO 2.

NO >> Replace malfunctioning camshaft position sensor (PHASE). Refer to [EM-52, "Exploded View"](#).

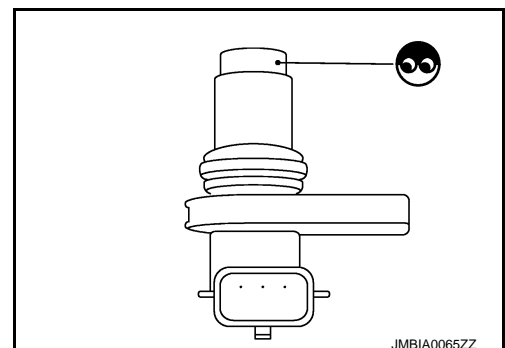

### 2. CHECK CAMSHAFT POSITION SENSOR (PHASE)-II

Check resistance camshaft position sensor (PHASE) terminals as follows.

## P0340, P0345 CMP SENSOR (PHASE)

< DTC/CIRCUIT DIAGNOSIS >

[VQ37VHR FOR USA AND CANADA]

| Terminals (Polarity) | Resistance ( $\Omega$ )               |
|----------------------|---------------------------------------|
| 1 (+) - 2 (-)        | Except 0 or $\infty$ [at 25°C (77°F)] |
| 1 (+) - 3 (-)        |                                       |
| 2 (+) - 3 (-)        |                                       |

Is the inspection result normal?

YES >> INSPECTION END

NO >> Replace malfunctioning camshaft position sensor (PHASE). Refer to [EM-52, "Exploded View"](#).



# P0420, P0430 THREE WAY CATALYST FUNCTION

< DTC/CIRCUIT DIAGNOSIS >

[VQ37VHR FOR USA AND CANADA]

## P0420, P0430 THREE WAY CATALYST FUNCTION

### DTC Logic

INFOID:000000006882968

#### DTC DETECTION LOGIC

The ECM monitors the switching frequency ratio of air fuel ratio (A/F) sensor 1 and heated oxygen sensor 2. A three way catalyst 1 with high oxygen storage capacity will indicate a low switching frequency of heated oxygen sensor 2. As oxygen storage capacity decreases, the heated oxygen sensor 2 switching frequency will increase.

When the frequency ratio of A/F sensor 1 and heated oxygen sensor 2 approaches a specified limit value, the three way catalyst 1 malfunction is diagnosed.

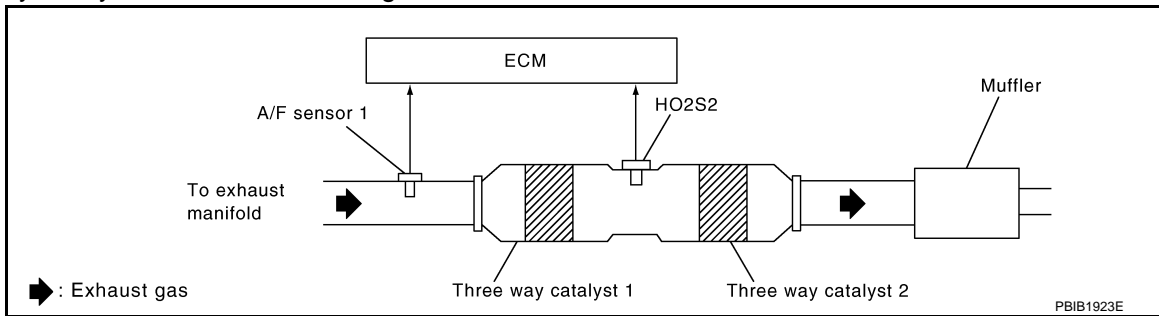

| DTC No. | Trouble diagnosis name                              | DTC detecting condition   | Possible cause  |
|---------|---|---|---|
| P0420   | Catalyst system efficiency below threshold (bank 1) | <ul style="list-style-type: none"> <li>Three way catalyst (manifold) does not operate properly.</li> <li>Three way catalyst (manifold) does not have enough oxygen storage capacity.</li> </ul> | <ul style="list-style-type: none"> <li>Three way catalyst (manifold)</li> <li>Exhaust tube</li> <li>Intake air leaks</li> <li>Fuel injector</li> <li>Fuel injector leaks</li> <li>Spark plug</li> <li>Improper ignition timing</li> </ul> |
| P0430   | Catalyst system efficiency below threshold (bank 2) |   |   |

#### DTC CONFIRMATION PROCEDURE

##### 1. INSPECTION START

Do you have CONSULT?

Do you have CONSULT?

YES >> GO TO 2.

NO >> GO TO 7.

##### 2. PRECONDITIONING

If DTC Confirmation Procedure has been previously conducted, always perform the following procedure before conducting the next test.

1. Turn ignition switch OFF and wait at least 10 seconds.
2. Turn ignition switch ON.
3. Turn ignition switch OFF and wait at least 10 seconds.

##### TESTING CONDITION:

Do not hold engine speed for more than the specified minutes below.

>> GO TO 3.

##### 3. PERFORM DTC CONFIRMATION PROCEDURE-I

###### Ⓜ With CONSULT

1. Turn ignition switch ON and select "DATA MONITOR" mode with CONSULT.
2. Start engine and warm it up to the normal operating temperature.
3. Turn ignition switch OFF and wait at least 10 seconds.
4. Turn ignition switch ON.
5. Turn ignition switch OFF and wait at least 10 seconds.
6. Start engine and keep the engine speed between 3,500 and 4,000 rpm for at least 1 minute under no load.
7. Let engine idle for 1 minute.

## P0420, P0430 THREE WAY CATALYST FUNCTION

[VQ37VHR FOR USA AND CANADA]

### < DTC/CIRCUIT DIAGNOSIS >

8. Make sure that "COOLAN TEMP/S" indicates more than 70°C (158°F).  
If not, warm up engine and go to next step when "COOLAN TEMP/S" indication reaches 70°C (158°F).
9. Open engine hood.
10. Select "DTC & SRT CONFIRMATION" then "SRT WORK SUPPORT" mode with CONSULT.
11. Rev engine up to about 2,000 rpm and hold it for 3 consecutive minutes then release the accelerator pedal completely.
12. Check the indication of "CATALYST".

Which is displayed on CONSULT screen?

- CMPLT >> GO TO 6.
- INCMP >> GO TO 4.

### 4.PERFORM DTC CONFIRMATION PROCEDURE-II

1. Wait 5 seconds at idle.
2. Rev engine up to about 2,000 rpm and maintain it until "INCMP" of "CATALYST" changes to "CMPLT" (It will take approximately 5 minutes).

Does the indication change to "CMPLT"?

- YES >> GO TO 6.
- NO >> GO TO 5.

### 5.PERFORM DTC CONFIRMATION PROCEDURE AGAIN

1. Stop engine and cool it down to less than 70°C (158°F).
2. Perform DTC CONFIRMATION PROCEDURE again.

>> GO TO 3.

### 6.PERFORM DTC CONFIRMATION PROCEDURE-III

Check 1st trip DTC.

Is 1st trip DTC detected?

- YES >> Go to [EC-323, "Diagnosis Procedure"](#).
- NO >> INSPECTION END

### 7.PERFORM COMPONENT FUNCTION CHECK

Perform component function check. Refer to [EC-322, "Component Function Check"](#).

#### NOTE:

Use component function check to check the overall function of the three way catalyst (manifold). During this check, a 1st trip DTC might not be confirmed.

Is the inspection result normal?

- YES >> INSPECTION END
- NO >> Go to [EC-323, "Diagnosis Procedure"](#).

### Component Function Check

INFOID:000000006882969

### 1.PERFORM COMPONENT FUNCTION CHECK

#### ⊗ Without CONSULT

1. Start engine and warm it up to the normal operating temperature.
2. Turn ignition switch OFF and wait at least 10 seconds.
3. Start engine and keep the engine speed between 3,500 and 4,000 rpm for at least 1 minute under no load.
4. Let engine idle for 1 minute.
5. Open engine hood.
6. Check the voltage between ECM harness connector terminals under the following condition.

# P0420, P0430 THREE WAY CATALYST FUNCTION

< DTC/CIRCUIT DIAGNOSIS >

[VQ37VHR FOR USA AND CANADA]

| DTC   | ECM       |                        |          | Condition  | Voltage  |
|-------|-----------|------------------------|----------|--|--|
|       | Connector | +                      | -        |  |  |
|       |           | Terminal               | Terminal |  |  |
| P0420 | F102      | 76<br>[HO2S2 (bank 1)] | 84       | Keeping engine speed at 2,500 rpm constant under no load | The voltage fluctuation cycle takes more than 5 seconds.<br>• 1 cycle: 0.6 - 1.0 → 0 - 0.3 → 0.6 - 1.0 |
| P0430 |           | 80<br>[HO2S2 (bank 2)] |          |  |  |

Is the inspection result normal?

YES >> INSPECTION END

NO >> Go to [EC-323, "Diagnosis Procedure"](#).

## Diagnosis Procedure

INFOID:000000006882970

### 1. CHECK EXHAUST SYSTEM

Visually check exhaust tubes and muffler for dents.

Is the inspection result normal?

YES >> GO TO 2.

NO >> Repair or replace.

### 2. CHECK EXHAUST GAS LEAK

1. Start engine and run it at idle.
2. Listen for an exhaust gas leak before the three way catalyst 1.

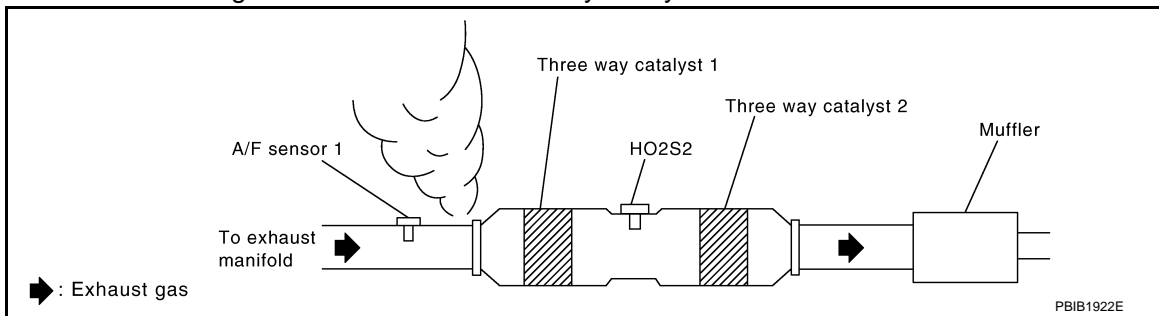

Is exhaust gas leak detected?

YES >> Repair or replace.

NO >> GO TO 3.

### 3. CHECK INTAKE AIR LEAK

Listen for an intake air leak after the mass air flow sensor.

Is intake air leak detected?

YES >> Repair or replace.

NO >> GO TO 4.

### 4. CHECK IDLE SPEED AND IGNITION TIMING

For procedure, refer to [EC-154, "Work Procedure"](#).

For specification, refer to [EC-545, "Idle Speed"](#) and [EC-545, "Ignition Timing"](#).

Is the inspection result normal?

YES >> GO TO 5.

NO >> Follow the [EC-154, "Work Procedure"](#).

### 5. CHECK FUEL INJECTORS

1. Stop engine and then turn ignition switch ON.
2. Check the voltage between ECM harness connector terminals as per the following.

# P0420, P0430 THREE WAY CATALYST FUNCTION

< DTC/CIRCUIT DIAGNOSIS >

[VQ37VHR FOR USA AND CANADA]

| ECM       |          |           |          | Voltage         |
|-----------|----------|-----------|----------|-----------------|
| +         |          | -         |          |                 |
| Connector | Terminal | Connector | Terminal |                 |
| F102      | 81       | M107      | 128      | Battery voltage |
|           | 82       |           |          |                 |
|           | 85       |           |          |                 |
|           | 86       |           |          |                 |
|           | 89       |           |          |                 |
|           | 90       |           |          |                 |

Is the inspection result normal?

YES >> GO TO 6.

NO >> Perform [EC-512, "Diagnosis Procedure"](#).

## 6. CHECK FUNCTION OF IGNITION COIL-I

### CAUTION:

Perform the following procedure in a place where with no combustible objects and good ventilation.

1. Turn ignition switch OFF.
2. Remove fuel pump fuse (1) in IPDM E/R (2) to release fuel pressure.

### NOTE:

Do not use CONSULT to release fuel pressure, or fuel pressure applies again during the following procedure.

3. Start engine.
4. After engine stalls, crank it two or three times to release all fuel pressure.
5. Turn ignition switch OFF.
6. Remove all ignition coil harness connectors to avoid the electrical discharge from the ignition coils.
7. Remove ignition coil and spark plug of the cylinder to be checked.
8. Crank engine for 5 seconds or more to remove combustion gas in the cylinder.
9. Connect spark plug and harness connector to ignition coil.
10. Fix ignition coil using a rope etc. with gap of 13 - 17 mm (0.52 - 0.66 in) between the edge of the spark plug and grounded metal portion as shown in the figure.
11. Crank engine for about 3 seconds, and check whether spark is generated between the spark plug and the grounded metal portion.

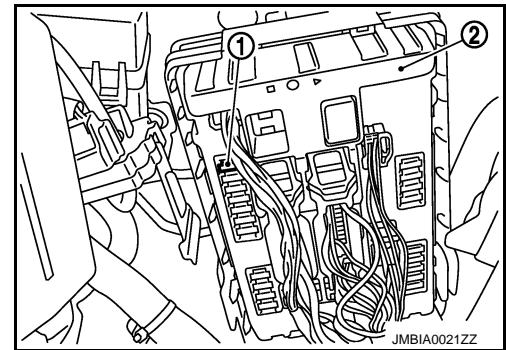

**Spark should be generated.**

### CAUTION:

- Never place the spark plug and the ignition coil within 50 cm (19.7 in) each other. Be careful not to get an electrical shock while checking, because the electrical discharge voltage becomes 20 kV or more.
- It might damage the ignition coil if the gap of more than 17 mm (0.66 in) is made.

### NOTE:

When the gap is less than 13 mm (0.52 in), a spark might be generated even if the coil is malfunctioning.

Is the inspection result normal?

YES >> GO TO 10.

NO >> GO TO 7.

## 7. CHECK FUNCTION OF IGNITION COIL-II

1. Turn ignition switch OFF.

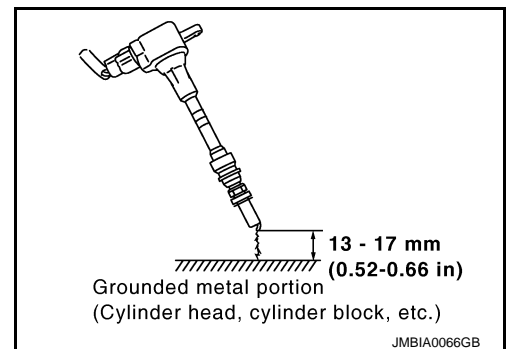

## P0420, P0430 THREE WAY CATALYST FUNCTION

[VQ37VHR FOR USA AND CANADA]

### < DTC/CIRCUIT DIAGNOSIS >

2. Disconnect spark plug and connect a non-malfunctioning spark plug.
3. Crank engine for about 3 seconds, and recheck whether spark is generated between the spark plug and the grounded metal portion.

**Spark should be generated.**

Is the inspection result normal?

YES >> GO TO 8.

NO >> Check ignition coil, power transistor and their circuits. Refer to [EC-519, "Diagnosis Procedure"](#).

### 8.CHECK SPARK PLUG

Check the initial spark plug for fouling, etc.

Is the inspection result normal?

YES >> Replace spark plug(s) with standard type one(s). For spark plug type, refer to [EM-26, "Inspection"](#).

NO >> Repair or clean spark plug. Then GO TO 9.

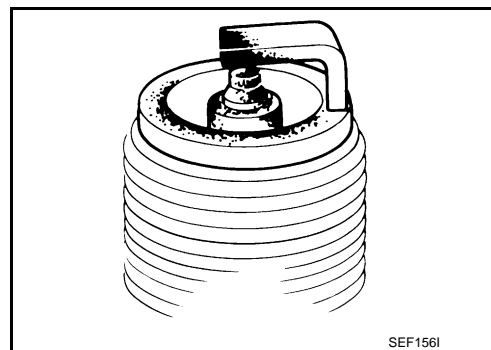

### 9.CHECK FUNCTION OF IGNITION COIL-III

1. Reconnect the initial spark plugs.
2. Crank engine for about three seconds, and recheck whether spark is generated between the spark plug and the grounded portion.

**Spark should be generated.**

Is the inspection result normal?

YES >> INSPECTION END

NO >> Replace spark plug(s) with standard type one(s). For spark plug type, refer to [EM-25, "Removal and Installation"](#).

### 10.CHECK FUEL INJECTOR

1. Turn ignition switch OFF.
2. Remove fuel injector assembly.  
Refer to [EM-39, "Removal and Installation"](#).  
Keep fuel hose and all fuel injectors connected to fuel tube.
3. Disconnect all ignition coil harness connectors.
4. Reconnect all fuel injector harness connectors disconnected.
5. Turn ignition switch ON.
6. Check that fuel does not drip from fuel injector.

Does fuel drip from fuel injector?

YES >> Replace the fuel injector(s) from which fuel is dripping.

NO >> GO TO 11.

### 11.CHECK INTERMITTENT INCIDENT

Refer to [GI-44, "Intermittent Incident"](#).

Is the inspection result normal?

YES >> Replace three way catalyst assembly. Refer to [EX-5, "VQ37VHR : Exploded View"](#).

NO >> Repair or replace harness or connector.

# P0441 EVAP CONTROL SYSTEM

< DTC/CIRCUIT DIAGNOSIS >

[VQ37VHR FOR USA AND CANADA]

## P0441 EVAP CONTROL SYSTEM

### DTC Logic

INFOID:000000006882971

#### DTC DETECTION LOGIC

**NOTE:**

If DTC P0441 is displayed with other DTC such as P2122, P2123, P2127, P2128 or P2138, first perform trouble diagnosis for other DTC.

In this evaporative emission (EVAP) control system, purge flow occurs during non-closed throttle conditions. Purge volume is related to air intake volume. Under normal purge conditions (non-closed throttle), the EVAP canister purge volume control solenoid valve is open to admit purge flow. Purge flow exposes the EVAP control system pressure sensor to intake manifold vacuum.

Under normal conditions (non-closed throttle), sensor output voltage indicates if pressure drop and purge flow are adequate. If not, a malfunction is determined.

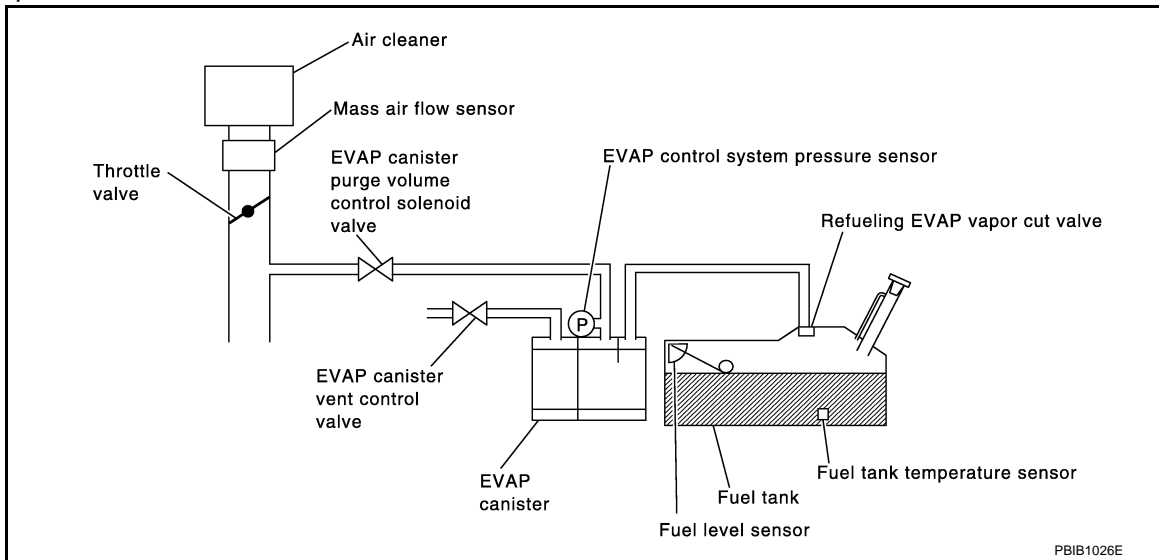

| DTC No. | Trouble diagnosis name                   | DTC detecting condition  | Possible cause   |
|---------|--|--|--|
| P0441   | EVAP control system incorrect purge flow | EVAP control system does not operate properly, EVAP control system has a leak between intake manifold and EVAP control system pressure sensor. | <ul style="list-style-type: none"> <li>• EVAP canister purge volume control solenoid valve stuck closed</li> <li>• EVAP control system pressure sensor and the circuit</li> <li>• Loose, disconnected or improper connection of rubber tube</li> <li>• Blocked rubber tube</li> <li>• Cracked EVAP canister</li> <li>• EVAP canister purge volume control solenoid valve circuit</li> <li>• Accelerator pedal position sensor</li> <li>• Blocked purge port</li> <li>• EVAP canister vent control valve</li> </ul> |

#### DTC CONFIRMATION PROCEDURE

##### 1.INSPECTION START

Do you have CONSULT?

Do you have CONSULT?

YES >> GO TO 2.

NO >> GO TO 6.

##### 2.PRECONDITIONING

If DTC Confirmation Procedure has been previously conducted, always perform the following procedure before conducting the next test.

1. Turn ignition switch OFF and wait at least 10 seconds.
2. Turn ignition switch ON.
3. Turn ignition switch OFF and wait at least 10 seconds.

**TESTING CONDITION:**

Always perform test at a temperature of 5°C (41°F) or more.

# P0441 EVAP CONTROL SYSTEM

< DTC/CIRCUIT DIAGNOSIS >

[VQ37VHR FOR USA AND CANADA]

>> GO TO 3.

## 3. PERFORM DTC CONFIRMATION PROCEDURE-I

### With CONSULT

1. Start engine and warm it up to normal operating temperature.
2. Turn ignition switch OFF and wait at least 10 seconds.
3. Turn ignition switch ON.
4. Turn ignition switch OFF and wait at least 10 seconds.
5. Start engine and let it idle for at least 70 seconds.
6. Select "PURG FLOW P0441" of "EVAPORATIVE SYSTEM" in "DTC WORK SUPPORT" mode with CONSULT.
7. Touch "START".

Is "COMPLETED" displayed on CONSULT screen?

YES >> GO TO 5.

NO >> GO TO 4.

## 4. PERFORM DTC CONFIRMATION PROCEDURE-II

When the following conditions are met, "TESTING" will be displayed on the CONSULT screen. Maintain the conditions continuously until "TESTING" changes to "COMPLETED". (It will take at least 35 seconds.)

| Selector lever | Suitable position           |
|----------------|-----------------------------|
| VHCL SPEED SE  | 32 - 120 km/h (20 - 75 mph) |
| ENG SPEED      | 500 - 3,000 rpm             |
| B/FUEL SCHDL   | 1.25 - 9.0 msec             |
| COOLAN TEMP/S  | More than 0°C (32°F)        |

### **CAUTION:**

**Always drive vehicle at a safe speed.**

Is "COMPLETED" displayed on CONSULT screen?

YES >> GO TO 5.

NO >> Perform DTC CONFIRMATION PROCEDURE again. GO TO 3.

## 5. PERFORM DTC CONFIRMATION PROCEDURE-III

Touch "SELF-DIAG RESULTS".

Which is displayed on CONSULT screen?

OK >> INSPECTION END

NG >> Go to [EC-328, "Diagnosis Procedure"](#).

## 6. PERFORM COMPONENT FUNCTION CHECK

Perform component function check. Refer to [EC-327, "Component Function Check"](#).

### **NOTE:**

Use component function check to check the overall monitoring function of the EVAP control system purge flow monitoring. During this check, a 1st trip DTC might not be confirmed.

Is the inspection result normal?

YES >> INSPECTION END

NO >> Go to [EC-328, "Diagnosis Procedure"](#).

## Component Function Check

INFOID:000000006882972

## 1. PERFORM COMPONENT FUNCTION CHECK

### Without CONSULT

1. Lift up drive wheels.
2. Start engine (VDC switch OFF) and warm it up to normal operating temperature.
3. Turn ignition switch OFF and wait at least 10 seconds.
4. Turn ignition switch ON.
5. Turn ignition switch OFF and wait at least 10 seconds.

# P0441 EVAP CONTROL SYSTEM

[VQ37VHR FOR USA AND CANADA]

## < DTC/CIRCUIT DIAGNOSIS >

6. Start engine and wait at least 70 seconds.
7. Set voltmeter probes to ECM harness connector terminals as per the following.

| ECM       |   |          |
|-----------|---|----------|
| Connector | +   | -        |
|           | Terminal  | Terminal |
| M107      | 102<br>(EVAP control system pressure sensor signal) | 112      |

8. Check EVAP control system pressure sensor value at idle speed and note it.
9. Establish and maintain the following conditions for at least 1 minute.

|                             |                                   |
|-----------------------------|-----------------------------------|
| Air conditioner switch      | ON                                |
| Headlamp switch             | ON                                |
| Rear window defogger switch | ON                                |
| Engine speed                | Approx. 3,000 rpm                 |
| Gear position               | Any position other than P, N or R |

10. Verify that EVAP control system pressure sensor value stays 0.1 V less than the value at idle speed (measured at step 8) for at least 1 second.

### Is the inspection result normal?

- YES >> INSPECTION END  
NO >> Go to [EC-328, "Diagnosis Procedure"](#).

## Diagnosis Procedure

INFOID:000000006882973

### 1.CHECK EVAP CANISTER

1. Turn ignition switch OFF.
2. Check EVAP canister for cracks.

### Is the inspection result normal?

- YES-1 >> With CONSULT: GO TO 2.  
YES-2 >> Without CONSULT: GO TO 3.  
NO >> Replace EVAP canister. Refer to [FL-13, "Exploded View"](#).

### 2.CHECK PURGE FLOW

#### With CONSULT

1. Disconnect vacuum hose connected to EVAP canister purge volume control solenoid valve at EVAP service port.
2. Start engine and let it idle.
3. Select "PURG VOL CONT/V" in "ACTIVE TEST" mode with CONSULT.
4. Touch "Qd" and "Qu" on CONSULT screen to adjust "PURG VOL C/V" opening and check vacuum existence.

|              |             |
|--------------|-------------|
| PURG VOL C/V | Vacuum      |
| 100%         | Existed     |
| 0%           | Not existed |

### Is the inspection result normal?

- YES >> GO TO 7.  
NO >> GO TO 4.

### 3.CHECK PURGE FLOW

#### Without CONSULT

1. Start engine and warm it up to normal operating temperature.
2. Stop engine.



# P0441 EVAP CONTROL SYSTEM

[VQ37VHR FOR USA AND CANADA]

## < DTC/CIRCUIT DIAGNOSIS >

3. Disconnect vacuum hose connected to EVAP canister purge volume control solenoid valve at EVAP service port and install vacuum gauge. For the location of EVAP service port, refer to [EC-65, "EVAPORATIVE EMISSION SYSTEM : System Diagram"](#).
4. Start engine and let it idle.  
**Do not depress accelerator pedal even slightly.**
5. Check vacuum gauge indication before 60 seconds passed after starting engine.

**Vacuum should not exist.**

6. Revving engine up to 2,000rpm after 100 seconds passed after starting engine.

**Vacuum should exist.**

Is the inspection result normal?

- YES >> GO TO 7.
- NO >> GO TO 4.

## 4.CHECK EVAP PURGE LINE

1. Turn ignition switch OFF.
2. Check EVAP purge line for improper connection or disconnection.  
Refer to [EC-65, "EVAPORATIVE EMISSION SYSTEM : System Diagram"](#).

Is the inspection result normal?

- YES >> GO TO 5.
- NO >> Repair it.

## 5.CHECK EVAP PURGE HOSE AND PURGE PORT

1. Disconnect purge hoses connected to EVAP service port **A** and EVAP canister purge volume control solenoid valve **B**.
2. Blow air into each hose and EVAP purge port **C**.

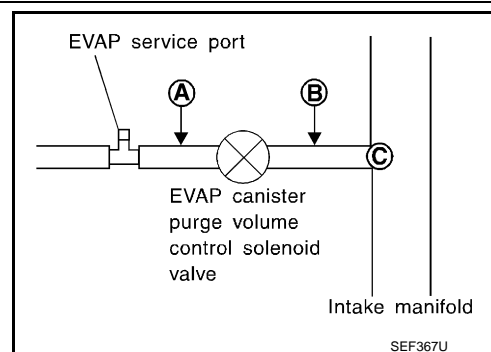

3. Check that air flows freely.

Is the inspection result normal?

- YES-1 >> With CONSULT: GO TO 6.
- YES-2 >> Without CONSULT: GO TO 7.
- NO >> Repair or clean hoses and/or purge port.

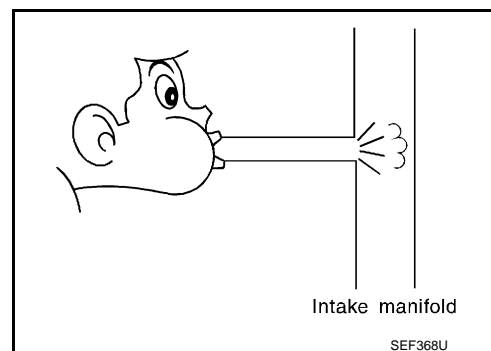

## 6.CHECK EVAP CANISTER PURGE VOLUME CONTROL SOLENOID VALVE

**With CONSULT**

1. Start engine.
2. Perform "PURG VOL CONT/V" in "ACTIVE TEST" mode with CONSULT. Check that engine speed varies according to the valve opening.

Does engine speed vary according to the valve opening?

- YES >> GO TO 8.
- NO >> GO TO 7.

## P0441 EVAP CONTROL SYSTEM

< DTC/CIRCUIT DIAGNOSIS >

[VQ37VHR FOR USA AND CANADA]

---

### 7. CHECK EVAP CANISTER PURGE VOLUME CONTROL SOLENOID VALVE

---

Refer to [EC-334, "Component Inspection"](#).

Is the inspection result normal?

YES >> GO TO 8.

NO >> Replace EVAP canister purge volume control solenoid valve. Refer to [EM-31, "Exploded View"](#).

---

### 8. CHECK EVAP CONTROL SYSTEM PRESSURE SENSOR CONNECTOR

---

1. Disconnect EVAP control system pressure sensor harness connector.
2. Check connectors for water.

**Water should not exist.**

Is the inspection result normal?

YES >> GO TO 9.

NO >> Replace EVAP control system pressure sensor. Refer to [FL-13, "Exploded View"](#).

---

### 9. CHECK EVAP CONTROL SYSTEM PRESSURE SENSOR FUNCTION

---

Refer to [EC-350, "DTC Logic"](#) for DTC P0452, [EC-355, "DTC Logic"](#) for DTC P0453.

Is the inspection result normal?

YES >> GO TO 10.

NO >> Replace EVAP control system pressure sensor.

---

### 10. CHECK RUBBER TUBE FOR CLOGGING

---

1. Disconnect rubber tube connected to EVAP canister vent control valve.
2. Check the rubber tube for clogging.

Is the inspection result normal?

YES >> GO TO 11.

NO >> Clean the rubber tube using an air blower.

---

### 11. CHECK EVAP CANISTER VENT CONTROL VALVE

---

Refer to [EC-340, "Component Inspection"](#).

Is the inspection result normal?

YES >> GO TO 12.

NO >> Replace EVAP canister vent control valve. Refer to [FL-13, "Exploded View"](#).

---

### 12. CHECK EVAP PURGE LINE

---

Inspect EVAP purge line (pipe and rubber tube). Check for evidence of leaks.

Refer to [EC-65, "EVAPORATIVE EMISSION SYSTEM : System Diagram"](#).

Is the inspection result normal?

YES >> GO TO 13.

NO >> Replace it.

---

### 13. CLEAN EVAP PURGE LINE

---

Clean EVAP purge line (pipe and rubber tube) using air blower.

>> GO TO 14.

---

### 14. CHECK INTERMITTENT INCIDENT

---

Refer to [GI-44, "Intermittent Incident"](#).

>> INSPECTION END

# P0443 EVAP CANISTER PURGE VOLUME CONTROL SOLENOID VALVE

< DTC/CIRCUIT DIAGNOSIS >

[VQ37VHR FOR USA AND CANADA]

## P0443 EVAP CANISTER PURGE VOLUME CONTROL SOLENOID VALVE

### DTC Logic

INFOID:000000006882974

### DTC DETECTION LOGIC

| DTC No. | Trouble diagnosis name                            | DTC detecting condition  | Possible cause  |
|---------|---|--|---|
| P0443   | EVAP canister purge volume control solenoid valve | The canister purge flow is detected during the specified driving conditions, even when EVAP canister purge volume control solenoid valve is completely closed. | <ul style="list-style-type: none"><li>• EVAP control system pressure sensor</li><li>• EVAP canister purge volume control solenoid valve (The valve is stuck open.)</li><li>• EVAP canister vent control valve</li><li>• EVAP canister</li><li>• Hoses (Hoses are connected incorrectly or clogged.)</li></ul> |

### DTC CONFIRMATION PROCEDURE

#### 1. PRECONDITIONING

If DTC Confirmation Procedure has been previously conducted, always perform the following procedure before conducting the next test.

1. Turn ignition switch OFF and wait at least 10 seconds.
2. Turn ignition switch ON.
3. Turn ignition switch OFF and wait at least 10 seconds.

#### TESTING CONDITION:

**Always perform test at a temperature of 5°C (41°F) or more.**

Do you have CONSULT

- YES >> GO TO 2.  
NO >> GO TO 3.

#### 2. PERFORM DTC CONFIRMATION PROCEDURE

##### With CONSULT

1. Start engine and warm it up to normal operating temperature.
2. Turn ignition switch OFF and wait at least 10 seconds.
3. Turn ignition switch ON.
4. Turn ignition switch OFF and wait at least 10 seconds.
5. Turn ignition switch ON.
6. Select "PURG VOL CN/V P1444" of "EVAPORATIVE SYSTEM" in "DTC WORK SUPPORT" mode with CONSULT.
7. Touch "START".
8. Start engine and let it idle until "TESTING" on CONSULT changes to "COMPLETED". (It will take approximately 10 seconds.)  
**If "TESTING" is not displayed after 5 minutes, retry from step 2.**
9. Touch "SELF-DIAG RESULTS".

Which is displayed on CONSULT screen?

- OK >> INSPECTION END  
NG >> Go to [EC-332. "Diagnosis Procedure"](#).

#### 3. PERFORM DTC CONFIRMATION PROCEDURE

##### With GST

1. Start engine and warm it up to normal operating temperature.
2. Turn ignition switch OFF and wait at least 10 seconds.
3. Turn ignition switch ON.
4. Turn ignition switch OFF and wait at least 10 seconds.
5. Start engine and let it idle for at least 20 seconds.
6. Check 1st trip DTC.

Is 1st trip DTC displayed?

- YES >> Go to [EC-332. "Diagnosis Procedure"](#).  
NO >> INSPECTION END

# P0443 EVAP CANISTER PURGE VOLUME CONTROL SOLENOID VALVE

< DTC/CIRCUIT DIAGNOSIS >

[VQ37VHR FOR USA AND CANADA]

INFOID:00000006882975

## Diagnosis Procedure

### 1. CHECK EVAP CANISTER PURGE VOLUME CONTROL SOLENOID VALVE POWER SUPPLY CIRCUIT

1. Turn ignition switch OFF.
2. Disconnect EVAP canister purge volume control solenoid valve harness connector.
3. Turn ignition switch ON.
4. Check the voltage between EVAP canister purge volume control solenoid valve harness connector and ground.

| EVAP canister purge volume control solenoid valve |          | Ground | Voltage         |
|---|----------|--------|-----------------|
| Connector   | Terminal |        |                 |
| F7  | 1        | Ground | Battery voltage |

Is the inspection result normal?

YES >> GO TO 3.

NO >> GO TO 2.

### 2. DETECT MALFUNCTIONING PART

Check the following.

- Harness connectors E106, M6
- Harness connectors M116, F103
- Harness for open or short between EVAP canister purge volume control solenoid valve and IPDM E/R
- Harness for open or short between EVAP canister purge volume control solenoid valve and ECM

>> Repair open circuit, short to ground or short to power in harness or connectors.

### 3. CHECK EVAP CANISTER PURGE VOLUME CONTROL SOLENOID VALVE OUTPUT SIGNAL CIRCUIT FOR OPEN AND SHORT

1. Turn ignition switch OFF.
2. Disconnect ECM harness connector.
3. Check the continuity between EVAP canister purge volume control solenoid valve harness connector and ECM harness connector.

| EVAP canister purge volume control solenoid valve |          | ECM       |          | Continuity |
|---|----------|-----------|----------|------------|
| Connector   | Terminal | Connector | Terminal |            |
| F7  | 2        | F101      | 21       | Existed    |

4. Also check harness for short to ground and short to power.

Is the inspection result normal?

YES >> GO TO 4.

NO >> Repair open circuit, short to ground or short to power in harness or connectors.

### 4. CHECK EVAP CONTROL SYSTEM PRESSURE SENSOR CONNECTOR

1. Disconnect EVAP control system pressure sensor harness connector.
2. Check connectors for water.

**Water should not exist.**

Is the inspection result normal?

YES >> GO TO 5.

NO >> Replace EVAP control system pressure sensor. Refer to [FL-13, "Exploded View"](#).

### 5. CHECK EVAP CONTROL SYSTEM PRESSURE SENSOR

Refer to [EC-349, "Component Inspection"](#).

Is the inspection result normal?

YES-1 >> With CONSULT: GO TO 6.

# P0443 EVAP CANISTER PURGE VOLUME CONTROL SOLENOID VALVE

< DTC/CIRCUIT DIAGNOSIS >

[VQ37VHR FOR USA AND CANADA]

YES-2 >> Without CONSULT: GO TO 7.

NO >> Replace EVAP control system pressure sensor. Refer to [FL-13, "Exploded View"](#).

## 6. CHECK EVAP CANISTER PURGE VOLUME CONTROL SOLENOID VALVE

### With CONSULT

1. Turn ignition switch OFF.
2. Reconnect harness connectors disconnected.
3. Start engine.
4. Perform "PURG VOL CONT/V" in "ACTIVE TEST" mode with CONSULT. Check that engine speed varies according to the valve opening.

Does engine speed vary according to the valve opening?

YES >> GO TO 8.

NO >> GO TO 7.

## 7. CHECK EVAP CANISTER PURGE VOLUME CONTROL SOLENOID VALVE

Refer to [EC-334, "Component Inspection"](#).

Is the inspection result normal?

YES >> GO TO 8.

NO >> Replace EVAP canister purge volume control solenoid valve. Refer to [EM-31, "Exploded View"](#).

## 8. CHECK RUBBER TUBE FOR CLOGGING

1. Disconnect rubber tube connected to EVAP canister vent control valve.
2. Check the rubber tube for clogging.

Is the inspection result normal?

YES >> GO TO 9.

NO >> Clean the rubber tube using an air blower.

## 9. CHECK EVAP CANISTER VENT CONTROL VALVE

Refer to [EC-340, "Component Inspection"](#).

Is the inspection result normal?

YES >> GO TO 10.

NO >> Replace EVAP canister vent control valve. Refer to [FL-13, "Exploded View"](#).

## 10. CHECK IF EVAP CANISTER IS SATURATED WITH WATER

1. Remove EVAP canister with EVAP canister vent control valve and EVAP control system pressure sensor attached.
2. Check if water will drain from EVAP canister (1).

2 : EVAP canister vent control valve

Does water drain from the EVAP canister?

YES >> GO TO 11.

NO >> GO TO 13.

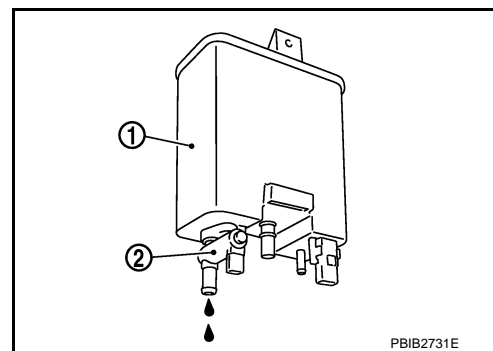

## 11. CHECK EVAP CANISTER

Weigh the EVAP canister with the EVAP canister vent control valve and EVAP control system pressure sensor attached.

**The weight should be less than 2.1 kg (4.6 lb).**

Is the inspection result normal?

YES >> GO TO 13.

NO >> GO TO 12.

## 12. DETECT MALFUNCTIONING PART

Check the following.

# P0443 EVAP CANISTER PURGE VOLUME CONTROL SOLENOID VALVE

< DTC/CIRCUIT DIAGNOSIS >

[VQ37VHR FOR USA AND CANADA]

- EVAP canister for damage
- EVAP hose between EVAP canister and vehicle frame for clogging or poor connection

>> Repair hose or replace EVAP canister.

## 13. CHECK INTERMITTENT INCIDENT

Refer to [GI-44, "Intermittent Incident"](#).

>> INSPECTION END

## Component Inspection

INFOID:000000006882976

### 1. CHECK EVAP CANISTER PURGE VOLUME CONTROL SOLENOID VALVE

#### With CONSULT

1. Turn ignition switch OFF.
2. Reconnect all harness connectors disconnected.
3. Disconnect EVAP purge hoses connected to EVAP canister purge volume control solenoid valve.
4. Turn ignition switch ON.
5. Select "PURG VOL CONT/V" in "ACTIVE TEST" mode with CONSULT.
6. Touch "Qd" and "Qu" on CONSULT screen to adjust "PURG VOL C/V" opening and check air passage continuity of EVAP canister purge volume control solenoid valve under the following conditions.

| Condition<br>(PURG VOL C/V value) | Air passage continuity<br>between (A) and (B) |
|-----------------------------------|---|
| 100%                              | Existed                                       |
| 0%                                | Not existed                                   |

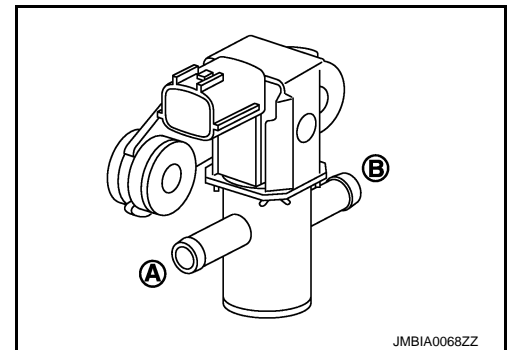

#### Without CONSULT

1. Turn ignition switch OFF.
2. Disconnect EVAP canister purge volume control solenoid valve harness connector.
3. Disconnect EVAP purge hoses connected to EVAP canister purge volume control solenoid valve.
4. Check air passage continuity of EVAP canister purge volume control solenoid valve under the following conditions.

| Condition  | Air passage continuity<br>between (A) and (B) |
|--|---|
| 12V direct current supply between<br>terminals 1 and 2 | Existed                                       |
| No supply  | Not existed                                   |

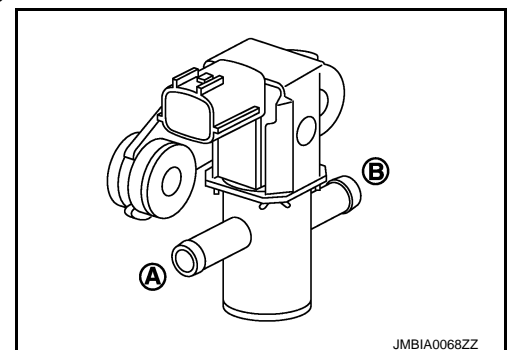

Is the inspection result normal?

YES >> INSPECTION END

NO >> Replace EVAP canister purge volume control solenoid valve. Refer to [EM-31, "Exploded View"](#).

# P0444, P0445 EVAP CANISTER PURGE VOLUME CONTROL SOLENOID VALVE

< DTC/CIRCUIT DIAGNOSIS >

[VQ37VHR FOR USA AND CANADA]

## P0444, P0445 EVAP CANISTER PURGE VOLUME CONTROL SOLENOID VALVE

### DTC Logic

INFOID:000000006882977

### DTC DETECTION LOGIC

| DTC No. | Trouble diagnosis name  | DTC detecting condition   | Possible cause  |
|---------|---|---|---|
| P0444   | EVAP canister purge volume control solenoid valve circuit open    | An excessively low voltage signal is sent to ECM through the valve  | <ul style="list-style-type: none"> <li>Harness or connectors (The solenoid valve circuit is open or shorted.)</li> <li>EVAP canister purge volume control solenoid valve</li> </ul> |
| P0445   | EVAP canister purge volume control solenoid valve circuit shorted | An excessively high voltage signal is sent to ECM through the valve | <ul style="list-style-type: none"> <li>Harness or connectors (The solenoid valve circuit is shorted.)</li> <li>EVAP canister purge volume control solenoid valve</li> </ul>         |

### DTC CONFIRMATION PROCEDURE

#### 1.CONDITIONING

If DTC Confirmation Procedure has been previously conducted, always perform the following procedure before conducting the next test.

1. Turn ignition switch OFF and wait at least 10 seconds.
2. Turn ignition switch ON.
3. Turn ignition switch OFF and wait at least 10 seconds.

#### TESTING CONDITION:

Before performing the following procedure, confirm battery voltage is more than 11 V at idle.

>> GO TO 2.

#### 2.PERFORM DTC CONFIRMATION PROCEDURE

1. Start engine and let it idle for at least 13 seconds.
2. Check 1st trip DTC.

Is 1st trip DTC detected?

- YES >> Go to [EC-335. "Diagnosis Procedure"](#).  
 NO >> INSPECTION END

### Diagnosis Procedure

INFOID:000000006882978

#### 1.CHECK EVAP CANISTER PURGE VOLUME CONTROL SOLENOID VALVE POWER SUPPLY CIRCUIT

1. Turn ignition switch OFF.
2. Disconnect EVAP canister purge volume control solenoid valve harness connector.
3. Turn ignition switch ON.
4. Check the voltage between EVAP canister purge volume control solenoid valve harness connector and ground.

| EVAP canister purge volume control solenoid valve |          | Ground | Voltage         |
|---|----------|--------|-----------------|
| Connector   | Terminal |        |                 |
| F7  | 1        | Ground | Battery voltage |

Is the inspection result normal?

- YES >> GO TO 3.  
 NO >> GO TO 2.

#### 2.DETECT MALFUNCTIONING PART

Check the following.

- Harness connectors E106, M6
- Harness connectors M116, F103
- Harness for open or short between EVAP canister purge volume control solenoid valve and IPDM E/R

# P0444, P0445 EVAP CANISTER PURGE VOLUME CONTROL SOLENOID VALVE

< DTC/CIRCUIT DIAGNOSIS >

[VQ37VHR FOR USA AND CANADA]

- Harness for open or short between EVAP canister purge volume control solenoid valve and ECM

>> Repair open circuit, short to ground or short to power in harness or connectors.

## 3. CHECK EVAP CANISTER PURGE VOLUME CONTROL SOLENOID VALVE OUTPUT SIGNAL CIRCUIT FOR OPEN AND SHORT

1. Turn ignition switch OFF.
2. Disconnect ECM harness connector.
3. Check the continuity between EVAP canister purge volume control solenoid valve harness connector and ECM harness connector.

| EVAP canister purge volume control solenoid valve |          | ECM       |          | Continuity |
|---|----------|-----------|----------|------------|
| Connector   | Terminal | Connector | Terminal |            |
| F7  | 2        | F101      | 21       | Existed    |

4. Also check harness for short to ground and short to power.

Is the inspection result normal?

YES-1 >> With CONSULT: GO TO 4.

YES-2 >> Without CONSULT: GO TO 5.

NO >> Repair open circuit, short to ground or short to power in harness or connectors.

## 4. CHECK EVAP CANISTER PURGE VOLUME CONTROL SOLENOID VALVE OPERATION

**Ⓟ With CONSULT**

1. Reconnect all harness connectors disconnected.
2. Start engine.
3. Perform "PURG VOL CONT/V" in "ACTIVE TEST" mode with CONSULT. Check that engine speed varies according to the valve opening.

Does engine speed vary according to the valve opening?

YES >> GO TO 6.

NO >> GO TO 5.

## 5. CHECK EVAP CANISTER PURGE VOLUME CONTROL SOLENOID VALVE

Refer to [EC-336, "Component Inspection"](#).

Is the inspection result normal?

YES >> GO TO 6.

NO >> Replace EVAP canister purge volume control solenoid valve. Refer to [EM-31, "Exploded View"](#).

## 6. CHECK INTERMITTENT INCIDENT

Refer to [GI-44, "Intermittent Incident"](#).

>> INSPECTION END

## Component Inspection

INFOID:000000006882979

## 1. CHECK EVAP CANISTER PURGE VOLUME CONTROL SOLENOID VALVE

**Ⓟ With CONSULT**

1. Turn ignition switch OFF.
2. Reconnect all harness connectors disconnected.
3. Disconnect EVAP purge hoses connected to EVAP canister purge volume control solenoid valve.
4. Turn ignition switch ON.
5. Select "PURG VOL CONT/V" in "ACTIVE TEST" mode with CONSULT.



# P0444, P0445 EVAP CANISTER PURGE VOLUME CONTROL SOLENOID VALVE

< DTC/CIRCUIT DIAGNOSIS >

[VQ37VHR FOR USA AND CANADA]

6. Touch "Qd" and "Qu" on CONSULT screen to adjust "PURG VOL C/V" opening and check air passage continuity of EVAP canister purge volume control solenoid valve under the following conditions.

| Condition<br>(PURG VOL C/V value) | Air passage continuity<br>between (A) and (B) |
|-----------------------------------|---|
| 100%                              | Existed                                       |
| 0%                                | Not existed                                   |

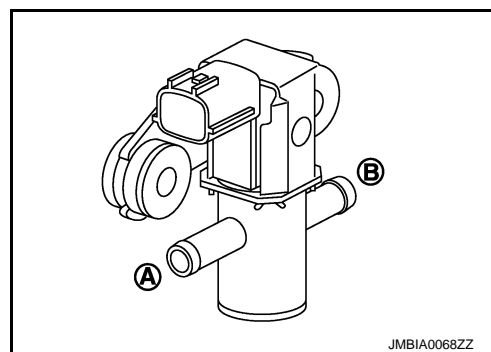

**⊗ Without CONSULT**

1. Turn ignition switch OFF.
2. Disconnect EVAP canister purge volume control solenoid valve harness connector.
3. Disconnect EVAP purge hoses connected to EVAP canister purge volume control solenoid valve.
4. Check air passage continuity of EVAP canister purge volume control solenoid valve under the following conditions.

| Condition   | Air passage continuity<br>between (A) and (B) |
|---|---|
| 12 V direct current supply between<br>terminals 1 and 2 | Existed                                       |
| No supply   | Not existed                                   |

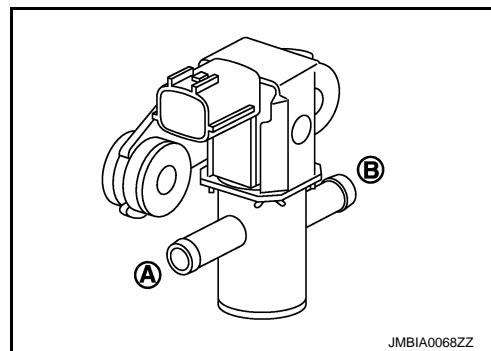

Is the inspection result normal?

YES >> INSPECTION END

NO >> Replace EVAP canister purge volume control solenoid valve. Refer to [EM-31, "Exploded View"](#).

A  
EC  
C  
D  
E  
F  
G  
H  
I  
J  
K  
L  
M  
N  
O  
P

# P0447 EVAP CANISTER VENT CONTROL VALVE

< DTC/CIRCUIT DIAGNOSIS >

[VQ37VHR FOR USA AND CANADA]

## P0447 EVAP CANISTER VENT CONTROL VALVE

### DTC Logic

INFOID:000000006882980

### DTC DETECTION LOGIC

| DTC No. | Trouble diagnosis name                        | DTC detecting condition   | Possible cause   |
|---------|---|---|--|
| P0447   | EVAP canister vent control valve circuit open | An improper voltage signal is sent to ECM through EVAP canister vent control valve. | <ul style="list-style-type: none"><li>• Harness or connectors (The valve circuit is open or shorted.)</li><li>• EVAP canister vent control valve</li></ul> |

### DTC CONFIRMATION PROCEDURE

#### 1. PRECONDITIONING

If DTC Confirmation Procedure has been previously conducted, always perform the following procedure before conducting the next test.

1. Turn ignition switch OFF and wait at least 10 seconds.
2. Turn ignition switch ON.
3. Turn ignition switch OFF and wait at least 10 seconds.

#### TESTING CONDITION:

Before performing the following procedure, confirm battery voltage is more than 11 V at idle.

>> GO TO 2.

#### 2. PERFORM DTC CONFIRMATION PROCEDURE

1. Start engine and wait at least 8 seconds.
2. Check 1st trip DTC.

Is 1st trip DTC detected?

- YES >> Go to [EC-338, "Diagnosis Procedure"](#).  
NO >> INSPECTION END

### Diagnosis Procedure

INFOID:000000006882981

#### 1. INSPECTION START

Do you have CONSULT?

Do you have CONSULT?

- YES >> GO TO 2.  
NO >> GO TO 3.

#### 2. CHECK EVAP CANISTER VENT CONTROL VALVE CIRCUIT

##### With CONSULT

1. Turn ignition switch OFF and then ON.
2. Select "VENT CONTROL/V" in "ACTIVE TEST" mode with CONSULT.
3. Touch "ON/OFF" on CONSULT screen.
4. Check for operating sound of the valve.

**Clicking sound should be heard.**

Is the inspection result normal?

- YES >> GO TO 7.  
NO >> GO TO 3.

#### 3. CHECK EVAP CANISTER VENT CONTROL VALVE POWER SUPPLY CIRCUIT

1. Turn ignition switch OFF.
2. Disconnect EVAP canister vent control valve harness connector.
3. Turn ignition switch ON.
4. Check the voltage between EVAP canister vent control valve harness connector and ground.

# P0447 EVAP CANISTER VENT CONTROL VALVE

< DTC/CIRCUIT DIAGNOSIS >

[VQ37VHR FOR USA AND CANADA]

| EVAP canister vent control valve |          | Ground | Voltage         |
|----------------------------------|----------|--------|-----------------|
| Connector                        | Terminal |        |                 |
| B74                              | 1        | Ground | Battery voltage |

Is the inspection result normal?

YES >> GO TO 5.

NO >> GO TO 4.

## 4. DETECT MALFUNCTIONING PART

Check the following.

- Harness connectors B8, E115
- Harness connectors B71, B72
- Harness for open or short between EVAP canister vent control valve and IPDM E/R

>> Repair open circuit, short to ground or short to power in harness or connectors.

## 5. CHECK EVAP CANISTER VENT CONTROL VALVE OUTPUT SIGNAL CIRCUIT FOR OPEN AND SHORT

1. Turn ignition switch OFF.
2. Disconnect ECM harness connector.
3. Check the continuity between EVAP canister vent control valve harness connector and ECM harness connector.

| EVAP canister vent control valve |          | ECM       |          | Continuity |
|----------------------------------|----------|-----------|----------|------------|
| Connector                        | Terminal | Connector | Terminal |            |
| B74                              | 2        | M107      | 121      | Existed    |

4. Also check harness for short to ground and short to power.

Is the inspection result normal?

YES >> GO TO 7.

NO >> GO TO 6.

## 6. DETECT MALFUNCTIONING PART

Check the following.

- Harness connectors B1, M7
- Harness connectors B71, B72
- Harness for open or short between EVAP canister vent control valve and ECM

>> Repair open circuit, short to ground or short to power in harness or connectors.

## 7. CHECK RUBBER TUBE FOR CLOGGING

1. Disconnect rubber tube connected to EVAP canister vent control valve.
2. Check the rubber tube for clogging.

Is the inspection result normal?

YES >> GO TO 8.

NO >> Clean the rubber tube using an air blower.

## 8. CHECK EVAP CANISTER VENT CONTROL VALVE

Refer to [EC-340, "Component Inspection"](#).

Is the inspection result normal?

YES >> GO TO 9.

NO >> Replace EVAP canister vent control valve. Refer to [FL-13, "Exploded View"](#).

## 9. CHECK INTERMITTENT INCIDENT

Refer to [GI-44, "Intermittent Incident"](#).

>> INSPECTION END

# P0447 EVAP CANISTER VENT CONTROL VALVE

[VQ37VHR FOR USA AND CANADA]

< DTC/CIRCUIT DIAGNOSIS >

INFOID:00000006882982

## Component Inspection

### 1. CHECK EVAP CANISTER VENT CONTROL VALVE-I

1. Turn ignition switch OFF.
2. Remove EVAP canister vent control valve from EVAP canister. Refer to [FL-13, "Exploded View"](#).
3. Check portion (A) of EVAP canister vent control valve for rust.

Is it rusted?

- YES >> Replace EVAP canister vent control valve. Refer to [FL-13, "Exploded View"](#).
- NO >> GO TO 2.

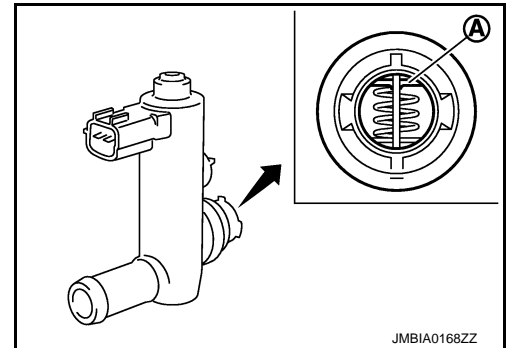

### 2. CHECK EVAP CANISTER VENT CONTROL VALVE-II

#### Ⓟ With CONSULT

1. Reconnect harness connectors disconnected.
2. Turn ignition switch ON.
3. Perform "VENT CONTROL/V" in "ACTIVE TEST" mode.
4. Check air passage continuity and operation delay time.  
**Make sure that new O-ring is installed properly.**

| Condition VENT CONT/V | Air passage continuity between (A) and (B) |
|-----------------------|--|
| ON                    | Not existed                                |
| OFF                   | Existed                                    |

**Operation takes less than 1 second.**

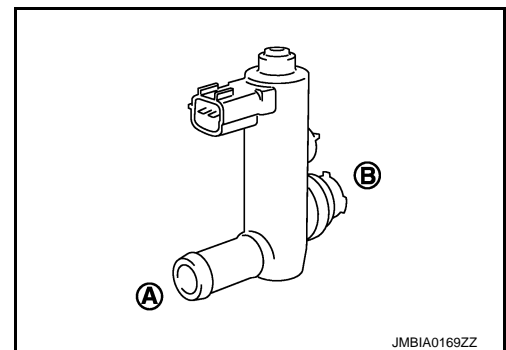

#### ⓧ Without CONSULT

1. Disconnect EVAP canister vent control valve harness connector.
2. Check air passage continuity and operation delay time under the following conditions.  
**Make sure that new O-ring is installed properly.**

| Condition  | Air passage continuity between (A) and (B) |
|--|--|
| 12 V direct current supply between terminals 1 and 2 | Not existed                                |
| OFF  | Existed                                    |

**Operation takes less than 1 second.**

Is the inspection result normal?

- YES >> GO TO 3.
- NO >> Replace EVAP canister vent control valve. Refer to [FL-13, "Exploded View"](#).

### 3. CHECK EVAP CANISTER VENT CONTROL VALVE-III

#### Ⓟ With CONSULT

1. Clean the air passage [portion (A) to (B)] of EVAP canister vent control valve using an air blower.
2. Perform "VENT CONTROL/V" in "ACTIVE TEST" mode.

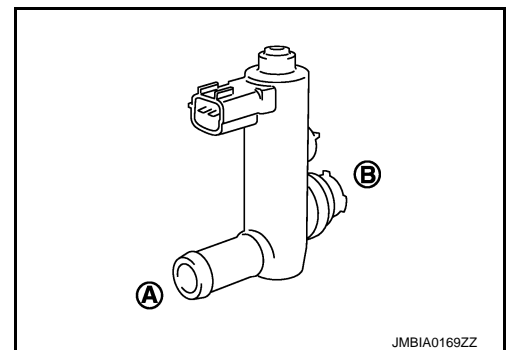

# P0447 EVAP CANISTER VENT CONTROL VALVE

[VQ37VHR FOR USA AND CANADA]

## < DTC/CIRCUIT DIAGNOSIS >

3. Check air passage continuity and operation delay time.  
**Make sure that new O-ring is installed properly.**

| Condition VENT CONT/V | Air passage continuity between (A) and (B) |
|-----------------------|--|
| ON                    | Not existed                                |
| OFF                   | Existed                                    |

**Operation takes less than 1 second.**

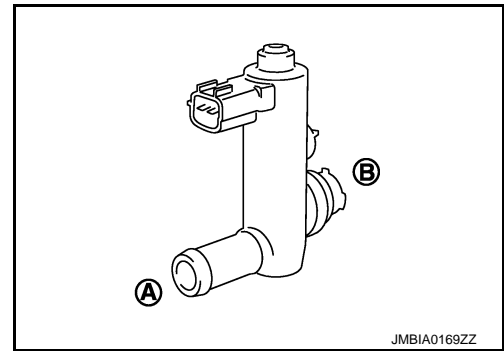

JMBIA0169ZZ

### Without CONSULT

1. Clean the air passage [portion (A) to (B)] of EVAP canister vent control valve using an air blower.
2. Check air passage continuity and operation delay time under the following conditions.

**Make sure that new O-ring is installed properly.**

| Condition  | Air passage continuity between (A) and (B) |
|--|--|
| 12 V direct current supply between terminals 1 and 2 | Not existed                                |
| OFF  | Existed                                    |

**Operation takes less than 1 second.**

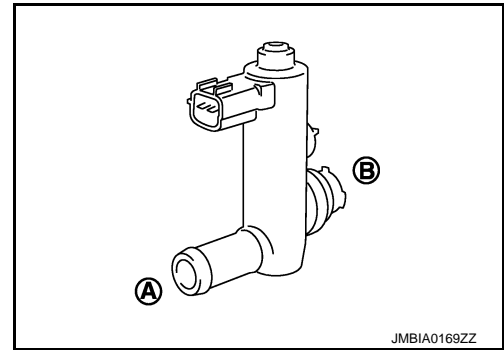

JMBIA0169ZZ

Is the inspection result normal?

YES >> INSPECTION END

NO >> Replace EVAP canister vent control valve. Refer to [FL-13, "Exploded View"](#).

A  
EC  
C  
D  
E  
F  
G  
H  
I  
J  
K  
L  
M  
N  
O  
P

# P0448 EVAP CANISTER VENT CONTROL VALVE

< DTC/CIRCUIT DIAGNOSIS >

[VQ37VHR FOR USA AND CANADA]

## P0448 EVAP CANISTER VENT CONTROL VALVE

### DTC Logic

INFOID:000000006882983

### DTC DETECTION LOGIC

| DTC No. | Trouble diagnosis name                 | DTC detecting condition   | Possible cause   |
|---------|--|---|--|
| P0448   | EVAP canister vent control valve close | EVAP canister vent control valve remains closed under specified driving conditions. | <ul style="list-style-type: none"><li>• EVAP canister vent control valve</li><li>• EVAP control system pressure sensor and the circuit</li><li>• Blocked rubber tube to EVAP canister vent control valve</li><li>• EVAP canister is saturated with water</li></ul> |

### DTC CONFIRMATION PROCEDURE

#### 1. PRECONDITIONING

If DTC Confirmation Procedure has been previously conducted, always perform the following procedure before conducting the next test.

1. Turn ignition switch OFF and wait at least 10 seconds.
2. Turn ignition switch ON.
3. Turn ignition switch OFF and wait at least 10 seconds.

>> GO TO 2.

#### 2. PERFORM DTC CONFIRMATION PROCEDURE

1. Turn ignition switch ON and wait at least 5 seconds.
2. Turn ignition switch OFF and wait at least 10 seconds.
3. Start engine and let it idle for at least 1 minute.
4. Repeat next procedures five times.
  - Increase the engine speed up to between 3,000 and 3,500 rpm and maintain that speed for 2 minutes.
- Do not exceed 2 minutes.**
  - Fully released accelerator pedal and keep engine idle for about 5 seconds.
5. Repeat next procedure 27 times.
  - Quickly increase the engine speed up to between 3,000 and 3,500 rpm and maintain that speed for 25 to 30 seconds.
  - Fully released accelerator pedal and keep engine idle for at least 35 seconds.

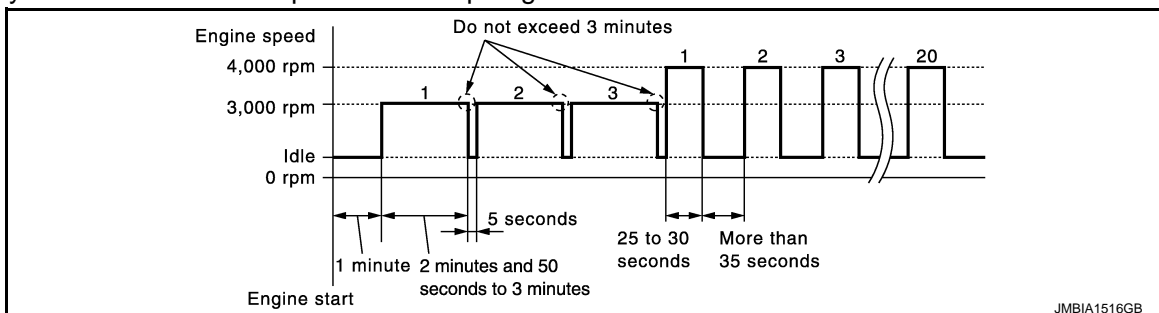

6. Check 1st trip DTC.

Is 1st trip DTC detected?

- YES >> Go to [EC-342, "Diagnosis Procedure"](#).  
NO >> INSPECTION END

### Diagnosis Procedure

INFOID:000000006882984

#### 1. CHECK RUBBER TUBE

1. Turn ignition switch OFF.
2. Disconnect rubber tube connected to EVAP canister vent control valve.
3. Check the rubber tube for clogging.

Is the inspection result normal?

- YES >> GO TO 2.

# P0448 EVAP CANISTER VENT CONTROL VALVE

[VQ37VHR FOR USA AND CANADA]

< DTC/CIRCUIT DIAGNOSIS >

NO >> Clean rubber tube using an air blower.

## 2.CHECK EVAP CANISTER VENT CONTROL VALVE

Refer to [EC-344, "Component Inspection"](#).

Is the inspection result normal?

YES >> GO TO 3.

NO >> Replace EVAP canister vent control valve. Refer to [FL-13, "Exploded View"](#).

## 3.CHECK IF EVAP CANISTER IS SATURATED WITH WATER

1. Remove EVAP canister with EVAP canister vent control valve (2) and EVAP control system pressure sensor attached.
2. Check if water will drain from the EVAP canister (1).

Does water drain from EVAP canister?

YES >> GO TO 4.

NO >> GO TO 6.

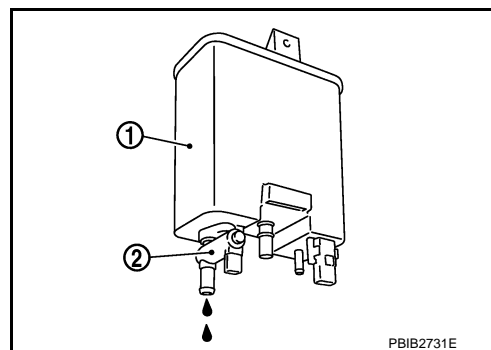

## 4.CHECK EVAP CANISTER

Weigh the EVAP canister with the EVAP canister vent control valve and EVAP control system pressure sensor attached.

**The weight should be less than 2.1 kg (4.6 lb).**

Is the inspection result normal?

YES >> GO TO 6.

NO >> GO TO 5.

## 5.DETECT MALFUNCTIONING PART

Check the following.

- EVAP canister for damage
- EVAP hose between EVAP canister and vehicle frame for clogging or poor connection

>> Repair hose or replace EVAP canister.

## 6.CHECK EVAP CONTROL SYSTEM PRESSURE SENSOR CONNECTOR

1. Disconnect EVAP control system pressure sensor harness connector.
2. Check connectors for water.

**Water should not exist.**

Is the inspection result normal?

YES >> GO TO 7.

NO >> Replace EVAP control system pressure sensor. Refer to [FL-13, "Exploded View"](#).

## 7.CHECK EVAP CONTROL SYSTEM PRESSURE SENSOR

Refer to [EC-349, "Component Inspection"](#).

Is the inspection result normal?

YES >> GO TO 8.

NO >> Replace EVAP control system pressure sensor. Refer to [FL-13, "Exploded View"](#).

## 8.CHECK INTERMITTENT INCIDENT

Refer to [GI-44, "Intermittent Incident"](#).

>> INSPECTION END

# P0448 EVAP CANISTER VENT CONTROL VALVE

[VQ37VHR FOR USA AND CANADA]

< DTC/CIRCUIT DIAGNOSIS >

INFOID:00000006882985

## Component Inspection

### 1. CHECK EVAP CANISTER VENT CONTROL VALVE-I

1. Turn ignition switch OFF.
2. Remove EVAP canister vent control valve from EVAP canister. Refer to [FL-13, "Exploded View"](#).
3. Check portion (A) of EVAP canister vent control valve for being rusted.

Is it rusted?

- YES >> Replace EVAP canister vent control valve. Refer to [FL-13, "Exploded View"](#).
- NO >> GO TO 2.

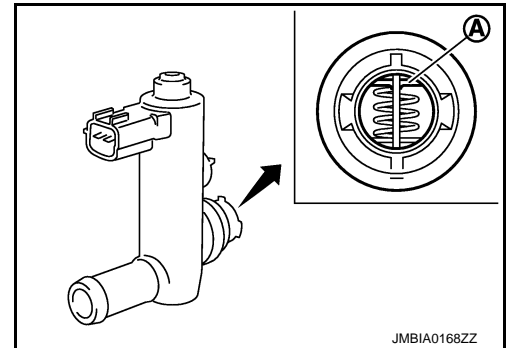

### 2. CHECK EVAP CANISTER VENT CONTROL VALVE-II

#### Ⓟ With CONSULT

1. Reconnect harness connectors disconnected.
2. Turn ignition switch ON.
3. Perform "VENT CONTROL/V" in "ACTIVE TEST" mode.
4. Check air passage continuity and operation delay time.  
**Make sure that new O-ring is installed properly.**

| Condition VENT CONT/V | Air passage continuity between (A) and (B) |
|-----------------------|--|
| ON                    | Not existed                                |
| OFF                   | Existed                                    |

**Operation takes less than 1 second.**

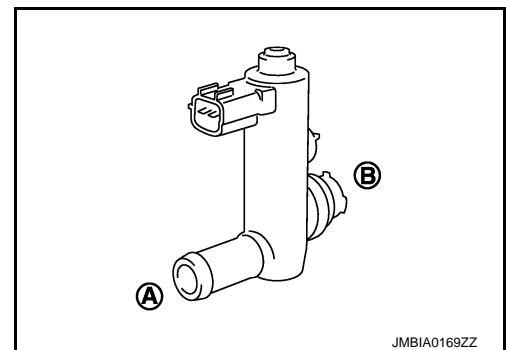

#### ⓧ Without CONSULT

1. Disconnect EVAP canister vent control valve harness connector.
2. Check air passage continuity and operation delay time under the following conditions.  
**Make sure that new O-ring is installed properly.**

| Condition  | Air passage continuity between (A) and (B) |
|--|--|
| 12 V direct current supply between terminals 1 and 2 | Not existed                                |
| OFF  | Existed                                    |

**Operation takes less than 1 second.**

Is the inspection result normal?

- YES >> INSPECTION END
- NO >> GO TO 3.

### 3. CHECK EVAP CANISTER VENT CONTROL VALVE-III

#### Ⓟ With CONSULT

1. Clean the air passage [portion (A) to (B)] of EVAP canister vent control valve using an air blower.
2. Perform "VENT CONTROL/V" in "ACTIVE TEST" mode.

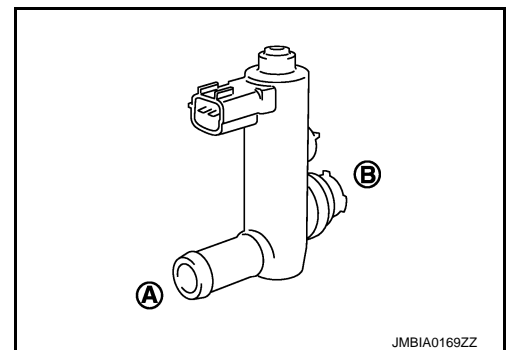



# P0448 EVAP CANISTER VENT CONTROL VALVE

[VQ37VHR FOR USA AND CANADA]

## < DTC/CIRCUIT DIAGNOSIS >

3. Check air passage continuity and operation delay time.  
**Make sure that new O-ring is installed properly.**

| Condition VENT CONT/V | Air passage continuity between (A) and (B) |
|-----------------------|--|
| ON                    | Not existed                                |
| OFF                   | Existed                                    |

**Operation takes less than 1 second.**

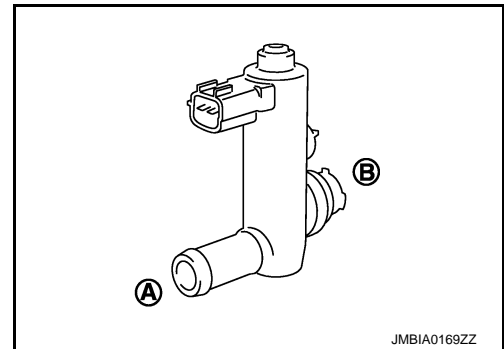

JMBIA0169ZZ

### Without CONSULT

1. Clean the air passage [portion (A) to (B)] of EVAP canister vent control valve using an air blower.
2. Check air passage continuity and operation delay time under the following conditions.

**Make sure that new O-ring is installed properly.**

| Condition  | Air passage continuity between (A) and (B) |
|--|--|
| 12 V direct current supply between terminals 1 and 2 | Not existed                                |
| OFF  | Existed                                    |

**Operation takes less than 1 second.**

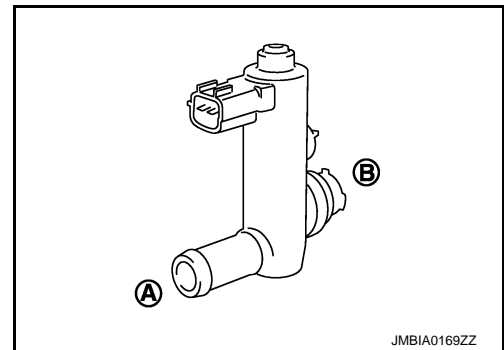

JMBIA0169ZZ

Is the inspection result normal?

YES >> INSPECTION END

NO >> Replace EVAP canister vent control valve. Refer to [FL-13, "Exploded View"](#).

A  
EC  
C  
D  
E  
F  
G  
H  
I  
J  
K  
L  
M  
N  
O  
P

# P0451 EVAP CONTROL SYSTEM PRESSURE SENSOR

< DTC/CIRCUIT DIAGNOSIS >

[VQ37VHR FOR USA AND CANADA]

## P0451 EVAP CONTROL SYSTEM PRESSURE SENSOR

### DTC Logic

INFOID:000000006882986

### DTC DETECTION LOGIC

| DTC No. | Trouble diagnosis name                          | DTC detecting condition  | Possible cause   |
|---------|---|--|--|
| P0451   | EVAP control system pressure sensor performance | ECM detects a sloshing signal from the EVAP control system pressure sensor | <ul style="list-style-type: none"><li>• Harness or connectors (EVAP control system pressure sensor circuit is shorted.) [CKP sensor (POS) circuit is shorted.] (APP sensor 2 circuit is shorted.) [CMP sensor (PHASE) (bank 2) circuit is open or shorted.] (Battery current sensor circuit is open or shorted.) (Refrigerant pressure sensor circuit is shorted.)</li><li>• EVAP control system pressure sensor</li><li>• Crankshaft position sensor (POS)</li><li>• Accelerator pedal position sensor</li><li>• Camshaft position sensor (PHASE) (bank 2)</li><li>• Battery current sensor</li><li>• Refrigerant pressure sensor</li></ul> |

### DTC CONFIRMATION PROCEDURE

#### NOTE:

**Never remove fuel filler cap during DTC confirmation procedure.**

#### 1. PRECONDITIONING

If DTC Confirmation Procedure has been previously conducted, always perform the following procedure before conducting the next test.

1. Turn ignition switch OFF and wait at least 10 seconds.
2. Turn ignition switch ON.
3. Turn ignition switch OFF and wait at least 10 seconds.

With CONSULT>>GO TO 2.

Without CONSULT>>GO TO 5.

#### 2. PERFORM DTC CONFIRMATION PROCEDURE-I

Ⓜ With CONSULT

1. Start engine and let it idle for least 40 seconds.

#### NOTE:

**Do not depress accelerator pedal even slightly.**

2. Check 1st trip DTC.

Is 1st trip DTC detected?

YES >> Proceed to [EC-347, "Diagnosis Procedure"](#).

NO >> GO TO 3.

#### 3. PERFORM DTC CONFIRMATION PROCEDURE-II

Ⓜ With CONSULT

1. Select "EVAP DIAG READY" in "DATA MONITOR" mode of "ENGINE".
2. Let it idle until "OFF" of "EVAP DIAG READY" changes to "ON".

#### NOTE:

**It will take at most 2 hours until "OFF" of "EVAP DIAG READY" changes to "ON".**

3. Turn ignition switch OFF and wait at least 90 minutes.

#### NOTE:

**Never turn ignition switch ON during 90 minutes.**

4. Turn ignition switch ON.
5. Select "EVAP LEAK DIAG" in "DATA MONITOR" mode of "ENGINE".
6. Check that "EVAP LEAK DIAG" indication.

Which is displayed on CONSULT?

CMPLT >> GO TO 4.

# P0451 EVAP CONTROL SYSTEM PRESSURE SENSOR

[VQ37VHR FOR USA AND CANADA]

< DTC/CIRCUIT DIAGNOSIS >

- YET >> 1. Perform DTC CONFIRMATION PROCEDURE again.  
2. GO TO 1.

## 4.PERFORM DTC CONFIRMATION PROCEDURE-III

 With CONSULT  
Check 1st trip DTC.

Is 1st trip DTC detected?

- YES >> Proceed to [EC-347, "Diagnosis Procedure"](#).  
NO >> INSPECTION END

## 5.PERFORM DTC CONFIRMATION PROCEDURE-IV

 With GST

1. Start engine and let it idle for least 40 seconds.

**NOTE:**

**Do not depress accelerator pedal even slightly.**

2. Check 1st trip DTC.

Is 1st trip DTC detected?

- YES >> Proceed to [EC-347, "Diagnosis Procedure"](#).  
NO >> GO TO 6.

## 6.PERFORM DTC CONFIRMATION PROCEDURE-V

 With GST

1. Let it idle for at least 2 hours.  
2. Turn ignition switch OFF and wait at least 90 minutes.

**NOTE:**

**Never turn ignition switch ON during 90 minutes.**

3. Turn ignition switch ON.  
4. Check 1st trip DTC.

Is 1st trip DTC detected?

- YES >> Proceed to [EC-347, "Diagnosis Procedure"](#).  
NO >> INSPECTION END

## Diagnosis Procedure

INFOID:000000006882987

### 1.CHECK GROUND CONNECTION

1. Turn ignition switch OFF.  
2. Check ground connection M95. Refer to Ground Inspection in [GI-47, "Circuit Inspection"](#).

Is the inspection result normal?

- YES >> GO TO 2.  
NO >> Repair or replace ground connection.

### 2.CHECK EVAP CONTROL SYSTEM PRESSURE SENSOR CONNECTOR FOR WATER

1. Disconnect EVAP control system pressure sensor harness connector.  
2. Check sensor harness connector for water.

**Water should not exist.**

Is the inspection result normal?

- YES >> GO TO 3.  
NO >> Repair or replace harness connector.

### 3.CHECK EVAP CONTROL SYSTEM PRESSURE SENSOR POWER SUPPLY CIRCUIT

1. Turn ignition switch ON.  
2. Check the voltage between EVAP control system pressure sensor harness connector and ground.

# P0451 EVAP CONTROL SYSTEM PRESSURE SENSOR

< DTC/CIRCUIT DIAGNOSIS >

[VQ37VHR FOR USA AND CANADA]

| EVAP control system pressure sensor |          | Ground | Voltage (V) |
|-------------------------------------|----------|--------|-------------|
| Connector                           | Terminal |        |             |
| B73                                 | 3        | Ground | Approx. 5   |

Is the inspection result normal?

YES >> GO TO 8.

NO >> GO TO 4.

## 4.CHECK SENSOR POWER SUPPLY CIRCUIT

Check harness for short to power and short to ground, between the following terminals.

| ECM       |          | Sensor                              |                    |                 |
|-----------|----------|-------------------------------------|--------------------|-----------------|
| Connector | Terminal | Name                                | Connector          | Terminal        |
| F101      | 46       | CKP sensor (POS)                    | F2                 | 1               |
| F102      | 64       | CMP sensor (PHASE) (bank 2)         | F18                | 1               |
|           |          | Battery current sensor              | E21                |                 |
| M107      | 103      | APP sensor                          | M153 <sup>*1</sup> | 3 <sup>*1</sup> |
|           |          |                                     | M9 <sup>*2</sup>   | 6 <sup>*2</sup> |
|           | 107      | EVAP control system pressure sensor | B73                | 3               |
|           |          | Refrigerant pressure sensor         | E77                | 3               |

\*1: With ICC

\*2: Without ICC

Is the inspection result normal?

YES >> GO TO 5.

NO >> Repair short to ground or short to power in harness or connectors.

## 5.CHECK COMPONENTS

Check the following.

- Crankshaft position sensor (POS) (Refer to [EC-314, "Component Inspection"](#).)
- Camshaft position sensor (PHASE) (bank 2) (Refer to [EC-319, "Component Inspection"](#).)
- Battery current sensor (Refer to [EC-437, "Component Inspection"](#).)
- Refrigerant pressure sensor (Refer to [EC-530, "Diagnosis Procedure"](#).)

Is the inspection result normal?

YES >> GO TO 6.

NO >> Replace malfunctioning component.

## 6.CHECK APP SENSOR

Refer to [EC-487, "Component Inspection"](#).

Is the inspection result normal?

YES >> GO TO 9.

NO >> GO TO 7.

## 7.REPLACE ACCELERATOR PEDAL ASSEMBLY

1. Replace accelerator pedal assembly
2. Go to [EC-487, "Special Repair Requirement"](#).

>> INSPECTION END

## 8.CHECK EVAP CONTROL SYSTEM PRESSURE SENSOR

Refer to [EC-349, "Component Inspection"](#).

Is the inspection result normal?

YES >> GO TO 9.

NO >> Replace EVAP control system pressure sensor. Refer to [FL-13, "Exploded View"](#).

# P0451 EVAP CONTROL SYSTEM PRESSURE SENSOR

< DTC/CIRCUIT DIAGNOSIS >

[VQ37VHR FOR USA AND CANADA]

## 9. CHECK INTERMITTENT INCIDENT

Refer to [GI-44. "Intermittent Incident"](#).

>> INSPECTION END

## Component Inspection

INFOID:000000006882988

## 1. CHECK EVAP CONTROL SYSTEM PRESSURE SENSOR

1. Turn ignition switch OFF.
2. Remove EVAP control system pressure sensor with its harness connector.  
**Always replace O-ring with a new one.**
3. Install a vacuum pump to EVAP control system pressure sensor.
4. Turn ignition switch ON and check output voltage between ECM harness connector terminals under the following conditions.

| Connector | ECM      |          | Condition<br>[Applied vacuum kPa (kg/cm <sup>2</sup> , psi)] | Voltage (V)                       |
|-----------|----------|----------|--|-----------------------------------|
|           | +        | -        |  |                                   |
|           | Terminal | Terminal |  |                                   |
| M107      | 102      | 112      | Not applied  | 1.8 - 4.8                         |
|           |          |          | -26.7 (-0.272, -3.87)  | 2.1 to 2.5 lower than above value |

### CAUTION:

- Always calibrate the vacuum pump gauge when using it.
- Never apply below -93.3 kPa (-0.952 kg/cm<sup>2</sup>, -13.53 psi) or pressure over 101.3 kPa (1.033 kg/cm<sup>2</sup>, 14.69 psi).

Is the inspection result normal?

YES >> INSPECTION END

NO >> Replace EVAP control system pressure sensor. Refer to [FL-13. "Exploded View"](#).

# P0452 EVAP CONTROL SYSTEM PRESSURE SENSOR

< DTC/CIRCUIT DIAGNOSIS >

[VQ37VHR FOR USA AND CANADA]

## P0452 EVAP CONTROL SYSTEM PRESSURE SENSOR

### DTC Logic

INFOID:00000006882989

### DTC DETECTION LOGIC

| DTC No. | Trouble diagnosis name                        | DTC detecting condition                                    | Possible cause   |
|---------|---|--|--|
| P0452   | EVAP control system pressure sensor low input | An excessively low voltage from the sensor is sent to ECM. | <ul style="list-style-type: none"> <li>• Harness or connectors<br/>(EVAP control system pressure sensor circuit is open or shorted.)<br/>[CKP sensor (POS) circuit is shorted.]<br/>(APP sensor 2 circuit is shorted.)<br/>[CMP sensor (PHASE) (bank 2) circuit is open or shorted.]<br/>(Battery current sensor circuit is open or shorted.)<br/>(Refrigerant pressure sensor circuit is shorted.)</li> <li>• EVAP control system pressure sensor</li> <li>• Crankshaft position sensor (POS)</li> <li>• Accelerator pedal position sensor</li> <li>• Camshaft position sensor (PHASE) (bank 2)</li> <li>• Battery current sensor</li> <li>• Refrigerant pressure sensor</li> </ul> |

### DTC CONFIRMATION PROCEDURE

#### 1. PRECONDITIONING

If DTC Confirmation Procedure has been previously conducted, always perform the following procedure before conducting the next test.

1. Turn ignition switch OFF and wait at least 10 seconds.
2. Turn ignition switch ON.
3. Turn ignition switch OFF and wait at least 10 seconds.

#### TESTING CONDITION:

**Always perform test at a temperature of 5°C (41°F) or more.**

>> GO TO 2.

#### 2. PERFORM DTC CONFIRMATION PROCEDURE

##### With CONSULT

1. Start engine and warm it up to normal operating temperature.
2. Turn ignition switch OFF and wait at least 10 seconds.
3. Turn ignition switch ON.
4. Turn ignition switch OFF and wait at least 10 seconds.
5. Turn ignition switch ON.
6. Select "DATA MONITOR" mode with CONSULT.
7. Make sure that "FUEL T/TMP SE" is more than 0°C (32°F).
8. Start engine and wait at least 20 seconds.
9. Check 1st trip DTC.

##### With GST

1. Start engine and warm it up to normal operating temperature.
2. Set voltmeter probes to ECM harness connector terminals as per the following.

| ECM       |  |                     |
|-----------|--|---------------------|
| Connector | +  | -                   |
|           | Terminal                                     | Terminal            |
| M107      | 106<br>(Fuel tank temperature sensor signal) | 128<br>(ECM ground) |

3. Make sure that the voltage is less than 4.2 V.
4. Turn ignition switch OFF and wait at least 10 seconds.
5. Turn ignition switch ON.
6. Turn ignition switch OFF and wait at least 10 seconds.

# P0452 EVAP CONTROL SYSTEM PRESSURE SENSOR

[VQ37VHR FOR USA AND CANADA]

## < DTC/CIRCUIT DIAGNOSIS >

7. Start engine and wait at least 20 seconds.
8. Check 1st trip DTC.

Is 1st trip DTC detected?

- YES >> Go to [EC-351, "Diagnosis Procedure"](#).  
NO >> INSPECTION END

## Diagnosis Procedure

INFOID:000000006882990

### 1.CHECK GROUND CONNECTION

1. Turn ignition switch OFF.
2. Check ground connection M95. Refer to Ground Inspection in [GI-47, "Circuit Inspection"](#).

Is the inspection result normal?

- YES >> GO TO 2.  
NO >> Repair or replace ground connection.

### 2.CHECK CONNECTOR

1. Disconnect EVAP control system pressure sensor harness connector.
2. Check sensor harness connector for water.

**Water should not exist.**

Is the inspection result normal?

- YES >> GO TO 3.  
NO >> Repair or replace harness connector.

### 3.CHECK EVAP CONTROL SYSTEM PRESSURE SENSOR POWER SUPPLY CIRCUIT-I

1. Turn ignition switch ON.
2. Check the voltage between EVAP control system pressure sensor harness connector and ground.

| EVAP control system pressure sensor |          | Ground | Voltage (V) |
|-------------------------------------|----------|--------|-------------|
| Connector                           | Terminal |        |             |
| B73                                 | 3        | Ground | Approx. 5   |

Is the inspection result normal?

- YES >> GO TO 10.  
NO >> GO TO 4.

### 4.CHECK EVAP CONTROL SYSTEM PRESSURE SENSOR POWER SUPPLY CIRCUIT-II

1. Turn ignition switch OFF.
2. Disconnect ECM harness connector.
3. Check the continuity between EVAP control system pressure sensor harness connector and ECM harness connector.

| EVAP control system pressure sensor |          | ECM       |          | Continuity |
|-------------------------------------|----------|-----------|----------|------------|
| Connector                           | Terminal | Connector | Terminal |            |
| B73                                 | 3        | M107      | 107      | Existed    |

Is the inspection result normal?

- YES >> GO TO 6.  
NO >> GO TO 5.

### 5.DETECT MALFUNCTIONING PART

Check the following.

- Harness connectors M7, B1
- Harness connectors B71, B72
- Harness for open between ECM and EVAP control system pressure sensor

>> Repair open circuit.

# P0452 EVAP CONTROL SYSTEM PRESSURE SENSOR

< DTC/CIRCUIT DIAGNOSIS >

[VQ37VHR FOR USA AND CANADA]

## 6. CHECK SENSOR POWER SUPPLY CIRCUIT

Check harness for short to power and short to ground, between the following terminals.

| ECM       |          | Sensor                              |  |                                    |
|-----------|----------|-------------------------------------|--|------------------------------------|
| Connector | Terminal | Name                                | Connector                              | Terminal                           |
| F101      | 46       | CKP sensor (POS)                    | F2                                     | 1                                  |
| F102      | 64       | CMP sensor (PHASE) (bank 2)         | F18                                    | 1                                  |
|           |          | Battery current sensor              | E21                                    |                                    |
| M107      | 103      | APP sensor                          | M153 <sup>*1</sup><br>M9 <sup>*2</sup> | 3 <sup>*1</sup><br>6 <sup>*2</sup> |
|           |          | EVAP control system pressure sensor | B73                                    | 3                                  |
|           | 107      | Refrigerant pressure sensor         | E77                                    | 3                                  |

\*1: With ICC

\*2: Without ICC

Is the inspection result normal?

YES >> GO TO 7.

NO >> Repair short to ground or short to power in harness or connectors.

## 7. CHECK COMPONENTS

Check the following.

- Crankshaft position sensor (POS) (Refer to [EC-314, "Component Inspection"](#).)
- Camshaft position sensor (PHASE) (bank 2) (Refer to [EC-319, "Component Inspection"](#).)
- Battery current sensor (Refer to [EC-437, "Component Inspection"](#).)
- Refrigerant pressure sensor (Refer to [EC-530, "Diagnosis Procedure"](#).)

Is the inspection result normal?

YES >> GO TO 8.

NO >> Replace malfunctioning component.

## 8. CHECK APP SENSOR

Refer to [EC-487, "Component Inspection"](#).

Is the inspection result normal?

YES >> GO TO 15.

NO >> GO TO 9.

## 9. REPLACE ACCELERATOR PEDAL ASSEMBLY

1. Replace accelerator pedal assembly
2. Go to [EC-487, "Special Repair Requirement"](#).

>> INSPECTION END

## 10. CHECK EVAP CONTROL SYSTEM PRESSURE SENSOR GROUND CIRCUIT FOR OPEN AND SHORT

1. Turn ignition switch OFF.
2. Disconnect ECM harness connector.
3. Check the continuity between EVAP control system pressure sensor harness connector and ECM harness connector.

| EVAP control system pressure sensor |          | ECM       |          | Continuity |
|-------------------------------------|----------|-----------|----------|------------|
| Connector                           | Terminal | Connector | Terminal |            |
| B73                                 | 1        | M107      | 112      | Existed    |

4. Also check harness for short to ground and short to power.

Is the inspection result normal?



# P0452 EVAP CONTROL SYSTEM PRESSURE SENSOR

[VQ37VHR FOR USA AND CANADA]

< DTC/CIRCUIT DIAGNOSIS >

- YES >> GO TO 12.
- NO >> GO TO 11.

## 11. DETECT MALFUNCTIONING PART

Check the following.

- Harness connectors B1, M7
- Harness connectors B71, B72
- Harness for open or short between EVAP control system pressure sensor and ECM

>> Repair open circuit, short to ground or short to power in harness or connectors.

## 12. CHECK EVAP CONTROL SYSTEM PRESSURE SENSOR INPUT SIGNAL CIRCUIT FOR OPEN AND SHORT

1. Check the continuity between EVAP control system pressure sensor harness connector and ECM harness connector.

| EVAP control system pressure sensor |          | ECM       |          | Continuity |
|-------------------------------------|----------|-----------|----------|------------|
| Connector                           | Terminal | Connector | Terminal |            |
| B73                                 | 2        | M107      | 102      | Existed    |

2. Also check harness for short to ground and short to power.

Is the inspection result normal?

- YES >> GO TO 14.
- NO >> GO TO 13.

## 13. DETECT MALFUNCTIONING PART

Check the following.

- Harness connectors B1, M7
- Harness connectors B71, B72
- Harness for open or short between EVAP control system pressure sensor and ECM

>> Repair open circuit, short to ground or short to power in harness or connectors.

## 14. CHECK EVAP CONTROL SYSTEM PRESSURE SENSOR

Refer to [EC-353, "Component Inspection"](#).

Is the inspection result normal?

- YES >> GO TO 15.
- NO >> Replace EVAP control system pressure sensor. Refer to [FL-13, "Exploded View"](#).

## 15. CHECK INTERMITTENT INCIDENT

Refer to [GI-44, "Intermittent Incident"](#).

>> INSPECTION END

## Component Inspection

INFOID:000000006882991

### 1. CHECK EVAP CONTROL SYSTEM PRESSURE SENSOR

1. Turn ignition switch OFF.
2. Remove EVAP control system pressure sensor with its harness connector.  
**Always replace O-ring with a new one.**
3. Install a vacuum pump to EVAP control system pressure sensor.
4. Turn ignition switch ON and check output voltage between ECM harness connector terminals under the following conditions.

# P0452 EVAP CONTROL SYSTEM PRESSURE SENSOR

< DTC/CIRCUIT DIAGNOSIS >

[VQ37VHR FOR USA AND CANADA]

| ECM       |          |          | Condition<br>[Applied vacuum kPa (kg/cm <sup>2</sup> , psi)] | Voltage (V)                       |
|-----------|----------|----------|--|-----------------------------------|
| Connector | +        | -        |  |                                   |
|           | Terminal | Terminal |  |                                   |
| M107      | 102      | 112      | Not applied  | 1.8 - 4.8                         |
|           |          |          | -26.7 (-0.272, -3.87)  | 2.1 to 2.5 lower than above value |

**CAUTION:**

- Always calibrate the vacuum pump gauge when using it.
- Never apply below -93.3 kPa (-0.952 kg/cm<sup>2</sup>, -13.53 psi) or pressure over 101.3 kPa (1.033 kg/cm<sup>2</sup>, 14.69 psi).

Is the inspection result normal?

YES >> INSPECTION END

NO >> Replace EVAP control system pressure sensor. Refer to [FL-13, "Exploded View"](#).

# P0453 EVAP CONTROL SYSTEM PRESSURE SENSOR

< DTC/CIRCUIT DIAGNOSIS >

[VQ37VHR FOR USA AND CANADA]

## P0453 EVAP CONTROL SYSTEM PRESSURE SENSOR

### DTC Logic

INFOID:000000006882992

### DTC DETECTION LOGIC

| DTC No. | Trouble diagnosis name                         | DTC detecting condition                                     | Possible cause  |
|---------|--|---|---|
| P0453   | EVAP control system pressure sensor high input | An excessively high voltage from the sensor is sent to ECM. | <ul style="list-style-type: none"> <li>• Harness or connectors (EVAP control system pressure sensor circuit is open or shorted.) [CKP sensor (POS) circuit is shorted.] (APP sensor 2 circuit is shorted.) [CMP sensor (PHASE) (bank 2) circuit is open or shorted.] (Battery current sensor circuit is open or shorted.) (Refrigerant pressure sensor circuit is shorted.)</li> <li>• EVAP control system pressure sensor</li> <li>• Crankshaft position sensor (POS)</li> <li>• Accelerator pedal position sensor</li> <li>• Camshaft position sensor (PHASE) (bank 2)</li> <li>• Battery current sensor</li> <li>• Refrigerant pressure sensor</li> <li>• EVAP canister vent control valve</li> <li>• EVAP canister</li> <li>• Rubber hose from EVAP canister vent control valve to vehicle frame</li> </ul> |

### DTC CONFIRMATION PROCEDURE

#### 1. PRECONDITIONING

If DTC Confirmation Procedure has been previously conducted, always perform the following procedure before conducting the next test.

1. Turn ignition switch OFF and wait at least 10 seconds.
2. Turn ignition switch ON.
3. Turn ignition switch OFF and wait at least 10 seconds.

#### TESTING CONDITION:

**Always perform test at a temperature of 5°C (41°F) or more.**

>> GO TO 2.

#### 2. PERFORM DTC CONFIRMATION PROCEDURE

##### With CONSULT

1. Start engine and warm it up to normal operating temperature.
2. Turn ignition switch OFF and wait at least 10 seconds.
3. Turn ignition switch ON.
4. Turn ignition switch OFF and wait at least 10 seconds.
5. Turn ignition switch ON.
6. Select "DATA MONITOR" mode with CONSULT.
7. Make sure that "FUEL T/TMP SE" is more than 0°C (32°F).
8. Start engine and wait at least 20 seconds.
9. Check 1st trip DTC.

##### With GST

1. Start engine and warm it up to normal operating temperature.
2. Set voltmeter probes to ECM harness connector terminals as per the following.

| ECM       |  |                     |
|-----------|--|---------------------|
| Connector | +  | -                   |
|           | Terminal                                     | Terminal            |
| M107      | 106<br>(Fuel tank temperature sensor signal) | 128<br>(ECM ground) |

3. Make sure that the voltage is less than 4.2 V.

# P0453 EVAP CONTROL SYSTEM PRESSURE SENSOR

[VQ37VHR FOR USA AND CANADA]

## < DTC/CIRCUIT DIAGNOSIS >

4. Turn ignition switch OFF and wait at least 10 seconds.
5. Turn ignition switch ON.
6. Turn ignition switch OFF and wait at least 10 seconds.
7. Start engine and wait at least 20 seconds.
8. Check 1st trip DTC.

### Is 1st trip DTC detected?

- YES >> Go to [EC-356, "Diagnosis Procedure"](#).  
NO >> INSPECTION END

## Diagnosis Procedure

INFOID:000000006882993

### 1.CHECK GROUND CONNECTION

1. Turn ignition switch OFF.
2. Check ground connection M95. Refer to Ground Inspection in [GI-47, "Circuit Inspection"](#).

#### Is the inspection result normal?

- YES >> GO TO 2.  
NO >> Repair or replace ground connection.

### 2.CHECK CONNECTOR

1. Disconnect EVAP control system pressure sensor harness connector.
2. Check sensor harness connector for water.

**Water should not exist.**

#### Is the inspection result normal?

- YES >> GO TO 3.  
NO >> Repair or replace harness connector.

### 3.CHECK EVAP CONTROL SYSTEM PRESSURE SENSOR POWER SUPPLY CIRCUIT

1. Turn ignition switch ON.
2. Check the voltage between EVAP control system pressure sensor harness connector and ground.

| EVAP control system pressure sensor |          | Ground | Voltage (V) |
|-------------------------------------|----------|--------|-------------|
| Connector                           | Terminal |        |             |
| B73                                 | 3        | Ground | Approx. 5   |

#### Is the inspection result normal?

- YES >> GO TO 10.  
NO >> GO TO 4.

### 4.CHECK EVAP CONTROL SYSTEM PRESSURE SENSOR POWER SUPPLY CIRCUIT-II

1. Turn ignition switch OFF.
2. Disconnect ECM harness connector.
3. Check the continuity between EVAP control system pressure sensor harness connector and ECM harness connector.

| EVAP control system pressure sensor |          | ECM       |          | Continuity |
|-------------------------------------|----------|-----------|----------|------------|
| Connector                           | Terminal | Connector | Terminal |            |
| B73                                 | 3        | M107      | 107      | Existed    |

#### Is the inspection result normal?

- YES >> GO TO 6.  
NO >> GO TO 5.

### 5.DETECT MALFUNCTIONING PART

Check the following.

- Harness connectors M7, B1
- Harness connectors B71, B72

# P0453 EVAP CONTROL SYSTEM PRESSURE SENSOR

< DTC/CIRCUIT DIAGNOSIS >

[VQ37VHR FOR USA AND CANADA]

- Harness for open between ECM and EVAP control system pressure sensor

>> Repair open circuit.

## 6. CHECK SENSOR POWER SUPPLY CIRCUIT

Check harness for short to power and short to ground, between the following terminals.

| ECM       |          | Sensor                              |                |            |
|-----------|----------|-------------------------------------|----------------|------------|
| Connector | Terminal | Name                                | Connector      | Terminal   |
| F101      | 46       | CKP sensor (POS)                    | F2             | 1          |
| F102      | 64       | CMP sensor (PHASE) (bank 2)         | F18            | 1          |
|           |          | Battery current sensor              | E21            |            |
| M107      | 103      | APP sensor                          | M153*1<br>M9*2 | 3*1<br>6*2 |
|           |          | EVAP control system pressure sensor | B73            | 3          |
|           | 107      | Refrigerant pressure sensor         | E77            | 3          |

\*1: With ICC

\*2: Without ICC

Is the inspection result normal?

YES >> GO TO 7.

NO >> Repair short to ground or short to power in harness or connectors.

## 7. CHECK COMPONENTS

Check the following.

- Crankshaft position sensor (POS) (Refer to [EC-314, "Component Inspection"](#).)
- Camshaft position sensor (PHASE) (bank 2) (Refer to [EC-319, "Component Inspection"](#).)
- Battery current sensor (Refer to [EC-437, "Component Inspection"](#).)
- Refrigerant pressure sensor (Refer to [EC-530, "Diagnosis Procedure"](#).)

Is the inspection result normal?

YES >> GO TO 8.

NO >> Replace malfunctioning component.

## 8. CHECK APP SENSOR

Refer to [EC-487, "Component Inspection"](#).

Is the inspection result normal?

YES >> GO TO 20.

NO >> GO TO 9.

## 9. REPLACE ACCELERATOR PEDAL ASSEMBLY

1. Replace accelerator pedal assembly
2. Go to [EC-487, "Special Repair Requirement"](#).

>> INSPECTION END

## 10. CHECK EVAP CONTROL SYSTEM PRESSURE SENSOR GROUND CIRCUIT FOR OPEN AND SHORT

1. Turn ignition switch OFF.
2. Disconnect ECM harness connector.
3. Check the continuity between EVAP control system pressure sensor harness connector and ECM harness connector.

| EVAP control system pressure sensor |          | ECM       |          | Continuity |
|-------------------------------------|----------|-----------|----------|------------|
| Connector                           | Terminal | Connector | Terminal |            |
| B73                                 | 1        | M107      | 112      | Existed    |

# P0453 EVAP CONTROL SYSTEM PRESSURE SENSOR

[VQ37VHR FOR USA AND CANADA]

< DTC/CIRCUIT DIAGNOSIS >

4. Also check harness for short to ground and short to power.

Is the inspection result normal?

- YES >> GO TO 12.
- NO >> GO TO 11.

## 11.DETECT MALFUNCTIONING PART

Check the following.

- Harness connectors B1, M7
- Harness connectors B71, B72
- Harness for open or short between EVAP control system pressure sensor and ECM

>> Repair open circuit, short to ground or short to power in harness or connectors.

## 12.CHECK EVAP CONTROL SYSTEM PRESSURE SENSOR INPUT SIGNAL CIRCUIT FOR OPEN AND SHORT

1. Check the continuity between EVAP control system pressure sensor harness connector and ECM harness connector.

| EVAP control system pressure sensor |          | ECM       |          | Continuity |
|-------------------------------------|----------|-----------|----------|------------|
| Connector                           | Terminal | Connector | Terminal |            |
| B73                                 | 2        | M107      | 102      | Existed    |

2. Also check harness for short to ground and short to power.

Is the inspection result normal?

- YES >> GO TO 14.
- NO >> GO TO 13.

## 13.DETECT MALFUNCTIONING PART

Check the following.

- Harness connectors B1, M7
- Harness connectors B71, B72
- Harness for open or short between EVAP control system pressure sensor and ECM

>> Repair open circuit, short to ground or short to power in harness or connectors.

## 14.CHECK RUBBER TUBE

1. Disconnect rubber tube connected to EVAP canister vent control valve.

2. Check the rubber tube for clogging.

Is the inspection result normal?

- YES >> GO TO 15.
- NO >> Clean the rubber tube using an air blower, repair or replace rubber tube.

## 15.CHECK EVAP CANISTER VENT CONTROL VALVE

Refer to [EC-340, "Component Inspection"](#).

Is the inspection result normal?

- YES >> GO TO 16.
- NO >> Replace EVAP canister vent control valve. Refer to [FL-13, "Exploded View"](#).

## 16.CHECK EVAP CONTROL SYSTEM PRESSURE SENSOR

Refer to [EC-359, "Component Inspection"](#).

Is the inspection result normal?

- YES >> GO TO 17.
- NO >> Replace EVAP control system pressure sensor. Refer to [FL-13, "Exploded View"](#).

## 17.CHECK IF EVAP CANISTER IS SATURATED WITH WATER

1. Remove EVAP canister with EVAP canister vent control valve and EVAP control system pressure sensor attached.

# P0453 EVAP CONTROL SYSTEM PRESSURE SENSOR

[VQ37VHR FOR USA AND CANADA]

## < DTC/CIRCUIT DIAGNOSIS >

2. Check if water will drain from the EVAP canister (1).

2 : EVAP canister vent control valve

### Does water drain from EVAP canister?

- YES >> GO TO 18.
- NO >> GO TO 20.

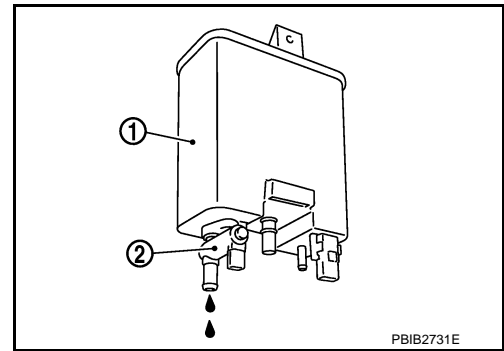

## 18. CHECK EVAP CANISTER

Weigh the EVAP canister with the EVAP canister vent control valve and EVAP control system pressure sensor attached.

**The weight should be less than 2.1 kg (4.6 lb).**

### Is the inspection result normal?

- YES >> GO TO 20.
- NO >> GO TO 19.

## 19. DETECT MALFUNCTIONING PART

Check the following.

- EVAP canister for damage
- EVAP hose between EVAP canister and vehicle frame for clogging or poor connection

>> Repair hose or replace EVAP canister.

## 20. CHECK INTERMITTENT INCIDENT

Refer to [GI-44, "Intermittent Incident"](#).

>> INSPECTION END

## Component Inspection

INFOID:000000006882994

## 1. CHECK EVAP CONTROL SYSTEM PRESSURE SENSOR

1. Turn ignition switch OFF.
2. Remove EVAP control system pressure sensor with its harness connector.  
**Always replace O-ring with a new one.**
3. Install a vacuum pump to EVAP control system pressure sensor.
4. Turn ignition switch ON and check output voltage between ECM harness connector terminals under the following conditions.

| Connector | ECM      |          | Condition<br>[Applied vacuum kPa (kg/cm <sup>2</sup> , psi)] | Voltage (V)                       |
|-----------|----------|----------|--|-----------------------------------|
|           | +        | -        |  |                                   |
|           | Terminal | Terminal |  |                                   |
| M107      | 102      | 112      | Not applied  | 1.8 - 4.8                         |
|           |          |          | -26.7 (-0.272, -3.87)  | 2.1 to 2.5 lower than above value |

### **CAUTION:**

- **Always calibrate the vacuum pump gauge when using it.**
- **Do not apply below -93.3 kPa (-0.952 kg/cm<sup>2</sup>, -13.53 psi) or pressure over 101.3 kPa (1.033 kg/cm<sup>2</sup>, 14.69 psi).**

### Is the inspection result normal?

- YES >> INSPECTION END
- NO >> Replace EVAP control system pressure sensor. Refer to [FL-13, "Exploded View"](#).

# P0456 EVAP CONTROL SYSTEM

< DTC/CIRCUIT DIAGNOSIS >

[VQ37VHR FOR USA AND CANADA]

## P0456 EVAP CONTROL SYSTEM

### DTC Logic

INFOID:000000006882995

### DTC DETECTION LOGIC

This diagnosis detects leaks in the EVAP line between fuel tank and EVAP canister purge volume control solenoid valve, using the negative pressure caused by decrease of fuel temperature in the fuel tank after turning ignition switch OFF.

If ECM judges that there are no leaks, the diagnosis will be OK.

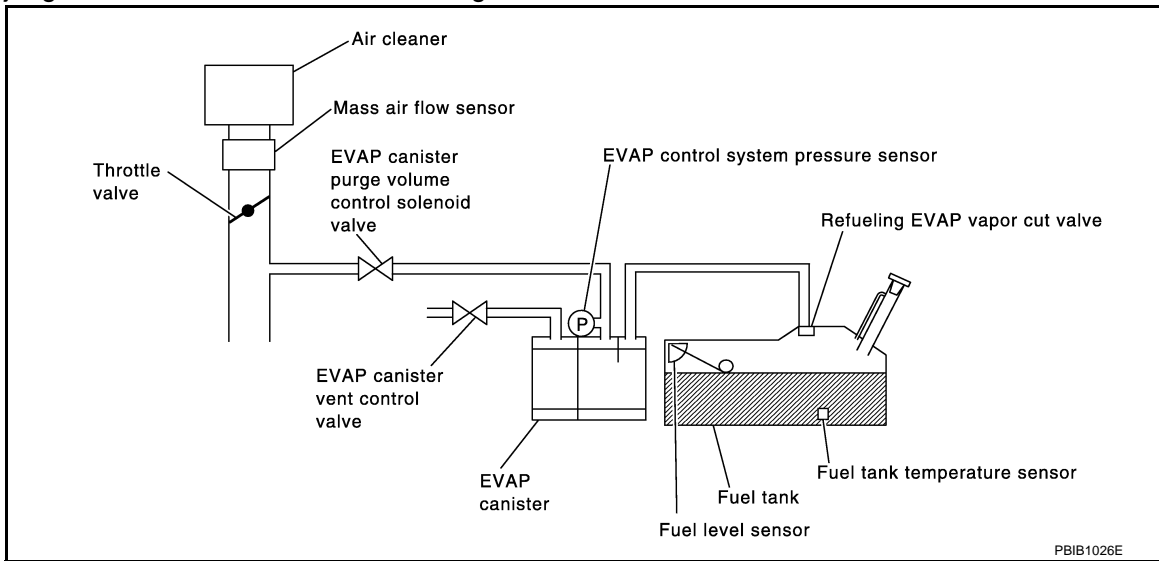

| DTC No. | Trouble diagnosis name  | DTC detecting condition  | Possible cause  |
|---------|---|--|---|
| P0456   | Evaporative emission control system very small leak (negative pressure check) | <ul style="list-style-type: none"> <li>• EVAP system has a very small leak.</li> <li>• EVAP system does not operate properly.</li> </ul> | <ul style="list-style-type: none"> <li>• Incorrect fuel tank vacuum relief valve</li> <li>• Incorrect fuel filler cap used</li> <li>• Fuel filler cap remains open or fails to close.</li> <li>• Foreign matter caught in fuel filler cap.</li> <li>• Leak is in line between intake manifold and EVAP canister purge volume control solenoid valve.</li> <li>• Foreign matter caught in EVAP canister vent control valve.</li> <li>• EVAP canister or fuel tank leaks</li> <li>• EVAP purge line (pipe and rubber tube) leaks</li> <li>• EVAP purge line rubber tube bent</li> <li>• Loose or disconnected rubber tube</li> <li>• EVAP canister vent control valve and the circuit</li> <li>• EVAP canister purge volume control solenoid valve and the circuit</li> <li>• Fuel tank temperature sensor</li> <li>• O-ring of EVAP canister vent control valve is missing or damaged</li> <li>• EVAP canister is saturated with water</li> <li>• EVAP control system pressure sensor</li> <li>• Refueling EVAP vapor cut valve</li> <li>• ORVR system leaks</li> <li>• Fuel level sensor and the circuit</li> <li>• Foreign matter caught in EVAP canister purge volume control solenoid valve</li> </ul> |

### CAUTION:

- Use only a genuine NISSAN fuel filler cap as a replacement. If an incorrect fuel filler cap is used, the MIL may illuminate.
- If the fuel filler cap is not tightened properly, the MIL may illuminate.
- Use only a genuine NISSAN rubber tube as a replacement.

### DTC CONFIRMATION PROCEDURE

#### 1. PRECONDITIONING



# P0456 EVAP CONTROL SYSTEM

[VQ37VHR FOR USA AND CANADA]

## < DTC/CIRCUIT DIAGNOSIS >

If DTC Confirmation Procedure has been previously conducted, always perform the following before conducting the next test.

1. Turn ignition switch OFF and wait at least 10 seconds.
2. Turn ignition switch ON.
3. Turn ignition switch OFF and wait at least 10 seconds.

### Do you have CONSULT?

YES >> GO TO 2.

NO >> GO TO 4.

## 2.PERFORM DTC CONFIRMATION PROCEDURE-I

### With CONSULT

1. Turn ignition switch ON and select "EVAP DIAG READY" in "DATA MONITOR" mode with CONSULT.
2. Start engine and wait at idle until "OFF" of "EVAP DIAG READY" changes to "ON".

#### **NOTE:**

It will take at most 2 hours until "OFF" of "EVAP DIAG READY" changes to "ON".

3. Turn ignition switch OFF and wait at least 90 minutes.

#### **NOTE:**

Never turn ignition switch ON during 90 minutes.

4. Turn ignition switch ON and select "EVAP LEAK DIAG" in "DATA MONITOR" mode with CONSULT.
5. Check that "EVAP LEAK DIAG" indication.

### Which is displayed on CONSULT?

CMPLT >> GO TO 3.

YET >> Perform DTC CONFIRMATION PROCEDURE again. GO TO 1.

## 3.PERFORM COMPONENT FUNCTION CHECK-II

Check 1st trip DTC.

### Is 1st trip DTC detected?

YES >> Go to [EC-361, "Diagnosis Procedure"](#).

NO >> INSPECTION END

## 4.PERFORM DTC CONFIRMATION PROCEDURE

### With GST

1. Start engine and wait engine idle for at least 2 hours.
2. Turn ignition switch OFF and wait at least 90 minutes.

#### **NOTE:**

Never turn ignition switch ON during 90 minutes.

3. Turn ignition switch ON.
4. Check 1st trip DTC.

### Is 1st trip DTC detected?

YES >> Go to [EC-361, "Diagnosis Procedure"](#).

NO >> INSPECTION END

## Diagnosis Procedure

INFOID:000000006882996

### 1.CHECK FUEL FILLER CAP DESIGN

1. Turn ignition switch OFF.
2. Check for genuine NISSAN fuel filler cap design.

### Is the inspection result normal?

YES >> GO TO 2.

NO >> Replace with genuine NISSAN fuel filler cap.

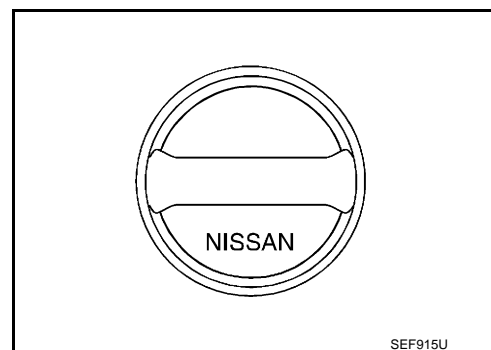

## P0456 EVAP CONTROL SYSTEM

< DTC/CIRCUIT DIAGNOSIS >

[VQ37VHR FOR USA AND CANADA]

### 2. CHECK FUEL FILLER CAP INSTALLATION

Check that the cap is tightened properly by rotating the cap clockwise.

Is the inspection result normal?

YES >> GO TO 3.

NO >> Open fuel filler cap, then clean cap and fuel filler neck threads using air blower. Then retighten until ratcheting sound is heard.

### 3. CHECK FUEL FILLER CAP FUNCTION

Check for air releasing sound while opening the fuel filler cap.

Is the inspection result normal?

YES >> GO TO 5.

NO >> GO TO 4.

### 4. CHECK FUEL TANK VACUUM RELIEF VALVE

Refer to [EC-527, "Component Inspection"](#).

Is the inspection result normal?

YES >> GO TO 5.

NO >> Replace fuel filler cap with a genuine one.

### 5. CHECK FOR EVAP LEAK

Refer to [EC-540, "Inspection"](#).

Is there any leak in EVAP line?

YES >> Repair or replace.

NO >> GO TO 6.

### 6. CHECK EVAP CANISTER VENT CONTROL VALVE

Check the following.

- EVAP canister vent control valve is installed properly.

Refer to [FL-13, "Exploded View"](#).

- EVAP canister vent control valve.

Refer to [EC-340, "Component Inspection"](#).

Is the inspection result normal?

YES >> GO TO 7.

NO >> Repair or replace EVAP canister vent control valve and O-ring.

### 7. CHECK IF EVAP CANISTER IS SATURATED WITH WATER

1. Remove EVAP canister (1) with EVAP canister vent control valve (2) and EVAP control system pressure sensor attached.
2. Check if water will drain from EVAP canister.

Does water drain from the EVAP canister?

YES >> GO TO 8.

NO-1 >> With CONSULT: GO TO 10.

NO-2 >> Without CONSULT: GO TO 11.

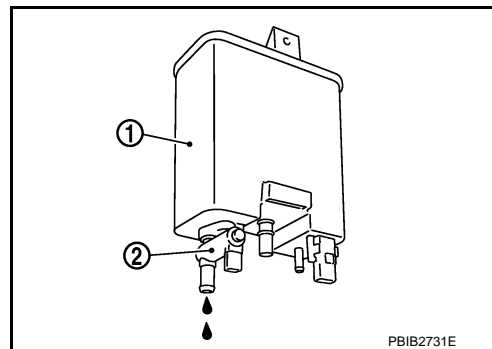

PBIB2731E

### 8. CHECK EVAP CANISTER

Weigh the EVAP canister assembly with the EVAP canister vent control valve and EVAP control system pressure sensor attached.

**The weight should be less than 2.1 kg (4.6 lb).**

Is the inspection result normal?

YES-1 >> With CONSULT: GO TO 10.

YES-2 >> Without CONSULT: GO TO 11.

NO >> GO TO 9.

# P0456 EVAP CONTROL SYSTEM

< DTC/CIRCUIT DIAGNOSIS >

[VQ37VHR FOR USA AND CANADA]

## 9. DETECT MALFUNCTIONING PART

Check the following.

- EVAP canister for damage
- EVAP hose between EVAP canister and vehicle frame for clogging or poor connection

>> Repair hose or replace EVAP canister.

## 10. CHECK EVAP CANISTER PURGE VOLUME CONTROL SOLENOID VALVE OPERATION

### With CONSULT

1. Disconnect vacuum hose connected to EVAP service port and EVAP canister purge volume control solenoid valve from EVAP service port.
2. Start engine and let it idle.
3. Select "PURG VOL CONT/V" in "ACTIVE TEST" mode.
4. Touch "Qu" on CONSULT screen to increase "PURG VOL C/V" opening to 100%.
5. Check vacuum hose for vacuum.

**Vacuum should exist.**

Is the inspection result normal?

- YES >> GO TO 13.  
NO >> GO TO 12.

## 11. CHECK EVAP CANISTER PURGE VOLUME CONTROL SOLENOID VALVE OPERATION

### Without CONSULT

1. Start engine and warm it up to normal operating temperature.
2. Stop engine.
3. Disconnect vacuum hose connected to EVAP service port and EVAP canister purge volume control solenoid valve from EVAP service port.
4. Start engine and let it idle for at least 80 seconds.
5. Check vacuum hose for vacuum when revving engine up to 2,000 rpm.

**Vacuum should exist.**

Is the inspection result normal?

- YES >> GO TO 13.  
NO >> GO TO 12.

## 12. CHECK VACUUM HOSE

Check vacuum hoses for clogging or disconnection. Refer to [EC-65, "EVAPORATIVE EMISSION SYSTEM: System Description"](#).

Is the inspection result normal?

- YES >> GO TO 13.  
NO >> Repair or reconnect the hose.

## 13. CHECK EVAP CANISTER PURGE VOLUME CONTROL SOLENOID VALVE

Refer to [EC-334, "Component Inspection"](#).

Is the inspection result normal?

- YES >> GO TO 14.  
NO >> Replace EVAP canister purge volume control solenoid valve. Refer to [EM-31, "Exploded View"](#).

## 14. CHECK FUEL TANK TEMPERATURE SENSOR

Refer to [EC-290, "Component Inspection"](#).

Is the inspection result normal?

- YES >> GO TO 15.  
NO >> Replace fuel level sensor unit.

## 15. CHECK EVAP CONTROL SYSTEM PRESSURE SENSOR

Refer to [EC-349, "Component Inspection"](#).

## P0456 EVAP CONTROL SYSTEM

[VQ37VHR FOR USA AND CANADA]

< DTC/CIRCUIT DIAGNOSIS >

Is the inspection result normal?

YES >> GO TO 16.

NO >> Replace EVAP control system pressure sensor. Refer to [FL-13, "Exploded View"](#).

### 16.CHECK EVAP PURGE LINE

Check EVAP purge line (pipe, rubber tube, fuel tank and EVAP canister) for cracks or improper connection. Refer to [EC-65, "EVAPORATIVE EMISSION SYSTEM : System Description"](#).

Is the inspection result normal?

YES >> GO TO 17.

NO >> Repair or reconnect the hose.

### 17.CLEAN EVAP PURGE LINE

Clean EVAP purge line (pipe and rubber tube) using air blower.

>> GO TO 18.

### 18.CHECK EVAP/ORVR LINE

Check EVAP/ORVR line between EVAP canister and fuel tank for clogging, kinks, looseness and improper connection. For location, refer to [EC-525, "Diagnosis Procedure"](#).

Is the inspection result normal?

YES >> GO TO 19.

NO >> Repair or replace hoses and tubes.

### 19.CHECK RECIRCULATION LINE

Check recirculation line between filler neck tube and fuel tank for clogging, kinks, cracks, looseness and improper connection.

Is the inspection result normal?

YES >> GO TO 20.

NO >> Repair or replace hose, tube or filler tube.

### 20.CHECK REFUELING EVAP VAPOR CUT VALVE

Refer to [EC-527, "Component Inspection"](#).

Is the inspection result normal?

YES >> GO TO 21.

NO >> Replace refueling EVAP vapor cut valve with fuel tank. Refer to [FL-10, "Exploded View"](#).

### 21.CHECK FUEL LEVEL SENSOR

Refer to [MWI-63, "Component Inspection"](#).

Is the inspection result normal?

YES >> GO TO 22.

NO >> Replace fuel level sensor unit. Refer to [FL-5, "Exploded View"](#).

### 22.CHECK INTERMITTENT INCIDENT

Refer to [GI-44, "Intermittent Incident"](#).

>> INSPECTION END

## Component Inspection

INFOID:000000006882997

### 1.CHECK FUEL TANK VACUUM RELIEF VALVE

1. Turn ignition switch OFF.
2. Remove fuel filler cap.

# P0456 EVAP CONTROL SYSTEM

[VQ37VHR FOR USA AND CANADA]

< DTC/CIRCUIT DIAGNOSIS >

3. Wipe clean valve housing.

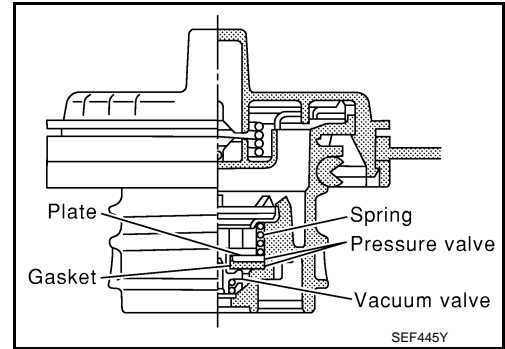

4. Check valve opening pressure and vacuum.

**Pressure:** 15.3 - 20.0 kPa (0.156 - 0.204 kg/cm<sup>2</sup>, 2.22 - 2.90 psi)

**Vacuum:** -6.0 to -3.3 kPa (-0.061 to -0.034 kg/cm<sup>2</sup>, -0.87 to -0.48 psi)

Is the inspection result normal?

YES >> INSPECTION END

NO >> GO TO 2.

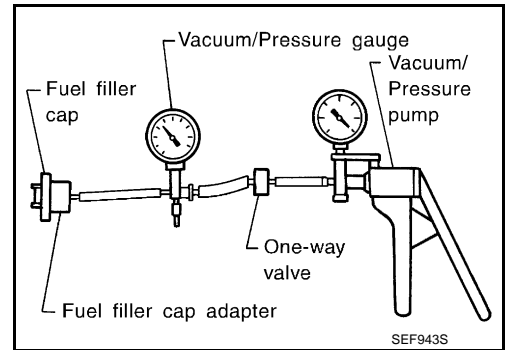

## 2. REPLACE FUEL FILLER CAP

Replace fuel filler cap.

### **CAUTION:**

**Use only a genuine fuel filler cap as a replacement. If an incorrect fuel filler cap is used, the MIL may illuminate.**

>> INSPECTION END

# P0460 FUEL LEVEL SENSOR

< DTC/CIRCUIT DIAGNOSIS >

[VQ37VHR FOR USA AND CANADA]

## P0460 FUEL LEVEL SENSOR

### DTC Logic

INFOID:000000006882998

#### DTC DETECTION LOGIC

##### NOTE:

- If DTC P0460 is displayed with DTC UXXXX, first perform the trouble diagnosis for DTC UXXXX.
- If DTC P0460 is displayed with DTC P0607, first perform the trouble diagnosis for DTC P0607. Refer to [EC-387, "DTC Logic"](#).

When the vehicle is parked, the fuel level in the fuel tank is naturally stable. It means that output signal of the fuel level sensor does not change. If ECM senses sloshing signal from the sensor, fuel level sensor malfunction is detected.

| DTC No. | Trouble diagnosis name          | DTC detecting condition   | Possible cause  |
|---------|---------------------------------|---|---|
| P0460   | Fuel level sensor circuit noise | Even though the vehicle is parked, a signal being varied is sent from the fuel level sensor to ECM. | <ul style="list-style-type: none"><li>• Harness or connectors (The CAN communication line is open or shorted)</li><li>• Harness or connectors (The sensor circuit is open or shorted)</li><li>• Combination meter</li><li>• Fuel level sensor</li></ul> |

#### DTC CONFIRMATION PROCEDURE

##### 1. PRECONDITIONING

If DTC Confirmation Procedure has been previously conducted, always perform the following procedure before conducting the next test.

1. Turn ignition switch OFF and wait at least 10 seconds.
2. Turn ignition switch ON.
3. Turn ignition switch OFF and wait at least 10 seconds.

>> GO TO 2.

##### 2. PERFORM DTC CONFIRMATION PROCEDURE

1. Start engine and wait maximum of 2 consecutive minutes.
2. Check 1st trip DTC.

Is 1st trip DTC detected?

- YES >> Go to [EC-366, "Diagnosis Procedure"](#).  
NO >> INSPECTION END

#### Diagnosis Procedure

INFOID:000000006882999

##### 1. CHECK DTC WITH "COMBINATION METER"

Refer to [MWI-31, "CONSULT Function"](#).

Is the inspection result normal?

- YES >> GO TO 2.  
NO >> Go to [MWI-62, "Component Function Check"](#).

##### 2. CHECK INTERMITTENT INCIDENT

Refer to [GI-44, "Intermittent Incident"](#).

>> INSPECTION END

# P0461 FUEL LEVEL SENSOR

< DTC/CIRCUIT DIAGNOSIS >

[VQ37VHR FOR USA AND CANADA]

## P0461 FUEL LEVEL SENSOR

### DTC Logic

INFOID:000000006883000

#### DTC DETECTION LOGIC

##### NOTE:

- If DTC P0461 is displayed with DTC UXXXX, first perform the trouble diagnosis for DTC UXXXX.
- If DTC P0461 is displayed with DTC P0607, first perform the trouble diagnosis for DTC P0607. Refer to [EC-387, "DTC Logic"](#).

Driving long distances naturally affect fuel gauge level.

This diagnosis detects the fuel gauge malfunction of the gauge not moving even after a long distance has been driven.

| DTC No. | Trouble diagnosis name                      | DTC detecting condition  | Possible cause  |
|---------|---|--|---|
| P0461   | Fuel level sensor circuit range/performance | The output signal of the fuel level sensor does not change within the specified range even though the vehicle has been driven a long distance. | <ul style="list-style-type: none"><li>• Harness or connectors (The CAN communication line is open or shorted)</li><li>• Harness or connectors (The sensor circuit is open or shorted)</li><li>• Combination meter</li><li>• Fuel level sensor</li></ul> |

#### DTC CONFIRMATION PROCEDURE

### 1. PERFORM COMPONENT FUNCTION CHECK

Perform component function check. Refer to [EC-367, "Component Function Check"](#).

Use component function check to check the overall function of the fuel level sensor. During this check, a 1st trip DTC might not be confirmed.

Is the inspection result normal?

YES >> INSPECTION END

NO >> Go to [EC-368, "Diagnosis Procedure"](#).

### Component Function Check

INFOID:000000006883001

### 1. PRECONDITIONING

#### WARNING:

When performing the following procedure, always observe the handling of the fuel. Refer to [FL-6, "Removal and Installation"](#).

#### TESTING CONDITION:

Before starting component function check, preparation of draining fuel and refilling fuel is required.

Do you have CONSULT?

YES >> GO TO 2.

NO >> GO TO 3.

### 2. PERFORM COMPONENT FUNCTION CHECK

#### Ⓜ With CONSULT

##### NOTE:

Start from step 10, if it is possible to confirm that the fuel cannot be drained by 30 ℓ (7-7/8 US gal, 6-5/8 Imp gal) in advance.

1. Prepare a fuel container and a spare hose.
2. Release fuel pressure from fuel line, refer to [EC-158, "Work Procedure"](#).
3. Remove the fuel feed hose on the fuel level sensor unit.
4. Connect a spare fuel hose where the fuel feed hose was removed.
5. Turn ignition switch OFF and wait at least 10 seconds then turn ON.
6. Select "FUEL LEVEL SE" in "DATA MONITOR" mode with CONSULT.
7. Check "FUEL LEVEL SE" output voltage and note it.
8. Select "FUEL PUMP RELAY" in "ACTIVE TEST" mode with CONSULT.
9. Touch "ON" and drain fuel approximately 30 ℓ (7-7/8 US gal, 6-5/8 Imp gal) and stop it.

# P0461 FUEL LEVEL SENSOR

[VQ37VHR FOR USA AND CANADA]

< DTC/CIRCUIT DIAGNOSIS >

10. Check "FUEL LEVEL SE" output voltage and note it.
11. Fill fuel into the fuel tank for 30 ℓ (7-7/8 US gal, 6-5/8 Imp gal).
12. Check "FUEL LEVEL SE" output voltage and note it.
13. Confirm whether the voltage changes more than 0.03V during step 7 to 10 and 10 to 12.

Is the inspection result normal?

- YES >> INSPECTION END  
NO >> Go to [EC-368, "Diagnosis Procedure"](#).

## 3.PERFORM COMPONENT FUNCTION CHECK

⊗ Without CONSULT

**NOTE:**

**Start from step 8, if it is possible to confirm that the fuel cannot be drained by 30 ℓ (7-7/8 US gal, 6-5/8 Imp gal) in advance.**

1. Prepare a fuel container and a spare hose.
2. Release fuel pressure from fuel line. Refer to [EC-158, "Work Procedure"](#).
3. Remove the fuel feed hose on the fuel level sensor unit.
4. Connect a spare fuel hose where the fuel feed hose was removed.
5. Turn ignition switch ON.
6. Drain fuel by 30 ℓ (7-7/8 US gal, 6-5/8 Imp gal) from the fuel tank using proper equipment.
7. Confirm that the fuel gauge indication varies.
8. Fill fuel into the fuel tank for 30 ℓ (7-7/8 US gal, 6-5/8 Imp gal).
9. Confirm that the fuel gauge indication varies.

Is the inspection result normal?

- YES >> INSPECTION END  
NO >> Go to [EC-368, "Diagnosis Procedure"](#).

## Diagnosis Procedure

INFOID:000000006883002

### 1.CHECK DTC WITH "COMBINATION METER"

Refer to [MWI-31, "CONSULT Function"](#).

Is the inspection result normal?

- YES >> GO TO 2.  
NO >> Go to [MWI-62, "Component Function Check"](#).

### 2.CHECK INTERMITTENT INCIDENT

Refer to [GI-44, "Intermittent Incident"](#).

>> INSPECTION END



# P0462, P0463 FUEL LEVEL SENSOR

< DTC/CIRCUIT DIAGNOSIS >

[VQ37VHR FOR USA AND CANADA]

## P0462, P0463 FUEL LEVEL SENSOR

### DTC Logic

INFOID:000000006883003

### DTC DETECTION LOGIC

#### NOTE:

- If DTC P0462 or P0463 is displayed with DTC UXXXX, first perform the trouble diagnosis for DTC UXXXX.
- If DTC P0462 or P0463 is displayed with DTC P0607, first perform the trouble diagnosis for DTC P0607. Refer to [EC-387, "DTC Logic"](#).

| DTC No. | Trouble diagnosis name               | DTC detecting condition                                     | Possible cause  |
|---------|--------------------------------------|---|---|
| P0462   | Fuel level sensor circuit low input  | An excessively low voltage from the sensor is sent to ECM.  | <ul style="list-style-type: none"><li>• Harness or connectors (The CAN communication line is open or shorted)</li></ul>   |
| P0463   | Fuel level sensor circuit high input | An excessively high voltage from the sensor is sent to ECM. | <ul style="list-style-type: none"><li>• Harness or connectors (The sensor circuit is open or shorted)</li><li>• Combination meter</li><li>• Fuel level sensor</li></ul> |

### DTC CONFIRMATION PROCEDURE

#### 1. PRECONDITIONING

If DTC Confirmation Procedure has been previously conducted, always perform the following procedure before conducting the next test.

1. Turn ignition switch OFF and wait at least 10 seconds.
2. Turn ignition switch ON.
3. Turn ignition switch OFF and wait at least 10 seconds.

#### TESTING CONDITION:

Before performing the following procedure, confirm that battery voltage is more than 11 V at ignition switch ON.

>> GO TO 2.

#### 2. PERFORM DTC CONFIRMATION PROCEDURE

1. Turn ignition switch ON and wait at least 5 seconds.
2. Check 1st trip DTC.

Is 1st trip DTC detected?

YES >> Go to [EC-369, "Diagnosis Procedure"](#).

NO >> INSPECTION END

### Diagnosis Procedure

INFOID:000000006883004

#### 1. CHECK DTC WITH "COMBINATION METER"

Refer to [MWI-31, "CONSULT Function"](#).

Is the inspection result normal?

YES >> GO TO 2.

NO >> Go to [MWI-62, "Component Function Check"](#).

#### 2. CHECK INTERMITTENT INCIDENT

Refer to [GI-44, "Intermittent Incident"](#).

>> INSPECTION END

## P0500 VSS

### Description

INFOID:000000006883005

The vehicle speed signal is sent to the “combination meter” from the “ABS actuator and electric unit (control unit)” via the CAN communication line. The “combination meter” then sends a signal to the ECM via the CAN communication line.

### DTC Logic

INFOID:000000006883006

#### DTC DETECTION LOGIC

**NOTE:**

- If DTC P0500 is displayed with DTC UXXXX, first perform the trouble diagnosis for DTC UXXXX.
- If DTC P0500 is displayed with DTC P0607, first perform the trouble diagnosis for DTC P0607. Refer to [EC-387, "DTC Logic"](#).

| DTC No. | Trouble diagnosis name | DTC detecting condition  | Possible cause   |
|---------|------------------------|--|--|
| P0500   | Vehicle speed sensor   | The vehicle speed signal sent to ECM is almost 0 km/h (0 MPH) even when vehicle is being driven. | <ul style="list-style-type: none"> <li>• Harness or connectors (The CAN communication line is open or shorted)</li> <li>• Harness or connectors (The vehicle speed signal circuit is open or shorted)</li> <li>• Wheel sensor</li> <li>• Combination meter</li> <li>• ABS actuator and electric unit (control unit)</li> </ul> |

#### DTC CONFIRMATION PROCEDURE

##### 1.INSPECTION START

Do you have CONSULT?

Do you have CONSULT?

- YES >> GO TO 2.  
 NO >> GO TO 5.

##### 2.PRECONDITIONING

If DTC Confirmation Procedure has been previously conducted, always perform the following procedure before conducting the next test.

1. Turn ignition switch OFF and wait at least 10 seconds.
2. Turn ignition switch ON.
3. Turn ignition switch OFF and wait at least 10 seconds.

>> GO TO 3.

##### 3.CHECK VEHICLE SPEED SIGNAL

**NOTE:**

**This procedure may be conducted with the drive wheels lifted in the shop or by driving the vehicle. If a road test is expected to be easier, it is unnecessary to lift the vehicle.**

**Ⓢ With CONSULT**

1. Start engine (VDC switch OFF).
2. Read “VHCL SPEED SE” in “DATA MONITOR” mode with CONSULT. The vehicle speed on CONSULT should exceed 10 km/h (6 MPH) when rotating wheels with suitable gear position.

Is the inspection result normal?

- YES >> GO TO 4.  
 NO >> Go to [EC-371, "Diagnosis Procedure"](#).

##### 4.PERFORM DTC CONFIRMATION PROCEDURE

1. Select “DATA MONITOR” mode with CONSULT.
2. Warm engine up to normal operating temperature.
3. Maintain the following conditions for at least 50 consecutive seconds.

**CAUTION:**

**Always drive vehicle at a safe speed.**

|                |                        |
|----------------|------------------------|
| ENG SPEED      | 1,500 - 6,000 rpm      |
| COOLAN TEMP/S  | More than 70°C (158°F) |
| B/FUEL SCHDL   | 6.5 - 31.8 msec        |
| Selector lever | Except P or N position |
| PW/ST SIGNAL   | OFF                    |

4. Check 1st trip DTC.

Is 1st trip DTC detected?

YES >> Go to [EC-371, "Diagnosis Procedure"](#).

NO >> INSPECTION END

### 5.PERFORM COMPONENT FUNCTION CHECK

Perform component function check. Refer to [EC-371, "Component Function Check"](#).

Use component function check to check the overall function of the vehicle speed signal circuit. During this check, a 1st trip DTC might not be confirmed.

Is the inspection result normal?

YES >> INSPECTION END

NO >> Go to [EC-371, "Diagnosis Procedure"](#).

### Component Function Check

INFOID:000000006883007

### 1.PERFORM COMPONENT FUNCTION CHECK

#### With GST

1. Lift up drive wheels.

2. Start engine.

3. Read vehicle speed signal in Service \$01 with GST.

The vehicle speed signal on GST should be able to exceed 10 km/h (6 MPH) when rotating wheels with suitable gear position.

Is the inspection result normal?

YES >> INSPECTION END

NO >> Go to [EC-371, "Diagnosis Procedure"](#).

### Diagnosis Procedure

INFOID:000000006883008

### 1.CHECK DTC WITH “ABS ACTUATOR AND ELECTRIC UNIT (CONTROL UNIT)”

Refer to [BRC-40, "CONSULT Function"](#).

Is the inspection result normal?

YES >> GO TO 2.

NO >> Repair or replace.

### 2.CHECK DTC WITH “COMBINATION METER”

Refer to [MWI-31, "CONSULT Function"](#).

>> INSPECTION END

## P0506 ISC SYSTEM

### Description

INFOID:000000006883009

The ECM controls the engine idle speed to a specified level through the fine adjustment of the air, which is let into the intake manifold, by operating the electric throttle control actuator. The operating of the throttle valve is varied to allow for optimum control of the engine idling speed. The crankshaft position sensor (POS) detects the actual engine speed and sends a signal to the ECM.

The ECM controls the electric throttle control actuator so that the engine speed coincides with the target value memorized in the ECM. The target engine speed is the lowest speed at which the engine can operate steadily. The optimum value stored in the ECM is determined by taking into consideration various engine conditions, such as during warming up, deceleration and engine load (air conditioner, power steering and cooling fan operation, etc.).

### DTC Logic

INFOID:000000006883010

#### DTC DETECTION LOGIC

**NOTE:**

**If DTC P0506 is displayed with other DTC, first perform the trouble diagnosis for the other DTC.**

| DTC No. | Trouble diagnosis name                            | DTC detecting condition   | Possible cause  |
|---------|---|---|---|
| P0506   | Idle speed control system RPM lower than expected | The idle speed is less than the target idle speed by 100 rpm or more. | <ul style="list-style-type: none"> <li>• Electric throttle control actuator</li> <li>• Intake air leak</li> </ul> |

#### DTC CONFIRMATION PROCEDURE

##### 1. PRECONDITIONING

If DTC Confirmation Procedure has been previously conducted, always perform the following procedure before conducting the next test.

1. Turn ignition switch OFF and wait at least 10 seconds.
2. Turn ignition switch ON.
3. Turn ignition switch OFF and wait at least 10 seconds.

**If the idle speed is out of the specified value, perform [EC-149, "Work Procedure"](#), before conducting DTC Confirmation Procedure.**

**TESTING CONDITION:**

- Before performing the following procedure, confirm that battery voltage is more than 11 V at idle.
- Always perform the test at a temperature above -10°C(14°F).

>> GO TO 2.

##### 2. PERFORM DTC CONFIRMATION PROCEDURE

1. Start engine and warm it up to normal operating temperature.
2. Turn ignition switch OFF and wait at least 10 seconds.
3. Turn ignition switch ON.
4. Turn ignition switch OFF and wait at least 10 seconds.
5. Restart engine and run it for at least 1 minute at idle speed.
6. Check 1st trip DTC.

Is 1st trip DTC detected?

- YES >> Go to [EC-372, "Diagnosis Procedure"](#).  
 NO >> INSPECTION END

### Diagnosis Procedure

INFOID:000000006883011

##### 1. CHECK INTAKE AIR LEAK

1. Start engine and let it idle.
2. Listen for an intake air leak after the mass air flow sensor.

Is intake air leak detected?

- YES >> Discover air leak location and repair.

# P0506 ISC SYSTEM

[VQ37VHR FOR USA AND CANADA]

< DTC/CIRCUIT DIAGNOSIS >

NO >> GO TO 2.

## 2. REPLACE ECM

1. Stop engine.
2. Replace ECM.
3. Go to [EC-144, "Work Procedure"](#).

>> INSPECTION END

A

EC

C

D

E

F

G

H

I

J

K

L

M

N

O

P

## P0507 ISC SYSTEM

### Description

INFOID:000000006883012

The ECM controls the engine idle speed to a specified level through the fine adjustment of the air, which is let into the intake manifold, by operating the electric throttle control actuator. The operating of the throttle valve is varied to allow for optimum control of the engine idling speed. The crankshaft position sensor (POS) detects the actual engine speed and sends a signal to the ECM.

The ECM controls the electric throttle control actuator so that the engine speed coincides with the target value memorized in the ECM. The target engine speed is the lowest speed at which the engine can operate steadily. The optimum value stored in the ECM is determined by taking into consideration various engine conditions, such as during warming up, deceleration and engine load (air conditioner, power steering and cooling fan operation, etc.).

### DTC Logic

INFOID:000000006883013

### DTC DETECTION LOGIC

**NOTE:**

**If DTC P0507 is displayed with other DTC, first perform the trouble diagnosis for the other DTC.**

| DTC No. | Trouble diagnosis name                             | DTC detecting condition   | Possible cause  |
|---------|--|---|---|
| P0507   | Idle speed control system RPM higher than expected | The idle speed is more than the target idle speed by 200 rpm or more. | <ul style="list-style-type: none"> <li>• Electric throttle control actuator</li> <li>• Intake air leak</li> <li>• PCV system</li> </ul> |

### DTC CONFIRMATION PROCEDURE

#### 1. PRECONDITIONING

If DTC Confirmation Procedure has been previously conducted, always perform the following procedure before conducting the next test.

1. Turn ignition switch OFF and wait at least 10 seconds.
2. Turn ignition switch ON.
3. Turn ignition switch OFF and wait at least 10 seconds.

**If the idle speed is out of the specified value, perform [EC-149, "Work Procedure"](#), before conducting DTC Confirmation Procedure.**

**TESTING CONDITION:**

- Before performing the following procedure, confirm that battery voltage is more than 11 V at idle.
- Always perform the test at a temperature above -10°C(14°F).

>> GO TO 2.

#### 2. PERFORM DTC CONFIRMATION PROCEDURE

1. Start engine and warm it up to normal operating temperature.
2. Turn ignition switch OFF and wait at least 10 seconds.
3. Turn ignition switch ON.
4. Turn ignition switch OFF and wait at least 10 seconds.
5. Start engine and run it for at least 1 minute at idle speed.
6. Check 1st trip DTC.

Is 1st trip DTC detected?

- YES >> Go to [EC-374, "Diagnosis Procedure"](#).  
 NO >> INSPECTION END

### Diagnosis Procedure

INFOID:000000006883014

#### 1. CHECK PCV HOSE CONNECTION

Confirm that PCV hose is connected correctly.

Is the inspection result normal?

- YES >> GO TO 2.  
 NO >> Repair or replace.

# P0507 ISC SYSTEM

< DTC/CIRCUIT DIAGNOSIS >

[VQ37VHR FOR USA AND CANADA]

---

## 2.CHECK INTAKE AIR LEAK

---

1. Start engine and let it idle.
2. Listen for an intake air leak after the mass air flow sensor.

Is intake air leak detected?

- YES >> Discover air leak location and repair.  
NO >> GO TO 3.

---

## 3.REPLACE ECM

---

1. Stop engine.
2. Replace ECM.
3. Go to [EC-144, "Work Procedure"](#).

>> INSPECTION END

A

EC

C

D

E

F

G

H

I

J

K

L

M

N

O

P

# P050A, P050E COLD START CONTROL

< DTC/CIRCUIT DIAGNOSIS >

[VQ37VHR FOR USA AND CANADA]

## P050A, P050E COLD START CONTROL

### Description

INFOID:000000007202598

ECM controls ignition timing and engine idle speed when engine is started with pre-warming up condition. This control promotes the activation of three way catalyst by heating the catalyst and reduces emissions.

### DTC Logic

INFOID:000000007202599

### DTC DETECTION LOGIC

#### NOTE:

If DTC P050A or P050E is displayed with other DTC, first perform the trouble diagnosis for other DTC.

| DTC No. | Trouble diagnosis name                         | DTC detecting condition   | Possible cause  |
|---------|--|---|---|
| P050A   | Cold start idle air control system performance | ECM does not control engine idle speed properly when engine is started with pre-warming up condition.                                   | <ul style="list-style-type: none"><li>• Lack of intake air volume</li><li>• Fuel injection system</li><li>• ECM</li></ul> |
| P050E   | Cold start engine exhaust temperature too low  | The temperature of the catalyst inlet does not rise to the proper temperature when the engine is started with pre-warming up condition. |   |

### DTC CONFIRMATION PROCEDURE

#### 1. PRECONDITIONING

If DTC Confirmation Procedure has been previously conducted, always perform the following procedure before conducting the next test.

1. Turn ignition switch OFF and wait at least 10 seconds.
2. Turn ignition switch ON.
3. Turn ignition switch OFF and wait at least 10 seconds.

#### TESTING CONDITION:

Before performing the following procedure, confirm that battery voltage is more than 11 V at idle.

>> GO TO 2.

#### 2. PERFORM DTC CONFIRMATION PROCEDURE-I

##### With CONSULT

1. Turn ignition switch OFF and wait at least 10 seconds.
2. Turn ignition switch ON.
3. Select "DATA MONITOR" mode with CONSULT.
4. Check the indication of "COOLAN TEMP/S".

##### With GST

Follow the procedure "With CONSULT" above.

Is the value of "COOLAN TEMP/S" between 4°C (39°F) and 36°C (97°F)?

YES >> GO TO 3.

NO-1 [If it is below 4°C (39°F)]>>Warm up the engine until the value of "COOLAN TEMP/S" reaches 4°C (39°F) or more. Retry from step 1.

NO-2 [If it is above 36°C (97°F)]>>Cool engine down to less than 36°C (97°F). Retry from step 1.

#### 3. PERFORM DTC CONFIRMATION PROCEDURE-II

##### With CONSULT

1. Set the select lever in N range.
2. Start the engine and warm up in idle with the value of "COOLAN TEMP/S" between -10°C (14°F) and 40°C (104°F) for more than 15 seconds.
3. Check 1st trip DTC.

##### With GST

Follow the procedure "With CONSULT" above.

Is 1st trip DTC detected?

YES >> Go to [EC-377 "Diagnosis Procedure"](#).

NO >> INSPECTION END



# P050A, P050E COLD START CONTROL

[VQ37VHR FOR USA AND CANADA]

< DTC/CIRCUIT DIAGNOSIS >

INFOID:000000007202600

## Diagnosis Procedure

### 1. PERFORM IDLE AIR VOLUME LEARNING

Perform [EC-149, "Work Procedure"](#).

Is Idle Air Volume Learning carried out successfully?

YES >> GO TO 2.

NO >> Follow the instruction of Idle Air Volume Learning.

### 2. CHECK INTAKE SYSTEM

Check for the cause of intake air volume lacking. Refer to the following.

- Crushed intake air passage
- Intake air passage clogging
- Clogging of throttle body

Is the inspection result normal?

YES >> GO TO 3.

NO >> Repair or replace malfunctioning part

### 3. CHECK FUEL INJECTION SYSTEM FUNCTION

Perform DTC Confirmation Procedure for DTC P0171, P0174. Refer to [EC-279, "DTC Logic"](#).

Is the inspection result normal?

YES >> GO TO 4.

NO >> Go to [EC-280, "Diagnosis Procedure"](#) for DTC P0171, P0174.

### 4. PERFORM DTC CONFIRMATION PROCEDURE

1. Turn ignition switch ON.
2. Erase DTC.
3. Perform DTC Confirmation Procedure.  
See [EC-376, "DTC Logic"](#).

Is the 1st trip DTC P050A or P050E displayed again?

YES >> GO TO 5.

NO >> INSPECTION END

### 5. REPLACE ECM

1. Replace ECM.
2. Go to [EC-144, "Work Procedure"](#).

>> INSPECTION END

A

EC

C

D

E

F

G

H

I

J

K

L

M

N

O

P

# P0524 ENGINE OIL PRESSURE

< DTC/CIRCUIT DIAGNOSIS >

[VQ37VHR FOR USA AND CANADA]

## P0524 ENGINE OIL PRESSURE

### DTC Logic

INFOID:000000006883015

### DTC DETECTION LOGIC

#### NOTE:

If DTC P0524 is displayed with DTC P0075 or P0081, first perform the trouble diagnosis for DTC P0075, P0081. Refer to [EC-208, "DTC Logic"](#)

| DTC No. | Trouble diagnosis name      | Detecting condition  | Possible cause  |
|---------|-----------------------------|--|---|
| P0524   | Engine oil pressure too low | Engine oil pressure is low because there is a gap between angle of target and phase-control angle. | <ul style="list-style-type: none"><li>• Engine oil pressure or level too low</li><li>• Crankshaft position sensor (POS)</li><li>• Camshaft position sensor (PHASE)</li><li>• Intake valve control solenoid valve</li><li>• Accumulation of debris to the signal pick-up portion of the camshaft</li><li>• Timing chain installation</li><li>• Foreign matter caught in the oil groove for intake valve timing control</li></ul> |

### DTC CONFIRMATION PROCEDURE

#### 1. PRECONDITIONING-I

If DTC Confirmation Procedure has been previously conducted, always perform the following procedure before conducting the next test.

1. Turn ignition switch OFF and wait at least 10 seconds.
2. Turn ignition switch ON.
3. Turn ignition switch OFF and wait at least 10 seconds.

#### TESTING CONDITION:

Before performing the following procedure, confirm that battery voltage is between 10 V and 16 V at idle.

>> GO TO 2.

#### 2. PRECONDITIONING-II

Check oil level and oil pressure. Refer to [LU-7, "Inspection"](#).

Is the inspection result normal?

- YES >> GO TO 3.  
NO >> Go to [LU-7, "Inspection"](#).

#### 3. PERFORM DTC CONFIRMATION PROCEDURE

1. Select "DATA MONITOR" mode with CONSULT.
2. Maintain the following conditions for at least 20 consecutive seconds.

|                  |   |
|------------------|---|
| ENG SPEED        | More than 1,700 rpm   |
| COOLAN TEMP/S    | More than 70°C (158°F)  |
| Selector lever   | 1st or 2nd position   |
| Driving location | Driving vehicle uphill<br>(Increased engine load will help maintain the driving conditions required for this test.) |

#### CAUTION:

Always drive at a safe speed.

3. Check 1st trip DTC.

Is 1st trip DTC detected?

- YES >> Go to [EC-379, "Diagnosis Procedure"](#)  
NO >> INSPECTION END

# P0524 ENGINE OIL PRESSURE

[VQ37VHR FOR USA AND CANADA]

< DTC/CIRCUIT DIAGNOSIS >

INFOID:000000006883016

## Diagnosis Procedure

### 1. CHECK OIL PRESSURE WARNING LAMP

1. Start engine.
2. Check oil pressure warning lamp and confirm it is not illuminated.

Is oil pressure warning lamp illuminated?

- YES >> Go to [LU-7, "Inspection"](#).  
NO >> GO TO 2.

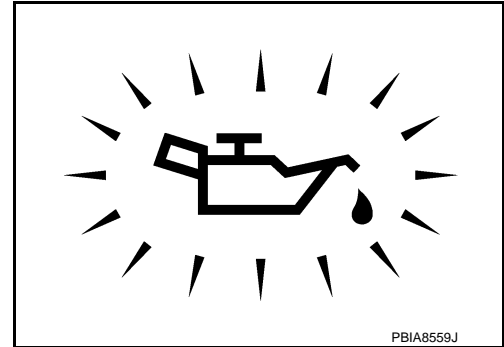

### 2. CHECK INTAKE VALVE TIMING CONTROL SOLENOID VALVE

Refer to [EC-193, "Component Inspection"](#).

Is the inspection result normal?

- YES >> GO TO 3.  
NO >> Replace malfunctioning intake valve timing control solenoid valve. Refer to [EM-52, "Exploded View"](#).

### 3. CHECK CRANKSHAFT POSITION SENSOR (POS)

Refer to [EC-314, "Component Inspection"](#).

Is the inspection result normal?

- YES >> GO TO 4.  
NO >> Replace crankshaft position sensor (POS). Refer to [EM-123, "Exploded View"](#).

### 4. CHECK CAMSHAFT POSITION SENSOR (PHASE)

Refer to [EC-319, "Component Inspection"](#).

Is the inspection result normal?

- YES >> GO TO 5.  
NO >> Replace malfunctioning camshaft position sensor (PHASE). Refer to [EM-52, "Exploded View"](#).

### 5. CHECK CAMSHAFT (INTAKE)

Check the following.

- Accumulation of debris to the signal plate of camshaft front end
- Chipping signal plate of camshaft front end

Is the inspection result normal?

- YES >> GO TO 6.  
NO >> Remove debris and clean the signal plate of camshaft front end or replace camshaft.

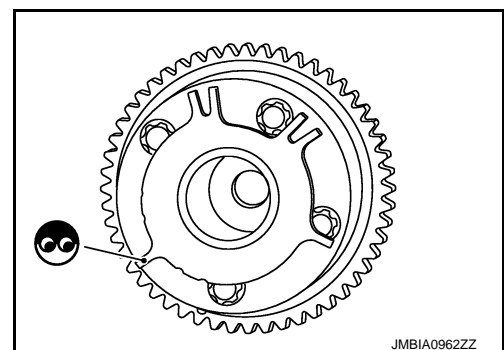

### 6. CHECK TIMING CHAIN INSTALLATION

Check service records for any recent repairs that may cause timing chain misaligned.

Are there any service records that may cause timing chain misaligned?

- YES >> Check timing chain installation. Refer to [EM-53, "Removal and Installation"](#).  
NO >> GO TO 7.

### 7. CHECK LUBRICATION CIRCUIT

Perform "Inspection of Camshaft Sprocket (INT) Oil Groove". Refer to [EM-106, "Inspection"](#).

# P0524 ENGINE OIL PRESSURE

[VQ37VHR FOR USA AND CANADA]

< DTC/CIRCUIT DIAGNOSIS >

Is the inspection result normal?

- YES >> GO TO 8.
- NO >> Clean lubrication line.

## 8.CHECK INTERMITTENT INCIDENT

Refer to [GI-44, "Intermittent Incident"](#).

>> INSPECTION END

## Component Inspection

INFOID:000000006883017

### 1.CHECK INTAKE VALVE TIMING CONTROL SOLENOID VALVE-I

1. Turn ignition switch OFF.
2. Disconnect intake valve timing control solenoid valve harness connector.
3. Check resistance between intake valve timing control solenoid valve terminals as per the following.

| Terminals         | Resistance ( $\Omega$ )                   |
|-------------------|---|
| 1 and 2           | 7.0 - 7.7 [at 20°C (68°F)]                |
| 1 or 2 and ground | $\infty$<br>(Continuity should not exist) |

Is the inspection result normal?

- YES >> GO TO 2.
- NO >> Replace malfunctioning intake valve timing control solenoid valve. Refer to [EM-52, "Exploded View"](#).

### 2.CHECK INTAKE VALVE TIMING CONTROL SOLENOID VALVE-II

1. Remove intake valve timing control solenoid valve.
2. Provide 12 V DC between intake valve timing control solenoid valve terminals 1 and 2, and then interrupt it. Make sure that the plunger moves as shown in the figure.

**CAUTION:**

**Never apply 12 V DC continuously for 5 seconds or more. Doing so may result in damage to the coil in intake valve timing control solenoid valve.**

**NOTE:**

**Always replace O-ring when intake valve timing control solenoid valve is removed.**

Is the inspection result normal?

- YES >> INSPECTION END
- NO >> Replace malfunctioning intake valve timing control solenoid valve. Refer to [EM-52, "Exploded View"](#).

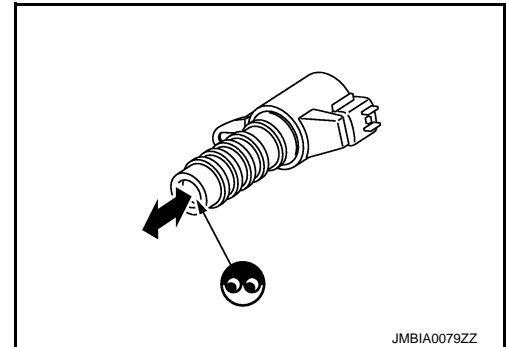

# P0550 PSP SENSOR

< DTC/CIRCUIT DIAGNOSIS >

[VQ37VHR FOR USA AND CANADA]

## P0550 PSP SENSOR

### DTC Logic

INFOID:000000006883018

### DTC DETECTION LOGIC

#### NOTE:

If DTC P0550 is displayed with DTC P0643, first perform the trouble diagnosis for DTC P0643. Refer to [EC-388, "DTC Logic"](#).

| DTC No. | Trouble diagnosis name                 | DTC detecting condition  | Possible cause   |
|---------|--|--|--|
| P0550   | Power steering pressure sensor circuit | An excessively low or high voltage from the sensor is sent to ECM. | <ul style="list-style-type: none"><li>• Harness or connectors (The sensor circuit is open or shorted)</li><li>• Power steering pressure sensor</li></ul> |

### DTC CONFIRMATION PROCEDURE

#### 1. PRECONDITIONING

If DTC Confirmation Procedure has been previously conducted, always perform the following procedure before conducting the next test.

1. Turn ignition switch OFF and wait at least 10 seconds.
2. Turn ignition switch ON.
3. Turn ignition switch OFF and wait at least 10 seconds.

>> GO TO 2.

#### 2. PERFORM DTC CONFIRMATION PROCEDURE

1. Start engine and let it idle for at least 5 seconds.
2. Check 1st trip DTC.

Is 1st trip DTC detected?

- YES >> Go to [EC-381, "Diagnosis Procedure"](#).  
NO >> INSPECTION END

### Diagnosis Procedure

INFOID:000000006883019

#### 1. CHECK GROUND CONNECTION

1. Turn ignition switch OFF.
2. Check ground connection M95. Refer to Ground Inspection in [GI-47, "Circuit Inspection"](#).

Is the inspection result normal?

- YES >> GO TO 2.  
NO >> Repair or replace ground connection.

#### 2. CHECK PSP SENSOR POWER SUPPLY CIRCUIT

1. Disconnect power steering pressure (PSP) sensor harness connector.
2. Turn ignition switch ON.
3. Check the voltage between PSP sensor harness connector and ground.

| PSP sensor |          | Ground | Voltage (V) |
|------------|----------|--------|-------------|
| Connector  | Terminal |        |             |
| F35        | 3        | Ground | Approx. 5   |

Is the inspection result normal?

- YES >> GO TO 3.  
NO >> Repair open circuit, short to ground or short to power in harness or connectors.

#### 3. CHECK PSP SENSOR GROUND CIRCUIT FOR OPEN AND SHORT

1. Turn ignition switch OFF.
2. Disconnect ECM harness connector.

# P0550 PSP SENSOR

[VQ37VHR FOR USA AND CANADA]

## < DTC/CIRCUIT DIAGNOSIS >

3. Check the continuity between PSP sensor harness connector and ECM harness connector.

| PSP sensor |          | ECM       |          | Continuity |
|------------|----------|-----------|----------|------------|
| Connector  | Terminal | Connector | Terminal |            |
| F35        | 1        | F102      | 96       | Existed    |

4. Also check harness for short to ground and short to power.

Is the inspection result normal?

YES >> GO TO 4.

NO >> Repair open circuit, short to ground short to power in harness or connectors.

## 4.CHECK PSP SENSOR INPUT SIGNAL CIRCUIT FOR OPEN AND SHORT

1. Check the continuity between PSP sensor harness connector and ECM harness connector.

| PSP sensor |          | ECM       |          | Continuity |
|------------|----------|-----------|----------|------------|
| Connector  | Terminal | Connector | Terminal |            |
| F35        | 2        | F102      | 87       | Existed    |

2. Also check harness for short to ground and short to power.

Is the inspection result normal?

YES >> GO TO 5.

NO >> Repair open circuit, short to ground or short to power in harness or connectors.

## 5.CHECK PSP SENSOR

Refer to [EC-382, "Component Inspection"](#).

Is the inspection result normal?

YES >> GO TO 6.

NO >> Replace PSP sensor. Refer to [ST-76, "2WD : Exploded View"](#).

## 6.CHECK INTERMITTENT INCIDENT

Refer to [GI-44, "Intermittent Incident"](#).

>> INSPECTION END

## Component Inspection

INFOID:000000006883020

## 1.CHECK POWER STEERING PRESSURE SENSOR

1. Turn ignition switch OFF.
2. Reconnect all harness connectors disconnected.
3. Start engine and let it idle.
4. Check the voltage between ECM harness connector terminals under the following conditions.

| ECM       |          |          | Condition      | Voltage (V)      |           |
|-----------|----------|----------|----------------|------------------|-----------|
| Connector | +        | -        |                |                  |           |
|           | Terminal | Terminal |                |                  |           |
| F102      | 87       | 96       | Steering wheel | Being turned     | 0.5 - 4.5 |
|           |          |          |                | Not being turned | 0.4 - 0.8 |

Is the inspection result normal?

YES >> INSPECTION END

NO >> Replace power steering pressure sensor. Refer to [ST-76, "2WD : Exploded View"](#).

# P0603 ECM POWER SUPPLY

< DTC/CIRCUIT DIAGNOSIS >

[VQ37VHR FOR USA AND CANADA]

## P0603 ECM POWER SUPPLY

### Description

INFOID:000000006883021

Battery voltage is supplied to the ECM even when the ignition switch is turned OFF for the ECM memory function of the DTC memory, the air-fuel ratio feedback compensation value memory, the idle air volume learning value memory, etc.

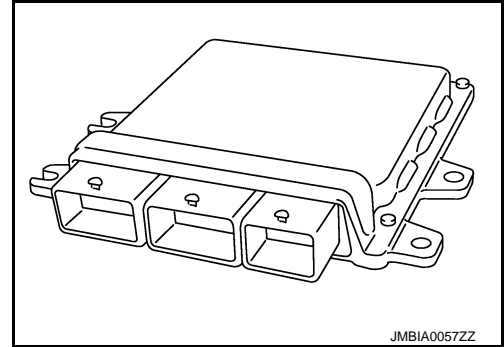

JMBIA0057ZZ

### DTC Logic

INFOID:000000006883022

#### DTC DETECTION LOGIC

| DTC No. | Trouble diagnosis name   | DTC detecting condition                            | Possible cause  |
|---------|--------------------------|--|---|
| P0603   | ECM power supply circuit | ECM back up RAM system does not function properly. | <ul style="list-style-type: none"> <li>• Harness or connectors [ECM power supply (back up) circuit is open or shorted.]</li> <li>• ECM</li> </ul> |

#### DTC CONFIRMATION PROCEDURE

##### 1. PRECONDITIONING

If DTC Confirmation Procedure has been previously conducted, always perform the following procedure before conducting the next test.

1. Turn ignition switch OFF and wait at least 10 seconds.
2. Turn ignition switch ON.
3. Turn ignition switch OFF and wait at least 10 seconds.

>> GO TO 2.

##### 2. PERFORM DTC CONFIRMATION PROCEDURE

1. Turn ignition switch ON and wait at least 10 seconds.
2. Turn ignition switch OFF and wait at least 5 minutes.
3. Turn ignition switch ON and wait at least 10 seconds.
4. Repeat steps 2 and 3 for five times.
5. Check 1st trip DTC.

Is 1st trip DTC detected?

- YES >> Go to [EC-383. "Diagnosis Procedure"](#).  
 NO >> INSPECTION END

### Diagnosis Procedure

INFOID:000000006883023

#### 1. CHECK ECM POWER SUPPLY

1. Turn ignition switch OFF.
2. Disconnect ECM harness connector.
3. Check the voltage between ECM harness connector terminals as per the following.

| ECM       |          |           |          | Voltage         |
|-----------|----------|-----------|----------|-----------------|
| +         |          | -         |          |                 |
| Connector | Terminal | Connector | Terminal |                 |
| F102      | 93       | M107      | 128      | Battery voltage |

## P0603 ECM POWER SUPPLY

[VQ37VHR FOR USA AND CANADA]

< DTC/CIRCUIT DIAGNOSIS >

Is the inspection result normal?

YES >> GO TO 3.

NO >> GO TO 2.

### 2. DETECT MALFUNCTIONING PART

---

Check the following.

- Harness connectors E20, F40
- 15 A fuse (No. 51)
- IPDM E/R harness connector E5
- Harness for open or short between ECM and battery

>> Repair or replace harness or connectors.

### 3. CHECK INTERMITTENT INCIDENT

---

Refer to [GI-44, "Intermittent Incident"](#).

Is the inspection result normal?

YES >> GO TO 4.

NO >> Repair or replace harness or connectors.

### 4. PERFORM DTC CONFIRMATION PROCEDURE

---

1. Turn ignition switch ON.
2. Erase DTC.
3. **Perform DTC Confirmation Procedure.**  
See [EC-383, "DTC Logic"](#).

Is the 1st trip DTC P0603 displayed again?

YES >> GO TO 5.

NO >> INSPECTION END

### 5. REPLACE ECM

---

1. Replace ECM.
2. Go to [EC-144, "Work Procedure"](#).

>> INSPECTION END



P0605 ECM

DTC Logic

INFOID:000000006883024

DTC DETECTION LOGIC

A  
EC

| DTC No. | Trouble diagnosis name | DTC detecting condition |   | Possible cause |
|---------|------------------------|-------------------------|---|----------------|
| P0605   | Engine control module  | A)                      | ECM calculation function is malfunctioning.   | • ECM          |
|         |                        | B)                      | ECM EEPROM system is malfunctioning.          |                |
|         |                        | C)                      | ECM self shut-off function is malfunctioning. |                |

C  
D

DTC CONFIRMATION PROCEDURE

1. PRECONDITIONING

If DTC Confirmation Procedure has been previously conducted, always perform the following procedure before conducting the next test.

1. Turn ignition switch OFF and wait at least 10 seconds.
2. Turn ignition switch ON.
3. Turn ignition switch OFF and wait at least 10 seconds.

E  
F

>> GO TO 2.

2. PERFORM DTC CONFIRMATION PROCEDURE FOR MALFUNCTION A

1. Turn ignition switch ON.
2. Check 1st trip DTC.

Is 1st trip DTC detected?

- YES >> Go to [EC-385, "Diagnosis Procedure"](#).
- NO >> GO TO 3.

G  
H

3. PERFORM DTC CONFIRMATION PROCEDURE FOR MALFUNCTION B

1. Turn ignition switch ON and wait at least 1 second.
2. Turn ignition switch OFF, wait at least 10 seconds, and then turn it ON.
3. Check 1st trip DTC.

Is 1st trip DTC detected?

- YES >> Go to [EC-385, "Diagnosis Procedure"](#).
- NO >> GO TO 4.

I  
J

4. PERFORM DTC CONFIRMATION PROCEDURE FOR MALFUNCTION C

1. Turn ignition switch ON and wait at least 1 second.
2. Turn ignition switch OFF, wait at least 10 seconds, and then turn it ON.
3. Repeat step 2 for 32 times.
4. Check 1st trip DTC.

Is 1st trip DTC detected?

- YES >> Go to [EC-385, "Diagnosis Procedure"](#).
- NO >> INSPECTION END

K  
L

Diagnosis Procedure

INFOID:000000006883025

1. INSPECTION START

1. Turn ignition switch ON.
2. Erase DTC.
3. Perform DTC Confirmation Procedure. See [EC-385, "DTC Logic"](#).

Is the 1st trip DTC P0605 displayed again?

- YES >> GO TO 2.
- NO >> INSPECTION END

M  
N

**2.**REPLACE ECM

---

1. Replace ECM.
2. Go to [EC-144, "Work Procedure"](#).

>> INSPECTION END

P0607 ECM

DTC Logic

INFOID:000000006883026

DTC DETECTION LOGIC

A  
EC

| DTC No. | Trouble diagnosis name | DTC detecting condition   | Possible cause  |
|---------|------------------------|---|---|
| P0607   | CAN communication bus  | When detecting error during the initial diagnosis of CAN controller of ECM. | <ul style="list-style-type: none"> <li>ECM</li> </ul> |

C

DTC CONFIRMATION PROCEDURE

1. PERFORM DTC CONFIRMATION PROCEDURE

1. Turn ignition switch ON.
2. Check DTC.

Is DTC detected?

- YES >> Go to [EC-387, "Diagnosis Procedure"](#).
- NO >> INSPECTION END

D

E

F

Diagnosis Procedure

INFOID:000000006883027

1. INSPECTION START

1. Turn ignition switch ON.
2. Erase DTC.
3. Perform DTC Confirmation Procedure.  
See [EC-387, "DTC Logic"](#).
4. Check DTC.

Is the DTC P0607 displayed again?

- YES >> GO TO 2.
- NO >> INSPECTION END

2. REPLACE ECM

1. Replace ECM.
2. Go to [EC-144, "Work Procedure"](#).

>> INSPECTION END

G

H

I

J

K

L

M

N

O

P

# P0643 SENSOR POWER SUPPLY

< DTC/CIRCUIT DIAGNOSIS >

[VQ37VHR FOR USA AND CANADA]

## P0643 SENSOR POWER SUPPLY

### DTC Logic

INFOID:000000006883028

### DTC DETECTION LOGIC

| DTC No. | Trouble diagnosis name            | DTC detecting condition   | Possible cause  |
|---------|-----------------------------------|---|---|
| P0643   | Sensor power supply circuit short | ECM detects that the voltage of power source for sensor is excessively low or high. | <ul style="list-style-type: none"><li>• Harness or connectors (APP sensor 1 circuit is shorted.) (TP sensor circuit is shorted.) [CMP sensor (PHASE) (bank 1) circuit is shorted.] [Manifold absolute pressure (MAP) sensor circuit is shorted.] (PSP sensor circuit is shorted.)</li><li>• Accelerator pedal position sensor</li><li>• Throttle position sensor</li><li>• Camshaft position sensor (PHASE) (bank 1)</li><li>• Manifold absolute pressure (MAP) sensor</li><li>• Power steering pressure sensor</li></ul> |

### DTC CONFIRMATION PROCEDURE

#### 1. PRECONDITIONING

If DTC Confirmation Procedure has been previously conducted, always perform the following procedure before conducting the next test.

1. Turn ignition switch OFF and wait at least 10 seconds.
2. Turn ignition switch ON.
3. Turn ignition switch OFF and wait at least 10 seconds.

#### TESTING CONDITION:

Before performing the following procedure, confirm that battery voltage is more than 10 V at idle.

>> GO TO 2.

#### 2. PERFORM DTC CONFIRMATION PROCEDURE

1. Start engine and let it idle for 1 second.
2. Check DTC.

#### Is DTC detected?

- YES >> Go to [EC-388, "Diagnosis Procedure"](#).  
NO >> INSPECTION END

### Diagnosis Procedure

INFOID:000000006883029

#### 1. CHECK GROUND CONNECTION

1. Turn ignition switch OFF.
2. Check ground connection M95. Refer to Ground Inspection in [GI-47, "Circuit Inspection"](#).

#### Is the inspection result normal?

- YES >> GO TO 2.  
NO >> Repair or replace ground connection.

#### 2. CHECK ACCELERATOR PEDAL POSITION SENSOR 1 POWER SUPPLY CIRCUIT

1. Disconnect accelerator pedal position (APP) sensor harness connector.
2. Turn ignition switch ON.
3. Check the voltage between APP sensor harness connector and ground.

| APP sensor |          | Ground | Voltage (V) |
|------------|----------|--------|-------------|
| Connector  | Terminal |        |             |
| M153*1     | 6*1      | Ground | Approx. 5   |
| M9*2       | 5*2      |        |             |

# P0643 SENSOR POWER SUPPLY

< DTC/CIRCUIT DIAGNOSIS >

[VQ37VHR FOR USA AND CANADA]

\*1: With ICC

\*2: Without ICC

Is the inspection result normal?

YES >> GO TO 7.

NO >> GO TO 3.

## 3.CHECK SENSOR POWER SUPPLY CIRCUITS

Check harness for short to power and short to ground, between the following terminals.

| ECM       |          | Sensor                                      |  |                                    |
|-----------|----------|---|--|------------------------------------|
| Connector | Terminal | Name  | Connector                              | Terminal                           |
| F101      | 43       | Electric throttle control actuator (bank 2) | F27                                    | 1                                  |
|           | 44       | Electric throttle control actuator (bank 1) | F67                                    | 6                                  |
| F102      | 60       | CMP sensor (PHASE) (bank 1)                 | F5                                     | 1                                  |
|           |          | Manifold absolute pressure (MAP) sensor     | F50                                    | 1                                  |
|           |          | PSP sensor                                  | F35                                    | 3                                  |
| M107      | 99       | APP sensor                                  | M153 <sup>*1</sup><br>M9 <sup>*2</sup> | 6 <sup>*1</sup><br>5 <sup>*2</sup> |

\*1: With ICC

\*2: Without ICC

Is the inspection result normal?

YES >> GO TO 4.

NO >> Repair short to ground or short to power in harness or connectors.

## 4.CHECK COMPONENTS

Check the following.

- Camshaft position sensor (PHASE) (bank 1) (Refer to [EC-319, "Component Inspection"](#).)
- Manifold absolute pressure (MAP) sensor (Refer to [EC-222, "Component Inspection"](#).)
- Power steering pressure sensor (Refer to [EC-382, "Component Inspection"](#).)

Is the inspection result normal?

YES >> GO TO 5.

NO >> Replace malfunctioning component.

## 5.CHECK TP SENSOR

Refer to [EC-235, "Component Inspection"](#).

Is the inspection result normal?

YES >> GO TO 9.

NO >> GO TO 6.

## 6.REPLACE ELECTRIC THROTTLE CONTROL ACTUATOR

1. Replace electric throttle control actuator.
2. Go to [EC-235, "Special Repair Requirement"](#).

>> INSPECTION END

## 7.CHECK APP SENSOR

Refer to [EC-487, "Component Inspection"](#).

Is the inspection result normal?

YES >> GO TO 9.

NO >> GO TO 8.

## 8.REPLACE ACCELERATOR PEDAL ASSEMBLY

1. Replace accelerator pedal assembly.
2. Go to [EC-487, "Special Repair Requirement"](#).

## P0643 SENSOR POWER SUPPLY

< DTC/CIRCUIT DIAGNOSIS >

[VQ37VHR FOR USA AND CANADA]

---

>> INSPECTION END

### 9. CHECK INTERMITTENT INCIDENT

---

Refer to [GI-44, "Intermittent Incident"](#).

>> INSPECTION END

# P0850 PNP SWITCH

< DTC/CIRCUIT DIAGNOSIS >

[VQ37VHR FOR USA AND CANADA]

## P0850 PNP SWITCH

### Description

INFOID:000000006883030

When the selector lever position is P or N, park/neutral position (PNP) signal from the TCM is sent to ECM. ECM detects the position because the continuity of the line (the ON signal) exists.

### DTC Logic

INFOID:000000006883031

### DTC DETECTION LOGIC

| DTC No. | Trouble diagnosis name       | DTC detecting condition  | Possible cause   |
|---------|------------------------------|--|--|
| P0850   | Park/neutral position switch | The signal of the park/neutral position (PNP) signal does not change during driving after the engine is started. | <ul style="list-style-type: none"><li>• Harness or connectors<br/>[The park/neutral position (PNP) signal circuit is open or shorted.]</li><li>• TCM</li></ul> |

### DTC CONFIRMATION PROCEDURE

#### 1.INSPECTION START

Do you have CONSULT?

Do you have CONSULT?

YES >> GO TO 2.

NO >> GO TO 5.

#### 2.PRECONDITIONING

If DTC Confirmation Procedure has been previously conducted, always perform the following procedure before conducting the next test.

1. Turn ignition switch OFF and wait at least 10 seconds.
2. Turn ignition switch ON.
3. Turn ignition switch OFF and wait at least 10 seconds.

>> GO TO 3.

#### 3.CHECK PNP SIGNAL

##### With CONSULT

1. Turn ignition switch ON.
2. Select "P/N POSI SW" in "DATA MONITOR" mode with CONSULT. Then check the "P/N POSI SW" signal under the following conditions.

| Position (Selector lever) | Known-good signal |
|---------------------------|-------------------|
| N or P position           | ON                |
| Except above position     | OFF               |

Is the inspection result normal?

YES >> GO TO 4.

NO >> Go to [EC-392. "Diagnosis Procedure"](#).

#### 4.PERFORM DTC CONFIRMATION PROCEDURE

1. Select "DATA MONITOR" mode with CONSULT.
2. Start engine and warm it up to normal operating temperature.
3. Maintain the following conditions for at least 50 consecutive seconds.

##### **CAUTION:**

**Always drive vehicle at a safe speed.**

|               |                        |
|---------------|------------------------|
| ENG SPEED     | 1,400 - 6,375 rpm      |
| COOLAN TEMP/S | More than 70°C (158°F) |

# P0850 PNP SWITCH

[VQ37VHR FOR USA AND CANADA]

## < DTC/CIRCUIT DIAGNOSIS >

|                |                            |
|----------------|----------------------------|
| B/FUEL SCHDL   | 2.0 - 31.8 msec            |
| VHCL SPEED SE  | More than 64 km/h (40 mph) |
| Selector lever | Suitable position          |

### 4. Check 1st trip DTC.

#### Is 1st trip DTC detected?

YES >> Go to [EC-392, "Diagnosis Procedure"](#).

NO >> INSPECTION END

## 5.PERFORM COMPONENT FUNCTION CHECK

Perform component function check. Refer to [EC-392, "Component Function Check"](#).

### NOTE:

Use component function check the overall function of the park/neutral position (PNP) signal circuit. During this check, a 1st trip DTC might not be confirmed.

#### Is the inspection result normal?

YES >> INSPECTION END

NO >> Go to [EC-392, "Diagnosis Procedure"](#).

## Component Function Check

INFOID:000000006883032

## 1.PERFORM COMPONENT FUNCTION CHECK

1. Turn ignition switch ON.
2. Check the voltage between ECM harness connector terminals under the following conditions.

| ECM       |          |          | Condition      | Voltage (V)  |                 |
|-----------|----------|----------|----------------|--------------|-----------------|
| Connector | +        | -        |                |              |                 |
|           | Terminal | Terminal |                |              |                 |
| M107      | 109      | 128      | Selector lever | P or N       | Battery voltage |
|           |          |          |                | Except above | Approx. 0       |

#### Is the inspection result normal?

YES >> INSPECTION END

NO >> Go to [EC-392, "Diagnosis Procedure"](#).

## Diagnosis Procedure

INFOID:000000006883033

## 1.CHECK DTC WITH TCM

Refer to [TM-59, "Diagnosis Description"](#).

#### Is the inspection result normal?

YES >> GO TO 2.

NO >> Repair or replace.

## 2.CHECK STARTING SYSTEM

Turn ignition switch OFF, then turn it to START.

#### Does starter motor operate?

YES >> GO TO 3.

NO >> Check DTC with BCM. Refer to [BCS-15, "COMMON ITEM : CONSULT Function \(BCM - COMMON ITEM\)"](#).

## 3.CHECK PNP SWITCH INPUT SIGNAL CIRCUIT FOR OPEN AND SHORT

1. Turn ignition switch OFF.
2. Disconnect A/T assembly harness connector.
3. Disconnect ECM harness connector.
4. Check the continuity between A/T assembly harness connector and ECM harness connector.



# P0850 PNP SWITCH

< DTC/CIRCUIT DIAGNOSIS >

[VQ37VHR FOR USA AND CANADA]

| A/T assembly |          | ECM       |          | Continuity |
|--------------|----------|-----------|----------|------------|
| Connector    | Terminal | Connector | Terminal |            |
| F61          | 9        | M107      | 109      | Existed    |

5. Also check harness for short to ground and short to power.

Is the inspection result normal?

- YES >> GO TO 5.
- NO >> GO TO 4.

## 4. DETECT MALFUNCTIONING PART

Check the following.

- Harness connectors F40, E20
- Harness connectors E106, M6
- Harness connectors M20, M30
- Harness for open or short between A/T assembly and ECM

>> Repair open circuit, short to ground or short to power in harness or connectors.

## 5. CHECK INTERMITTENT INCIDENT

Refer to [GI-44, "Intermittent Incident"](#).

>> INSPECTION END

A

EC

C

D

E

F

G

H

I

J

K

L

M

N

O

P

# P100A, P100B VVEL SYSTEM

< DTC/CIRCUIT DIAGNOSIS >

[VQ37VHR FOR USA AND CANADA]

## P100A, P100B VVEL SYSTEM

### DTC Logic

INFOID:000000006883034

#### DTC DETECTION LOGIC

##### NOTE:

If DTC P100A or P100B is displayed with DTC P1090 or P1093, first perform the trouble diagnosis for DTC P1090 or P1093. Refer to [EC-406, "DTC Logic"](#).

| DTC No. | Trouble diagnosis name             | DTC detecting condition                  | Possible cause  |
|---------|------------------------------------|--|---|
| P100A   | VVEL response malfunction (bank 1) | Actual event response to target is poor. | <ul style="list-style-type: none"><li>• Harness or connectors (VVEL actuator motor circuit is open or shorted.)</li><li>• VVEL actuator motor</li><li>• VVEL actuator sub assembly</li><li>• VVEL ladder assembly</li><li>• VVEL control module</li></ul> |
| P100B   | VVEL response malfunction (bank 2) |  |   |

#### DTC CONFIRMATION PROCEDURE

##### 1. PRECONDITIONING

If DTC Confirmation Procedure has been previously conducted, always perform the following procedure before conducting the next test.

1. Turn ignition switch OFF and wait at least 10 seconds.
2. Turn ignition switch ON.
3. Turn ignition switch OFF and wait at least 10 seconds.

##### TESTING CONDITION:

**Before performing the following procedure, confirm that battery voltage is more than 10 V at idle.**

>> GO TO 2.

##### 2. PERFORM DTC CONFIRMATION PROCEDURE

1. Start engine.
2. Depress the accelerator pedal rapidly half or more under no load conditions, and then release it.
3. Wait at idle for 5 seconds or more.
4. Repeat steps 2 to 3 for three times.
5. Check 1st trip DTC.

Is DTC detected?

YES >> Go to [EC-394, "Diagnosis Procedure"](#).

NO >> INSPECTION END

#### Diagnosis Procedure

INFOID:000000006883035

##### 1. CHECK GROUND CONNECTION

1. Turn ignition switch OFF.
2. Check ground connection M95. Refer to Ground Inspection in [GI-47, "Circuit Inspection"](#).

Is the inspection result normal?

YES >> GO TO 2.

NO >> Repair or replace ground connection.

##### 2. VVEL ACTUATOR MOTOR OUTPUT SIGNAL CIRCUIT FOR OPEN AND SHORT

1. Disconnect VVEL control module harness connector.
2. Disconnect VVEL actuator motor harness connector.
3. Check the continuity between VVEL control module harness connector and VVEL actuator motor harness connector.

# P100A, P100B VVEL SYSTEM

< DTC/CIRCUIT DIAGNOSIS >

[VQ37VHR FOR USA AND CANADA]

| DTC No. | VVEL control module |           |          | VVEL actuator motor |          | Continuity  |
|---------|---------------------|-----------|----------|---------------------|----------|-------------|
|         | Bank                | Connector | Terminal | Connector           | Terminal |             |
| P100A   | 1                   | E15       | 12       | F48                 | 1        | Existed     |
|         |                     |           |          |                     | 2        | Not existed |
|         |                     |           | 25       |                     | 1        | Not existed |
|         |                     |           |          |                     | 2        | Existed     |
| P100B   | 2                   |           | 2        | F49                 | 1        | Existed     |
|         |                     |           |          |                     | 2        | Not existed |
|         |                     |           | 15       |                     | 1        | Not existed |
|         |                     |           |          |                     | 2        | Existed     |

4. Also check harness for short to ground and power.

Is the inspection result normal?

YES >> GO TO 4.

NO >> GO TO 3.

## 3. DETECT MALFUNCTIONING PART

Check the following.

- Harness connectors F40, E20
- Harness for open or short between VVEL actuator motor and VVEL control module

>> Repair open circuit, short to ground or short to power in harness or connectors.

## 4. CHECK VVEL ACTUATOR MOTOR

Refer to [EC-396, "Component Inspection \(VVEL ACTUATOR MOTOR\)"](#).

Is the inspection result normal?

YES >> GO TO 6.

NO >> GO TO 5.

## 5. REPLACE VVEL ACTUATOR SUB ASSEMBLY

1. Replace VVEL actuator sub assembly.
2. Go to [EC-397, "Special Repair Requirement"](#).

>> INSPECTION END

## 6. CHECK INTERMITTENT INCIDENT

Refer to [GI-44, "Intermittent Incident"](#).

Is the inspection result normal?

YES >> GO TO 7.

NO >> Repair or replace.

## 7. REPLACE VVEL CONTROL MODULE

1. Replace VVEL control module.
2. Go to [EC-145, "Work Procedure"](#).

>> GO TO 8.

## 8. PERFORM DTC CONFIRMATION PROCEDURE

1. Turn ignition switch ON.
2. Erase DTC.
3. Perform DTC Confirmation Procedure.  
See [EC-394, "DTC Logic"](#).

Is the DTC P100A or P100B displayed again?

YES >> GO TO 9.

# P100A, P100B VVEL SYSTEM

[VQ37VHR FOR USA AND CANADA]

< DTC/CIRCUIT DIAGNOSIS >

NO >> INSPECTION END

## 9. CHECK VVEL ACTUATOR SUB ASSEMBLY

Refer to [EC-396, "Component Inspection \(VVEL ACTUATOR SUB ASSEMBLY\)"](#).

Is the inspection result normal?

YES >> GO TO 11.

NO >> GO TO 10.

## 10. REPLACE VVEL ACTUATOR SUB ASSEMBLY

1. Replace VVEL actuator sub assembly.
2. Go to [EC-397, "Special Repair Requirement"](#).

>> INSPECTION END

## 11. CHECK VVEL LADDER ASSEMBLY

Refer to [EM-106, "Inspection"](#).

Is the inspection result normal?

YES >> GO TO 13.

NO >> GO TO 12.

## 12. REPLACE CYLINDER HEAD, VVEL LADDER ASSEMBLY AND VVEL ACTUATOR SUB ASSEMBLY

1. Replace cylinder head, VVEL ladder assembly and VVEL actuator sub assembly.
2. Go to [EC-397, "Special Repair Requirement"](#).

>> INSPECTION END

## 13. CHECK INTERMITTENT INCIDENT

Refer to [GI-44, "Intermittent Incident"](#).

>> INSPECTION END

## Component Inspection (VVEL ACTUATOR MOTOR)

INFOID:000000006883036

### 1. CHECK VVEL ACTUATOR MOTOR

1. Turn ignition switch OFF.
2. Disconnect VVEL actuator motor harness connector.
3. Check resistance between VVEL actuator motor terminals as follows.

| VVEL actuator motor | Resistance          |
|---------------------|---------------------|
| Terminal            |                     |
| 1 and 2             | 16 $\Omega$ or less |

Is the inspection result normal?

YES >> INSPECTION END

NO >> GO TO 2.

### 2. REPLACE VVEL ACTUATOR SUB ASSEMBLY

1. Replace VVEL actuator sub assembly.
2. Go to [EC-397, "Special Repair Requirement"](#).

>> INSPECTION END

## Component Inspection (VVEL ACTUATOR SUB ASSEMBLY)

INFOID:000000006883037

### 1. CHECK VVEL ACTUATOR SUB ASSEMBLY

1. Turn ignition switch OFF.
2. Remove VVEL actuator sub assembly. Refer to [EM-97, "Disassembly and Assembly"](#).

# P100A, P100B VVEL SYSTEM

[VQ37VHR FOR USA AND CANADA]

< DTC/CIRCUIT DIAGNOSIS >

3. Turn the ball screw shaft to check that it works smoothly.

Is the inspection result normal?

YES >> INSPECTION END

NO >> GO TO 2.

## 2.REPLACE VVEL ACTUATOR SUB ASSEMBLY

1. Replace VVEL actuator sub assembly.

2. Go to [EC-397](#). "Special Repair Requirement".

>> INSPECTION END

## Special Repair Requirement

INFOID:000000006883038

## 1.PERFORM VVEL CONTROL SHAFT POSITION SENSOR ADJUSTMENT

Refer to [EC-151](#). "Work Procedure".

>> GO TO 2.

## 2.PERFORM IDLE AIR VOLUME LEARNING

Refer to [EC-149](#). "Work Procedure".

>> END

A

EC

C

D

E

F

G

H

I

J

K

L

M

N

O

P

# P1087, P1088 VVEL SYSTEM

< DTC/CIRCUIT DIAGNOSIS >

[VQ37VHR FOR USA AND CANADA]

## P1087, P1088 VVEL SYSTEM

### DTC Logic

INFOID:000000006883039

### DTC DETECTION LOGIC

**NOTE:**

If DTC P1087 or P1088 is displayed with DTC P1090 or P1093.

Perform the trouble diagnosis for DTC P1090 or P1093. Refer to [EC-402, "DTC Logic"](#).

| DTC No. | Trouble diagnosis name                      | DTC detecting condition                                | Possible cause  |
|---------|---|--|---|
| P1087   | VVEL small event angle malfunction (bank 1) | The event angle of VVEL control shaft is always small. | <ul style="list-style-type: none"><li>• Harness or connectors (VVEL actuator motor circuit is open or shorted.)</li><li>• VVEL actuator motor</li><li>• VVEL actuator sub assembly</li><li>• VVEL ladder assembly</li><li>• VVEL control module</li></ul> |
| P1088   | VVEL small event angle malfunction (bank 2) |  |   |

# P1089, P1092 VVEL CONTROL SHAFT POSITION SENSOR

< DTC/CIRCUIT DIAGNOSIS >

[VQ37VHR FOR USA AND CANADA]

## P1089, P1092 VVEL CONTROL SHAFT POSITION SENSOR

### DTC Logic

INFOID:000000006883040

### DTC DETECTION LOGIC

#### NOTE:

If DTC P1089 or P1092 is displayed with DTC P1608, first perform the trouble diagnosis for DTC P1608. Refer to [EC-479. "DTC Logic"](#).

| DTC No. | Trouble diagnosis name                              | DTC detecting condition  | Possible cause  |
|---------|---|--|---|
| P1089   | VVEL control shaft position sensor (bank 1) circuit | <ul style="list-style-type: none"><li>• An excessively low voltage from the sensor is sent to VVEL control module.</li><li>• An excessively high voltage from the sensor is sent to VVEL control module.</li><li>• Rationally incorrect voltage is sent to VVEL control module compared with the signals from VVEL control shaft position sensor 1 and VVEL control shaft position sensor 2.</li></ul> | <ul style="list-style-type: none"><li>• Harness or connectors (VVEL control shaft position sensor circuit is open or shorted.)</li><li>• VVEL control shaft position sensor</li><li>• VVEL control module</li></ul> |
| P1092   | VVEL control shaft position sensor (bank 2) circuit |  |   |

### DTC CONFIRMATION PROCEDURE

#### 1. PRECONDITIONING

If DTC Confirmation Procedure has been previously conducted, always perform the following procedure before conducting the next test.

1. Turn ignition switch OFF and wait at least 10 seconds.
2. Turn ignition switch ON.
3. Turn ignition switch OFF and wait at least 10 seconds.

#### TESTING CONDITION:

Before performing the following procedure, confirm that battery voltage is more than 10 V at idle.

>> GO TO 2.

#### 2. PERFORM DTC CONFIRMATION PROCEDURE

1. Start engine and let it idle for 1 second.
2. Check DTC.

#### Is DTC detected?

- YES >> Go to [EC-399. "Diagnosis Procedure"](#).  
NO >> INSPECTION END

### Diagnosis Procedure

INFOID:000000006883041

#### 1. CHECK GROUND CONNECTION

1. Turn ignition switch OFF.
2. Check ground connection M95. Refer to Ground Inspection in [GI-47. "Circuit Inspection"](#).

#### Is the inspection result normal?

- YES >> GO TO 2.  
NO >> Repair or replace ground connection.

#### 2. VVEL CONTROL SHAFT POSITION SENSOR POWER SUPPLY CIRCUIT

1. Disconnect VVEL control shaft position sensor harness connector.
2. Turn ignition switch ON.
3. Check the voltage between VVEL control shaft position sensor harness connector and ground.

# P1089, P1092 VVEL CONTROL SHAFT POSITION SENSOR

< DTC/CIRCUIT DIAGNOSIS >

[VQ37VHR FOR USA AND CANADA]

| DTC No. | VVEL control shaft position sensor |           |          | Ground | Voltage (V) |
|---------|------------------------------------|-----------|----------|--------|-------------|
|         | Bank                               | Connector | Terminal |        |             |
| P1089   | 1                                  | F46       | 3        | Ground | Approx. 5   |
|         |                                    |           | 6        |        |             |
| P1092   | 2                                  | F47       | 3        |        |             |
|         |                                    |           | 6        |        |             |

Is the inspection result normal?

YES >> GO TO 4.

NO >> GO TO 3.

## 3. DETECT MALFUNCTIONING PART

Check the following.

- Harness connectors F40, E20
- Harness for open or short between VVEL control shaft position sensor and VVEL control module

>> Repair open circuit, short to ground or short to power in harness or connectors.

## 4. CHECK VVEL CONTROL SHAFT POSITION SENSOR GROUND CIRCUIT FOR OPEN AND SHORT

1. Turn ignition switch OFF.
2. Disconnect VVEL control module harness connector.
3. Check the continuity between VVEL control shaft position sensor harness connector and VVEL control module harness connector.

| DTC No. | VVEL control shaft position sensor |           |          | VVEL control module |          | Continuity |
|---------|------------------------------------|-----------|----------|---------------------|----------|------------|
|         | Bank                               | Connector | Terminal | Connector           | Terminal |            |
| P1089   | 1                                  | F46       | 2        | E15                 | 4        | Existed    |
|         |                                    |           | 5        |                     | 17       |            |
| P1092   | 2                                  | F47       | 2        |                     | 6        |            |
|         |                                    |           | 5        |                     | 19       |            |

4. Also check harness for short to ground and power.

Is the inspection result normal?

YES >> GO TO 6.

NO >> GO TO 5.

## 5. DETECT MALFUNCTIONING PART

Check the following.

- Harness connectors F40, E20
- Harness for open or short between VVEL control shaft position sensor and VVEL control module

>> Repair open circuit, short to ground or short to power in harness or connectors.

## 6. VVEL CONTROL SHAFT POSITION SENSOR INPUT SIGNAL CIRCUIT FOR OPEN AND SHORT

1. Check the continuity between VVEL control shaft position sensor harness connector and VVEL control module harness connector.

| DTC No. | VVEL control shaft position sensor |           |          | VVEL control module |          | Continuity |
|---------|------------------------------------|-----------|----------|---------------------|----------|------------|
|         | Bank                               | Connector | Terminal | Connector           | Terminal |            |
| P1089   | 1                                  | F46       | 1        | E15                 | 3        | Existed    |
|         |                                    |           | 4        |                     | 16       |            |
| P1092   | 2                                  | F47       | 1        |                     | 5        |            |
|         |                                    |           | 4        |                     | 18       |            |



# P1089, P1092 VVEL CONTROL SHAFT POSITION SENSOR

[VQ37VHR FOR USA AND CANADA]

< DTC/CIRCUIT DIAGNOSIS >

2. Also check harness for short to ground and power.

Is the inspection result normal?

YES >> GO TO 8.

NO >> GO TO 7.

## 7. DETECT MALFUNCTIONING PART

Check the following.

- Harness connectors F40, E20
- Harness for open or short between VVEL control shaft position sensor and VVEL control module

>> Repair open circuit, short to ground or short to power in harness or connectors.

## 8. CHECK INTERMITTENT INCIDENT

Refer to [GI-44. "Intermittent Incident"](#).

Is the inspection result normal?

YES >> GO TO 9.

NO >> Repair or replace.

## 9. REPLACE VVEL CONTROL MODULE

1. Replace VVEL control module.
2. Go to [EC-145. "Work Procedure"](#).

>> GO TO 10.

## 10. PERFORM DTC CONFIRMATION PROCEDURE

1. Turn ignition switch ON.
2. Erase DTC.
3. Perform DTC Confirmation Procedure.  
See [EC-399. "DTC Logic"](#).

Is the DTC P1089 or P1092 displayed again?

YES >> GO TO 11.

NO >> INSPECTION END

## 11. REPLACE VVEL ACTUATOR SUB ASSEMBLY

1. Replace VVEL actuator sub assembly.
2. Go to [EC-401. "Special Repair Requirement"](#).

>> INSPECTION END

## Special Repair Requirement

INFOID:000000006883042

### 1. PERFORM VVEL CONTROL SHAFT POSITION SENSOR ADJUSTMENT

Refer to [EC-151. "Work Procedure"](#).

>> GO TO 2.

### 2. PERFORM IDLE AIR VOLUME LEARNING

Refer to [EC-149. "Work Procedure"](#).

>> END

# P1090, P1093 VVEL ACTUATOR MOTOR

< DTC/CIRCUIT DIAGNOSIS >

[VQ37VHR FOR USA AND CANADA]

## P1090, P1093 VVEL ACTUATOR MOTOR

### DTC Logic

INFOID:000000006883043

#### DTC DETECTION LOGIC

##### NOTE:

If DTC P1090 or P1093 is displayed with DTC P1091, first perform the trouble diagnosis for DTC P1091. Refer to [EC-406. "DTC Logic"](#).

| DTC No. | Trouble diagnosis name           | DTC detecting condition  | Possible cause  |
|---------|----------------------------------|--|---|
| P1090   | VVEL system performance (bank 1) | <ul style="list-style-type: none"><li>Event angle difference between the actual and the target is detected.</li><li>Abnormal current is sent to VVEL actuator motor.</li></ul> | <ul style="list-style-type: none"><li>Harness or connectors (VVEL actuator motor circuit is open or shorted.)</li><li>VVEL actuator motor</li><li>VVEL actuator sub assembly</li><li>VVEL ladder assembly</li><li>VVEL control module</li></ul> |
| P1093   | VVEL system performance (bank 2) |  |   |

#### DTC CONFIRMATION PROCEDURE

##### 1. PRECONDITIONING

If DTC Confirmation Procedure has been previously conducted, always perform the following procedure before conducting the next test.

- Turn ignition switch OFF and wait at least 10 seconds.
- Turn ignition switch ON.
- Turn ignition switch OFF and wait at least 10 seconds.

##### TESTING CONDITION:

Before performing the following procedure, confirm that battery voltage is more than 10 V at idle.

>> GO TO 2.

##### 2. PERFORM DTC CONFIRMATION PROCEDURE

- Start engine and let it idle for 10 second.
- Keep the engine speed at about 3,500 rpm for at least 10 seconds under no load.
- Check DTC.

Is DTC detected?

- YES >> Go to [EC-402. "Diagnosis Procedure"](#).  
NO >> INSPECTION END

#### Diagnosis Procedure

INFOID:000000006883044

##### 1. CHECK GROUND CONNECTION

- Turn ignition switch OFF.
- Check ground connection M95. Refer to Ground Inspection in [GI-47. "Circuit Inspection"](#).

Is the inspection result normal?

- YES >> GO TO 2.  
NO >> Repair or replace ground connection.

##### 2. VVEL ACTUATOR MOTOR OUTPUT SIGNAL CIRCUIT FOR OPEN AND SHORT

- Disconnect VVEL control module harness connector.
- Disconnect VVEL actuator motor harness connector.
- Check the continuity between VVEL control module harness connector and VVEL actuator motor harness connector.

# P1090, P1093 VVEL ACTUATOR MOTOR

< DTC/CIRCUIT DIAGNOSIS >

[VQ37VHR FOR USA AND CANADA]

| DTC No. | VVEL control module |           |          | VVEL actuator motor |          | Continuity  |
|---------|---------------------|-----------|----------|---------------------|----------|-------------|
|         | Bank                | Connector | Terminal | Connector           | Terminal |             |
| P1090   | 1                   | E15       | 12       | F48                 | 1        | Existed     |
|         |                     |           |          |                     | 2        | Not existed |
|         |                     |           | 25       |                     | 1        | Not existed |
|         |                     |           |          |                     | 2        | Existed     |
| P1093   | 2                   |           | 2        | F49                 | 1        | Existed     |
|         |                     |           |          |                     | 2        | Not existed |
|         |                     |           | 15       |                     | 1        | Not existed |
|         |                     |           |          |                     | 2        | Existed     |

4. Also check harness for short to ground and power.

Is the inspection result normal?

YES >> GO TO 4.

NO >> GO TO 3.

## 3. DETECT MALFUNCTIONING PART

Check the following.

- Harness connectors F40, E20
- Harness for open or short between VVEL actuator motor and VVEL control module

>> Repair open circuit, short to ground or short to power in harness or connectors.

## 4. CHECK VVEL ACTUATOR MOTOR

Refer to [EC-404, "Component Inspection \(VVEL ACTUATOR MOTOR\)"](#).

Is the inspection result normal?

YES >> GO TO 6.

NO >> GO TO 5.

## 5. REPLACE VVEL ACTUATOR SUB ASSEMBLY

1. Replace VVEL actuator sub assembly.
2. Go to [EC-405, "Special Repair Requirement"](#).

>> INSPECTION END

## 6. CHECK INTERMITTENT INCIDENT

Refer to [GI-44, "Intermittent Incident"](#).

Is the inspection result normal?

YES >> GO TO 7.

NO >> Repair or replace.

## 7. REPLACE VVEL CONTROL MODULE

1. Replace VVEL control module.
2. Go to [EC-145, "Work Procedure"](#).

>> GO TO 8.

## 8. PERFORM DTC CONFIRMATION PROCEDURE

1. Turn ignition switch ON.
2. Erase DTC.
3. Perform DTC Confirmation Procedure.  
See [EC-402, "DTC Logic"](#).

Is the DTC P1090 or P1093 displayed again?

YES >> GO TO 9.

# P1090, P1093 VVEL ACTUATOR MOTOR

[VQ37VHR FOR USA AND CANADA]

< DTC/CIRCUIT DIAGNOSIS >

NO >> INSPECTION END

## 9. CHECK VVEL ACTUATOR SUB ASSEMBLY

Refer to [EC-404, "Component Inspection \(VVEL ACTUATOR SUB ASSEMBLY\)"](#).

Is the inspection result normal?

YES >> GO TO 11.

NO >> GO TO 10.

## 10. REPLACE VVEL ACTUATOR SUB ASSEMBLY

1. Replace VVEL actuator sub assembly.
2. Go to [EC-405, "Special Repair Requirement"](#).

>> INSPECTION END

## 11. CHECK VVEL LADDER ASSEMBLY

Refer to [EM-106, "Inspection"](#).

Is the inspection result normal?

YES >> GO TO 13.

NO >> GO TO 12.

## 12. REPLACE CYLINDER HEAD, VVEL LADDER ASSEMBLY AND VVEL ACTUATOR SUB ASSEMBLY

1. Replace cylinder head, VVEL ladder assembly and VVEL actuator sub assembly.
2. Go to [EC-405, "Special Repair Requirement"](#).

>> INSPECTION END

## 13. CHECK INTERMITTENT INCIDENT

Refer to [GI-44, "Intermittent Incident"](#).

>> INSPECTION END

## Component Inspection (VVEL ACTUATOR MOTOR)

INFOID:000000006883045

### 1. CHECK VVEL ACTUATOR MOTOR

1. Turn ignition switch OFF.
2. Disconnect VVEL actuator motor harness connector.
3. Check resistance between VVEL actuator motor terminals as follows.

| VVEL actuator motor | Resistance          |
|---------------------|---------------------|
| Terminal            |                     |
| 1 and 2             | 16 $\Omega$ or less |

Is the inspection result normal?

YES >> INSPECTION END

NO >> GO TO 2.

### 2. REPLACE VVEL ACTUATOR SUB ASSEMBLY

1. Replace VVEL actuator sub assembly.
2. Go to [EC-405, "Special Repair Requirement"](#).

>> INSPECTION END

## Component Inspection (VVEL ACTUATOR SUB ASSEMBLY)

INFOID:000000006883046

### 1. CHECK VVEL ACTUATOR SUB ASSEMBLY

1. Turn ignition switch OFF.
2. Remove VVEL actuator sub assembly. Refer to [EM-97, "Disassembly and Assembly"](#).

# P1090, P1093 VVEL ACTUATOR MOTOR

[VQ37VHR FOR USA AND CANADA]

< DTC/CIRCUIT DIAGNOSIS >

3. Turn the ball screw shaft to check that it works smoothly.

Is the inspection result normal?

YES >> INSPECTION END

NO >> GO TO 2.

## 2.REPLACE VVEL ACTUATOR SUB ASSEMBLY

1. Replace VVEL actuator sub assembly.

2. Go to [EC-405. "Special Repair Requirement"](#).

>> INSPECTION END

## Special Repair Requirement

INFOID:000000006883047

## 1.PERFORM VVEL CONTROL SHAFT POSITION SENSOR ADJUSTMENT

Refer to [EC-151. "Work Procedure"](#).

>> GO TO 2.

## 2.PERFORM IDLE AIR VOLUME LEARNING

Refer to [EC-149. "Work Procedure"](#).

>> END

A

EC

C

D

E

F

G

H

I

J

K

L

M

N

O

P

# P1091 VVEL ACTUATOR MOTOR RELAY

< DTC/CIRCUIT DIAGNOSIS >

[VQ37VHR FOR USA AND CANADA]

## P1091 VVEL ACTUATOR MOTOR RELAY

### DTC Logic

INFOID:000000006883048

### DTC DETECTION LOGIC

| DTC No. | Trouble diagnosis name            | DTC detecting condition  | Possible cause  |
|---------|-----------------------------------|--|---|
| P1091   | VVEL actuator motor relay circuit | <ul style="list-style-type: none"><li>VVEL control module detects the VVEL actuator motor relay is stuck OFF.</li><li>VVEL control module detects the VVEL actuator motor relay is stuck ON.</li></ul> | <ul style="list-style-type: none"><li>Harness or connectors (VVEL actuator motor relay circuit is open or shorted.) (Abort circuit is open or shorted.)</li><li>VVEL actuator motor relay</li><li>VVEL control module</li><li>ECM</li></ul> |

### DTC CONFIRMATION PROCEDURE

#### 1. PRECONDITIONING

If DTC Confirmation Procedure has been previously conducted, always perform the following procedure before conducting the next test.

- Turn ignition switch OFF and wait at least 10 seconds.
- Turn ignition switch ON.
- Turn ignition switch OFF and wait at least 10 seconds.

#### TESTING CONDITION:

Before performing the following procedure, confirm that battery voltage is more than 10 V at idle.

>> GO TO 2.

#### 2. PERFORM DTC CONFIRMATION PROCEDURE

- Turn ignition switch ON and wait at least 1 seconds.
- Turn ignition switch OFF and wait at least 10 seconds.
- Turn ignition switch ON and wait at least 1 seconds.
- Check DTC.

Is DTC detected?

YES >> Go to [EC-406. "Diagnosis Procedure"](#).

NO >> INSPECTION END

### Diagnosis Procedure

INFOID:000000006883049

#### 1. VVEL ACTUATOR MOTOR RELAY POWER SUPPLY CIRCUIT-I

- Turn ignition switch OFF.
- Disconnect VVEL actuator motor relay.
- Check the voltage between VVEL actuator motor relay harness connector and ground.

| VVEL actuator motor relay |          | Ground | Voltage         |
|---------------------------|----------|--------|-----------------|
| Connector                 | Terminal |        |                 |
| E16                       | 1        | Ground | Battery voltage |
|                           | 5        |        |                 |

Is the inspection result normal?

YES >> GO TO 3.

NO >> GO TO 2.

#### 2. DETECT MALFUNCTIONING PART

Check the following.

- 50 A fusible link (letter G)
- Harness for open or short between VVEL actuator motor relay and battery

# P1091 VVEL ACTUATOR MOTOR RELAY

[VQ37VHR FOR USA AND CANADA]

## < DTC/CIRCUIT DIAGNOSIS >

>> Repair open circuit, short to ground or short to power in harness or connectors.

### 3.VVEL ACTUATOR MOTOR RELAY POWER SUPPLY CIRCUIT-II

1. Disconnect VVEL control module harness connector.
2. Check the continuity between VVEL actuator motor relay harness connector and VVEL control module harness connector.

| VVEL control module |          | VVEL actuator motor relay |          | Continuity |
|---------------------|----------|---------------------------|----------|------------|
| Connector           | Terminal | Connector                 | Terminal |            |
| E15                 | 23       | E16                       | 2        | Existed    |

3. Also check harness for short to ground and power.

Is the inspection result normal?

YES >> GO TO 4.

NO >> Repair open circuit, short to ground or short to power in harness or connectors.

### 4.VVEL ACTUATOR MOTOR RELAY INPUT SIGNAL CIRCUIT FOR OPEN AND SHORT

1. Check the continuity between VVEL actuator motor relay harness connector and VVEL control module harness connector.

| VVEL control module |           |          | VVEL actuator motor relay |          | Continuity |
|---------------------|-----------|----------|---------------------------|----------|------------|
| Bank                | Connector | Terminal | Connector                 | Terminal |            |
| 1                   | E15       | 13       | E16                       | 3        | Existed    |
| 2                   |           | 1        |                           |          |            |

2. Also check harness for short to ground and power.

Is the inspection result normal?

YES >> GO TO 5.

NO >> Repair open circuit, short to ground or short to power in harness or connectors.

### 5.CHECK VVEL ACTUATOR MOTOR RELAY

Refer to [EC-408. "Component Inspection"](#).

Is the inspection result normal?

YES >> GO TO 6.

NO >> Replace VVEL actuator motor relay.

### 6.CHECK ABORT CIRCUIT FOR OPEN AND SHORT

1. Disconnect ECM harness connector.
2. Check the continuity between VVEL control module harness connector and ECM harness connector.

| VVEL control module |          | ECM       |          | Continuity |
|---------------------|----------|-----------|----------|------------|
| Connector           | Terminal | Connector | Terminal |            |
| E15                 | 21       | F101      | 28       | Existed    |

3. Also check harness for short to ground and power.

Is the inspection result normal?

YES >> GO TO 8.

NO >> GO TO 7.

### 7.DETECT MALFUNCTIONING PART

Check the following.

- Harness connector E20, F40
- Harness for open or short between ECM and VVEL control module

>> Repair open circuit, short to ground or short to power in harness or connectors.

### 8.CHECK INTERMITTENT INCIDENT

# P1091 VVEL ACTUATOR MOTOR RELAY

[VQ37VHR FOR USA AND CANADA]

< DTC/CIRCUIT DIAGNOSIS >

Refer to [GI-44, "Intermittent Incident"](#).

Is the inspection result normal?

YES >> GO TO 9.

NO >> Repair or replace.

## 9. REPLACE VVEL CONTROL MODULE

1. Replace VVEL control module.
2. Go to [EC-145, "Work Procedure"](#).

>> GO TO 10.

## 10. PERFORM DTC CONFIRMATION PROCEDURE

1. Turn ignition switch ON.
2. Erase DTC.
3. Perform DTC Confirmation Procedure.  
See [EC-406, "DTC Logic"](#).

Is the DTC P1091 displayed again?

YES >> GO TO 11.

NO >> INSPECTION END

## 11. REPLACE ECM

1. Replace ECM.
2. Go to [EC-144, "Work Procedure"](#).

>> INSPECTION END

## Component Inspection

INFOID:000000006883050

### 1. CHECK VVEL ACTUATOR MOTOR RELAY

1. Turn ignition switch OFF.
2. Remove VVEL actuator motor relay.
3. Check the continuity between VVEL actuator motor relay terminals under the following conditions.

| Terminal | Condition  | Continuity  |
|----------|--|-------------|
| 3 and 5  | 12 V direct current supply between terminals 1 and 2 | Existed     |
|          | No current supply                                    | Not existed |

Is the inspection result normal?

YES >> INSPECTION END

NO >> Replace VVEL actuator motor relay.

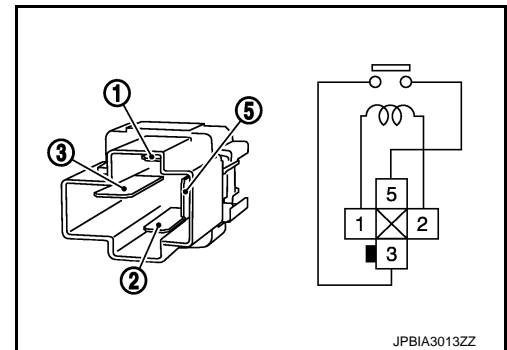



# P1148, P1168 CLOSED LOOP CONTROL

< DTC/CIRCUIT DIAGNOSIS >

[VQ37VHR FOR USA AND CANADA]

## P1148, P1168 CLOSED LOOP CONTROL

### DTC Logic

INFOID:000000006883051

### DTC DETECTION LOGIC

#### NOTE:

**DTC P1148 or P1168 is displayed with DTC for A/F sensor 1.**

**When the DTC is detected, perform the trouble diagnosis of DTC corresponding to A/F sensor 1.**

| DTC No. | Trouble diagnosis name                | DTC detecting condition  | Possible cause  |
|---------|---------------------------------------|--|---|
| P1148   | Closed loop control function (bank 1) | The closed loop control function for bank 1 does not operate even when vehicle is being driven in the specified condition. | <ul style="list-style-type: none"><li>• Harness or connectors (The A/F sensor 1 circuit is open or shorted.)</li><li>• A/F sensor 1</li><li>• A/F sensor 1 heater</li></ul> |
| P1168   | Closed loop control function (bank 2) | The closed loop control function for bank 2 does not operate even when vehicle is being driven in the specified condition. |   |

A

EC

C

D

E

F

G

H

I

J

K

L

M

N

O

P

# P1211 TCS CONTROL UNIT

< DTC/CIRCUIT DIAGNOSIS >

[VQ37VHR FOR USA AND CANADA]

## P1211 TCS CONTROL UNIT

### Description

INFOID:000000006883052

The malfunction information related to TCS is transferred via the CAN communication line from “ABS actuator and electric unit (control unit)” to ECM.

**Be sure to erase the malfunction information such as DTC not only for “ABS actuator and electric unit (control unit)” but also for ECM after TCS related repair.**

### DTC Logic

INFOID:000000006883053

### DTC DETECTION LOGIC

**Freeze frame data is not stored in the ECM for this self-diagnosis.**

| DTC No. | Trouble diagnosis name | DTC detecting condition  | Possible cause  |
|---------|------------------------|--|---|
| P1211   | TCS control unit       | ECM receives malfunction information from “ABS actuator and electric unit (control unit)”. | <ul style="list-style-type: none"><li>• ABS actuator and electric unit (control unit)</li><li>• TCS related parts</li></ul> |

### DTC CONFIRMATION PROCEDURE

#### 1. PRECONDITIONING

#### TESTING CONDITION:

**Before performing the following procedure, confirm that battery voltage is more than 10.5 V at idle.**

>> GO TO 2.

#### 2. PERFORM DTC CONFIRMATION PROCEDURE

1. Start engine and let it idle for at least 60 seconds.
2. Check 1st trip DTC.

Is 1st trip DTC detected?

YES >> [EC-410. "Diagnosis Procedure"](#)

NO >> INSPECTION END

### Diagnosis Procedure

INFOID:000000006883054

Go to [BRC-55. "Work Flow"](#).

# P1212 TCS COMMUNICATION LINE

< DTC/CIRCUIT DIAGNOSIS >

[VQ37VHR FOR USA AND CANADA]

## P1212 TCS COMMUNICATION LINE

### Description

INFOID:000000006883055

This CAN communication line is used to control the smooth engine operation during the TCS operation. Pulse signals are exchanged between ECM and "ABS actuator and electric unit (control unit)".

**Be sure to erase the malfunction information such as DTC not only for "ABS actuator and electric unit (control unit)" but also for ECM after TCS related repair.**

### DTC Logic

INFOID:000000006883056

#### DTC DETECTION LOGIC

##### NOTE:

- If DTC P1212 is displayed with DTC UXXXX, first perform the trouble diagnosis for DTC UXXXX.
- If DTC P1212 is displayed with DTC P0607, first perform the trouble diagnosis for DTC P0607. Refer to [EC-387, "DTC Logic"](#).

Freeze frame data is not stored in the ECM for this self-diagnosis.

| DTC No. | Trouble diagnosis name | DTC detecting condition   | Possible cause   |
|---------|------------------------|---|--|
| P1212   | TCS communication line | ECM cannot receive the information from "ABS actuator and electric unit (control unit)" continuously. | <ul style="list-style-type: none"><li>• Harness or connectors (The CAN communication line is open or shorted.)</li><li>• ABS actuator and electric unit (control unit)</li><li>• Dead (Weak) battery</li></ul> |

#### DTC CONFIRMATION PROCEDURE

##### 1. PRECONDITIONING

##### TESTING CONDITION:

Before performing the following procedure, confirm that battery voltage is more than 10.5 V at idle.

>> GO TO 2.

##### 2. PERFORM DTC CONFIRMATION PROCEDURE

1. Start engine and let it idle for at least 10 seconds.
2. Check 1st trip DTC.

Is 1st trip DTC detected?

- YES >> Go to [EC-411, "Diagnosis Procedure"](#).  
NO >> INSPECTION END

### Diagnosis Procedure

INFOID:000000006883057

Go to [BRC-55, "Work Flow"](#).

# P1217 ENGINE OVER TEMPERATURE

< DTC/CIRCUIT DIAGNOSIS >

[VQ37VHR FOR USA AND CANADA]

## P1217 ENGINE OVER TEMPERATURE

### DTC Logic

INFOID:000000006883058

#### DTC DETECTION LOGIC

##### NOTE:

- If DTC P1217 is displayed with DTC UXXXX, first perform the trouble diagnosis for DTC UXXXX.
- If DTC P1217 is displayed with DTC P0607, first perform the trouble diagnosis for DTC P0607. Refer to [EC-387, "DTC Logic"](#).

If the cooling fan or another component in the cooling system malfunctions, engine coolant temperature will rise.

When the engine coolant temperature reaches an abnormally high temperature condition, a malfunction is indicated.

| DTC No. | Trouble diagnosis name             | DTC detecting condition  | Possible cause  |
|---------|------------------------------------|--|---|
| P1217   | Engine over temperature (Overheat) | <ul style="list-style-type: none"><li>• Cooling fan does not operate properly (Overheat).</li><li>• Cooling fan system does not operate properly (Overheat).</li><li>• Engine coolant was not added to the system using the proper filling method.</li><li>• Engine coolant is not within the specified range.</li></ul> | <ul style="list-style-type: none"><li>• Harness or connectors (The cooling fan circuit is open or shorted.)</li><li>• IPDM E/R</li><li>• Cooling fan control module</li><li>• Cooling fan motor</li><li>• Radiator hose</li><li>• Radiator</li><li>• Radiator cap</li><li>• Water pump</li><li>• Thermostat</li></ul> |

##### CAUTION:

When a malfunction is indicated, always replace the coolant. Refer to [CO-8, "Draining"](#) and [CO-9, "Refilling"](#). Also, replace the engine oil. Refer to [LU-9, "Draining"](#) and [LU-9, "Refilling"](#).

1. Fill radiator with coolant up to specified level with a filling speed of 2 liters per minute. Always use coolant with the proper mixture ratio. Refer to [MA-17, "FOR NORTH AMERICA : Anti-Freeze Coolant Mixture Ratio"](#).
2. After refilling coolant, run engine to ensure that no water-flow noise is emitted.

#### DTC CONFIRMATION PROCEDURE

##### 1. PERFORM COMPONENT FUNCTION CHECK

Perform component function check. Refer to [EC-412, "Component Function Check"](#).

##### NOTE:

Use component function check to check the overall function of the cooling fan. During this check, a DTC might not be confirmed.

Is the inspection result normal?

- YES >> INSPECTION END
- NO >> Go to [EC-413, "Diagnosis Procedure"](#).

#### Component Function Check

INFOID:000000006883059

##### 1. PERFORM COMPONENT FUNCTION CHECK-I

##### WARNING:

Never remove the radiator cap when the engine is hot. Serious burns could be caused by high pressure fluid escaping from the radiator.

Wrap a thick cloth around cap. Carefully remove the cap by turning it a quarter turn to allow built-up pressure to escape. Then turn the cap all the way off.

# P1217 ENGINE OVER TEMPERATURE

[VQ37VHR FOR USA AND CANADA]

## < DTC/CIRCUIT DIAGNOSIS >

Check the coolant level in the reservoir tank and radiator.

**Allow engine to cool before checking coolant level.**

Is the coolant level in the reservoir tank and/or radiator below the proper range?

- YES >> Go to [EC-413, "Diagnosis Procedure"](#).  
NO >> GO TO 2.

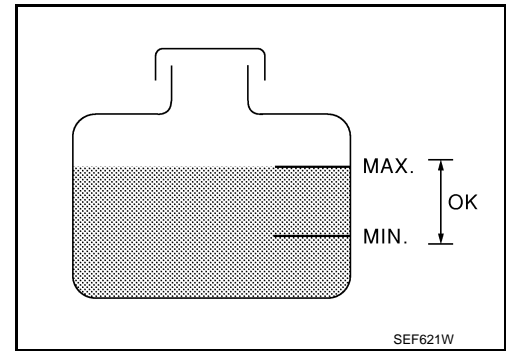

## 2.PERFORM COMPONENT FUNCTION CHECK-II

Confirm whether customer filled the coolant or not.

Did customer fill the coolant?

- YES >> Go to [EC-413, "Diagnosis Procedure"](#).  
NO >> GO TO 3.

## 3.PERFORM COMPONENT FUNCTION CHECK-III

### With CONSULT

1. Turn ignition switch ON.
2. Perform "FAN DUTY CONTROL" in "ACTIVE TEST" mode with CONSULT.
3. Make sure that cooling fan speed varies according to the percentage.

### Without CONSULT

Perform IPDM E/R auto active test and check cooling fan motors operation, refer to [PCS-12, "Diagnosis Description"](#).

Is the inspection result normal?

- YES >> INSPECTION END  
NO >> Go to [EC-413, "Diagnosis Procedure"](#).

## Diagnosis Procedure

INFOID:000000006883060

## 1.CHECK COOLING FAN OPERATION

### With CONSULT

1. Turn ignition switch ON.
2. Perform "FAN DUTY CONTROL" in "ACTIVE TEST" mode with CONSULT.
3. Make sure that cooling fan speed varies according to the percentage.

### Without CONSULT

1. Perform IPDM E/R auto active test and check cooling fan motors operation, refer to [PCS-12, "Diagnosis Description"](#).
2. Make sure that cooling fan operates.

Is the inspection result normal?

- YES >> GO TO 2.  
NO >> Go to [EC-506, "Diagnosis Procedure"](#).

## 2.CHECK COOLING SYSTEM FOR LEAK-I

Check cooling system for leak. Refer to [CO-8, "Inspection"](#).

Is leakage detected?

- YES >> GO TO 3.  
NO >> GO TO 4.

## 3.CHECK COOLING SYSTEM FOR LEAK-II

Check the following for leak.

- Hose
- Radiator
- Water pump

# P1217 ENGINE OVER TEMPERATURE

< DTC/CIRCUIT DIAGNOSIS >

[VQ37VHR FOR USA AND CANADA]

>> Repair or replace malfunctioning part.

## 4. CHECK RADIATOR CAP

Check radiator cap. Refer to [CO-12, "RADIATOR CAP : Inspection"](#).

Is the inspection result normal?

YES >> GO TO 5.

NO >> Replace radiator cap. Refer to [CO-25, "Exploded View"](#).

## 5. CHECK THERMOSTAT

Check thermostat. Refer to [CO-24, "Inspection"](#).

Is the inspection result normal?

YES >> GO TO 6.

NO >> Replace thermostat. Refer to [CO-23, "Exploded View"](#).

## 6. CHECK ENGINE COOLANT TEMPERATURE SENSOR

Refer to [EC-232, "Component Inspection"](#).

Is the inspection result normal?

YES >> GO TO 7.

NO >> Replace engine coolant temperature sensor. Refer to [CO-25, "Exploded View"](#).

## 7. CHECK MAIN 12 CAUSES

If the cause cannot be isolated, check the following.

| Engine | Step | Inspection item  | Equipment  | Standard   | Reference page                                     |
|--------|------|--|--|--|--|
| OFF    | 1    | <ul style="list-style-type: none"> <li>Blocked radiator</li> <li>Blocked condenser</li> <li>Blocked radiator grille</li> <li>Blocked bumper</li> </ul> | <ul style="list-style-type: none"> <li>Visual</li> </ul>                                       | No blocking  | —  |
|        | 2    | <ul style="list-style-type: none"> <li>Coolant mixture</li> </ul>  | <ul style="list-style-type: none"> <li>Coolant tester</li> </ul>                               | <a href="#">MA-17, "FOR NORTH AMERICA : Anti-Freeze Coolant Mixture Ratio"</a> |  |
|        | 3    | <ul style="list-style-type: none"> <li>Coolant level</li> </ul>  | <ul style="list-style-type: none"> <li>Visual</li> </ul>                                       | Coolant up to MAX level in reservoir tank and radiator filler neck             | <a href="#">CO-8, "Inspection"</a>                 |
|        | 4    | <ul style="list-style-type: none"> <li>Radiator cap</li> </ul>   | <ul style="list-style-type: none"> <li>Pressure tester</li> </ul>                              | 107 kPa (1.1 kg/cm <sup>2</sup> , 16 psi) (Limit)                              | <a href="#">CO-12, "RADIATOR CAP : Inspection"</a> |
| ON*2   | 5    | <ul style="list-style-type: none"> <li>Coolant leaks</li> </ul>  | <ul style="list-style-type: none"> <li>Visual</li> </ul>                                       | No leaks   | <a href="#">CO-8, "Inspection"</a>                 |
| ON*2   | 6    | <ul style="list-style-type: none"> <li>Thermostat</li> </ul>   | <ul style="list-style-type: none"> <li>Touch the upper and lower radiator hoses</li> </ul>     | Both hoses should be hot   | <a href="#">CO-24, "Inspection"</a>                |
| ON*1   | 7    | <ul style="list-style-type: none"> <li>Cooling fan</li> </ul>  | <ul style="list-style-type: none"> <li>CONSULT</li> </ul>                                      | Operating  | <a href="#">EC-506, "Component Function Check"</a> |
| OFF    | 8    | <ul style="list-style-type: none"> <li>Combustion gas leak</li> </ul>  | <ul style="list-style-type: none"> <li>Color checker chemical tester 4 Gas analyzer</li> </ul> | Negative   | —  |
| ON*3   | 9    | <ul style="list-style-type: none"> <li>Coolant temperature gauge</li> </ul>  | <ul style="list-style-type: none"> <li>Visual</li> </ul>                                       | Gauge less than 3/4 when driving   | —  |
|        |      | <ul style="list-style-type: none"> <li>Coolant overflow to reservoir tank</li> </ul>   | <ul style="list-style-type: none"> <li>Visual</li> </ul>                                       | No overflow during driving and idling  | <a href="#">CO-8, "Inspection"</a>                 |
| OFF*4  | 10   | <ul style="list-style-type: none"> <li>Coolant return from reservoir tank to radiator</li> </ul>   | <ul style="list-style-type: none"> <li>Visual</li> </ul>                                       | Should be initial level in reservoir tank                                      | <a href="#">CO-8, "Inspection"</a>                 |
| OFF    | 11   | <ul style="list-style-type: none"> <li>Cylinder head</li> </ul>  | <ul style="list-style-type: none"> <li>Straight gauge feeler gauge</li> </ul>                  | 0.1 mm (0.004 in) Maximum distortion (warping)                                 | <a href="#">EM-119, "Inspection"</a>               |
|        | 12   | <ul style="list-style-type: none"> <li>Cylinder block and pistons</li> </ul>   | <ul style="list-style-type: none"> <li>Visual</li> </ul>                                       | No scuffing on cylinder walls or piston  | <a href="#">EM-132, "Inspection"</a>               |

\*1: Turn the ignition switch ON.

\*2: Engine running at 3,000 rpm for 10 minutes.

\*3: Drive at 90 km/h (55 MPH) for 30 minutes and then let idle for 10 minutes.

\*4: After 60 minutes of cool down time.

# P1217 ENGINE OVER TEMPERATURE

< DTC/CIRCUIT DIAGNOSIS >

[VQ37VHR FOR USA AND CANADA]

For more information, refer to [CO-6. "Troubleshooting Chart"](#).

>> INSPECTION END

A

EC

C

D

E

F

G

H

I

J

K

L

M

N

O

P

# P1225, P1234 TP SENSOR

< DTC/CIRCUIT DIAGNOSIS >

[VQ37VHR FOR USA AND CANADA]

## P1225, P1234 TP SENSOR

### DTC Logic

INFOID:000000006883061

### DTC DETECTION LOGIC

| DTC No. | Trouble diagnosis name                                 | DTC detecting condition                                     | Possible cause   |
|---------|--|---|--|
| P1225   | Closed throttle position learning performance (bank 1) | Closed throttle position learning value is excessively low. | • Electric throttle control actuator (TP sensor 1 and 2) |
| P1234   | Closed throttle position learning performance (bank 2) |   |  |

### DTC CONFIRMATION PROCEDURE

#### 1. PRECONDITIONING

If DTC Confirmation Procedure has been previously conducted, always perform the following procedure before conducting the next test.

1. Turn ignition switch OFF and wait at least 10 seconds.
2. Turn ignition switch ON.
3. Turn ignition switch OFF and wait at least 10 seconds.

#### TESTING CONDITION:

Before performing the following procedure, confirm that battery voltage is more than 10 V at idle.

>> GO TO 2.

#### 2. PERFORM DTC CONFIRMATION PROCEDURE

1. Turn ignition switch ON.
2. Turn ignition switch OFF and wait at least 10 seconds.
3. Turn ignition switch ON.
4. Check 1st trip DTC.

Is 1st trip DTC detected?

- YES >> Go to [EC-416, "Diagnosis Procedure"](#).  
NO >> INSPECTION END

### Diagnosis Procedure

INFOID:000000006883062

#### 1. CHECK ELECTRIC THROTTLE CONTROL ACTUATOR VISUALLY

1. Turn ignition switch OFF.
2. Remove the intake air duct.
3. Check if foreign matter is caught between the throttle valve (1) and the housing.

Is the inspection result normal?

- YES >> GO TO 2.  
NO >> Remove the foreign matter and clean the electric throttle control actuator inside, and then perform throttle valve closed position learning. Refer to [EC-148, "Work Procedure"](#).

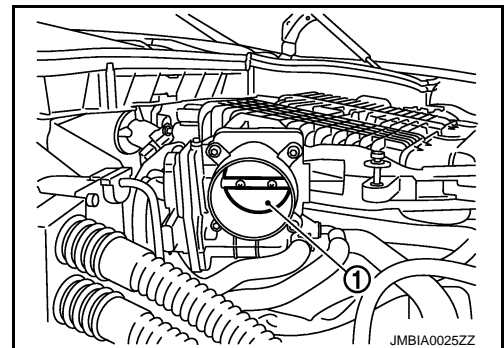

#### 2. REPLACE ELECTRIC THROTTLE CONTROL ACTUATOR

1. Replace malfunctioning electric throttle control actuator.
2. Go to [EC-417, "Special Repair Requirement"](#).

>> INSPECTION END



# P1225, P1234 TP SENSOR

< DTC/CIRCUIT DIAGNOSIS >

[VQ37VHR FOR USA AND CANADA]

## Special Repair Requirement

INFOID:000000006883063

### 1. PERFORM THROTTLE VALVE CLOSED POSITION LEARNING

Refer to [EC-148, "Work Procedure"](#)

>> GO TO 2.

### 2. PERFORM IDLE AIR VOLUME LEARNING

Refer to [EC-149, "Work Procedure"](#)

>> END

A

EC

C

D

E

F

G

H

I

J

K

L

M

N

O

P

# P1226, P1235 TP SENSOR

< DTC/CIRCUIT DIAGNOSIS >

[VQ37VHR FOR USA AND CANADA]

## P1226, P1235 TP SENSOR

### DTC Logic

INFOID:000000006883064

### DTC DETECTION LOGIC

| DTC No. | Trouble diagnosis name                                 | DTC detecting condition  | Possible cause   |
|---------|--|--|--|
| P1226   | Closed throttle position learning performance (bank 1) | Closed throttle position learning is not performed successfully, repeatedly. | <ul style="list-style-type: none"> <li>Electric throttle control actuator (TP sensor 1 and 2)</li> </ul> |
| P1235   | Closed throttle position learning performance (bank 2) |  |  |

### DTC CONFIRMATION PROCEDURE

#### 1. PRECONDITIONING

If DTC Confirmation Procedure has been previously conducted, always perform the following procedure before conducting the next test.

1. Turn ignition switch OFF and wait at least 10 seconds.
2. Turn ignition switch ON.
3. Turn ignition switch OFF and wait at least 10 seconds.

#### TESTING CONDITION:

Before performing the following procedure, confirm that battery voltage is more than 10 V at idle.

>> GO TO 2.

#### 2. PERFORM DTC CONFIRMATION PROCEDURE

1. Turn ignition switch ON.
2. Turn ignition switch OFF and wait at least 10 seconds.
3. Turn ignition switch ON.
4. Repeat steps 2 and 3 for 32 times.
5. Check 1st trip DTC.

Is 1st trip DTC detected?

- YES >> Go to [EC-418, "Diagnosis Procedure"](#).  
 NO >> INSPECTION END

### Diagnosis Procedure

INFOID:000000006883065

#### 1. CHECK ELECTRIC THROTTLE CONTROL ACTUATOR VISUALLY

1. Turn ignition switch OFF.
2. Remove the intake air duct.
3. Check if foreign matter is caught between the throttle valve (1) and the housing.

Is the inspection result normal?

- YES >> GO TO 2.  
 NO >> Remove the foreign matter and clean the electric throttle control actuator inside, and then perform throttle valve closed position learning. Refer to [EC-148, "Work Procedure"](#).

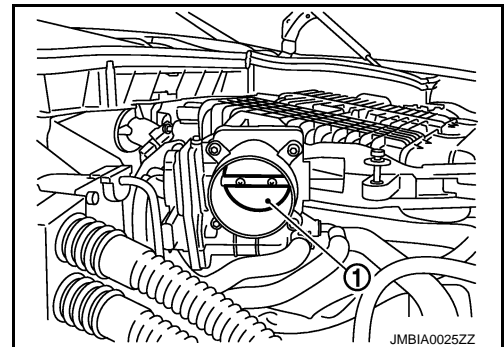

#### 2. REPLACE ELECTRIC THROTTLE CONTROL ACTUATOR

1. Replace malfunctioning electric throttle control actuator.
2. Go to [EC-419, "Special Repair Requirement"](#).

>> INSPECTION END

# P1226, P1235 TP SENSOR

< DTC/CIRCUIT DIAGNOSIS >

[VQ37VHR FOR USA AND CANADA]

## Special Repair Requirement

INFOID:000000006883066

### 1. PERFORM THROTTLE VALVE CLOSED POSITION LEARNING

Refer to [EC-148, "Work Procedure"](#)

>> GO TO 2.

### 2. PERFORM IDLE AIR VOLUME LEARNING

Refer to [EC-149, "Work Procedure"](#)

>> END

A

EC

C

D

E

F

G

H

I

J

K

L

M

N

O

P

# P1233, P2101 ELECTRIC THROTTLE CONTROL FUNCTION

< DTC/CIRCUIT DIAGNOSIS >

[VQ37VHR FOR USA AND CANADA]

## P1233, P2101 ELECTRIC THROTTLE CONTROL FUNCTION

### DTC Logic

INFOID:000000006883067

#### DTC DETECTION LOGIC

##### NOTE:

If DTC P1233 or P2101 is displayed with DTC P1238, P1290, P2100 or 2119, first perform the trouble diagnosis for DTC P1238, P2119 or P1290, P2100. Refer to [EC-427, "DTC Logic"](#) or [EC-432, "DTC Logic"](#).

| DTC No. | Trouble diagnosis name                         | DTC detecting condition                                       | Possible cause   |
|---------|--|---|--|
| P1233   | Electric throttle control performance (bank 2) | Electric throttle control function does not operate properly. | <ul style="list-style-type: none"><li>• Harness or connectors (Throttle control motor circuit is open or shorted)</li><li>• Electric throttle control actuator</li></ul> |
| P2101   | Electric throttle control performance (bank 1) |   |  |

#### DTC CONFIRMATION PROCEDURE

##### 1. PRECONDITIONING

If DTC Confirmation Procedure has been previously conducted, always perform the following procedure before conducting the next test.

1. Turn ignition switch OFF and wait at least 10 seconds.
2. Turn ignition switch ON.
3. Turn ignition switch OFF and wait at least 10 seconds.

##### TESTING CONDITION:

Before performing the following procedure, confirm that battery voltage is more than 11 V when engine is running.

>> GO TO 2.

##### 2. PERFORM DTC CONFIRMATION PROCEDURE

1. Turn ignition switch ON and wait at least 2 seconds.
2. Start engine and let it idle for 5 seconds.
3. Check DTC.

Is DTC detected?

- YES >> Go to [EC-420, "Diagnosis Procedure"](#).  
NO >> INSPECTION END

#### Diagnosis Procedure

INFOID:000000006883068

##### 1. CHECK GROUND CONNECTION

1. Turn ignition switch OFF.
2. Check ground connection M95. Refer to Ground Inspection in [GI-47, "Circuit Inspection"](#).

Is the inspection result normal?

- YES >> GO TO 2.  
NO >> Repair or replace ground connection.

##### 2. CHECK THROTTLE CONTROL MOTOR RELAY INPUT SIGNAL CIRCUIT-I

Check the voltage between ECM harness connector terminals as per the following.

# P1233, P2101 ELECTRIC THROTTLE CONTROL FUNCTION

< DTC/CIRCUIT DIAGNOSIS >

[VQ37VHR FOR USA AND CANADA]

| DTC   | ECM       |          |           |          | Condition       | Voltage (V)     |           |
|-------|-----------|----------|-----------|----------|-----------------|-----------------|-----------|
|       | +         |          | -         |          |                 |                 |           |
|       | Connector | Terminal | Connector | Terminal |                 |                 |           |
| P1233 | F102      | 52       | M107      | 128      | Ignition switch | OFF             | Approx. 0 |
|       |           |          |           |          |                 |                 | ON        |
| P2101 | F101      | 3        |           |          |                 | OFF             | Approx. 0 |
|       |           |          |           | ON       |                 | Battery voltage |           |

Is the inspection result normal?

- YES >> GO TO 9.  
NO >> GO TO 3.

## 3. CHECK THROTTLE CONTROL MOTOR RELAY POWER SUPPLY CIRCUIT

- Turn ignition switch OFF.
- Disconnect ECM harness connector.
- Disconnect IPDM E/R harness connector E7.
- Check the continuity between IPDM E/R harness connector and ECM harness connector.

| IPDM E/R  |          | ECM       |          | Continuity |
|-----------|----------|-----------|----------|------------|
| Connector | Terminal | Connector | Terminal |            |
| E7        | 71       | F101      | 25       | Existed    |

- Also check harness for short to ground and short to power.

Is the inspection result normal?

- YES >> GO TO 5.  
NO >> GO TO 4.

## 4. DETECT MALFUNCTIONING PART

Check the following.

- Harness connectors E20, F40
- Harness for open or short between ECM and IPDM E/R

>> Repair open circuit, short to ground or short to power in harness or connectors.

## 5. CHECK THROTTLE CONTROL MOTOR RELAY INPUT SIGNAL CIRCUIT-II

- Check the continuity between IPDM E/R harness connector and ECM harness connector.

| DTC   | IPDM E/R  |          | ECM       |          | Continuity |
|-------|-----------|----------|-----------|----------|------------|
|       | Connector | Terminal | Connector | Terminal |            |
| P1233 | E5        | 7        | F102      | 52       | Existed    |
| P2101 |           |          | F101      | 3        |            |

- Also check harness for short to ground and short to power.

Is the inspection result normal?

- YES >> GO TO 7.  
NO >> GO TO 6.

## 6. DETECT MALFUNCTIONING PART

Check the following.

- Harness connectors E20, F40
- Harness for open or short between ECM and IPDM E/R

>> Repair open circuit, short to ground or short to power in harness or connectors.

## 7. CHECK FUSE

# P1233, P2101 ELECTRIC THROTTLE CONTROL FUNCTION

[VQ37VHR FOR USA AND CANADA]

## < DTC/CIRCUIT DIAGNOSIS >

1. Disconnect 15 A fuse (No. 50) from IPDM E/R.
2. Check 15 A fuse for blown.

Is the inspection result normal?

- YES >> GO TO 8.  
NO >> Replace 15 A fuse.

## 8.CHECK INTERMITTENT INCIDENT

Refer to [GI-44. "Intermittent Incident"](#).

Is the inspection result normal?

- YES >> Replace IPDM E/R.  
NO >> Repair or replace harness or connectors.

## 9.CHECK THROTTLE CONTROL MOTOR OUTPUT SIGNAL CIRCUIT FOR OPEN OR SHORT

1. Turn ignition switch OFF.
2. Disconnect electric throttle control actuator harness connector.
3. Disconnect ECM harness connector.
4. Check the continuity between electric throttle control actuator harness connector and ECM harness connector.

| DTC   | Electric throttle control actuator |           |          | ECM       |          | Continuity  |
|-------|------------------------------------|-----------|----------|-----------|----------|-------------|
|       | Bank                               | Connector | Terminal | Connector | Terminal |             |
| P1233 | 2                                  | F27       | 5        | F102      | 49       | Existed     |
|       |                                    |           | 6        |           | 50       | Not existed |
|       |                                    |           |          |           | 49       | Not existed |
|       |                                    |           | 50       |           | Existed  |             |
| P2101 | 1                                  | F67       | 1        | F101      | 2        | Existed     |
|       |                                    |           | 2        |           | 4        | Not existed |
|       |                                    |           |          |           | 2        | Not existed |
|       |                                    |           | 4        |           | Existed  |             |

5. Also check harness for short to ground and short to power.

Is the inspection result normal?

- YES >> GO TO 10.  
NO >> Repair or replace.

## 10.CHECK ELECTRIC THROTTLE CONTROL ACTUATOR VISUALLY

1. Remove the intake air duct.
2. Check if foreign matter is caught between the throttle valve (1) and the housing.

Is the inspection result normal?

- YES >> GO TO 11.  
NO >> Remove the foreign matter and clean the electric throttle control actuator inside, and then perform throttle valve closed position leaning. Refer to [EC-148. "Work Procedure"](#).

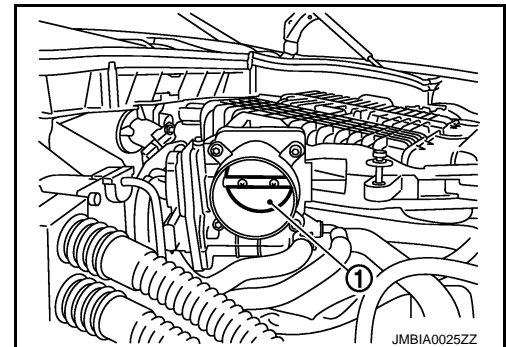

## 11.CHECK THROTTLE CONTROL MOTOR

Refer to [EC-423. "Component Inspection"](#).

Is the inspection result normal?

- YES >> GO TO 12.  
NO >> GO TO 13.

## 12.CHECK INTERMITTENT INCIDENT

# P1233, P2101 ELECTRIC THROTTLE CONTROL FUNCTION

[VQ37VHR FOR USA AND CANADA]

< DTC/CIRCUIT DIAGNOSIS >

Refer to [GI-44. "Intermittent Incident"](#).

Is the inspection result normal?

YES >> GO TO 13.

NO >> Repair or replace harness or connectors.

## 13. REPLACE ELECTRIC THROTTLE CONTROL ACTUATOR

1. Replace malfunction electric throttle control actuator.
2. Go to [EC-423. "Special Repair Requirement"](#).

>> INSPECTION END

## Component Inspection

INFOID:000000006883069

### 1. CHECK THROTTLE CONTROL MOTOR

1. Turn ignition switch OFF.
2. Disconnect electric throttle control actuator harness connector.
3. Check resistance between electric throttle control actuator terminals as per the following.

| Electric throttle control actuator |           | Resistance ( $\Omega$ )         |
|------------------------------------|-----------|---------------------------------|
| Bank                               | Terminals |                                 |
| 1                                  | 1 and 2   | Approx. 1 - 15 [at 25°C (77°F)] |
| 2                                  | 5 and 6   |                                 |

Is the inspection result normal?

YES >> INSPECTION END

NO >> GO TO 2.

### 2. REPLACE ELECTRIC THROTTLE CONTROL ACTUATOR

1. Replace malfunctioning electric throttle control actuator.
2. Go to [EC-423. "Special Repair Requirement"](#).

>> INSPECTION END

## Special Repair Requirement

INFOID:000000006883070

### 1. PERFORM THROTTLE VALVE CLOSED POSITION LEARNING

Refer to [EC-148. "Work Procedure"](#)

>> GO TO 2.

### 2. PERFORM IDLE AIR VOLUME LEARNING

Refer to [EC-149. "Work Procedure"](#)

>> END

# P1236, P2118 THROTTLE CONTROL MOTOR

< DTC/CIRCUIT DIAGNOSIS >

[VQ37VHR FOR USA AND CANADA]

## P1236, P2118 THROTTLE CONTROL MOTOR

### DTC Logic

INFOID:000000006883071

#### DTC DETECTION LOGIC

| DTC No. | Trouble diagnosis name                        | DTC detecting condition  | Possible cause   |
|---------|---|--|--|
| P1236   | Throttle control motor (bank 2) circuit short | ECM detects short in both circuits between ECM and throttle control motor. | <ul style="list-style-type: none"><li>• Harness or connectors (Throttle control motor circuit is shorted.)</li><li>• Electric throttle control actuator (Throttle control motor)</li></ul> |
| P2118   | Throttle control motor (bank 1) circuit short |  |  |

#### DTC CONFIRMATION PROCEDURE

##### 1. PRECONDITIONING

If DTC Confirmation Procedure has been previously conducted, always perform the following procedure before conducting the next test.

1. Turn ignition switch OFF and wait at least 10 seconds.
2. Turn ignition switch ON.
3. Turn ignition switch OFF and wait at least 10 seconds.

>> GO TO 2.

##### 2. PERFORM DTC CONFIRMATION PROCEDURE

1. Turn ignition switch ON and wait at least 2 seconds.
2. Start engine and let it idle for 5 seconds.
3. Check DTC.

Is DTC detected?

- YES >> Go to [EC-424, "Diagnosis Procedure"](#).  
NO >> INSPECTION END

#### Diagnosis Procedure

INFOID:000000006883072

##### 1. CHECK GROUND CONNECTION

1. Turn ignition switch OFF.
2. Check ground connection M95. Refer to Ground Inspection in [GI-47, "Circuit Inspection"](#).

Is the inspection result normal?

- YES >> GO TO 2.  
NO >> Repair or replace ground connection.

##### 2. CHECK THROTTLE CONTROL MOTOR OUTPUT SIGNAL CIRCUIT FOR OPEN AND SHORT

1. Disconnect electric throttle control actuator harness connector.
2. Disconnect ECM harness connector.
3. Check the continuity between electric throttle control actuator harness connector and ECM harness connector.

| DTC   | Electric throttle control actuator |           |          | ECM       |          | Continuity  |
|-------|------------------------------------|-----------|----------|-----------|----------|-------------|
|       | Bank                               | Connector | Terminal | Connector | Terminal |             |
| P1236 | 2                                  | F27       | 5        | F102      | 49       | Existed     |
|       |                                    |           |          |           | 50       | Not existed |
|       |                                    |           | 6        |           | 49       | Not existed |
|       |                                    |           |          |           | 50       | Existed     |



# P1236, P2118 THROTTLE CONTROL MOTOR

< DTC/CIRCUIT DIAGNOSIS >

[VQ37VHR FOR USA AND CANADA]

| DTC   | Electric throttle control actuator |           |          | ECM       |          | Continuity  |
|-------|------------------------------------|-----------|----------|-----------|----------|-------------|
|       | Bank                               | Connector | Terminal | Connector | Terminal |             |
| P2118 | 1                                  | F67       | 1        | F101      | 2        | Existed     |
|       |                                    |           | 2        |           | 4        | Not existed |
|       |                                    |           |          |           | 2        | Not existed |
|       |                                    |           | 4        |           | Existed  |             |

4. Also check harness for short to ground and short to power.

Is the inspection result normal?

YES >> GO TO 3.

NO >> Repair or replace.

## 3. CHECK THROTTLE CONTROL MOTOR

Refer to [EC-425, "Component Inspection"](#).

Is the inspection result normal?

YES >> GO TO 4.

NO >> GO TO 5.

## 4. CHECK INTERMITTENT INCIDENT

Refer to [GI-44, "Intermittent Incident"](#).

Is the inspection result normal?

YES >> GO TO 5.

NO >> Repair or replace harness or connectors.

## 5. REPLACE ELECTRIC THROTTLE CONTROL ACTUATOR

1. Replace malfunctioning electric throttle control actuator.

2. Go to [EC-425, "Special Repair Requirement"](#).

>> INSPECTION END

## Component Inspection

INFOID:000000006883073

## 1. CHECK THROTTLE CONTROL MOTOR

1. Turn ignition switch OFF.

2. Disconnect electric throttle control actuator harness connector.

3. Check resistance between electric throttle control actuator terminals as per the following.

| Electric throttle control actuator |           | Resistance ( $\Omega$ )         |
|------------------------------------|-----------|---------------------------------|
| Bank                               | Terminals |                                 |
| 1                                  | 1 and 2   | Approx. 1 - 15 [at 25°C (77°F)] |
| 2                                  | 5 and 6   |                                 |

Is the inspection result normal?

YES >> INSPECTION END

NO >> GO TO 2.

## 2. REPLACE ELECTRIC THROTTLE CONTROL ACTUATOR

1. Replace malfunctioning electric throttle control actuator.

2. Go to [EC-425, "Special Repair Requirement"](#).

>> INSPECTION END

## Special Repair Requirement

INFOID:000000006883074

## 1. PERFORM THROTTLE VALVE CLOSED POSITION LEARNING

## P1236, P2118 THROTTLE CONTROL MOTOR

< DTC/CIRCUIT DIAGNOSIS >

[VQ37VHR FOR USA AND CANADA]

---

Refer to [EC-148. "Work Procedure"](#)

>> GO TO 2.

### 2.PERFORM IDLE AIR VOLUME LEARNING

---

Refer to [EC-149. "Work Procedure"](#)

>> END

# P1238, P2119 ELECTRIC THROTTLE CONTROL ACTUATOR

< DTC/CIRCUIT DIAGNOSIS >

[VQ37VHR FOR USA AND CANADA]

## P1238, P2119 ELECTRIC THROTTLE CONTROL ACTUATOR

### DTC Logic

INFOID:000000006883075

### DTC DETECTION LOGIC

| DTC No. | Trouble diagnosis name                      | DTC detecting condition |   | Possible cause                       |
|---------|---|-------------------------|---|--------------------------------------|
| P1238   | Electric throttle control actuator (bank 2) | A)                      | Electric throttle control actuator does not function properly due to the return spring malfunction. | • Electric throttle control actuator |
|         |   | B)                      | Throttle valve opening angle in fail-safe mode is not in specified range.                           |                                      |
|         |   | C)                      | ECM detect the throttle valve is stuck open.  |                                      |
| P2119   | Electric throttle control actuator (bank 1) | A)                      | Electric throttle control actuator does not function properly due to the return spring malfunction. |                                      |
|         |   | B)                      | Throttle valve opening angle in fail-safe mode is not in specified range.                           |                                      |
|         |   | C)                      | ECM detect the throttle valve is stuck open.  |                                      |

### DTC CONFIRMATION PROCEDURE

#### 1. PRECONDITIONING

If DTC Confirmation Procedure has been previously conducted, always perform the following procedure before conducting the next test.

1. Turn ignition switch OFF and wait at least 10 seconds.
2. Turn ignition switch ON.
3. Turn ignition switch OFF and wait at least 10 seconds.

>> GO TO 2.

#### 2. PERFORM DTC CONFIRMATION PROCEDURE FOR MALFUNCTION A AND B

1. Turn ignition switch ON and wait at least 1 second.
2. Shift selector lever to D position and wait at least 3 seconds.
3. Shift selector lever to P position.
4. Turn ignition switch OFF and wait at least 10 seconds.
5. Turn ignition switch ON and wait at least 1 second.
6. Shift selector lever to D position and wait at least 3 seconds.
7. Shift selector lever to P position.
8. Turn ignition switch OFF, wait at least 10 seconds, and then turn ON.
9. Check DTC.

Is DTC detected?

YES >> Go to [EC-427, "Diagnosis Procedure"](#).

NO >> GO TO 3.

#### 3. PERFORM DTC CONFIRMATION PROCEDURE FOR MALFUNCTION C

1. Turn ignition switch ON and wait at least 1 second.
2. Shift selector lever to D position and wait at least 3 seconds.
3. Shift selector lever to P position.
4. Start engine and let it idle for 3 seconds.
5. Check DTC.

Is DTC detected?

YES >> Go to [EC-427, "Diagnosis Procedure"](#).

NO >> INSPECTION END

### Diagnosis Procedure

INFOID:000000006883076

#### 1. CHECK ELECTRIC THROTTLE CONTROL ACTUATOR VISUALLY

1. Turn ignition switch OFF.

# P1238, P2119 ELECTRIC THROTTLE CONTROL ACTUATOR

[VQ37VHR FOR USA AND CANADA]

< DTC/CIRCUIT DIAGNOSIS >

2. Remove the intake air duct.
3. Check if foreign matter is caught between the throttle valve (1) and the housing.

Is the inspection result normal?

YES >> GO TO 2.

NO >> Remove the foreign matter and clean the electric throttle control actuator inside, and then perform throttle valve closed position leaning. Refer to [EC-148, "Work Procedure"](#).

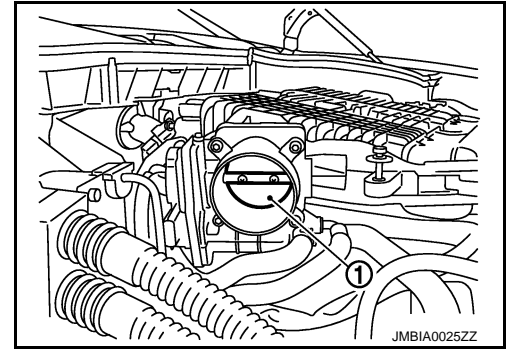

## 2. REPLACE ELECTRIC THROTTLE CONTROL ACTUATOR

1. Replace malfunctioning electric throttle control actuator.
2. Go to [EC-428, "Special Repair Requirement"](#).

>> INSPECTION END

## Special Repair Requirement

INFOID:000000006883077

### 1. PERFORM THROTTLE VALVE CLOSED POSITION LEARNING

Refer to [EC-148, "Work Procedure"](#)

>> GO TO 2.

### 2. PERFORM IDLE AIR VOLUME LEARNING

Refer to [EC-149, "Work Procedure"](#)

>> END

# P1239, P2135 TP SENSOR

< DTC/CIRCUIT DIAGNOSIS >

[VQ37VHR FOR USA AND CANADA]

## P1239, P2135 TP SENSOR

### DTC Logic

INFOID:000000006883078

#### DTC DETECTION LOGIC

##### NOTE:

If DTC P1239 or P2135 is displayed with DTC P0643, first perform the trouble diagnosis for DTC P0643. Refer to [EC-388, "DTC Logic"](#).

| DTC No. | Trouble diagnosis name                                      | DTC detecting condition   | Possible cause   |
|---------|---|---|--|
| P1239   | Throttle position sensor (bank 2) circuit range/performance | Rationally incorrect voltage is sent to ECM compared with the signals from TP sensor 1 and TP sensor 2. | <ul style="list-style-type: none"> <li>Harness or connector (TP sensor 1 or 2 circuit is open or shorted.)</li> <li>Electric throttle control actuator (TP sensor 1 or 2)</li> </ul> |
| P2135   | Throttle position sensor (bank 1) circuit range/performance |   |  |

#### DTC CONFIRMATION PROCEDURE

##### 1. PRECONDITIONING

If DTC Confirmation Procedure has been previously conducted, always perform the following procedure before conducting the next test.

- Turn ignition switch OFF and wait at least 10 seconds.
- Turn ignition switch ON.
- Turn ignition switch OFF and wait at least 10 seconds.

##### TESTING CONDITION:

Before performing the following procedure, confirm that battery voltage is more than 10 V at idle.

>> GO TO 2.

##### 2. PERFORM DTC CONFIRMATION PROCEDURE

- Start engine and let it idle for 1 second.
- Check DTC.

Is DTC detected?

- YES >> Go to [EC-429, "Diagnosis Procedure"](#).  
 NO >> INSPECTION END

#### Diagnosis Procedure

INFOID:000000006883079

##### 1. CHECK GROUND CONNECTION

- Turn ignition switch OFF.
- Check ground connection M95. Refer to Ground Inspection in [GI-47, "Circuit Inspection"](#).

Is the inspection result normal?

- YES >> GO TO 2.  
 NO >> Repair or replace ground connection.

##### 2. CHECK THROTTLE POSITION SENSOR POWER SUPPLY CIRCUIT-I

- Disconnect electric throttle control actuator harness connector.
- Turn ignition switch ON.
- Check the voltage between electric throttle control actuator harness connector and ground.

| DTC   | Electric throttle control actuator |           |          | Ground | Voltage (V) |
|-------|------------------------------------|-----------|----------|--------|-------------|
|       | Bank                               | Connector | Terminal |        |             |
| P1239 | 2                                  | F27       | 1        | Ground | Approx. 5   |
| P2135 | 1                                  | F67       | 6        |        |             |

Is the inspection result normal?

- YES >> GO TO 3.  
 NO >> Repair open circuit, short to ground or short to power in harness or connectors.

# P1239, P2135 TP SENSOR

< DTC/CIRCUIT DIAGNOSIS >

[VQ37VHR FOR USA AND CANADA]

## 3. CHECK THROTTLE POSITION SENSOR GROUND CIRCUIT FOR OPEN AND SHORT

1. Turn ignition switch OFF.
2. Disconnect ECM harness connector.
3. Check the continuity between electric throttle control actuator harness connector and ECM harness connector.

| DTC   | Electric throttle control actuator |           |          | ECM       |          | Continuity |
|-------|------------------------------------|-----------|----------|-----------|----------|------------|
|       | Bank                               | Connector | Terminal | Connector | Terminal |            |
| P1239 | 2                                  | F27       | 4        | F101      | 48       | Existed    |
| P2135 | 1                                  | F67       | 3        |           | 40       |            |

4. Also check harness for short to ground and short to power.

Is the inspection result normal?

YES >> GO TO 4.

NO >> Repair open circuit, short to ground or short to power in harness or connectors.

## 4. CHECK THROTTLE POSITION SENSOR INPUT SIGNAL CIRCUIT FOR OPEN AND SHORT

1. Check the continuity between electric throttle control actuator harness connector and ECM harness connector.

| DTC   | Electric throttle control actuator |           |          | ECM       |          | Continuity |
|-------|------------------------------------|-----------|----------|-----------|----------|------------|
|       | Bank                               | Connector | Terminal | Connector | Terminal |            |
| P1239 | 2                                  | F27       | 2        | F101      | 31       | Existed    |
|       |                                    |           | 3        |           | 35       |            |
| P2135 | 1                                  | F67       | 4        |           | 30       |            |
|       |                                    |           | 5        |           | 34       |            |

2. Also check harness for short to ground and short to power.

Is the inspection result normal?

YES >> GO TO 5.

NO >> Repair open circuit, short to ground or short to power in harness or connectors.

## 5. CHECK THROTTLE POSITION SENSOR

Refer to [EC-430, "Component Inspection"](#).

Is the inspection result normal?

YES >> GO TO 7.

NO >> GO TO 6.

## 6. REPLACE ELECTRIC THROTTLE CONTROL ACTUATOR

1. Replace malfunctioning electric throttle control actuator.
2. [EC-431, "Special Repair Requirement"](#).

>> INSPECTION END

## 7. CHECK INTERMITTENT INCIDENT

Refer to [GI-44, "Intermittent Incident"](#).

>> INSPECTION END

## Component Inspection

INFOID:000000006883080

## 1. CHECK THROTTLE POSITION SENSOR

1. Turn ignition switch OFF.
2. Reconnect all harness connectors disconnected.
3. Perform [EC-148, "Work Procedure"](#).

# P1239, P2135 TP SENSOR

[VQ37VHR FOR USA AND CANADA]

< DTC/CIRCUIT DIAGNOSIS >

4. Turn ignition switch ON.
5. Set selector lever to D position.
6. Check the voltage between ECM harness connector terminals as per the following.

| ECM       |                           |          | Condition       | Voltage (V)    |
|-----------|---------------------------|----------|-----------------|----------------|
| Connector | +                         | -        |                 |                |
|           | Terminal                  | Terminal |                 |                |
| F101      | 30 [TP sensor 1 (bank 1)] | 40       | Fully released  | More than 0.36 |
|           |                           |          | Fully depressed | Less than 4.75 |
|           | 31 [TP sensor 1 (bank 2)] | 48       | Fully released  | More than 0.36 |
|           |                           |          | Fully depressed | Less than 4.75 |
|           | 34 [TP sensor 2 (bank 1)] | 40       | Fully released  | Less than 4.75 |
|           |                           |          | Fully depressed | More than 0.36 |
|           | 35 [TP sensor 2 (bank 2)] | 48       | Fully released  | Less than 4.75 |
|           |                           |          | Fully depressed | More than 0.36 |

Is the inspection result normal?

YES >> INSPECTION END

NO >> GO TO 2.

## 2. REPLACE ELECTRIC THROTTLE CONTROL ACTUATOR

1. Replace malfunctioning electric throttle control actuator.
2. Go to [EC-431. "Special Repair Requirement"](#).

>> INSPECTION END

## Special Repair Requirement

INFOID:000000006883081

## 1. PERFORM THROTTLE VALVE CLOSED POSITION LEARNING

Refer to [EC-148. "Work Procedure"](#)

>> GO TO 2.

## 2. PERFORM IDLE AIR VOLUME LEARNING

Refer to [EC-149. "Work Procedure"](#)

>> END

# P1290, P2100, P2103 THROTTLE CONTROL MOTOR RELAY

< DTC/CIRCUIT DIAGNOSIS >

[VQ37VHR FOR USA AND CANADA]

## P1290, P2100, P2103 THROTTLE CONTROL MOTOR RELAY

### DTC Logic

INFOID:000000006883082

### DTC DETECTION LOGIC

| DTC No. | Trouble diagnosis name                             | DTC detecting condition  | Possible cause   |
|---------|--|--|--|
| P1290   | Throttle control motor relay circuit open (bank 2) | ECM detects a voltage of power source for throttle control motor is excessively low. | <ul style="list-style-type: none"><li>• Harness or connectors (Throttle control motor relay circuit is open)</li><li>• Throttle control motor relay</li></ul>    |
| P2100   | Throttle control motor relay circuit open (bank 1) |  |  |
| P2103   | Throttle control motor relay circuit short         | ECM detect the throttle control motor relay is stuck ON.                             | <ul style="list-style-type: none"><li>• Harness or connectors (Throttle control motor relay circuit is shorted)</li><li>• Throttle control motor relay</li></ul> |

### DTC CONFIRMATION PROCEDURE

#### 1. PRECONDITIONING

If DTC Confirmation Procedure has been previously conducted, always perform the following procedure before conducting the next test.

1. Turn ignition switch OFF and wait at least 10 seconds.
2. Turn ignition switch ON.
3. Turn ignition switch OFF and wait at least 10 seconds.

#### TESTING CONDITION:

**Before performing the following procedure, confirm that battery voltage is more than 8 V.**

Which DTC is detected?

P1290, P2100 >> GO TO 2.

P2103 >> GO TO 3.

#### 2. PERFORM DTC CONFIRMATION PROCEDURE FOR DTC P1290 AND P2100

1. Turn ignition switch ON and wait at least 2 seconds.
2. Start engine and let it idle for 5 seconds.
3. Check DTC.

Is DTC detected?

YES >> Go to [EC-432, "Diagnosis Procedure"](#).

NO >> INSPECTION END

#### 3. PERFORM DTC CONFIRMATION PROCEDURE FOR DTC P2103

1. Turn ignition switch ON and wait at least 1 second.
2. Check DTC.

Is DTC detected?

YES >> Go to [EC-432, "Diagnosis Procedure"](#).

NO >> INSPECTION END

### Diagnosis Procedure

INFOID:000000006883083

#### 1. CHECK THROTTLE CONTROL MOTOR RELAY POWER SUPPLY CIRCUIT

1. Turn ignition switch OFF.
2. Disconnect ECM harness connector.
3. Disconnect IPDM E/R harness connector E7.
4. Check the continuity between IPDM E/R harness connector and ECM harness connector.

| IPDM E/R  |          | ECM       |          | Continuity |
|-----------|----------|-----------|----------|------------|
| Connector | Terminal | Connector | Terminal |            |
| E7        | 71       | F101      | 25       | Existed    |

5. Also check harness for short to ground and short to power.



# P1290, P2100, P2103 THROTTLE CONTROL MOTOR RELAY

< DTC/CIRCUIT DIAGNOSIS >

[VQ37VHR FOR USA AND CANADA]

Is the inspection result normal?

YES >> GO TO 3.

NO >> GO TO 2.

## 2. DETECT MALFUNCTIONING PART

Check the following.

- Harness connectors E20, F40
- Harness for open or short between ECM and IPDM E/R

>> Repair open circuit, short to ground or short to power in harness or connectors.

## 3. CHECK THROTTLE CONTROL MOTOR RELAY INPUT SIGNAL CIRCUIT

1. Check the continuity between IPDM E/R sensor harness connector and ECM harness connector.

| DTC   | IPDM E/R  |          | ECM       |          | Continuity |
|-------|-----------|----------|-----------|----------|------------|
|       | Connector | Terminal | Connector | Terminal |            |
| P1290 | E5        | 7        | F102      | 52       | Existed    |
| P2100 |           |          | F101      | 3        |            |
| P2103 |           |          | F101      | 3        |            |
|       |           |          | F102      | 52       |            |

2. Also check harness for short to ground and short to power.

Is the inspection result normal?

YES >> GO TO 5.

NO >> GO TO 4.

## 4. DETECT MALFUNCTIONING PART

Check the following.

- Harness connectors E20, F40
- Harness for open or short between ECM and IPDM E/R

>> Repair open circuit, short to ground or short to power in harness or connectors.

## 5. CHECK FUSE

1. Disconnect 15 A fuse (No. 50) from IPDM E/R.
2. Check 15 A fuse for blown.

Is the inspection result normal?

YES >> GO TO 6.

NO >> Replace 15A fuse.

## 6. CHECK INTERMITTENT INCIDENT

Refer to [GI-44, "Intermittent Incident"](#).

Is the inspection result normal?

YES >> Replace IPDM E/R. Refer to [PCS-33, "Exploded View"](#).

NO >> Repair or replace harness or connectors.

A  
EC  
C  
D  
E  
F  
G  
H  
I  
J  
K  
L  
M  
N  
O  
P

# P1550 BATTERY CURRENT SENSOR

< DTC/CIRCUIT DIAGNOSIS >

[VQ37VHR FOR USA AND CANADA]

## P1550 BATTERY CURRENT SENSOR

### DTC Logic

INFOID:000000006883087

### DTC DETECTION LOGIC

| DTC No. | Trouble diagnosis name                           | DTC detecting condition  | Possible cause   |
|---------|--|--|--|
| P1550   | Battery current sensor circuit range/performance | The output voltage of the battery current sensor remains within the specified range while engine is running. | <ul style="list-style-type: none"><li>• Harness or connectors<br/>(Battery current sensor circuit is open or shorted.)<br/>[CKP sensor (POS) circuit is open or shorted.]<br/>[CMP sensor (PHASE) (bank 2) circuit is open or shorted.]<br/>(APP sensor 2 circuit is shorted.)<br/>(EVAP control system pressure sensor circuit is shorted.)<br/>(Refrigerant pressure sensor circuit is shorted.)</li><li>• Battery current sensor</li><li>• Crankshaft position sensor (POS)</li><li>• Camshaft position sensor (PHASE) (bank 2)</li><li>• Accelerator pedal position sensor</li><li>• EVAP control system pressure sensor</li><li>• Refrigerant pressure sensor</li></ul> |

### DTC CONFIRMATION PROCEDURE

#### 1. PRECONDITIONING

If DTC Confirmation Procedure has been previously conducted, always perform the following procedure before conducting the next test.

1. Turn ignition switch OFF and wait at least 10 seconds.
2. Turn ignition switch ON.
3. Turn ignition switch OFF and wait at least 10 seconds.

#### TESTING CONDITION:

Before performing the following procedure, confirm that battery voltage is more than 8 V at idle.

>> GO TO 2.

#### 2. PERFORM DTC CONFIRMATION PROCEDURE

1. Start engine and wait at least 10 seconds.
2. Check 1st trip DTC.

Is 1st trip DTC detected?

YES >> Go to [EC-434, "Diagnosis Procedure"](#).

NO >> INSPECTION END

### Diagnosis Procedure

INFOID:000000006883088

#### 1. CHECK GROUND CONNECTION

1. Turn ignition switch OFF.
2. Check ground connection M95. Refer to Ground Inspection in [GI-47, "Circuit Inspection"](#).

Is the inspection result normal?

YES >> GO TO 2.

NO >> Repair or replace ground connection.

#### 2. CHECK BATTERY CURRENT SENSOR POWER SUPPLY CIRCUIT-I

1. Disconnect battery current sensor harness connector.
2. Turn ignition switch ON.
3. Check the voltage between battery current sensor harness connector and ground.

| Battery current sensor |          | Ground | Voltage (V) |
|------------------------|----------|--------|-------------|
| Connector              | Terminal |        |             |
| E21                    | 1        | Ground | Approx. 5   |

# P1550 BATTERY CURRENT SENSOR

[VQ37VHR FOR USA AND CANADA]

## < DTC/CIRCUIT DIAGNOSIS >

Is the inspection result normal?

YES >> GO TO 9.

NO >> GO TO 3.

### 3.CHECK BATTERY CURRENT SENSOR POWER SUPPLY CIRCUIT-II

1. Turn ignition switch OFF.
2. Disconnect ECM harness connector.
3. Check the continuity between battery current sensor harness connector and ECM harness connector.

| Battery current sensor |          | ECM       |          | Continuity |
|------------------------|----------|-----------|----------|------------|
| Connector              | Terminal | Connector | Terminal |            |
| E21                    | 1        | F102      | 64       | Existed    |

Is the inspection result normal?

YES >> GO TO 5.

NO >> GO TO 4.

### 4.DETECT MALFUNCTIONING PART

Check the following.

- Harness connectors F40, E20
- Harness for open between battery current sensor and ECM

>> Repair open circuit.

### 5.CHECK SENSOR POWER SUPPLY CIRCUIT

Check harness for short to power and short to ground, between the following terminals.

| ECM       |          | Sensor                              |  |                                    |
|-----------|----------|-------------------------------------|--|------------------------------------|
| Connector | Terminal | Name                                | Connector                              | Terminal                           |
| F101      | 46       | CKP sensor (POS)                    | F2                                     | 1                                  |
| F102      | 64       | CMP sensor (PHASE) (bank 2)         | F18                                    | 1                                  |
|           |          | Battery current sensor              | E21                                    |                                    |
| M107      | 103      | APP sensor                          | M153 <sup>*1</sup><br>M9 <sup>*2</sup> | 3 <sup>*1</sup><br>6 <sup>*2</sup> |
|           | 107      | EVAP control system pressure sensor | B73                                    | 3                                  |
|           |          | Refrigerant pressure sensor         | E77                                    | 3                                  |

\*1: With ICC

\*2: Without ICC

Is the inspection result normal?

YES >> GO TO 6.

NO >> Repair short to ground or short to power in harness or connectors.

### 6.CHECK COMPONENTS

Check the following.

- Crankshaft position sensor (POS) (Refer to [EC-314, "Component Inspection"](#).)
- Camshaft position sensor (PHASE) (bank 2) (Refer to [EC-319, "Component Inspection"](#).)
- EVAP control system pressure sensor (Refer to [EC-349, "Component Inspection"](#).)
- Refrigerant pressure sensor (Refer to [EC-530, "Diagnosis Procedure"](#).)

Is the inspection result normal?

YES >> GO TO 7.

NO >> Replace malfunctioning component.

### 7.CHECK APP SENSOR

Refer to [EC-437, "Component Inspection"](#).

Is the inspection result normal?

# P1550 BATTERY CURRENT SENSOR

[VQ37VHR FOR USA AND CANADA]

< DTC/CIRCUIT DIAGNOSIS >

- YES >> GO TO 14.  
NO >> GO TO 8.

## 8. REPLACE ACCELERATOR PEDAL ASSEMBLY

1. Replace accelerator pedal assembly.
2. Go to [EC-487. "Special Repair Requirement"](#).

>> INSPECTION END

## 9. CHECK BATTERY CURRENT SENSOR GROUND CIRCUIT FOR OPEN AND SHORT

1. Turn ignition switch OFF.
2. Disconnect ECM harness connector.
3. Check the continuity between battery current sensor harness connector and ECM harness connector.

| Battery current sensor |          | ECM       |          | Continuity |
|------------------------|----------|-----------|----------|------------|
| Connector              | Terminal | Connector | Terminal |            |
| E21                    | 3        | F102      | 95       | Existed    |

4. Also check harness for short to ground and short to power.

Is the inspection result normal?

- YES >> GO TO 11.  
NO >> GO TO 10.

## 10. DETECT MALFUNCTIONING PART

Check the following.

- Harness connectors E20, F40
- Harness for open or short between battery current sensor and ECM

>> Repair open circuit, short to ground or short to power in harness or connectors.

## 11. CHECK BATTERY CURRENT SENSOR INPUT SIGNAL CIRCUIT FOR OPEN AND SHORT

1. Check the continuity between battery current sensor harness connector and ECM harness connector.

| Battery current sensor |          | ECM       |          | Continuity |
|------------------------|----------|-----------|----------|------------|
| Connector              | Terminal | Connector | Terminal |            |
| E21                    | 4        | F102      | 91       | Existed    |

2. Also check harness for short to ground and short to power.

Is the inspection result normal?

- YES >> GO TO 13.  
NO >> GO TO 12.

## 12. DETECT MALFUNCTIONING PART

Check the following.

- Harness connectors E20, F40
- Harness for open or short between battery current sensor and ECM

>> Repair open circuit, short to ground or short to power in harness or connectors.

## 13. CHECK BATTERY CURRENT SENSOR

Refer to [EC-437. "Component Inspection"](#).

Is the inspection result normal?

- YES >> GO TO 14.  
NO >> Replace battery negative cable assembly.

## 14. CHECK INTERMITTENT INCIDENT

Refer to [GI-44. "Intermittent Incident"](#).

# P1550 BATTERY CURRENT SENSOR

< DTC/CIRCUIT DIAGNOSIS >

[VQ37VHR FOR USA AND CANADA]

>> INSPECTION END

## Component Inspection

INFOID:000000006883089

### 1. CHECK BATTERY CURRENT SENSOR

1. Turn ignition switch OFF.
2. Reconnect harness connectors disconnected.
3. Disconnect battery negative cable (1).

←: To body ground

4. Install jumper cable (A) between battery negative terminal and body ground.
5. Turn ignition switch ON.
6. Check the voltage between ECM harness connector terminals as per the following.

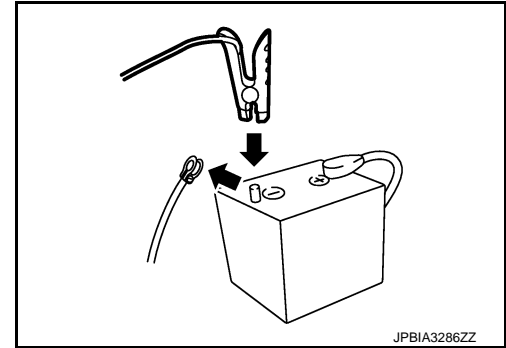

| ECM       |                                       |          | Voltage (V) |
|-----------|---------------------------------------|----------|-------------|
| Connector | +                                     | -        |             |
|           | Terminal                              | Terminal |             |
| F102      | 91<br>(Battery current sensor signal) | 95       | Approx. 2.5 |

Before measuring the terminal voltage, confirm that the battery is fully charged. Refer to [PG-135, "How to Handle Battery"](#).

Is the inspection result normal?

- YES >> INSPECTION END  
NO >> Replace battery negative cable assembly.

# P1551, P1552 BATTERY CURRENT SENSOR

< DTC/CIRCUIT DIAGNOSIS >

[VQ37VHR FOR USA AND CANADA]

## P1551, P1552 BATTERY CURRENT SENSOR

### DTC Logic

INFOID:000000006883090

### DTC DETECTION LOGIC

| DTC No. | Trouble diagnosis name                    | DTC detecting condition                                     | Possible cause   |
|---------|---|---|--|
| P1551   | Battery current sensor circuit low input  | An excessively low voltage from the sensor is sent to ECM.  | <ul style="list-style-type: none"><li>• Harness or connectors (Battery current sensor circuit is open or shorted.) [CKP sensor (POS) circuit is open or shorted.] [CMP sensor (PHASE) (bank 2) circuit is open or shorted.] [APP sensor 2 circuit is shorted.] (EVAP control system pressure sensor circuit is shorted.) (Refrigerant pressure sensor circuit is shorted.)</li><li>• Battery current sensor</li><li>• Crankshaft position sensor (POS)</li><li>• Camshaft position sensor (PHASE) (bank 2)</li><li>• Accelerator pedal position sensor</li><li>• EVAP control system pressure sensor</li><li>• Refrigerant pressure sensor</li></ul> |
| P1552   | Battery current sensor circuit high input | An excessively high voltage from the sensor is sent to ECM. |  |

### DTC CONFIRMATION PROCEDURE

#### 1. PRECONDITIONING

If DTC Confirmation Procedure has been previously conducted, always perform the following procedure before conducting the next test.

1. Turn ignition switch OFF and wait at least 10 seconds.
2. Turn ignition switch ON.
3. Turn ignition switch OFF and wait at least 10 seconds.

#### TESTING CONDITION:

**Before performing the following procedure, confirm that battery voltage is more than 8 V with ignition switch ON**

>> GO TO 2.

#### 2. PERFORM DTC CONFIRMATION PROCEDURE

1. Turn ignition switch ON and wait at least 10 seconds.
2. Check 1st trip DTC.

Is 1st trip DTC detected?

- YES >> Go to [EC-438, "Diagnosis Procedure"](#).  
NO >> INSPECTION END

### Diagnosis Procedure

INFOID:000000006883091

#### 1. CHECK GROUND CONNECTION

1. Turn ignition switch OFF.
2. Check ground connection M95. Refer to Ground Inspection in [GI-47, "Circuit Inspection"](#).

Is the inspection result normal?

- YES >> GO TO 2.  
NO >> Repair or replace ground connection.

#### 2. CHECK BATTERY CURRENT SENSOR POWER SUPPLY CIRCUIT-I

1. Disconnect battery current sensor harness connector.
2. Turn ignition switch ON.
3. Check the voltage between battery current sensor harness connector and ground.

# P1551, P1552 BATTERY CURRENT SENSOR

< DTC/CIRCUIT DIAGNOSIS >

[VQ37VHR FOR USA AND CANADA]

| Battery current sensor |          | Ground | Voltage (V) |
|------------------------|----------|--------|-------------|
| Connector              | Terminal |        |             |
| E21                    | 1        | Ground | Approx. 5   |

Is the inspection result normal?

YES >> GO TO 9.

NO >> GO TO 3.

## 3. CHECK BATTERY CURRENT SENSOR POWER SUPPLY CIRCUIT-II

1. Turn ignition switch OFF.
2. Disconnect ECM harness connector.
3. Check the continuity between battery current sensor harness connector and ECM harness connector.

| Battery current sensor |          | ECM       |          | Continuity |
|------------------------|----------|-----------|----------|------------|
| Connector              | Terminal | Connector | Terminal |            |
| E21                    | 1        | F102      | 64       | Existed    |

Is the inspection result normal?

YES >> GO TO 5.

NO >> GO TO 4.

## 4. DETECT MALFUNCTIONING PART

Check the following.

- Harness connectors F40, E20
- Harness for open between battery current sensor and ECM

>> Repair open circuit.

## 5. CHECK SENSOR POWER SUPPLY CIRCUIT

Check harness for short to power and short to ground, between the following terminals.

| ECM       |          | Sensor                              |  |                                    |
|-----------|----------|-------------------------------------|--|------------------------------------|
| Connector | Terminal | Name                                | Connector                              | Terminal                           |
| F101      | 46       | CKP sensor (POS)                    | F2                                     | 1                                  |
| F102      | 64       | CMP sensor (PHASE) (bank 2)         | F18                                    | 1                                  |
|           |          | Battery current sensor              | E21                                    |                                    |
| M107      | 103      | APP sensor                          | M153 <sup>*1</sup><br>M9 <sup>*2</sup> | 3 <sup>*1</sup><br>6 <sup>*2</sup> |
|           |          | EVAP control system pressure sensor | B73                                    | 3                                  |
|           | 107      | Refrigerant pressure sensor         | E77                                    | 3                                  |

\*1: With ICC

\*2: Without ICC

Is the inspection result normal?

YES >> GO TO 6.

NO >> Repair short to ground or short to power in harness or connectors.

## 6. CHECK COMPONENTS

Check the following.

- Crankshaft position sensor (POS) (Refer to [EC-314, "Component Inspection"](#).)
- Camshaft position sensor (PHASE) (bank 2) (Refer to [EC-319, "Component Inspection"](#).)
- EVAP control system pressure sensor (Refer to [EC-349, "Component Inspection"](#).)
- Refrigerant pressure sensor (Refer to [EC-530, "Diagnosis Procedure"](#).)

Is the inspection result normal?

# P1551, P1552 BATTERY CURRENT SENSOR

[VQ37VHR FOR USA AND CANADA]

## < DTC/CIRCUIT DIAGNOSIS >

- YES >> GO TO 7.  
NO >> Replace malfunctioning component.

### 7. CHECK APP SENSOR

Refer to [EC-449, "Component Inspection"](#).

Is the inspection result normal?

- YES >> GO TO 14.  
NO >> GO TO 8.

### 8. REPLACE ACCELERATOR PEDAL ASSEMBLY

1. Replace accelerator pedal assembly.
2. Go to [EC-487, "Special Repair Requirement"](#).

>> INSPECTION END

### 9. CHECK BATTERY CURRENT SENSOR GROUND CIRCUIT FOR OPEN AND SHORT

1. Turn ignition switch OFF.
2. Disconnect ECM harness connector.
3. Check the continuity between battery current sensor harness connector and ECM harness connector.

| Battery current sensor |          | ECM       |          | Continuity |
|------------------------|----------|-----------|----------|------------|
| Connector              | Terminal | Connector | Terminal |            |
| E21                    | 3        | F102      | 95       | Existed    |

4. Also check harness for short to ground and short to power.

Is the inspection result normal?

- YES >> GO TO 11.  
NO >> GO TO 10.

### 10. DETECT MALFUNCTIONING PART

Check the following.

- Harness connectors E20, F40
- Harness for open or short between battery current sensor and ECM

>> Repair open circuit, short to ground or short to power in harness or connectors.

### 11. CHECK BATTERY CURRENT SENSOR INPUT SIGNAL CIRCUIT FOR OPEN AND SHORT

1. Check the continuity between battery current sensor harness connector and ECM harness connector.

| Battery current sensor |          | ECM       |          | Continuity |
|------------------------|----------|-----------|----------|------------|
| Connector              | Terminal | Connector | Terminal |            |
| E21                    | 4        | F102      | 91       | Existed    |

2. Also check harness for short to ground and short to power.

Is the inspection result normal?

- YES >> GO TO 13.  
NO >> GO TO 12.

### 12. DETECT MALFUNCTIONING PART

Check the following.

- Harness connectors E20, F40
- Harness for open or short between battery current sensor and ECM

>> Repair open circuit, short to ground or short to power in harness or connectors.

### 13. CHECK BATTERY CURRENT SENSOR

Refer to [EC-449, "Component Inspection"](#).



# P1551, P1552 BATTERY CURRENT SENSOR

[VQ37VHR FOR USA AND CANADA]

< DTC/CIRCUIT DIAGNOSIS >

Is the inspection result normal?

- YES >> GO TO 14.
- NO >> Replace battery negative cable assembly.

## 14. CHECK INTERMITTENT INCIDENT

Refer to [GI-44. "Intermittent Incident"](#).

>> INSPECTION END

## Component Inspection

INFOID:000000006883092

### 1. CHECK BATTERY CURRENT SENSOR

1. Turn ignition switch OFF.
2. Reconnect harness connectors disconnected.
3. Disconnect battery negative cable (1).

←: To body ground

4. Install jumper cable (A) between battery negative terminal and body ground.
5. Turn ignition switch ON.
6. Check the voltage between ECM harness connector terminals as per the following.

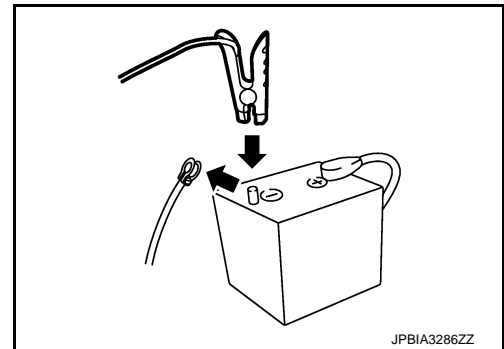

| ECM       |                                       |          | Voltage (V) |
|-----------|---------------------------------------|----------|-------------|
| Connector | +                                     | -        |             |
|           | Terminal                              | Terminal |             |
| F102      | 91<br>(Battery current sensor signal) | 95       | Approx. 2.5 |

Before measuring the terminal voltage, confirm that the battery is fully charged. Refer to [PG-135. "How to Handle Battery"](#).

Is the inspection result normal?

- YES >> INSPECTION END
- NO >> Replace battery negative cable assembly.

# P1553 BATTERY CURRENT SENSOR

< DTC/CIRCUIT DIAGNOSIS >

[VQ37VHR FOR USA AND CANADA]

## P1553 BATTERY CURRENT SENSOR

### DTC Logic

INFOID:000000006883093

### DTC DETECTION LOGIC

| DTC No. | Trouble diagnosis name             | DTC detecting condition  | Possible cause   |
|---------|------------------------------------|--|--|
| P1553   | Battery current sensor performance | The signal voltage transmitted from the sensor to ECM is higher than the amount of the maximum power generation. | <ul style="list-style-type: none"> <li>• Harness or connectors<br/>(Battery current sensor circuit is open or shorted.)<br/>[CKP sensor (POS) circuit is open or shorted.]<br/>[CMP sensor (PHASE) (bank 2) circuit is open or shorted.]<br/>(APP sensor 2 circuit is shorted.)<br/>(EVAP control system pressure sensor circuit is shorted.)<br/>(Refrigerant pressure sensor circuit is shorted.)</li> <li>• Battery current sensor</li> <li>• Crankshaft position sensor (POS)</li> <li>• Camshaft position sensor (PHASE) (bank 2)</li> <li>• Accelerator pedal position sensor</li> <li>• EVAP control system pressure sensor</li> <li>• Refrigerant pressure sensor</li> </ul> |

### DTC CONFIRMATION PROCEDURE

#### 1. PRECONDITIONING

If DTC Confirmation Procedure has been previously conducted, always perform the following procedure before conducting the next test.

1. Turn ignition switch OFF and wait at least 10 seconds.
2. Turn ignition switch ON.
3. Turn ignition switch OFF and wait at least 10 seconds.

#### TESTING CONDITION:

Before performing the following procedure, confirm that battery voltage is more than 8 V at idle.

>> GO TO 2.

#### 2. PERFORM DTC CONFIRMATION PROCEDURE

1. Start engine and wait at least 10 seconds.
2. Check 1st trip DTC.

Is 1st trip DTC detected?

YES >> Go to [EC-442, "Diagnosis Procedure"](#).

NO >> INSPECTION END

### Diagnosis Procedure

INFOID:000000006883094

#### 1. CHECK GROUND CONNECTION

1. Turn ignition switch OFF.
2. Check ground connection M95. Refer to Ground Inspection in [GI-47, "Circuit Inspection"](#).

Is the inspection result normal?

YES >> GO TO 2.

NO >> Repair or replace ground connection.

#### 2. CHECK BATTERY CURRENT SENSOR POWER SUPPLY CIRCUIT-I

1. Disconnect battery current sensor harness connector.
2. Turn ignition switch ON.
3. Check the voltage between battery current sensor harness connector and ground.

| Battery current sensor |          | Ground | Voltage (V) |
|------------------------|----------|--------|-------------|
| Connector              | Terminal |        |             |
| E21                    | 1        | Ground | Approx. 5   |

# P1553 BATTERY CURRENT SENSOR

[VQ37VHR FOR USA AND CANADA]

## < DTC/CIRCUIT DIAGNOSIS >

Is the inspection result normal?

YES >> GO TO 9.

NO >> GO TO 3.

### 3.CHECK BATTERY CURRENT SENSOR POWER SUPPLY CIRCUIT-II

1. Turn ignition switch OFF.
2. Disconnect ECM harness connector.
3. Check the continuity between battery current sensor harness connector and ECM harness connector.

| Battery current sensor |          | ECM       |          | Continuity |
|------------------------|----------|-----------|----------|------------|
| Connector              | Terminal | Connector | Terminal |            |
| E21                    | 1        | F102      | 64       | Existed    |

Is the inspection result normal?

YES >> GO TO 5.

NO >> GO TO 4.

### 4.DETECT MALFUNCTIONING PART

Check the following.

- Harness connectors F40, E20
- Harness for open between battery current sensor and ECM

>> Repair open circuit.

### 5.CHECK SENSOR POWER SUPPLY CIRCUIT

Check harness for short to power and short to ground, between the following terminals.

| ECM       |          | Sensor                              |  |                                    |
|-----------|----------|-------------------------------------|--|------------------------------------|
| Connector | Terminal | Name                                | Connector                              | Terminal                           |
| F101      | 46       | CKP sensor (POS)                    | F2                                     | 1                                  |
| F102      | 64       | CMP sensor (PHASE) (bank 2)         | F18                                    | 1                                  |
|           |          | Battery current sensor              | E21                                    |                                    |
| M107      | 103      | APP sensor                          | M153 <sup>*1</sup><br>M9 <sup>*2</sup> | 3 <sup>*1</sup><br>6 <sup>*2</sup> |
|           | 107      | EVAP control system pressure sensor | B73                                    | 3                                  |
|           |          | Refrigerant pressure sensor         | E77                                    | 3                                  |

\*1: With ICC

\*2: Without ICC

Is the inspection result normal?

YES >> GO TO 6.

NO >> Repair short to ground or short to power in harness or connectors.

### 6.CHECK COMPONENTS

Check the following.

- Crankshaft position sensor (POS) (Refer to [EC-314, "Component Inspection"](#).)
- Camshaft position sensor (PHASE) (bank 2) (Refer to [EC-319, "Component Inspection"](#).)
- EVAP control system pressure sensor (Refer to [EC-349, "Component Inspection"](#).)
- Refrigerant pressure sensor (Refer to [EC-530, "Diagnosis Procedure"](#).)

Is the inspection result normal?

YES >> GO TO 7.

NO >> Replace malfunctioning component.

### 7.CHECK APP SENSOR

Refer to [EC-449, "Component Inspection"](#).

Is the inspection result normal?

# P1553 BATTERY CURRENT SENSOR

[VQ37VHR FOR USA AND CANADA]

< DTC/CIRCUIT DIAGNOSIS >

- YES >> GO TO 14.  
NO >> GO TO 8.

## 8. REPLACE ACCELERATOR PEDAL ASSEMBLY

1. Replace accelerator pedal assembly.
2. Go to [EC-487. "Special Repair Requirement"](#).

>> INSPECTION END

## 9. CHECK BATTERY CURRENT SENSOR GROUND CIRCUIT FOR OPEN AND SHORT

1. Turn ignition switch OFF.
2. Disconnect ECM harness connector.
3. Check the continuity between battery current sensor harness connector and ECM harness connector.

| Battery current sensor |          | ECM       |          | Continuity |
|------------------------|----------|-----------|----------|------------|
| Connector              | Terminal | Connector | Terminal |            |
| E21                    | 3        | F102      | 95       | Existed    |

4. Also check harness for short to ground and short to power.

Is the inspection result normal?

- YES >> GO TO 11.  
NO >> GO TO 10.

## 10. DETECT MALFUNCTIONING PART

Check the following.

- Harness connectors E20, F40
- Harness for open or short between battery current sensor and ECM

>> Repair open circuit, short to ground or short to power in harness or connectors.

## 11. CHECK BATTERY CURRENT SENSOR INPUT SIGNAL CIRCUIT FOR OPEN AND SHORT

1. Check the continuity between battery current sensor harness connector and ECM harness connector.

| Battery current sensor |          | ECM       |          | Continuity |
|------------------------|----------|-----------|----------|------------|
| Connector              | Terminal | Connector | Terminal |            |
| E21                    | 4        | F102      | 91       | Existed    |

2. Also check harness for short to ground and short to power.

Is the inspection result normal?

- YES >> GO TO 13.  
NO >> GO TO 12.

## 12. DETECT MALFUNCTIONING PART

Check the following.

- Harness connectors E20, F40
- Harness for open or short between battery current sensor and ECM

>> Repair open circuit, short to ground or short to power in harness or connectors.

## 13. CHECK BATTERY CURRENT SENSOR

Refer to [EC-449. "Component Inspection"](#).

Is the inspection result normal?

- YES >> GO TO 14.  
NO >> Replace battery negative cable assembly.

## 14. CHECK INTERMITTENT INCIDENT

Refer to [GI-44. "Intermittent Incident"](#).

# P1553 BATTERY CURRENT SENSOR

< DTC/CIRCUIT DIAGNOSIS >

[VQ37VHR FOR USA AND CANADA]

>> INSPECTION END

## Component Inspection

INFOID:000000006883095

### 1. CHECK BATTERY CURRENT SENSOR

1. Turn ignition switch OFF.
2. Reconnect harness connectors disconnected.
3. Disconnect battery negative cable (1).

←: To body ground

4. Install jumper cable (A) between battery negative terminal and body ground.
5. Turn ignition switch ON.
6. Check the voltage between ECM harness connector terminals as per the following.

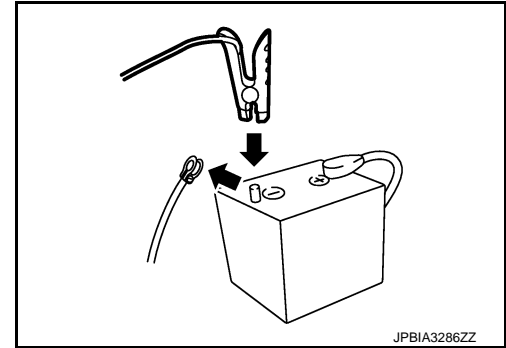

| ECM       |                                       |          | Voltage (V) |
|-----------|---------------------------------------|----------|-------------|
| Connector | +                                     | -        |             |
|           | Terminal                              | Terminal |             |
| F102      | 91<br>(Battery current sensor signal) | 95       | Approx. 2.5 |

Before measuring the terminal voltage, confirm that the battery is fully charged. Refer to [PG-135, "How to Handle Battery"](#).

Is the inspection result normal?

- YES >> INSPECTION END  
NO >> Replace battery negative cable assembly.

A  
EC  
C  
D  
E  
F  
G  
H  
I  
J  
K  
L  
M  
N  
O  
P

# P1554 BATTERY CURRENT SENSOR

< DTC/CIRCUIT DIAGNOSIS >

[VQ37VHR FOR USA AND CANADA]

## P1554 BATTERY CURRENT SENSOR

### DTC Logic

INFOID:000000006883096

### DTC DETECTION LOGIC

| DTC No. | Trouble diagnosis name             | DTC detecting condition  | Possible cause   |
|---------|------------------------------------|--|--|
| P1554   | Battery current sensor performance | The output voltage of the battery current sensor is lower than the specified value while the battery voltage is high enough. | <ul style="list-style-type: none"> <li>• Harness or connectors<br/>(Battery current sensor circuit is open or shorted.)<br/>[CKP sensor (POS) circuit is open or shorted.]<br/>[CMP sensor (PHASE) (bank 2) circuit is open or shorted.]<br/>(APP sensor 2 circuit is shorted.)<br/>(EVAP control system pressure sensor circuit is shorted.)<br/>(Refrigerant pressure sensor circuit is shorted.)</li> <li>• Battery current sensor</li> <li>• Crankshaft position sensor (POS)</li> <li>• Camshaft position sensor (PHASE) (bank 2)</li> <li>• Accelerator pedal position sensor</li> <li>• EVAP control system pressure sensor</li> <li>• Refrigerant pressure sensor</li> </ul> |

### DTC CONFIRMATION PROCEDURE

#### 1. PERFORM COMPONENT FUNCTION CHECK

Perform component function check. Refer to [EC-446, "Component Function Check"](#).

#### NOTE:

Use component function check to check the overall function of the battery current sensor circuit. During this check, a 1st trip DTC might not be confirmed.

Is the inspection result normal?

YES >> INSPECTION END

NO >> Go to [EC-447, "Diagnosis Procedure"](#).

### Component Function Check

INFOID:000000006883097

#### 1. PRECONDITIONING

#### TESTING CONDITION:

- Before performing the following procedure, confirm that battery voltage is more than 12.8 V at idle.
- Before performing the following procedure, confirm that all load switches and A/C switch are turned OFF.

>> GO TO 2.

#### 2. PERFORM COMPONENT FUNCTION CHECK

##### With CONSULT

1. Start engine and let it idle.
2. Select "BAT CUR SEN" in "DATA MONITOR" mode with CONSULT.
3. Check "BAT CUR SEN" indication for 10 seconds.  
"BAT CUR SEN" should be above 2,300 mV at least once.

##### Without CONSULT

1. Start engine and let it idle.
2. Check the voltage between ECM harness connector terminals as per the following.

| ECM       |                                       |          | Voltage (V)             |
|-----------|---------------------------------------|----------|-------------------------|
| Connector | +                                     | -        |                         |
|           | Terminal                              | Terminal |                         |
| F102      | 91<br>(Battery current sensor signal) | 95       | Above 2.3 at least once |

Is the inspection result normal?

# P1554 BATTERY CURRENT SENSOR

[VQ37VHR FOR USA AND CANADA]

< DTC/CIRCUIT DIAGNOSIS >

- YES >> INSPECTION END  
NO >> Go to [EC-447, "Diagnosis Procedure"](#)

## Diagnosis Procedure

INFOID:000000006883098

### 1. CHECK GROUND CONNECTION

1. Turn ignition switch OFF.
2. Check ground connection M95. Refer to Ground Inspection in [GI-47, "Circuit Inspection"](#).

Is the inspection result normal?

- YES >> GO TO 2.  
NO >> Repair or replace ground connection.

### 2. CHECK BATTERY CURRENT SENSOR POWER SUPPLY CIRCUIT-I

1. Disconnect battery current sensor harness connector.
2. Turn ignition switch ON.
3. Check the voltage between battery current sensor harness connector and ground.

| Battery current sensor |          | Ground | Voltage (V) |
|------------------------|----------|--------|-------------|
| Connector              | Terminal |        |             |
| E21                    | 1        | Ground | Approx. 5   |

Is the inspection result normal?

- YES >> GO TO 9.  
NO >> GO TO 3.

### 3. CHECK BATTERY CURRENT SENSOR POWER SUPPLY CIRCUIT-II

1. Turn ignition switch OFF.
2. Disconnect ECM harness connector.
3. Check the continuity between battery current sensor harness connector and ECM harness connector.

| Battery current sensor |          | ECM       |          | Continuity |
|------------------------|----------|-----------|----------|------------|
| Connector              | Terminal | Connector | Terminal |            |
| E21                    | 1        | F102      | 64       | Existed    |

Is the inspection result normal?

- YES >> GO TO 5.  
NO >> GO TO 4.

### 4. DETECT MALFUNCTIONING PART

Check the following.

- Harness connectors F40, E20
- Harness for open between battery current sensor and ECM

>> Repair open circuit.

### 5. CHECK SENSOR POWER SUPPLY CIRCUIT

Check harness for short to power and short to ground, between the following terminals.

| ECM       |          | Sensor                      |           |          |
|-----------|----------|-----------------------------|-----------|----------|
| Connector | Terminal | Name                        | Connector | Terminal |
| F101      | 46       | CKP sensor (POS)            | F2        | 1        |
| F102      | 64       | CMP sensor (PHASE) (bank 2) | F18       | 1        |
|           |          | Battery current sensor      | E21       |          |

# P1554 BATTERY CURRENT SENSOR

< DTC/CIRCUIT DIAGNOSIS >

[VQ37VHR FOR USA AND CANADA]

| ECM                         |          | Sensor                              |                    |                 |
|-----------------------------|----------|-------------------------------------|--------------------|-----------------|
| Connector                   | Terminal | Name                                | Connector          | Terminal        |
| M107                        | 103      | APP sensor                          | M153* <sup>1</sup> | 3* <sup>1</sup> |
|                             |          |                                     | M9* <sup>2</sup>   | 6* <sup>2</sup> |
|                             | 107      | EVAP control system pressure sensor | B73                | 3               |
| Refrigerant pressure sensor |          | E77                                 | 3                  |                 |

\*1: With ICC

\*2: Without ICC

Is the inspection result normal?

YES >> GO TO 6.

NO >> Repair short to ground or short to power in harness or connectors.

## 6. CHECK COMPONENTS

Check the following.

- Crankshaft position sensor (POS) (Refer to [EC-314, "Component Inspection"](#).)
- Camshaft position sensor (PHASE) (bank 2) (Refer to [EC-319, "Component Inspection"](#).)
- EVAP control system pressure sensor (Refer to [EC-349, "Component Inspection"](#).)
- Refrigerant pressure sensor (Refer to [EC-530, "Diagnosis Procedure"](#).)

Is the inspection result normal?

YES >> GO TO 7.

NO >> Replace malfunctioning component.

## 7. CHECK APP SENSOR

Refer to [EC-449, "Component Inspection"](#).

Is the inspection result normal?

YES >> GO TO 14.

NO >> GO TO 8.

## 8. REPLACE ACCELERATOR PEDAL ASSEMBLY

1. Replace accelerator pedal assembly.
2. Go to [EC-487, "Special Repair Requirement"](#).

>> INSPECTION END

## 9. CHECK BATTERY CURRENT SENSOR GROUND CIRCUIT FOR OPEN AND SHORT

1. Turn ignition switch OFF.
2. Disconnect ECM harness connector.
3. Check the continuity between battery current sensor harness connector and ECM harness connector.

| Battery current sensor |          | ECM       |          | Continuity |
|------------------------|----------|-----------|----------|------------|
| Connector              | Terminal | Connector | Terminal |            |
| E21                    | 3        | F102      | 95       | Existed    |

4. Also check harness for short to ground and short to power.

Is the inspection result normal?

YES >> GO TO 11.

NO >> GO TO 10.

## 10. DETECT MALFUNCTIONING PART

Check the following.

- Harness connectors E20, F40
- Harness for open or short between battery current sensor and ECM

>> Repair open circuit, short to ground or short to power in harness or connectors.



# P1554 BATTERY CURRENT SENSOR

[VQ37VHR FOR USA AND CANADA]

< DTC/CIRCUIT DIAGNOSIS >

## 11. CHECK BATTERY CURRENT SENSOR INPUT SIGNAL CIRCUIT FOR OPEN AND SHORT

1. Check the continuity between battery current sensor harness connector and ECM harness connector.

| Battery current sensor |          | ECM       |          | Continuity |
|------------------------|----------|-----------|----------|------------|
| Connector              | Terminal | Connector | Terminal |            |
| E21                    | 4        | F102      | 91       | Existed    |

2. Also check harness for short to ground and short to power.

Is the inspection result normal?

YES >> GO TO 13.

NO >> GO TO 12.

## 12. DETECT MALFUNCTIONING PART

Check the following.

- Harness connectors E20, F40
- Harness for open or short between battery current sensor and ECM

>> Repair open circuit, short to ground or short to power in harness or connectors.

## 13. CHECK BATTERY CURRENT SENSOR

Refer to [EC-449, "Component Inspection"](#).

Is the inspection result normal?

YES >> GO TO 14.

NO >> Replace battery negative cable assembly.

## 14. CHECK INTERMITTENT INCIDENT

Refer to [GI-44, "Intermittent Incident"](#).

>> INSPECTION END

## Component Inspection

INFOID:000000006883099

### 1. CHECK BATTERY CURRENT SENSOR

1. Turn ignition switch OFF.
2. Reconnect harness connectors disconnected.
3. Disconnect battery negative cable (1).

←: To body ground

4. Install jumper cable (A) between battery negative terminal and body ground.
5. Turn ignition switch ON.
6. Check the voltage between ECM harness connector terminals as per the following.

| Connector | ECM                                   |          | Voltage (V) |
|-----------|---------------------------------------|----------|-------------|
|           | +                                     | -        |             |
|           | Terminal                              | Terminal |             |
| F102      | 91<br>(Battery current sensor signal) | 95       | Approx. 2.5 |

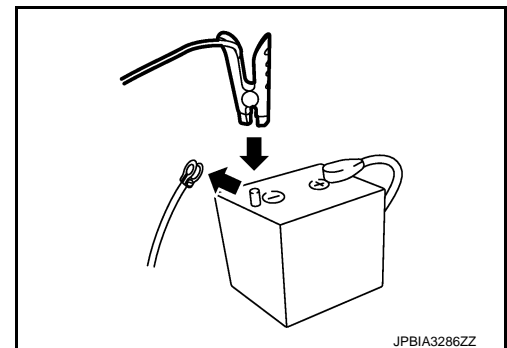

Before measuring the terminal voltage, confirm that the battery is fully charged. Refer to [PG-135, "How to Handle Battery"](#).

Is the inspection result normal?

YES >> INSPECTION END

NO >> Replace battery negative cable assembly.

# P1556, P1557 BATTERY TEMPERATURE SENSOR

< DTC/CIRCUIT DIAGNOSIS >

[VQ37VHR FOR USA AND CANADA]

## P1556, P1557 BATTERY TEMPERATURE SENSOR

### DTC Logic

INFOID:000000006883100

#### DTC DETECTION LOGIC

| DTC No. | Trouble diagnosis name<br>(Trouble diagnosis content)                  | DTC detecting condition  | Possible cause  |
|---------|--|--|---|
| P1556   | BAT TMP SEN/CIRC<br>(Battery temperature sensor<br>circuit low input)  | Signal voltage from Battery<br>temperature sensor remains<br>0.16V or less for 5 seconds or<br>more. | <ul style="list-style-type: none"><li>• Harness or connectors<br/>[Battery current sensor (Battery temperature sensor) circuit<br/>is shorted.]<br/>(Crankshaft position sensor circuit is open or shorted.)<br/>[Camshaft position sensor (bank 2) circuit is shorted.]<br/>(Accelerator pedal position sensor 2 circuit is shorted.)<br/>(EVAP control system pressure sensor circuit is shorted.)<br/>(Refrigerant pressure sensor circuit is shorted.)</li><li>• Battery current sensor (Battery temperature sensor)</li><li>• Crankshaft position sensor</li><li>• Camshaft position sensor (bank 2)</li><li>• Accelerator pedal position sensor 2</li><li>• EVAP control system pressure sensor</li><li>• Refrigerant pressure sensor</li></ul> |
| P1557   | BAT TMP SEN/CIRC<br>(Battery temperature sensor<br>circuit high input) | Signal voltage from Battery<br>temperature sensor remains<br>4.84V or more for 5 seconds<br>or more. |   |

#### DTC CONFIRMATION PROCEDURE

##### 1. PRECONDITIONING

Turn ignition switch OFF and wait at least 10 seconds.

>> GO TO 2.

##### 2. PERFORM DTC CONFIRMATION PROCEDURE

1. Start the engine and let it idle at least 10 seconds.
2. Check 1st trip DTC.

Is 1st trip DTC detected?

YES >> Proceed to [EC-450. "Diagnosis Procedure"](#).

NO >> INSPECTION END

#### Diagnosis Procedure

INFOID:000000006883101

##### 1. CHECK BATTERY TEMPERATURE SENSOR INPUT SIGNAL CIRCUIT-I

1. Disconnect battery current sensor harness connector.
2. Turn ignition switch ON.
3. Check the voltage between battery current sensor harness connector and ground.

| Battery current sensor |          | Ground | Voltage (V) |
|------------------------|----------|--------|-------------|
| Connector              | Terminal |        |             |
| E21                    | 2        | Ground | Approx. 5 V |

Is the inspection result normal?

YES >> GO TO 7.

NO >> GO TO 2.

##### 2. CHECK BATTERY TEMPERATURE SENSOR INPUT SIGNAL CIRCUIT-II

1. Turn ignition switch ON.
2. Disconnect ECM harness connector.
3. Check the continuity between battery current sensor harness connector and ECM harness connector.

# P1556, P1557 BATTERY TEMPERATURE SENSOR

< DTC/CIRCUIT DIAGNOSIS >

[VQ37VHR FOR USA AND CANADA]

| Battery current sensor |          | ECM       |          | Continuity |
|------------------------|----------|-----------|----------|------------|
| Connector              | Terminal | Connector | Terminal |            |
| E21                    | 2        | F102      | 83       | Existed    |

Is the inspection result normal?

YES >> GO TO 3.

NO >> Repair open circuit.

## 3. CHECK SENSOR POWER SUPPLY CIRCUIT

Check harness for short to power and short to ground, between the following terminals.

| ECM       |          | Sensor                              |  |                                    |
|-----------|----------|-------------------------------------|--|------------------------------------|
| Connector | Terminal | Name                                | Connector                              | Terminal                           |
| F101      | 46       | CKP sensor (POS)                    | F2                                     | 1                                  |
| F102      | 64       | CMP sensor (PHASE) (bank 2)         | F18                                    | 1                                  |
|           |          | Battery current sensor              | E21                                    |                                    |
| M107      | 103      | APP sensor                          | M153 <sup>*1</sup><br>M9 <sup>*2</sup> | 3 <sup>*1</sup><br>6 <sup>*2</sup> |
|           |          | EVAP control system pressure sensor | B73                                    | 3                                  |
|           | 107      | Refrigerant pressure sensor         | E77                                    | 3                                  |

\*1: With ICC

\*2: Without ICC

Is the inspection result normal?

YES >> GO TO 4.

NO >> Repair short to ground or short to power in harness or connectors.

## 4. CHECK COMPONENTS

Check the following.

- Camshaft position sensor (bank 2) (Refer to [EC-319, "Component Inspection"](#).)
- CKP sensor (Refer to [EC-314, "Component Inspection"](#).)
- Battery current sensor (Refer to [EC-437, "Component Inspection"](#).)
- EVAP control system pressure sensor (Refer to [EC-349, "Component Inspection"](#).)
- Refrigerant pressure sensor (Refer to [EC-530, "Diagnosis Procedure"](#).)

Is the inspection result normal?

YES >> GO TO 5.

NO >> Replace malfunctioning component.

## 5. CHECK APP SENSOR

Refer to [EC-487, "Component Inspection"](#).

Is the inspection result normal?

YES >> GO TO 9.

NO >> GO TO 6.

## 6. REPLACE ACCELERATOR PEDAL ASSEMBLY

Replace accelerator pedal assembly.

>> INSPECTION END

## 7. CHECK BATTERY TEMPERATURE SENSOR GROUND CIRCUIT FOR OPEN AND SHORT

1. Turn ignition switch OFF.
2. Disconnect ECM harness connector.
3. Check the continuity between battery current sensor harness connector and ECM harness connector.

# P1556, P1557 BATTERY TEMPERATURE SENSOR

< DTC/CIRCUIT DIAGNOSIS >

[VQ37VHR FOR USA AND CANADA]

| Battery current sensor |          | ECM       |          | Continuity |
|------------------------|----------|-----------|----------|------------|
| Connector              | Terminal | Connector | Terminal |            |
| E21                    | 3        | M160      | 150      | Existed    |

4. Also check harness for short to ground and short to power.

Is the inspection result normal?

YES >> GO TO 8.

NO >> Repair open circuit, short to ground or short to power in harness or connectors.

## 8.CHECK BATTERY TEMPERATURE SENSOR

Refer to [EC-452, "Component Inspection \(Battery Temperature Sensor\)"](#).

Is the inspection result normal?

YES >> GO TO 9.

NO >> Replace battery negative cable assembly.

## 9.CHECK INTERMITTENT INCIDENT

Refer to [GI-44, "Intermittent Incident"](#).

>> INSPECTION END

## Component Inspection (Battery Temperature Sensor)

INFOID:000000006883102

## 1.CHECK BATTERY TEMPERATURE SENSOR

1. Turn ignition switch OFF.
2. Disconnect battery current sensor.
3. Check the resistance between battery current sensor connector terminals.

| Battery current sensor |   | Resistance   |
|------------------------|---|--|
| +                      | - |  |
| Terminal               |   |  |
| 2                      | 3 | continuity with the resistance value 100 Ω or more |

Is the inspection result normal?

YES >> INSPECTION END

NO >> Replace battery negative cable assembly.

# P1564 ASCD STEERING SWITCH

< DTC/CIRCUIT DIAGNOSIS >

[VQ37VHR FOR USA AND CANADA]

## P1564 ASCD STEERING SWITCH

### DTC Logic

INFOID:000000006883103

### DTC DETECTION LOGIC

#### NOTE:

If DTC P1564 is displayed with DTC P0605, first perform the trouble diagnosis for DTC P0605. Refer to [EC-385, "DTC Logic"](#).

| DTC No. | Trouble diagnosis name | DTC detecting condition  | Possible cause  |
|---------|------------------------|--|---|
| P1564   | ASCD steering switch   | <ul style="list-style-type: none"><li>An excessively high voltage signal from the ASCD steering switch is sent to ECM.</li><li>ECM detects that input signal from the ASCD steering switch is out of the specified range.</li><li>ECM detects that the ASCD steering switch is stuck ON.</li></ul> | <ul style="list-style-type: none"><li>Harness or connectors (The switch circuit is open or shorted.)</li><li>ASCD steering switch</li><li>ECM</li></ul> |

### DTC CONFIRMATION PROCEDURE

#### 1. PRECONDITIONING

If DTC Confirmation Procedure has been previously conducted, always perform the following procedure before conducting the next test.

- Turn ignition switch OFF and wait at least 10 seconds.
- Turn ignition switch ON.
- Turn ignition switch OFF and wait at least 10 seconds.

>> GO TO 2.

#### 2. PERFORM DTC CONFIRMATION PROCEDURE

- Turn ignition switch ON and wait at least 10 seconds.
- Press MAIN switch for at least 10 seconds, then release it and wait at least 10 seconds.
- Press CANCEL switch for at least 10 seconds, then release it and wait at least 10 seconds.
- Press RESUME/ACCELERATE switch for at least 10 seconds, then release it and wait at least 10 seconds.
- Press SET/COAST switch for at least 10 seconds, then release it and wait at least 10 seconds.
- Check DTC.

Is DTC detected?

- YES >> Go to [EC-453, "Diagnosis Procedure"](#).  
NO >> INSPECTION END

### Diagnosis Procedure

INFOID:000000006883104

#### 1. CHECK GROUND CONNECTION

- Turn ignition switch OFF.
- Check ground connection M95. Refer to Ground Inspection in [GI-47, "Circuit Inspection"](#).

Is the inspection result normal?

- YES >> GO TO 2.  
NO >> Repair or replace ground connection.

#### 2. CHECK ASCD STEERING SWITCH CIRCUIT

##### With CONSULT

- Turn ignition switch ON.
- Select "MAIN SW", "CANCEL SW", "RESUME/ACC SW" and "SET SW" in "DATA MONITOR" mode with CONSULT.
- Check each item indication under the following conditions.

# P1564 ASCD STEERING SWITCH

< DTC/CIRCUIT DIAGNOSIS >

[VQ37VHR FOR USA AND CANADA]

| Monitor item  | Condition                |          | Indication |
|---------------|--------------------------|----------|------------|
| MAIN SW       | MAIN switch              | Pressed  | ON         |
|               |                          | Released | OFF        |
| CANCEL SW     | CANCEL switch            | Pressed  | ON         |
|               |                          | Released | OFF        |
| RESUME/ACC SW | RESUME/ACCELERATE switch | Pressed  | ON         |
|               |                          | Released | OFF        |
| SET SW        | SET/COAST switch         | Pressed  | ON         |
|               |                          | Released | OFF        |

**⊗ Without CONSULT**

1. Turn ignition switch ON.
2. Check the voltage between ECM harness connector terminals as per the following.

| ECM       |                                      |          | Condition                            | Voltage (V) |
|-----------|--------------------------------------|----------|--------------------------------------|-------------|
| Connector | +                                    | -        |                                      |             |
|           | Terminal                             | Terminal |                                      |             |
| M107      | 101<br>(ASCD steering switch signal) | 108      | MAIN switch: Pressed                 | Approx. 0   |
|           |                                      |          | CANCEL switch: Pressed               | Approx. 1   |
|           |                                      |          | SET/COAST switch: Pressed            | Approx. 2   |
|           |                                      |          | RESUME/ACCELERATE switch: Pressed    | Approx. 3   |
|           |                                      |          | All ASCD steering switches: Released | Approx. 4   |

Is the inspection result normal?

- YES >> GO TO 8.  
NO >> GO TO 3.

### 3. CHECK ASCD STEERING SWITCH GROUND CIRCUIT FOR OPEN AND SHORT

1. Turn ignition switch OFF.
2. Disconnect ECM harness connector.
3. Disconnect combination switch harness connector.
4. Check the continuity between combination switch and ECM harness connector.

| Combination switch | ECM      |           | Continuity |
|--------------------|----------|-----------|------------|
|                    | Terminal | Connector |            |
| 16                 | M107     | 108       | Existed    |

5. Also check harness for short to ground and short to power.

Is the inspection result normal?

- YES >> GO TO 5.  
NO >> GO TO 4.

### 4. DETECT MALFUNCTIONING PART

Check the following.

- Combination switch (spiral cable)
- Harness for open and short between ECM and combination switch

>> Repair open circuit, short to ground or short to power in harness or connectors.

### 5. CHECK ASCD STEERING SWITCH INPUT SIGNAL CIRCUIT FOR OPEN AND SHORT

1. Check the continuity between combination switch and ECM harness connector.

# P1564 ASCD STEERING SWITCH

< DTC/CIRCUIT DIAGNOSIS >

[VQ37VHR FOR USA AND CANADA]

| Combination switch |           | ECM      |  | Continuity |
|--------------------|-----------|----------|--|------------|
| Terminal           | Connector | Terminal |  |            |
| 13                 | M107      | 101      |  | Existed    |

2. Also check harness for short to ground and short to power.

Is the inspection result normal?

- YES >> GO TO 7.
- NO >> GO TO 6.

## 6. DETECT MALFUNCTIONING PART

Check the following.

- Combination switch (spiral cable)
- Harness for open and short between ECM and combination switch

>> Repair open circuit, short to ground or short to power in harness or connectors.

## 7. CHECK ASCD STEERING SWITCH

Refer to [EC-455, "Component Inspection"](#).

Is the inspection result normal?

- YES >> GO TO 8.
- NO >> Replace ASCD steering switch. Refer to [ST-31, "Exploded View"](#).

## 8. CHECK INTERMITTENT INCIDENT

Refer to [GI-44, "Intermittent Incident"](#).

>> INSPECTION END

## Component Inspection

INFOID:000000006883105

## 1. CHECK ASCD STEERING SWITCH

1. Turn ignition switch OFF.
2. Disconnect combination switch (spiral cable) harness connector M303.
3. Check resistance between combination switch harness connector terminals under the following conditions.

| Combination switch |           | Condition                            | Resistance (Ω) |
|--------------------|-----------|--------------------------------------|----------------|
| Connector          | Terminals |                                      |                |
| M303               | 13 and 16 | MAIN switch: Pressed                 | Approx. 0      |
|                    |           | CANCEL switch: Pressed               | Approx. 250    |
|                    |           | SET/COAST switch: Pressed            | Approx. 660    |
|                    |           | RESUME/ACCELERATE switch: Pressed    | Approx. 1,480  |
|                    |           | All ASCD steering switches: Released | Approx. 4,000  |

Is the inspection result normal?

- YES >> INSPECTION END
- NO >> Replace ASCD steering switch. Refer to [ST-31, "Exploded View"](#).

# P1564 ICC STEERING SWITCH

< DTC/CIRCUIT DIAGNOSIS >

[VQ37VHR FOR USA AND CANADA]

## P1564 ICC STEERING SWITCH

### DTC Logic

INFOID:000000006883106

#### DTC DETECTION LOGIC

##### NOTE:

If DTC P1564 is displayed with DTC P0605, first perform the trouble diagnosis for DTC P0605. Refer to [EC-385, "DTC Logic"](#).

| DTC No. | Trouble diagnosis name | DTC detecting condition   | Possible cause   |
|---------|------------------------|---|--|
| P1564   | ICC steering switch    | <ul style="list-style-type: none"><li>An excessively high voltage signal from the ICC steering switch is sent to ECM.</li><li>ECM detects that input signal from the ICC steering switch is out of the specified range.</li><li>ECM detects that the ICC steering switch is stuck ON.</li></ul> | <ul style="list-style-type: none"><li>Harness or connectors (The switch circuit is open or shorted.)</li><li>ICC steering switch</li><li>ECM</li></ul> |

#### DTC CONFIRMATION PROCEDURE

##### 1. PRECONDITIONING

If DTC Confirmation Procedure has been previously conducted, always perform the following procedure before conducting the next test.

- Turn ignition switch OFF and wait at least 10 seconds.
- Turn ignition switch ON.
- Turn ignition switch OFF and wait at least 10 seconds.

>> GO TO 2.

##### 2. PERFORM DTC CONFIRMATION PROCEDURE

- Turn ignition switch ON and wait at least 10 seconds.
- Press MAIN switch for at least 10 seconds, then release it and wait at least 10 seconds.
- Press DYNAMIC DRIVE ASSISTANCE SYSTEMS switch for at least 10 seconds, then release it and wait at least 10 seconds.
- Press CANCEL switch for at least 10 seconds, then release it and wait at least 10 seconds.
- Press RESUME/ACCELERATE switch for at least 10 seconds, then release it and wait at least 10 seconds.
- Press SET/COAST switch for at least 10 seconds, then release it and wait at least 10 seconds.
- Press DISTANCE switch for at least 10 seconds, then release it and wait at least 10 seconds.
- Check DTC.

##### Is DTC detected?

YES >> Go to [EC-456, "Diagnosis Procedure"](#).

NO >> INSPECTION END

#### Diagnosis Procedure

INFOID:000000006883107

##### 1. CHECK GROUND CONNECTION

- Turn ignition switch OFF.
- Check ground connection M95. Refer to Ground Inspection in [GI-47, "Circuit Inspection"](#).

##### Is the inspection result normal?

YES >> GO TO 2.

NO >> Repair or replace ground connection.

##### 2. CHECK ICC STEERING SWITCH CIRCUIT

##### With CONSULT

- Turn ignition switch ON.
- Select "MAIN SW", "DYNAMIC DRIVE ASSISTANCE SYSTEMS SW", "CANCEL SW", "RESUME/ACC SW", "SET SW" and "DIST SW" in "DATA MONITOR" mode with CONSULT.
- Check each item indication under the following conditions.



# P1564 ICC STEERING SWITCH

< DTC/CIRCUIT DIAGNOSIS >

[VQ37VHR FOR USA AND CANADA]

| Monitor item                        | Condition                               | Indication |     |
|-------------------------------------|---|------------|-----|
| MAIN SW                             | MAIN switch                             | Pressed    | ON  |
|                                     |   | Released   | OFF |
| DYNAMIC DRIVE ASSISTANCE SYSTEMS SW | DYNAMIC DRIVE ASSISTANCE SYSTEMS switch | Pressed    | ON  |
|                                     |   | Released   | OFF |
| CANCEL SW                           | CANCEL switch                           | Pressed    | ON  |
|                                     |   | Released   | OFF |
| RESUME/ACC SW                       | RESUME/ACCELERATE switch                | Pressed    | ON  |
|                                     |   | Released   | OFF |
| SET SW                              | SET/COAST switch                        | Pressed    | ON  |
|                                     |   | Released   | OFF |
| DIST SW                             | DISTANCE switch                         | Pressed    | ON  |
|                                     |   | Released   | OFF |

**⊗ Without CONSULT**

1. Turn ignition switch ON.
2. Check the voltage between ECM harness connector terminals as per the following.

| Connector | ECM                                 |          | Condition  | Voltage (V) |
|-----------|-------------------------------------|----------|--|-------------|
|           | +                                   | -        |  |             |
|           | Terminal                            | Terminal |  |             |
| M107      | 101<br>(ICC steering switch signal) | 108      | MAIN switch: Pressed                             | Approx. 0   |
|           |                                     |          | DYNAMIC DRIVE ASSISTANCE SYSTEMS switch: Pressed | Approx. 1.0 |
|           |                                     |          | CANCEL switch: Pressed                           | Approx. 1.9 |
|           |                                     |          | DISTANCE switch: Pressed                         | Approx. 2.6 |
|           |                                     |          | SET/COAST switch: Pressed                        | Approx. 3.2 |
|           |                                     |          | RESUME/ACCELERATE switch: Pressed                | Approx. 3.7 |
|           |                                     |          | All ICC steering switches: Released              | Approx. 4.2 |

Is the inspection result normal?

- YES >> GO TO 8.  
NO >> GO TO 3.

### 3. CHECK ICC STEERING SWITCH GROUND CIRCUIT FOR OPEN AND SHORT

1. Turn ignition switch OFF.
2. Disconnect ECM harness connector.
3. Disconnect combination switch harness connector.
4. Check the continuity between combination switch and ECM harness connector.

| Combination switch | ECM      |          | Continuity |
|--------------------|----------|----------|------------|
|                    | Terminal | Terminal |            |
| 16                 | M107     | 108      | Existed    |

5. Also check harness for short to ground and short to power.

Is the inspection result normal?

- YES >> GO TO 5.  
NO >> GO TO 4.

### 4. DETECT MALFUNCTIONING PART

Check the following.

- Combination switch (spiral cable)

# P1564 ICC STEERING SWITCH

[VQ37VHR FOR USA AND CANADA]

## < DTC/CIRCUIT DIAGNOSIS >

- Harness for open and short between ECM and combination switch

>> Repair open circuit, short to ground or short to power in harness or connectors.

## 5.CHECK ICC STEERING SWITCH INPUT SIGNAL CIRCUIT FOR OPEN AND SHORT

1. Check the continuity between combination switch and ECM harness connector.

| Combination switch<br>Terminal | ECM       |          | Continuity |
|--------------------------------|-----------|----------|------------|
|                                | Connector | Terminal |            |
| 13                             | M107      | 101      | Existed    |

2. Also check harness for short to ground and short to power.

Is the inspection result normal?

YES >> GO TO 7.

NO >> GO TO 6.

## 6.DETECT MALFUNCTIONING PART

Check the following.

- Combination switch (spiral cable)
- Harness for open and short between ECM and combination switch

>> Repair open circuit, short to ground or short to power in harness or connectors.

## 7.CHECK ICC STEERING SWITCH

Refer to [EC-458, "Component Inspection"](#).

Is the inspection result normal?

YES >> GO TO 8.

NO >> Replace ICC steering switch. Refer to [ST-31, "Exploded View"](#).

## 8.CHECK INTERMITTENT INCIDENT

Refer to [GI-44, "Intermittent Incident"](#).

>> INSPECTION END

## Component Inspection

INFOID:000000006883108

## 1.CHECK ICC STEERING SWITCH

1. Turn ignition switch OFF.
2. Disconnect combination switch (spiral cable) harness connector M303.
3. Check resistance between combination switch harness connector terminals under the following conditions.

| Combination switch |           | Condition  | Resistance ( $\Omega$ ) |
|--------------------|-----------|--|-------------------------|
| Connector          | Terminals |  |                         |
| M303               | 13 and 16 | MAIN switch: Pressed                             | Approx. 0               |
|                    |           | DYNAMIC DRIVE ASSISTANCE SYSTEMS switch: Pressed | Approx. 270             |
|                    |           | CANCEL switch: Pressed                           | Approx. 620             |
|                    |           | DISTANCE switch: Pressed                         | Approx. 1,090           |
|                    |           | SET/COAST switch: Pressed                        | Approx. 1,810           |
|                    |           | RESUME/ACCELERATE switch: Pressed                | Approx. 2,990           |
|                    |           | All ICC steering switches: Released              | Approx. 5,420           |

Is the inspection result normal?

YES >> INSPECTION END

# P1564 ICC STEERING SWITCH

< DTC/CIRCUIT DIAGNOSIS >

[VQ37VHR FOR USA AND CANADA]

NO >> Replace ICC steering switch. Refer to [ST-31, "Exploded View"](#).

A

EC

C

D

E

F

G

H

I

J

K

L

M

N

O

P

# P1568 ICC FUNCTION

< DTC/CIRCUIT DIAGNOSIS >

[VQ37VHR FOR USA AND CANADA]

## P1568 ICC FUNCTION

### DTC Logic

INFOID:000000006883109

### DTC DETECTION LOGIC

#### NOTE:

- If DTC P1568 is displayed with DTC UXXXX, first perform the trouble diagnosis for DTC UXXXX.
- If DTC P1568 is displayed with DTC P0605, first perform the trouble diagnosis for DTC P0605. Refer to [EC-385, "DTC Logic"](#).
- If DTC P1568 is displayed with DTC P0607, first perform the trouble diagnosis for DTC P0607. Refer to [EC-387, "DTC Logic"](#).

| DTC No. | Trouble Diagnosis Name | DTC Detecting Condition  | Possible Cause   |
|---------|------------------------|--|--|
| P1568   | ICC function           | ECM detects a difference between signals from ADAS control unit is out of specified range. | <ul style="list-style-type: none"><li>• Harness or connectors (The CAN communication line is open or shorted.)</li><li>• ADAS control unit</li><li>• ECM</li></ul> |

### DTC CONFIRMATION PROCEDURE

#### 1. PRECONDITIONING

If DTC Confirmation Procedure has been previously conducted, always perform the following procedure before conducting the next test.

1. Turn ignition switch OFF and wait at least 10 seconds.
2. Turn ignition switch ON.
3. Turn ignition switch OFF and wait at least 10 seconds.

#### TESTING CONDITION:

**Step 4 may be conducted with the drive wheels lifted in the shop or by driving the vehicle. If a road test is expected to be easier, it is unnecessary to lift the vehicle.**

>> GO TO 2.

#### 2. PERFORM DTC CONFIRMATION PROCEDURE

1. Turn ignition switch ON.
2. Press MAIN switch on ICC steering switch.
3. Drive the vehicle at more than 40 km/h (25 MPH).

#### CAUTION:

**Always drive vehicle at a safe speed.**

4. Press SET/COAST switch.
5. Check DTC.

Is DTC detected?

YES >> Go to [EC-460, "Diagnosis Procedure"](#).

NO >> INSPECTION END

### Diagnosis Procedure

INFOID:000000006883110

#### 1. REPLACE ADAS CONTROL UNIT

1. Replace ADAS control unit.
2. Perform [CCS-70, "Work Procedure \(Vehicle-To-Vehicle Distance Control Mode\)"](#).
3. Check DTC of ADAS control unit. Refer to [CCS-31, "On Board Diagnosis Function"](#).

>> INSPECTION END

# P1572 ASCD BRAKE SWITCH

< DTC/CIRCUIT DIAGNOSIS >

[VQ37VHR FOR USA AND CANADA]

## P1572 ASCD BRAKE SWITCH

### Description

INFOID:000000006883111

When the brake pedal is depressed, ASCD brake switch is turned OFF and stop lamp switch is turned ON. ECM detects the state of the brake pedal by those two types of input (ON/OFF signal). Refer to [EC-63, "AUTOMATIC SPEED CONTROL DEVICE \(ASCD\) : System Description"](#) for the ASCD function.

### DTC Logic

INFOID:000000006883112

#### DTC DETECTION LOGIC

##### NOTE:

- If DTC P1572 is displayed with DTC P0605, first perform the trouble diagnosis for DTC P0605. Refer to [EC-385, "DTC Logic"](#).
- This self-diagnosis has the one trip detection logic. When malfunction A is detected, DTC is not stored in ECM memory. And in that case, 1st trip DTC and 1st trip freeze frame data are displayed. 1st trip DTC is erased when ignition switch is turned OFF. And even when malfunction A is detected in two consecutive trips, DTC is not stored in ECM memory.

| DTC No. | Trouble diagnosis name | DTC detecting condition |  | Possible cause   |
|---------|------------------------|-------------------------|--|--|
| P1572   | ASCD brake switch      | A)                      | When the vehicle speed is above 30 km/h (19 MPH), ON signals from the stop lamp switch and the ASCD brake switch are sent to the ECM at the same time. | <ul style="list-style-type: none"><li>• Harness or connectors (The stop lamp switch circuit is shorted.)</li><li>• Harness or connectors (The ASCD brake switch circuit is shorted.)</li><li>• Stop lamp switch</li><li>• ASCD brake switch</li><li>• Incorrect stop lamp switch installation</li><li>• Incorrect ASCD brake switch installation</li><li>• ECM</li></ul> |
|         |                        | B)                      | ASCD brake switch signal is not sent to ECM for extremely long time while the vehicle is being driven.   |  |

#### DTC CONFIRMATION PROCEDURE

##### 1. PRECONDITIONING

If DTC Confirmation Procedure has been previously conducted, always perform the following procedure before conducting the next test.

1. Turn ignition switch OFF and wait at least 10 seconds.
2. Turn ignition switch ON.
3. Turn ignition switch OFF and wait at least 10 seconds.

##### NOTE:

The procedure for malfunction B is not described. It takes an extremely long time to complete the procedure for malfunction B. By performing the procedure for malfunction A, the condition that causes malfunction B can be detected.

>> GO TO 2.

##### 2. PERFORM DTC CONFIRMATION PROCEDURE FOR MALFUNCTION A

1. Start engine (VDC switch OFF).
2. Press MAIN switch and make sure that CRUISE lamp illuminates.
3. Drive the vehicle for at least 5 consecutive seconds under the following conditions.

##### CAUTION:

**Always drive vehicle at a safe speed.**

##### NOTE:

**This procedure may be conducted with the drive wheels lifted in the shop or by driving the vehicle. If a road test is expected to be easier, it is unnecessary to lift the vehicle.**

|                |                            |
|----------------|----------------------------|
| Vehicle speed  | More than 30 km/h (19 mph) |
| Selector lever | Suitable position          |

4. Check 1st trip DTC.

# P1572 ASCD BRAKE SWITCH

[VQ37VHR FOR USA AND CANADA]

< DTC/CIRCUIT DIAGNOSIS >

Is 1st trip DTC detected?

YES >> Go to [EC-462, "Diagnosis Procedure"](#).

NO >> GO TO 3.

## 3.PERFORM DTC CONFIRMATION PROCEDURE

1. Drive the vehicle for at least 5 consecutive seconds under the following conditions.

**CAUTION:**

**Always drive vehicle at a safe speed.**

**NOTE:**

**This procedure may be conducted with the drive wheels lifted in the shop or by driving the vehicle. If a road test is expected to be easier, it is unnecessary to lift the vehicle.**

|                  |   |
|------------------|---|
| Vehicle speed    | More than 30 km/h (19 mph)  |
| Selector lever   | Suitable position   |
| Driving location | Depress the brake pedal for more than 5 seconds so as not to come off from the above-mentioned vehicle speed. |

2. Check 1st trip DTC.

Is 1st trip DTC detected?

YES >> Go to [EC-462, "Diagnosis Procedure"](#).

NO >> INSPECTION END

## Diagnosis Procedure

INFOID:000000006883113

## 1.CHECK OVERALL FUNCTION-I

### With CONSULT

1. Turn ignition switch ON.
2. Select "BRAKE SW1" in "DATA MONITOR" mode with CONSULT.
3. Check "BRAKE SW1" indication under the following conditions.

| Monitor item | Condition   |                    | Indication |
|--------------|-------------|--------------------|------------|
| BRAKE SW1    | Brake pedal | Slightly depressed | OFF        |
|              | Brake pedal | Fully released     | ON         |

### Without CONSULT

1. Turn ignition switch ON.
2. Check the voltage between ECM harness connector terminals as per the following.

| Connector | ECM                               |          | Condition                         | Voltage (V)     |
|-----------|-----------------------------------|----------|-----------------------------------|-----------------|
|           | +                                 | -        |                                   |                 |
|           | Terminal                          | Terminal |                                   |                 |
| M107      | 126<br>(ASCD brake switch signal) | 128      | Brake pedal<br>Slightly depressed | Approx. 0       |
|           |                                   |          | Brake pedal<br>Fully released     | Battery voltage |

Is the inspection result normal?

YES >> GO TO 2.

NO >> GO TO 3.

## 2.CHECK OVERALL FUNCTION-II

### With CONSULT

Select "BRAKE SW2" and check indication under the following conditions.

# P1572 ASCD BRAKE SWITCH

< DTC/CIRCUIT DIAGNOSIS >

[VQ37VHR FOR USA AND CANADA]

| Monitor item | Condition   |                    | Indication |
|--------------|-------------|--------------------|------------|
| BRAKE SW2    | Brake pedal | Slightly depressed | ON         |
|              |             | Fully released     | OFF        |

## Without CONSULT

Check the voltage between ECM harness connector terminals as per the following.

| Connector | ECM                              |          | Condition      | Voltage (V)        |                 |
|-----------|----------------------------------|----------|----------------|--------------------|-----------------|
|           | +                                | -        |                |                    |                 |
|           | Terminal                         | Terminal |                |                    |                 |
| M107      | 122<br>(Stop lamp switch signal) | 128      | Brake pedal    | Slightly depressed | Battery voltage |
|           |                                  |          | Fully released | Approx. 0          |                 |

Is the inspection result normal?

YES >> GO TO 13.

NO >> GO TO 8.

## 3. CHECK ASCD BRAKE SWITCH POWER SUPPLY CIRCUIT

1. Turn ignition switch OFF.
2. Disconnect ASCD brake switch harness connector.
3. Turn ignition switch ON.
4. Check the voltage between ASCD brake switch harness connector and ground.

| ASCD brake switch |          | Ground | Voltage         |
|-------------------|----------|--------|-----------------|
| Connector         | Terminal |        |                 |
| E109              | 1        | Ground | Battery voltage |

Is the inspection result normal?

YES >> GO TO 5.

NO >> GO TO 4.

## 4. DETECT MALFUNCTIONING PART

Check the following.

- Fuse block (J/B) connector E103
- 10 A fuse (No. 3)
- Harness for open or short between ASCD brake switch and fuse

>> Repair open circuit or short to ground in harness or connectors.

## 5. CHECK ASCD BRAKE SWITCH INPUT SIGNAL CIRCUIT FOR OPEN AND SHORT

1. Turn ignition switch OFF.
2. Disconnect ECM harness connector.
3. Check the continuity between ASCD brake switch harness connector and ECM harness connector.

| ASCD brake switch |          | ECM       |          | Continuity |
|-------------------|----------|-----------|----------|------------|
| Connector         | Terminal | Connector | Terminal |            |
| E109              | 2        | M107      | 126      | Existed    |

4. Also check harness for short to ground and short to power.

Is the inspection result normal?

YES >> GO TO 7.

NO >> GO TO 6.

## 6. DETECT MALFUNCTIONING PART

Check the following.

- Harness connectors E106, M6

# P1572 ASCD BRAKE SWITCH

< DTC/CIRCUIT DIAGNOSIS >

[VQ37VHR FOR USA AND CANADA]

- Harness for open or short between ECM and ASCD brake switch

>> Repair open circuit, short to ground or short to power in harness or connectors.

## 7. CHECK ASCD BRAKE SWITCH

Refer to [EC-465, "Component Inspection \(ASCD Brake Switch\)"](#)

Is the inspection result normal?

YES >> GO TO 13.

NO >> Replace ASCD brake switch. Refer to [BR-18, "Exploded View"](#).

## 8. CHECK STOP LAMP SWITCH POWER SUPPLY CIRCUIT

1. Turn ignition switch OFF.
2. Disconnect stop lamp switch harness connector.
3. Check the voltage between stop lamp switch harness connector and ground.

| Stop lamp switch |          | Ground | Voltage         |
|------------------|----------|--------|-----------------|
| Connector        | Terminal |        |                 |
| E110             | 1        | Ground | Battery voltage |

Is the inspection result normal?

YES >> GO TO 10.

NO >> GO TO 9.

## 9. DETECT MALFUNCTIONING PART

Check the following.

- Fuse block (J/B) connector E103
- 10A fuse (No. 7)
- Harness for open or short between stop lamp switch and battery

>> Repair open circuit, short to ground or short to power in harness or connectors.

## 10. CHECK STOP LAMP SWITCH INPUT SIGNAL CIRCUIT FOR OPEN AND SHORT

1. Disconnect ECM harness connector.
2. Check the continuity between stop lamp switch harness connector and ECM harness connector.

| Stop lamp switch |          | ECM       |          | Continuity |
|------------------|----------|-----------|----------|------------|
| Connector        | Terminal | Connector | Terminal |            |
| E110             | 2        | M107      | 122      | Existed    |

3. Also check harness for short to ground and short to power.

Is the inspection result normal?

YES >> GO TO 12.

NO >> GO TO 11.

## 11. DETECT MALFUNCTIONING PART

Check the following.

- Fuse block (J/B) connectors E103, M2
- Harness for open or short between ECM and stop lamp switch

>> Repair open circuit, short to ground or short to power in harness or connectors.

## 12. CHECK STOP LAMP SWITCH

Refer to [EC-465, "Component Inspection \(Stop Lamp Switch\)"](#)

Is the inspection result normal?

YES >> GO TO 13.

NO >> Replace stop lamp switch. Refer to [BR-18, "Exploded View"](#).



# P1572 ASCD BRAKE SWITCH

< DTC/CIRCUIT DIAGNOSIS >

[VQ37VHR FOR USA AND CANADA]

## 13.CHECK INTERMITTENT INCIDENT

Refer to [GI-44. "Intermittent Incident"](#).

>> INSPECTION END

### Component Inspection (ASCD Brake Switch)

INFOID:000000006883114

#### 1.CHECK ASCD BRAKE SWITCH-I

1. Turn ignition switch OFF.
2. Disconnect ASCD brake switch harness connector.
3. Check the continuity between ASCD brake switch terminals under the following conditions.

| Terminals | Condition   |                    | Continuity  |
|-----------|-------------|--------------------|-------------|
| 1 and 2   | Brake pedal | Fully released     | Existed     |
|           |             | Slightly depressed | Not existed |

Is the inspection result normal?

- YES >> INSPECTION END  
NO >> GO TO 2.

#### 2.CHECK ASCD BRAKE SWITCH-II

1. Adjust ASCD brake switch installation. Refer to [BR-19. "Inspection and Adjustment"](#).
2. Check the continuity between ASCD brake switch terminals under the following conditions.

| Terminals | Condition   |                    | Continuity  |
|-----------|-------------|--------------------|-------------|
| 1 and 2   | Brake pedal | Fully released     | Existed     |
|           |             | Slightly depressed | Not existed |

Is the inspection result normal?

- YES >> INSPECTION END  
NO >> Replace ASCD brake switch. Refer to [BR-18. "Exploded View"](#).

### Component Inspection (Stop Lamp Switch)

INFOID:000000006883115

#### 1.CHECK STOP LAMP SWITCH-I

1. Turn ignition switch OFF.
2. Disconnect stop lamp switch harness connector.
3. Check the continuity between stop lamp switch terminals under the following conditions.

| Terminals | Condition   |                    | Continuity  |
|-----------|-------------|--------------------|-------------|
| 1 and 2   | Brake pedal | Fully released     | Not existed |
|           |             | Slightly depressed | Existed     |

Is the inspection result normal?

- YES >> INSPECTION END  
NO >> GO TO 2.

#### 2.CHECK STOP LAMP SWITCH-II

1. Adjust stop lamp switch installation. Refer to [BR-19. "Inspection and Adjustment"](#).
2. Check the continuity between stop lamp switch terminals under the following conditions.

| Terminals | Condition   |                    | Continuity  |
|-----------|-------------|--------------------|-------------|
| 1 and 2   | Brake pedal | Fully released     | Not existed |
|           |             | Slightly depressed | Existed     |

Is the inspection result normal?

## P1572 ASCD BRAKE SWITCH

< DTC/CIRCUIT DIAGNOSIS >

[VQ37VHR FOR USA AND CANADA]

---

YES >> INSPECTION END

NO >> Replace stop lamp switch. Refer to [BR-18, "Exploded View"](#).

# P1572 ICC BRAKE SWITCH

< DTC/CIRCUIT DIAGNOSIS >

[VQ37VHR FOR USA AND CANADA]

## P1572 ICC BRAKE SWITCH

### DTC Logic

INFOID:000000006883116

### DTC DETECTION LOGIC

#### NOTE:

- If DTC P1572 is displayed with DTC P0605, first perform the trouble diagnosis for DTC P0605. Refer to [EC-385, "DTC Logic"](#).
- This self-diagnosis has the one trip detection logic. When malfunction A is detected, DTC is not stored in ECM memory. And in that case, 1st trip DTC and 1st trip freeze frame data are displayed. 1st trip DTC is erased when ignition switch is turned OFF. And even when malfunction A is detected in two consecutive trips, DTC is not stored in ECM memory.

| DTC No. | Trouble diagnosis name | DTC detecting condition |  | Possible cause   |
|---------|------------------------|-------------------------|--|--|
| P1572   | ICC brake switch       | A)                      | ON signals from the stop lamp switch and the ICC brake switch are sent to ECM at the same time.      | <ul style="list-style-type: none"><li>• Harness or connectors (The stop lamp switch circuit is shorted.)</li><li>• Harness or connectors (The ICC brake switch circuit is shorted.)</li><li>• Stop lamp switch</li><li>• ICC brake switch</li><li>• ICC brake hold relay</li><li>• Incorrect stop lamp switch installation</li><li>• Incorrect ICC brake switch installation</li><li>• ECM</li></ul> |
|         |                        | B)                      | ICC brake switch signal is not sent to ECM for extremely long time while the vehicle is being driven |  |

### DTC CONFIRMATION PROCEDURE

#### 1. PRECONDITIONING

If DTC Confirmation Procedure has been previously conducted, always perform the following procedure before conducting the next test.

1. Turn ignition switch OFF and wait at least 10 seconds.
2. Turn ignition switch ON.
3. Turn ignition switch OFF and wait at least 10 seconds.

#### NOTE:

The procedure for malfunction B is not described. It takes an extremely long time to complete the procedure for malfunction B. By performing the procedure for malfunction A, the condition that causes malfunction B can be detected.

>> GO TO 2.

#### 2. PERFORM DTC CONFIRMATION PROCEDURE

1. Start engine (VDC switch OFF).
2. Press MAIN switch and make sure that CRUISE lamp illuminates.
3. Drive the vehicle for at least 5 consecutive seconds under the following conditions.

#### CAUTION:

**Always drive vehicle at a safe speed.**

#### NOTE:

**This procedure may be conducted with the drive wheels lifted in the shop or by driving the vehicle. If a road test is expected to be easier, it is unnecessary to lift the vehicle.**

|                |                            |
|----------------|----------------------------|
| Vehicle speed  | More than 30 km/h (19 mph) |
| Selector lever | Suitable position          |

4. Check 1st trip DTC.

Is 1st trip DTC detected?

- YES >> Go to [EC-468, "Diagnosis Procedure"](#).  
NO >> GO TO 3.

#### 3. PERFORM DTC CONFIRMATION PROCEDURE

1. Drive the vehicle for at least 5 consecutive seconds under the following conditions.

# P1572 ICC BRAKE SWITCH

< DTC/CIRCUIT DIAGNOSIS >

[VQ37VHR FOR USA AND CANADA]

## CAUTION:

Always drive vehicle at a safe speed.

## NOTE:

This procedure may be conducted with the drive wheels lifted in the shop or by driving the vehicle. If a road test is expected to be easier, it is unnecessary to lift the vehicle.

|                  |   |
|------------------|---|
| Vehicle speed    | More than 30 km/h (19 mph)  |
| Selector lever   | Suitable position   |
| Driving location | Depress the brake pedal for more than 5 seconds so as not to come off from the above-mentioned vehicle speed. |

2. Check 1st trip DTC.

Is 1st trip DTC detected?

YES >> Go to [EC-468, "Diagnosis Procedure"](#).

NO >> INSPECTION END

## Diagnosis Procedure

INFOID:000000006883117

### 1. CHECK OVERALL FUNCTION-I

#### With CONSULT

1. Turn ignition switch ON.
2. Select "BRAKE SW1" in "DATA MONITOR" mode with CONSULT.
3. Check "BRAKE SW1" indication under the following conditions.

| Monitor item | Condition   |                    | Indication |
|--------------|-------------|--------------------|------------|
| BRAKE SW1    | Brake pedal | Slightly depressed | OFF        |
|              | Brake pedal | Fully released     | ON         |

#### Without CONSULT

1. Turn ignition switch ON.
2. Check the voltage between ECM harness connector terminals under the following conditions.

| Connector | ECM                              |     | Condition   | Voltage (V)        |                 |
|-----------|----------------------------------|-----|-------------|--------------------|-----------------|
|           | +                                | -   |             |                    |                 |
| Terminal  | Terminal                         |     |             |                    |                 |
| M107      | 126<br>(ICC brake switch signal) | 128 | Brake pedal | Slightly depressed | Approx. 0       |
|           |                                  |     | Brake pedal | Fully released     | Battery voltage |

Is the inspection result normal?

YES >> GO TO 2.

NO >> GO TO 3.

### 2. CHECK OVERALL FUNCTION-II

#### With CONSULT

Select "BRAKE SW2" and check indication under the following conditions.

| Monitor item | Condition   |                    | Indication |
|--------------|-------------|--------------------|------------|
| BRAKE SW2    | Brake pedal | Slightly depressed | ON         |
|              |             | Fully released     | OFF        |

#### Without CONSULT

Check the voltage between ECM harness connector terminals as per the following.

# P1572 ICC BRAKE SWITCH

< DTC/CIRCUIT DIAGNOSIS >

[VQ37VHR FOR USA AND CANADA]

| ECM       |                                  |          | Condition      | Voltage (V)        |                 |
|-----------|----------------------------------|----------|----------------|--------------------|-----------------|
| Connector | +                                | -        |                |                    |                 |
|           | Terminal                         | Terminal |                |                    |                 |
| M107      | 122<br>(Stop lamp switch signal) | 128      | Brake pedal    | Slightly depressed | Battery voltage |
|           |                                  |          | Fully released | Approx. 0          |                 |

Is the inspection result normal?

YES >> GO TO 14.

NO >> GO TO 8.

## 3.CHECK ICC BRAKE SWITCH POWER SUPPLY CIRCUIT

1. Turn ignition switch OFF.
2. Disconnect ICC brake switch harness connector.
3. Turn ignition switch ON.
4. Check the voltage between ICC brake switch harness connector and ground.

| ICC brake switch |          | Ground | Voltage         |
|------------------|----------|--------|-----------------|
| Connector        | Terminal |        |                 |
| E114             | 1        | Ground | Battery voltage |

Is the inspection result normal?

YES >> GO TO 5.

NO >> GO TO 4.

## 4.DETECT MALFUNCTIONING PART

Check the following.

- Fuse block (J/B) connector E103
- 10 A fuse (No. 3)
- Harness for open or short between ICC brake switch and fuse

>> Repair open circuit or short to ground in harness or connectors.

## 5.CHECK ICC BRAKE SWITCH INPUT SIGNAL CIRCUIT FOR OPEN AND SHORT

1. Turn ignition switch OFF.
2. Disconnect ECM harness connector.
3. Check the continuity between ICC brake switch harness connector and ECM harness connector.

| ICC brake switch |          | ECM       |          | Continuity |
|------------------|----------|-----------|----------|------------|
| Connector        | Terminal | Connector | Terminal |            |
| E114             | 2        | M107      | 126      | Existed    |

4. Also check harness for short to ground and short to power.

Is the inspection result normal?

YES >> GO TO 7.

NO >> GO TO 6.

## 6.DETECT MALFUNCTIONING PART

Check the following.

- Harness connectors E106, M6
- Harness for open or short between ICC brake switch and ECM

>> Repair open circuit, short to ground or short to power in harness or connectors.

## 7.CHECK ICC BRAKE SWITCH

Refer to [EC-471, "Component Inspection \(ICC Brake Switch\)"](#).

# P1572 ICC BRAKE SWITCH

[VQ37VHR FOR USA AND CANADA]

< DTC/CIRCUIT DIAGNOSIS >

Is the inspection result normal?

YES >> GO TO 14.

NO >> Replace ICC brake switch. Refer to [BR-18. "Exploded View"](#).

## 8. CHECK STOP LAMP SWITCH POWER SUPPLY CIRCUIT

1. Turn ignition switch OFF.
2. Disconnect stop lamp switch harness connector.
3. Disconnect ICC brake hold relay harness connector.
4. Check the voltage between stop lamp switch harness connector and ground.

| Stop lamp switch |          | Ground | Voltage         |
|------------------|----------|--------|-----------------|
| Connector        | Terminal |        |                 |
| E110             | 1        | Ground | Battery voltage |

5. Check the voltage between ICC brake hold relay harness connector and ground.

| ICC brake hold relay |          | Ground | Voltage         |
|----------------------|----------|--------|-----------------|
| Connector            | Terminal |        |                 |
| E92                  | 5        | Ground | Battery voltage |

Is the inspection result normal?

YES >> GO TO 10.

NO >> GO TO 9.

## 9. DETECT MALFUNCTIONING PART

Check the following.

- Fuse block (J/B) connector E103
- 10 A fuse (No. 7)
- Harness for open or short between battery and stop lamp switch
- Harness for open or short between battery and ICC brake hold relay

>> Repair open circuit or short to ground in harness or connectors.

## 10. CHECK STOP LAMP SWITCH INPUT SIGNAL CIRCUIT FOR OPEN AND SHORT

1. Disconnect ECM harness connector.
2. Check the continuity between stop lamp switch harness connector and ECM harness connector.

| Stop lamp switch |          | ECM       |          | Continuity |
|------------------|----------|-----------|----------|------------|
| Connector        | Terminal | Connector | Terminal |            |
| E110             | 2        | M107      | 122      | Existed    |

3. Check the continuity between ICC brake hold relay harness connector and ECM harness connector.

| ICC brake hold relay |          | ECM       |          | Continuity |
|----------------------|----------|-----------|----------|------------|
| Connector            | Terminal | Connector | Terminal |            |
| E92                  | 3        | M107      | 122      | Existed    |

4. Also check harness for short to ground and short to power.

Is the inspection result normal?

YES >> GO TO 12.

NO >> GO TO 11.

## 11. DETECT MALFUNCTIONING PART

Check the following.

- Fuse block (J/B) connector E103, M2
- Harness for open or short between ECM and stop lamp switch
- Harness for open or short between ECM and ICC brake hold relay

# P1572 ICC BRAKE SWITCH

< DTC/CIRCUIT DIAGNOSIS >

[VQ37VHR FOR USA AND CANADA]

>> Repair open circuit, short to ground or short to power in harness or connectors.

## 12. CHECK STOP LAMP SWITCH

Refer to [EC-471, "Component Inspection \(Stop Lamp Switch\)"](#).

Is the inspection result normal?

YES >> GO TO 13.

NO >> Replace stop lamp switch. Refer to [BR-18, "Exploded View"](#).

## 13. CHECK ICC BRAKE HOLD RELAY

Refer to [EC-472, "Component Inspection \(ICC Brake Hold Relay\)"](#).

Is the inspection result normal?

YES >> GO TO 14.

NO >> Replace ICC brake hold relay.

## 14. CHECK INTERMITTENT INCIDENT

Refer to [GI-44, "Intermittent Incident"](#).

>> INSPECTION END

## Component Inspection (ICC Brake Switch)

INFOID:000000006883118

### 1. CHECK ICC BRAKE SWITCH-I

1. Turn ignition switch OFF.
2. Disconnect ICC brake switch harness connector.
3. Check the continuity between ICC brake switch terminals under the following conditions.

| Terminals | Condition   |                    | Continuity  |
|-----------|-------------|--------------------|-------------|
| 1 and 2   | Brake pedal | Fully released     | Existed     |
|           |             | Slightly depressed | Not existed |

Is the inspection result normal?

YES >> INSPECTION END

NO >> GO TO 2.

### 2. CHECK ICC BRAKE SWITCH-II

1. Adjust ICC brake switch installation. Refer to [BR-19, "Inspection and Adjustment"](#).
2. Check the continuity between ICC brake switch terminals under the following conditions.

| Terminals | Condition   |                    | Continuity  |
|-----------|-------------|--------------------|-------------|
| 1 and 2   | Brake pedal | Fully released     | Existed     |
|           |             | Slightly depressed | Not existed |

Is the inspection result normal?

YES >> INSPECTION END

NO >> Replace ICC brake switch. Refer to [BR-18, "Exploded View"](#).

## Component Inspection (Stop Lamp Switch)

INFOID:000000006883119

### 1. CHECK STOP LAMP SWITCH-I

1. Turn ignition switch OFF.
2. Disconnect stop lamp switch harness connector.
3. Check the continuity between stop lamp switch terminals under the following conditions.

# P1572 ICC BRAKE SWITCH

< DTC/CIRCUIT DIAGNOSIS >

[VQ37VHR FOR USA AND CANADA]

| Terminals | Condition   |                    | Continuity  |
|-----------|-------------|--------------------|-------------|
| 1 and 2   | Brake pedal | Fully released     | Not existed |
|           |             | Slightly depressed | Existed     |

Is the inspection result normal?

YES >> INSPECTION END

NO >> GO TO 2.

## 2.CHECK STOP LAMP SWITCH-II

1. Adjust stop lamp switch installation. Refer to [BR-19, "Inspection and Adjustment"](#).
2. Check the continuity between stop lamp switch terminals under the following conditions.

| Terminals | Condition   |                    | Continuity  |
|-----------|-------------|--------------------|-------------|
| 1 and 2   | Brake pedal | Fully released     | Not existed |
|           |             | Slightly depressed | Existed     |

Is the inspection result normal?

YES >> INSPECTION END

NO >> Replace stop lamp switch. Refer to [BR-18, "Exploded View"](#).

## Component Inspection (ICC Brake Hold Relay)

INFOID:000000006883120

### 1.CHECK ICC BRAKE HOLD RELAY

1. Turn ignition switch OFF.
2. Remove ICC brake hold relay.
3. Check the continuity between ICC brake hold relay terminals under the following conditions.

| Terminals | Condition   | Continuity  |
|-----------|---|-------------|
| 3 and 5   | 12V direct current supply between terminals 1 and 2 | Existed     |
|           | No current supply                                   | Not existed |

Is the inspection result normal?

YES >> INSPECTION END

NO >> Replace ICC brake hold relay

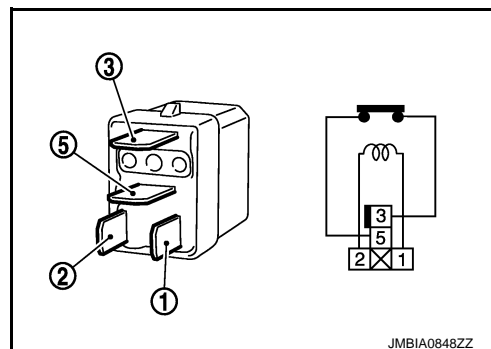



# P1574 ASCD VEHICLE SPEED SENSOR

< DTC/CIRCUIT DIAGNOSIS >

[VQ37VHR FOR USA AND CANADA]

## P1574 ASCD VEHICLE SPEED SENSOR

### Description

INFOID:000000006883121

The ECM receives two vehicle speed signals via the CAN communication line. One is sent from “combination meter”, and the other is from TCM (Transmission control module). The ECM uses these signals for ASCD control. Refer to [EC-63, "AUTOMATIC SPEED CONTROL DEVICE \(ASCD\) : System Description"](#) for ASCD functions.

### DTC Logic

INFOID:000000006883122

#### DTC DETECTION LOGIC

##### NOTE:

- If DTC P1574 is displayed with DTC UXXXX, first perform the trouble diagnosis for DTC UXXXX.
- If DTC P1574 is displayed with DTC P0500, first perform the trouble diagnosis for DTC P0500. Refer to [EC-370, "DTC Logic"](#).
- If DTC P1574 is displayed with DTC P0605, first perform the trouble diagnosis for DTC P0605. Refer to [EC-385, "DTC Logic"](#).
- If DTC P1574 is displayed with DTC P0607, first perform the trouble diagnosis for DTC P0607. Refer to [EC-387, "DTC Logic"](#).

| DTC No. | Trouble diagnosis name    | DTC detecting condition   | Possible cause  |
|---------|---------------------------|---|---|
| P1574   | ASCD vehicle speed sensor | The difference between the two vehicle speed signals is out of the specified range. | <ul style="list-style-type: none"><li>• Harness or connectors<br/>(The CAN communication line is open or shorted.)</li><li>• Combination meter</li><li>• ABS actuator and electric unit (control unit)</li><li>• Wheel sensor</li><li>• TCM</li><li>• ECM</li></ul> |

#### DTC CONFIRMATION PROCEDURE

##### 1. PRECONDITIONING

If DTC Confirmation Procedure has been previously conducted, always perform the following procedure before conducting the next test.

1. Turn ignition switch OFF and wait at least 10 seconds.
2. Turn ignition switch ON.
3. Turn ignition switch OFF and wait at least 10 seconds.

>> GO TO 2.

##### 2. PERFORM DTC CONFIRMATION PROCEDURE

1. Start engine (VDC switch OFF).
2. Drive the vehicle at more than 40 km/h (25 MPH).

##### CAUTION:

**Always drive vehicle at a safe speed.**

##### NOTE:

**This procedure may be conducted with the drive wheels lifted in the shop or by driving the vehicle. If a road test is expected to be easier, it is unnecessary to lift the vehicle.**

3. Check DTC.

Is DTC detected?

- YES >> Go to [EC-473, "Diagnosis Procedure"](#).  
NO >> INSPECTION END

### Diagnosis Procedure

INFOID:000000006883123

##### 1. CHECK DTC WITH TCM

Check DTC with TCM. Refer to [TM-59, "Diagnosis Description"](#).

Is the inspection result normal?

## P1574 ASCD VEHICLE SPEED SENSOR

[VQ37VHR FOR USA AND CANADA]

< DTC/CIRCUIT DIAGNOSIS >

---

YES >> GO TO 2.

NO >> Perform trouble shooting relevant to DTC indicated.

### 2.CHECK DTC WITH “ABS ACTUATOR AND ELECTRIC UNIT (CONTROL UNIT)”

---

Refer to [BRC-40. "CONSULT Function"](#).

Is the inspection result normal?

YES >> GO TO 3.

NO >> Repair or replace.

### 3.CHECK DTC WITH “COMBINATION METER”

---

Refer to [MWI-31. "CONSULT Function"](#).

>> INSPECTION END

# P1574 ICC VEHICLE SPEED SENSOR

< DTC/CIRCUIT DIAGNOSIS >

[VQ37VHR FOR USA AND CANADA]

## P1574 ICC VEHICLE SPEED SENSOR

### Description

INFOID:000000006883124

The ECM receives two vehicle speed signals via CAN communication line. One is sent from “combination meter”, and the other is from TCM (Transmission control module). The ECM uses these signals for ICC control. Refer to [CCS-13, "System Description"](#) for ICC functions.

### DTC Logic

INFOID:000000006883125

#### DTC DETECTION LOGIC

##### NOTE:

- If DTC P1574 is displayed with DTC UXXXX, first perform the trouble diagnosis for DTC UXXXX.
- If DTC P1574 is displayed with DTC P0500, first perform the trouble diagnosis for DTC P0500. Refer to [EC-370, "DTC Logic"](#).
- If DTC P1574 is displayed with DTC P0605, first perform the trouble diagnosis for DTC P0605. Refer to [EC-385, "DTC Logic"](#).
- If DTC P1574 is displayed with DTC P0607, first perform the trouble diagnosis for DTC P0607. Refer to [EC-387, "DTC Logic"](#).

| DTC No. | Trouble diagnosis name   | DTC detecting condition   | Possible cause  |
|---------|--------------------------|---|---|
| P1574   | ICC vehicle speed sensor | The difference between the two vehicle speed signals is out of the specified range. | <ul style="list-style-type: none"><li>• Harness or connectors<br/>(The CAN communication line is open or shorted.)</li><li>• Combination meter</li><li>• ABS actuator and electric unit (control unit)</li><li>• Wheel sensor</li><li>• TCM</li><li>• ECM</li></ul> |

#### DTC CONFIRMATION PROCEDURE

##### 1. PRECONDITIONING

If DTC Confirmation Procedure has been previously conducted, always perform the following procedure before conducting the next test.

1. Turn ignition switch OFF and wait at least 10 seconds.
2. Turn ignition switch ON.
3. Turn ignition switch OFF and wait at least 10 seconds.

>> GO TO 2.

##### 2. PERFORM DTC CONFIRMATION PROCEDURE

1. Start engine (VDC switch OFF).
2. Drive the vehicle at more than 40 km/h (25 MPH).

##### CAUTION:

**Always drive vehicle at a safe speed.**

##### NOTE:

**This procedure may be conducted with the drive wheels lifted in the shop or by driving the vehicle. If a road test is expected to be easier, it is unnecessary to lift the vehicle.**

3. Check DTC.

Is DTC detected?

- YES >> Go to [EC-475, "Diagnosis Procedure"](#).  
NO >> INSPECTION END

### Diagnosis Procedure

INFOID:000000006883126

##### 1. CHECK DTC WITH TCM

Check DTC with TCM. Refer to [TM-59, "Diagnosis Description"](#).

Is the inspection result normal?

- YES >> GO TO 2.

## P1574 ICC VEHICLE SPEED SENSOR

[VQ37VHR FOR USA AND CANADA]

< DTC/CIRCUIT DIAGNOSIS >

---

NO >> Perform trouble shooting relevant to DTC indicated.

### 2.CHECK DTC WITH “ABS ACTUATOR AND ELECTRIC UNIT (CONTROL UNIT)”

---

Refer to [BRC-40, "CONSULT Function"](#).

Is the inspection result normal?

YES >> GO TO 3.

NO >> Repair or replace.

### 3.CHECK DTC WITH “COMBINATION METER”

---

Check combination meter function.

Refer to [MWI-31, "CONSULT Function"](#).

>> INSPECTION END

# P1606 VVEL CONTROL MODULE

< DTC/CIRCUIT DIAGNOSIS >

[VQ37VHR FOR USA AND CANADA]

## P1606 VVEL CONTROL MODULE

### DTC Logic

INFOID:000000006883127

### DTC DETECTION LOGIC

| DTC No. | Trouble diagnosis name | DTC detecting condition   | Possible cause  |
|---------|------------------------|---|---|
| P1606   | VVEL control module    | <ul style="list-style-type: none"><li>VVEL control module calculation function is malfunctioning.</li><li>VVEL EEPROM system is malfunctioning.</li></ul> | <ul style="list-style-type: none"><li>VVEL control module</li></ul> |

### DTC CONFIRMATION PROCEDURE

#### 1. PRECONDITIONING

If DTC Confirmation Procedure has been previously conducted, always perform the following procedure before conducting the next test.

- Turn ignition switch OFF and wait at least 10 seconds.
- Turn ignition switch ON.
- Turn ignition switch OFF and wait at least 10 seconds.

#### TESTING CONDITION:

Before performing the following procedure, confirm that battery voltage is more than 10 V at idle.

>> GO TO 2.

#### 2. PERFORM DTC CONFIRMATION PROCEDURE

- Turn ignition switch ON and wait at least 1 second.
- Check DTC.

Is DTC detected?

- YES >> Go to [EC-477, "Diagnosis Procedure"](#).  
NO >> INSPECTION END

### Diagnosis Procedure

INFOID:000000006883128

#### 1. PERFORM DTC CONFIRMATION PROCEDURE

- Turn ignition switch ON.
- Erase DTC.
- Perform DTC Confirmation Procedure.  
See [EC-477, "DTC Logic"](#).

Is the DTC P1606 displayed again?

- YES >> GO TO 2.  
NO >> INSPECTION END

#### 2. REPLACE VVEL CONTROL MODULE

- Replace VVEL control module.
- Go to [EC-145, "Work Procedure"](#).

>> INSPECTION END

# P1607 VVEL CONTROL MODULE

< DTC/CIRCUIT DIAGNOSIS >

[VQ37VHR FOR USA AND CANADA]

## P1607 VVEL CONTROL MODULE

### DTC Logic

INFOID:000000006883129

### DTC DETECTION LOGIC

| DTC No. | Trouble diagnosis name      | DTC detecting condition  | Possible cause        |
|---------|-----------------------------|--|-----------------------|
| P1607   | VVEL control module circuit | • The internal circuit of the VVEL control module is malfunctioning. | • VVEL control module |

### DTC CONFIRMATION PROCEDURE

#### 1. PRECONDITIONING

If DTC Confirmation Procedure has been previously conducted, always perform the following procedure before conducting the next test.

1. Turn ignition switch OFF and wait at least 10 seconds.
2. Turn ignition switch ON.
3. Turn ignition switch OFF and wait at least 10 seconds.

#### TESTING CONDITION:

**Before performing the following procedure, confirm that battery voltage is more than 10 V at idle.**

>> GO TO 2.

#### 2. PERFORM DTC CONFIRMATION PROCEDURE

1. Start engine and let it idle for at least 1 second.
2. Check DTC.

#### Is DTC detected?

- YES >> Go to [EC-478. "Diagnosis Procedure"](#).  
NO >> INSPECTION END

### Diagnosis Procedure

INFOID:000000006883130

#### 1. PERFORM DTC CONFIRMATION PROCEDURE

1. Turn ignition switch ON.
2. Erase DTC.
3. Perform DTC Confirmation Procedure.  
See [EC-478. "DTC Logic"](#).

#### Is the DTC P1607 displayed again?

- YES >> GO TO 2.  
NO >> INSPECTION END

#### 2. REPLACE VVEL CONTROL MODULE

1. Replace VVEL control module.
2. Go to [EC-145. "Work Procedure"](#).

>> INSPECTION END

# P1608 VVEL SENSOR POWER SUPPLY

< DTC/CIRCUIT DIAGNOSIS >

[VQ37VHR FOR USA AND CANADA]

## P1608 VVEL SENSOR POWER SUPPLY

### DTC Logic

INFOID:000000006883131

### DTC DETECTION LOGIC

| DTC No. | Trouble diagnosis name           | DTC detecting condition  | Possible cause   |
|---------|----------------------------------|--|--|
| P1608   | VVEL sensor power supply circuit | VVEL control module detects a voltage of power source for sensor is excessively low or high. | <ul style="list-style-type: none"><li>• Harness or connectors (VVEL control shaft position sensor power supply circuit is open or shorted.)</li><li>• VVEL control shaft position sensor</li><li>• VVEL control module</li></ul> |

### DTC CONFIRMATION PROCEDURE

#### 1. PRECONDITIONING

If DTC Confirmation Procedure has been previously conducted, always perform the following procedure before conducting the next test.

1. Turn ignition switch OFF and wait at least 10 seconds.
2. Turn ignition switch ON.
3. Turn ignition switch OFF and wait at least 10 seconds.

#### TESTING CONDITION:

Before performing the following procedure, confirm that battery voltage is more than 10 V at idle.

>> GO TO 2.

#### 2. PERFORM DTC CONFIRMATION PROCEDURE

1. Turn ignition switch ON and wait at least 1 second.
2. Check DTC.

#### Is DTC detected?

- YES >> Go to [EC-479. "Diagnosis Procedure"](#).  
NO >> INSPECTION END

### Diagnosis Procedure

INFOID:000000006883132

#### 1. CHECK GROUND CONNECTION

1. Turn ignition switch OFF.
2. Check ground connection M95. Refer to Ground Inspection in [GI-47. "Circuit Inspection"](#).

#### Is the inspection result normal?

- YES >> GO TO 2.  
NO >> Repair or replace ground connection.

#### 2. CHECK VVEL CONTROL SHAFT POSITION SENSOR POWER SUPPLY CIRCUIT

1. Disconnect VVEL control shaft position sensor harness connector.
2. Turn ignition switch ON.
3. Check the voltage between VVEL control shaft position sensor harness connector and ground.

| VVEL control shaft position sensor |           |          | Ground | Voltage (V) |
|------------------------------------|-----------|----------|--------|-------------|
| Bank                               | Connector | Terminal |        |             |
| 1                                  | F46       | 3        | Ground | Approx. 5   |
|                                    |           | 6        |        |             |
| 2                                  | F47       | 3        |        |             |
|                                    |           | 6        |        |             |

#### Is the inspection result normal?

- YES >> GO TO 7.  
NO >> GO TO 3.

# P1608 VVEL SENSOR POWER SUPPLY

[VQ37VHR FOR USA AND CANADA]

< DTC/CIRCUIT DIAGNOSIS >

## 3. CHECK VVEL CONTROL SHAFT POSITION SENSOR POWER SUPPLY CIRCUIT FOR OPEN AND SHORT

1. Turn ignition switch OFF.
2. Disconnect VVEL control module harness connector.
3. Check the continuity between VVEL control shaft position sensor harness connector and VVEL control module harness connector.

| VVEL control shaft position sensor |           |          | VVEL control module |          | Continuity |
|------------------------------------|-----------|----------|---------------------|----------|------------|
| Bank                               | Connector | Terminal | Connector           | Terminal |            |
| 1                                  | F46       | 3        | E15                 | 9        | Existed    |
|                                    |           | 6        |                     | 22       |            |
| 2                                  | F47       | 3        |                     | 7        |            |
|                                    |           | 6        |                     | 20       |            |

4. Also check harness for short to ground and power.

Is the inspection result normal?

YES >> GO TO 5.

NO >> GO TO 4.

## 4. DETECT MALFUNCTIONING PART

Check the following.

- Harness connectors E20, F40
- Harness for open or short between VVEL control shaft position sensor and VVEL control module

>> Repair open circuit, short to ground or short to power in harness or connectors.

## 5. CHECK INTERMITTENT INCIDENT

Refer to [GI-44, "Intermittent Incident"](#).

Is the inspection result normal?

YES >> GO TO 6.

NO >> Repair or replace.

## 6. REPLACE VVEL CONTROL MODULE

1. Replace VVEL control module.
2. Go to [EC-145, "Work Procedure"](#).

>> INSPECTION END

## 7. CHECK INTERMITTENT INCIDENT

Refer to [GI-44, "Intermittent Incident"](#).

Is the inspection result normal?

YES >> GO TO 8.

NO >> Repair or replace.

## 8. REPLACE VVEL ACTUATOR SUB ASSEMBLY

1. Replace VVEL actuator sub assembly.
2. Go to [EC-480, "Special Repair Requirement"](#).

>> INSPECTION END

## Special Repair Requirement

INFOID:000000006883133

## 1. PERFORM VVEL CONTROL SHAFT POSITION SENSOR ADJUSTMENT

Refer to [EC-151, "Work Procedure"](#).



# P1608 VVEL SENSOR POWER SUPPLY

< DTC/CIRCUIT DIAGNOSIS >

[VQ37VHR FOR USA AND CANADA]

>> GO TO 2.

## 2. PERFORM IDLE AIR VOLUME LEARNING

Refer to [EC-149, "Work Procedure"](#).

>> END

A

EC

C

D

E

F

G

H

I

J

K

L

M

N

O

P

# P1805 BRAKE SWITCH

< DTC/CIRCUIT DIAGNOSIS >

[VQ37VHR FOR USA AND CANADA]

## P1805 BRAKE SWITCH

### DTC Logic

INFOID:000000006883134

### DTC DETECTION LOGIC

| DTC No. | Trouble diagnosis name | DTC detecting condition   | Possible cause   |
|---------|------------------------|---|--|
| P1805   | Brake switch           | A brake switch signal is not sent to ECM for extremely long time while the vehicle is being driven. | <ul style="list-style-type: none"> <li>• Harness or connectors (Stop lamp switch circuit is open or shorted.)</li> <li>• Stop lamp switch</li> </ul> |

### DTC CONFIRMATION PROCEDURE

#### 1. PERFORM DTC CONFIRMATION PROCEDURE

1. Turn ignition switch ON.
2. Fully depress the brake pedal for at least 5 seconds.
3. Erase the DTC.
4. Check 1st trip DTC.

#### Is 1st trip DTC detected?

- YES >> Go to [EC-482, "Diagnosis Procedure"](#).
- NO >> INSPECTION END

### Diagnosis Procedure

INFOID:000000006883135

#### 1. CHECK STOP LAMP SWITCH CIRCUIT

1. Turn ignition switch OFF.
2. Check the stop lamp when depressing and releasing the brake pedal.

| Brake pedal        | Stop lamp       |
|--------------------|-----------------|
| Fully released     | Not illuminated |
| Slightly depressed | Illuminated     |

#### Is the inspection result normal?

- YES >> GO TO 4.
- NO >> GO TO 2.

#### 2. CHECK STOP LAMP SWITCH POWER SUPPLY CIRCUIT

1. Disconnect stop lamp switch harness connector.
2. Check the voltage between stop lamp switch harness connector and ground.

| Stop lamp switch |          | Ground | Voltage         |
|------------------|----------|--------|-----------------|
| Connector        | Terminal |        |                 |
| E110             | 1        | Ground | Battery voltage |

#### Is the inspection result normal?

- YES >> GO TO 4.
- NO >> GO TO 3.

#### 3. DETECT MALFUNCTIONING PART

Check the following.

- Fuse block (J/B) connector E103
- 10 A fuse (No. 7)
- Harness for open or short between stop lamp switch and battery

>> Repair open circuit, short to ground or short to power in harness or connectors.

#### 4. CHECK STOP LAMP SWITCH INPUT SIGNAL CIRCUIT FOR OPEN AND SHORT

# P1805 BRAKE SWITCH

[VQ37VHR FOR USA AND CANADA]

## < DTC/CIRCUIT DIAGNOSIS >

1. Disconnect stop lamp switch harness connector.
2. Disconnect ECM harness connector.
3. Check the continuity between stop lamp switch harness connector and ECM harness connector.

| Stop lamp switch |          | ECM       |          | Continuity |
|------------------|----------|-----------|----------|------------|
| Connector        | Terminal | Connector | Terminal |            |
| E110             | 2        | M107      | 122      | Existed    |

4. Also check harness for short to ground and short to power.

### Is the inspection result normal?

YES >> GO TO 6.

NO >> GO TO 5.

## 5. DETECT MALFUNCTIONING PART

Check the following.

- Fuse block (J/B) connector E103, M2
- Harness for open or short between ECM and stop lamp switch

>> Repair open circuit, short to ground or short to power in harness or connectors.

## 6. CHECK STOP LAMP SWITCH

Refer to [EC-483, "Component Inspection \(Stop Lamp Switch\)"](#).

### Is the inspection result normal?

YES >> GO TO 7.

NO >> Replace stop lamp switch. Refer to [BR-18, "Exploded View"](#).

## 7. CHECK INTERMITTENT INCIDENT

Refer to [GI-44, "Intermittent Incident"](#).

>> INSPECTION END

## Component Inspection (Stop Lamp Switch)

INFOID:000000006883136

### 1. CHECK STOP LAMP SWITCH-I

1. Turn ignition switch OFF.
2. Disconnect stop lamp switch harness connector.
3. Check the continuity between stop lamp switch terminals under the following conditions.

| Terminals | Condition   |                    | Continuity  |
|-----------|-------------|--------------------|-------------|
| 1 and 2   | Brake pedal | Fully released     | Not existed |
|           |             | Slightly depressed | Existed     |

### Is the inspection result normal?

YES >> INSPECTION END

NO >> GO TO 2.

### 2. CHECK STOP LAMP SWITCH-II

1. Adjust stop lamp switch installation. Refer to [BR-19, "Inspection and Adjustment"](#).
2. Check the continuity between stop lamp switch terminals under the following conditions.

| Terminals | Condition   |                    | Continuity  |
|-----------|-------------|--------------------|-------------|
| 1 and 2   | Brake pedal | Fully released     | Not existed |
|           |             | Slightly depressed | Existed     |

### Is the inspection result normal?

YES >> INSPECTION END

## P1805 BRAKE SWITCH

< DTC/CIRCUIT DIAGNOSIS >

[VQ37VHR FOR USA AND CANADA]

---

NO >> Replace stop lamp switch. Refer to [BR-18. "Exploded View"](#).

# P2122, P2123 APP SENSOR

< DTC/CIRCUIT DIAGNOSIS >

[VQ37VHR FOR USA AND CANADA]

## P2122, P2123 APP SENSOR

### DTC Logic

INFOID:000000006883137

#### DTC DETECTION LOGIC

##### NOTE:

If DTC P2122 or P2123 is displayed with DTC P0643, first perform the trouble diagnosis for DTC P0643. Refer to [EC-388, "DTC Logic"](#).

| DTC No. | Trouble diagnosis name                                 | DTC detecting condition   | Possible cause   |
|---------|--|---|--|
| P2122   | Accelerator pedal position sensor 1 circuit low input  | An excessively low voltage from the APP sensor 1 is sent to ECM.  | <ul style="list-style-type: none"> <li>Harness or connectors (APP sensor 1 circuit is open or shorted.)</li> </ul> |
| P2123   | Accelerator pedal position sensor 1 circuit high input | An excessively high voltage from the APP sensor 1 is sent to ECM. | <ul style="list-style-type: none"> <li>Accelerator pedal position sensor (APP sensor 1)</li> </ul>                 |

#### DTC CONFIRMATION PROCEDURE

##### 1. PRECONDITIONING

If DTC Confirmation Procedure has been previously conducted, always perform the following procedure before conducting the next test.

- Turn ignition switch OFF and wait at least 10 seconds.
- Turn ignition switch ON.
- Turn ignition switch OFF and wait at least 10 seconds.

##### TESTING CONDITION:

Before performing the following procedure, confirm that battery voltage is more than 10 V at idle.

>> GO TO 2.

##### 2. PERFORM DTC CONFIRMATION PROCEDURE

- Start engine and let it idle for 1 second.
- Check DTC.

Is DTC detected?

- YES >> Go to [EC-485, "Diagnosis Procedure"](#).  
 NO >> INSPECTION END

#### Diagnosis Procedure

INFOID:000000006883138

##### 1. CHECK GROUND CONNECTION

- Turn ignition switch OFF.
- Check ground connection M95. Refer to Ground Inspection in [GI-47, "Circuit Inspection"](#).

Is the inspection result normal?

- YES >> GO TO 2.  
 NO >> Repair or replace ground connection.

##### 2. CHECK APP SENSOR 1 POWER SUPPLY CIRCUIT

- Disconnect accelerator pedal position (APP) sensor harness connector.
- Turn ignition switch ON.
- Check the voltage between APP sensor harness connector and ground.

| APP sensor |          | Ground | Voltage (V) |
|------------|----------|--------|-------------|
| Connector  | Terminal |        |             |
| M153*1     | 6*1      | Ground | Approx. 5   |
| M9*2       | 5*2      |        |             |

\*1: With ICC

\*2: Without ICC

Is the inspection result normal?

## P2122, P2123 APP SENSOR

[VQ37VHR FOR USA AND CANADA]

### < DTC/CIRCUIT DIAGNOSIS >

- YES >> GO TO 4.  
NO >> GO TO 3.

### 3.DETECT MALFUNCTIONING PART

Check the following.

- Harness connectors M6, E106
- Harness for open or short between ECM and accelerator pedal position sensor

>> Repair open circuit, short to ground or short to power in harness or connectors.

### 4.CHECK APP SENSOR 1 GROUND CIRCUIT FOR OPEN AND SHORT

1. Turn ignition switch OFF.
2. Disconnect ECM harness connector.
3. Check the continuity between APP sensor harness connector and ECM harness connector.

| APP sensor                             |                                    | ECM       |          | Continuity |
|--|------------------------------------|-----------|----------|------------|
| Connector                              | Terminal                           | Connector | Terminal |            |
| M153 <sup>*1</sup><br>M9 <sup>*2</sup> | 5 <sup>*1</sup><br>4 <sup>*2</sup> | M107      | 100      | Existed    |

\*1: With ICC

\*2: Without ICC

4. Also check harness for short to ground and short to power.

Is the inspection result normal?

- YES >> GO TO 6.  
NO >> GO TO 5 (With ICC).  
NO >> Repair open circuit, short to ground or short to power in harness or connectors (Without ICC).

### 5.DETECT MALFUNCTIONING PART

Check the following.

- Harness connectors M150, M151
- Harness for open or short between ECM and accelerator pedal position sensor

>> Repair open circuit, short to ground or short to power in harness or connectors.

### 6.CHECK APP SENSOR INPUT SIGNAL CIRCUIT FOR OPEN AND SHORT

1. Check the continuity between APP sensor harness connector and ECM harness connector.

| APP sensor                             |                                    | ECM       |          | Continuity |
|--|------------------------------------|-----------|----------|------------|
| Connector                              | Terminal                           | Connector | Terminal |            |
| M153 <sup>*1</sup><br>M9 <sup>*2</sup> | 4 <sup>*1</sup><br>3 <sup>*2</sup> | M107      | 97       | Existed    |

\*1: With ICC

\*2: Without ICC

2. Also check harness for short to ground and short to power.

Is the inspection result normal?

- YES >> GO TO 8.  
NO >> GO TO 7 (With ICC).  
NO >> Repair open circuit, short to ground or short to power in harness or connectors (Without ICC).

### 7.DETECT MALFUNCTIONING PART

Check the following.

- Harness connectors M150, M151
- Harness for open or short between ECM and accelerator pedal position sensor

>> Repair open circuit, short to ground or short to power in harness or connectors.

# P2122, P2123 APP SENSOR

[VQ37VHR FOR USA AND CANADA]

< DTC/CIRCUIT DIAGNOSIS >

## 8. CHECK APP SENSOR

Refer to [EC-487, "Component Inspection"](#).

Is the inspection result normal?

YES >> GO TO 10.

NO >> GO TO 9.

## 9. REPLACE ACCELERATOR PEDAL ASSEMBLY

1. Replace accelerator pedal assembly.
2. Go to [EC-487, "Special Repair Requirement"](#).

>> INSPECTION END

## 10. CHECK INTERMITTENT INCIDENT

Refer to [GI-44, "Intermittent Incident"](#).

>> INSPECTION END

## Component Inspection

INFOID:000000006883139

### 1. CHECK ACCELERATOR PEDAL POSITION SENSOR

1. Turn ignition switch OFF.
2. Reconnect all harness connectors disconnected.
3. Turn ignition switch ON.
4. Check the voltage ECM harness connector terminals as per the following.

| ECM       |                   |          | Condition       | Voltage (V) |
|-----------|-------------------|----------|-----------------|-------------|
| Connector | +                 | -        |                 |             |
|           | Terminal          | Terminal |                 |             |
| M107      | 97 (APP sensor 1) | 100      | Fully released  | 0.45 - 1.0  |
|           |                   |          | Fully depressed | 4.2 - 4.8   |
|           | 98 (APP sensor 2) | 104      | Fully released  | 0.22 - 0.50 |
|           |                   |          | Fully depressed | 2.1 - 2.5   |

Is the inspection result normal?

YES >> INSPECTION END

NO >> GO TO 2.

### 2. REPLACE ACCELERATOR PEDAL ASSEMBLY

1. Replace accelerator pedal assembly.
2. Go to [EC-487, "Special Repair Requirement"](#).

>> INSPECTION END

## Special Repair Requirement

INFOID:000000006883140

### 1. PERFORM ACCELERATOR PEDAL RELEASED POSITION LEARNING

Refer to [EC-147, "Work Procedure"](#).

>> GO TO 2.

### 2. PERFORM THROTTLE VALVE CLOSED POSITION LEARNING

Refer to [EC-148, "Work Procedure"](#).

>> GO TO 3.

## P2122, P2123 APP SENSOR

< DTC/CIRCUIT DIAGNOSIS >

[VQ37VHR FOR USA AND CANADA]

---

### 3.PERFORM IDLE AIR VOLUME LEARNING

---

Refer to [EC-149, "Work Procedure"](#).

>> END



# P2127, P2128 APP SENSOR

< DTC/CIRCUIT DIAGNOSIS >

[VQ37VHR FOR USA AND CANADA]

## P2127, P2128 APP SENSOR

### DTC Logic

INFOID:000000006883141

### DTC DETECTION LOGIC

| DTC No. | Trouble diagnosis name                                 | DTC detecting condition   | Possible cause  |
|---------|--|---|---|
| P2127   | Accelerator pedal position sensor 2 circuit low input  | An excessively low voltage from the APP sensor 2 is sent to ECM.  | <ul style="list-style-type: none"><li>• Harness or connectors (APP sensor 2 circuit is open or shorted.) [CKP sensor (POS) circuit is shorted.] [CMP sensor (PHASE) (bank 2) circuit is open or shorted.] (Battery current sensor circuit is open or shorted.) (EVAP control system pressure sensor circuit is shorted.) (Refrigerant pressure sensor circuit is shorted.)</li><li>• Accelerator pedal position sensor (APP sensor 2)</li><li>• Crankshaft position sensor (POS)</li><li>• Camshaft position sensor (PHASE) (bank 2)</li><li>• Battery current sensor</li><li>• EVAP control system pressure sensor</li><li>• Refrigerant pressure sensor</li></ul> |
| P2128   | Accelerator pedal position sensor 2 circuit high input | An excessively high voltage from the APP sensor 2 is sent to ECM. |   |

### DTC CONFIRMATION PROCEDURE

#### 1. PRECONDITIONING

If DTC Confirmation Procedure has been previously conducted, always perform the following procedure before conducting the next test.

1. Turn ignition switch OFF and wait at least 10 seconds.
2. Turn ignition switch ON.
3. Turn ignition switch OFF and wait at least 10 seconds.

#### TESTING CONDITION:

Before performing the following procedure, confirm that battery voltage is more than 10 V at idle.

>> GO TO 2.

#### 2. PERFORM DTC CONFIRMATION PROCEDURE

1. Start engine and let it idle for 1 second.
2. Check DTC.

Is DTC detected?

- YES >> Go to [EC-489, "Diagnosis Procedure"](#).  
NO >> INSPECTION END

### Diagnosis Procedure

INFOID:000000006883142

#### 1. CHECK GROUND CONNECTION

1. Turn ignition switch OFF.
2. Check ground connection M95. Refer to Ground Inspection in [GI-47, "Circuit Inspection"](#).

Is the inspection result normal?

- YES >> GO TO 2.  
NO >> Repair or replace ground connection.

#### 2. CHECK APP SENSOR 2 POWER SUPPLY CIRCUIT-I

1. Disconnect accelerator pedal position (APP) sensor harness connector.
2. Turn ignition switch ON.
3. Check the voltage between APP sensor harness connector and ground.

# P2127, P2128 APP SENSOR

< DTC/CIRCUIT DIAGNOSIS >

[VQ37VHR FOR USA AND CANADA]

| APP sensor                             |                                    | Ground | Voltage (V) |
|--|------------------------------------|--------|-------------|
| Connector                              | Terminal                           |        |             |
| M153 <sup>*1</sup><br>M9 <sup>*2</sup> | 3 <sup>*1</sup><br>6 <sup>*2</sup> | Ground | Approx. 5   |

\*1: With ICC

\*2: Without ICC

Is the inspection result normal?

YES >> GO TO 7.

NO >> GO TO 3.

## 3.CHECK APP SENSOR 2 POWER SUPPLY CIRCUIT-II

1. Turn ignition switch OFF.
2. Disconnect ECM harness connector.
3. Check the continuity between APP sensor harness connector and ECM harness connector.

| APP sensor                             |                                    | ECM       |          | Continuity |
|--|------------------------------------|-----------|----------|------------|
| Connector                              | Terminal                           | Connector | Terminal |            |
| M153 <sup>*1</sup><br>M9 <sup>*2</sup> | 3 <sup>*1</sup><br>6 <sup>*2</sup> | M107      | 103      | Existed    |

\*1: With ICC

\*2: Without ICC

Is the inspection result normal?

YES >> GO TO 5.

NO >> GO TO 4 (With ICC).

NO >> Repair open circuit, short to ground or short to power in harness or connectors (Without ICC).

## 4.DETECT MALFUNCTIONING PART

Check the following.

- Harness connectors M150, M151
- Harness for open or short between ECM and accelerator pedal position sensor

>> Repair open circuit, short to ground or short to power in harness or connectors.

## 5.CHECK SENSOR POWER SUPPLY CIRCUIT

Check harness for short to power and short to ground, between the following terminals.

| ECM       |          | Sensor                              |  |                                    |
|-----------|----------|-------------------------------------|--|------------------------------------|
| Connector | Terminal | Name                                | Connector                              | Terminal                           |
| F101      | 46       | CKP sensor (POS)                    | F2                                     | 1                                  |
| F102      | 64       | CMP sensor (PHASE) (bank 2)         | F18                                    | 1                                  |
|           |          | Battery current sensor              | E21                                    |                                    |
| M107      | 103      | APP sensor                          | M153 <sup>*1</sup><br>M9 <sup>*2</sup> | 3 <sup>*1</sup><br>6 <sup>*2</sup> |
|           |          | EVAP control system pressure sensor | B73                                    | 3                                  |
|           | 107      | Refrigerant pressure sensor         | E77                                    | 3                                  |

\*1: With ICC

\*2: Without ICC

Is the inspection result normal?

YES >> GO TO 6.

NO >> Repair short to ground or short to power in harness or connectors.

# P2127, P2128 APP SENSOR

< DTC/CIRCUIT DIAGNOSIS >

[VQ37VHR FOR USA AND CANADA]

## 6. CHECK COMPONENTS

Check the following.

- Crankshaft position sensor (POS) (Refer to [EC-314, "Component Inspection"](#).)
- Camshaft position sensor (PHASE) (bank 2) (Refer to [EC-319, "Component Inspection"](#).)
- Battery current sensor (Refer to [EC-437, "Component Inspection"](#).)
- EVAP control system pressure sensor (Refer to [EC-349, "Component Inspection"](#).)
- Refrigerant pressure sensor (Refer to [EC-530, "Diagnosis Procedure"](#).)

Is the inspection result normal?

YES >> GO TO 13.

NO >> Replace malfunctioning component.

## 7. CHECK APP SENSOR 2 GROUND CIRCUIT FOR OPEN AND SHORT

1. Turn ignition switch OFF.
2. Disconnect ECM harness connector.
3. Check the continuity between APP sensor harness connector and ECM harness connector.

| APP sensor     |          | ECM       |          | Continuity |
|----------------|----------|-----------|----------|------------|
| Connector      | Terminal | Connector | Terminal |            |
| M153*1<br>M9*2 | 2        | M107      | 104      | Existed    |

\*1: With ICC

\*2: Without ICC

4. Also check harness for short to ground and short to power.

Is the inspection result normal?

YES >> GO TO 9.

NO >> GO TO 8 (With ICC).

NO >> Repair open circuit, short to ground or short to power in harness or connectors (Without ICC).

## 8. DETECT MALFUNCTIONING PART

Check the following.

- Harness connectors M150, M151
- Harness for open or short between ECM and accelerator pedal position sensor

>> Repair open circuit, short to ground or short to power in harness or connectors.

## 9. CHECK APP SENSOR 2 INPUT SIGNAL CIRCUIT FOR OPEN AND SHORT

1. Check the continuity between APP sensor harness connector and ECM harness connector.

| APP sensor     |          | ECM       |          | Continuity |
|----------------|----------|-----------|----------|------------|
| Connector      | Terminal | Connector | Terminal |            |
| M153*1<br>M9*2 | 1        | M107      | 98       | Existed    |

\*1: With ICC

\*2: Without ICC

2. Also check harness for short to ground and short to power.

Is the inspection result normal?

YES >> GO TO 11.

NO >> GO TO 10 (With ICC).

NO >> Repair open circuit, short to ground or short to power in harness or connectors (Without ICC).

## 10. DETECT MALFUNCTIONING PART

Check the following.

- Harness connectors M150, M151
- Harness for open or short between ECM and accelerator pedal position sensor

>> Repair open circuit, short to ground or short to power in harness or connectors.

**11. CHECK APP SENSOR**

Refer to [EC-492, "Component Inspection"](#).

Is the inspection result normal?

- YES >> GO TO 13.
- NO >> GO TO 12.

**12. REPLACE ACCELERATOR PEDAL ASSEMBLY**

1. Replace accelerator pedal assembly.
2. Go to [EC-492, "Special Repair Requirement"](#).

>> INSPECTION END

**13. CHECK INTERMITTENT INCIDENT**

Refer to [GI-44, "Intermittent Incident"](#).

>> INSPECTION END

**Component Inspection**

INFOID:000000006883143

**1. CHECK ACCELERATOR PEDAL POSITION SENSOR**

1. Turn ignition switch OFF.
2. Reconnect all harness connectors disconnected.
3. Turn ignition switch ON.
4. Check the voltage ECM harness connector terminals as per the following.

| ECM       |                   |          | Condition       | Voltage (V) |
|-----------|-------------------|----------|-----------------|-------------|
| Connector | +                 | -        |                 |             |
|           | Terminal          | Terminal |                 |             |
| M107      | 97 (APP sensor 1) | 100      | Fully released  | 0.45 - 1.0  |
|           |                   |          | Fully depressed | 4.2 - 4.8   |
|           | 98 (APP sensor 2) | 104      | Fully released  | 0.22 - 0.50 |
|           |                   |          | Fully depressed | 2.1 - 2.5   |

Is the inspection result normal?

- YES >> INSPECTION END
- NO >> GO TO 2.

**2. REPLACE ACCELERATOR PEDAL ASSEMBLY**

1. Replace accelerator pedal assembly.
2. Go to [EC-487, "Special Repair Requirement"](#).

>> INSPECTION END

**Special Repair Requirement**

INFOID:000000006883144

**1. PERFORM ACCELERATOR PEDAL RELEASED POSITION LEARNING**

Refer to [EC-147, "Work Procedure"](#).

>> GO TO 2.

**2. PERFORM THROTTLE VALVE CLOSED POSITION LEARNING**

Refer to [EC-148, "Work Procedure"](#).

# P2127, P2128 APP SENSOR

< DTC/CIRCUIT DIAGNOSIS >

[VQ37VHR FOR USA AND CANADA]

>> GO TO 3.

## 3.PERFORM IDLE AIR VOLUME LEARNING

Refer to [EC-149. "Work Procedure"](#).

>> END

A

EC

C

D

E

F

G

H

I

J

K

L

M

N

O

P

# P2138 APP SENSOR

< DTC/CIRCUIT DIAGNOSIS >

[VQ37VHR FOR USA AND CANADA]

## P2138 APP SENSOR

### DTC Logic

INFOID:000000006883145

#### DTC DETECTION LOGIC

##### NOTE:

If DTC P2138 is displayed with DTC P0643, first perform the trouble diagnosis for DTC P0643. Refer to [EC-388, "DTC Logic"](#).

| DTC No. | Trouble diagnosis name                                      | DTC detecting condition   | Possible cause  |
|---------|---|---|---|
| P2138   | Accelerator pedal position sensor circuit range/performance | Rationally incorrect voltage is sent to ECM compared with the signals from APP sensor 1 and APP sensor 2. | <ul style="list-style-type: none"><li>• Harness or connectors<br/>(APP sensor 2 circuit is open or shorted.)<br/>[CKP sensor (POS) circuit is shorted.]<br/>[CMP sensor (PHASE) (bank 2) circuit is open or shorted.]<br/>(Battery current sensor circuit is open or shorted.)<br/>(EVAP control system pressure sensor circuit is shorted.)<br/>(Refrigerant pressure sensor circuit is shorted.)</li><li>• Accelerator pedal position sensor (APP sensor 2)</li><li>• Crankshaft position sensor (POS)</li><li>• Camshaft position sensor (PHASE) (bank 2)</li><li>• Battery current sensor</li><li>• EVAP control system pressure sensor</li><li>• Refrigerant pressure sensor</li></ul> |

#### DTC CONFIRMATION PROCEDURE

##### 1. PRECONDITIONING

If DTC Confirmation Procedure has been previously conducted, always perform the following procedure before conducting the next test.

1. Turn ignition switch OFF and wait at least 10 seconds.
2. Turn ignition switch ON.
3. Turn ignition switch OFF and wait at least 10 seconds.

##### TESTING CONDITION:

Before performing the following procedure, confirm that battery voltage is more than 10 V at idle.

>> GO TO 2.

##### 2. PERFORM DTC CONFIRMATION PROCEDURE

1. Start engine and let it idle for 1 second.
2. Check DTC.

##### Is DTC detected?

- YES >> Go to [EC-494, "Diagnosis Procedure"](#).  
NO >> INSPECTION END

#### Diagnosis Procedure

INFOID:000000006883146

##### 1. CHECK GROUND CONNECTION

1. Turn ignition switch OFF.
2. Check ground connection M95. Refer to Ground Inspection in [GI-47, "Circuit Inspection"](#).

##### Is the inspection result normal?

- YES >> GO TO 2.  
NO >> Repair or replace ground connection.

##### 2. CHECK APP SENSOR 1 POWER SUPPLY CIRCUIT

1. Disconnect accelerator pedal position (APP) sensor harness connector.
2. Turn ignition switch ON.
3. Check the voltage between APP sensor harness connector and ground.

# P2138 APP SENSOR

< DTC/CIRCUIT DIAGNOSIS >

[VQ37VHR FOR USA AND CANADA]

| APP sensor                             |                                    | Ground | Voltage (V) |
|--|------------------------------------|--------|-------------|
| Connector                              | Terminal                           |        |             |
| M153 <sup>*1</sup><br>M9 <sup>*2</sup> | 6 <sup>*1</sup><br>5 <sup>*2</sup> | Ground | Approx. 5   |

\*1: With ICC

\*2: Without ICC

Is the inspection result normal?

YES >> GO TO 4.

NO >> GO TO 3 (With ICC).

NO >> Repair open circuit, short to ground or short to power in harness or connectors (Without ICC).

## 3. DETECT MALFUNCTIONING PART

Check the following.

- Harness connectors M150, M151
- Harness for open or short between ECM and accelerator pedal position sensor

>> Repair open circuit, short to ground or short to power in harness or connectors.

## 4. CHECK APP SENSOR 2 POWER SUPPLY CIRCUIT-I

1. Turn ignition switch ON.
2. Check the voltage between APP sensor harness connector and ground.

| APP sensor                             |                                    | Ground | Voltage (V) |
|--|------------------------------------|--------|-------------|
| Connector                              | Terminal                           |        |             |
| M153 <sup>*1</sup><br>M9 <sup>*2</sup> | 3 <sup>*1</sup><br>6 <sup>*2</sup> | Ground | Approx. 5   |

\*1: With ICC

\*2: Without ICC

Is the inspection result normal?

YES >> GO TO 9.

NO >> GO TO 5.

## 5. CHECK APP SENSOR 2 POWER SUPPLY CIRCUIT-II

1. Turn ignition switch OFF.
2. Disconnect ECM harness connector.
3. Check the continuity between APP sensor harness connector and ECM harness connector.

| APP sensor                             |                                    | ECM       |          | Continuity |
|--|------------------------------------|-----------|----------|------------|
| Connector                              | Terminal                           | Connector | Terminal |            |
| M153 <sup>*1</sup><br>M9 <sup>*2</sup> | 3 <sup>*1</sup><br>6 <sup>*2</sup> | M107      | 103      | Existed    |

\*1: With ICC

\*2: Without ICC

Is the inspection result normal?

YES >> GO TO 7.

NO >> GO TO 6 (With ICC).

NO >> Repair open circuit, short to ground or short to power in harness or connectors (Without ICC).

## 6. DETECT MALFUNCTIONING PART

Check the following.

- Harness connectors M105, M151
- Harness for open or short between ECM and accelerator pedal position sensor

# P2138 APP SENSOR

< DTC/CIRCUIT DIAGNOSIS >

[VQ37VHR FOR USA AND CANADA]

>> Repair open circuit, short to ground or short to power in harness or connectors.

## 7. CHECK SENSOR POWER SUPPLY CIRCUIT

Check harness for short to power and short to ground, between the following terminals.

| ECM       |          | Sensor                              |                |            |
|-----------|----------|-------------------------------------|----------------|------------|
| Connector | Terminal | Name                                | Connector      | Terminal   |
| F101      | 46       | CKP sensor (POS)                    | F2             | 1          |
| F102      | 64       | CMP sensor (PHASE) (bank 2)         | F18            | 1          |
|           |          | Battery current sensor              | E21            |            |
| M107      | 103      | APP sensor                          | M153*1<br>M9*2 | 3*1<br>6*2 |
|           |          | EVAP control system pressure sensor | B73            | 3          |
|           | 107      | Refrigerant pressure sensor         | E77            | 3          |

\*1: With ICC

\*2: Without ICC

Is the inspection result normal?

YES >> GO TO 8.

NO >> Repair short to ground or short to power in harness or connectors.

## 8. CHECK COMPONENTS

Check the following.

- Crankshaft position sensor (POS) (Refer to [EC-314, "Component Inspection"](#).)
- Camshaft position sensor (PHASE) (bank 2) (Refer to [EC-319, "Component Inspection"](#).)
- Battery current sensor (Refer to [EC-437, "Component Inspection"](#).)
- EVAP control system pressure sensor (Refer to [EC-349, "Component Inspection"](#).)
- Refrigerant pressure sensor (Refer to [EC-530, "Diagnosis Procedure"](#).)

Is the inspection result normal?

YES >> GO TO 15.

NO >> Replace malfunctioning component.

## 9. CHECK APP SENSOR GROUND CIRCUIT FOR OPEN AND SHORT

1. Turn ignition switch OFF.
2. Disconnect ECM harness connector.
3. Check the continuity between APP sensor harness connector and ECM harness connector.

| APP sensor     |          | ECM       |          | Continuity |
|----------------|----------|-----------|----------|------------|
| Connector      | Terminal | Connector | Terminal |            |
| M153*1<br>M9*2 | 5*1      | M107      | 100      | Existed    |
|                | 4*2      |           | 104      |            |
|                | 2        |           |          |            |

\*1: With ICC

\*2: Without ICC

4. Also check harness for short to ground and short to power.

Is the inspection result normal?

YES >> GO TO 11.

NO >> GO TO 10 (With ICC).

NO >> Repair open circuit, short to ground or short to power in harness or connectors (Without ICC).

## 10. DETECT MALFUNCTIONING PART

Check the following.

- Harness connectors M150, M151



# P2138 APP SENSOR

< DTC/CIRCUIT DIAGNOSIS >

[VQ37VHR FOR USA AND CANADA]

- Harness for open or short between ECM and accelerator pedal position sensor

>> Repair open circuit, short to ground or short to power in harness or connectors.

## 11. CHECK APP SENSOR INPUT SIGNAL CIRCUIT FOR OPEN AND SHORT

1. Check the continuity between APP sensor harness connector and ECM harness connector.

| APP sensor                             |                 | ECM       |          | Continuity |
|--|-----------------|-----------|----------|------------|
| Connector                              | Terminal        | Connector | Terminal |            |
| M153 <sup>*1</sup><br>M9 <sup>*2</sup> | 4 <sup>*1</sup> | M107      | 97       | Existed    |
|  | 3 <sup>*2</sup> |           | 98       |            |
|  | 1               |           |          |            |

\*1: With ICC

\*2: Without ICC

2. Also check harness for short to ground and short to power.

Is the inspection result normal?

YES >> GO TO 13.

NO >> GO TO 12 (With ICC).

NO >> Repair open circuit, short to ground or short to power in harness or connectors (Without ICC).

## 12. DETECT MALFUNCTIONING PART

Check the following.

- Harness connectors M150, M151
- Harness for open or short between ECM and accelerator pedal position sensor

>> Repair open circuit, short to ground or short to power in harness or connectors.

## 13. CHECK APP SENSOR

Refer to [EC-497, "Component Inspection"](#).

Is the inspection result normal?

YES >> GO TO 15.

NO >> GO TO 14.

## 14. REPLACE ACCELERATOR PEDAL ASSEMBLY

1. Replace accelerator pedal assembly.
2. Go to [EC-498, "Special Repair Requirement"](#).

>> INSPECTION END

## 15. CHECK INTERMITTENT INCIDENT

Refer to [GI-44, "Intermittent Incident"](#).

>> INSPECTION END

## Component Inspection

INFOID:0000000006883147

### 1. CHECK ACCELERATOR PEDAL POSITION SENSOR

1. Turn ignition switch OFF.
2. Reconnect all harness connectors disconnected.
3. Turn ignition switch ON.
4. Check the voltage ECM harness connector terminals as per the following.

# P2138 APP SENSOR

< DTC/CIRCUIT DIAGNOSIS >

[VQ37VHR FOR USA AND CANADA]

| ECM       |                   |          | Condition         | Voltage (V)     |             |
|-----------|-------------------|----------|-------------------|-----------------|-------------|
| Connector | +                 | -        |                   |                 |             |
|           | Terminal          | Terminal |                   |                 |             |
| M107      | 97 (APP sensor 1) | 100      | Accelerator pedal | Fully released  | 0.45 - 1.0  |
|           |                   |          |                   | Fully depressed | 4.2 - 4.8   |
|           | 98 (APP sensor 2) | 104      |                   | Fully released  | 0.22 - 0.50 |
|           |                   |          |                   | Fully depressed | 2.1 - 2.5   |

Is the inspection result normal?

YES >> INSPECTION END

NO >> GO TO 2.

## 2. REPLACE ACCELERATOR PEDAL ASSEMBLY

1. Replace accelerator pedal assembly.
2. Go to [EC-487, "Special Repair Requirement"](#).

>> INSPECTION END

## Special Repair Requirement

INFOID:000000006883148

## 1. PERFORM ACCELERATOR PEDAL RELEASED POSITION LEARNING

Refer to [EC-147, "Work Procedure"](#).

>> GO TO 2.

## 2. PERFORM THROTTLE VALVE CLOSED POSITION LEARNING

Refer to [EC-148, "Work Procedure"](#).

>> GO TO 3.

## 3. PERFORM IDLE AIR VOLUME LEARNING

Refer to [EC-149, "Work Procedure"](#).

>> END

# P2A00, P2A03 A/F SENSOR 1

< DTC/CIRCUIT DIAGNOSIS >

[VQ37VHR FOR USA AND CANADA]

## P2A00, P2A03 A/F SENSOR 1

### DTC Logic

INFOID:000000006883149

#### DTC DETECTION LOGIC

To judge the malfunction, the A/F signal computed by ECM from the A/F sensor 1 signal is monitored not it will shift to LEAN side or RICH side.

| DTC No. | Trouble diagnosis name   | DTC detecting condition   | Possible Cause   |
|---------|--|---|--|
| P2A00   | Air fuel ratio (A/F) sensor 1 (bank 1) circuit range/performance | <ul style="list-style-type: none"><li>The output voltage computed by ECM from the A/F sensor 1 signal is shifts to the lean side for a specified period.</li><li>The A/F signal computed by ECM from the A/F sensor 1 signal is shifts to the rich side for a specified period.</li></ul> | <ul style="list-style-type: none"><li>A/F sensor 1</li><li>A/F sensor 1 heater</li><li>Heated oxygen sensor 2</li><li>Fuel pressure</li><li>Fuel injector</li><li>Intake air leaks</li><li>Exhaust gas leaks</li></ul> |
| P2A03   | Air fuel ratio (A/F) sensor 1 (bank 2) circuit range/performance |   |  |

#### DTC CONFIRMATION PROCEDURE

##### 1. PRECONDITIONING

If DTC Confirmation Procedure has been previously conducted, always perform the following procedure before conducting the next test.

- Turn ignition switch OFF and wait at least 10 seconds.
- Turn ignition switch ON.
- Turn ignition switch OFF and wait at least 10 seconds.

##### TESTING CONDITION:

Before performing the following procedure, confirm that battery voltage is more than 11 V at idle.

>> GO TO 2.

##### 2. PERFORM DTC CONFIRMATION PROCEDURE

- Clear the mixture ratio self-learning value. Refer to [EC-153, "Work Procedure"](#).
- Turn ignition switch OFF and wait at least 10 seconds.
- Turn ignition switch ON.
- Turn ignition switch OFF and wait at least 10 seconds.
- Start engine and keep the engine speed between 3,500 and 4,000 rpm for 1 minute under no load.
- Let engine idle for 1 minute.
- Keep engine speed between 2,500 and 3,000 rpm for 20 minutes.
- Check 1st trip DTC.

##### Is 1st trip DTC detected?

- YES >> Go to [EC-499, "Diagnosis Procedure"](#).  
NO >> INSPECTION END

#### Diagnosis Procedure

INFOID:000000006883150

##### 1. CHECK GROUND CONNECTION

- Turn ignition switch OFF.
- Check ground connection M95. Refer to Ground Inspection in [GI-47, "Circuit Inspection"](#).

##### Is the inspection result normal?

- YES >> GO TO 2.  
NO >> Repair or replace ground connection.

##### 2. RETIGHTEN A/F SENSOR 1 AND HEATED OXYGEN SENSOR 2

- Loosen and retighten the A/F sensor 1 and heated oxygen sensor 2. Refer to [EM-36, "Removal and Installation"](#).

>> GO TO 3.

# P2A00, P2A03 A/F SENSOR 1

[VQ37VHR FOR USA AND CANADA]

< DTC/CIRCUIT DIAGNOSIS >

## 3. CHECK FOR EXHAUST GAS LEAK

1. Start engine and run it at idle.
2. Listen for an exhaust gas leak before the three way catalyst 2.

Is exhaust gas detected?

- YES >> Repair or replace.  
NO >> GO TO 4.

## 4. CHECK FOR INTAKE AIR LEAK

1. Start engine and run it at idle.
2. Listen for an intake air leak after the mass air flow sensor.

Is intake air leak detected?

- YES >> Repair or replace.  
NO >> GO TO 5.

## 5. CLEAR THE MIXTURE RATIO SELF-LEARNING VALUE

1. Clear the mixture ratio self-learning value. Refer to [EC-153, "Work Procedure"](#).
2. Run engine for at least 10 minutes at idle speed.

Is the 1st trip DTC P0171, P0172, P0174 or P0175 detected? Is it difficult to start engine?

- YES >> Perform trouble diagnosis for DTC P0171, P0174 or P0172, P0175. Refer to [EC-280, "Diagnosis Procedure"](#) or [EC-284, "Diagnosis Procedure"](#).  
NO >> GO TO 6.

## 6. CHECK HARNESS CONNECTOR

1. Turn ignition switch OFF.
2. Disconnect A/F sensor 1 harness connector.
3. Check harness connector for water.

**Water should not exit.**

Is the inspection result normal?

- YES >> GO TO 7.  
NO >> Repair or replace harness connector.

## 7. CHECK A/F SENSOR 1 POWER SUPPLY CIRCUIT

1. Turn ignition switch ON.
2. Check the voltage between A/F sensor 1 harness connector and ground.

| DTC   | A/F sensor 1 |           |          | Ground | Voltage         |
|-------|--------------|-----------|----------|--------|-----------------|
|       | Bank         | Connector | Terminal |        |                 |
| P2A00 | 1            | F3        | 4        | Ground | Battery voltage |
| P2A03 | 2            | F20       | 4        |        |                 |

Is the inspection result normal?

- YES >> GO TO 9.  
NO >> GO TO 8.

## 8. DETECT MALFUNCTIONING PART

Check the following.

- Harness connectors E20, F40
- IPDM E/R harness connector E7
- 15 A fuse (No. 45)
- Harness for open or short between A/F sensor 1 and fuse

>> Repair or replace harness or connectors.

## 9. CHECK A/F SENSOR 1 INPUT SIGNAL CIRCUIT FOR OPEN AND SHORT

1. Turn ignition switch OFF.

# P2A00, P2A03 A/F SENSOR 1

[VQ37VHR FOR USA AND CANADA]

## < DTC/CIRCUIT DIAGNOSIS >

2. Disconnect ECM harness connector.
3. Check the continuity between A/F sensor 1 harness connector and ECM harness connector.

| DTC   | A/F sensor 1 |           |          | ECM       |          | Continuity |
|-------|--------------|-----------|----------|-----------|----------|------------|
|       | Bank         | Connector | Terminal | Connector | Terminal |            |
| P2A00 | 1            | F3        | 1        | F102      | 57       | Existed    |
|       |              |           | 2        |           | 61       |            |
| P2A03 | 2            | F20       | 1        |           | 65       |            |
|       |              |           | 2        |           | 66       |            |

4. Check the continuity between A/F sensor 1 harness connector and ground, or ECM harness connector and ground.

| DTC   | A/F sensor 1 |           |          | Ground | Continuity  |
|-------|--------------|-----------|----------|--------|-------------|
|       | Bank         | Connector | Terminal |        |             |
| P2A00 | 1            | F3        | 1        | Ground | Not existed |
|       |              |           | 2        |        |             |
| P2A03 | 2            | F20       | 1        |        |             |
|       |              |           | 2        |        |             |

| DTC   | ECM  |           |          | Ground | Continuity  |
|-------|------|-----------|----------|--------|-------------|
|       | Bank | Connector | Terminal |        |             |
| P2A00 | 1    | F102      | 57       | Ground | Not existed |
|       |      |           | 61       |        |             |
| P2A03 | 2    |           | 65       |        |             |
|       |      |           | 66       |        |             |

5. Also check harness for short to power.

Is the inspection result normal?

YES >> GO TO 10.

NO >> Repair open circuit, short to ground or short to power in harness or connectors.

## 10.CHECK A/F SENSOR 1 HEATER

Refer to [EC-197, "Component Inspection"](#).

Is the inspection result normal?

YES >> GO TO 11.

NO >> GO TO 13.

## 11.CHECK HEATED OXYGEN SENSOR 2

Refer to [EC-261, "Component Inspection"](#).

Is the inspection result normal?

YES >> GO TO 12.

NO >> Replace malfunctioning heated oxygen sensor 2. Refer to [EX-5, "VQ37VHR : Exploded View"](#).

## 12.CHECK INTERMITTENT INCIDENT

Perform [GI-44, "Intermittent Incident"](#).

Is the inspection result normal?

YES >> GO TO 13.

NO >> Repair or replace.

## 13.REPLACE AIR FUEL RATIO (A/F) SENSOR 1

Replace air fuel ratio (A/F) sensor 1.

**CAUTION:**

## P2A00, P2A03 A/F SENSOR 1

< DTC/CIRCUIT DIAGNOSIS >

[VQ37VHR FOR USA AND CANADA]

- Discard any A/F sensor which has been dropped from a height of more than 0.5 m (19.7 in) onto a hard surface such as a concrete floor; use a new one.
- Before installing new A/F sensor, clean exhaust system threads using Oxygen Sensor Thread Cleaner [commercial service tool (J-43897-18 or J-43897-12)] and approved Anti-seize Lubricant (commercial service tool).

Do you have CONSULT?

YES >> GO TO 14.

NO >> GO TO 15.

### 14. CONFIRM A/F ADJUSTMENT DATA

---

Ⓟ **With CONSULT**

1. Turn ignition switch ON.
2. Select "A/F ADJ-B1" and "A/F ADJ-B2" in "DATA MONITOR" mode with CONSULT.
3. Make sure that "0.000" is displayed on CONSULT screen.

Is "0.000" displayed?

YES >> INSPECTION END

NO >> GO TO 15.

### 15. CLEAR THE MIXTURE RATIO SELF-LEARNING VALUE

---

Clear the mixture ratio self-learning value. Refer to [EC-153. "Work Procedure"](#).

Do you have CONSULT?

YES >> GO TO 16.

NO >> INSPECTION END

### 16. CONFIRM A/F ADJUSTMENT DATA

---

Ⓟ **With CONSULT**

1. Turn ignition switch ON.
2. Select "A/F ADJ-B1" and "A/F ADJ-B2" in "DATA MONITOR" mode with CONSULT.
3. Make sure that "0.000" is displayed on CONSULT screen.

>> INSPECTION END

# ASCD BRAKE SWITCH

< DTC/CIRCUIT DIAGNOSIS >

[VQ37VHR FOR USA AND CANADA]

## ASCD BRAKE SWITCH

### Component Function Check

INFOID:000000006883151

#### 1. CHECK ASCD BRAKE SWITCH FUNCTION

##### With CONSULT

1. Turn ignition switch ON.
2. Select "BRAKE SW1" in "DATA MONITOR" mode with CONSULT.
3. Check "BRAKE SW1" indication under the following conditions.

| Monitor item | Condition   |                    | Indication |
|--------------|-------------|--------------------|------------|
| BRAKE SW1    | Brake pedal | Slightly depressed | OFF        |
|              | Brake pedal | Fully released     | ON         |

##### Without CONSULT

1. Turn ignition switch ON.
2. Check the voltage between ECM harness connector terminals as per the following.

| Connector | ECM                               |          | Condition   |                    | Voltage (V)     |
|-----------|-----------------------------------|----------|-------------|--------------------|-----------------|
|           | +                                 | -        |             |                    |                 |
|           | Terminal                          | Terminal |             |                    |                 |
| M107      | 126<br>(ASCD brake switch signal) | 128      | Brake pedal | Slightly depressed | Approx. 0       |
|           |                                   |          | Brake pedal | Fully released     | Battery voltage |

Is the inspection result normal?

YES >> INSPECTION END

NO >> Go to [EC-503. "Diagnosis Procedure"](#).

### Diagnosis Procedure

INFOID:000000006883152

#### 1. CHECK ASCD BRAKE SWITCH POWER SUPPLY CIRCUIT

1. Turn ignition switch OFF.
2. Disconnect ASCD brake switch harness connector.
3. Turn ignition switch ON.
4. Check the voltage between ASCD brake switch harness connector and ground.

| ASCD brake switch |          | Ground | Voltage         |
|-------------------|----------|--------|-----------------|
| Connector         | Terminal |        |                 |
| E109              | 1        | Ground | Battery voltage |

Is the inspection result normal?

YES >> GO TO 3.

NO >> GO TO 2.

#### 2. DETECT MALFUNCTIONING PART

Check the following.

- Fuse block (J/B) connector E103
- 10 A fuse (No. 3)
- Harness for open or short between ASCD brake switch and fuse

>> Repair open circuit or short to ground in harness or connectors.

#### 3. CHECK ASCD BRAKE SWITCH INPUT SIGNAL CIRCUIT FOR OPEN AND SHORT

1. Turn ignition switch OFF.
2. Disconnect ECM harness connector.
3. Check the continuity between ASCD brake switch harness connector and ECM harness connector.

# ASCD BRAKE SWITCH

< DTC/CIRCUIT DIAGNOSIS >

[VQ37VHR FOR USA AND CANADA]

| ASCD brake switch |          | ECM       |          | Continuity |
|-------------------|----------|-----------|----------|------------|
| Connector         | Terminal | Connector | Terminal |            |
| E109              | 2        | M107      | 126      | Existed    |

4. Also check harness for short to ground and short to power.

Is the inspection result normal?

- YES >> GO TO 5.
- NO >> GO TO 4.

## 4.DETECT MALFUNCTIONING PART

Check the following.

- Harness connectors E106, M6
- Harness for open or short between ECM and ASCD brake switch

>> Repair open circuit, short to ground or short to power in harness or connectors.

## 5.CHECK ASCD BRAKE SWITCH

Refer to [EC-504, "Component Inspection \(ASCD Brake Switch\)"](#)

Is the inspection result normal?

- YES >> GO TO 6.
- NO >> Replace ASCD brake switch. Refer to [BR-18, "Exploded View"](#).

## 6.CHECK INTERMITTENT INCIDENT

Refer to [GI-44, "Intermittent Incident"](#).

>> INSPECTION END

## Component Inspection (ASCD Brake Switch)

INFOID:000000006883153

### 1.CHECK ASCD BRAKE SWITCH-I

1. Turn ignition switch OFF.
2. Disconnect ASCD brake switch harness connector.
3. Check the continuity between ASCD brake switch terminals under the following conditions.

| Terminals | Condition   |                    | Continuity  |
|-----------|-------------|--------------------|-------------|
| 1 and 2   | Brake pedal | Fully released     | Existed     |
|           |             | Slightly depressed | Not existed |

Is the inspection result normal?

- YES >> INSPECTION END
- NO >> GO TO 2.

### 2.CHECK ASCD BRAKE SWITCH-II

1. Adjust ASCD brake switch installation. Refer to [BR-19, "Inspection and Adjustment"](#).
2. Check the continuity between ASCD brake switch terminals under the following conditions.

| Terminals | Condition   |                    | Continuity  |
|-----------|-------------|--------------------|-------------|
| 1 and 2   | Brake pedal | Fully released     | Existed     |
|           |             | Slightly depressed | Not existed |

Is the inspection result normal?

- YES >> INSPECTION END
- NO >> Replace ASCD brake switch. Refer to [BR-18, "Exploded View"](#).



# ASCD INDICATOR

< DTC/CIRCUIT DIAGNOSIS >

[VQ37VHR FOR USA AND CANADA]

## ASCD INDICATOR

### Component Function Check

INFOID:000000006883154

#### 1.CHECK ASCD INDICATOR FUNCTION

Check ASCD indicator under the following conditions.

| ASCD INDICATOR | CONDITION  |  | SPECIFICATION |
|----------------|--|--|---------------|
| CRUISE LAMP    | <ul style="list-style-type: none"><li>Ignition switch: ON</li></ul>  | <ul style="list-style-type: none"><li>MAIN switch: Pressed at the 1st time → at the 2nd time</li></ul> | ON → OFF      |
| SET LAMP       | <ul style="list-style-type: none"><li>MAIN switch: ON</li><li>When vehicle speed is between 40 km/h (25 MPH) and 144 km/h (89 MPH)</li></ul> | <ul style="list-style-type: none"><li>ASCD: Operating</li></ul>  | ON            |
|                |  | <ul style="list-style-type: none"><li>ASCD: Not operating</li></ul>                                    | OFF           |

Is the inspection result normal?

YES >> INSPECTION END

NO >> Go to [EC-505, "Diagnosis Procedure"](#).

### Diagnosis Procedure

INFOID:000000006883155

#### 1.CHECK DTC

Check that DTC UXXXX is not displayed.

Is the inspection result normal?

YES >> GO TO 2.

NO >> Perform trouble diagnosis for DTC UXXXX.

#### 2.CHECK DTC WITH "COMBINATION METER"

Refer to [MWI-31, "CONSULT Function"](#).

Is the inspection result normal?

YES >> GO TO 3.

NO >> Repair or replace.

#### 3.CHECK INTERMITTENT INCIDENT

Refer to [GI-44, "Intermittent Incident"](#).

Is the inspection result normal?

YES >> Replace combination meter. Refer to [MWI-79, "Exploded View"](#).

NO >> Repair or replace.

**COOLING FAN**

**Component Function Check**

INFOID:000000006883156

**1. CHECK COOLING FAN FUNCTION**

**With CONSULT**

1. Turn ignition switch ON.
2. Perform "FAN DUTY CONTROL" in "ACTIVE TEST" mode with CONSULT.
3. Make sure that cooling fan speed varies according to the percentage.

**Without CONSULT**

1. Perform IPDM E/R auto active test and check cooling fan motors operation, refer to [PCS-12. "Diagnosis Description"](#).
2. Make sure that cooling fan operates.

Is the inspection result normal?

- YES >> INSPECTION END  
 NO >> Go to [EC-506. "Diagnosis Procedure"](#).

**Diagnosis Procedure**

INFOID:000000006883157

**1. CHECK COOLING FAN CONTROL MODULE POWER SUPPLY CIRCUIT-I**

1. Turn ignition switch OFF.
2. Disconnect cooling fan control module harness connector.
3. Turn ignition switch ON.
4. Check the voltage between cooling fan control module harness connector and ground.

| Cooling fan control module |          | Ground | Voltage         |
|----------------------------|----------|--------|-----------------|
| Connector                  | Terminal |        |                 |
| E37                        | 3        | Ground | Battery voltage |

Is the inspection result normal?

- YES >> GO TO 2.  
 NO >> GO TO 7.

**2. CHECK COOLING FAN CONTROL MODULE GROUND CIRCUIT**

1. Turn ignition switch OFF.
2. Check the continuity between cooling fan control module harness connector and ground.

| Cooling fan control module |          | Ground | Continuity |
|----------------------------|----------|--------|------------|
| Connector                  | Terminal |        |            |
| E37                        | 1        | Ground | Existed    |

3. Also check harness for short to power.

Is the inspection result normal?

- YES >> GO TO 3.  
 NO >> Repair open circuit or short to power in harness or connectors.

**3. CHECK IPDM E/R GROUND CIRCUIT**

1. Disconnect IPDM E/R harness connectors.
2. Check the continuity between IPDM E/R harness connector and ground.

| IPDM E/R  |          | Ground | Continuity |
|-----------|----------|--------|------------|
| Connector | Terminal |        |            |
| E5        | 11       | Ground | Existed    |
| E6        | 41       |        |            |

3. Also check harness for short to power.

# COOLING FAN

[VQ37VHR FOR USA AND CANADA]

## < DTC/CIRCUIT DIAGNOSIS >

Is the inspection result normal?

YES >> GO TO 4.

NO >> Repair open circuit or short to power in harness or connectors.

### 4. CHECK COOLING FAN CONTROL SIGNAL CIRCUIT

1. Disconnect IPDM E/R harness connector.
2. Check the continuity between IPDM E/R harness connector and cooling fan control module harness connector.

| IPDM E/R  |          | Cooling fan control module |          | Continuity |
|-----------|----------|----------------------------|----------|------------|
| Connector | Terminal | Connector                  | Terminal |            |
| E9        | 97       | E37                        | 2        | Existed    |

3. Also check harness for short to ground and short to power.

Is the inspection result normal?

YES >> GO TO 5.

NO >> Repair open circuit, short to ground or short to power in harness or connectors.

### 5. CHECK COOLING FAN CONTROL MODULE OUTPUT SIGNAL CIRCUIT

1. Reconnect all harness connectors disconnected.
2. Disconnect cooling fan control module harness connectors.
3. Turn ignition switch ON.
4. Check the voltage between cooling fan control module harness connector and ground.

| Cooling fan control module |          | Ground | Voltage         |
|----------------------------|----------|--------|-----------------|
| Connector                  | Terminal |        |                 |
| E301                       | 4        | Ground | Battery voltage |
| E302                       | 6        |        |                 |

Is the inspection result normal?

YES >> GO TO 6.

NO >> Replace cooling fan control module. Refer to [CO-18, "Exploded View"](#).

### 6. CHECK COOLING FAN MOTORS -1 AND -2

Refer to [EC-508, "Component Inspection \(Cooling Fan Motor\)"](#).

Is the inspection result normal?

YES >> GO TO 11.

NO >> Replace cooling fan motor. Refer to [CO-18, "Exploded View"](#).

### 7. CHECK COOLING FAN CONTROL MODULE POWER SUPPLY CIRCUIT-II

1. Turn ignition switch OFF.
2. Disconnect cooling fan relay.
3. Turn ignition switch ON.
4. Check the voltage between cooling fan relay harness connector and ground.

| Cooling fan relay |          | Ground | Voltage         |
|-------------------|----------|--------|-----------------|
| Connector         | Terminal |        |                 |
| E17               | 1        | Ground | Battery voltage |
|                   | 3        |        |                 |

Is the inspection result normal?

YES >> GO TO 9.

NO >> GO TO 8.

### 8. DETECT MALFUNCTIONING PART

Check the following.

- 10A fuse (No. 42)

# COOLING FAN

[VQ37VHR FOR USA AND CANADA]

## < DTC/CIRCUIT DIAGNOSIS >

- IPDM E/R harness connector E7
- 50A fusible link (letter O)
- Harness for open or short between cooling fan relay and fuse
- Harness for open or short between cooling fan relay and battery

>> Repair open circuit, short to ground or short to power in harness or connectors.

### 9. CHECK COOLING FAN CONTROL MODULE POWER SUPPLY CIRCUIT-III

1. Turn ignition switch OFF.
2. Disconnect IPDM E/R harness connector.
3. Check the continuity between cooling fan relay harness connector and IPDM E/R harness connector.

| Cooling fan relay |          | IPDM E/R  |          | Continuity |
|-------------------|----------|-----------|----------|------------|
| Connector         | Terminal | Connector | Terminal |            |
| E17               | 2        | E7        | 73       | Existed    |

4. Check the continuity between cooling fan relay harness connector and cooling fan control module harness connector.

| Cooling fan relay |          | Cooling fan control module |          | Continuity |
|-------------------|----------|----------------------------|----------|------------|
| Connector         | Terminal | Connector                  | Terminal |            |
| E17               | 5        | E37                        | 3        | Existed    |

5. Also check harness for short to ground and short to power.

Is the inspection result normal?

YES >> GO TO 10.

NO >> Repair open circuit, short to ground or short to power in harness or connectors.

### 10. CHECK COOLING FAN RELAY

Refer to [EC-509, "Component Inspection \(Cooling Fan Relay\)"](#).

Is the inspection result normal?

YES >> GO TO 11.

NO >> Replace cooling fan relay.

### 11. CHECK INTERMITTENT INCIDENT

Perform [GI-44, "Intermittent Incident"](#).

Is the inspection result normal?

YES >> Replace IPDM E/R. Refer to [PCS-33, "Exploded View"](#).

NO >> Repair or replace harness connectors.

## Component Inspection (Cooling Fan Motor)

INFOID:000000006883158

### 1. CHECK COOLING FAN MOTOR

1. Turn ignition switch OFF.
2. Disconnect cooling fan control module harness connectors.
3. Supply cooling fan control module terminals with battery voltage and check operation.

| Cooling fan control module |           |          |     | Operation             |
|----------------------------|-----------|----------|-----|-----------------------|
| Motor                      | Connector | Terminal |     |                       |
|                            |           | (+)      | (-) |                       |
| 1                          | E301      | 4        | 5   | Cooling fan operates. |
| 2                          | E302      | 6        | 7   |                       |

Is the inspection result normal?

YES >> INSPECTION END

NO >> Replace cooling fan motor. Refer to [CO-18, "Exploded View"](#).

# COOLING FAN

< DTC/CIRCUIT DIAGNOSIS >

[VQ37VHR FOR USA AND CANADA]

## Component Inspection (Cooling Fan Relay)

INFOID:000000006883159

### 1. CHECK COOLING FAN RELAY

1. Turn ignition switch OFF.
2. Remove cooling fan relay.
3. Check the continuity between cooling fan relay terminals under the following conditions.

| Terminals | Conditions   | Continuity  |
|-----------|--|-------------|
| 3 and 5   | 12 V direct current supply between terminals 1 and 2 | Existed     |
|           | No current supply                                    | Not existed |

Is the inspection result normal?

- YES >> INSPECTION END  
NO >> Replace cooling fan relay.

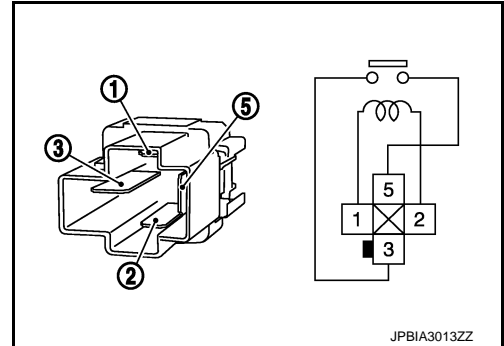

A

EC

C

D

E

F

G

H

I

J

K

L

M

N

O

P

# ELECTRICAL LOAD SIGNAL

< DTC/CIRCUIT DIAGNOSIS >

[VQ37VHR FOR USA AND CANADA]

## ELECTRICAL LOAD SIGNAL

### Description

INFOID:000000006883160

The electrical load signal (Headlamp switch signal, rear window defogger switch signal, etc.) is transferred via the CAN communication line.

### Component Function Check

INFOID:000000006883161

#### 1. CHECK REAR WINDOW DEFOGGER SWITCH FUNCTION

1. Turn ignition switch ON.
2. Connect CONSULT and select "DATA MONITOR" mode.
3. Select "LOAD SIGNAL" and check indication under the following conditions.

| Monitor item | Condition                   | Indication |     |
|--------------|-----------------------------|------------|-----|
| LOAD SIGNAL  | Rear window defogger switch | ON         | ON  |
|              |                             | OFF        | OFF |

Is the inspection result normal?

YES >> GO TO 2.

NO >> Go to [EC-510, "Diagnosis Procedure"](#).

#### 2. CHECK LIGHTING SWITCH FUNCTION

Check "LOAD SIGNAL" indication under the following conditions.

| Monitor item | Condition       | Indication         |     |
|--------------|-----------------|--------------------|-----|
| LOAD SIGNAL  | Lighting switch | ON at 2nd position | ON  |
|              |                 | OFF                | OFF |

Is the inspection result normal?

YES >> GO TO 3.

NO >> Go to [EC-510, "Diagnosis Procedure"](#).

#### 3. CHECK HEATER FAN CONTROL SWITCH FUNCTION

Select "HEATER FAN SW" and check indication under the following conditions.

| Monitor item  | Condition                 | Indication |     |
|---------------|---------------------------|------------|-----|
| HEATER FAN SW | Heater fan control switch | ON         | ON  |
|               |                           | OFF        | OFF |

Is the inspection result normal?

YES >> INSPECTION END

NO >> Go to [EC-510, "Diagnosis Procedure"](#).

### Diagnosis Procedure

INFOID:000000006883162

#### 1. INSPECTION START

Confirm the malfunctioning circuit (rear window defogger, headlamp or heater fan). Refer to [EC-510, "Component Function Check"](#).

Which circuit is related to the incident?

Rear window defogger >> GO TO 2.

Headlamp >> GO TO 3.

Heater fan >> GO TO 4.

#### 2. CHECK REAR WINDOW DEFOGGER SYSTEM

Refer to [DEF-11, "Work Flow"](#).

# ELECTRICAL LOAD SIGNAL

< DTC/CIRCUIT DIAGNOSIS >

[VQ37VHR FOR USA AND CANADA]

>> INSPECTION END

## 3.CHECK HEADLAMP SYSTEM

Refer to [EXL-49, "Work Flow"](#).

>> INSPECTION END

## 4.CHECK HEATER FAN CONTROL SYSTEM

Refer to [HAC-68, "Work Flow"](#).

>> INSPECTION END

A

EC

C

D

E

F

G

H

I

J

K

L

M

N

O

P

## FUEL INJECTOR

### Component Function Check

INFOID:000000006883163

#### 1.INSPECTION START

Turn ignition switch to START.

Are any cylinders ignited?

- YES >> GO TO 2.
- NO >> Go to [EC-512, "Diagnosis Procedure"](#).

#### 2.CHECK FUEL INJECTOR FUNCTION

##### Ⓜ With CONSULT

1. Start engine.
2. Perform "POWER BALANCE" in "ACTIVE TEST" mode with CONSULT.
3. Make sure that each circuit produces a momentary engine speed drop.

##### ⓧ Without CONSULT

1. Start engine.
2. Listen to each fuel injector operating sound.

**Clicking sound should be heard.**

Is the inspection result normal?

- YES >> INSPECTION END
- NO >> Go to [EC-512, "Diagnosis Procedure"](#).

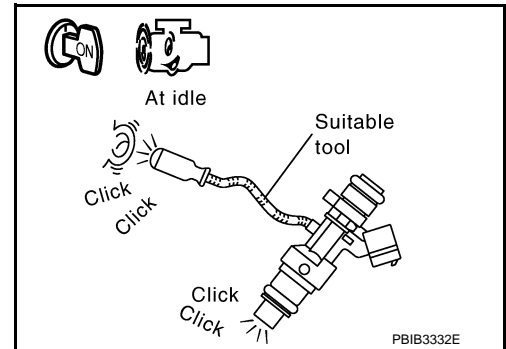

### Diagnosis Procedure

INFOID:000000006883164

#### 1.CHECK FUEL INJECTOR POWER SUPPLY CIRCUIT

1. Turn ignition switch OFF.
2. Disconnect fuel injector harness connector.
3. Turn ignition switch ON.
4. Check the voltage between fuel injector harness connector and ground.

| Fuel injector |           |          | Ground | Voltage         |
|---------------|-----------|----------|--------|-----------------|
| Cylinder      | Connector | Terminal |        |                 |
| 1             | F121      | 1        | Ground | Battery voltage |
| 2             | F122      | 1        |        |                 |
| 3             | F123      | 1        |        |                 |
| 4             | F124      | 1        |        |                 |
| 5             | F125      | 1        |        |                 |
| 6             | F126      | 1        |        |                 |

Is the inspection result normal?

- YES >> GO TO 3.
- NO >> GO TO 2.

#### 2.DETECT MALFUNCTIONING PART

Check the following.

- Harness connectors E20, F40
- Harness connectors F30, F120
- IPDM E/R harness connector E7
- 10 A fuse (No. 44)



# FUEL INJECTOR

[VQ37VHR FOR USA AND CANADA]

## < DTC/CIRCUIT DIAGNOSIS >

- Harness for open or short between fuel injector and fuse

>> Repair open circuit, short to ground or short to power in harness or connectors.

### 3.CHECK FUEL INJECTOR OUTPUT SIGNAL CIRCUIT FOR OPEN AND SHORT

1. Turn ignition switch OFF.
2. Disconnect ECM harness connector.
3. Check the continuity between fuel injector harness connector and ECM harness connector.

| Fuel injector |           |          | ECM       |          | Continuity |
|---------------|-----------|----------|-----------|----------|------------|
| Cylinder      | Connector | Terminal | Connector | Terminal |            |
| 1             | F121      | 2        | F102      | 89       | Existed    |
| 2             | F122      | 2        |           | 85       |            |
| 3             | F123      | 2        |           | 81       |            |
| 4             | F124      | 2        |           | 90       |            |
| 5             | F125      | 2        |           | 86       |            |
| 6             | F126      | 2        |           | 82       |            |

4. Also check harness for short to ground and short to power.

Is the inspection result normal?

- YES >> GO TO 5.
- NO >> GO TO 4

### 4.DETECT MALFUNCTIONING PART

Check the following.

- Harness connectors F30, F120
- Harness for open or short between fuel injector and ECM

>> Repair open circuit, short to ground or short to power in harness or connectors.

### 5.CHECK FUEL INJECTOR

Refer to [EC-513. "Component Inspection"](#).

Is the inspection result normal?

- YES >> GO TO 6.
- NO >> Replace malfunctioning fuel injector. Refer to [EM-39. "Exploded View"](#).

### 6.CHECK INTERMITTENT INCIDENT

Refer to [GI-44. "Intermittent Incident"](#).

Is the inspection result normal?

- YES >> Replace IPDM E/R. Refer to [PCS-33. "Exploded View"](#).
- NO >> Repair open circuit, short to ground or short to power in harness or connectors.

## Component Inspection

INFOID:000000006883165

### 1.CHECK FUEL INJECTOR

1. Turn ignition switch OFF.
2. Disconnect fuel injector harness connector.
3. Check resistance between fuel injector terminals as follows.

| Terminals | Resistance ( $\Omega$ )                 |
|-----------|---|
| 1 and 2   | 11.1 - 14.3 [at 10 - 60°C (60 - 140°F)] |

Is the inspection result normal?

- YES >> INSPECTION END
- NO >> Replace malfunctioning fuel injector. Refer to [EM-39. "Exploded View"](#).

# FUEL PUMP

< DTC/CIRCUIT DIAGNOSIS >

[VQ37VHR FOR USA AND CANADA]

## FUEL PUMP

### Component Function Check

INFOID:000000006883166

#### 1.CHECK FUEL PUMP FUNCTION

1. Turn ignition switch ON.
2. Pinch fuel feed hose (1) with two fingers.

**Fuel pressure pulsation should be felt on the fuel feed hose for 1 second after ignition switch is turned ON.**

Is the inspection result normal?

- YES >> INSPECTION END  
NO >> [EC-514. "Diagnosis Procedure"](#).

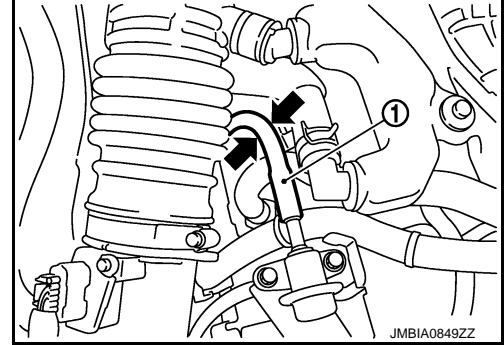

### Diagnosis Procedure

INFOID:000000006883167

#### 1.CHECK FUEL PUMP POWER SUPPLY CIRCUIT-I

1. Turn ignition switch OFF.
2. Disconnect ECM harness connector.
3. Turn ignition switch ON.
4. Check the voltage between ECM harness connector and ground.

| ECM       |          | Ground | Voltage         |
|-----------|----------|--------|-----------------|
| Connector | Terminal |        |                 |
| F101      | 22       | Ground | Battery voltage |

Is the inspection result normal?

- YES >> GO TO 4.  
NO >> GO TO 2.

#### 2.CHECK FUEL PUMP POWER SUPPLY CIRCUIT-II

Check the voltage between IPDM E/R harness connector and ground.

| IPDM E/R  |          | Ground | Voltage         |
|-----------|----------|--------|-----------------|
| Connector | Terminal |        |                 |
| E7        | 77       | Ground | Battery voltage |

Is the inspection result normal?

- YES >> GO TO 3.  
NO >> GO TO 10.

#### 3.DETECT MALFUNCTIONING PART

Check the following.

- Harness connectors E20, F40
- Harness for open or short between IPDM E/R and ECM

>> Repair open circuit, short to ground or short to power in harness or connectors.

#### 4.CHECK FUEL PUMP POWER SUPPLY CIRCUIT-III

1. Turn ignition switch OFF.
2. Reconnect all harness connectors disconnected.
3. Disconnect "fuel level sensor unit and fuel pump" harness connector.
4. Turn ignition switch ON.

# FUEL PUMP

< DTC/CIRCUIT DIAGNOSIS >

[VQ37VHR FOR USA AND CANADA]

5. Check the voltage between “fuel level sensor unit and fuel pump” harness connector and ground.

| Fuel level sensor unit and fuel pump |          | Ground | Voltage   |
|--------------------------------------|----------|--------|---|
| Connector                            | Terminal |        |   |
| B241                                 | 1        | Ground | Battery voltage should exist for 1 second after ignition switch is turned ON. |

Is the inspection result normal?

YES >> GO TO 8.

NO >> GO TO 5.

## 5.CHECK 15A FUSE

1. Turn ignition switch OFF.
2. Disconnect 15A fuse (No. 41) from IPDM E/R.
3. Check 15 A fuse.

Is the inspection result normal?

YES >> GO TO 6.

NO >> Replace fuse.

## 6.CHECK FUEL PUMP POWER SUPPLY CIRCUIT-IV

1. Disconnect IPDM E/R harness connector.
2. Check the continuity between IPDM E/R harness connector and “fuel level sensor unit and fuel pump” harness connector.

| IPDM E/R  |          | Fuel level sensor unit and fuel pump |          | Continuity |
|-----------|----------|--------------------------------------|----------|------------|
| Connector | Terminal | Connector                            | Terminal |            |
| E5        | 13       | B241                                 | 1        | Existed    |

3. Also check harness for short to ground and short to power.

Is the inspection result normal?

YES >> GO TO 10.

NO >> GO TO 7.

## 7.DETECT MALFUNCTIONING PART

Check the following.

- Harness connectors E105, B3
- Harness connectors B51, B230
- IPDM E/R harness connector E5
- Harness for open or short between IPDM E/R and “fuel level sensor unit and fuel pump”

>> Repair open circuit, short to ground or short to power in harness or connectors.

## 8.CHECK FUEL PUMP GROUND CIRCUIT

1. Turn ignition switch OFF.
2. Check the continuity between “fuel level sensor unit and fuel pump” harness connector and ground.

| Fuel level sensor unit and fuel pump |          | Ground | Continuity |
|--------------------------------------|----------|--------|------------|
| Connector                            | Terminal |        |            |
| B241                                 | 3        | Ground | Existed    |

3. Also check harness for short to power.

Is the inspection result normal?

YES >> GO TO 9.

NO >> Repair open circuit or short to power in harness or connectors.

## 9.CHECK FUEL PUMP

# FUEL PUMP

[VQ37VHR FOR USA AND CANADA]

< DTC/CIRCUIT DIAGNOSIS >

Refer to [EC-516. "Component Inspection"](#).

Is the inspection result normal?

YES >> GO TO 10.

NO >> Replace fuel pump. Refer to [FL-5. "Exploded View"](#).

## 10.CHECK INTERMITTENT INCIDENT

Refer to [GI-44. "Intermittent Incident"](#).

Is the inspection result normal?

YES >> Replace IPDM E/R. Refer to [PCS-33. "Exploded View"](#).

NO >> Repair or replace harness or connectors.

## Component Inspection

INFOID:000000006883168

### 1.CHECK FUEL PUMP

1. Turn ignition switch OFF.
2. Disconnect "fuel level sensor unit and fuel pump" harness connector.
3. Check resistance between "fuel level sensor unit and fuel pump" terminals as follows.

| Terminals | Resistance ( $\Omega$ )    |
|-----------|----------------------------|
| 1 and 3   | 0.2 - 5.0 [at 25°C (77°F)] |

Is the inspection result normal?

YES >> INSPECTION END

NO >> Replace "fuel level sensor unit and fuel pump". Refer to [FL-5. "Exploded View"](#).

# ICC BRAKE SWITCH

< DTC/CIRCUIT DIAGNOSIS >

[VQ37VHR FOR USA AND CANADA]

## ICC BRAKE SWITCH

### Component Function Check

INFOID:000000006883169

#### 1. CHECK ICC BRAKE SWITCH FUNCTION

##### With CONSULT

1. Turn ignition switch ON.
2. Select "BRAKE SW1" in "DATA MONITOR" mode with CONSULT.
3. Check "BRAKE SW1" indication under the following conditions.

| Monitor item | Condition   |                    | Indication |
|--------------|-------------|--------------------|------------|
| BRAKE SW1    | Brake pedal | Slightly depressed | OFF        |
|              | Brake pedal | Fully released     | ON         |

##### Without CONSULT

1. Turn ignition switch ON.
2. Check the voltage between ECM harness connector terminals as per the following.

| ECM       |                                  |          | Condition   | Voltage (V)        |                 |
|-----------|----------------------------------|----------|-------------|--------------------|-----------------|
| Connector | +                                | -        |             |                    |                 |
|           | Terminal                         | Terminal |             |                    |                 |
| M107      | 126<br>(ICC brake switch signal) | 128      | Brake pedal | Slightly depressed | Approx. 0       |
|           |                                  |          |             | Fully released     | Battery voltage |

Is the inspection result normal?

- YES >> INSPECTION END  
NO >> Go to [EC-517. "Diagnosis Procedure"](#).

### Diagnosis Procedure

INFOID:000000006883170

#### 1. CHECK ICC BRAKE SWITCH POWER SUPPLY CIRCUIT

1. Turn ignition switch OFF.
2. Disconnect ICC brake switch harness connector.
3. Turn ignition switch ON.
4. Check the voltage between ICC brake switch harness connector and ground.

| ICC brake switch |          | Ground | Voltage         |
|------------------|----------|--------|-----------------|
| Connector        | Terminal |        |                 |
| E114             | 1        | Ground | Battery voltage |

Is the inspection result normal?

- YES >> GO TO 3.  
NO >> GO TO 2.

#### 2. DETECT MALFUNCTIONING PART

Check the following.

- Fuse block (J/B) connector E103
- 10A fuse (No. 3)
- Harness for open or short between ICC brake switch and fuse

>> Repair open circuit or short to ground in harness or connectors.

#### 3. CHECK ICC BRAKE SWITCH INPUT SIGNAL CIRCUIT FOR OPEN AND SHORT

1. Turn ignition switch OFF.
2. Disconnect ECM harness connector.

# ICC BRAKE SWITCH

[VQ37VHR FOR USA AND CANADA]

## < DTC/CIRCUIT DIAGNOSIS >

3. Check the continuity between ICC brake switch harness connector and ECM harness connector.

| ICC brake switch |          | ECM       |          | Continuity |
|------------------|----------|-----------|----------|------------|
| Connector        | Terminal | Connector | Terminal |            |
| E114             | 2        | M107      | 126      | Existed    |

4. Also check harness for short to ground and short to power.

### Is the inspection result normal?

YES >> GO TO 5.

NO >> GO TO 4.

## 4.DETECT MALFUNCTIONING PART

Check the following.

- Harness connectors E106, M6
- Harness for open or short between ICC brake switch and ECM

>> Repair open circuit, short to ground or short to power in harness or connectors.

## 5.CHECK ICC BRAKE SWITCH

Refer to [EC-518, "Component Inspection \(ICC Brake Switch\)"](#).

### Is the inspection result normal?

YES >> GO TO 6.

NO >> Replace ICC brake switch. Refer to [BR-18, "Exploded View"](#).

## 6.CHECK INTERMITTENT INCIDENT

Refer to [GI-44, "Intermittent Incident"](#).

>> INSPECTION END

## Component Inspection (ICC Brake Switch)

INFOID:000000006883171

### 1.CHECK ICC BRAKE SWITCH-I

1. Turn ignition switch OFF.
2. Disconnect ICC brake switch harness connector.
3. Check the continuity between ICC brake switch terminals under the following conditions.

| Terminals | Condition   |                    | Continuity  |
|-----------|-------------|--------------------|-------------|
| 1 and 2   | Brake pedal | Fully released     | Existed     |
|           |             | Slightly depressed | Not existed |

### Is the inspection result normal?

YES >> INSPECTION END

NO >> GO TO 2.

### 2.CHECK ICC BRAKE SWITCH-II

1. Adjust ICC brake switch installation. Refer to [BR-19, "Inspection and Adjustment"](#).
2. Check the continuity between ICC brake switch terminals under the following conditions.

| Terminals | Condition   |                    | Continuity  |
|-----------|-------------|--------------------|-------------|
| 1 and 2   | Brake pedal | Fully released     | Existed     |
|           |             | Slightly depressed | Not existed |

### Is the inspection result normal?

YES >> INSPECTION END

NO >> Replace ICC brake switch. Refer to [BR-18, "Exploded View"](#).

# IGNITION SIGNAL

< DTC/CIRCUIT DIAGNOSIS >

[VQ37VHR FOR USA AND CANADA]

## IGNITION SIGNAL

### Component Function Check

INFOID:000000006883172

#### 1.INSPECTION START

Turn ignition switch OFF, and restart engine.

Does the engine start?

YES-1 >> With CONSULT: GO TO 2.

YES-2 >> Without CONSULT: GO TO 3.

No >> Go to [EC-519, "Diagnosis Procedure"](#).

#### 2.CHECK IGNITION SIGNAL FUNCTION

##### With CONSULT

1. Perform "POWER BALANCE" in "ACTIVE TEST" mode with CONSULT.

2. Make sure that each circuit produces a momentary engine speed drop.

Is the inspection result normal?

YES >> INSPECTION END

NO >> Go to [EC-519, "Diagnosis Procedure"](#).

#### 3.CHECK IGNITION SIGNAL FUNCTION

##### Without CONSULT

1. Let engine idle.

2. Read the voltage signal between ECM harness connector terminals under the following conditions with an oscilloscope.

| ECM       |          |           |          | Voltage signal |
|-----------|----------|-----------|----------|----------------|
| +         |          | -         |          |                |
| Connector | Terminal | Connector | Terminal |                |
| F101      | 11       | M107      | 128      |                |
|           | 12       |           |          |                |
|           | 15       |           |          |                |
|           | 16       |           |          |                |
|           | 19       |           |          |                |
|           | 20       |           |          |                |

##### NOTE:

The pulse cycle changes depending on rpm at idle.

Is the inspection result normal?

YES >> INSPECTION END

NO >> Go to [EC-519, "Diagnosis Procedure"](#).

### Diagnosis Procedure

INFOID:000000006883173

#### 1.CHECK IGNITION COIL POWER SUPPLY CIRCUIT-I

1. Turn ignition switch OFF, wait at least 10 seconds and then turn it ON.

2. Check the voltage between ECM harness connector terminals as per the following.

| ECM       |          |          | Voltage         |
|-----------|----------|----------|-----------------|
| Connector | +        | -        |                 |
|           | Terminal | Terminal |                 |
| M107      | 125      | 128      | Battery voltage |

Is the inspection result normal?

YES >> GO TO 2.

# IGNITION SIGNAL

< DTC/CIRCUIT DIAGNOSIS >

[VQ37VHR FOR USA AND CANADA]

NO >> Go to [EC-180, "Diagnosis Procedure"](#).

## 2.CHECK IGNITION COIL POWER SUPPLY CIRCUIT-II

1. Turn ignition switch OFF.
2. Disconnect condenser harness connector.
3. Turn ignition switch ON.
4. Check the voltage between condenser harness connector and ground.

| Condenser |          | Ground | Voltage         |
|-----------|----------|--------|-----------------|
| Connector | Terminal |        |                 |
| F8        | 1        | Ground | Battery voltage |

Is the inspection result normal?

YES >> GO TO 5.

NO >> GO TO 3.

## 3.CHECK IGNITION COIL POWER SUPPLY CIRCUIT-III

1. Turn ignition switch OFF.
2. Disconnect IPDM E/R harness connector.
3. Check the continuity between IPDM E/R harness connector and condenser harness connector.

| IPDM E/R  |          | Condenser |          | Continuity |
|-----------|----------|-----------|----------|------------|
| Connector | Terminal | Connector | Terminal |            |
| E5        | 5        | F8        | 1        | Existed    |

4. Also check harness for short to ground and short to power.

Is the inspection result normal?

YES >> Go to [EC-180, "Diagnosis Procedure"](#).

NO >> GO TO 4.

## 4.DETECT MALFUNCTIONING PART

Check the following.

- Harness connectors E20, F40
- Harness for open or short between IPDM E/R and condenser

>> Repair open circuit, short to ground or short to power in harness or connectors.

## 5.CHECK CONDENSER GROUND CIRCUIT FOR OPEN AND SHORT

1. Turn ignition switch OFF.
2. Check the continuity between condenser harness connector and ground.

| Condenser |          | Ground | Continuity |
|-----------|----------|--------|------------|
| Connector | Terminal |        |            |
| F8        | 2        | Ground | Existed    |

3. Also check harness for short to power.

Is the inspection result normal?

YES >> GO TO 6.

NO >> Repair open circuit or short to power in harness or connectors.

## 6.CHECK CONDENSER

Refer to [EC-523, "Component Inspection \(Condenser\)"](#)

Is the inspection result normal?

YES >> GO TO 7.

NO >> Replace condenser.

## 7.CHECK IGNITION COIL POWER SUPPLY CIRCUIT-IV



# IGNITION SIGNAL

< DTC/CIRCUIT DIAGNOSIS >

[VQ37VHR FOR USA AND CANADA]

1. Reconnect all harness connectors disconnected.
2. Disconnect ignition coil harness connector.
3. Turn ignition switch ON.
4. Check the voltage between ignition coil harness connector and ground.

| Ignition coil |           |          | Ground | Voltage         |
|---------------|-----------|----------|--------|-----------------|
| Cylinder      | Connector | Terminal |        |                 |
| 1             | F11       | 3        | Ground | Battery voltage |
| 2             | F12       | 3        |        |                 |
| 3             | F13       | 3        |        |                 |
| 4             | F14       | 3        |        |                 |
| 5             | F15       | 3        |        |                 |
| 6             | F16       | 3        |        |                 |

Is the inspection result normal?

YES >> GO TO 9.

NO >> GO TO 8.

## 8.DETECT MALFUNCTIONING PART

Check the following.

- Harness connector F40, E20
- Harness for open or short between ignition coil and harness connector F40

>> Repair or replace harness or connectors.

## 9.CHECK IGNITION COIL GROUND CIRCUIT FOR OPEN AND SHORT

1. Turn ignition switch OFF.
2. Check the continuity between ignition coil harness connector and ground.

| Ignition coil |           |          | Ground | Continuity |
|---------------|-----------|----------|--------|------------|
| Cylinder      | Connector | Terminal |        |            |
| 1             | F11       | 2        | Ground | Existed    |
| 2             | F12       | 2        |        |            |
| 3             | F13       | 2        |        |            |
| 4             | F14       | 2        |        |            |
| 5             | F15       | 2        |        |            |
| 6             | F16       | 2        |        |            |

3. Also check harness for short to power.

Is the inspection result normal?

YES >> GO TO 10.

NO >> Repair open circuit or short to power in harness or connectors.

## 10.CHECK IGNITION COIL OUTPUT SIGNAL CIRCUIT FOR OPEN AND SHORT

1. Disconnect ECM harness connector.
2. Check the continuity between ignition coil harness connector and ECM harness connector.

# IGNITION SIGNAL

< DTC/CIRCUIT DIAGNOSIS >

[VQ37VHR FOR USA AND CANADA]

| Ignition coil |           |          | ECM       |          | Continuity |
|---------------|-----------|----------|-----------|----------|------------|
| Cylinder      | Connector | Terminal | Connector | Terminal |            |
| 1             | F11       | 1        | F101      | 20       | Existed    |
| 2             | F12       | 1        |           | 16       |            |
| 3             | F13       | 1        |           | 12       |            |
| 4             | F14       | 1        |           | 11       |            |
| 5             | F15       | 1        |           | 15       |            |
| 6             | F16       | 1        |           | 19       |            |

3. Also check harness for short to ground and short to power.

Is the inspection result normal?

YES >> GO TO 11.

NO >> Repair open circuit, short to ground or short to power in harness or connectors.

## 11.CHECK IGNITION COIL WITH POWER TRANSISTOR

Refer to [EC-522, "Component Inspection \(Ignition Coil with Power Transistor\)"](#).

Is the inspection result normal?

YES >> GO TO 12.

NO >> Replace malfunctioning ignition coil with power transistor. Refer to [EM-39, "Exploded View"](#).

## 12.CHECK INTERMITTENT INCIDENT

Refer to [GI-44, "Intermittent Incident"](#).

>> INSPECTION END

## Component Inspection (Ignition Coil with Power Transistor)

INFOID:000000006883174

### 1.CHECK IGNITION COIL WITH POWER TRANSISTOR-I

1. Turn ignition switch OFF.
2. Disconnect ignition coil harness connector.
3. Check resistance between ignition coil terminals as per the following.

| Terminals | Resistance ( $\Omega$ ) [at 25°C (77°F)] |
|-----------|--|
| 1 and 2   | Except 0 or $\infty$                     |
| 1 and 3   | Except 0                                 |
| 2 and 3   |  |

Is the inspection result normal?

YES >> GO TO 2.

NO >> Replace malfunctioning ignition coil with power transistor. Refer to [EM-39, "Exploded View"](#).

### 2.CHECK IGNITION COIL WITH POWER TRANSISTOR-II

#### **CAUTION:**

**Perform the following procedure in a place where with no combustible objects and good ventilation.**

1. Turn ignition switch OFF.
2. Reconnect all harness connectors disconnected.

# IGNITION SIGNAL

[VQ37VHR FOR USA AND CANADA]

## < DTC/CIRCUIT DIAGNOSIS >

3. Remove fuel pump fuse (1) in IPDM E/R (2) to release fuel pressure.  
**NOTE:**  
 Do not use CONSULT to release fuel pressure, or fuel pressure applies again during the following procedure.
4. Start engine.
5. After engine stalls, crank it two or three times to release all fuel pressure.
6. Turn ignition switch OFF.
7. Remove all ignition coil harness connectors to avoid the electrical discharge from the ignition coils.
8. Remove ignition coil and spark plug of the cylinder to be checked.
9. Crank engine for 5 seconds or more to remove combustion gas in the cylinder.
10. Connect spark plug and harness connector to ignition coil.
11. Fix ignition coil using a rope etc. with gap of 13 - 17 mm (0.52 - 0.66 in) between the edge of the spark plug and grounded metal portion as shown in the figure.
12. Crank engine for about three seconds, and check whether spark is generated between the spark plug and the grounded metal portion.

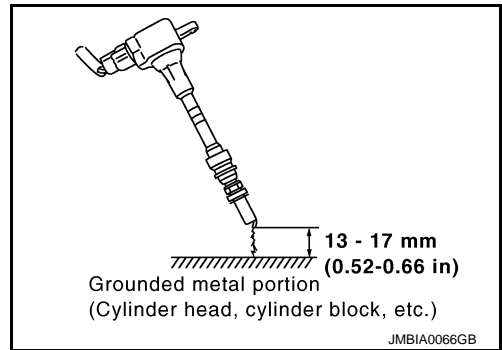
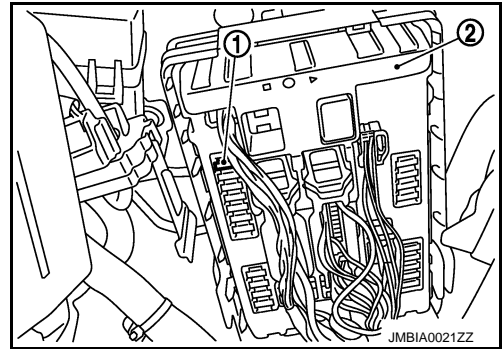

**Spark should be generated.**

### CAUTION:

- Never place the spark plug and the ignition coil within 50 cm (19.7 in) each other. Be careful not to get an electrical shock while checking, because the electrical discharge voltage becomes 20 kV or more.
- It might damage the ignition coil if the gap of more than 17 mm (0.66 in) is made.

### NOTE:

When the gap is less than 13 mm (0.52 in), spark might be generated even if the coil is malfunctioning.

### Is the inspection result normal?

YES >> INSPECTION END

NO >> Replace malfunctioning ignition coil with power transistor. Refer to [EM-39, "Exploded View"](#).

## Component Inspection (Condenser)

INFOID:000000006883175

### 1. CHECK CONDENSER

1. Turn ignition switch OFF.
2. Disconnect condenser harness connector.
3. Check resistance between condenser terminals as per the following.

| Terminals | Resistance (MΩ)          |
|-----------|--------------------------|
| 1 and 2   | Above 1 [at 25°C (77°F)] |

### Is the inspection result normal?

YES >> INSPECTION END

NO >> Replace condenser.

# MALFUNCTION INDICATOR LAMP

< DTC/CIRCUIT DIAGNOSIS >

[VQ37VHR FOR USA AND CANADA]

## MALFUNCTION INDICATOR LAMP

### Component Function Check

INFOID:000000006883176

#### 1.CHECK MIL FUNCTION

---

1. Turn ignition switch ON.
2. Make sure that MIL illuminates.

Is the inspection result normal?

- YES >> INSPECTION END
- NO >> Go to [EC-524, "Diagnosis Procedure"](#).

### Diagnosis Procedure

INFOID:000000006883177

#### 1.CHECK DTC

---

Check that DTC UXXXX is not displayed.

Is the inspection result normal?

- YES >> GO TO 2.
- NO >> Perform trouble diagnosis for DTC UXXXX.

#### 2.CHECK DTC WITH "COMBINATION METER"

---

Refer to [MWI-31, "CONSULT Function"](#).

Is the inspection result normal?

- YES >> GO TO 3.
- NO >> Repair or replace.

#### 3.CHECK INTERMITTENT INCIDENT

---

Refer to [GI-44, "Intermittent Incident"](#).

Is the inspection result normal?

- YES >> Replace combination meter. Refer to [MWI-79, "Exploded View"](#).
- NO >> Repair or replace.

# ON BOARD REFUELING VAPOR RECOVERY (ORVR)

< DTC/CIRCUIT DIAGNOSIS >

[VQ37VHR FOR USA AND CANADA]

## ON BOARD REFUELING VAPOR RECOVERY (ORVR)

### Component Function Check

INFOID:000000006883178

#### 1.CHECK ORVR FUNCTION

Check whether the following symptoms are present.

- Fuel odor from EVAP canister is strong.
- Cannot refuel/Fuel odor from the fuel filler opening is strong while refueling.

Are any symptoms present?

- YES >> Go to [EC-525. "Diagnosis Procedure"](#).  
NO >> INSPECTION END

#### Diagnosis Procedure

INFOID:000000006883179

#### 1.INSPECTION START

Check whether the following symptoms are present.

- A: Fuel odor from EVAP canister is strong.  
B: Cannot refuel/Fuel odor from the fuel filler opening is strong while refueling.

Which symptom is present?

- A >> GO TO 2.  
B >> GO TO 7.

#### 2.CHECK EVAP CANISTER

1. Remove EVAP canister with EVAP canister vent control valve and EVAP control system pressure sensor attached.
2. Weigh the EVAP canister with EVAP canister vent control valve and EVAP control system pressure sensor attached.

**The weight should be less than 2.1 kg (4.6 lb).**

Is the inspection result normal?

- YES >> GO TO 3.  
NO >> GO TO 4.

#### 3.CHECK IF EVAP CANISTER IS SATURATED WITH WATER

Check if water will drain from EVAP canister (1).

- 2: EVAP canister vent control valve

Does water drain from the EVAP canister?

- YES >> GO TO 4.  
NO >> GO TO 6.

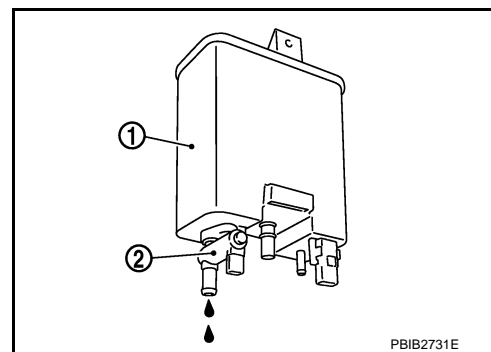

#### 4.REPLACE EVAP CANISTER

Replace EVAP canister with a new one.

>> GO TO 5.

#### 5.DETECT MALFUNCTIONING PART

Check the EVAP hose between EVAP canister and vehicle frame for clogging or poor connection.

>> Repair or replace EVAP hose.

#### 6.CHECK REFUELING EVAP VAPOR CUT VALVE

Refer to [EC-527. "Component Inspection"](#).

# ON BOARD REFUELING VAPOR RECOVERY (ORVR)

[VQ37VHR FOR USA AND CANADA]

< DTC/CIRCUIT DIAGNOSIS >

Is the inspection result normal?

YES >> INSPECTION END

NO >> Replace refueling EVAP vapor cut valve with fuel tank. Refer to [FL-10. "Exploded View"](#).

## 7. CHECK EVAP CANISTER

1. Remove EVAP canister with EVAP canister vent control valve and EVAP control system pressure sensor attached.

2. Weigh the EVAP canister with EVAP canister vent control valve and EVAP control system pressure sensor attached.

**The weight should be less than 2.1 kg (4.6 lb).**

Is the inspection result normal?

YES >> GO TO 8.

NO >> GO TO 9.

## 8. CHECK IF EVAP CANISTER IS SATURATED WITH WATER

Check if water will drain from EVAP canister (1).

2 : EVAP canister vent control valve

Does water drain from the EVAP canister?

YES >> GO TO 9.

NO >> GO TO 11.

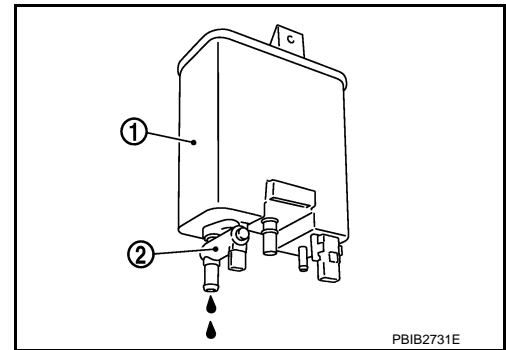

## 9. REPLACE EVAP CANISTER

Replace EVAP canister with a new one.

>> GO TO 10.

## 10. DETECT MALFUNCTIONING PART

Check the EVAP hose between EVAP canister and vehicle frame for clogging or poor connection.

>> Repair or replace EVAP hose.

## 11. CHECK VENT HOSES AND VENT TUBES

Check hoses and tubes between EVAP canister and refueling control valve for clogging, kinks, looseness and improper connection.

Is the inspection result normal?

YES >> GO TO 12.

NO >> Repair or replace hoses and tubes.

## 12. CHECK FILLER NECK TUBE

Check recirculation line for clogging, dents and cracks.

Is the inspection result normal?

YES >> GO TO 13.

NO >> Replace filler neck tube.

## 13. CHECK REFUELING EVAP VAPOR CUT VALVE

Refer to [EC-527. "Component Inspection"](#).

Is the inspection result normal?

YES >> GO TO 14.

NO >> Replace refueling EVAP vapor cut valve with fuel tank. Refer to [FL-10. "Exploded View"](#).

## 14. CHECK FUEL FILLER TUBE

Check filler neck tube and hose connected to the fuel tank for clogging, dents and cracks.

# ON BOARD REFUELING VAPOR RECOVERY (ORVR)

[VQ37VHR FOR USA AND CANADA]

< DTC/CIRCUIT DIAGNOSIS >

Is the inspection result normal?

YES >> GO TO 15.

NO >> Replace fuel filler tube. Refer to [FL-10, "Exploded View"](#).

## 15.CHECK ONE-WAY FUEL VALVE-I

Check one-way valve for clogging.

Is the inspection result normal?

YES >> GO TO 16.

NO >> Repair or replace one-way fuel valve with fuel tank. Refer to [FL-10, "Exploded View"](#).

## 16.CHECK ONE-WAY FUEL VALVE-II

1. Make sure that fuel is drained from the tank.
2. Remove fuel filler tube and hose.
3. Check one-way fuel valve for operation as follows.  
When a stick is inserted, the valve should open, when removing stick it should close.

**Do not drop any material into the tank.**

Is the inspection result normal?

YES >> INSPECTION END

NO >> Replace fuel filler tube or replace one-way fuel valve with fuel tank. Refer to [FL-10, "Exploded View"](#).

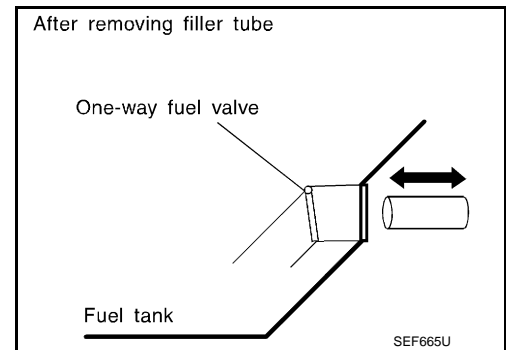

INFOID:000000006883180

## Component Inspection

### 1.INSPECTION START

Do you have CONSULT?

Do you have CONSULT?

YES >> GO TO 2.

NO >> GO TO 3.

### 2.CHECK REFUELING EVAP VAPOR CUT VALVE

**Ⓜ With CONSULT**

1. Turn ignition switch OFF.
2. Remove fuel tank. Refer to [FL-10, "Removal and Installation"](#).
3. Drain fuel from the tank as follows:
  - Remove fuel feed hose located on the fuel gauge retainer.
  - Connect a spare fuel hose, one side to fuel gauge retainer where the hose was removed and the other side to a fuel container.
  - Drain fuel using "FUEL PUMP RELAY" in "ACTIVE TEST" mode with CONSULT.
4. Check refueling EVAP vapor cut valve for being stuck to close as follows.  
Blow air into the refueling EVAP vapor cut valve (from the end of EVAP/ORVR line hose), and check that the air flows freely into the tank.
5. Check refueling EVAP vapor cut valve for being stuck to open as follows.
  - Connect vacuum pump to hose end.
  - Remove fuel gauge retainer with fuel gauge unit.

**Always replace O-ring with new one.**

  - Turn fuel tank upside down.

# ON BOARD REFUELING VAPOR RECOVERY (ORVR)

[VQ37VHR FOR USA AND CANADA]

## < DTC/CIRCUIT DIAGNOSIS >

- Apply vacuum pressure to hose end [-13.3 kPa (-0.136 kg/cm<sup>3</sup>, -1.93 psi)] with fuel gauge retainer remaining open and check that the pressure is applicable.

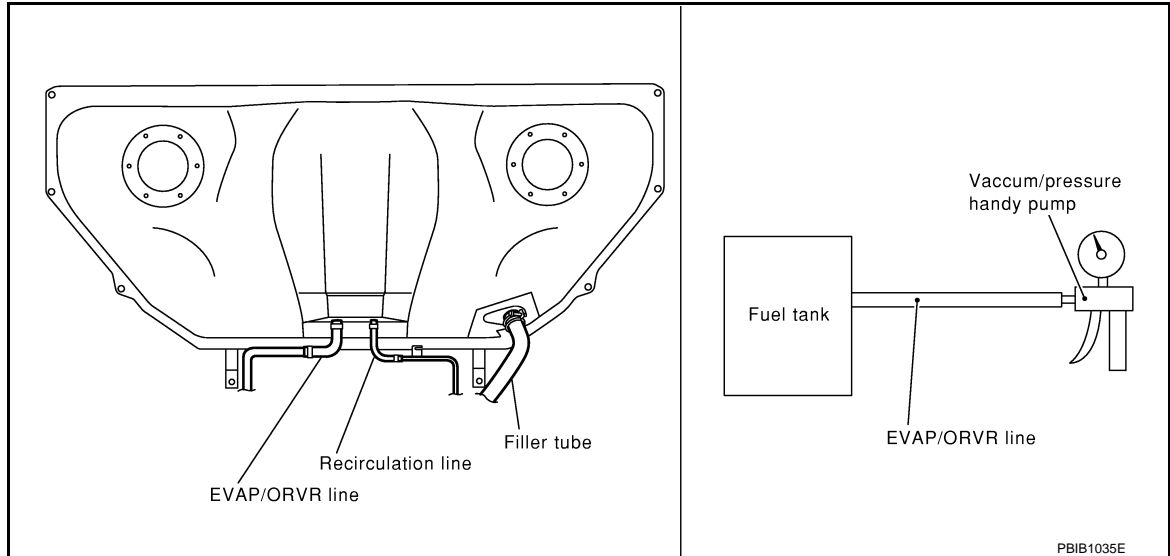

Is the inspection result normal?

- YES >> INSPECTION END
- NO >> Replace refueling EVAP vapor cut valve with fuel tank.

## 3. CHECK REFUELING EVAP VAPOR CUT VALVE

### ⊗ Without CONSULT

1. Turn ignition switch OFF.
  2. Remove fuel tank. Refer to [FL-10. "Removal and Installation"](#).
  3. Drain fuel from the tank as follows:
    - Remove fuel gauge retainer.
    - Drain fuel from the tank using a handy pump into a fuel container.
  4. Check refueling EVAP vapor cut valve for being stuck to close as follows.  
Blow air into the refueling EVAP vapor cut valve (from the end of EVAP/ORVR line hose), and check that the air flows freely into the tank.
  5. Check refueling EVAP vapor cut valve for being stuck to open as follows.
    - Connect vacuum pump to hose end.
    - Remove fuel gauge retainer with fuel gauge unit.
- Always replace O-ring with new one.**
- Turn fuel tank upside down.
  - Apply vacuum pressure to hose end [-13.3 kPa (-0.136 kg/cm<sup>3</sup>, -1.93 psi)] with fuel gauge retainer remaining open and check that the pressure is applicable.

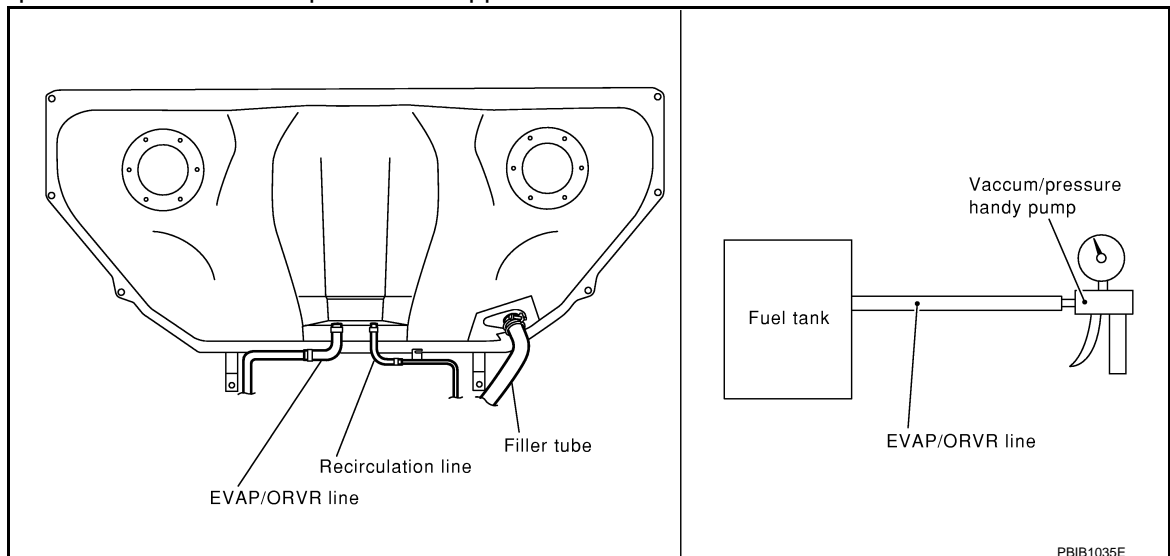



# ON BOARD REFUELING VAPOR RECOVERY (ORVR)

< DTC/CIRCUIT DIAGNOSIS >

[VQ37VHR FOR USA AND CANADA]

Is the inspection result normal?

YES >> INSPECTION END

NO >> Replace refueling EVAP vapor cut valve with fuel tank. Refer to [FL-10, "Exploded View"](#).

A

EC

C

D

E

F

G

H

I

J

K

L

M

N

O

P

# REFRIGERANT PRESSURE SENSOR

< DTC/CIRCUIT DIAGNOSIS >

[VQ37VHR FOR USA AND CANADA]

## REFRIGERANT PRESSURE SENSOR

### Component Function Check

INFOID:000000006883181

#### 1. CHECK REFRIGERANT PRESSURE SENSOR FUNCTION

1. Start engine and warm it up to normal operating temperature.
2. Turn A/C switch and blower fan switch ON.
3. Check the voltage between ECM harness connector terminals as per the following.

| Connector | ECM   |          | Voltage (V) |
|-----------|---|----------|-------------|
|           | +   | -        |             |
|           | Terminal                                    | Terminal |             |
| M107      | 105<br>(Refrigerant pressure sensor signal) | 112      | 1.0 - 4.0   |

Is the inspection result normal?

- YES >> INSPECTION END  
NO >> Go to [EC-530, "Diagnosis Procedure"](#).

### Diagnosis Procedure

INFOID:000000006883182

#### 1. CHECK GROUND CONNECTION

1. Turn A/C switch and blower fan switch OFF.
2. Turn ignition switch OFF.
3. Check ground connection M95. Refer to Ground Inspection in [GI-47, "Circuit Inspection"](#).

Is the inspection result normal?

- YES >> GO TO 2.  
NO >> Repair or replace ground connection.

#### 2. CHECK REFRIGERANT PRESSURE SENSOR POWER SUPPLY CIRCUIT

1. Disconnect refrigerant pressure sensor harness connector.
2. Turn ignition switch ON.
3. Check the voltage between refrigerant pressure sensor harness connector and ground.

| Refrigerant pressure sensor |          | Ground | Voltage (V) |
|-----------------------------|----------|--------|-------------|
| Connector                   | Terminal |        |             |
| E77                         | 3        | Ground | Approx. 5   |

Is the inspection result normal?

- YES >> GO TO 4.  
NO >> GO TO 3.

#### 3. DETECT MALFUNCTIONING PART

Check the following.

- Harness connectors M6, E106
- Harness for open or short between ECM and refrigerant pressure sensor

>> Repair open circuit, short to ground or short to power in harness or connectors.

#### 4. CHECK REFRIGERANT PRESSURE SENSOR GROUND CIRCUIT FOR OPEN AND SHORT

1. Turn ignition switch OFF.
2. Disconnect ECM harness connector.
3. Check the continuity between refrigerant pressure sensor harness connector and ECM harness connector.

# REFRIGERANT PRESSURE SENSOR

< DTC/CIRCUIT DIAGNOSIS >

[VQ37VHR FOR USA AND CANADA]

| Refrigerant pressure sensor |          | ECM       |          | Continuity |
|-----------------------------|----------|-----------|----------|------------|
| Connector                   | Terminal | Connector | Terminal |            |
| E77                         | 1        | M107      | 112      | Existed    |

4. Also check harness for short to ground and short to power.

Is the inspection result normal?

- YES >> GO TO 6.
- NO >> GO TO 5.

## 5. DETECT MALFUNCTIONING PART

Check the following.

- Harness connectors M6, E106
- Harness for open or short between ECM and refrigerant pressure sensor

>> Repair open circuit, short to ground or short to power in harness or connectors.

## 6. CHECK REFRIGERANT PRESSURE SENSOR INPUT SIGNAL CIRCUIT FOR OPEN AND SHORT

1. Check the continuity between refrigerant pressure sensor harness connector and ECM harness connector.

| Refrigerant pressure sensor |          | ECM       |          | Continuity |
|-----------------------------|----------|-----------|----------|------------|
| Connector                   | Terminal | Connector | Terminal |            |
| E77                         | 2        | M107      | 105      | Existed    |

2. Also check harness for short to ground and short to power.

Is the inspection result normal?

- YES >> GO TO 8.
- NO >> GO TO 7.

## 7. DETECT MALFUNCTIONING PART

Check the following.

- Harness connectors M6, E106
- Harness for open or short between ECM and refrigerant pressure sensor

>> Repair open circuit, short to ground or short to power in harness or connectors.

## 8. CHECK INTERMITTENT INCIDENT

Refer to [GI-44, "Intermittent Incident"](#).

Is the inspection result normal?

- YES >> Replace refrigerant pressure sensor. Refer to [HA-39, "Exploded View"](#).
- NO >> Repair or replace.

A  
EC  
C  
D  
E  
F  
G  
H  
I  
J  
K  
L  
M  
N  
O  
P

# ENGINE CONTROL SYSTEM SYMPTOMS

< SYMPTOM DIAGNOSIS >

[VQ37VHR FOR USA AND CANADA]

## SYMPTOM DIAGNOSIS

### ENGINE CONTROL SYSTEM SYMPTOMS

#### Symptom Table

INFOID:000000006883183

#### SYSTEM — BASIC ENGINE CONTROL SYSTEM

|   |                                       | SYMPTOM                          |              |                              |                        |                                 |                    |                    |                  |                        |                                  |                            |                           | Reference page |  |
|---|---------------------------------------|----------------------------------|--------------|------------------------------|------------------------|---------------------------------|--------------------|--------------------|------------------|------------------------|----------------------------------|----------------------------|---------------------------|----------------|--|
|   |                                       | HARD/NO START/RESTART (EXCP. HA) | ENGINE STALL | HESITATION/SURGING/FLAT SPOT | SPARK KNOCK/DETONATION | LACK OF POWER/POOR ACCELERATION | HIGH IDLE/LOW IDLE | ROUGH IDLE/HUNTING | IDLING VIBRATION | SLOW/NO RETURN TO IDLE | OVERHEATS/WATER TEMPERATURE HIGH | EXCESSIVE FUEL CONSUMPTION | EXCESSIVE OIL CONSUMPTION |                | BATTERY DEAD (UNDER CHARGE)  |
| Warranty symptom code                     |                                       | AA                               | AB           | AC                           | AD                     | AE                              | AF                 | AG                 | AH               | AJ                     | AK                               | AL                         | AM                        | HA             |  |
| Fuel                                      | Fuel pump circuit                     | 1                                | 1            | 2                            | 3                      | 2                               |                    | 2                  | 2                |                        |                                  | 3                          |                           | 2              | <a href="#">EC-514</a>   |
|   | Fuel pressure regulator system        | 3                                | 3            | 4                            | 4                      | 4                               | 4                  | 4                  | 4                | 4                      |                                  | 4                          |                           |                | <a href="#">EC-158</a>   |
|   | Fuel injector circuit                 | 1                                | 1            | 2                            | 3                      | 2                               |                    | 2                  | 2                |                        |                                  | 2                          |                           |                | <a href="#">EC-512</a>   |
|   | Evaporative emission system           | 3                                | 3            | 4                            | 4                      | 4                               | 4                  | 4                  | 4                | 4                      | 4                                | 4                          |                           |                | <a href="#">EC-65</a>  |
| Air                                       | Positive crankcase ventilation system | 3                                | 3            | 4                            | 4                      | 4                               | 4                  | 4                  | 4                | 4                      | 4                                | 4                          | 1                         |                | <a href="#">EC-542</a>   |
|   | Incorrect idle speed adjustment       |                                  |              |                              |                        |                                 | 1                  | 1                  | 1                | 1                      |                                  | 1                          |                           |                | <a href="#">EC-154</a>   |
|   | Electric throttle control actuator    | 1                                | 1            | 2                            | 3                      | 3                               | 2                  | 2                  | 2                | 2                      |                                  | 2                          |                           | 2              | <a href="#">EC-420</a> ,<br><a href="#">EC-427</a>   |
| Ignition                                  | Incorrect ignition timing adjustment  | 3                                | 3            | 1                            | 1                      | 1                               |                    | 1                  | 1                |                        |                                  | 1                          |                           |                | <a href="#">EC-154</a>   |
|   | Ignition circuit                      | 1                                | 1            | 2                            | 2                      | 2                               |                    | 2                  | 2                |                        |                                  | 2                          |                           |                | <a href="#">EC-519</a>   |
| Main power supply and ground circuit      |                                       | 2                                | 2            | 3                            | 3                      | 3                               |                    | 3                  | 3                |                        | 2                                | 3                          |                           |                | <a href="#">EC-180</a>   |
| Mass air flow sensor circuit              |                                       | 1                                |              |                              | 2                      |                                 |                    |                    |                  |                        |                                  |                            |                           |                | <a href="#">EC-201</a> ,<br><a href="#">EC-211</a>   |
| Engine coolant temperature sensor circuit |                                       |                                  |              |                              |                        |                                 | 3                  |                    |                  | 3                      |                                  |                            |                           |                | <a href="#">EC-231</a> ,<br><a href="#">EC-236</a>   |
| Air fuel ratio (A/F) sensor 1 circuit     |                                       |                                  | 1            | 2                            | 3                      | 2                               |                    | 2                  | 2                |                        |                                  | 2                          |                           |                | <a href="#">EC-243</a> ,<br><a href="#">EC-247</a> ,<br><a href="#">EC-250</a> ,<br><a href="#">EC-253</a> ,<br><a href="#">EC-499</a> |
| Throttle position sensor circuit          |                                       |                                  |              |                              |                        |                                 | 2                  |                    |                  | 2                      |                                  |                            |                           |                | <a href="#">EC-233</a> ,<br><a href="#">EC-300</a> ,<br><a href="#">EC-416</a> ,<br><a href="#">EC-418</a> ,<br><a href="#">EC-429</a> |
| Accelerator pedal position sensor circuit |                                       |                                  |              | 3                            | 2                      | 1                               |                    |                    |                  |                        |                                  |                            |                           |                | <a href="#">EC-485</a> ,<br><a href="#">EC-489</a> ,<br><a href="#">EC-494</a>   |
| Knock sensor circuit                      |                                       |                                  |              | 2                            |                        |                                 |                    |                    |                  |                        |                                  | 3                          |                           |                | <a href="#">EC-309</a>   |

# ENGINE CONTROL SYSTEM SYMPTOMS

< SYMPTOM DIAGNOSIS >

[VQ37VHR FOR USA AND CANADA]

|  | SYMPTOM                          |              |                              |                        |                                 |                    |                    |                  |                        |                                  |                            |                           |                             | Reference<br>page                                  |
|--|----------------------------------|--------------|------------------------------|------------------------|---------------------------------|--------------------|--------------------|------------------|------------------------|----------------------------------|----------------------------|---------------------------|-----------------------------|--|
|  | HARD/NO START/RESTART (EXCP. HA) | ENGINE STALL | HESITATION/SURGING/FLAT SPOT | SPARK KNOCK/DETONATION | LACK OF POWER/POOR ACCELERATION | HIGH IDLE/LOW IDLE | ROUGH IDLE/HUNTING | IDLING VIBRATION | SLOW/NO RETURN TO IDLE | OVERHEATS/WATER TEMPERATURE HIGH | EXCESSIVE FUEL CONSUMPTION | EXCESSIVE OIL CONSUMPTION | BATTERY DEAD (UNDER CHARGE) |  |
| Warranty symptom code                              | AA                               | AB           | AC                           | AD                     | AE                              | AF                 | AG                 | AH               | AJ                     | AK                               | AL                         | AM                        | HA                          |  |
| Engine oil temperature sensor                      |                                  |              | 4                            |                        | 1                               |                    |                    |                  |                        |                                  | 3                          |                           |                             | <a href="#">EC-294</a> ,<br><a href="#">EC-298</a> |
| Crankshaft position sensor (POS) circuit           | 2                                | 2            |                              |                        |                                 |                    |                    |                  |                        |                                  |                            |                           |                             | <a href="#">EC-312</a>                             |
| Camshaft position sensor (PHASE) circuit           | 3                                | 2            |                              |                        |                                 |                    |                    |                  |                        |                                  |                            |                           |                             | <a href="#">EC-316</a>                             |
| Vehicle speed signal circuit                       |                                  | 2            | 3                            |                        | 3                               |                    |                    |                  |                        |                                  | 3                          |                           |                             | <a href="#">EC-370</a>                             |
| Power steering pressure sensor circuit             |                                  | 2            |                              |                        |                                 |                    | 3                  | 3                |                        |                                  |                            |                           |                             | <a href="#">EC-381</a>                             |
| ECM  | 2                                | 2            | 3                            | 3                      | 3                               | 3                  | 3                  | 3                | 3                      | 3                                | 3                          |                           |                             | <a href="#">EC-383</a> ,<br><a href="#">EC-385</a> |
| Intake valve timing control solenoid valve circuit |                                  | 3            | 2                            |                        | 1                               | 3                  | 2                  | 2                | 3                      |                                  | 3                          |                           |                             | <a href="#">EC-208</a>                             |
| Manifold absolute pressure (MAP) sensor            |                                  |              |                              |                        |                                 |                    |                    |                  |                        |                                  | 3                          |                           |                             | <a href="#">EC-221</a>                             |
| VVEL control module                                | 3                                |              | 4                            | 4                      | 3                               |                    |                    |                  |                        |                                  |                            |                           |                             | <a href="#">EC-477</a> , <a href="#">EC-478</a>    |
| VVEL actuator motor                                | 3                                |              | 4                            | 4                      | 3                               |                    |                    |                  |                        |                                  |                            |                           |                             | <a href="#">EC-402</a>                             |
| VVEL actuator motor relay                          | 3                                |              | 4                            | 4                      | 3                               |                    |                    |                  |                        |                                  |                            |                           |                             | <a href="#">EC-406</a>                             |
| VVEL actuator shaft position sensor                | 3                                |              | 4                            | 4                      | 3                               |                    |                    |                  |                        |                                  |                            |                           |                             | <a href="#">EC-399</a>                             |
| PNP signal circuit                                 |                                  |              | 3                            |                        | 3                               |                    | 3                  | 3                |                        |                                  | 3                          |                           |                             | <a href="#">EC-391</a>                             |
| Refrigerant pressure sensor circuit                |                                  | 2            |                              |                        |                                 | 3                  |                    |                  | 3                      |                                  | 4                          |                           |                             | <a href="#">EC-530</a>                             |
| Electrical load signal circuit                     |                                  |              |                              |                        |                                 |                    | 3                  |                  |                        |                                  |                            |                           |                             | <a href="#">EC-510</a>                             |
| Air conditioner circuit                            | 2                                | 2            | 3                            | 3                      | 3                               | 3                  | 3                  | 3                | 3                      |                                  | 3                          |                           | 2                           | <a href="#">HAC-68</a>                             |
| ABS actuator and electric unit (control unit)      |                                  |              | 4                            |                        |                                 |                    |                    |                  |                        |                                  |                            |                           |                             | <a href="#">BRC-55</a>                             |

1 - 6: The numbers refer to the order of inspection.

(continued on next page)

## SYSTEM — ENGINE MECHANICAL & OTHER

A  
EC  
C  
D  
E  
F  
G  
H  
I  
J  
K  
L  
M  
N  
O  
P

# ENGINE CONTROL SYSTEM SYMPTOMS

< SYMPTOM DIAGNOSIS >

[VQ37VHR FOR USA AND CANADA]

|                       |   | SYMPTOM                          |              |                              |                        |                                 |                    |                    |                  |                        |                                  |                            |                           | Reference<br>page |   |                       |
|-----------------------|---|----------------------------------|--------------|------------------------------|------------------------|---------------------------------|--------------------|--------------------|------------------|------------------------|----------------------------------|----------------------------|---------------------------|-------------------|---|-----------------------|
|                       |   | HARD/NO START/RESTART (EXCP. HA) | ENGINE STALL | HESITATION/SURGING/FLAT SPOT | SPARK KNOCK/DETONATION | LACK OF POWER/POOR ACCELERATION | HIGH IDLE/LOW IDLE | ROUGH IDLE/HUNTING | IDLING VIBRATION | SLOW/NO RETURN TO IDLE | OVERHEATS/WATER TEMPERATURE HIGH | EXCESSIVE FUEL CONSUMPTION | EXCESSIVE OIL CONSUMPTION |                   | BATTERY DEAD (UNDER CHARGE)                       |                       |
| Warranty symptom code |   | AA                               | AB           | AC                           | AD                     | AE                              | AF                 | AG                 | AH               | AJ                     | AK                               | AL                         | AM                        | HA                |   |                       |
| Fuel                  | Fuel tank   | 5                                | 5            |                              |                        |                                 |                    |                    |                  |                        |                                  |                            |                           |                   | <a href="#">FL-12</a>                             |                       |
|                       | Fuel piping   |                                  |              | 5                            | 5                      | 5                               |                    | 5                  | 5                |                        | 5                                |                            |                           |                   | <a href="#">EM-48</a>                             |                       |
|                       | Vapor lock  |                                  |              |                              |                        |                                 |                    |                    |                  |                        |                                  |                            |                           |                   |   | —                     |
|                       | Valve deposit   |                                  |              |                              |                        |                                 |                    |                    |                  |                        |                                  |                            |                           |                   |   | —                     |
|                       | Poor fuel (Heavy weight gasoline, Low octane)   | 5                                |              |                              | 5                      | 5                               | 5                  |                    | 5                | 5                      |                                  |                            | 5                         |                   |   | —                     |
| Air                   | Air duct  |                                  | 5            |                              |                        |                                 |                    |                    |                  |                        |                                  |                            |                           |                   | <a href="#">EM-30</a>                             |                       |
|                       | Air cleaner   |                                  |              |                              |                        |                                 |                    |                    |                  |                        |                                  |                            |                           |                   | <a href="#">EM-30</a>                             |                       |
|                       | Air leakage from air duct (Mass air flow sensor — electric throttle control actuator) | 5                                |              | 5                            | 5                      | 5                               |                    | 5                  | 5                |                        |                                  | 5                          |                           |                   | <a href="#">EM-30</a>                             |                       |
|                       | Electric throttle control actuator  |                                  |              |                              | 5                      |                                 | 5                  |                    |                  | 5                      |                                  |                            |                           |                   | <a href="#">EM-31</a>                             |                       |
|                       | Air leakage from intake manifold/Collector/Gasket                                     |                                  |              |                              |                        |                                 |                    |                    |                  |                        |                                  |                            |                           |                   |   | <a href="#">EM-35</a> |
| Cranking              | Battery   |                                  | 1            | 1                            |                        | 1                               |                    | 1                  | 1                |                        |                                  |                            |                           | 1                 | <a href="#">PG-142</a>                            |                       |
|                       | Generator circuit   | 1                                |              |                              |                        | 1                               |                    |                    |                  |                        |                                  |                            |                           |                   | <a href="#">CHG-14,</a><br><a href="#">CHG-15</a> |                       |
|                       | Starter circuit   | 3                                |              |                              |                        |                                 |                    |                    |                  |                        |                                  | 1                          |                           |                   | <a href="#">STR-18</a>                            |                       |
|                       | Signal plate  | 6                                |              |                              |                        |                                 |                    |                    |                  |                        |                                  |                            |                           |                   | <a href="#">EM-132</a>                            |                       |
|                       | PNP signal circuit  | 4                                |              |                              |                        |                                 |                    |                    |                  |                        |                                  |                            |                           |                   | <a href="#">TM-102</a>                            |                       |
| Engine                | Cylinder head   | 5                                | 5            | 5                            | 5                      | 5                               |                    | 5                  | 5                |                        |                                  | 5                          |                           |                   | <a href="#">EM-119</a>                            |                       |
|                       | Cylinder head gasket  |                                  |              |                              |                        |                                 |                    |                    |                  |                        | 4                                |                            | 3                         |                   |   |                       |
|                       | Cylinder block  |                                  |              |                              |                        |                                 |                    |                    |                  |                        |                                  |                            |                           |                   |   |                       |
|                       | Piston  |                                  |              |                              |                        |                                 |                    |                    |                  |                        |                                  |                            | 4                         |                   |   |                       |
|                       | Piston ring   |                                  |              |                              |                        |                                 |                    |                    |                  |                        |                                  |                            |                           |                   |   |                       |
|                       | Connecting rod  | 6                                |              | 6                            | 6                      | 6                               | 6                  |                    | 6                | 6                      |                                  |                            | 6                         |                   | <a href="#">EM-132</a>                            |                       |
|                       | Bearing   |                                  |              |                              |                        |                                 |                    |                    |                  |                        |                                  |                            |                           |                   |   |                       |
|                       | Crankshaft  |                                  |              |                              |                        |                                 |                    |                    |                  |                        |                                  |                            |                           |                   |   |                       |
| Valve mechanism       | Timing chain  | 5                                | 5            | 5                            | 5                      | 5                               |                    | 5                  | 5                |                        |                                  | 5                          |                           |                   | <a href="#">EM-67</a>                             |                       |
|                       | Camshaft  |                                  |              |                              |                        |                                 |                    |                    |                  |                        |                                  |                            |                           |                   | <a href="#">EM-106</a>                            |                       |
|                       | Intake valve timing control   |                                  |              |                              |                        |                                 |                    |                    |                  |                        |                                  |                            |                           |                   |   | <a href="#">EM-67</a> |
|                       | Intake valve  |                                  |              |                              |                        |                                 |                    |                    |                  |                        |                                  |                            |                           |                   |   |                       |
|                       | Exhaust valve   |                                  |              |                              |                        |                                 |                    |                    |                  |                        |                                  |                            |                           |                   |   | 3                     |

# ENGINE CONTROL SYSTEM SYMPTOMS

< SYMPTOM DIAGNOSIS >

[VQ37VHR FOR USA AND CANADA]

|   |  | SYMPTOM                          |              |                              |                        |                                 |                    |                    |                  |                        |                                  |                            |                           | Reference<br>page |  |
|---|--|----------------------------------|--------------|------------------------------|------------------------|---------------------------------|--------------------|--------------------|------------------|------------------------|----------------------------------|----------------------------|---------------------------|-------------------|--|
|   |  | HARD/NO START/RESTART (EXCP. HA) | ENGINE STALL | HESITATION/SURGING/FLAT SPOT | SPARK KNOCK/DETONATION | LACK OF POWER/POOR ACCELERATION | HIGH IDLE/LOW IDLE | ROUGH IDLE/HUNTING | IDLING VIBRATION | SLOW/NO RETURN TO IDLE | OVERHEATS/WATER TEMPERATURE HIGH | EXCESSIVE FUEL CONSUMPTION | EXCESSIVE OIL CONSUMPTION |                   | BATTERY DEAD (UNDER CHARGE)  |
| Warranty symptom code                             |  | AA                               | AB           | AC                           | AD                     | AE                              | AF                 | AG                 | AH               | AJ                     | AK                               | AL                         | AM                        | HA                |  |
| Exhaust   | Exhaust manifold/Tube/Muffler/Gasket                 | 5                                | 5            | 5                            | 5                      | 5                               |                    | 5                  | 5                |                        |                                  | 5                          |                           |                   | <a href="#">EM-38</a> ,<br><a href="#">EX-4</a>                          |
|   | Three way catalyst                                   |                                  |              |                              |                        |                                 |                    |                    |                  |                        |                                  |                            |                           |                   |  |
| Lubrica-<br>tion                                  | Oil pan/Oil strainer/Oil pump/Oil filter/Oil gallery | 5                                | 5            | 5                            | 5                      | 5                               |                    | 5                  | 5                |                        |                                  | 5                          |                           |                   | <a href="#">EM-48</a> ,<br><a href="#">LU-11</a> , <a href="#">LU-15</a> |
|   | Oil level (Low)/Filthy oil                           |                                  |              |                              |                        |                                 |                    |                    |                  |                        |                                  |                            |                           |                   | <a href="#">LU-7</a>   |
| Cooling   | Radiator/Hose/Radiator filler cap                    |                                  |              |                              |                        |                                 |                    |                    |                  |                        |                                  |                            |                           |                   | <a href="#">CO-12</a> ,<br><a href="#">CO-12</a>                         |
|   | Thermostat   |                                  |              |                              |                        |                                 |                    |                    |                  | 5                      |                                  |                            |                           |                   | <a href="#">CO-24</a>  |
|   | Water pump   | 5                                | 5            | 5                            | 5                      | 5                               |                    | 5                  | 5                |                        | 4                                | 5                          |                           |                   | <a href="#">CO-22</a>  |
|   | Water gallery  |                                  |              |                              |                        |                                 |                    |                    |                  |                        |                                  |                            |                           |                   | <a href="#">CO-26</a>  |
|   | Cooling fan  |                                  |              |                              |                        |                                 |                    |                    |                  |                        |                                  |                            |                           |                   | <a href="#">CO-19</a>  |
|   | Coolant level (Low)/Contaminated coolant             |                                  |              |                              |                        |                                 |                    |                    |                  | 5                      |                                  |                            |                           |                   | <a href="#">CO-8</a>   |
| IVIS (INFINITI Vehicle Immobilizer System — NATS) |  | 1                                | 1            |                              |                        |                                 |                    |                    |                  |                        |                                  |                            |                           |                   | <a href="#">SEC-36</a>   |

1 - 6: The numbers refer to the order of inspection.

A  
EC  
C  
D  
E  
F  
G  
H  
I  
J  
K  
L  
M  
N  
O  
P

# INFINITI DRIVE MODE SELECTOR

< SYMPTOM DIAGNOSIS >

[VQ37VHR FOR USA AND CANADA]

## INFINITI DRIVE MODE SELECTOR

### Symptom Table

INFOID:000000006883184

#### SYSTEM - DRIVE MODE SELECTOR -

| Malfunction  | Check item  |  | Probable malfunctioning part/Action  |
|--|---|--|--|
| ECO pedal reaction force is not generated when in ECO mode.  | Only ECO pedal reaction force is not generated.<br>[Intelligent pedal (distance control assist) operates normally.] | The central switch of the navigation system operates normally. | Perform self-diagnosis of the engine control system.<br>Refer to <a href="#">EC-117, "DTC Index"</a> .   |
|  |   | The central switch of the navigation system malfunctions.      | Perform self-diagnosis of the navigation system.<br>Refer to <a href="#">AV-97, "Symptom Table"</a> (BASE AUDIO WITHOUT NAVIGATION) or <a href="#">AV-252, "Symptom Table"</a> (BOSE AUDIO WITH NAVIGATION)  |
|  | Intelligent pedal (distance control assist) reaction force is not generated as well.                                |  | Perform self-diagnosis of the ADAS control unit, ICC sensor, and Accelerator pedal actuator.<br><ul style="list-style-type: none"> <li>• ADAS C/U: Refer to <a href="#">DAS-40, "DTC Index"</a>.</li> <li>• ICC SENSOR: Refer to <a href="#">DAS-98, "DTC Index"</a>.</li> <li>• ACCELERATOR PEDAL ACTUATOR: Refer to <a href="#">DAS-101, "DTC Index"</a>.</li> </ul> |
| When in ECO mode, settings of ECO pedal reaction force cannot be changed or vehicle behavior does not agree to the settings. | Intelligent pedal (distance control assist) reaction force has a malfunction as well.                               |  | Perform self-diagnosis of the ADAS control unit, ICC sensor, and Accelerator pedal actuator.<br><ul style="list-style-type: none"> <li>• ADAS C/U: Refer to <a href="#">DAS-40, "DTC Index"</a>.</li> <li>• ICC SENSOR: Refer to <a href="#">DAS-98, "DTC Index"</a>.</li> <li>• ACCELERATOR PEDAL ACTUATOR: Refer to <a href="#">DAS-101, "DTC Index"</a>.</li> </ul> |
|  | Intelligent pedal (distance control assist) reaction force is normal.   | The central switch of the navigation system operates normally. | Perform self-diagnosis of the engine control system.<br>Refer to <a href="#">EC-117, "DTC Index"</a> .   |
|  |   | The central switch of the navigation system malfunctions.      | Perform self-diagnosis of the navigation system.<br>Refer to <a href="#">AV-97, "Symptom Table"</a> (BASE AUDIO WITHOUT NAVIGATION) or <a href="#">AV-252, "Symptom Table"</a> (BOSE AUDIO WITH NAVIGATION)  |



# NORMAL OPERATING CONDITION

< SYMPTOM DIAGNOSIS >

[VQ37VHR FOR USA AND CANADA]

## NORMAL OPERATING CONDITION

### Description

INFOID:000000006883185

#### FUEL CUT CONTROL (AT NO LOAD AND HIGH ENGINE SPEED)

If the engine speed is above 2,400 rpm under no load (for example, the selector lever position is neutral and engine speed is over 2,400 rpm) fuel will be cut off after some time. The exact time when the fuel is cut off varies based on engine speed. However, if the engine speed is above 4,500 rpm, fuel will be cut off in a few seconds. Fuel cut will be operated until the engine speed reaches 1,500 rpm, then fuel cut will be cancelled.

**NOTE:**

This function is different from deceleration control listed under Multiport Fuel Injection (MFI) System, [EC-58. "MULTIPOINT FUEL INJECTION SYSTEM : System Description"](#).

#### TORQUE CUT CONTROL (AT HIGH ENGINE OIL TEMPERATURE)

ECM receives engine oil temperature signal from engine oil temperature sensor.

To avoid VVEL performance, ECM performs the engine torque cut control at high engine oil temperature.

If engine oil temperature is too high, engine oil viscosity will change. As a result, engine oil pressure is decreased. This control is to control the VVEL operating angle by operating the VVEL actuator sub assembly. If this control is operated, engine performance will decrease, then maximum engine speed is reduced a little, for example.

**NOTE:**

If the engine oil temperature sensor is deteriorated, its characteristic will change.

In this case, the operating temperature for engine torque cut control might be decrease.

Perform Component Inspection of the engine oil temperature sensor to check for the deterioration.

Refer to [EC-296. "Component Inspection"](#).

A  
EC  
C  
D  
E  
F  
G  
H  
I  
J  
K  
L  
M  
N  
O  
P

---

## PERIODIC MAINTENANCE

### IDLE SPEED

#### Inspection

INFOID:000000006883186

#### CHECK IDLE SPEED

 **With CONSULT**

Check idle speed in “DATA MONITOR” mode of “ENGINE” using CONSULT.

 **With GST**

Check idle speed with Service \$01 of GST.

# IGNITION TIMING

< PERIODIC MAINTENANCE >

[VQ37VHR FOR USA AND CANADA]

## IGNITION TIMING

### Inspection

INFOID:000000006883187

### CHECK IGNITION TIMING

1. Attach timing light to loop wire as shown.

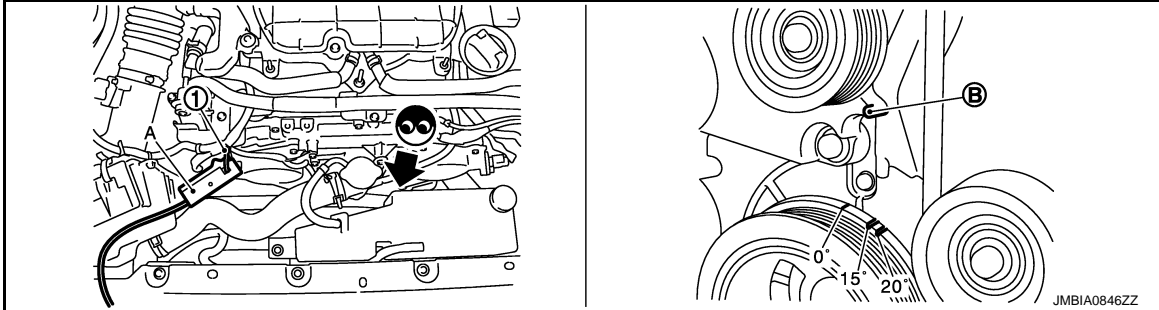

1. Loop wire
- A. Timing light
- B. Timing indicator

2. Check ignition timing.

A

EC

C

D

E

F

G

H

I

J

K

L

M

N

O

P

# EVAP LEAK CHECK

< PERIODIC MAINTENANCE >

[VQ37VHR FOR USA AND CANADA]

## EVAP LEAK CHECK

### Inspection

INFOID:000000006883188

#### CAUTION:

- Do not use compressed air or a high pressure pump.
- Do not exceed 4.12 kPa (0.042 kg/cm<sup>2</sup>, 0.6 psi) of pressure in EVAP system.

#### NOTE:

- Do not start engine.
- Improper installation of EVAP service port adapter to the EVAP service port may cause a leak.

#### Ⓟ WITH CONSULT

1. To locate the EVAP leak, install EVAP service port adapter and pressure pump to EVAP service port.
2. Turn ignition switch ON.
3. Select the "EVAP SYSTEM CLOSE" of "WORK SUPPORT" mode with CONSULT.
4. Touch "START". A bar graph (Pressure indicating display) will appear on the screen.
5. Apply positive pressure to the EVAP system until the pressure indicator reaches the middle of the bar graph.
6. Remove EVAP service port adapter and hose with pressure pump.
7. Locate the leak using a leak detector. Refer to [EC-65. "EVAPORATIVE EMISSION SYSTEM : System Diagram"](#).

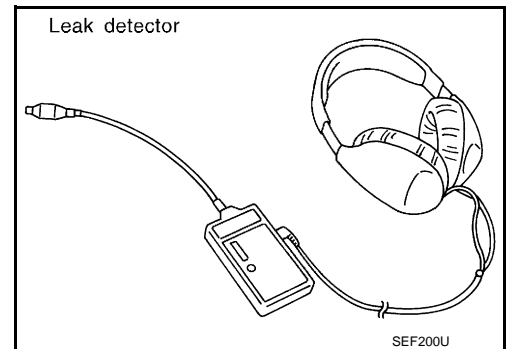
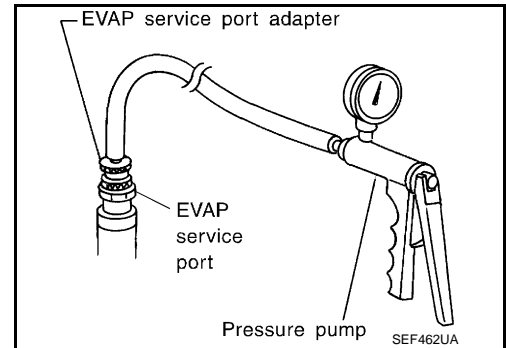

#### ⓧ WITHOUT CONSULT

1. To locate the EVAP leak, install EVAP service port adapter and pressure pump to EVAP service port.
2. Apply battery voltage between the terminals of EVAP canister vent control valve to make a closed EVAP system.
3. To locate the leak, deliver positive pressure to the EVAP system until pressure gauge points reach 1.38 to 2.76 kPa (0.014 to 0.028 kg/cm<sup>2</sup>, 0.2 to 0.4 psi).
4. Remove EVAP service port adapter and hose with pressure pump.

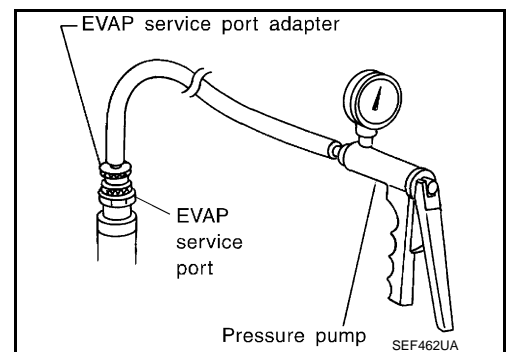

# EVAP LEAK CHECK

< PERIODIC MAINTENANCE >

[VQ37VHR FOR USA AND CANADA]

5. Locate the leak using a leak detector. Refer to [EC-65. "EVAPORATIVE EMISSION SYSTEM : System Diagram"](#).

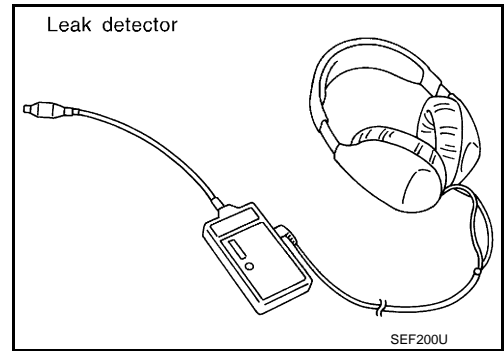

A  
EC  
C  
D  
E  
F  
G  
H  
I  
J  
K  
L  
M  
N  
O  
P

# POSITIVE CRANKCASE VENTILATION

< PERIODIC MAINTENANCE >

[VQ37VHR FOR USA AND CANADA]

## POSITIVE CRANKCASE VENTILATION

### Inspection

INFOID:000000006883189

#### 1. CHECK PCV VALVE

With engine running at idle, remove PCV valve from rocker cover. A properly working valve makes a hissing noise as air passes through it. A strong vacuum should be felt immediately when a finger is placed over valve inlet.

Is the inspection result normal?

- YES >> INSPECTION END
- NO >> Replace PCV valve.

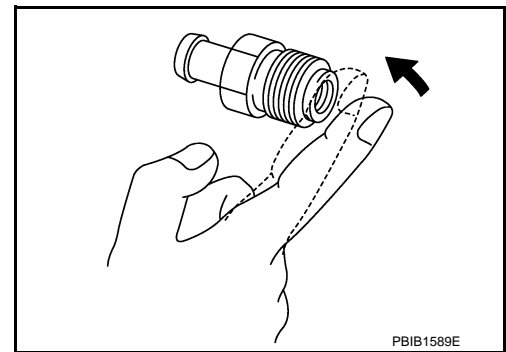

# REMOVAL AND INSTALLATION

## ECM

### Removal and Installation

INFOID:000000006883190

#### REMOVAL

1. Remove the instrument lower cover. Refer to [IP-12, "Exploded View"](#).
2. Remove the dash side finisher (LH). Refer to [INT-34, "DASH SIDE FINISHER : Removal and Installation"](#).
3. Remove the ECM cover bolts (A) and remove ECM cover (1).

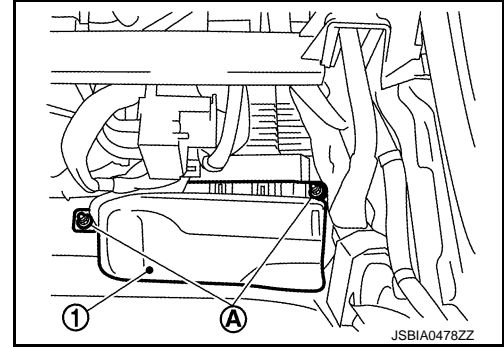

4. Disconnect ECM harness connectors.
5. Remove ECM bracket bolt (A)
6. Slide the ECM bracket (1) upward and then remove ECM bracket with ECM.
7. Remove ECM bracket bolts (B) and separate ECM (2) and ECM bracket.

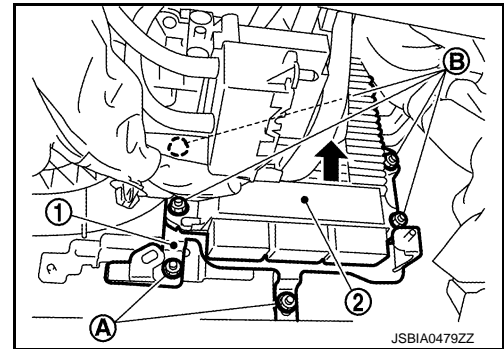

#### INSTALLATION

Install in the reverse order of removal.

**CAUTION:**

**Must be perform additional service when replacing ECM. Refer to [EC-144, "Work Procedure"](#).**

# VVEL CONTROL MODULE

< REMOVAL AND INSTALLATION >

[VQ37VHR FOR USA AND CANADA]

## VVEL CONTROL MODULE

### Removal and Installation

INFOID:000000006883191

#### REMOVAL

1. Remove hoodledge cover (RH) and cowl top cover (RH). Refer to [EXT-21, "Exploded View"](#).
2. Remove the battery and battery tray. Refer to [PG-142, "Exploded View"](#).
3. Remove VVEL control module bracket bolts (A).
4. Remove the ground harness fix bolt (B).
5. Remove VVEL control module bracket (1).

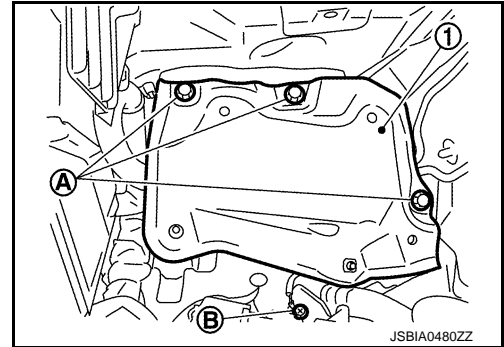

6. Disconnect VVEL control module harness connector.
7. Remove the fix bolts (A). And then separate VVEL control module (1), ground harness (2) and VVEL control module bracket (3).

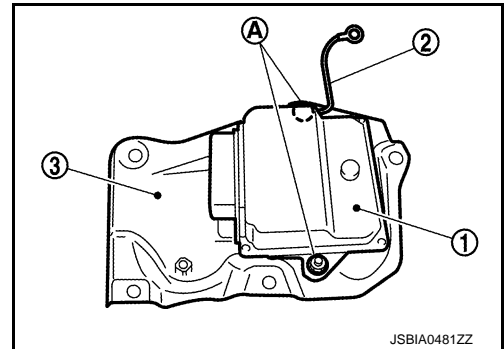

#### INSTALLATION

Install in the reverse order of removal.

#### **CAUTION:**

**Must be perform additional service when replacing VVEL control module. Refer to [EC-145, "Work Procedure"](#).**



# SERVICE DATA AND SPECIFICATIONS (SDS)

< SERVICE DATA AND SPECIFICATIONS (SDS)

[VQ37VHR FOR USA AND CANADA]

## SERVICE DATA AND SPECIFICATIONS (SDS)

### SERVICE DATA AND SPECIFICATIONS (SDS)

#### Idle Speed

INFOID:0000000006883197

EC

| Condition                     | Specification |
|-------------------------------|---------------|
| No load* (in P or N position) | 650 ± 50 rpm  |

\*: Under the following conditions

- A/C switch: OFF
- Electric load: OFF (Lights, heater fan & rear window defogger)
- Steering wheel: Kept in straight-ahead position

#### Ignition Timing

INFOID:0000000006883198

| Condition                     | Specification |
|-------------------------------|---------------|
| No load* (in P or N position) | 10 ± 2° BTDC  |

\*: Under the following conditions

- A/C switch: OFF
- Electric load: OFF (Lights, heater fan & rear window defogger)
- Steering wheel: Kept in straight-ahead position

#### Calculated Load Value

INFOID:0000000006883199

| Condition    | Specification (Using CONSULT or GST) |
|--------------|--------------------------------------|
| At idle      | 5 – 35 %                             |
| At 2,500 rpm | 5 – 35 %                             |

#### Mass Air Flow Sensor

INFOID:0000000006883200

|                                      |  |
|--------------------------------------|--|
| Supply voltage                       | Battery voltage (11 – 14 V)                            |
| Output voltage at idle               | 0.7 – 1.2 V*   |
| Mass air flow (Using CONSULT or GST) | 2.0 – 6.0 g/s at idle*<br>7.0 – 20.0 g/s at 2,500 rpm* |

\*: Engine is warmed up to normal operating temperature and running under no load.

## PRECAUTION

### PRECAUTIONS

#### Precaution for Supplemental Restraint System (SRS) "AIR BAG" and "SEAT BELT PRE-TENSIONER"

INFOID:000000007729617

The Supplemental Restraint System such as "AIR BAG" and "SEAT BELT PRE-TENSIONER", used along with a front seat belt, helps to reduce the risk or severity of injury to the driver and front passenger for certain types of collision. This system includes seat belt switch inputs and dual stage front air bag modules. The SRS system uses the seat belt switches to determine the front air bag deployment, and may only deploy one front air bag, depending on the severity of a collision and whether the front occupants are belted or unbelted. Information necessary to service the system safely is included in the "SRS AIR BAG" and "SEAT BELT" of this Service Manual.

**WARNING:**

Always observe the following items for preventing accidental activation.

- To avoid rendering the SRS inoperative, which could increase the risk of personal injury or death in the event of a collision that would result in air bag inflation, all maintenance must be performed by an authorized NISSAN/INFINITI dealer.
- Improper maintenance, including incorrect removal and installation of the SRS, can lead to personal injury caused by unintentional activation of the system. For removal of Spiral Cable and Air Bag Module, see "SRS AIR BAG".
- Never use electrical test equipment on any circuit related to the SRS unless instructed to in this Service Manual. SRS wiring harnesses can be identified by yellow and/or orange harnesses or harness connectors.

#### PRECAUTIONS WHEN USING POWER TOOLS (AIR OR ELECTRIC) AND HAMMERS

**WARNING:**

Always observe the following items for preventing accidental activation.

- When working near the Air Bag Diagnosis Sensor Unit or other Air Bag System sensors with the ignition ON or engine running, never use air or electric power tools or strike near the sensor(s) with a hammer. Heavy vibration could activate the sensor(s) and deploy the air bag(s), possibly causing serious injury.
- When using air or electric power tools or hammers, always switch the ignition OFF, disconnect the battery, and wait at least 3 minutes before performing any service.

#### Precaution for Procedure without Cowl Top Cover

INFOID:000000007729618

When performing the procedure after removing cowl top cover, cover the lower end of windshield with urethane, etc.

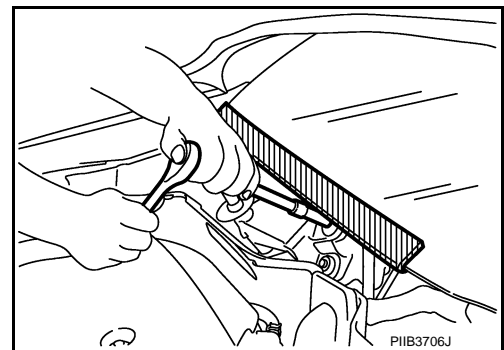

#### Precautions For Xenon Headlamp Service

INFOID:000000007729619

**WARNING:**

Comply with the following warnings to prevent any serious accident.

- Disconnect the battery cable (negative terminal) or the power supply fuse before installing, removing, or touching the xenon headlamp (bulb included). The xenon headlamp contains high-voltage generated parts.
- Never work with wet hands.
- Check the xenon headlamp ON-OFF status after assembling it to the vehicle. Never turn the xenon headlamp ON in other conditions. Connect the power supply to the vehicle-side connector.

# PRECAUTIONS

[VQ37VHR FOR MEXICO]

< PRECAUTION >

(Turning it ON outside the lamp case may cause fire or visual impairments.)

- Never touch the bulb glass immediately after turning it OFF. It is extremely hot.

## CAUTION:

Comply with the following cautions to prevent any error and malfunction.

- Install the xenon bulb securely. (Insufficient bulb socket installation may melt the bulb, the connector, the housing, etc. by high-voltage leakage or corona discharge.)
- Never perform HID circuit inspection with a tester.
- Never touch the xenon bulb glass with hands. Never put oil and grease on it.
- Dispose of the used xenon bulb after packing it in thick vinyl without breaking it.
- Never wipe out dirt and contamination with organic solvent (thinner, gasoline, etc.).

## On Board Diagnostic (OBD) System of Engine and A/T

INFOID:000000007729620

The ECM has an on board diagnostic system. It will illuminate the malfunction indicator lamp (MIL) to warn the driver of a malfunction causing emission deterioration.

## CAUTION:

- Always turn the ignition switch OFF and disconnect the negative battery cable before any repair or inspection work. The open/short circuit of related switches, sensors, solenoid valves, etc. will cause the MIL to illuminate.
- Always connect and lock the connectors securely after work. A loose (unlocked) connector will cause the MIL to illuminate due to the open circuit. (Be sure the connector is free from water, grease, dirt, bent terminals, etc.)
- Certain systems and components, especially those related to OBD, may use a new style slide-locking type harness connector. For description and how to disconnect, refer to [PG-5, "Harness Connector"](#).
- Always route and secure the harnesses properly after work. The interference of the harness with a bracket, etc. may cause the MIL to illuminate due to the short circuit.
- Always connect rubber tubes properly after work. A misconnected or disconnected rubber tube may cause the MIL to illuminate due to the malfunction of the EVAP system or fuel injection system, etc.
- Always erase the unnecessary malfunction information (repairs completed) from the ECM and TCM (Transmission control module) before returning the vehicle to the customer.

## General Precautions

INFOID:000000007729621

- Always use a 12 volt battery as power source.
- Never attempt to disconnect battery cables while engine is running.
- Before connecting or disconnecting the ECM harness connector, turn ignition switch OFF and disconnect negative battery cable. Failure to do so may damage the ECM because battery voltage is applied to ECM even if ignition switch is turned OFF.
- Before removing parts, turn ignition switch OFF and then disconnect negative battery cable.

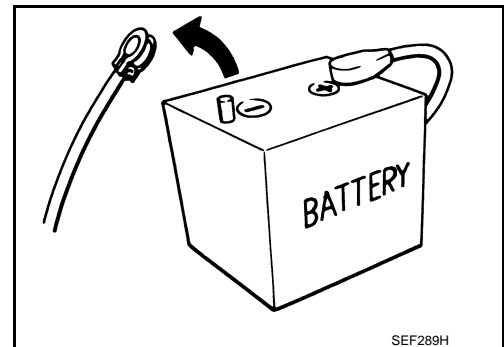

- Never disassemble ECM.
- If a battery cable is disconnected, the memory will return to the ECM value.  
The ECM will now start to self-control at its initial value. Thus, engine operation can vary slightly in this case. However, this is not an indication of a malfunction. Never replace parts because of a slight variation.
- If the battery is disconnected, the following emission-related diagnostic information will be cleared within 24 hours.
  - Diagnostic trouble codes
  - 1st trip diagnostic trouble codes
  - Freeze frame data
  - 1st trip freeze frame data
  - System readiness test (SRT) codes
  - Test values

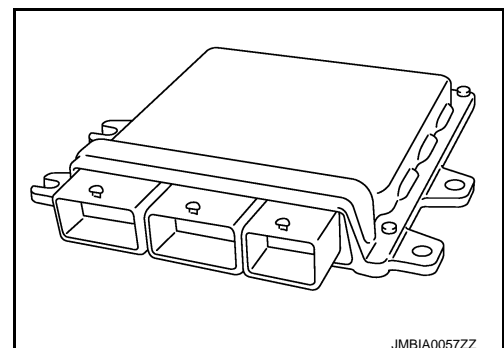

# PRECAUTIONS

[VQ37VHR FOR MEXICO]

## < PRECAUTION >

- When connecting ECM harness connector (A), fasten (B) it securely with a lever as far as it will go as shown in the figure.
- 1 : ECM
- C : Loosen

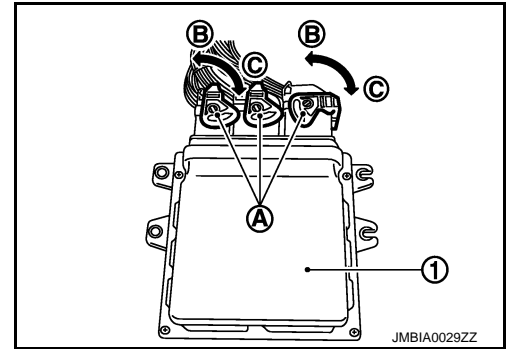

- When connecting or disconnecting pin connectors into or from ECM, never damage pin terminals (bends or break). Make sure that there are not any bends or breaks on ECM pin terminal, when connecting pin connectors.
- Securely connect ECM harness connectors. A poor connection can cause an extremely high (surge) voltage to develop in coil and condenser, thus resulting in damage to ICs.
- Keep engine control system harness at least 10 cm (4 in) away from adjacent harness, to prevent engine control system malfunctions due to receiving external noise, degraded operation of ICs, etc.
- Keep engine control system parts and harness dry.
- Before replacing ECM, perform ECM Terminals and Reference Value inspection and make sure ECM functions properly. Refer to [EC-609, "Reference Value"](#).
- Handle mass air flow sensor carefully to avoid damage.
- Never clean mass air flow sensor with any type of detergent.
- Never disassemble electric throttle control actuator.
- Even a slight leak in the air intake system can cause serious incidents.
- Never shock or jar the camshaft position sensor (PHASE), crankshaft position sensor (POS).

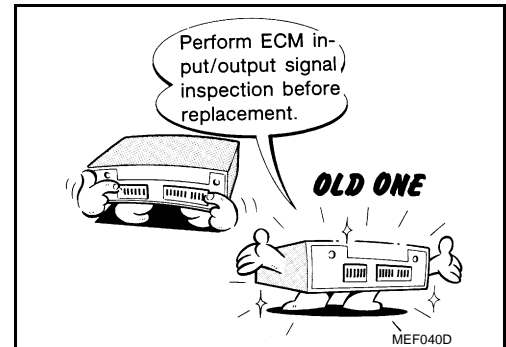
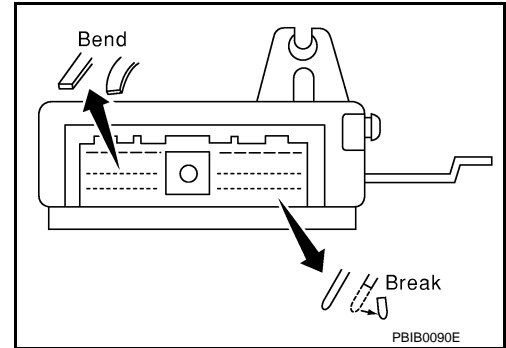

- After performing each TROUBLE DIAGNOSIS, perform DTC Confirmation Procedure or Component Function Check. The DTC should not be displayed in the DTC Confirmation Procedure if the repair is completed. The Component Function Check should be a good result if the repair is completed.

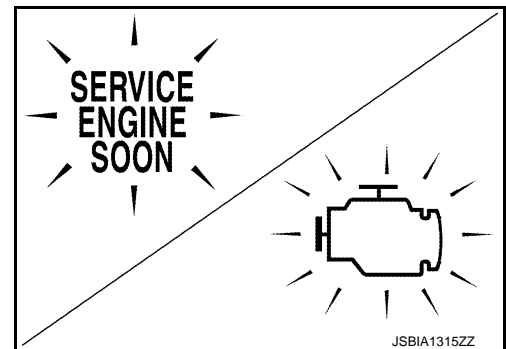

# PRECAUTIONS

[VQ37VHR FOR MEXICO]

## < PRECAUTION >

- When measuring ECM signals with a circuit tester, never allow the two tester probes to contact. Accidental contact of probes will cause a short circuit and damage the ECM power transistor.

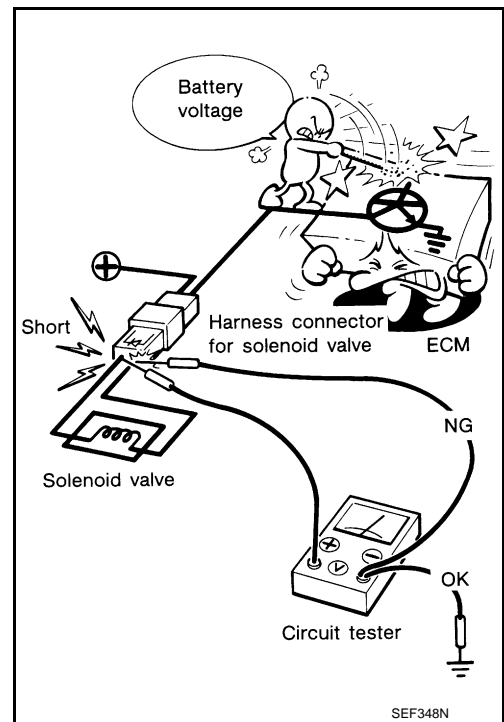

- B1 indicates bank 1, B2 indicates bank 2 as shown in the figure.
- Never operate fuel pump when there is no fuel in lines.
- Tighten fuel hose clamps to the specified torque.

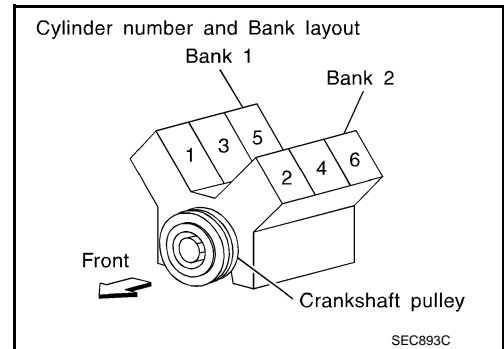

- Never depress accelerator pedal when starting.
- Immediately after starting, never rev up engine unnecessarily.
- Never rev up engine just prior to shutdown.

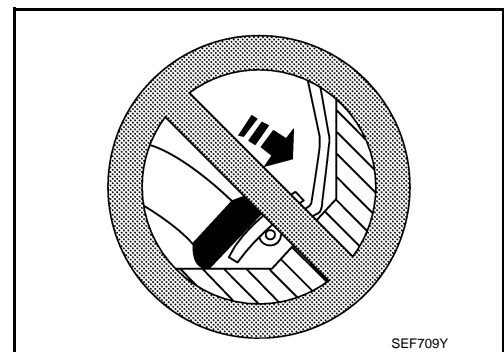

A  
EC  
C  
D  
E  
F  
G  
H  
I  
J  
K  
L  
M  
N  
O  
P

## PRECAUTIONS

[VQ37VHR FOR MEXICO]

### < PRECAUTION >

- When installing C.B. ham radio or a mobile phone, be sure to observe the following as it may adversely affect electronic control systems depending on installation location.
- Keep the antenna as far as possible from the electronic control units.
- Keep the antenna feeder line more than 20 cm (8 in) away from the harness of electronic controls. Never let them run parallel for a long distance.
- Adjust the antenna and feeder line so that the standing-wave ratio can be kept smaller.
- Be sure to ground the radio to vehicle body.

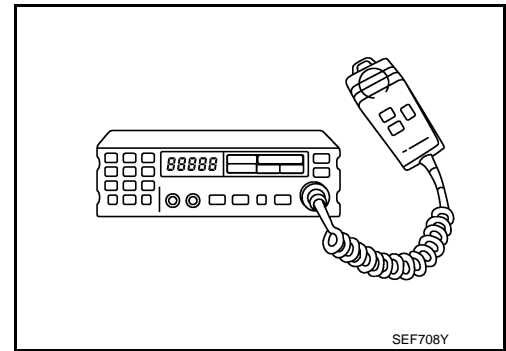

PREPARATION

PREPARATION

Special Service Tools

INFOID:000000007729622

A

EC

**NOTE:**

The actual shapes of Kent-Moore tools may differ from those of special service tools illustrated here.

C

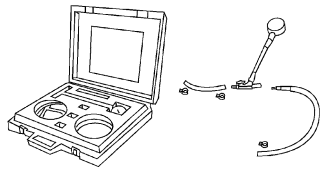
| Tool number<br>(Kent-Moore No.)<br>Tool name  | Description          |
|---|----------------------|
| (J-44321)<br>Fuel pressure gauge<br>kit<br> LEC642 | Checks fuel pressure |

D

E

F

Commercial Service Tools

INFOID:000000007729623

G

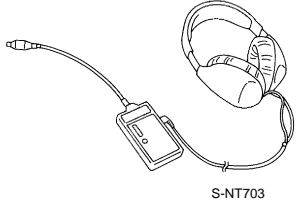
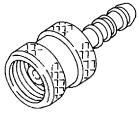
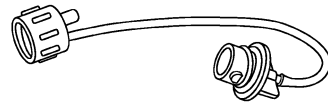
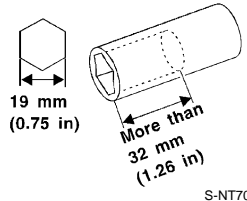
| Tool name<br>(Kent-Moore No.)  | Description  |
|--|--|
| Leak detector<br>i.e.: (J-41416)<br> S-NT703                     | Locates the EVAP leak                                  |
| EVAP service port<br>adapter<br>i.e.: (J-41413-OBD)<br> S-NT704 | Applies positive pressure through EVAP service port    |
| Fuel filler cap adapter<br>i.e.: (MLR-8382)<br> S-NT815         | Checks fuel tank vacuum relief valve opening pressure  |
| Socket wrench<br> S-NT705                                       | Removes and installs engine coolant temperature sensor |

H

I

J

K

L

M

N



O

P

# PREPARATION

< PREPARATION >

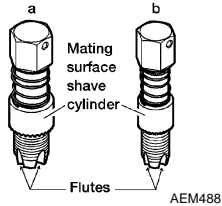
[VQ37VHR FOR MEXICO]

| Tool name<br>(Kent-Moore No.)   | Description   |
|---|---|
| <p>Oxygen sensor thread cleaner<br/>i.e.: (J-43897-18)<br/>(J-43897-12)</p>                                | <p>Reconditions the exhaust system threads before installing a new oxygen sensor. Use with anti-seize lubricant shown below.<br/><b>a: 18 mm diameter with pitch 1.5 mm for Zirconia Oxygen Sensor</b><br/><b>b: 12 mm diameter with pitch 1.25 mm for Titanium Oxygen Sensor</b></p> |
| <p>Anti-seize lubricant<br/>i.e.: (Permatex™ 133AR or equivalent meeting MIL specification MIL-A-907)</p>  | <p>Lubricates oxygen sensor thread cleaning tool when reconditioning exhaust system threads.</p>  |



## SYSTEM DESCRIPTION

### COMPONENT PARTS

#### ENGINE CONTROL SYSTEM

#### ENGINE CONTROL SYSTEM : Component Parts Location

INFOID:000000007729624

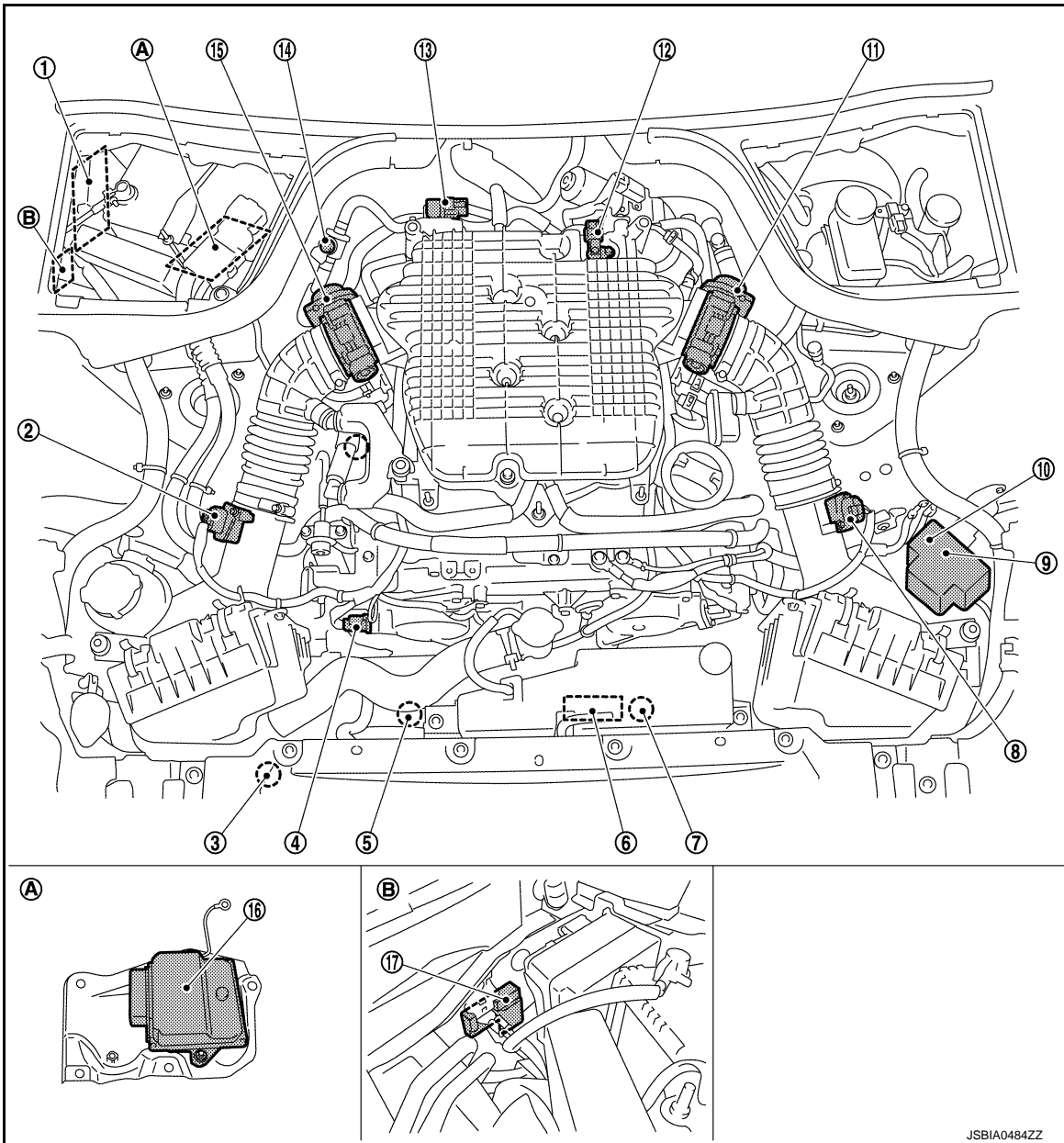

- |   |   |   |
|---|---|---|
| 1. IPDM E/R<br><a href="#">PCS-5, "IPDM E/R : Component Parts Location"</a> | 2. Mass air flow sensor (with intake air temperature sensor) (bank 1) | 3. Refrigerant pressure sensor                  |
| 4. Camshaft position sensor (PHASE) (bank 1)                                | 5. Cooling fan motor-2  | 6. Cooling fan control module                   |
| 7. Cooling fan motor-1  | 8. Mass air flow sensor (bank 2)                                      | 9. VVEL actuator motor relay                    |
| 10. Cooling fan relay   | 11. Electric throttle control actuator (bank 2)                       | 12. Manifold absolute pressure (MAP) sensor     |
| 13. EVAP canister purge volume control solenoid valve                       | 14. EVAP service port   | 15. Electric throttle control actuator (bank 1) |

# COMPONENT PARTS

< SYSTEM DESCRIPTION >

[VQ37VHR FOR MEXICO]

- 16. VVEL control module
- 17. Battery current sensor (with battery temperature sensor)
- A. Under the battery tray (View with upside-down)
- B. Body side in battery case

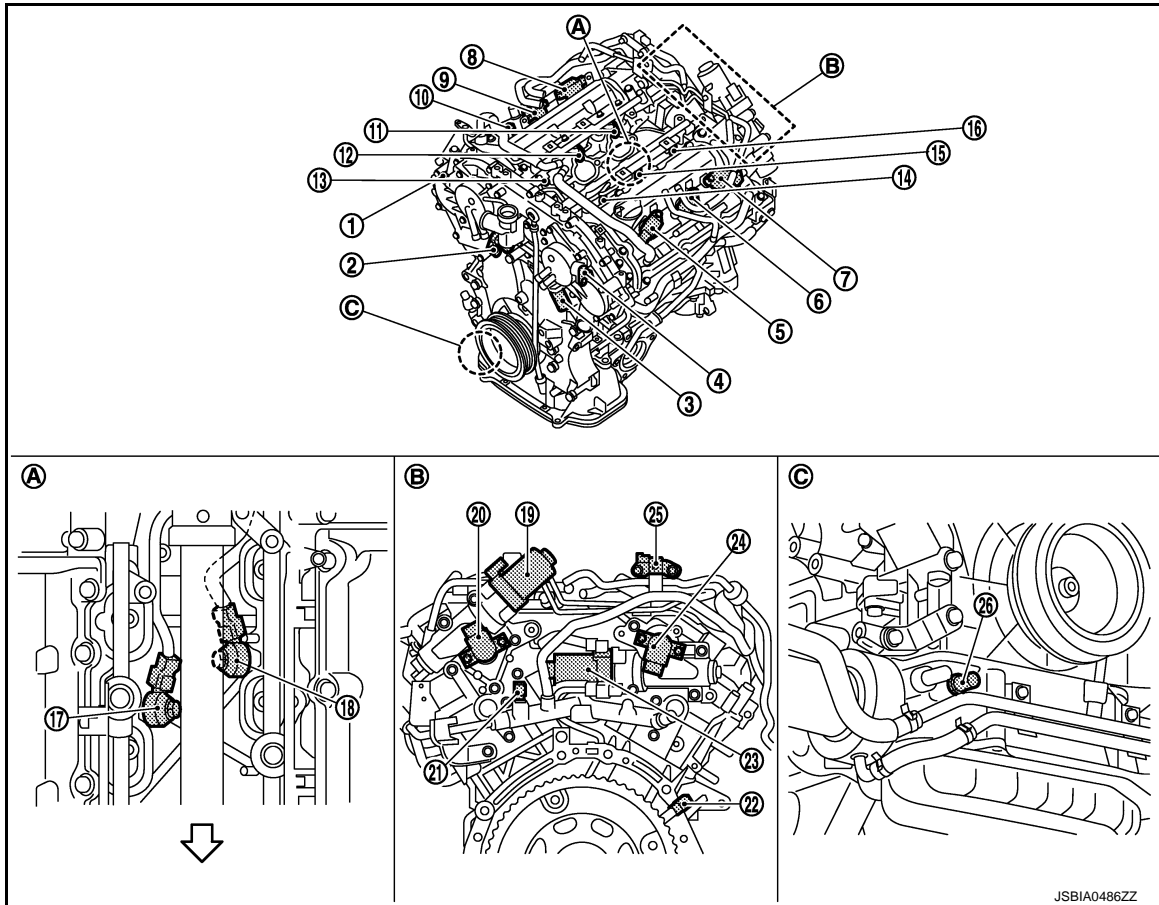

- |  |   |   |
|--|---|---|
| 1. Camshaft position sensor (PHASE) (bank 1)                             | 2. Intake valve timing control solenoid valve (bank 1)                  | 3. Intake valve timing control solenoid valve (bank 2)                  |
| 4. Camshaft position sensor (PHASE) (bank 2)                             | 5. Ignition coil (with power transistor) and spark plug (No.2 cylinder) | 6. Ignition coil (with power transistor) and spark plug (No.4 cylinder) |
| 7. Ignition coil (with power transistor) and spark plug (No.6 cylinder)  | 8. Ignition coil (with power transistor) and spark plug (No.5 cylinder) | 9. Ignition coil (with power transistor) and spark plug (No.3 cylinder) |
| 10. Ignition coil (with power transistor) and spark plug (No.1 cylinder) | 11. Fuel injector (No.5 cylinder)                                       | 12. Fuel injector (No.3 cylinder)                                       |
| 13. Fuel injector (No.1 cylinder)  | 14. Fuel injector (No.2 cylinder)                                       | 15. Fuel injector (No.4 cylinder)                                       |
| 16. Fuel injector (No.6 cylinder)  | 17. Knock sensor (bank 1)   | 18. Knock sensor (bank 2)   |
| 19. VVEL actuator motor (bank 2)   | 20. VVEL control shaft position sensor (bank 2)                         | 21. Engine coolant temperature sensor                                   |
| 22. Crankshaft position sensor (POS)                                     | 23. VVEL actuator motor (bank 1)  | 24. VVEL control shaft position sensor (bank 1)                         |
| 25. EVAP canister purge volume control solenoid valve                    | 26. Engine oil temperature sensor                                       |   |
| A. Top view of the engine (View with intake manifold is removed)         | B. Rear view of the engine  | C. Front view of the engine   |

⇐ Engine front

# COMPONENT PARTS

< SYSTEM DESCRIPTION >

[VQ37VHR FOR MEXICO]

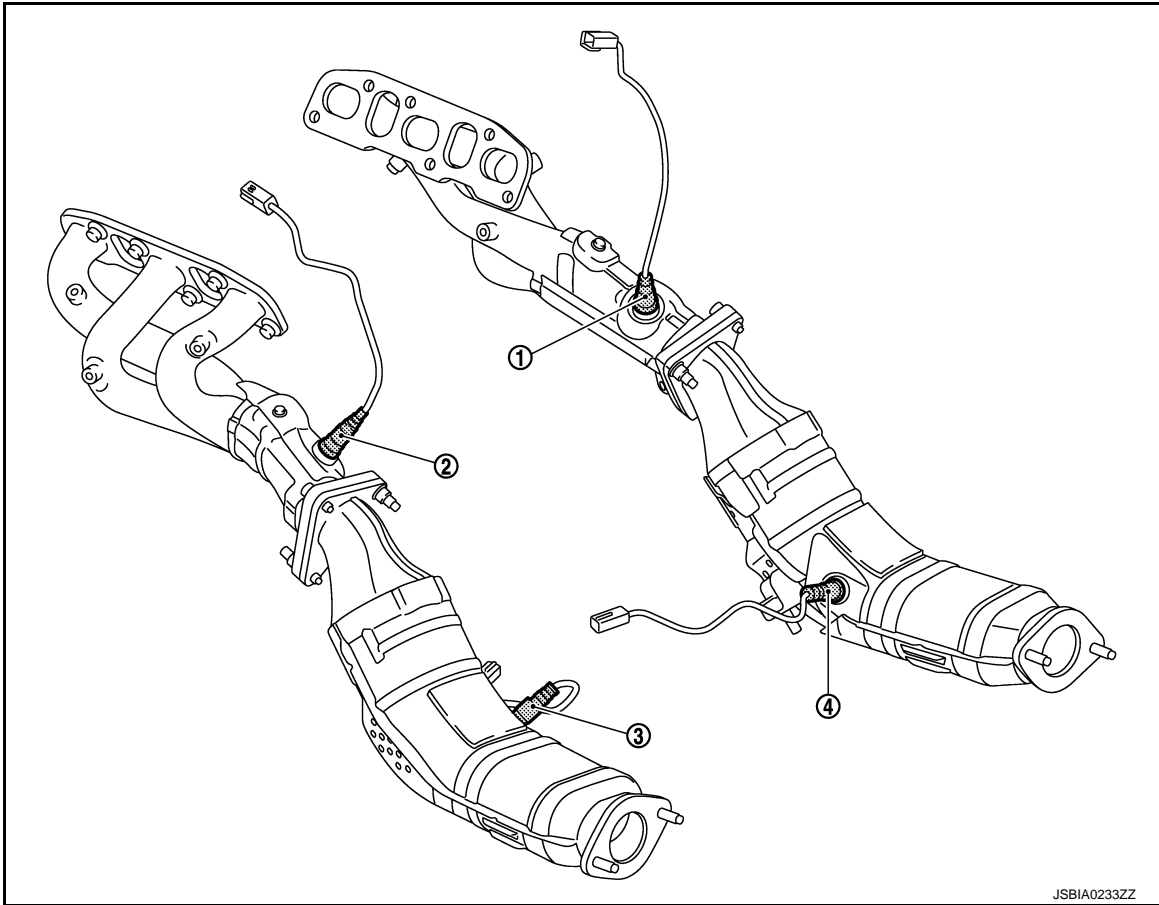

- 1. A/F sensor 1 (bank 1)
- 2. A/F sensor 1 (bank 2)
- 3. Heated oxygen sensor 2 (bank 2)
- 4. Heated oxygen sensor 2 (bank 1)

A

EC

C

D

E

F

G

H

I

J

K

L

M

N

O

P

# COMPONENT PARTS

< SYSTEM DESCRIPTION >

[VQ37VHR FOR MEXICO]

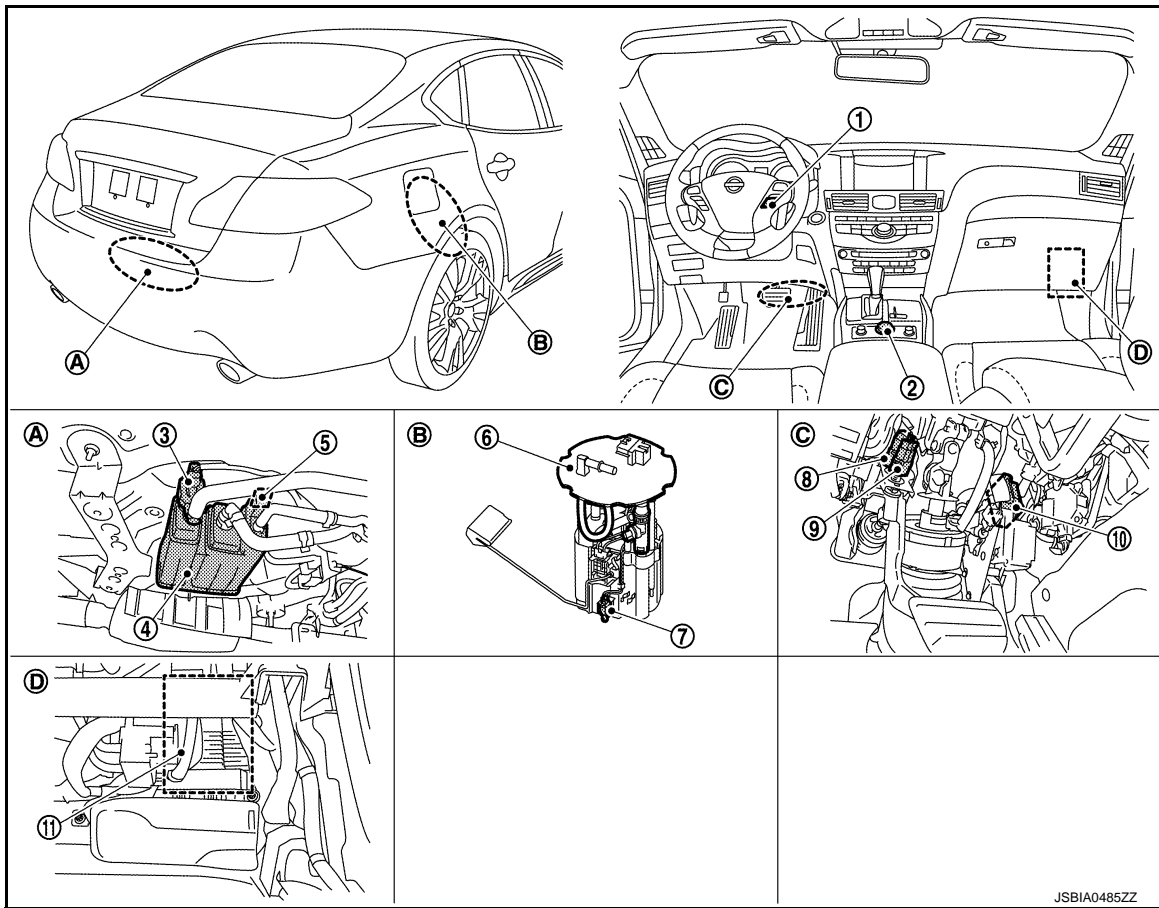

- |                                       |  |   |
|---------------------------------------|--|---|
| 1. ASCD steering switch               | 2. Drive mode select switch            | 3. EVAP canister vent control valve     |
| 4. EVAP canister                      | 5. EVAP control system pressure sensor | 6. Fuel level sensor unit and fuel pump |
| 7. Fuel tank temperature sensor       | 8. Stop lamp switch                    | 9. ASCD brake switch                    |
| 10. Accelerator pedal position sensor | 11. ECM                                |   |
| A. Under the spare tire housing       | B. Rear seat (lower right)             | C. Around the pedal                     |
| D. Lower right of the glove box       |  |   |

## ENGINE CONTROL SYSTEM : Component Description

INFOID:000000007729625

| Component                          | Reference  |
|------------------------------------|--|
| A/F sensor 1                       | <a href="#">EC-559. "Air Fuel Ratio Sensor 1"</a>                                  |
| A/F sensor 1 heater                | <a href="#">EC-559. "Air Fuel Ratio Sensor 1 Heater"</a>                           |
| Accelerator pedal position sensor  | <a href="#">EC-559. "Accelerator Pedal Position Sensor"</a>                        |
| ASCD brake switch                  | <a href="#">EC-894. "Description"</a>  |
| ASCD steering switch               | <a href="#">EC-560. "ASCD Steering Switch"</a>                                     |
| Battery current sensor             | <a href="#">EC-560. "Battery Current Sensor (With Battery Temperature Sensor)"</a> |
| Camshaft position sensor (PHASE)   | <a href="#">EC-561. "Camshaft Position Sensor (PHASE)"</a>                         |
| Cooling fan control module         | <a href="#">EC-561. "Cooling Fan"</a>  |
| Cooling fan motor                  | <a href="#">EC-561. "Cooling Fan"</a>  |
| Crankshaft position sensor (POS)   | <a href="#">EC-561. "Crankshaft Position Sensor (POS)"</a>                         |
| Electric throttle control actuator | <a href="#">EC-562. "Electric Throttle Control Actuator"</a>                       |
| Engine coolant temperature sensor  | <a href="#">EC-562. "Engine Coolant Temperature Sensor"</a>                        |

# COMPONENT PARTS

< SYSTEM DESCRIPTION >

[VQ37VHR FOR MEXICO]

| Component   | Reference   |
|---|---|
| Engine oil temperature sensor                     | <a href="#">EC-563. "Engine Oil Temperature Sensor"</a>                     |
| EVAP canister purge volume control solenoid valve | <a href="#">EC-563. "EVAP Canister Purge Volume Control Solenoid Valve"</a> |
| EVAP canister vent control valve                  | <a href="#">EC-563. "EVAP Canister Vent Control Valve"</a>                  |
| EVAP control system pressure sensor               | <a href="#">EC-564. "EVAP Control System Pressure Sensor"</a>               |
| Fuel injector                                     | <a href="#">EC-564. "Fuel Injector"</a>                                     |
| Fuel level sensor                                 | <a href="#">EC-564. "Fuel Level Sensor"</a>                                 |
| Fuel pump   | <a href="#">EC-564. "Fuel Pump"</a>   |
| Fuel tank temperature sensor                      | <a href="#">EC-565. "Fuel Tank Temperature Sensor"</a>                      |
| Heated oxygen sensor 2                            | <a href="#">EC-565. "Heated Oxygen Sensor 2"</a>                            |
| Heated oxygen sensor 2 heater                     | <a href="#">EC-565. "Heated Oxygen Sensor 2 Heater"</a>                     |
| ICC brake switch                                  | <a href="#">EC-566. "ICC Brake Switch"</a>                                  |
| ICC steering switch                               | <a href="#">EC-566. "ICC Steering Switch"</a>                               |
| Ignition signal                                   | <a href="#">EC-565. "Ignition Coil"</a>                                     |
| Intake air temperature sensor                     | <a href="#">EC-566. "Intake Air Temperature Sensor"</a>                     |
| Intake valve timing control solenoid valve        | <a href="#">EC-566. "Intake Valve Timing Control Solenoid Valve"</a>        |
| Knock sensor                                      | <a href="#">EC-566. "Knock Sensor"</a>                                      |
| Manifold absolute pressure (MAP) sensor           | <a href="#">EC-567. "Manifold Absolute Pressure Sensor"</a>                 |
| Mass air flow sensor                              | <a href="#">EC-567. "Mass Air Flow Sensor"</a>                              |
| PCV valve   | <a href="#">EC-570. "Positive Crankcase Ventilation"</a>                    |
| Power steering pressure sensor                    | <a href="#">EC-567. "Power Steering Pressure Sensor"</a>                    |
| Refrigerant pressure sensor                       | <a href="#">EC-568. "Refrigerant Pressure Sensor"</a>                       |
| Stop lamp switch                                  | <a href="#">EC-560. "Brake Switch"</a>                                      |
| Throttle control motor                            | <a href="#">EC-568. "Throttle Control Motor"</a>                            |
| Throttle control motor relay                      | <a href="#">EC-568. "Throttle Control Motor Relay"</a>                      |
| Throttle position sensor                          | <a href="#">EC-568. "Throttle Position Sensor"</a>                          |
| VVEL actuator motor                               | <a href="#">EC-568. "VVEL Actuator Motor"</a>                               |
| VVEL actuator motor relay                         | <a href="#">EC-568. "VVEL Actuator Motor Relay"</a>                         |
| VVEL control module                               | <a href="#">EC-569. "VVEL Control Module"</a>                               |
| VVEL control shaft position sensor                | <a href="#">EC-569. "VVEL Control Position Sensor"</a>                      |

Infiniti Drive Mode Selector

A  
EC  
C  
D  
E  
F  
G  
H  
I  
J  
K  
L  
M  
N  
O  
P

# COMPONENT PARTS

< SYSTEM DESCRIPTION >

[VQ37VHR FOR MEXICO]

## Infiniti Drive Mode Selector : Component Parts Location

INFOID:000000007729626

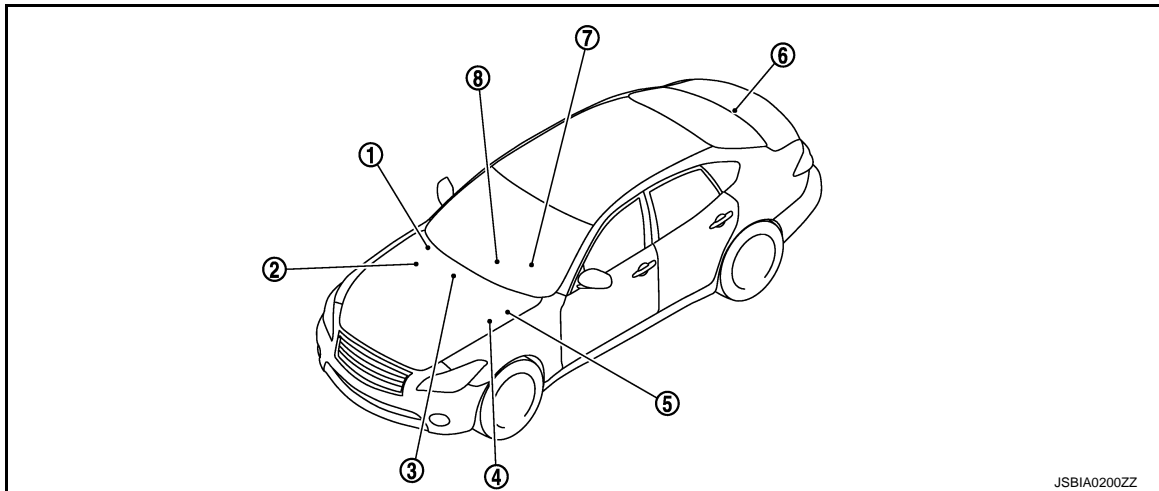

1. A/C auto amp.  
Refer to [HAC-7, "AUTOMATIC AIR CONDITIONING SYSTEM \(WITH FOREST AIR\) : Component Parts Location"](#) (WITH FOREST AIR).  
Refer to [HAC-10, "AUTOMATIC AIR CONDITIONING SYSTEM \(WITHOUT FOREST AIR\) : Component Parts Location"](#) (WITHOUT FOREST AIR).
2. ECM  
Refer to [EC-553, "ENGINE CONTROL SYSTEM : Component Parts Location"](#).
3. AV control unit  
Refer to [AV-10, "Component Parts Location"](#) (BASE AUDIO WITHOUT NAVIGATION).  
Refer to [AV-127, "Component Parts Location"](#) (BOSE AUDIO WITH NAVIGATION).
4. Accelerator pedal actuator
5. Combination meter  
(Vehicle information display, and ECO drive indicator)
6. ADAS control unit  
[DAS-14, "Component Parts Location"](#).
7. TCM  
[TM-10, "A/T CONTROL SYSTEM : Component Parts Location"](#).
8. Drive mode select switch

## Infiniti Drive Mode Selector : Component Description

INFOID:000000007729627

| Part name                | Description   |
|--------------------------|---|
| Drive mode select switch | Transmits an ON/OFF state signal of STANDARD, SPORT, ECO, or SNOW mode to the A/C auto amp.   |
| A/C auto amp.            | Transmits an input signal (ON/OFF state of each mode) received from the drive mode select switch to the TCM, combination meter, 4WAS main control unit, and ADAS control unit via CAN communication.  |
| TCM                      | Transmits a state of a mode received from the A/C auto amp. to ECM.   |
| ECM                      | <ul style="list-style-type: none"> <li>• Receives a ECO mode signal from TCM and controls throttle angle characteristics and torque.</li> <li>• Controls the ECO drive indicator when in ECO mode. The ECO drive indicator turns according to accelerator pedal operation.</li> </ul> |
| Combination meter        | <ul style="list-style-type: none"> <li>• Indicates a mode state on the vehicle information display, based on a mode state signal received from the A/C auto amp.</li> <li>• Turns ON the ECO drive indicator according to a request from ECM when in ECO mode.</li> </ul>             |

Accelerator Pedal Position Sensor

INFOID:000000007729628

The accelerator pedal position sensor is installed on the upper end of the accelerator pedal assembly. The sensor detects the accelerator position and sends a signal to the ECM.

Accelerator pedal position sensor has two sensors. These sensors are a kind of potentiometer which transform the accelerator pedal position into output voltage, and emit the voltage signal to the ECM. The ECM judges the current opening angle of the accelerator pedal from these signals and controls the throttle control motor based on these signals.

Idle position of the accelerator pedal is determined by the ECM receiving the signal from the accelerator pedal position sensor. The ECM uses this signal for engine operations such as fuel cut.

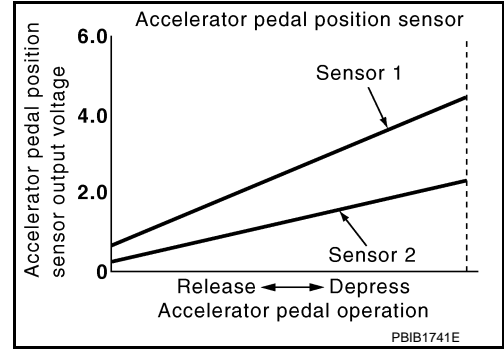

Air Fuel Ratio Sensor 1

INFOID:000000007729629

The air fuel ratio (A/F) sensor 1 is a planar one-cell limit current sensor. The sensor element of the A/F sensor 1 is composed an electrode layer, which transports ions. It has a heater in the element.

The sensor is capable of precise measurement  $\lambda = 1$ , but also in the lean and rich range. Together with its control electronics, the sensor outputs a clear, continuous signal throughout a wide  $\lambda$  range.

The exhaust gas components diffuse through the diffusion layer at the sensor cell. An electrode layer is applied voltage, and this current relative oxygen density in lean. Also this current relative hydrocarbon density in rich.

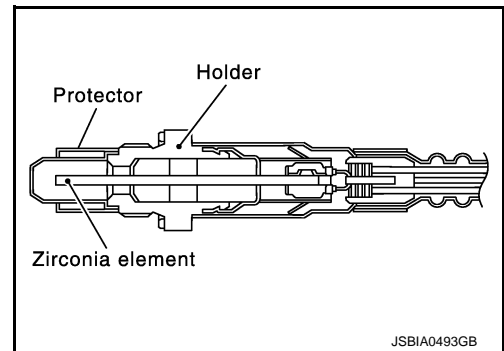

Therefore, the A/F sensor 1 is able to indicate air fuel ratio by this electrode layer of current. In addition, a heater is integrated in the sensor to ensure the required operating temperature of about 800°C (1,472°F).

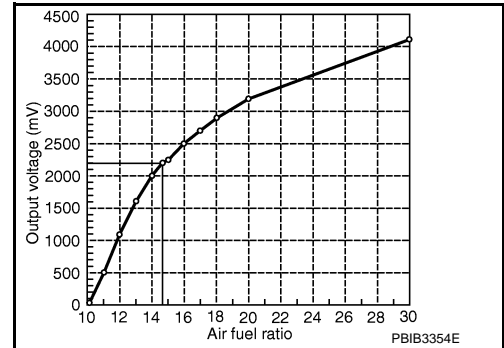

Air Fuel Ratio Sensor 1 Heater

INFOID:000000007729630

SYSTEM DESCRIPTION

| Sensor   | Input Signal to ECM  | ECM function                                    | Actuator                                |
|--|----------------------|---|---|
| Camshaft position sensor (PHASE)<br>Crankshaft position sensor (POS) | Engine speed         | Air fuel ratio (A/F) sensor 1<br>heater control | Air fuel ratio (A/F) sensor 1<br>heater |
| Mass air flow sensor   | Amount of intake air |   |   |

The ECM performs ON/OFF duty control of the A/F sensor 1 heater corresponding to the engine operating condition to keep the temperature of A/F sensor 1 element at the specified range.

ASCD Brake Switch

INFOID:000000007729631

When the brake pedal is depressed, ASCD brake switch is turned OFF and stop lamp switch is turned ON. ECM detects the state of the brake pedal by those two types of input (ON/OFF signal).

Refer to [EC-578. "AUTOMATIC SPEED CONTROL DEVICE \(ASCD\) : System Description"](#) for the ASCD function.

## ASCD Indicator

INFOID:000000007729632

ASCD operation status is indicated by two indicators (CRUISE and SET) and CRUISE lamp in combination meter.

CRUISE indicator is displayed to indicate that ASCD system is ready for operation when MAIN switch on ASCD steering switch is turned ON.

SET indicator is displayed when the following conditions are met.

- CRUISE indicator is displayed.
- SET/COAST switch on ASCD steering switch is turned ON while vehicle speed is within the range of the ASCD setting.

SET indicator is displayed during ASCD control.

Refer to [EC-578. "AUTOMATIC SPEED CONTROL DEVICE \(ASCD\) : System Description"](#) for the ASCD function.

## ASCD Steering Switch

INFOID:000000007729633

ASCD steering switch has variant values of electrical resistance for each button. ECM reads voltage variation of switch, and determines which button is operated.

Refer to [EC-578. "AUTOMATIC SPEED CONTROL DEVICE \(ASCD\) : System Description"](#) for the ASCD function.

## Battery Current Sensor (With Battery Temperature Sensor)

INFOID:000000007729634

### OUTLINE

The power generation voltage variable control enables fuel consumption to be decreased by reducing the engine load which is caused by the power generation of the generator.

Based on sensor signals, ECM judges whether or not the power generation voltage variable control is performed. When performing the power generation voltage variable control, ECM calculates the target power generation voltage based on the sensor signal. And ECM sends the calculated value as the power generation command value to IPDM E/R. For the details of the power generation voltage variable control, refer to [CHG-8. "POWER GENERATION VOLTAGE VARIABLE CONTROL SYSTEM : System Description"](#).

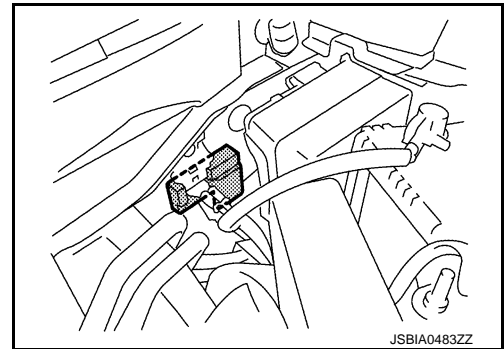

### CAUTION:

**Never connect the electrical component or the ground wire directly to the battery terminal. The connection causes the malfunction of the power generation voltage variable control, and then the battery discharge may occur.**

### BATTERY CURRENT SENSOR

The battery current sensor is installed to the battery negative cable. The sensor measures the charging/discharging current of the battery.

### BATTERY TEMPERATURE SENSOR

Battery temperature sensor is integrated in battery current sensor. The sensor measures temperature around the battery. The electrical resistance of the thermistor decreases as temperature increases.

#### <Reference data>

| Temperature [°C (°F)] | Voltage* (V) | Resistance (kΩ) |
|-----------------------|--------------|-----------------|
| 25 (77)               | 3.333        | 1.9 - 2.1       |
| 90 (194)              | 0.969        | 0.222 - 0.258   |

\*: These data are reference values and are measured between battery temperature sensor signal terminal and sensor ground.

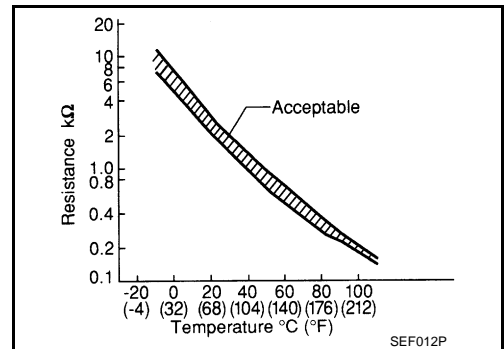

## Brake Switch

INFOID:000000007729635

Brake switch signal is applied to the ECM through the stop lamp switch when the brake pedal is depressed. This signal is used mainly to decrease the engine speed when the vehicle is being driven.



## Camshaft Position Sensor (PHASE)

INFOID:000000007729636

The camshaft position sensor (PHASE) senses the retraction of camshaft (INT) to identify a particular cylinder. The camshaft position sensor (PHASE) senses the piston position.

When the crankshaft position sensor (POS) system becomes inoperative, the camshaft position sensor (PHASE) provides various controls of engine parts instead, utilizing timing of cylinder identification signals.

The sensor consists of a permanent magnet and Hall IC.

When engine is running, the high and low parts of the teeth cause the gap with the sensor to change.

The changing gap causes the magnetic field near the sensor to change.

Due to the changing magnetic field, the voltage from the sensor changes.

ECM receives the signals as shown in the figure.

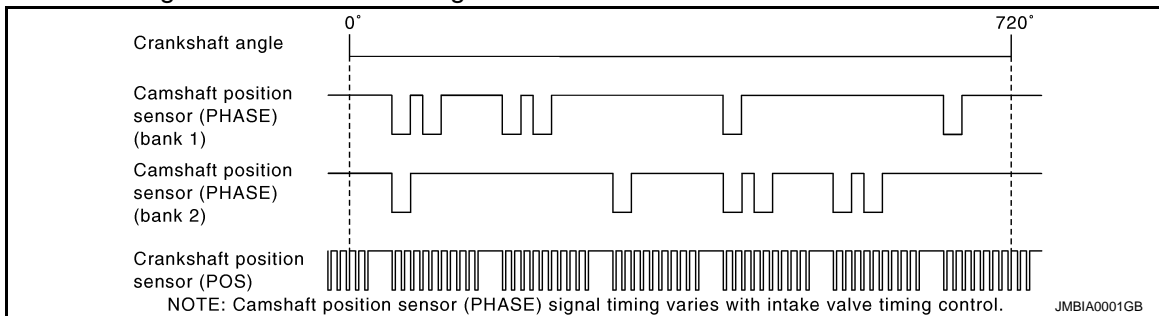
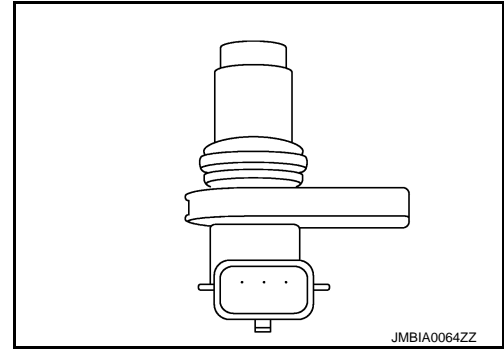

## Cooling Fan

INFOID:000000007729637

### COOLING FAN CONTROL MODULE

Cooling fan control module receives ON/OFF pulse duty signal from IPDM E/R. Corresponding to this ON/OFF pulse duty signal, cooling fan control module sends cooling fan motor operating voltage to cooling fan motor. The revolution speed of cooling fan motor is controlled by duty cycle of the voltage.

### COOLING FAN MOTOR

Cooling fan motor receives cooling fan motor operating voltage from cooling fan control module. The revolution speed of cooling fan motor is controlled by duty cycle of the voltage.

## Crankshaft Position Sensor (POS)

INFOID:000000007729638

The crankshaft position sensor (POS) is located on the cylinder block facing the gear teeth (cogs) of the signal plate. It detects the fluctuation of the engine revolution.

The sensor consists of a permanent magnet and Hall IC.

When the engine is running, the high and low parts of the teeth cause the gap with the sensor to change.

The changing gap causes the magnetic field near the sensor to change.

Due to the changing magnetic field, the voltage from the sensor changes.

The ECM receives the voltage signal and detects the fluctuation of the engine revolution.

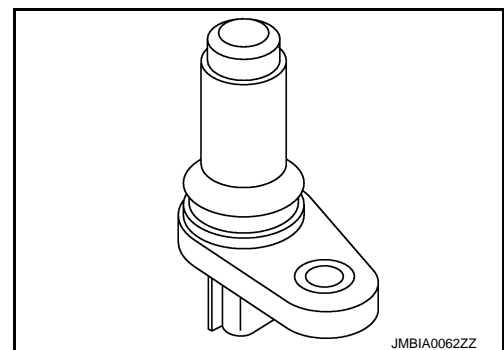

# COMPONENT PARTS

< SYSTEM DESCRIPTION >

[VQ37VHR FOR MEXICO]

ECM receives the signals as shown in the figure.

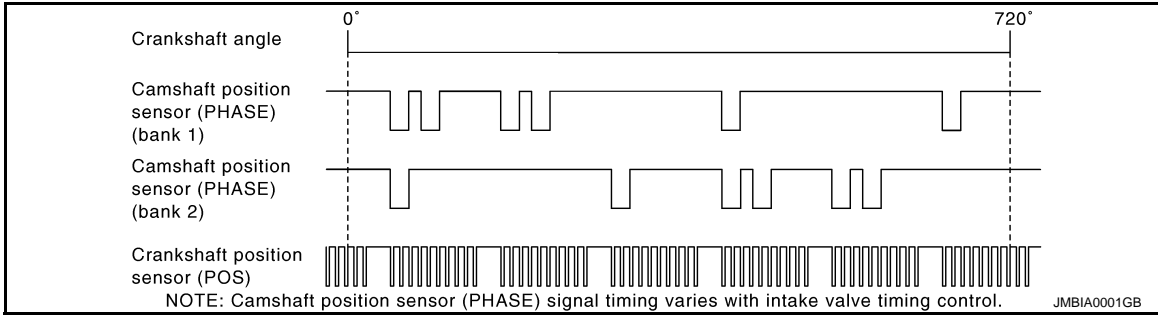

## ECM

INFOID:000000007729639

The ECM consists of a microcomputer and connectors for signal input and output and for power supply. The ECM controls the engine.

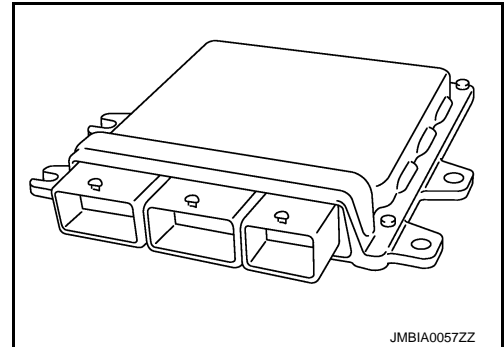

## Electric Throttle Control Actuator

INFOID:000000007729640

Electric throttle control actuator consists of throttle control motor, throttle position sensor, etc. The throttle control motor is operated by the ECM and it opens and closes the throttle valve. The throttle position sensor detects the throttle valve position and feeds the voltage signals to the ECM. The ECM judges the current opening angle of the throttle valve from these signals and controls the throttle valve opening angle properly in response to driving condition via the throttle control motor.

## Engine Coolant Temperature Sensor

INFOID:000000007729641

The engine coolant temperature sensor is used to detect the engine coolant temperature. The sensor modifies a voltage signal from the ECM. The modified signal returns to the ECM as the engine coolant temperature input. The sensor uses a thermistor which is sensitive to the change in temperature. The electrical resistance of the thermistor decreases as temperature increases.

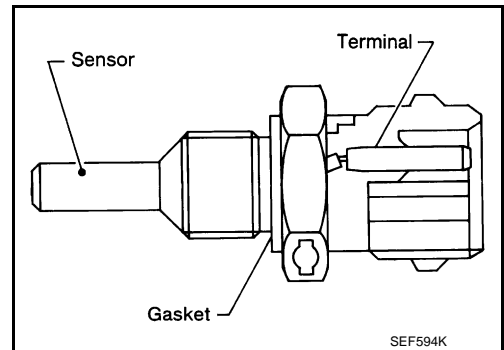

### <Reference data>

| Engine coolant temperature [°C (°F)] | Voltage* (V) | Resistance (kΩ) |
|--------------------------------------|--------------|-----------------|
| -10 (14)                             | 4.4          | 7.0 - 11.4      |
| 20 (68)                              | 3.5          | 2.10 - 2.90     |
| 50 (122)                             | 2.2          | 0.68 - 1.00     |
| 90 (194)                             | 0.9          | 0.236 - 0.260   |

\*: These data are reference values and are measured between ECM terminals 71 (Engine coolant temperature sensor) and 84 (Sensor ground).

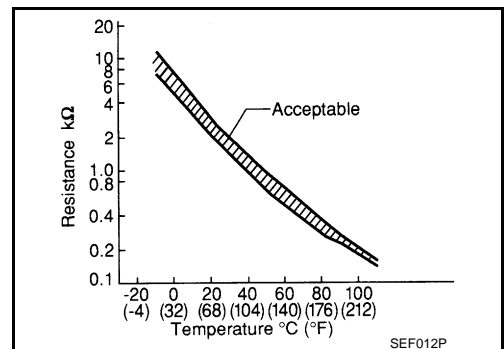

## Engine Oil Temperature Sensor

INFOID:000000007729642

The engine oil temperature sensor is used to detect the engine oil temperature. The sensor modifies a voltage signal from the ECM. The modified signal returns to the ECM as the engine oil temperature input. The sensor uses a thermistor which is sensitive to the change in temperature. The electrical resistance of the thermistor decreases as temperature increases.

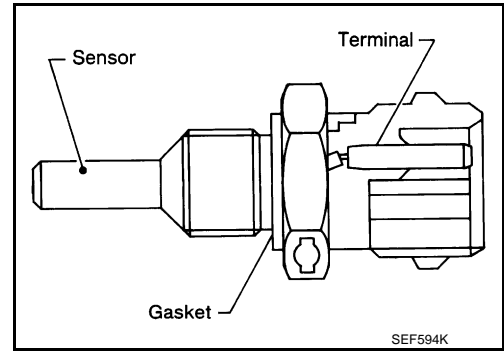

### <Reference data>

| Engine oil temperature [°C (°F)] | Voltage* (V) | Resistance (kΩ) |
|----------------------------------|--------------|-----------------|
| -10 (14)                         | 4.4          | 7.0 - 11.4      |
| 20 (68)                          | 3.5          | 2.10 - 2.90     |
| 50 (122)                         | 2.2          | 0.68 - 1.00     |
| 90 (194)                         | 0.9          | 0.236 - 0.260   |
| 110 (230)                        | 0.6          | 0.143 - 0.153   |

\*: These data are reference values and are measured between ECM terminals 78 (Engine oil temperature sensor) and 84 (Sensor ground).

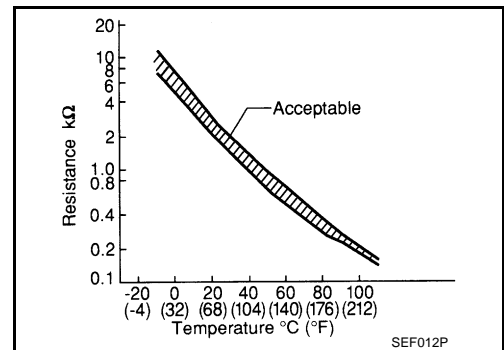

## EVAP Canister Purge Volume Control Solenoid Valve

INFOID:0000000007729643

The EVAP canister purge volume control solenoid valve is used to control the flow rate of fuel vapor from the EVAP canister. The EVAP canister purge volume control solenoid valve is moved by ON/OFF pulses from the ECM. The longer the ON pulse, the greater the amount of fuel vapor that will flow through the valve.

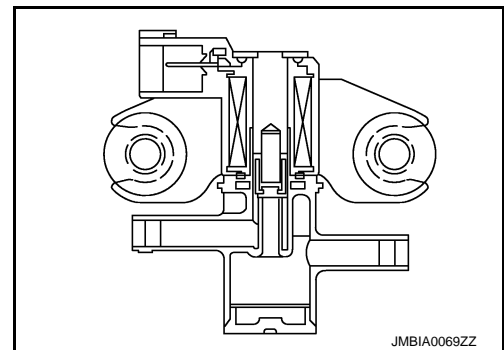

## EVAP Canister Vent Control Valve

INFOID:0000000007729644

The EVAP canister vent control valve is located on the EVAP canister and is used to seal the canister vent.

This solenoid valve responds to signals from the ECM. When the ECM sends an ON signal, the coil in the solenoid valve is energized. A plunger will then move to seal the canister vent. The ability to seal the vent is necessary for the on board diagnosis of other evaporative emission control system components.

This solenoid valve is used only for diagnosis, and usually remains opened.

When the vent is closed, under normal purge conditions, the evaporative emission control system is depressurized and allows "EVAP Control System" diagnosis.

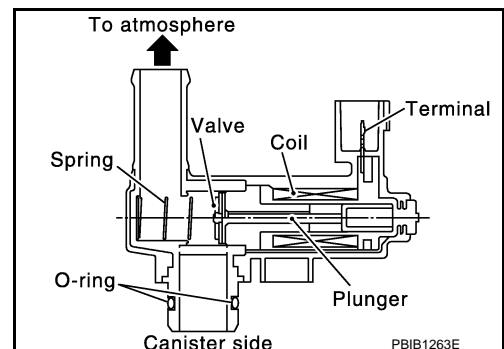

# COMPONENT PARTS

< SYSTEM DESCRIPTION >

[VQ37VHR FOR MEXICO]

## EVAP Control System Pressure Sensor

INFOID:000000007729646

The EVAP control system pressure sensor detects pressure in the purge line. The sensor output voltage to the ECM increases as pressure increases.

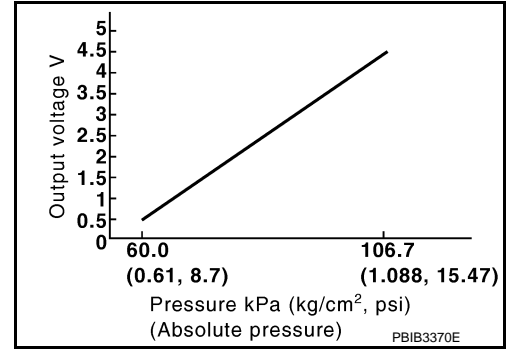

## Fuel Injector

INFOID:000000007729646

The fuel injector is a small, precise solenoid valve. When the ECM supplies a ground to the fuel injector circuit, the coil in the fuel injector is energized. The energized coil pulls the ball valve back and allows fuel to flow through the fuel injector into the intake manifold. The amount of fuel injected depends upon the injection pulse duration. Pulse duration is the length of time the fuel injector remains open. The ECM controls the injection pulse duration based on engine fuel needs.

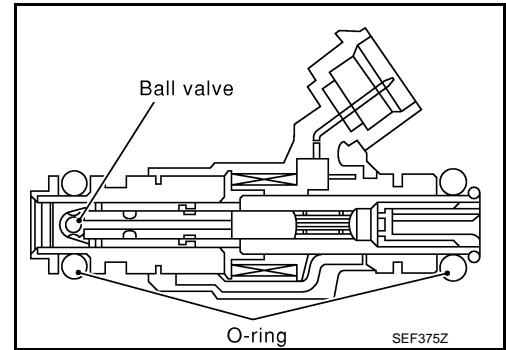

## Fuel Level Sensor

INFOID:000000007729647

The fuel level sensor is mounted in the fuel level sensor unit. The sensor detects a fuel level in the fuel tank and transmits a signal to the "A/C auto amp.". The "A/C auto amp." sends the fuel level sensor signal to the ECM via the CAN communication line. It consists of two parts, one is mechanical float and the other is variable resistor. Fuel level sensor output voltage changes depending on the movement of the fuel mechanical float.

## Fuel Pump

INFOID:000000007729648

| Sensor   | Input signal to ECM | ECM Function      | Actuator        |
|--|---------------------|-------------------|-----------------|
| Crankshaft position sensor (POS)<br>Camshaft position sensor (PHASE) | Engine speed*       | Fuel pump control | Fuel pump relay |
| Battery  | Battery voltage*    |                   | ↓<br>Fuel pump  |

\*: ECM determines the start signal status by the signals of engine speed and battery voltage.

The ECM activates the fuel pump for several seconds after the ignition switch is turned ON to improve engine startability. If the ECM receives a engine speed signal from the camshaft position sensor (PHASE), it knows that the engine is rotating, and causes the pump to operate. If the engine speed signal is not received when the ignition switch is ON, the engine stalls. The ECM stops pump operation and prevents battery discharging, thereby improving safety. The ECM does not directly drive the fuel pump. It controls the ON/OFF fuel pump relay, which in turn controls the fuel pump.

| Condition                        | Fuel pump operation    |
|----------------------------------|------------------------|
| Ignition switch is turned to ON. | Operates for 1 second. |
| Engine running and cranking      | Operates.              |
| When engine is stopped           | Stops in 1.5 seconds.  |
| Except as shown above            | Stops.                 |

# COMPONENT PARTS

< SYSTEM DESCRIPTION >

[VQ37VHR FOR MEXICO]

## Fuel Tank Temperature Sensor

INFOID:000000007729649

The fuel tank temperature sensor is used to detect the fuel temperature inside the fuel tank. The sensor modifies a voltage signal from the ECM. The modified signal returns to the ECM as the fuel temperature input. The sensor uses a thermistor which is sensitive to the change in temperature. The electrical resistance of the thermistor decreases as temperature increases.

### <Reference data>

| Fluid temperature [°C (°F)] | Voltage* (V) | Resistance (kΩ) |
|-----------------------------|--------------|-----------------|
| 20 (68)                     | 3.5          | 2.3 - 2.7       |
| 50 (122)                    | 2.2          | 0.79 - 0.90     |

\*: These data are reference values and are measured between ECM terminals 106 (Fuel tank temperature sensor) and 128 (ECM ground).

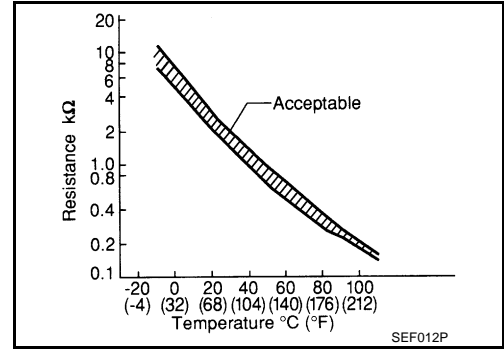

## Heated Oxygen Sensor 2

INFOID:000000007729650

The heated oxygen sensor 2, after three way catalyst 1, monitors the oxygen level in the exhaust gas on each bank.

Even if switching characteristics of the air fuel ratio (A/F) sensor 1 are shifted, the air-fuel ratio is controlled to stoichiometric, by the signal from the heated oxygen sensor 2.

This sensor is made of ceramic zirconia. The zirconia generates voltage from approximately 1 V in richer conditions to 0 V in leaner conditions.

Under normal conditions the heated oxygen sensor 2 is not used for engine control operation.

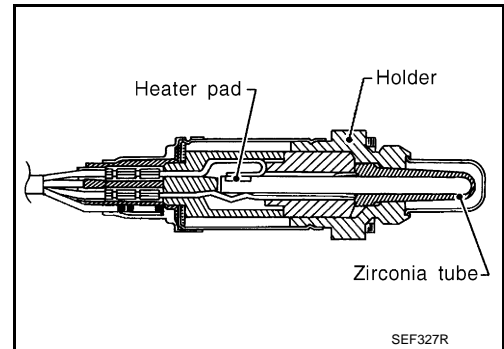

## Heated Oxygen Sensor 2 Heater

INFOID:000000007729651

### SYSTEM DESCRIPTION

| Sensor   | Input signal to ECM        | ECM function                             | Actuator                      |
|--|----------------------------|--|-------------------------------|
| Camshaft position sensor (PHASE)<br>Crankshaft position sensor (POS) | Engine speed               | Heated oxygen sensor 2<br>heater control | Heated oxygen sensor 2 heater |
| Engine coolant temperature sensor                                    | Engine coolant temperature |  |                               |
| Mass air flow sensor   | Amount of intake air       |  |                               |

The ECM performs ON/OFF control of the heated oxygen sensor 2 heater corresponding to the engine speed, amount of intake air and engine coolant temperature.

### OPERATION

| Engine speed rpm   | Heated oxygen sensor 2 heater |
|--|-------------------------------|
| Above 3,600  | OFF                           |
| Below 3,600 rpm after the following conditions are met. <ul style="list-style-type: none"> <li>Engine: After warming up</li> <li>Keeping the engine speed between 3,500 and 4,000 rpm for 1 minute and at idle for 1 minute under no load</li> </ul> | ON                            |

## Ignition Coil

INFOID:000000007729652

The ignition signal from the ECM is sent to and amplified by the power transistor. The power transistor turns ON and OFF the ignition coil primary circuit. This ON/OFF operation induces the proper high voltage in the coil secondary circuit.

## Intake Air Temperature Sensor

INFOID:000000007729653

The intake air temperature sensor is built-into the mass air flow sensor (1). The sensor detects intake air temperature and transmits a signal to the ECM.

The temperature sensing unit uses a thermistor which is sensitive to the change in temperature. Electrical resistance of the thermistor decreases in response to the rise in temperature.

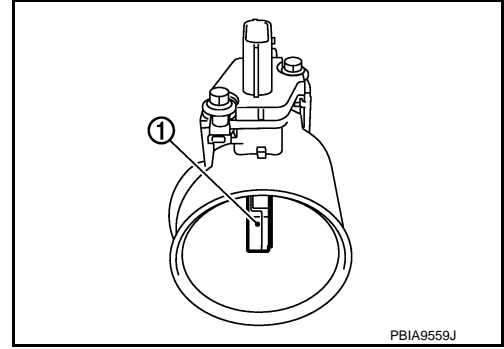

### <Reference data>

| Intake air temperature [°C (°F)] | Voltage* (V) | Resistance (kΩ) |
|----------------------------------|--------------|-----------------|
| 25 (77)                          | 3.3          | 1.800 - 2.200   |
| 80 (176)                         | 1.2          | 0.283 - 0.359   |

\*: These data are reference values and are measured between ECM terminals 67 (Intake air temperature sensor) and 68 (Sensor ground).

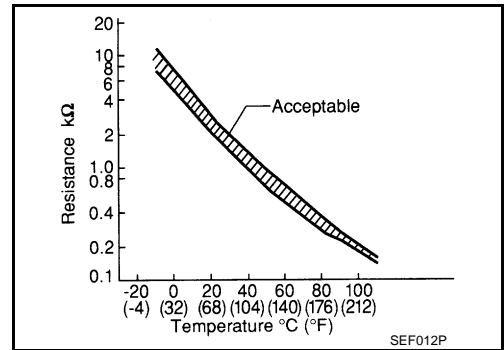

## Intake Valve Timing Control Solenoid Valve

INFOID:000000007729654

Intake valve timing control solenoid valve is activated by ON/OFF pulse duty (ratio) signals from the ECM.

The intake valve timing control solenoid valve changes the oil amount and direction of flow through intake valve timing control unit or stops oil flow.

The longer pulse width advances valve angle.

The shorter pulse width retards valve angle.

When ON and OFF pulse widths become equal, the solenoid valve stops oil pressure flow to fix the intake valve angle at the control position.

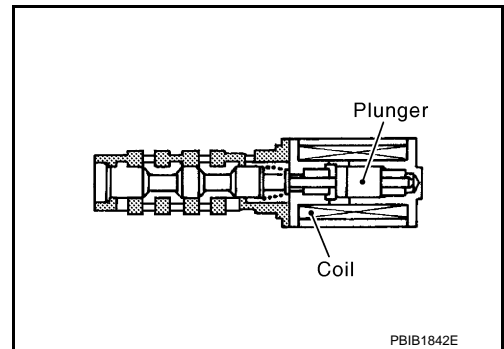

## ICC Brake Switch

INFOID:000000007729655

When the brake pedal is depressed, ICC brake switch is turned OFF and stop lamp switch is turned ON. ECM detects the state of the brake pedal by those two types of input (ON/OFF signal).

Refer to [CCS-13. "System Description"](#) for the ICC function.

## ICC Steering Switch

INFOID:000000007729656

ICC steering switch has variant values of electrical resistance for each button. ECM reads voltage variation of switch, and determines which button is operated.

Refer to [CCS-13. "System Description"](#) for the ICC function.

## Knock Sensor

INFOID:000000007729657

The knock sensor is attached to the cylinder block. It senses engine knocking using a piezoelectric element. A knocking vibration from the cylinder block is sensed as vibrational pressure. This pressure is converted into a voltage signal and sent to the ECM.

## Manifold Absolute Pressure Sensor

INFOID:000000007729658

The manifold absolute pressure (MAP) sensor is placed at intake manifold collector. It detects intake manifold pressure and sends the voltage signal to the ECM.

The sensor uses a silicon diaphragm which is sensitive to the change in pressure. As the pressure increases, the voltage rises.

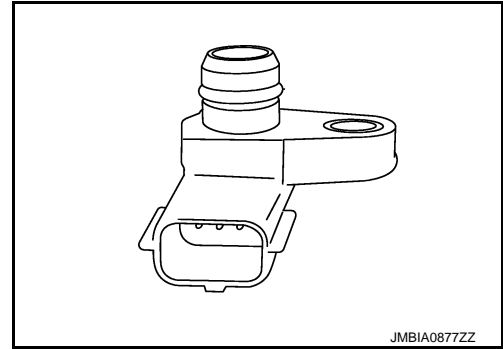

## Malfunction Indicator Lamp

INFOID:000000007729659

The Malfunction Indicator Lamp (MIL) is located on the combination meter.

The MIL will illuminate when the ignition switch is turned ON without the engine running. This is a bulb check.

When the engine is started, the MIL should turn off. If the MIL remains illuminated, the on board diagnostic system has detected an engine system malfunction.

For details, refer to [EC-590, "Diagnosis Description"](#).

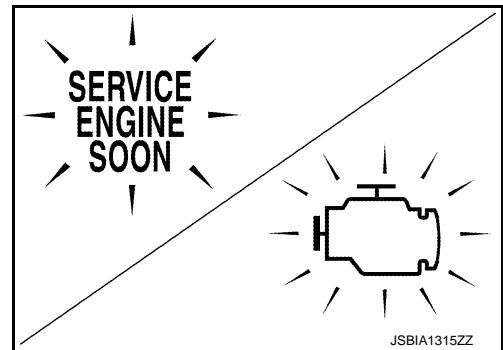

## Mass Air Flow Sensor

INFOID:000000007729660

The mass air flow sensor (1) is placed in the stream of intake air. It measures the intake flow rate by measuring a part of the entire intake flow. The mass air flow sensor controls the temperature of the hot wire to a certain amount. The heat generated by the hot wire is reduced as the intake air flows around it. The greater air flow, the greater the heat loss.

Therefore, the electric current supplied to hot wire is changed to maintain the temperature of the hot wire as air flow increases. The ECM detects the air flow by means of this current change.

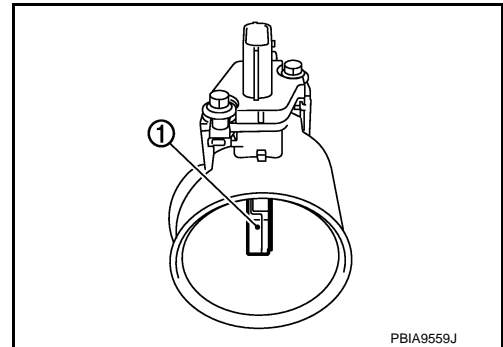

## Power Steering Pressure Sensor

INFOID:000000007729661

Power steering pressure (PSP) sensor is installed to the power steering high-pressure tube and detects a power steering load.

This sensor is a potentiometer which transforms the power steering load into output voltage, and emits the voltage signal to the ECM. The ECM controls the electric throttle control actuator and adjusts the throttle valve opening angle to increase the engine speed and adjusts the idle speed for the increased load.

## Refrigerant Pressure Sensor

INFOID:000000007729662

The refrigerant pressure sensor is installed at the condenser of the air conditioner system. The sensor uses an electrostatic volume pressure transducer to convert refrigerant pressure to voltage. The voltage signal is sent to ECM, and ECM controls cooling fan system.

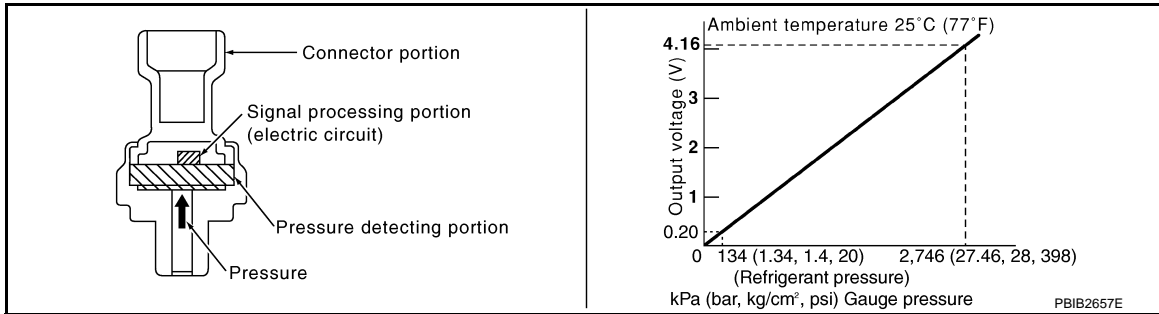

## Throttle Control Motor

INFOID:000000007729663

The throttle control motor is operated by the ECM and it opens and closes the throttle valve. The current opening angle of the throttle valve is detected by the throttle position sensor and it provides feedback to the ECM to control the throttle control motor to make the throttle valve opening angle properly in response to driving condition.

## Throttle Control Motor Relay

INFOID:000000007729664

Power supply for the throttle control motor is provided to the ECM via throttle control motor relay. The throttle control motor relay is ON/OFF controlled by the ECM. When the ignition switch is turned ON, the ECM sends an ON signal to throttle control motor relay and battery voltage is provided to the ECM. When the ignition switch is turned OFF, the ECM sends an OFF signal to throttle control motor relay and battery voltage is not provided to the ECM.

## Throttle Position Sensor

INFOID:000000007729665

Electric throttle control actuator consists of throttle control motor, throttle position sensor, etc. The throttle position sensor responds to the throttle valve movement.

The throttle position sensor has two sensors. These sensors are a kind of potentiometer which transform the throttle valve position into output voltage, and emit the voltage signals to the ECM. The ECM judges the current opening angle of the throttle valve from these signals and controls the throttle valve opening angle properly in response to driving condition via the throttle control motor.

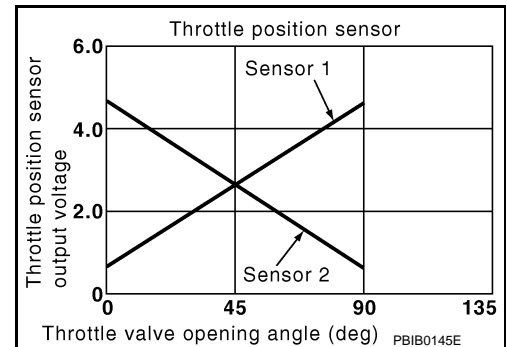

## VVEL Actuator Motor

INFOID:000000007729666

The VVEL actuator motor rotates the control shaft according to the control signal from the VVEL control module. The VVEL control module judges whether the VVEL actuator motor controls the angle properly by the VVEL control shaft position sensor signal.

## VVEL Actuator Motor Relay

INFOID:000000007729667

Power supply for the VVEL actuator motor is provided to the VVEL control module via VVEL actuator motor relay. VVEL actuator motor relay is ON/OFF controlled by the VVEL control module. In addition, when the VVEL actuator motor relay cannot be controlled by the VVEL control module for some reason, it ON/OFF controlled by ECM.



VVEL Control Module

INFOID:000000007729668

The VVEL control module consists of a microcomputer and connectors for signal input and output and for power supply. The VVEL control module controls VVEL system.

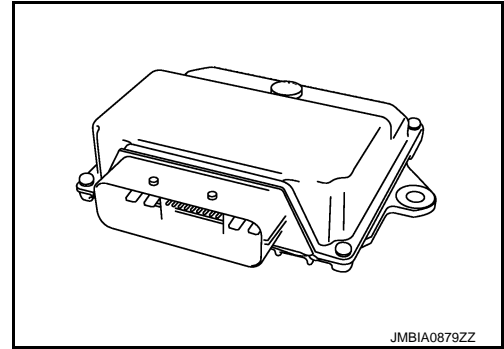

VVEL Control Position Sensor

INFOID:000000007729669

VVEL control shaft position sensor (1) is placed on VVEL actuator sub assembly and detects the control shaft position angle. A magnet is pressed into the arm on the edge of control shaft. The magnetic field changes as the magnet rotates together with the arm resulting in the output voltage change of the sensor. VVEL control module detects the actual position angle through the voltage change and sends the signal to ECM.

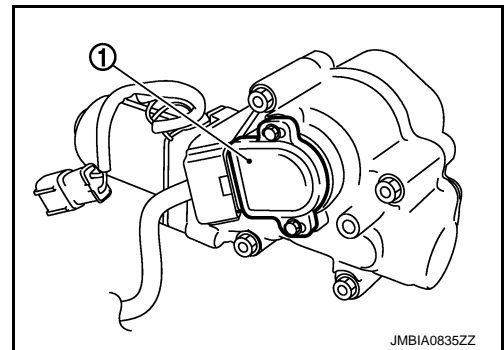

A  
EC  
C  
D  
E  
F  
G  
H  
I  
J  
K  
L  
M  
N  
O  
P

## STRUCTURE AND OPERATION

### Positive Crankcase Ventilation

INFOID:000000007729670

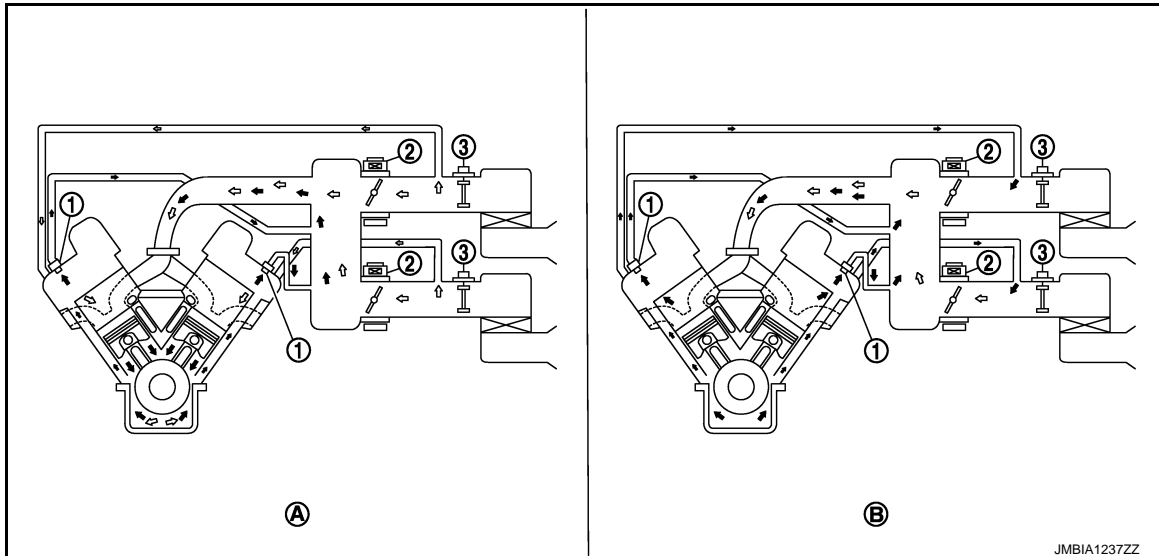

- |                     |                                       |                         |
|---------------------|---------------------------------------|-------------------------|
| 1. PCV valve        | 2. Electric throttle control actuator | 3. Mass air flow sensor |
| A. Normal condition | B. Hi-load condition                  |                         |

↵: Fresh air  
 ←: Blow-by air

This system returns blow-by gas to the intake manifold.

The positive crankcase ventilation (PCV) valve is provided to conduct crankcase blow-by gas to the intake manifold.

During partial throttle operation of the engine, the intake manifold sucks the blow-by gas through the PCV valve.

Normally, the capacity of the valve is sufficient to handle any blow-by and a small amount of ventilating air. The ventilating air is drawn from the air inlet tubes into the crankcase. In this process the air passes through the hose connecting air inlet tubes to rocker cover.

Under full-throttle condition, the manifold vacuum is insufficient to draw the blow-by flow through the valve. The flow goes through the hose connection in the reverse direction.

On vehicles with an excessively high blow-by, the valve does not meet the requirement. This is because some of the flow will go through the hose connection to the air inlet tubes under all conditions.

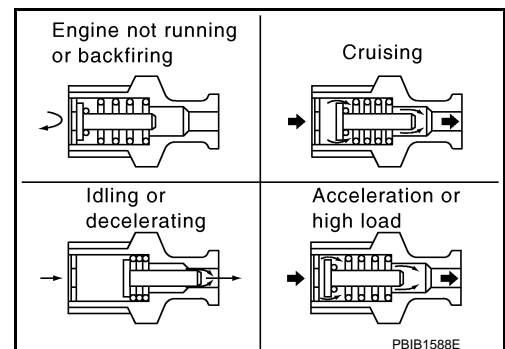

# STRUCTURE AND OPERATION

< SYSTEM DESCRIPTION >

[VQ37VHR FOR MEXICO]

## On Board Refueling Vapor Recovery (ORVR)

INFOID:000000007729671

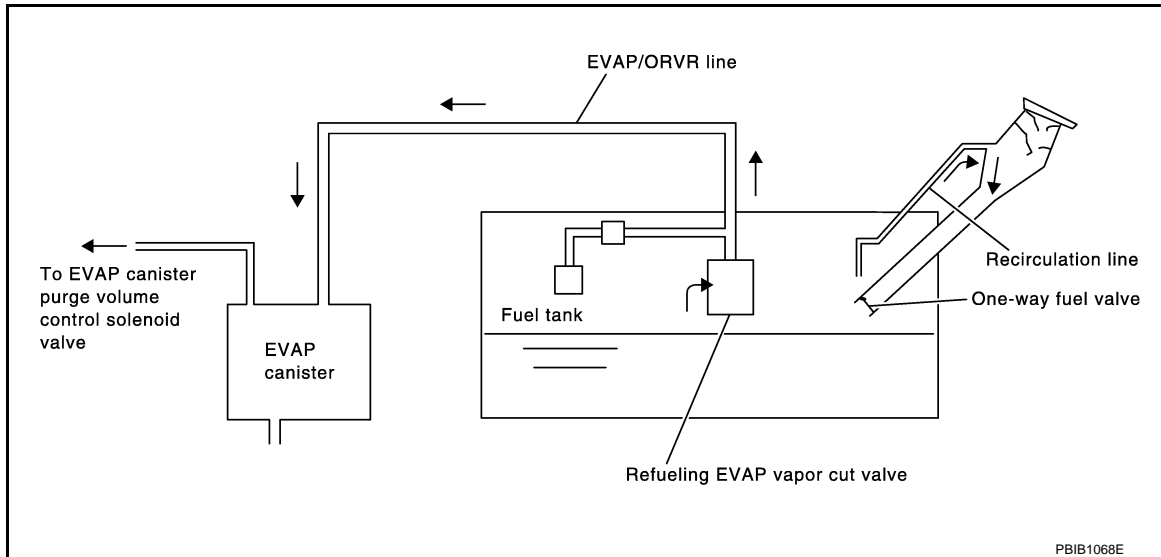

From the beginning of refueling, the air and vapor inside the fuel tank go through refueling EVAP vapor cut valve and EVAP/ORVR line to the EVAP canister. The vapor is absorbed by the EVAP canister and the air is released to the atmosphere.

When the refueling has reached the full level of the fuel tank, the refueling EVAP vapor cut valve is closed and refueling is stopped because of auto shut-off. The vapor which was absorbed by the EVAP canister is purged during driving.

### **WARNING:**

When conducting inspections below, be sure to observe the following:

- Put a "CAUTION: FLAMMABLE" sign in workshop.
- Never smoke while servicing fuel system. Keep open flames and sparks away from work area.
- Always furnish the workshop with a CO<sub>2</sub> fire extinguisher.

### **CAUTION:**

- Before removing fuel line parts, carry out the following procedures:
  - Put drained fuel in an explosion-proof container and put lid on securely.
  - Release fuel pressure from fuel line. Refer to [EC-667, "Work Procedure"](#).
  - Disconnect battery ground cable.
- Always replace O-ring when the fuel gauge retainer is removed.
- Never kink or twist hose and tube when they are installed.
- Never tighten hose and clamps excessively to avoid damaging hoses.
- After installation, run engine and check for fuel leaks at connections.
- Never attempt to top off the fuel tank after the fuel pump nozzle shuts off automatically. Continued refueling may cause fuel overflow, resulting in fuel spray and possibly a fire.

A  
EC  
C  
D  
E  
F  
G  
H  
I  
J  
K  
L  
M  
N  
O  
P

## SYSTEM

### ENGINE CONTROL SYSTEM

### ENGINE CONTROL SYSTEM : System Diagram

INFOID:000000007729672

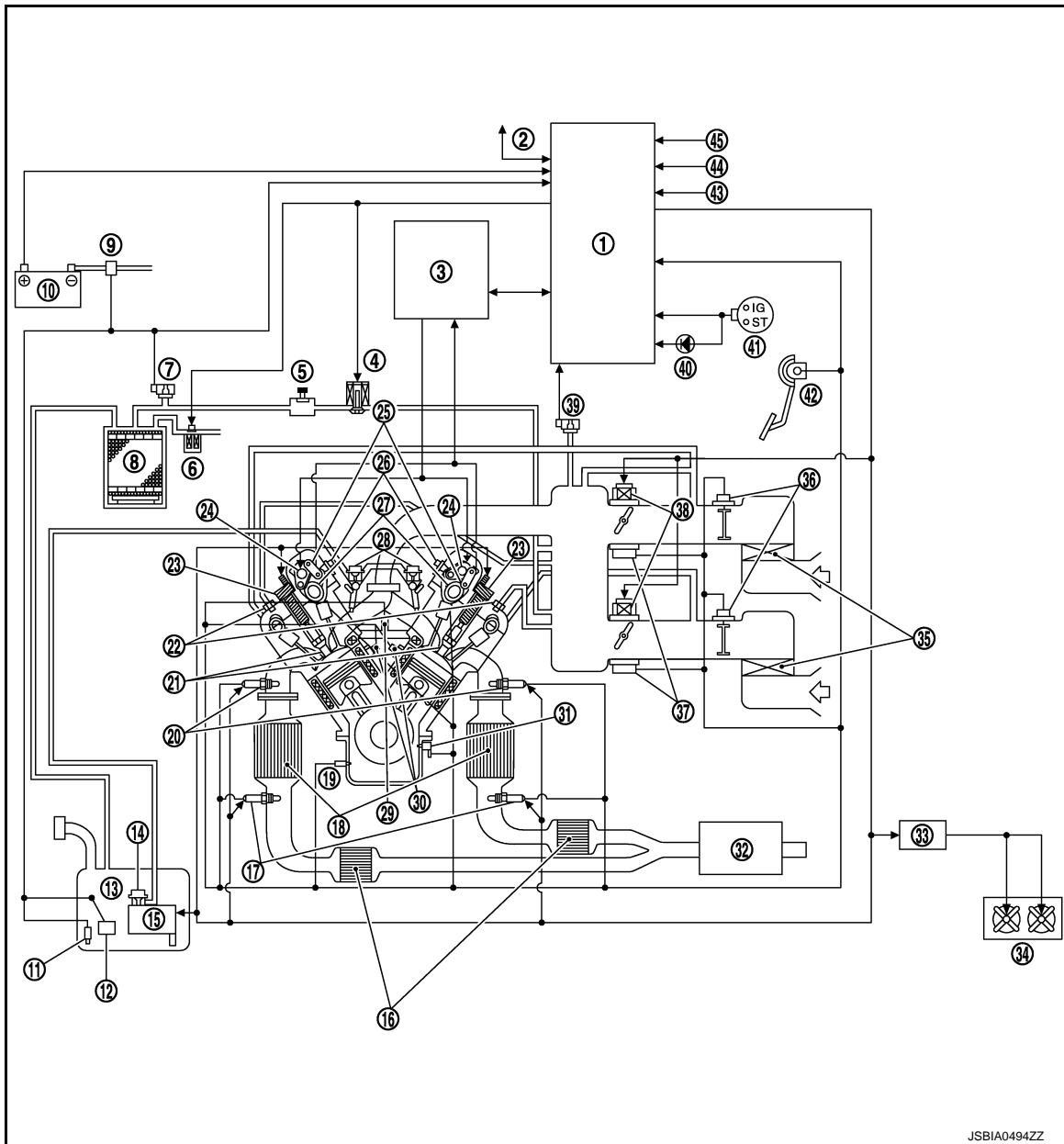

JSBIA0494ZZ

- |  |  |   |
|--|--|---|
| 1. ECM   | 2. Can communication                           | 3. VVEL control module                                      |
| 4. EVAP canister purge volume control solenoid valve | 5. EVAP service port                           | 6. EVAP canister vent control valve                         |
| 7. EVAP control system pressure sensor               | 8. EVAP canister                               | 9. Battery current sensor (with Battery temperature sensor) |
| 10. Battery  | 11. Fuel tank temperature sensor               | 12. Fuel level sensor                                       |
| 13. Fuel tank  | 14. Fuel pressure regulator                    | 15. Fuel pump   |
| 16. Three way catalyst 2                             | 17. Heated oxygen sensor 2                     | 18. Three way catalyst 1                                    |
| 19. Engine oil temperature sensor                    | 20. A/F sensor 1                               | 21. Spark plug  |
| 22. PCV valve  | 23. Ignition coil (with power transistor)      | 24. VVEL actuator motor                                     |
| 25. VVEL control shaft position sensor               | 26. Intake valve timing control solenoid valve | 27. Camshaft position sensor (PHASE)                        |

# SYSTEM

## < SYSTEM DESCRIPTION >

[VQ37VHR FOR MEXICO]

- |  |                                       |   |
|--|---------------------------------------|---|
| 28. Fuel damper                        | 29. Engine coolant temperature sensor | 30. Knock sensor  |
| 31. Crankshaft position sensor (POS)   | 32. Muffler                           | 33. Cooling fan control module                                |
| 34. Cooling fan                        | 35. Air cleaner                       | 36. Mass air flow sensor (with intake air temperature sensor) |
| 37. Electric throttle control actuator | 38. Throttle position sensor          | 39. Manifold absolute pressure (MAP) sensor                   |
| 40. MIL                                | 41. Ignition switch                   | 42. Accelerator pedal position sensor                         |
| 43. Power steering pressure sensor     | 44. Refrigerant pressure sensor       | 45. PNP signal  |

A

EC

C

## ENGINE CONTROL SYSTEM : System Description

INFOID:000000007729673

ECM performs various controls such as fuel injection control and ignition timing control.

## MULTIPOINT FUEL INJECTION SYSTEM

## MULTIPOINT FUEL INJECTION SYSTEM : System Diagram

INFOID:000000007729674

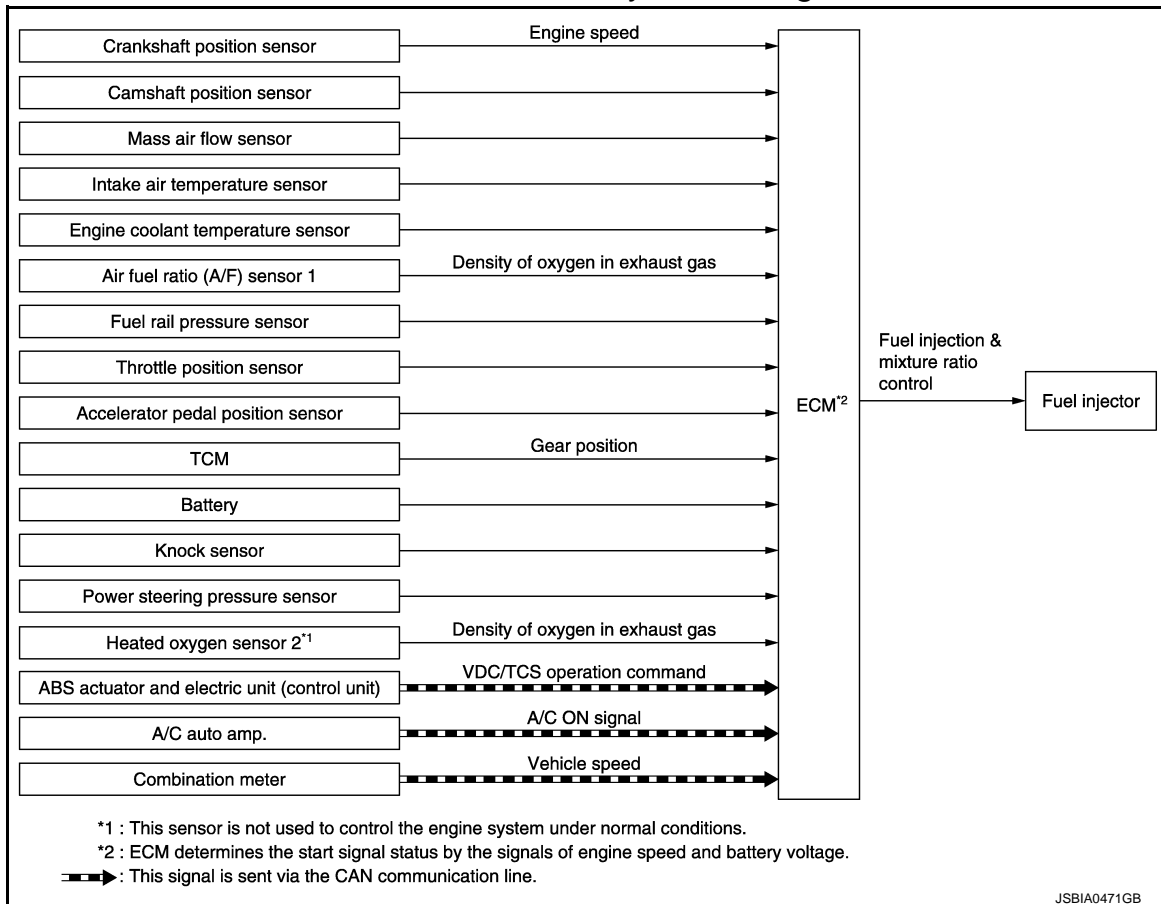

D

E

F

G

H

I

J

K

L

M

## MULTIPOINT FUEL INJECTION SYSTEM : System Description

INFOID:000000007729675

## INPUT/OUTPUT SIGNAL CHART

N

O

P

# SYSTEM

< SYSTEM DESCRIPTION >

[VQ37VHR FOR MEXICO]

| Sensor  | Input Signal to ECM               | ECM function                           | Actuator      |
|---|-----------------------------------|--|---------------|
| Crankshaft position sensor (POS)                | Engine speed*3<br>Piston position | Fuel injection & mixture ratio control | Fuel injector |
| Camshaft position sensor (PHASE)                |                                   |  |               |
| Mass air flow sensor                            | Amount of intake air              |  |               |
| Intake air temperature sensor                   | Intake air temperature            |  |               |
| Engine coolant temperature sensor               | Engine coolant temperature        |  |               |
| Air fuel ratio (A/F) sensor 1                   | Density of oxygen in exhaust gas  |  |               |
| Throttle position sensor                        | Throttle position                 |  |               |
| Accelerator pedal position sensor               | Accelerator pedal position        |  |               |
| TCM   | Gear position                     |  |               |
| Battery   | Battery voltage*3                 |  |               |
| Knock sensor                                    | Engine knocking condition         |  |               |
| Power steering pressure sensor                  | Power steering operation          |  |               |
| Heated oxygen sensor 2*1                        | Density of oxygen in exhaust gas  |  |               |
| ABS actuator and electric unit (control unit)*2 | VDC/TCS operation command         |  |               |
| A/C auto amp.                                   | A/C ON signal*2                   |  |               |
| Combination meter                               | Vehicle speed*2                   |  |               |

\*1: This sensor is not used to control the engine system under normal conditions.

\*2: This signal is sent to the ECM via the CAN communication line.

\*3: ECM determines the start signal status by the signals of engine speed and battery voltage.

## SYSTEM DESCRIPTION

The amount of fuel injected from the fuel injector is determined by the ECM. The ECM controls the length of time the valve remains open (injection pulse duration). The amount of fuel injected is a program value in the ECM memory. The program value is preset by engine operating conditions. These conditions are determined by input signals (for engine speed and intake air) from the crankshaft position sensor (POS), camshaft position sensor (PHASE) and the mass air flow sensor.

## VARIOUS FUEL INJECTION INCREASE/DECREASE COMPENSATION

In addition, the amount of fuel injected is compensated to improve engine performance under various operating conditions as listed below.

<Fuel increase>

- During warm-up
- When starting the engine
- During acceleration
- Hot-engine operation
- When selector lever is changed from N to D
- High-load, high-speed operation

<Fuel decrease>

- During deceleration
- During high engine speed operation

## MIXTURE RATIO FEEDBACK CONTROL (CLOSED LOOP CONTROL)

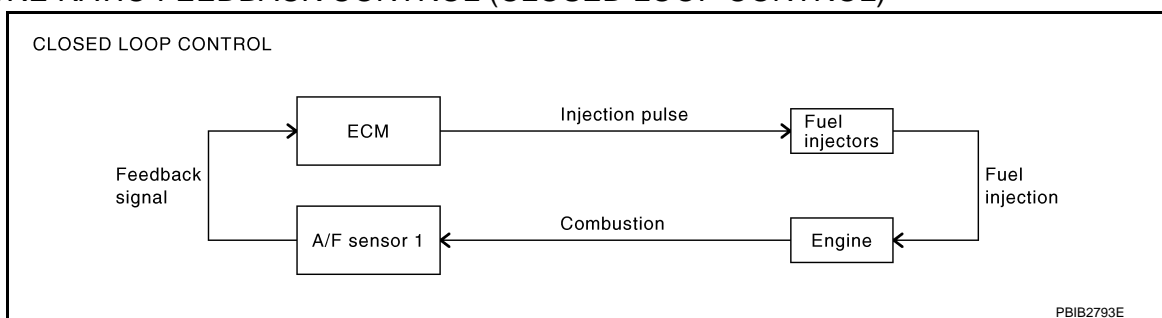

The mixture ratio feedback system provides the best air-fuel mixture ratio for driveability and emission control. The three way catalyst 1 can better reduce CO, HC and NOx emissions. This system uses A/F sensor 1 in the exhaust manifold to monitor whether the engine operation is rich or lean. The ECM adjusts the injection pulse width according to the sensor voltage signal. For more information about A/F sensor 1, refer to [EC-559, "Air Fuel Ratio Sensor 1"](#). This maintains the mixture ratio within the range of stoichiometric (ideal air-fuel mixture). This stage is referred to as the closed loop control condition.

Heated oxygen sensor 2 is located downstream of the three way catalyst 1. Even if the switching characteristics of A/F sensor 1 shift, the air-fuel ratio is controlled to stoichiometric by the signal from heated oxygen sensor 2.

• **Open Loop Control**

The open loop system condition refers to when the ECM detects any of the following conditions. Feedback control stops in order to maintain stabilized fuel combustion.

- Deceleration and acceleration
- High-load, high-speed operation
- Malfunction of A/F sensor 1 or its circuit
- Insufficient activation of A/F sensor 1 at low engine coolant temperature
- High engine coolant temperature
- During warm-up
- After shifting from N to D
- When starting the engine

**MIXTURE RATIO SELF-LEARNING CONTROL**

The mixture ratio feedback control system monitors the mixture ratio signal transmitted from A/F sensor 1. This feedback signal is then sent to the ECM. The ECM controls the basic mixture ratio as close to the theoretical mixture ratio as possible. However, the basic mixture ratio is not necessarily controlled as originally designed. Both manufacturing differences (i.e., mass air flow sensor hot wire) and characteristic changes during operation (i.e., fuel injector clogging) directly affect mixture ratio.

Accordingly, the difference between the basic and theoretical mixture ratios is monitored in this system. This is then computed in terms of "injection pulse duration" to automatically compensate for the difference between the two ratios.

"Fuel trim" refers to the feedback compensation value compared against the basic injection duration. Fuel trim includes short-term fuel trim and long-term fuel trim.

"Short-term fuel trim" is the short-term fuel compensation used to maintain the mixture ratio at its theoretical value. The signal from A/F sensor 1 indicates whether the mixture ratio is RICH or LEAN compared to the theoretical value. The signal then triggers a reduction in fuel volume if the mixture ratio is rich, and an increase in fuel volume if it is lean.

"Long-term fuel trim" is overall fuel compensation carried out over time to compensate for continual deviation of the short-term fuel trim from the central value. Continual deviation will occur due to individual engine differences, wear over time and changes in the usage environment.

**FUEL INJECTION TIMING**

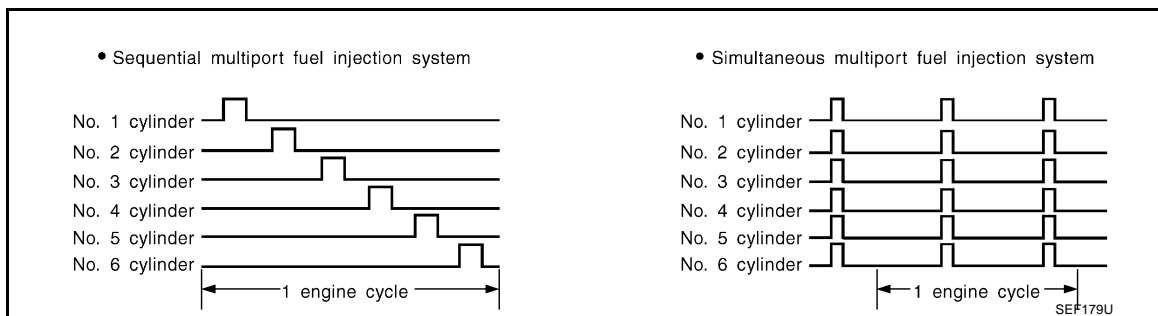

Two types of systems are used.

• **Sequential Multiport Fuel Injection System**

Fuel is injected into each cylinder during each engine cycle according to the firing order. This system is used when the engine is running.

• **Simultaneous Multiport Fuel Injection System**

Fuel is injected simultaneously into all six cylinders twice each engine cycle. In other words, pulse signals of the same width are simultaneously transmitted from the ECM.

The six injectors will then receive the signals two times for each engine cycle.

This system is used when the engine is being started and/or if the fail-safe system (CPU) is operating.

**FUEL SHUT-OFF**

# SYSTEM

< SYSTEM DESCRIPTION >

[VQ37VHR FOR MEXICO]

Fuel to each cylinder is cut off during deceleration, operation of the engine at excessively high speeds or operation of the vehicle at excessively high speeds.

## ELECTRIC IGNITION SYSTEM

### ELECTRIC IGNITION SYSTEM : System Diagram

INFOID:000000007729676

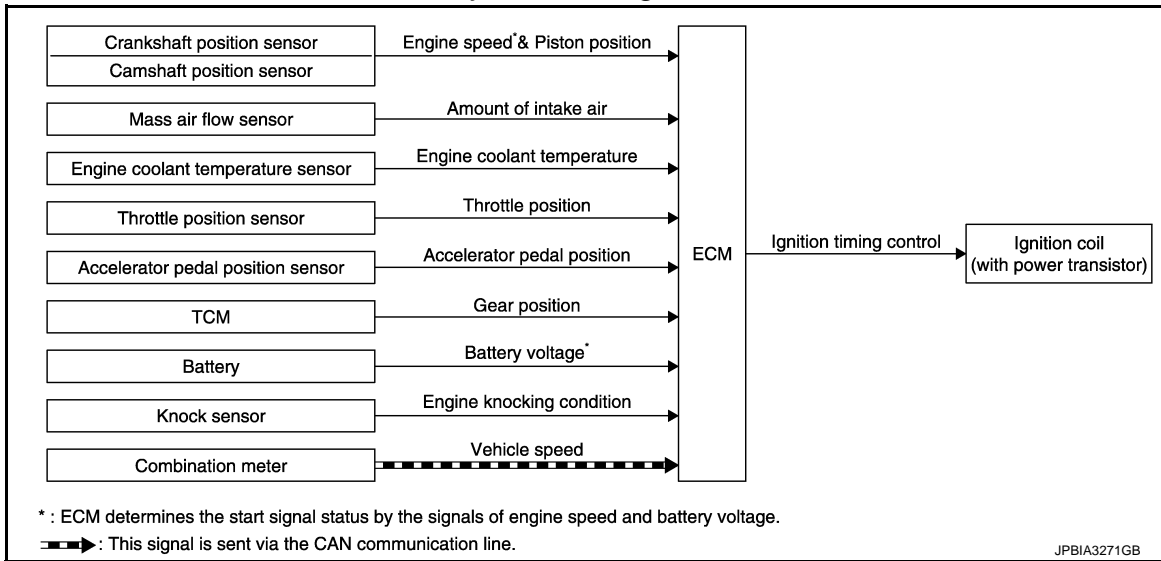

### ELECTRIC IGNITION SYSTEM : System Description

INFOID:000000007729677

#### INPUT/OUTPUT SIGNAL CHART

| Sensor                            | Input Signal to ECM               | ECM function            | Actuator                              |
|-----------------------------------|-----------------------------------|-------------------------|---------------------------------------|
| Crankshaft position sensor (POS)  | Engine speed*2<br>Piston position | Ignition timing control | Ignition coil (with power transistor) |
| Camshaft position sensor (PHASE)  |                                   |                         |                                       |
| Mass air flow sensor              | Amount of intake air              |                         |                                       |
| Engine coolant temperature sensor | Engine coolant temperature        |                         |                                       |
| Throttle position sensor          | Throttle position                 |                         |                                       |
| Accelerator pedal position sensor | Accelerator pedal position        |                         |                                       |
| TCM                               | Gear position                     |                         |                                       |
| Battery                           | Battery voltage*2                 |                         |                                       |
| Knock sensor                      | Engine knocking                   |                         |                                       |
| Combination meter                 | Vehicle speed*1                   |                         |                                       |

\*1: This signal is sent to the ECM via the CAN communication line.

\*2: ECM determines the start signal status by the signals of engine speed and battery voltage.

#### SYSTEM DESCRIPTION

Ignition order: 1 - 2 - 3 - 4 - 5 - 6

The ignition timing is controlled by the ECM to maintain the best air-fuel ratio for every running condition of the engine. The ignition timing data is stored in the ECM.

The ECM receives information such as the injection pulse width and camshaft position sensor (PHASE) signal. Computing this information, ignition signals are transmitted to the power transistor.

During the following conditions, the ignition timing is revised by the ECM according to the other data stored in the ECM.

- At starting
- During warm-up
- At idle
- At low battery voltage
- During acceleration



# SYSTEM

< SYSTEM DESCRIPTION >

[VQ37VHR FOR MEXICO]

The knock sensor retard system is designed only for emergencies. The basic ignition timing is programmed within the anti-knocking zone, if recommended fuel is used under dry conditions. The retard system does not operate under normal driving conditions. If engine knocking occurs, the knock sensor monitors the condition. The signal is transmitted to the ECM. The ECM retards the ignition timing to eliminate the knocking condition.

## AIR CONDITIONING CUT CONTROL

### AIR CONDITIONING CUT CONTROL : System Diagram

INFOID:000000007729678

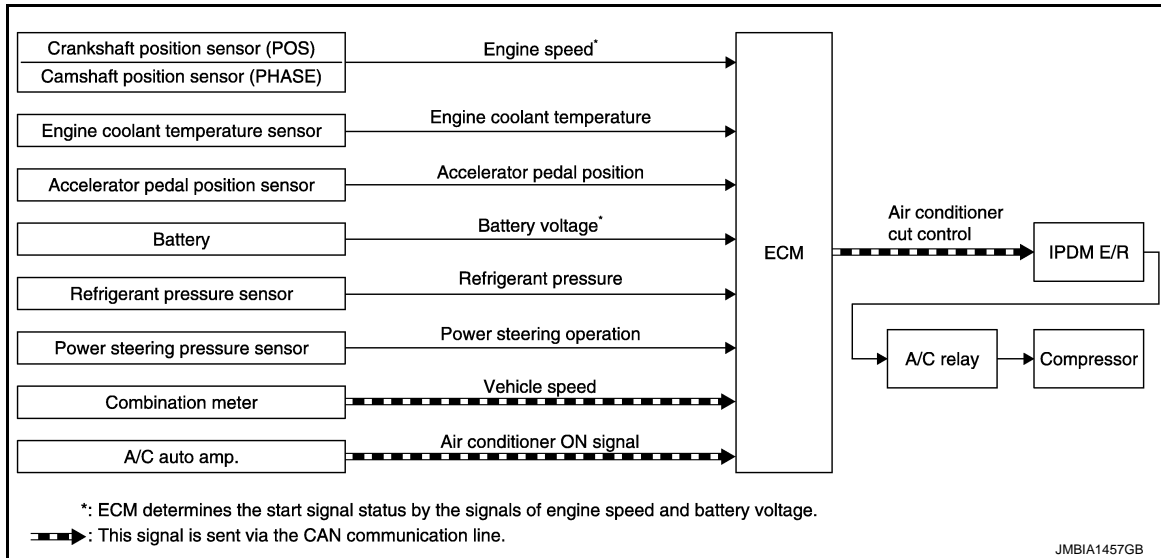

### AIR CONDITIONING CUT CONTROL : System Description

INFOID:000000007729679

#### INPUT/OUTPUT SIGNAL CHART

| Sensor   | Input Signal to ECM         | ECM function                | Actuator                                      |
|--|-----------------------------|-----------------------------|---|
| Crankshaft position sensor (POS)<br>Camshaft position sensor (PHASE) | Engine speed*2              | Air conditioner cut control | IPDM E/R<br>↓<br>A/C relay<br>↓<br>Compressor |
| Engine coolant temperature sensor                                    | Engine coolant temperature  |                             |   |
| Accelerator pedal position sensor                                    | Accelerator pedal position  |                             |   |
| Battery  | Battery voltage*2           |                             |   |
| Refrigerant pressure sensor  | Refrigerant pressure        |                             |   |
| Power steering pressure sensor                                       | Power steering operation    |                             |   |
| Combination meter  | Vehicle speed*1             |                             |   |
| A/C auto amp.  | Air conditioner ON signal*1 |                             |   |

\*1: This signal is sent to the ECM via the CAN communication line.

\*2: ECM determines the start signal status by the signals of engine speed and battery voltage.

#### SYSTEM DESCRIPTION

This system improves engine operation when the air conditioner is used. Under the following conditions, the air conditioner is turned off.

- When the accelerator pedal is fully depressed.
- When cranking the engine.
- At high engine speeds.
- When the engine coolant temperature becomes excessively high.
- When operating power steering during low engine speed or low vehicle speed.
- When engine speed is excessively low.
- When refrigerant pressure is excessively low or high.

#### AUTOMATIC SPEED CONTROL DEVICE (ASCD)

# SYSTEM

< SYSTEM DESCRIPTION >

[VQ37VHR FOR MEXICO]

## AUTOMATIC SPEED CONTROL DEVICE (ASCD) : System Diagram

INFOID:000000007729680

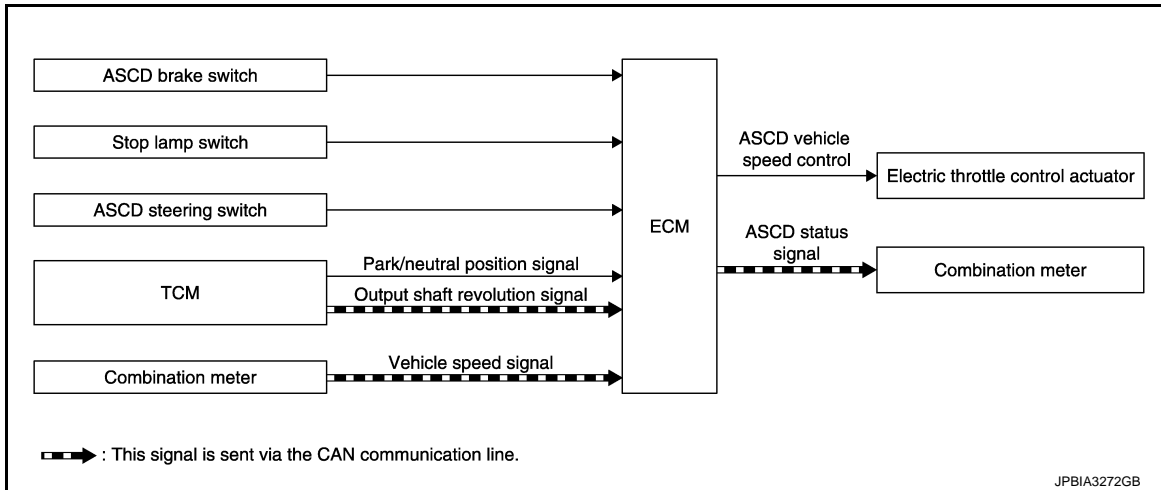

## AUTOMATIC SPEED CONTROL DEVICE (ASCD) : System Description

INFOID:000000007729681

### INPUT/OUTPUT SIGNAL CHART

| Sensor               | Input signal to ECM             | ECM function               | Actuator                           |
|----------------------|---------------------------------|----------------------------|------------------------------------|
| ASCD brake switch    | Brake pedal operation           | ASCD vehicle speed control | Electric throttle control actuator |
| Stop lamp switch     | Brake pedal operation           |                            |                                    |
| ASCD steering switch | ASCD steering switch operation  |                            |                                    |
| TCM                  | Park/neutral position signal    | ASCD status signal         | Combination meter                  |
|                      | Output shaft revolution signal* |                            |                                    |
| Combination meter    | Vehicle speed*                  |                            |                                    |

\*: This signal is sent to the ECM via the CAN communication line

### BASIC ASCD SYSTEM

Refer to Owner's Manual for ASCD operating instructions.

Automatic Speed Control Device (ASCD) allows a driver to keep vehicle at predetermined constant speed without depressing accelerator pedal. Driver can set vehicle speed in advance between approximately 35 km/h (22 MPH) and 144 km/h (89 MPH).

ECM controls throttle angle of electric throttle control actuator to regulate engine speed.

Operation status of ASCD is indicated by CRUISE indicator and SET indicator in combination meter. If any malfunction occurs in the ASCD system, it automatically deactivates control.

#### NOTE:

**Always drive vehicle in a safe manner according to traffic conditions and obey all traffic laws.**

### SET OPERATION

Press MAIN switch. (The CRUISE indicator in combination meter illuminates.)

When vehicle speed reaches a desired speed between approximately 35 km/h (22 MPH) and 144 km/h (89 MPH), press SET/COAST switch. (Then SET lamp in combination meter illuminates.)

### ACCELERATE OPERATION

If the RESUME/ACCELERATE switch is pressed during cruise control driving, increase the vehicle speed until the switch is released or vehicle speed reaches maximum speed controlled by the system.

And then ASCD will maintain the new set speed.

### CANCEL OPERATION

When any of following conditions exist, cruise operation will be canceled.

- CANCEL switch is pressed
- More than 2 switches at ASCD steering switch are pressed at the same time (Set speed will be cleared)
- Brake pedal is depressed
- Selector lever is in the N, P, R position
- Vehicle speed decreased to 13 km/h (8 MPH) lower than the set speed

- TCS system is operated
- When the ECM detects any of the following conditions, the ECM will cancel the cruise operation and inform the driver by blinking indicator lamp.
- Engine coolant temperature is slightly higher than the normal operating temperature, CRUISE lamp may blink slowly.  
When the engine coolant temperature decreases to the normal operating temperature, CRUISE lamp will stop blinking and the cruise operation will be able to work by pressing SET/COAST switch or RESUME/ACCELERATE switch.
  - Malfunction for some self-diagnoses regarding ASCD control: SET indicator will blink quickly.  
If MAIN switch is turned to OFF while ASCD is activated, all of ASCD operations will be canceled and vehicle speed memory will be erased.

## COAST OPERATION

When the SET/COAST switch is pressed during cruise control driving, decrease vehicle set speed until the switch is released. And then ASCD will maintain the new set speed.

## RESUME OPERATION

When the RESUME/ACCELERATE switch is pressed after cancel operation other than pressing MAIN switch is performed, vehicle speed will return to last set speed. To resume vehicle set speed, vehicle condition must meet following conditions.

- Brake pedal is released
- A/T selector lever is in the P and N positions
- Vehicle speed is greater than 35 km/h (22 MPH) and less than 144 km/h (89 MPH)

## CAN COMMUNICATION

### CAN COMMUNICATION : System Description

INFOID:000000007729682

CAN (Controller Area Network) is a serial communication line for real time application. It is an on-vehicle multiplex communication line with high data communication speed and excellent error detection ability. Many electronic control units are equipped onto a vehicle, and each control unit shares information and links with other control units during operation (not independent). In CAN communication, control units are connected with 2 communication lines (CAN H line, CAN L line) allowing a high rate of information transmission with less wiring. Each control unit transmits/receives data but selectively reads required data only.

Refer to [LAN-17. "CAN COMMUNICATION SYSTEM : CAN Communication Control Circuit"](#), about CAN communication for detail.

## COOLING FAN CONTROL

### COOLING FAN CONTROL : System Diagram

INFOID:000000007729683

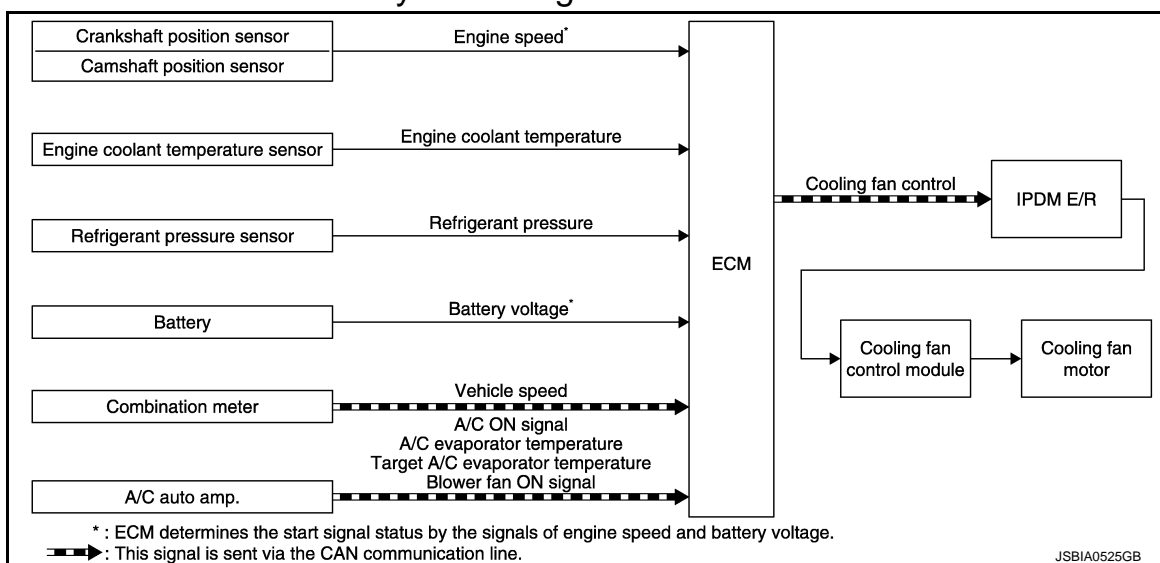

### COOLING FAN CONTROL : System Description

INFOID:000000007729684

## INPUT/OUTPUT SIGNAL CHART

# SYSTEM

< SYSTEM DESCRIPTION >

[VQ37VHR FOR MEXICO]

| Sensor   | Input signal to ECM                 | ECM function        | Actuator  |
|--|-------------------------------------|---------------------|---|
| Crankshaft position sensor (POS)<br>Camshaft position sensor (PHASE) | Engine speed*1                      | Cooling fan control | IPDM E/R<br>↓<br>Cooling fan control module<br>↓<br>Cooling fan motor |
| Engine coolant temperature sensor                                    | Engine coolant temperature          |                     |   |
| Refrigerant pressure sensor  | Refrigerant pressure                |                     |   |
| Battery  | Battery voltage*1                   |                     |   |
| Combination meter  | Vehicle speed*2                     |                     |   |
| A/C auto amp.  | A/C ON signal*2                     |                     |   |
|  | A/C evaporator temperature*2        |                     |   |
|  | Target A/C evaporator temperature*2 |                     |   |
|  | Blower fan ON signal*2              |                     |   |

\*1: The ECM determines the start signal status by the signals of engine speed and battery voltage.

\*2: This signal is sent to ECM via the CAN communication line.

## SYSTEM DESCRIPTION

ECM controls cooling fan speed corresponding to vehicle speed, engine coolant temperature, air conditioner ON signal, refrigerant pressure, target A/C evaporator temperature and A/C evaporator temperature. Cooling fan control signal is sent to IPDM E/R from ECM by CAN communication line. Then, IPDM E/R sends ON/OFF pulse duty signal to cooling fan control module. Corresponding to this ON/OFF pulse duty signal, cooling fan control module gives cooling fan motor operating voltage to cooling fan motors. Cooling fan speed is controlled by duty cycle of cooling fan motor operating voltage sent from cooling fan control module.

## EVAPORATIVE EMISSION SYSTEM

### EVAPORATIVE EMISSION SYSTEM : System Diagram

INFOID:000000007729685

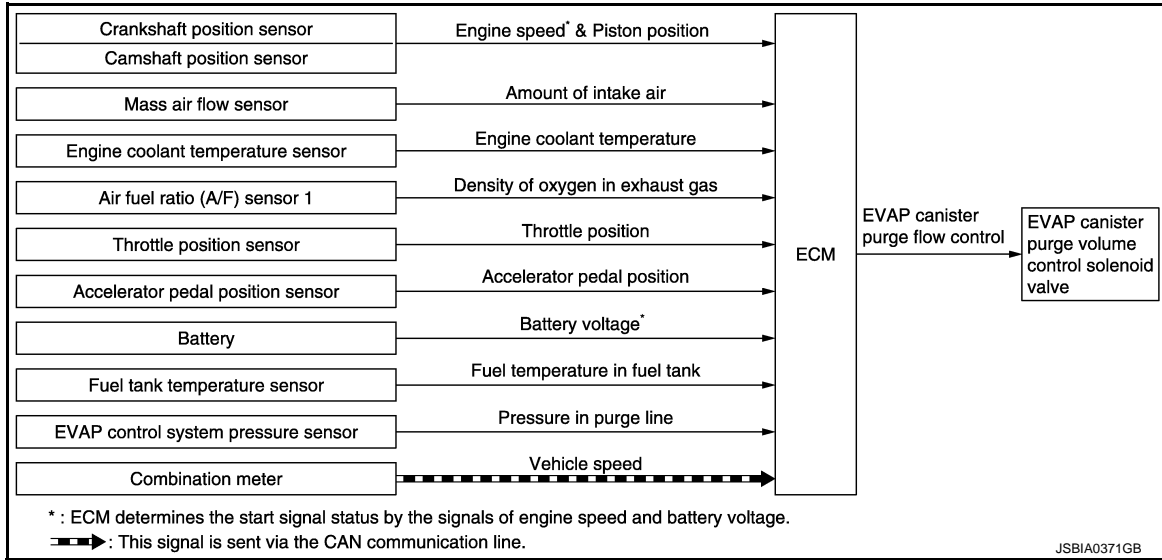

### EVAPORATIVE EMISSION SYSTEM : System Description

INFOID:000000007729686

### INPUT/OUTPUT SIGNAL CHART

# SYSTEM

< SYSTEM DESCRIPTION >

[VQ37VHR FOR MEXICO]

| Sensor   | Input signal to ECM   | ECM function                        | Actuator   |
|--|---|-------------------------------------|--|
| Crankshaft position sensor<br>Camshaft position sensor | Engine speed*1  | EVAP canister<br>purge flow control | EVAP canister purge volume<br>control solenoid valve |
| Mass air flow sensor                                   | Amount of intake air  |                                     |  |
| Engine coolant temperature sensor                      | Engine coolant temperature  |                                     |  |
| Battery  | Battery voltage*1   |                                     |  |
| Throttle position sensor                               | Throttle position   |                                     |  |
| Accelerator pedal position sensor                      | Accelerator pedal position  |                                     |  |
| Air fuel ratio (A/F) sensor 1                          | Density of oxygen in exhaust gas<br>(Mixture ratio feedback signal) |                                     |  |
| Fuel tank temperature sensor                           | Fuel temperature in fuel tank                                       |                                     |  |
| EVAP control system pressure sensor                    | Pressure in purge line  |                                     |  |
| Combination meter                                      | Vehicle speed*2   |                                     |  |

\*1: ECM determines the start signal status by the signals of engine speed and battery voltage.

\*2: This signal is sent to the ECM via the CAN communication line.

## SYSTEM DESCRIPTION

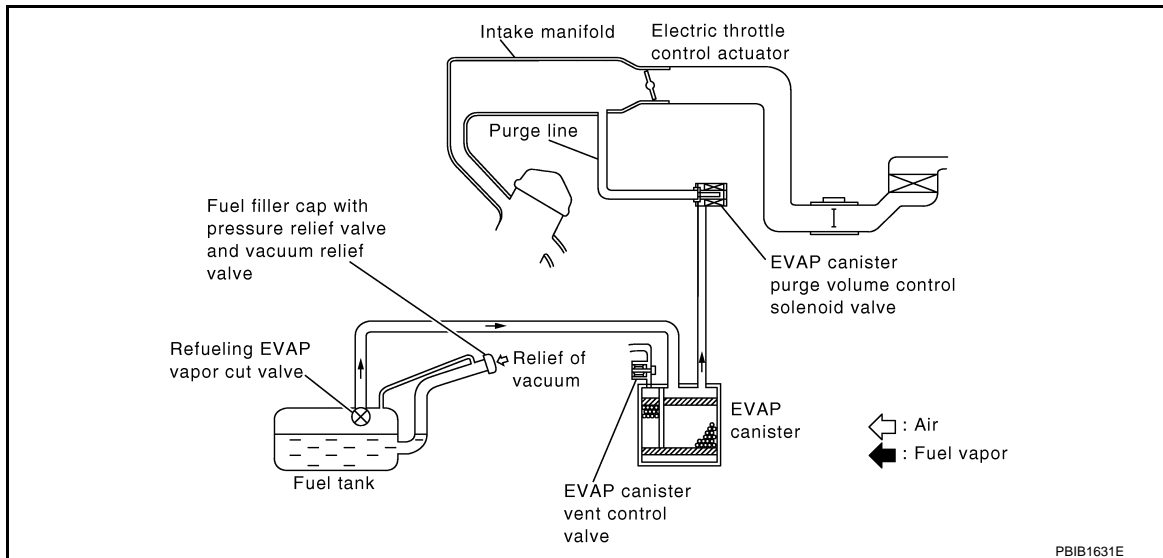

The evaporative emission system is used to reduce hydrocarbons emitted into the atmosphere from the fuel system. This reduction of hydrocarbons is accomplished by activated charcoals in the EVAP canister. The fuel vapor in the sealed fuel tank is led into the EVAP canister which contains activated carbon and the vapor is stored there when the engine is not operating or when refueling to the fuel tank. The vapor in the EVAP canister is purged by the air through the purge line to the intake manifold when the engine is operating. EVAP canister purge volume control solenoid valve is controlled by ECM. When the engine operates, the flow rate of vapor controlled by EVAP canister purge volume control solenoid valve is proportionally regulated as the air flow increases. EVAP canister purge volume control solenoid valve also shuts off the vapor purge line during decelerating and idling.

## ENGINE PROTECTION CONTROL AT LOW ENGINE OIL PRESSURE

## ENGINE PROTECTION CONTROL AT LOW ENGINE OIL PRESSURE : System Dia-

gram

INFOID:000000007768316

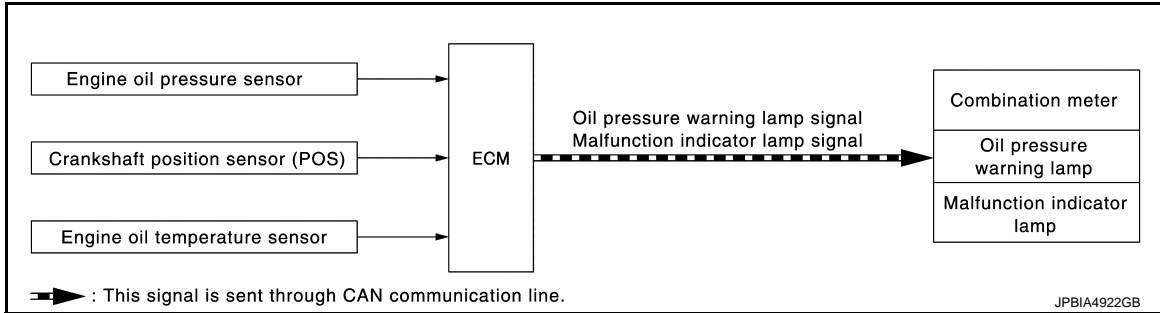

## ENGINE PROTECTION CONTROL AT LOW ENGINE OIL PRESSURE : System Description

INFOID:000000007768317

### INPUT/OUTPUT SIGNAL CHART

| Sensor                           | Input signal to ECM    | ECM function  | Actuator   |
|----------------------------------|------------------------|---|--|
| Engine oil pressure sensor       | Engine pressure        | Engine protection control<br>• Oil pressure warning lamp signal<br>• FUEl cut control | Combination meter<br>• Oil pressure warning lamp |
| Crankshaft position sensor (POS) | Engine speed           |   |  |
| Engine oil temperature sensor    | Engine oil temperature |   |  |

### SYSTEM DESCRIPTION

- The engine protection control at low engine oil pressure warns the driver of a decrease in engine oil pressure by the oil pressure warning lamp a before the engine becomes damaged.
- When detecting a decrease in engine oil pressure at an engine speed less than 1,000 rpm, ECM transmits an oil pressure warning lamp signal to the combination meter. The combination meter turns ON the oil pressure warning lamp, according to the signal.

| Decrease in engine oil pressure | Engine speed        | Combination meter         |
|---------------------------------|---------------------|---------------------------|
|                                 |                     | Oil pressure warning lamp |
| Detection                       | Less than 1,000 rpm | ON*                       |
|                                 | 1,000 rpm or more   | ON                        |

\*: When detecting a normal engine oil pressure, ECM turns OFF the oil pressure warning lamp.

### INTAKE VALVE TIMING CONTROL

#### INTAKE VALVE TIMING CONTROL : System Diagram

INFOID:000000007729689

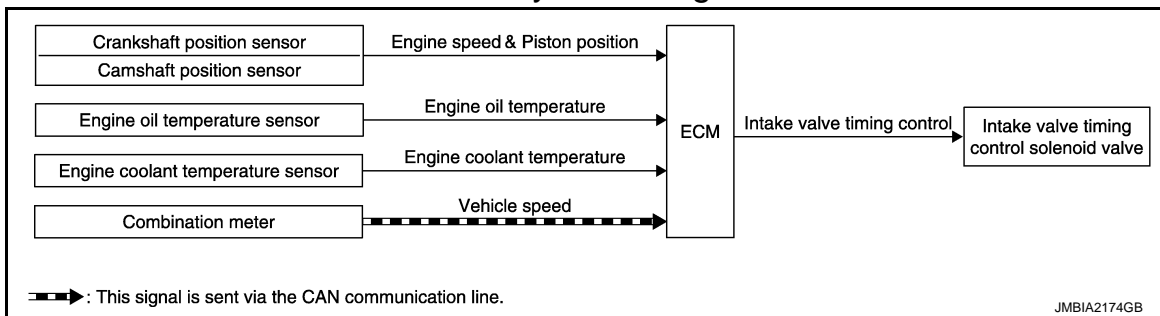

#### INTAKE VALVE TIMING CONTROL : System Description

INFOID:000000007729690

### INPUT/OUTPUT SIGNAL CHART

# SYSTEM

< SYSTEM DESCRIPTION >

[VQ37VHR FOR MEXICO]

| Sensor                            | Input signal to ECM              | ECM function                | Actuator                                   |
|-----------------------------------|----------------------------------|-----------------------------|--|
| Crankshaft position sensor (POS)  | Engine speed and piston position | Intake valve timing control | Intake valve timing control solenoid valve |
| Camshaft position sensor (PHASE)  |                                  |                             |  |
| Engine oil temperature sensor     | Engine oil temperature           |                             |  |
| Engine coolant temperature sensor | Engine coolant temperature       |                             |  |
| Combination meter                 | Vehicle speed*                   |                             |  |

\*: This signal is sent to the ECM via the CAN communication line

## SYSTEM DESCRIPTION

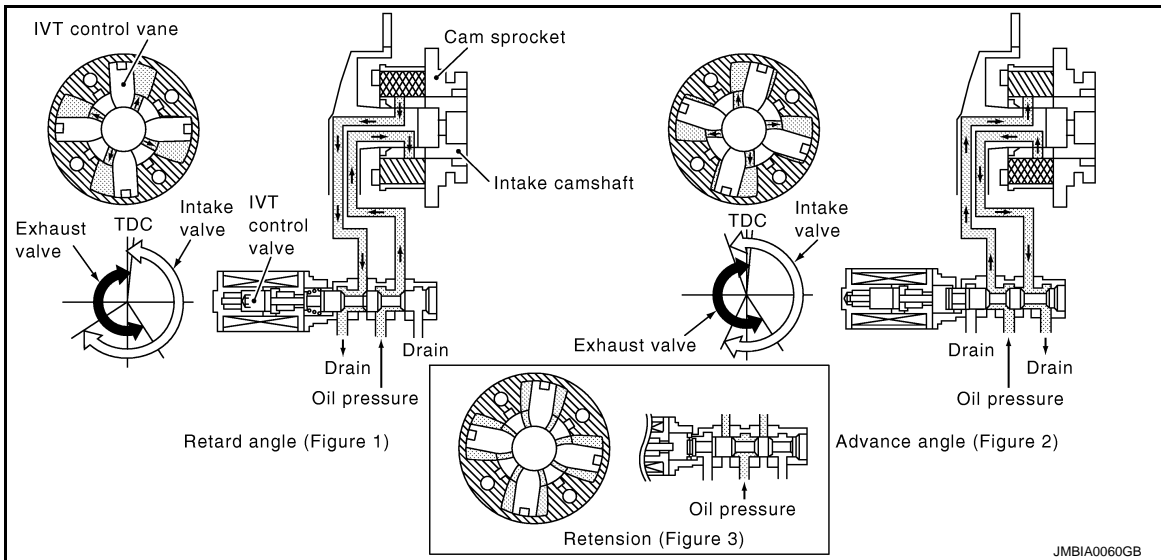

This mechanism hydraulically controls cam phases continuously with the fixed operating angle of the intake valve.

The ECM receives signals such as crankshaft position, camshaft position, engine speed, and engine coolant temperature. Then, the ECM sends ON/OFF pulse duty signals to the intake valve timing (IVT) control solenoid valve depending on driving status. This makes it possible to control the shut/open timing of the intake valve to increase engine torque in low/mid speed range and output in high-speed range.

## VVEL SYSTEM

### VVEL SYSTEM : System Diagram

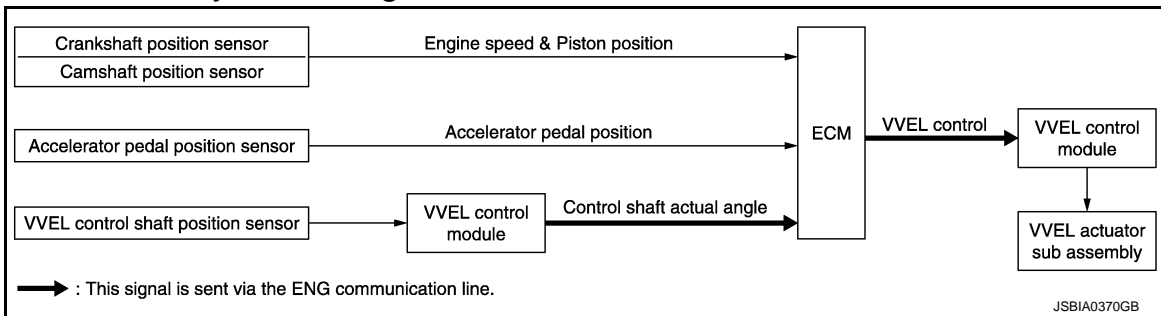

### VVEL SYSTEM : System Description

#### INPUT/OUTPUT SIGNAL CHART

# SYSTEM

< SYSTEM DESCRIPTION >

[VQ37VHR FOR MEXICO]

| Sensor   | Input signal to ECM              | ECM function | Actuator   |
|--|----------------------------------|--------------|--|
| Camshaft position sensor<br>Crankshaft position sensor         | Engine speed and piston position | VVEL control | VVEL control module<br>↓<br>VVEL actuator sub assembly |
| Accelerator pedal position sensor                              | Accelerator pedal position       |              |  |
| VVEL control shaft position sensor<br>↓<br>VVEL control module | Control shaft actual angle       |              |  |

## SYSTEM DESCRIPTION

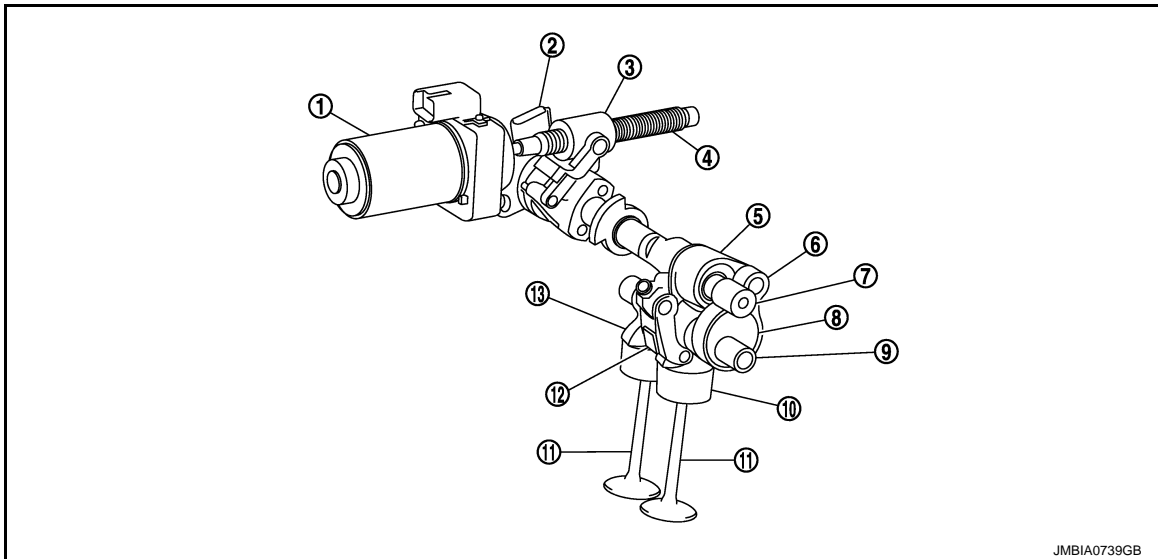

JMBIA0739GB

- |                        |                                       |                   |
|------------------------|---------------------------------------|-------------------|
| 1. VVEL actuator motor | 2. VVEL control shaft position sensor | 3. Ball screw nut |
| 4. Ball screw shaft    | 5. Rocker arm                         | 6. Link A         |
| 7. Control shaft       | 8. Eccentric cam                      | 9. Drive shaft    |
| 10. Valve lifter       | 11. Intake valve                      | 12. Link B        |
| 13. Output cam         |                                       |                   |

VVEL (Variable Valve Event & Lift) is a system that controls valve event and valve lift continuously. Rotational movement of the drive shaft equipped with eccentric cam is transmitted to output cam via the rocker arm and two kinds of links to depress the intake valve. ECM decides the target valve lift according to the driving condition and sends the command signal to the VVEL control module. The VVEL control module controls the rotation of the control shaft using the VVEL actuator motor and changes the movement of the output cam by shifting the link supporting point. As a result, valve lift changes continuously to improve engine output and response.

## Infiniti Drive Mode Selector



Infiniti Drive Mode Selector : System Description

INFOID:000000007729693

System Diagram

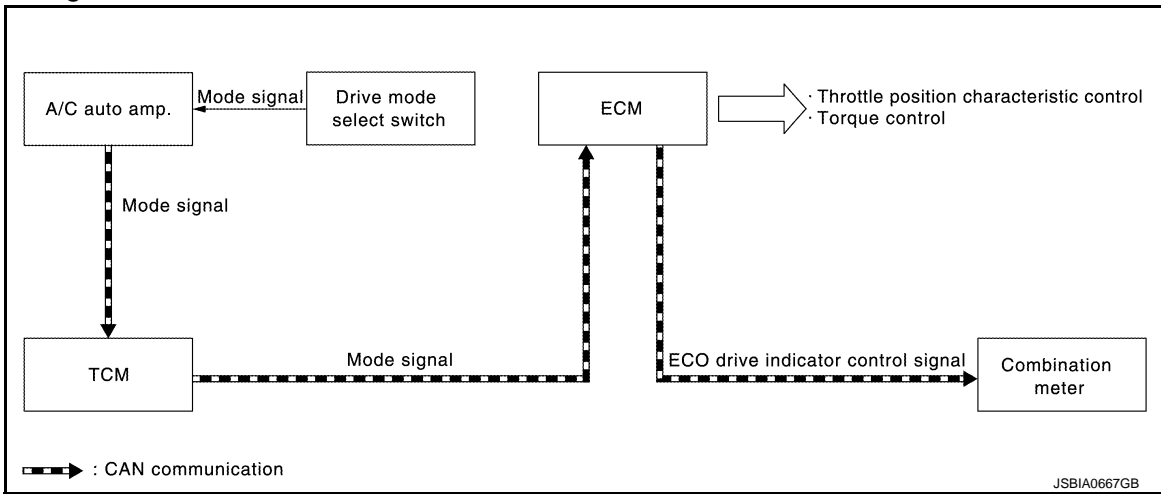

NOTE:

- This section provides descriptions only about the control by ECM.  
For overall control, refer to [DMS-5, "Infiniti Drive Mode Selector : System Description"](#).

Infiniti drive mode selector

- A/C auto amp. receives an operation state signal of the drive mode select switch and transmits a mode signal (see below) to TCM via CAN communication.
  - STANDARD: ON/OFF
  - SPORT: ON/OFF
  - ECO: ON/OFF
  - SNOW: ON/OFF
- TCM transmits a mode state signal to ECM via CAN communication, based on a ECO mode signal received from the A/C auto amp.
- ECM controls throttle angle characteristics and torque appropriate to each mode, based on a ECO mode signal received from TCM via CAN communication.
- The combination meter turns ON the ECO drive indicator when in ECO mode, based on a ECO drive indicator control signal received from ECM via CAN communication.

Control

- With the drive mode selector, a drive mode select switch installed at the top of the center console switches a vehicle drive mode, changes throttle angle characteristics, and controls torque.
- Vehicle characteristics are controlled in the following modes, on the basis of STANDARD mode ("●" position of the drive mode select switch).
  - SPORT: Changing throttle angle characteristics allows to use a high engine performance range and increases driving performance.
  - ECO: Changing throttle angle characteristics and controlling torque, ECO drive indicator enhance fuel economy in actual traffic.
  - SNOW: Changing throttle angle characteristics enhances driving performance on roads with a low coefficient of friction.

| Control item | Vehicle drive mode |     |      | Description   |
|--------------|--------------------|-----|------|---|
|              | SPORT              | ECO | SNOW |   |
| Engine       | ×                  | ×   | ×    | Changes throttle angle and controls torque* and the ECO drive indicator*. |

\*: Torque control and the ECO drive indicator is available only when in ECO mode.

ECO drive indicator control

ECO drive indicator turns ON in ECO mode.

# SYSTEM

< SYSTEM DESCRIPTION >

[VQ37VHR FOR MEXICO]

| ECO drive indicator | Driving condition                                  |
|---------------------|--|
| ON (Green)          | Within the ECO drive range.                        |
| ON (Orange)         | Over the ECO drive range.                          |
| OFF                 | Low-speed range [approx. 3 MPH (4.8 km/h) or less] |

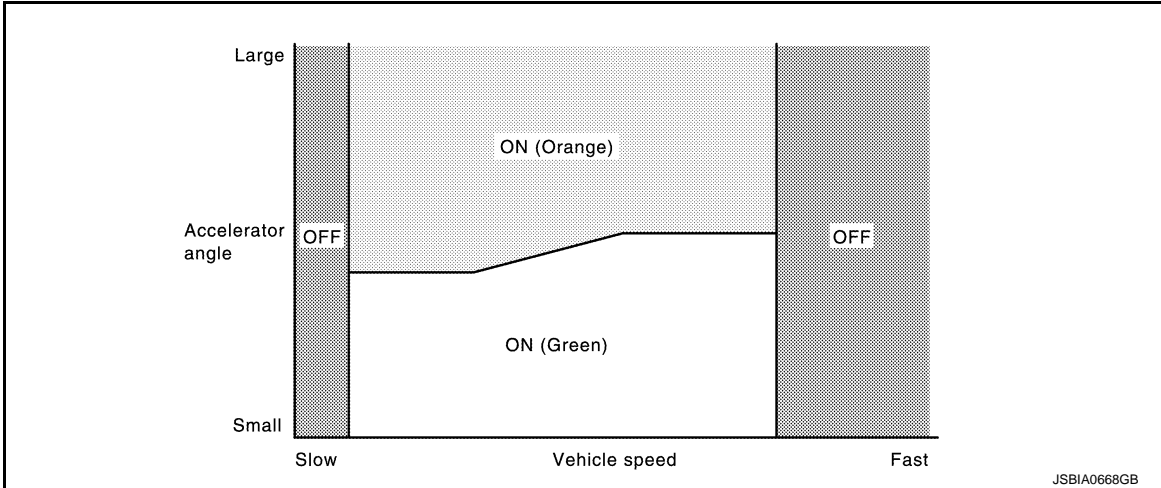

- NOTE:**  
 ECO drive indicator turns OFF under the following conditions.
- Intelligent cruise control in operation.
  - Selector lever is in R range.

JSBIA0668GB

OPERATION

AUTMATIC SPEED CONTROL DEVICE (ASCD)

AUTMATIC SPEED CONTROL DEVICE (ASCD) : Switch Name and Function

INFOID:000000007729694

A

EC

SWITCHES AND INDICATORS

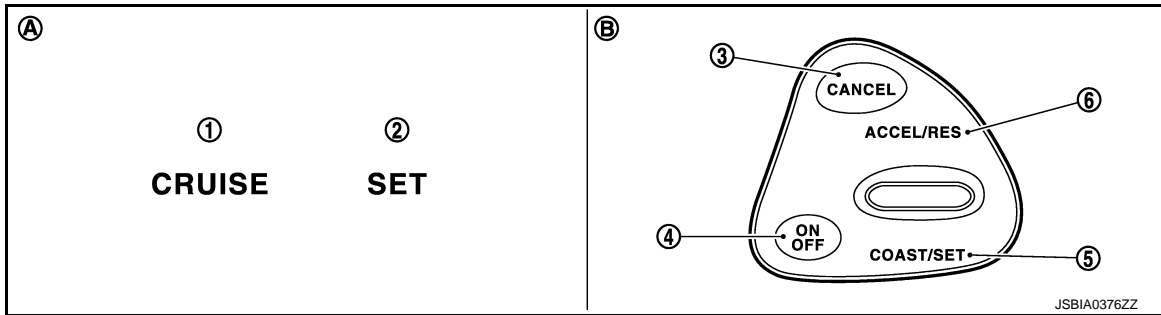

- 1. CRUISE indicator
- 2. SET indicator
- 3. CANCEL switch
- 4. ASCD MAIN switch
- 5. COAST/SET switch
- 6. ACCEL/RES switch (ACCELERATE/RESUME)

- A. On the combination meter (Information display)
- B. On the steering wheel

SET SPEED RANGE

ASCD system can be set the following vehicle speed.

| Minimum speed (Approx.) | Maximum speed (Approx.) |
|-------------------------|-------------------------|
| 35 km/h (22 MPH)        | 144 km/h (89 MPH)       |

SWITCH OPERATION

| Item                               | Function   |
|------------------------------------|--|
| CANCEL switch                      | Cancels the cruise control driving.  |
| RES / + switch (RESUME/ACCELERATE) | <ul style="list-style-type: none"> <li>• Resumes the set speed.</li> <li>• Increases speed incrementally during cruise control driving.</li> </ul>     |
| SET / - switch (SET/COAST)         | <ul style="list-style-type: none"> <li>• Sets desired cruise speed.</li> <li>• Decreases speed incrementally during cruise control driving.</li> </ul> |
| ASCD MAIN switch                   | Master switch to activate the ASCD system.   |

CANCEL OPERATION

When any of following conditions exist, cruise operation will be canceled.

- CANCEL switch is pressed
- ASCD MAIN switch pressed (Set speed is cleared)
- More than 2 switches at ASCD steering switch are pressed at the same time (Set speed will be cleared)
- Brake pedal is depressed
- Selector lever position is changed to N, P or R
- Vehicle speed decreased to 13 km/h (8 MPH) lower than the set speed
- TCS system is operated

When the ECM detects any of the following conditions, the ECM will cancel the cruise operation and inform the driver by blinking indicator.

- Engine coolant temperature is slightly higher than the normal operating temperature, CRUISE indicator may blink slowly.  
When the engine coolant temperature decreases to the normal operating temperature, CRUISE indicator will stop blinking and the cruise operation will be able to work by pressing SET/COAST switch or RESUME/ACCELERATE switch.
- Malfunction for some self-diagnoses regarding ASCD control: SET indicator will blink quickly.

C

D

E

F

G

H

I

J

K

L

M

N

O

P

## OPERATION

< SYSTEM DESCRIPTION >

[VQ37VHR FOR MEXICO]

---

If MAIN switch is turned to OFF during ASCD is activated, all of ASCD operations will be canceled and vehicle speed memory will be erased.

## HANDLING PRECAUTION

### Infiniti Drive Mode Selector

INFOID:000000007729695

#### ECO DRIVE INDICATOR LAMP CONTROL

- ECO drive indicator turns OFF under the following conditions.
  - While driving at low speeds [3 MPH (4.8 km/h) or less] or high speeds [90 MPH (144 km/h) or more].
  - Intelligent cruise control is in operation.
  - Selector lever is in R range.

#### ENGINE OUTPUT CHARACTERISTICS AFTER SWITCHING MODE

- Engine output characteristics after switching mode by operating the drive mode select switch are as follows.
  - After switching mode to a mode that engine output increase, engine output characteristics are changed by releasing the accelerator pedal.
  - After switching mode to a mode that engine output decreases, engine output characteristics are changed immediately.
- When an accelerator angle is constant, engine output characteristics are as follows.
  - SPORT > STANDARD > ECO > SNOW

Output characteristics of each mode

| Control mode | Engine output                           |
|--------------|---|
| SPORT        | Increase                                |
| STANDARD     | Normal                                  |
| ECO          | Decrease                                |
| SNOW         | Decrease (More reduction than ECO mode) |

A  
EC  
C  
D  
E  
F  
G  
H  
I  
J  
K  
L  
M  
N  
O  
P

# ON BOARD DIAGNOSTIC (OBD) SYSTEM

< SYSTEM DESCRIPTION >

[VQ37VHR FOR MEXICO]

## ON BOARD DIAGNOSTIC (OBD) SYSTEM

### Diagnosis Description

INFOID:000000007729696

This system is an on board diagnostic system that records exhaust emission-related diagnostic information and detects a sensors/actuator-related malfunction. A malfunction is indicated by the malfunction indicator lamp (MIL) and stored in ECU memory as a DTC. The diagnostic information can be obtained with the diagnostic tool (GST: Generic Scan Tool).

### GST (Generic Scan Tool)

INFOID:000000007729697

When GST is connected with a data link connector equipped on the vehicle side, it will communicate with the control unit equipped in the vehicle and then enable various kinds of diagnostic tests. Refer to [EC-590, "Diagnosis Description"](#).

**NOTE:**

Service \$0A is not applied for regions where it is not mandated.

## DIAGNOSIS SYSTEM (ECM)

### DIAGNOSIS DESCRIPTION

#### DIAGNOSIS DESCRIPTION : 1st Trip Detection Logic and Two Trip Detection Logic

INFOID:000000007729698

When a malfunction is detected for the first time, 1st trip DTC and 1st trip Freeze Frame data are stored in the ECM memory. The MIL will not illuminate at this stage. <1st trip>

If the same malfunction is detected again during the next drive, the DTC and Freeze Frame data are stored in the ECM memory, and the MIL illuminates. The MIL illuminates at the same time when the DTC is stored. <2nd trip> The "trip" in the "Two Trip Detection Logic" means a driving mode in which self-diagnosis is performed during vehicle operation. Specific on board diagnostic items will cause the ECM to illuminate or blink the MIL, and store DTC and Freeze Frame data, even in the 1st trip, as shown below.

x: Applicable —: Not applicable

| Items   | MIL      |            |          |            | DTC                 |                     | 1st trip DTC        |                     |
|---|----------|------------|----------|------------|---------------------|---------------------|---------------------|---------------------|
|   | 1st trip |            | 2nd trip |            | 1st trip displaying | 2nd trip displaying | 1st trip displaying | 2nd trip displaying |
|   | Blinking | Illuminate | Blinking | Illuminate |                     |                     |                     |                     |
| Misfire (Possible three way catalyst damage) — DTC: P0300 - P0308 is being detected | x        | —          | —        | —          | —                   | —                   | x                   | —                   |
| Misfire (Possible three way catalyst damage) — DTC: P0300 - P0308 is being detected | —        | —          | x        | —          | —                   | x                   | —                   | —                   |
| One trip detection diagnoses (Refer to <a href="#">EC-628, "DTC Index"</a> .)       | —        | x          | —        | —          | x                   | —                   | —                   | —                   |
| Except above  | —        | —          | —        | x          | —                   | x                   | x                   | —                   |

#### DIAGNOSIS DESCRIPTION : DTC and Freeze Frame Data

INFOID:000000007729699

##### DTC AND 1ST TRIP DTC

The 1st trip DTC (whose number is the same as the DTC number) is displayed for the latest self-diagnostic result obtained. If the ECM memory was cleared previously, and the 1st trip DTC did not recur, the 1st trip DTC will not be displayed.

If a malfunction is detected during the 1st trip, the 1st trip DTC is saved in the ECM memory. The MIL will not light up (two trip detection logic). If the same malfunction is not detected in the 2nd trip (meeting the required driving pattern), the 1st trip DTC is cleared from the ECM memory. If the same malfunction is detected in the 2nd trip, both the 1st trip DTC and DTC are saved in the ECM memory and the MIL lights up. In other words, the DTC is stored in the ECM memory and the MIL lights up when the same malfunction occurs in two consecutive trips. If a 1st trip DTC is stored and a non-diagnostic operation is performed between the 1st and 2nd trips, only the 1st trip DTC will continue to be stored. For malfunctions that blink or light up the MIL during the 1st trip, the DTC and 1st trip DTC are stored in the ECM memory.

For malfunctions in which 1st trip DTCs are displayed, refer to [EC-628, "DTC Index"](#). These items are required by legal regulations to continuously monitor the system/component. In addition, the items monitored non-continuously are also displayed on CONSULT.

1st trip DTC is specified in Service \$07 of SAE J1979/ISO 15031-5. 1st trip DTC detection occurs without illuminating the MIL and therefore does not warn the driver of a malfunction.

When a 1st trip DTC is detected, check, print out or write down and erase (1st trip) DTC and Freeze Frame data as specified in Work Flow procedure Step 2, refer to [EC-649, "Work Flow"](#). Then perform DTC Confirmation Procedure or Component Function Check to try to duplicate the malfunction. If the malfunction is duplicated, the item requires repair.

##### FREEZE FRAME DATA AND 1ST TRIP FREEZE FRAME DATA

The ECM records the driving conditions such as fuel system status, calculated load value, engine coolant temperature, short term fuel trim, long term fuel trim, engine speed, vehicle speed, absolute throttle position, base fuel schedule and intake air temperature at the moment a malfunction is detected.

Data which are stored in the ECM memory, along with the 1st trip DTC, are called 1st trip freeze frame data. The data, stored together with the DTC data, are called freeze frame data and displayed on CONSULT or GST. The 1st trip freeze frame data can only be displayed on the CONSULT screen.

# DIAGNOSIS SYSTEM (ECM)

[VQ37VHR FOR MEXICO]

## < SYSTEM DESCRIPTION >

Only one set of freeze frame data (either 1st trip freeze frame data or freeze frame data) can be stored in the ECM. 1st trip freeze frame data is stored in the ECM memory along with the 1st trip DTC. There is no priority for 1st trip freeze frame data and it is updated each time a different 1st trip DTC is detected. However, once freeze frame data (2nd trip detection/MIL on) is stored in the ECM memory, 1st trip freeze frame data is no longer stored. Remember, only one set of freeze frame data can be stored in the ECM. The ECM has the following priorities to update the data.

| Priority | Items                      |  |
|----------|----------------------------|--|
| 1        | Freeze frame data          | Misfire — DTC: P0300 - P0308<br>Fuel Injection System Function — DTC: P0171, P0172, P0174, P0175 |
| 2        |                            | Except the above items   |
| 3        | 1st trip freeze frame data |  |

For example, the EGR malfunction (Priority: 2) was detected and the freeze frame data was saved in the 2nd trip. After that when the misfire (Priority: 1) is detected in another trip, the freeze frame data will be updated from the EGR malfunction to the misfire. The 1st trip freeze frame data is updated each time a different malfunction is detected. There is no priority for 1st trip freeze frame data. However, once freeze frame data is stored in the ECM memory, 1st trip freeze data is no longer stored (because only one freeze frame data or 1st trip freeze frame data can be stored in the ECM). If freeze frame data is stored in the ECM memory and freeze frame data with the same priority occurs later, the first (original) freeze frame data remains unchanged in the ECM memory.

Both 1st trip freeze frame data and freeze frame data (along with the DTCs) are cleared when the ECM memory is erased.

## DIAGNOSIS DESCRIPTION : Counter System

INFOID:000000007729700

### RELATIONSHIP BETWEEN MIL, 1ST TRIP DTC, DTC, AND DETECTABLE ITEMS

- When a malfunction is detected for the first time, the 1st trip DTC and the 1st trip freeze frame data are stored in the ECM memory.
- When the same malfunction is detected in two consecutive trips, the DTC and the freeze frame data are stored in the ECM memory, and the MIL will come on.
- The MIL will turn OFF after the vehicle is driven 3 times (driving pattern B) with no malfunction. The drive is counted only when the recorded driving pattern is met (as stored in the ECM). If another malfunction occurs while counting, the counter will reset.
- The DTC and the freeze frame data will be stored until the vehicle is driven 40 times (driving pattern A) without the same malfunction recurring (except for Misfire and Fuel Injection System). For Misfire and Fuel Injection System, the DTC and freeze frame data will be stored until the vehicle is driven 80 times (driving pattern C) without the same malfunction recurring. The "TIME" in "SELF-DIAGNOSTIC RESULTS" mode of CONSULT will count the number of times the vehicle is driven.
- The 1st trip DTC is not displayed when the self-diagnosis results in OK for the 2nd trip.

### COUNTER SYSTEM CHART

| Items                               | Fuel Injection System | Misfire           | Other          |
|-------------------------------------|-----------------------|-------------------|----------------|
| MIL (turns OFF)                     | 3 (pattern B)         | 3 (pattern B)     | 3 (pattern B)  |
| DTC, Freeze Frame Data (no display) | 80 (pattern C)        | 80 (pattern C)    | 40 (pattern A) |
| 1st Trip DTC (clear)                | 1 (pattern C), *1     | 1 (pattern C), *1 | 1 (pattern B)  |
| 1st Trip Freeze Frame Data (clear)  | *1, *2                | *1, *2            | 1 (pattern B)  |

For details about patterns B and C under "Fuel Injection System" and "Misfire", see "EXPLANATION FOR DRIVING PATTERNS FOR "MISFIRE <EXHAUST QUALITY DETERIORATION>", "FUEL INJECTION SYSTEM".

For details about patterns A and B under Other, see "EXPLANATION FOR DRIVING PATTERNS FOR "MISFIRE <EXHAUST QUALITY DETERIORATION>", "FUEL INJECTION SYSTEM".

- \*1: Clear timing is at the moment OK is detected.
- \*2: Clear timing is when the same malfunction is detected in the 2nd trip.

Relationship Between MIL, DTC, 1st Trip DTC and Driving Patterns for "Misfire <Exhaust Quality Deterioration>", "Fuel Injection System"



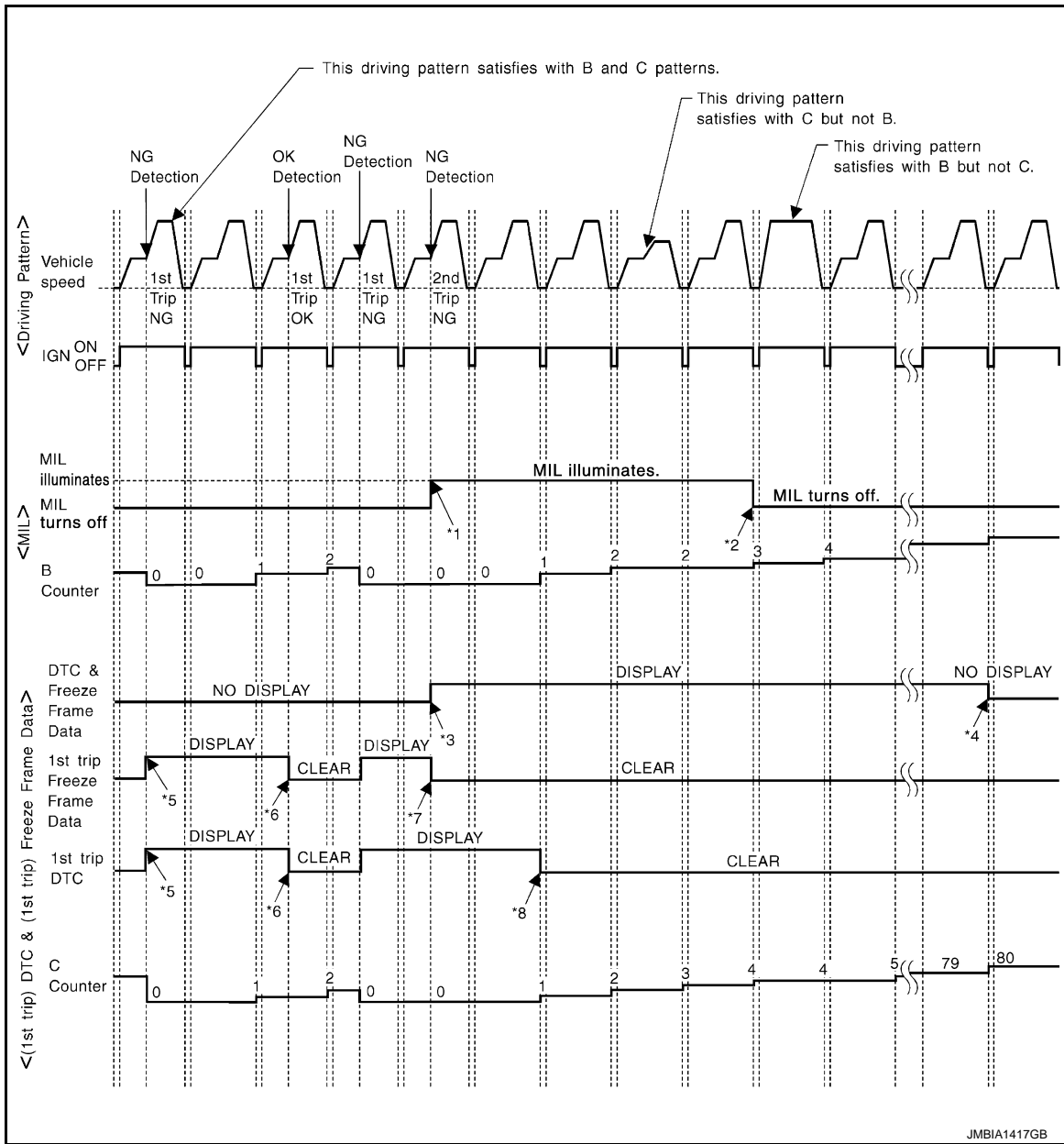

\*1: When the same malfunction is detected in two consecutive trips, MIL will light up.

\*2: MIL will turn OFF after vehicle is driven 3 times (pattern B) without any malfunctions.

\*3: When the same malfunction is detected in two consecutive trips, the DTC and the freeze frame data will be stored in ECM.

\*4: The DTC and the freeze frame data will not be displayed any longer after vehicle is driven 80 times (pattern C) without the same malfunction. (The DTC and the freeze frame data still remain in ECM.)

\*5: When a malfunction is detected for the first time, the 1st trip DTC and the 1st trip freeze frame data will be stored in ECM.

\*6: The 1st trip DTC and the 1st trip freeze frame data will be cleared at the moment OK is detected.

\*7: When the same malfunction is detected in the 2nd trip, the 1st trip freeze frame data will be cleared.

\*8: 1st trip DTC will be cleared when vehicle is driven once (pattern C) without the same malfunction after DTC is stored in ECM.

## Explanation for Driving Patterns for "Misfire <Exhaust Quality Deterioration>", "Fuel Injection System"

### Driving Pattern B

Refer to [EC-595. "DIAGNOSIS DESCRIPTION : Driving Pattern"](#).

# DIAGNOSIS SYSTEM (ECM)

[VQ37VHR FOR MEXICO]

## < SYSTEM DESCRIPTION >

### Driving Pattern C

Refer to [EC-595. "DIAGNOSIS DESCRIPTION : Driving Pattern"](#).

Example:

If the stored freeze frame data is as per the following:

Engine speed: 850 rpm, Calculated load value: 30%, Engine coolant temperature: 80°C (176°F)

To be satisfied with driving pattern C, the vehicle should run under the following conditions:

Engine speed: 475 – 1,225 rpm, Calculated load value: 27 – 33%, Engine coolant temperature: more than 70°C (158°F)

Relationship Between MIL, DTC, 1st Trip DTC and Driving Patterns Except For “Misfire <Exhaust Quality Deterioration>”, “Fuel Injection System”

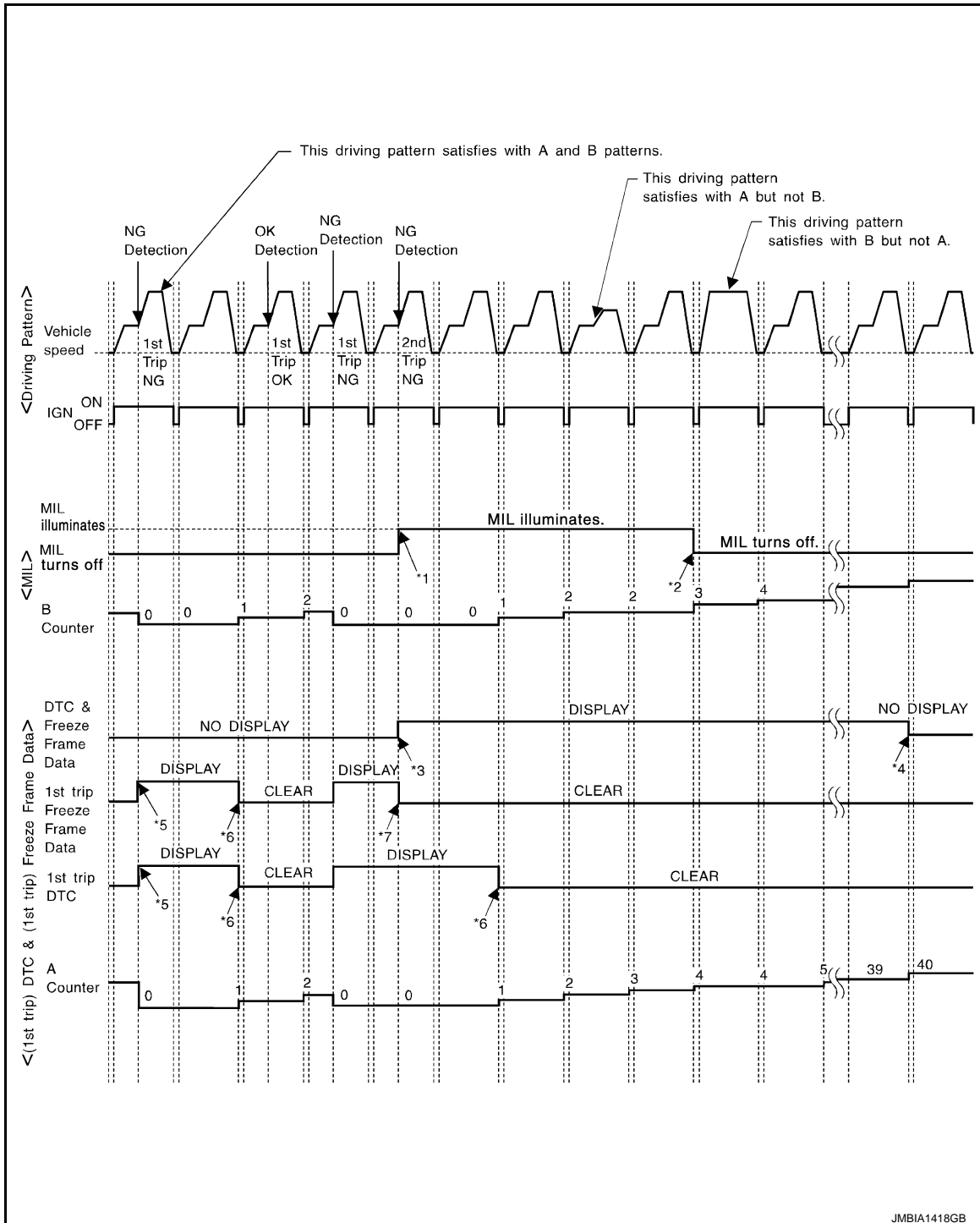

JMBIA1418GB

< SYSTEM DESCRIPTION >

- |   |  |   |    |
|---|--|---|----|
| <p>*1: When the same malfunction is detected in two consecutive trips, MIL will light up.</p>   | <p>*2: MIL will turn OFF after vehicle is driven 3 times (pattern B) without any malfunctions.</p>                                       | <p>*3: When the same malfunction is detected in two consecutive trips, the DTC and the freeze frame data will be stored in ECM.</p> | A  |
| <p>*4: The DTC and the freeze frame data will not be displayed any longer after vehicle is driven 40 times (pattern A) without the same malfunction.<br/>(The DTC and the freeze frame data still remain in ECM.)</p> | <p>*5: When a malfunction is detected for the first time, the 1st trip DTC and the 1st trip freeze frame data will be stored in ECM.</p> | <p>*6: 1st trip DTC will be cleared after vehicle is driven once (pattern B) without the same malfunction.</p>                      | EC |
| <p>*7: When the same malfunction is detected in the 2nd trip, the 1st trip freeze frame data will be cleared.</p>   |  |   | C  |

Explanation for Driving Patterns Except for “Misfire <Exhaust Quality Deterioration>”, “Fuel Injection System”

Driving Pattern A

Refer to [EC-595, "DIAGNOSIS DESCRIPTION : Driving Pattern"](#).

Driving Pattern B

Refer to [EC-595, "DIAGNOSIS DESCRIPTION : Driving Pattern"](#).

## DIAGNOSIS DESCRIPTION : Driving Pattern

INFOID:000000007729702

**CAUTION:**

**Always drive at a safe speed.**

### DRIVING PATTERN A

Driving pattern A means a trip satisfying the following conditions.

- Engine speed reaches 400 rpm or more.
- Engine coolant temperature rises by 20°C (32°F) or more after starting the engine.
- Engine coolant temperature reaches 70°C (158°F) or more.
- The ignition switch is turned from ON to OFF.

**NOTE:**

- When the same malfunction is detected regardless of driving conditions, reset the counter of driving pattern A.
- When the above conditions are satisfied without detecting the same malfunction, reset the counter of driving pattern A.

### DRIVING PATTERN B

Driving pattern B means a trip satisfying the following conditions.

- Engine speed reaches 400 rpm or more.
- Engine coolant temperature reaches 70°C (158°F) or more.
- Vehicle speed of 70 – 120 km/h (44 – 75 MPH) is maintained for 60 seconds or more under the control of closed loop.
- Vehicle speed of 30 – 60 km/h (19 – 37 MPH) is maintained for 10 seconds or more under the control of closed loop.
- Under the closed loop control condition, the following state reaches 12 seconds or more in total: Vehicle speed of 4 km/h (2 MPH) or less with idling condition.
- The state of driving at 10 km/h (7 MPH) or more reaches 10 minutes or more in total.
- A lapse of 22 minutes or more after engine start.

**NOTE:**

- Drive the vehicle at a constant velocity.
- When the same malfunction is detected regardless of driving conditions, reset the counter of driving pattern B.
- When the above conditions are satisfied without detecting the same malfunction, reset the counter of driving pattern B.

### DRIVING PATTERN C

Driving pattern C means operating vehicle as per the following:

The following conditions should be satisfied at the same time:

Engine speed: (Engine speed in the freeze frame data) ±375 rpm

# DIAGNOSIS SYSTEM (ECM)

[VQ37VHR FOR MEXICO]

## < SYSTEM DESCRIPTION >

Calculated load value: (Calculated load value in the freeze frame data) x (1±0.1) [%]

Engine coolant temperature condition:

- When the freeze frame data shows lower than 70°C (158°F), engine coolant temperature should be lower than 70°C (158°F).
- When the freeze frame data shows higher than or equal to 70°C (158°F), engine coolant temperature should be higher than or equal to 70°C (158°F).

### NOTE:

- When the same malfunction is detected regardless of the above vehicle conditions, reset the counter of driving pattern C.
- When the above conditions are satisfied without detecting the same malfunction, reset the counter of driving pattern C.
- The 1st trip DTC will be cleared when C counter is counted once without the same malfunction after DTC is stored in ECM.

## DRIVING PATTERN D

Driving pattern D means a trip satisfying the following conditions.

- The state of driving at 40 km/h (25 MPH) reaches 300 seconds or more in total.
- Idle speed lasts 30 seconds or more.
- A lapse of 600 seconds or more after engine start.

### NOTE:

- When the same malfunction is detected regardless of driving conditions, reset the counter of driving pattern D.
- When the above conditions are satisfied without detecting the same malfunction, reset the counter of driving pattern D.

## DIAGNOSIS DESCRIPTION : System Readiness Test (SRT) Code

INFOID:000000007729704

System Readiness Test (SRT) code is specified in Service \$01 of SAE J1979/ISO 15031-5.

As part of an enhanced emissions test for Inspection & Maintenance (I/M), certain states require the status of SRT be used to indicate whether the ECM has completed self-diagnosis of major emission systems and components. Completion must be verified in order for the emissions inspection to proceed.

If a vehicle is rejected for a State emissions inspection due to one or more SRT items indicating "INCMP", use the information in this Service Manual to set the SRT to "CMPLT".

In most cases the ECM will automatically complete its self-diagnosis cycle during normal usage, and the SRT status will indicate "CMPLT" for each application system. Once set as "CMPLT", the SRT status remains "CMPLT" until the self-diagnosis memory is erased.

Occasionally, certain portions of the self-diagnostic test may not be completed as a result of the customer's normal driving pattern; the SRT will indicate "INCMP" for these items.

### NOTE:

The SRT will also indicate "INCMP" if the self-diagnosis memory is erased for any reason or if the ECM memory power supply is interrupted for several hours.

If, during the state emissions inspection, the SRT indicates "CMPLT" for all test items, the inspector will continue with the emissions test. However, if the SRT indicates "INCMP" for one or more of the SRT items the vehicle is returned to the customer untested.

### NOTE:

If MIL is ON during the state emissions inspection, the vehicle is also returned to the customer untested even though the SRT indicates "CMPLT" for all test items. Therefore, it is important to check SRT ("CMPLT") and DTC (No DTCs) before the inspection.

## SRT SET TIMING

SRT is set as "CMPLT" after self-diagnosis has been performed one or more times. Completion of SRT is done regardless of whether the result is OK or NG. The set timing is different between OK and NG results and is shown in the table below.

# DIAGNOSIS SYSTEM (ECM)

< SYSTEM DESCRIPTION >

[VQ37VHR FOR MEXICO]

| Self-diagnosis result |        | Example           |                |         |              |                        |     |        |
|-----------------------|--------|-------------------|----------------|---------|--------------|------------------------|-----|--------|
|                       |        | Diagnosis         | Ignition cycle |         |              |                        |     |        |
|                       | ← ON → |                   | OFF            | ← ON →  | OFF          | ← ON →                 | OFF | ← ON → |
| All OK                | Case 1 | P0400             | OK (1)         | — (1)   | OK (2)       | — (2)                  |     |        |
|                       |        | P0402             | OK (1)         | — (1)   | — (1)        | OK (2)                 |     |        |
|                       |        | P1402             | OK (1)         | OK (2)  | — (2)        | — (2)                  |     |        |
|                       |        | SRT of EGR        | "CMPLT"        | "CMPLT" | "CMPLT"      | "CMPLT"                |     |        |
|                       | Case 2 | P0400             | OK (1)         | — (1)   | — (1)        | — (1)                  |     |        |
|                       |        | P0402             | — (0)          | — (0)   | OK (1)       | — (1)                  |     |        |
|                       |        | P1402             | OK (1)         | OK (2)  | — (2)        | — (2)                  |     |        |
|                       |        | SRT of EGR        | "INCMP"        | "INCMP" | "CMPLT"      | "CMPLT"                |     |        |
| NG exists             | Case 3 | P0400             | OK             | OK      | —            | —                      |     |        |
|                       |        | P0402             | —              | —       | —            | —                      |     |        |
|                       |        | P1402             | NG             | —       | NG           | NG<br>(Consecutive NG) |     |        |
|                       |        | (1st trip)<br>DTC | 1st trip DTC   | —       | 1st trip DTC | DTC<br>(= MIL ON)      |     |        |
|                       |        | SRT of EGR        | "INCMP"        | "INCMP" | "INCMP"      | "CMPLT"                |     |        |

OK: Self-diagnosis is carried out and the result is OK.

NG: Self-diagnosis is carried out and the result is NG.

—: Self-diagnosis is not carried out.

When all SRT related self-diagnoses show OK results in a single cycle (Ignition OFF-ON-OFF), the SRT will indicate "CMPLT". → Case 1 above

When all SRT related self-diagnoses show OK results through several different cycles, the SRT will indicate "CMPLT" at the time the respective self-diagnoses have at least one OK result. → Case 2 above

If one or more SRT related self-diagnoses show NG results in 2 consecutive cycles, the SRT will also indicate "CMPLT". → Case 3 above

The table above shows that the minimum number of cycles for setting SRT as "INCMP" is the number one (1) for each self-diagnosis (Case 1 & 2) or the number two (2) for one of self-diagnoses (Case 3). However, in preparation for the state emissions inspection, it is unnecessary for each self-diagnosis to be executed twice (Case 3) for the following reasons:

- The SRT will indicate "CMPLT" at the time the respective self-diagnoses have one (1) OK result.
- The emissions inspection requires "CMPLT" of the SRT only with OK self-diagnosis results.
- During SRT driving pattern, the 1st trip DTC (NG) is detected prior to "CMPLT" of SRT and the self-diagnosis memory must be erased from the ECM after repair.
- If the 1st trip DTC is erased, all the SRT will indicate "INCMP".

**NOTE:**

SRT can be set as "CMPLT" together with the DTC(s). Therefore, DTC check must always be carried out prior to the state emission inspection even though the SRT indicates "CMPLT".

## DIAGNOSIS DESCRIPTION : Malfunction Indicator Lamp (MIL)

INFOID:000000007729707

When emission related ECU detects a malfunction in the emission control systems components and/or the powertrain control components (which affect vehicle emissions), it turns on/blinks MIL to inform the driver that a malfunction has been detected.

1. The MIL illuminates when ignition switch is turned ON (engine is not running).

**NOTE:**

Check the MIL circuit if MIL does not illuminate. Refer to [EC-957. "Component Function Check"](#).

2. When the engine is started, the MIL should go off.

**NOTE:**

If MIL continues to illuminate/blink, perform self-diagnoses and inspect/repair accordingly because an emission related ECU has detected a malfunction in the emission control systems components and/or the powertrain control components (which affect vehicle emissions).

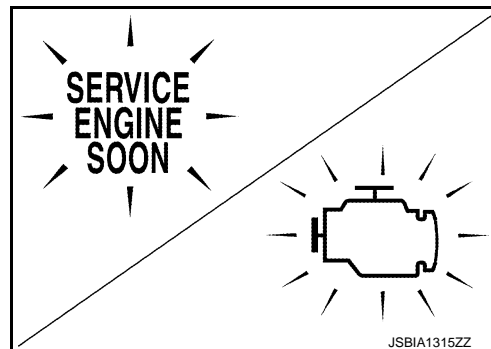

JSBIA1315ZZ

## On Board Diagnosis Function

INFOID:000000007729708

### ON BOARD DIAGNOSIS ITEM

The on board diagnostic system has the following functions.

| Diagnostic test mode                          | Function   |
|---|--|
| Bulb check                                    | MIL can be checked.  |
| SRT status                                    | ECM can read if SRT codes are set.   |
| Malfunction warning                           | If ECM detects a malfunction, it illuminates or blinks MIL to inform the driver that a malfunction has been detected.            |
| Self-diagnostic results                       | DTCs or 1st trip DTCs stored in ECM can be read.   |
| Accelerator pedal released position learning  | ECM can learn the accelerator pedal released position. Refer to <a href="#">EC-656, "Description"</a> .                          |
| Throttle valve closed position learning       | ECM can learn the throttle valve closed position. Refer to <a href="#">EC-656, "Description"</a> .                               |
| Idle air volume learning                      | ECM can learn the idle air volume. Refer to <a href="#">EC-658, "Description"</a> .  |
| VVEL control shaft position sensor adjustment | The initial position of the VVEL control shaft position sensor can be adjusted. Refer to <a href="#">EC-660, "Description"</a> . |

### BLUB CHECK MODE

#### Description

This function allows damage inspection in the MIL bulb (blown, open circuit, etc.).

#### Operation Procedure

1. Turn ignition switch ON.
2. The MIL on the instrument panel should stay ON.  
If it remains OFF, check MIL circuit. Refer to [EC-957, "Diagnosis Procedure"](#).

### SRT STATUS MODE

#### Description

This function allows to read if ECM has completed the self-diagnoses of major emission control systems and components. For SRT, refer to [EC-596, "DIAGNOSIS DESCRIPTION : System Readiness Test \(SRT\) Code"](#).

#### Operation Procedure

1. Turn ignition switch ON and wait 20 seconds.
2. SRT status is indicated as shown blow.
  - ECM continues to illuminate MIL if all SRT codes are set.
  - ECM blinks MIL for about 10 seconds if all SRT codes are not set.

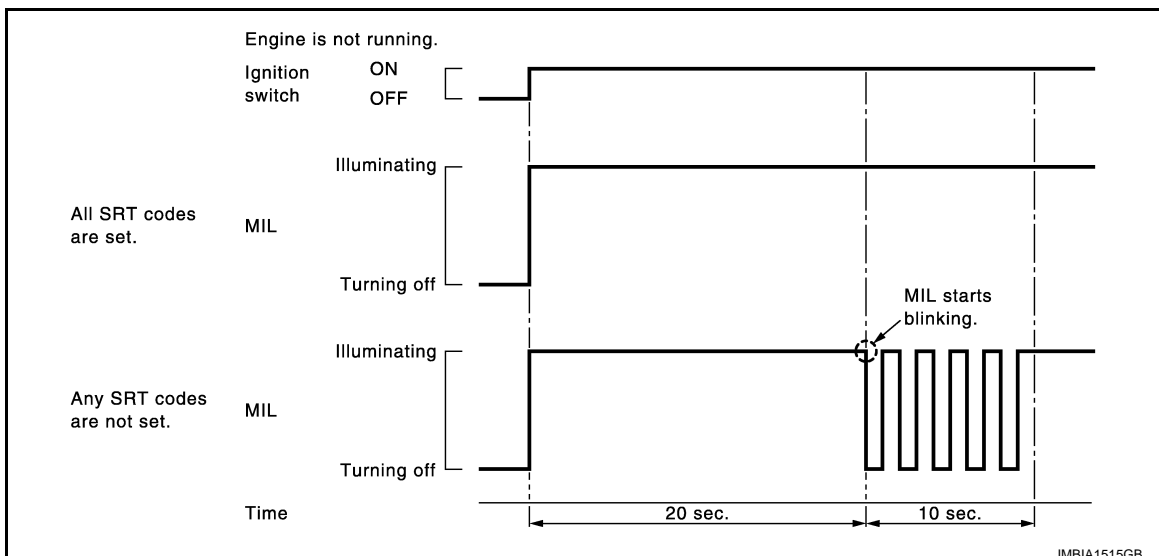

JMBIA1515GB

## MALFUNCTION WARNING MODE

### Description

In this function ECM turns on or blinks MIL when it detects a malfunction in the emission control system components and/or the powertrain control components (which affect vehicle emissions) to inform the driver that a malfunction has been detected.

### Operation Procedure

1. Turn ignition switch ON.
2. Check that MIL illuminates.  
If it remains OFF, check MIL circuit. Refer to [EC-957. "Diagnosis Procedure"](#).
3. Start engine and let it idle.
  - For two trip detection logic diagnoses, ECM turns on MIL when it detects the same malfunction twice in the two consecutive driving cycles.
  - For 1st trip detection logic diagnoses, ECM turns on MIL when it detects a malfunction in one driving cycle.
  - ECM blinks MIL when it detects a malfunction that may damage the three way catalyst (misfire).

## SELF-DIAGNOSTIC RESULTS MODE

### Description

This function allows to indicate DTCs or 1st trip DTCs stored in ECM according to the number of times MIL is blinking.

### How to Set Self-diagnostic Results Mode

#### NOTE:

- It is better to count the time accurately with a clock.
  - It is impossible to switch the diagnostic mode when an accelerator pedal position sensor circuit has a malfunction.
  - After ignition switch is turned off, ECM is always released from the "self-diagnostic results" mode.
1. Confirm that accelerator pedal is fully released, turn ignition switch ON and wait 3 seconds.
  2. Repeat the following procedure quickly five times within 5 seconds.
    - Fully depress the accelerator pedal.
    - Fully release the accelerator pedal.
  3. Wait 7 seconds, fully depress the accelerator pedal and keep it depressed for approx. 10 seconds until the MIL starts blinking.

#### NOTE:

Do not release the accelerator pedal for 10 seconds if MIL starts blinking during this period. This blinking is displaying SRT status and is continued for another 10 seconds.

4. Fully release the accelerator pedal.  
ECM has entered to self-diagnostic results mode.

#### NOTE:

Wait until the same DTC (or 1st trip DTC) appears to completely confirm all DTCs.

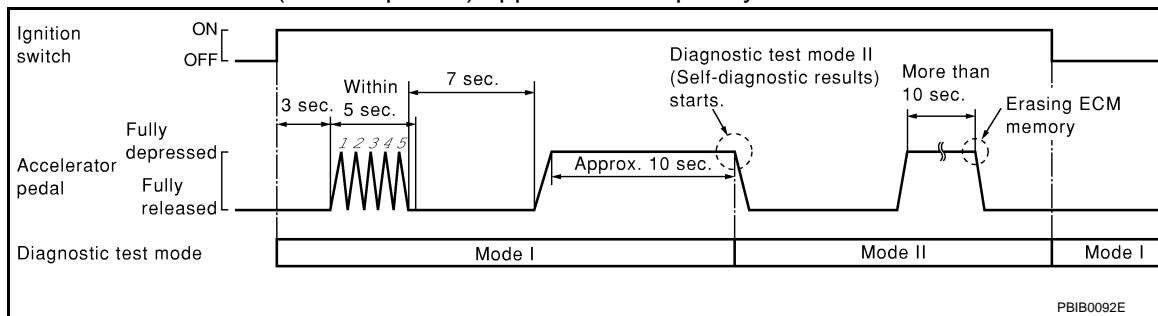

### How to Read Self-diagnostic Results

The DTC and 1st trip DTC are indicated by the number of blinks of the MIL as shown below. The DTC and 1st trip DTC are displayed at the same time. If the MIL does not illuminate in diagnostic test mode I (Malfunction warning), all displayed items are 1st trip DTCs. If only one code is displayed when the MIL illuminates in "malfunction warning" mode, it is a DTC; if two or more codes are displayed, they may be either

# DIAGNOSIS SYSTEM (ECM)

< SYSTEM DESCRIPTION >

[VQ37VHR FOR MEXICO]

DTCs or 1st trip DTCs. DTC No. is same as that of 1st trip DTC. These unidentified codes can be identified by using the CONSULT or GST. A DTC will be used as an example for how to read a code.

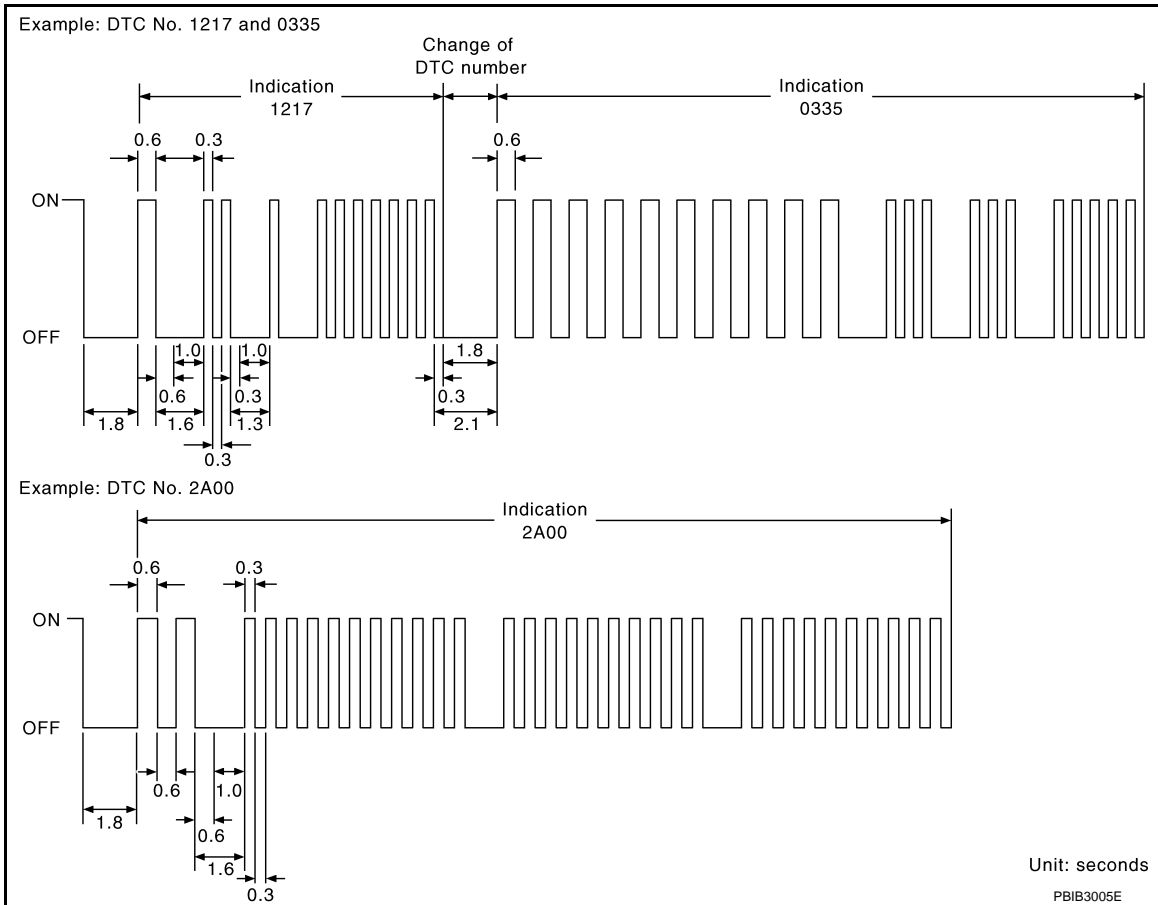

A particular trouble code can be identified by the number of four-digit numeral flashes per the following.

| Number  | 0  | 1 | 2 | 3 | 4 | 5 | 6 | 7 | 8 | 9 | A  | B  | C  | D  | E  | F  |
|---------|----|---|---|---|---|---|---|---|---|---|----|----|----|----|----|----|
| Flashes | 10 | 1 | 2 | 3 | 4 | 5 | 6 | 7 | 8 | 9 | 11 | 12 | 13 | 14 | 15 | 16 |

The length of time the 1,000th-digit numeral flashes on and off is 1.2 seconds consisting of an ON (0.6-seconds) - OFF (0.6-seconds) cycle.

The 100th-digit numeral and lower digit numerals consist of a 0.3-seconds ON and 0.3-seconds OFF cycle.

A change from one digit numeral to another occurs at an interval of 1.0-second OFF. In other words, the later numeral appears on the display 1.3 seconds after the former numeral has disappeared.

A change from one trouble code to another occurs at an interval of 1.8-seconds OFF.

In this way, all the detected malfunctions are classified by their DTC numbers. The DTC 0000 refers to no malfunction. Refer to [EC-628, "DTC Index"](#).

## How to Erase Self-diagnostic Results

By performing this procedure, ECM memory is erased and the following diagnostic information is erased as well.

- Diagnostic trouble codes
- 1st trip diagnostic trouble codes
- Freeze frame data
- 1st trip freeze frame data
- System readiness test (SRT) codes
- Test values

### NOTE:

Also, if a battery terminal is disconnected, ECM memory is erased and the diagnostic information as listed above is erased. (The amount of time required for erasing may vary from a few seconds to several hours.)

1. Turn ignition switch OFF and wait at least 10 seconds.
2. Turn ignition switch ON.
3. Turn ignition switch OFF and wait at least 10 seconds.



# DIAGNOSIS SYSTEM (ECM)

[VQ37VHR FOR MEXICO]

## < SYSTEM DESCRIPTION >

4. Turn ignition switch ON.
5. Set ECM in self-diagnostic results.
6. The diagnostic information has been erased from the backup memory in the ECM.  
Fully depress the accelerator pedal and keep it depressed for more than 10 seconds.
7. Fully release the accelerator pedal, and confirm the DTC 0000 is displayed.

## CONSULT Function

INFOID:00000000729709

### FUNCTION

| Diagnostic test mode           | Function  |
|--------------------------------|---|
| Work support                   | This mode enables a technician to adjust some devices faster and more accurately by following the indications on the CONSULT unit.      |
| Self-diagnostic results        | Self-diagnostic results such as 1st trip DTC, DTCs and 1st trip freeze frame data or freeze frame data can be read and erased quickly.* |
| Data monitor                   | Input/Output data in the ECM can be read.   |
| CAN diagnostic support monitor | The results of transmit/receive diagnosis of CAN communication can be read.   |
| Active test                    | Diagnostic Test Mode in which CONSULT drives some actuators apart from the ECMs and also shifts some parameters in a specified range.   |
| DTC & SRT confirmation         | The status of system monitoring tests and the self-diagnosis status/results can be confirmed.   |
| Function test                  | This mode is used to inform customers when their vehicle requires periodic maintenance.   |
| ECU part number                | ECM part number can be read.  |

\*: The following emission-related diagnostic information is cleared when the ECM memory is erased.

- Diagnostic trouble codes
- 1st trip diagnostic trouble codes
- Freeze frame data
- 1st trip freeze frame data
- System readiness test (SRT) codes
- Test values

### WORK SUPPORT MODE

#### Work Item

| WORK ITEM             | CONDITION  | USAGE   |
|-----------------------|--|---|
| IDLE AIR VOL LEARN    | <ul style="list-style-type: none"> <li>• The idle air volume that keeps the engine within the specified range is memorized in ECM.</li> </ul>  | When learning the idle air volume                 |
| EVAP SYSTEM CLOSE     | Close the EVAP canister vent control valve in order to make evap system close under the following conditions. <ul style="list-style-type: none"> <li>• Ignition switch ON</li> <li>• Engine not running</li> <li>• Ambient temperature is above 0°C (32°F).</li> <li>• No vacuum and no high pressure in EVAP system</li> <li>• Fuel tank temp. is more than 0°C (32°F).</li> <li>• Within 10 minutes after starting "EVAP SYSTEM CLOSE"</li> <li>• When trying to execute "EVAP SYSTEM CLOSE" Under the condition except above, CONSULT will discontinue it and display appropriate instruction.</li> </ul> <b>NOTE:</b><br><b>When starting engine, CONSULT may display "Battery voltage is low. Charge battery", even when using a charged battery.</b> | When detecting EVAP vapor leak in the EVAP system |
| FUEL PRESSURE RELEASE | <ul style="list-style-type: none"> <li>• Fuel pump will stop by touching "START" during idling. Crank a few times after engine stalls.</li> </ul>  | When releasing fuel pressure from fuel line       |
| SELF-LEARNING CONT    | <ul style="list-style-type: none"> <li>• The coefficient of self-learning control mixture ratio returns to the original coefficient.</li> </ul>  | When clearing mixture ratio self-learning value   |
| TARGET IDLE RPM ADJ*  | <ul style="list-style-type: none"> <li>• Idle condition</li> </ul>   | When setting target idle speed                    |

# DIAGNOSIS SYSTEM (ECM)

< SYSTEM DESCRIPTION >

[VQ37VHR FOR MEXICO]

| WORK ITEM             | CONDITION  | USAGE   |
|-----------------------|--|---|
| TARGET IGN TIM ADJ*   | <ul style="list-style-type: none"> <li>Idle condition</li> </ul>   | When adjusting target ignition timing             |
| VIN REGISTRATION      | <ul style="list-style-type: none"> <li>In this mode, VIN is registered in ECM.</li> </ul>  | When registering VIN in ECM                       |
| CLSD THL POS LEARN    | <ul style="list-style-type: none"> <li>Ignition switch ON and engine stopped.</li> </ul>   | When learning the throttle valve closed position  |
| VVEL POS SEN ADJ PREP | <ul style="list-style-type: none"> <li>Use this item only when replacing VVEL actuator sub assembly.</li> <li>Ignition on and engine stopped.</li> </ul> | When adjusting VVEL control shaft position sensor |

\*: This function is not necessary in the usual service procedure.

## SELF-DIAG RESULTS MODE

Self Diagnostic Item

Regarding items of DTC and 1st trip DTC, refer to [EC-628, "DTC Index"](#).

How to Read DTC and 1st Trip DTC

DTCs and 1st trip DTCs related to the malfunction are displayed in "Self-diag results".

- When ECM detects a 1st trip DTC, "1t" is displayed for "TIME".
- When ECM has detected a current DTC, "0" is displayed for "TIME".
- If "TIME" is neither "0" nor "1t", the DTC occurred in the past and ECM shows the number of times the vehicle has been driven since the last detection of the DTC.

How to Erase DTC and 1st Trip DTC

### NOTE:

- If the ignition switch stays ON after repair work, be sure to turn ignition switch OFF once. Wait at least 10 seconds and then turn it ON (engine stopped) again.
- If the DTC is not for A/T related items (see [EC-628, "DTC Index"](#)), skip step 1.
  - Erase DTC in TCM. Refer to [TM-59, "Diagnosis Description"](#).
  - Select "ENGINE" with CONSULT.
  - Select "SELF-DIAG RESULTS".
  - Touch "ERASE". (DTC in ECM will be erased.)

Freeze Frame Data and 1st Trip Freeze Frame Data

| Freeze frame data item*      | Description   |
|------------------------------|---|
| DIAG TROUBLE CODE [PXXXX]    | <ul style="list-style-type: none"> <li>The engine control component part/control system has a trouble code that is displayed as PXXXX. (Refer to <a href="#">EC-628, "DTC Index"</a>.)</li> </ul>   |
| CAL/LD VALUE [%]             | <ul style="list-style-type: none"> <li>The calculated load value at the moment a malfunction is detected is displayed.</li> </ul>   |
| COOLANT TEMP [°C] or [°F]    | <ul style="list-style-type: none"> <li>The engine coolant temperature at the moment a malfunction is detected is displayed.</li> </ul>  |
| L-FUEL TRM-B1 [%]            | <ul style="list-style-type: none"> <li>"Long-term fuel trim" at the moment a malfunction is detected is displayed.</li> </ul>   |
| L-FUEL TRM-B2 [%]            | <ul style="list-style-type: none"> <li>The long-term fuel trim indicates much more gradual feedback compensation to the base fuel schedule than short-term fuel trim.</li> </ul>  |
| S-FUEL TRM-B1 [%]            | <ul style="list-style-type: none"> <li>"Short-term fuel trim" at the moment a malfunction is detected is displayed.</li> </ul>  |
| S-FUEL TRM-B2 [%]            | <ul style="list-style-type: none"> <li>The short-term fuel trim indicates dynamic or instantaneous feedback compensation to the base fuel schedule.</li> </ul>  |
| ENGINE SPEED [rpm]           | <ul style="list-style-type: none"> <li>The engine speed at the moment a malfunction is detected is displayed</li> </ul>   |
| VEHICL SPEED [km/h] or [mph] | <ul style="list-style-type: none"> <li>The vehicle speed at the moment a malfunction is detected is displayed</li> </ul>  |
| ABSOL TH-P/S [%]             | <ul style="list-style-type: none"> <li>The throttle valve opening angle at the moment a malfunction is detected is displayed</li> </ul>   |
| B/FUEL SCHDL [msec]          | <ul style="list-style-type: none"> <li>The base fuel schedule at the moment a malfunction is detected is displayed</li> </ul>   |
| INT/A TEMP SE [°C] or [°F]   | <ul style="list-style-type: none"> <li>The intake air temperature at the moment a malfunction is detected is displayed</li> </ul>   |
| FUEL SYS-B1                  | <ul style="list-style-type: none"> <li>"Fuel injection system status" at the moment a malfunction is detected is displayed.</li> <li>One of the following mode is displayed.<br/>Mode2: Open loop due to detected system malfunction<br/>Mode3: Open loop due to driving conditions (power enrichment, deceleration enrichment)<br/>Mode4: Closed loop - using oxygen sensor(s) as feedback for fuel control<br/>Mode5: Open loop - has not yet satisfied condition to go to closed loop</li> </ul> |
| FUEL SYS-B2                  |   |
| INT MANI PRES [kPa]          |   |
| COMBUST CONDITION            | <ul style="list-style-type: none"> <li>These items are displayed but are not applicable to this model.</li> </ul>   |

# DIAGNOSIS SYSTEM (ECM)

[VQ37VHR FOR MEXICO]

< SYSTEM DESCRIPTION >

\*: The items are the same as those of 1st trip freeze frame data.

## DATA MONITOR MODE

Monitored Item

×: Applicable

| Monitored item  | Unit        | Description   | Remarks   |
|-----------------|-------------|---|---|
| ENG SPEED       | rpm         | <ul style="list-style-type: none"> <li>Indicates the engine speed computed from the signal of the crankshaft position sensor (POS) and camshaft position sensor (PHASE).</li> </ul>   | <ul style="list-style-type: none"> <li>Accuracy becomes poor if engine speed drops below the idle rpm.</li> <li>If the signal is interrupted while the engine is running, an abnormal value may be indicated.</li> </ul>  |
| MAS A/F SE-B1   | V           | <ul style="list-style-type: none"> <li>The signal voltage of the mass air flow sensor is displayed.</li> </ul>  | <ul style="list-style-type: none"> <li>When the engine is stopped, a certain value is indicated.</li> <li>When engine is running, specification range is indicated in "SPEC".</li> </ul>  |
| MAS A/F SE-B2   |             |   |   |
| B/FUEL SCHDL    | msec        | <ul style="list-style-type: none"> <li>"Base fuel schedule" indicates the fuel injection pulse width programmed into ECM, prior to any learned on board correction.</li> </ul>  | <ul style="list-style-type: none"> <li>When engine is running, specification range is indicated in "SPEC".</li> </ul>   |
| A/F ALPHA-B1    | %           | <ul style="list-style-type: none"> <li>The mean value of the air-fuel ratio feedback correction factor per cycle is indicated.</li> </ul>   | <ul style="list-style-type: none"> <li>When the engine is stopped, a certain value is indicated.</li> <li>This data also includes the data for the air-fuel ratio learning control.</li> <li>When engine is running, specification range is indicated in "SPEC".</li> </ul> |
| A/F ALPHA-B2    |             |   |   |
| COOLAN TEMP/S   | °C or °F    | <ul style="list-style-type: none"> <li>The engine coolant temperature (determined by the signal voltage of the engine coolant temperature sensor) is displayed.</li> </ul>  | <ul style="list-style-type: none"> <li>When the engine coolant temperature sensor is open or short-circuited, ECM enters fail-safe mode. The engine coolant temperature determined by the ECM is displayed.</li> </ul>  |
| A/F SEN1 (B1)   | V           | <ul style="list-style-type: none"> <li>The A/F signal computed from the input signal of the air fuel ratio (A/F) sensor 1 is displayed.</li> </ul>  |   |
| A/F SEN1 (B2)   |             |   |   |
| HO2S2 (B1)      | V           | <ul style="list-style-type: none"> <li>The signal voltage of the heated oxygen sensor 2 is displayed.</li> </ul>  |   |
| HO2S2 (B2)      |             |   |   |
| HO2S2 MNTR (B1) | RICH/LEAN   | <ul style="list-style-type: none"> <li>Display of heated oxygen sensor 2 signal:<br/>RICH: means the amount of oxygen after three way catalyst is relatively small.<br/>LEAN: means the amount of oxygen after three way catalyst is relatively large.</li> </ul> | <ul style="list-style-type: none"> <li>When the engine is stopped, a certain value is indicated.</li> </ul>   |
| HO2S2 MNTR (B2) |             |   |   |
| VHCL SPEED SE   | km/h or mph | <ul style="list-style-type: none"> <li>The vehicle speed computed from the vehicle speed signal sent from combination meter is displayed.</li> </ul>  |   |
| BATTERY VOLT    | V           | <ul style="list-style-type: none"> <li>The power supply voltage of ECM is displayed.</li> </ul>   |   |
| ACCEL SEN 1     | V           | <ul style="list-style-type: none"> <li>The accelerator pedal position sensor signal voltage is displayed.</li> </ul>  | <ul style="list-style-type: none"> <li>ACCEL SEN 2 signal is converted by ECM internally. Thus, they differs from ECM terminal voltage signal.</li> </ul>   |
| ACCEL SEN 2     |             |   |   |
| TP SEN 1-B1     | V           | <ul style="list-style-type: none"> <li>The throttle position sensor signal voltage is displayed.</li> </ul>   | <ul style="list-style-type: none"> <li>TP SEN 2-B1 signal is converted by ECM internally. Thus, they differs from ECM terminal voltage signal.</li> </ul>   |
| TP SEN 2-B1     |             |   |   |
| FUEL T/TMP SE   | °C or °F    | <ul style="list-style-type: none"> <li>The fuel temperature (determined by the signal voltage of the fuel tank temperature sensor) is displayed.</li> </ul>   |   |
| INT/A TEMP SE   | °C or °F    | <ul style="list-style-type: none"> <li>The intake air temperature (determined by the signal voltage of the intake air temperature sensor) is indicated.</li> </ul>  |   |
| EVAP SYS PRES   | V           | <ul style="list-style-type: none"> <li>The signal voltage of EVAP control system pressure sensor is displayed.</li> </ul>   |   |

A

EC

C

D

E

F

G

H

I

J

K

L

M

N

O

P

# DIAGNOSIS SYSTEM (ECM)

< SYSTEM DESCRIPTION >

[VQ37VHR FOR MEXICO]

| Monitored item | Unit   | Description   | Remarks   |
|----------------|--------|---|---|
| FUEL LEVEL SE  | V      | <ul style="list-style-type: none"> <li>The signal voltage of the fuel level sensor is displayed.</li> </ul>   |   |
| START SIGNAL   | ON/OFF | <ul style="list-style-type: none"> <li>Indicates start signal status [ON/OFF] computed by the ECM according to the signals of engine speed and battery voltage.</li> </ul>  | <ul style="list-style-type: none"> <li>After starting the engine, [OFF] is displayed regardless of the starter signal.</li> </ul>                         |
| CLSD THL POS   | ON/OFF | <ul style="list-style-type: none"> <li>Indicates idle position [ON/OFF] computed by ECM according to the accelerator pedal position sensor signal.</li> </ul>   |   |
| AIR COND SIG   | ON/OFF | <ul style="list-style-type: none"> <li>Indicates [ON/OFF] condition of the air conditioner switch as determined by the air conditioner signal.</li> </ul>   |   |
| P/N POSI SW    | ON/OFF | <ul style="list-style-type: none"> <li>Indicates [ON/OFF] condition from the park/neutral position (PNP) signal.</li> </ul>   |   |
| PW/ST SIGNAL   | ON/OFF | <ul style="list-style-type: none"> <li>[ON/OFF] condition of the power steering system (determined by the signal voltage of the power steering pressure sensor signal) is indicated.</li> </ul>   |   |
| LOAD SIGNAL    | ON/OFF | <ul style="list-style-type: none"> <li>Indicates [ON/OFF] condition from the electrical load signal.</li> <li>ON: Rear window defogger switch is ON and/or lighting switch is in 2nd position.</li> <li>OFF: Both rear window defogger switch and lighting switch are OFF.</li> </ul> |   |
| IGNITION SW    | ON/OFF | <ul style="list-style-type: none"> <li>Indicates [ON/OFF] condition from ignition switch signal.</li> </ul>   |   |
| HEATER FAN SW  | ON/OFF | <ul style="list-style-type: none"> <li>Indicates [ON/OFF] condition from the heater fan switch signal.</li> </ul>   |   |
| BRAKE SW       | ON/OFF | <ul style="list-style-type: none"> <li>Indicates [ON/OFF] condition from the stop lamp switch signal.</li> </ul>  |   |
| INJ PULSE-B1   | msec   | <ul style="list-style-type: none"> <li>Indicates the actual fuel injection pulse width compensated by ECM according to the input signals.</li> </ul>  | <ul style="list-style-type: none"> <li>When the engine is stopped, a certain computed value is indicated.</li> </ul>                                      |
| INJ PULSE-B2   |        |   |   |
| IGN TIMING     | BTDC   | <ul style="list-style-type: none"> <li>Indicates the ignition timing computed by ECM according to the input signals.</li> </ul>   | <ul style="list-style-type: none"> <li>When the engine is stopped, a certain value is indicated.</li> </ul>   |
| CAL/LD VALUE   | %      | <ul style="list-style-type: none"> <li>"Calculated load value" indicates the value of the current air flow divided by peak air flow.</li> </ul>   |   |
| MASS AIRFLOW   | g/s    | <ul style="list-style-type: none"> <li>Indicates the mass air flow computed by ECM according to the signal voltage of the mass air flow sensor.</li> </ul>  |   |
| PURG VOL C/V   | %      | <ul style="list-style-type: none"> <li>Indicates the EVAP canister purge volume control solenoid valve control value computed by the ECM according to the input signals.</li> <li>The opening becomes larger as the value increases.</li> </ul>                                       |   |
| INT/V TIM (B1) | °CA    | <ul style="list-style-type: none"> <li>Indicates [°CA] of intake camshaft advance angle.</li> </ul>   |   |
| INT/V TIM (B2) |        |   |   |
| INT/V SOL (B1) | %      | <ul style="list-style-type: none"> <li>The control value of the intake valve timing control solenoid valve (determined by ECM according to the input signals) is indicated.</li> <li>The advance angle becomes larger as the value increases.</li> </ul>                              |   |
| INT/V SOL (B2) |        |   |   |
| TP SEN 1-B2    | V      | <ul style="list-style-type: none"> <li>The throttle position sensor signal voltage is displayed.</li> </ul>   | <ul style="list-style-type: none"> <li>TP SEN 2-B2 signal is converted by ECM internally. Thus, they differs from ECM terminal voltage signal.</li> </ul> |
| TP SEN 2-B2    |        |   |   |
| AIR COND RLY   | ON/OFF | <ul style="list-style-type: none"> <li>The air conditioner relay control condition (determined by ECM according to the input signals) is indicated.</li> </ul>  |   |

# DIAGNOSIS SYSTEM (ECM)

[VQ37VHR FOR MEXICO]

< SYSTEM DESCRIPTION >

| Monitored item  | Unit        | Description   | Remarks |
|-----------------|-------------|---|---------|
| FUEL PUMP RLY   | ON/OFF      | <ul style="list-style-type: none"> <li>Indicates the fuel pump relay control condition determined by ECM according to the input signals.</li> </ul>   | A       |
| VENT CONT/V     | ON/OFF      | <ul style="list-style-type: none"> <li>The control condition of the EVAP canister vent control valve (determined by ECM according to the input signals) is indicated.<br/>ON: Closed<br/>OFF: Open</li> </ul>                                   | EC      |
| THRTL RELAY     | ON/OFF      | <ul style="list-style-type: none"> <li>Indicates the throttle control motor relay control condition determined by the ECM according to the input signals.</li> </ul>  | C       |
| HO2S2 HTR (B1)  | ON/OFF      | <ul style="list-style-type: none"> <li>Indicates [ON/OFF] condition of heated oxygen sensor 2 heater determined by ECM according to the input signals.</li> </ul>   | D       |
| HO2S2 HTR (B2)  |             |   | E       |
| I/P PULLY SPD   | rpm         | <ul style="list-style-type: none"> <li>Indicates the engine speed computed from the input speed sensor signal.</li> </ul>   | F       |
| VEHICLE SPEED   | km/h or mph | <ul style="list-style-type: none"> <li>The vehicle speed computed from the vehicle speed signal sent from TCM is displayed.</li> </ul>  | G       |
| IDL A/V LEARN   | YET/CMPLT   | <ul style="list-style-type: none"> <li>Displays the condition of Idle Air Volume Learning<br/>YET: Idle air volume learning has not been performed yet.<br/>CMPLT: Idle air volume learning has already been performed successfully.</li> </ul> | H       |
| SNOW MODE SW    | ON/OFF      | <ul style="list-style-type: none"> <li>Indicates [ON/OFF] condition from snow mode switch signal.</li> </ul>  | I       |
| ENG OIL TEMP    | °C or °F    | <ul style="list-style-type: none"> <li>The engine oil temperature (determined by the signal voltage of the engine oil temperature sensor) is displayed.</li> </ul>  | J       |
| TRVL AFTER MIL  | km or mile  | <ul style="list-style-type: none"> <li>Distance traveled while MIL is activated.</li> </ul>   | K       |
| A/F S1 HTR (B1) | %           | <ul style="list-style-type: none"> <li>Air fuel ratio (A/F) sensor 1 heater control value computed by ECM according to the input signals.</li> <li>The current flow to the heater becomes larger as the value increases.</li> </ul>             | L       |
| A/F S1 HTR (B2) |             |   | M       |
| AC PRESS SEN    | V           | <ul style="list-style-type: none"> <li>The signal voltage from the refrigerant pressure sensor is displayed.</li> </ul>   | N       |
| VHCL SPEED SE   | km/h or mph | <ul style="list-style-type: none"> <li>The vehicle speed computed from the vehicle speed signal sent from combination meter is displayed.</li> </ul>  | O       |
| SET VHCL SPD    | km/h or mph | <ul style="list-style-type: none"> <li>The preset vehicle speed is displayed.</li> </ul>  | P       |
| MAIN SW         | ON/OFF      | <ul style="list-style-type: none"> <li>Indicates [ON/OFF] condition from MAIN switch signal.</li> </ul>   |         |
| CANCEL SW       | ON/OFF      | <ul style="list-style-type: none"> <li>Indicates [ON/OFF] condition from CANCEL switch signal.</li> </ul>   |         |
| RESUME/ACC SW   | ON/OFF      | <ul style="list-style-type: none"> <li>Indicates [ON/OFF] condition from RESUME/ACCELERATE switch signal.</li> </ul>  |         |
| SET SW          | ON/OFF      | <ul style="list-style-type: none"> <li>Indicates [ON/OFF] condition from SET/COAST switch signal.</li> </ul>  |         |
| BRAKE SW1       | ON/OFF      | <ul style="list-style-type: none"> <li>Indicates [ON/OFF] condition from ASCD brake switch signal.</li> </ul>   |         |
| BRAKE SW2       | ON/OFF      | <ul style="list-style-type: none"> <li>Indicates [ON/OFF] condition of stop lamp switch signal.</li> </ul>  |         |
| DIST SW         | ON/OFF      | <ul style="list-style-type: none"> <li>Indicates [ON/OFF] condition from DISTANCE switch signal.</li> </ul>   |         |

# DIAGNOSIS SYSTEM (ECM)

< SYSTEM DESCRIPTION >

[VQ37VHR FOR MEXICO]

| Monitored item       | Unit      | Description  | Remarks |
|----------------------|-----------|--|---------|
| CRUISE LAMP          | ON/OFF    | <ul style="list-style-type: none"> <li>Indicates [ON/OFF] condition of CRUISE lamp determined by the ECM according to the input signals.</li> </ul>  |         |
| BAT CUR SEN          | mV        | <ul style="list-style-type: none"> <li>The signal voltage of battery current sensor is displayed.</li> </ul>   |         |
| MAP SENSOR           | V         | <ul style="list-style-type: none"> <li>The signal voltage from the manifold absolute pressure (MAP) sensor is displayed.</li> </ul>  |         |
| ALT DUTY             | %         | <ul style="list-style-type: none"> <li>Indicates the duty ratio of the power generation command value. The ratio is calculated by ECM based on the battery current sensor signal.</li> </ul>   |         |
| BRAKE BST PRES SE    | mV        | <ul style="list-style-type: none"> <li>Always a certain value is displayed.</li> <li>This item is not efficient for Y51 models.</li> </ul>   |         |
| VVEL POSITION SEN-B1 | V         | <ul style="list-style-type: none"> <li>The VVEL control shaft position sensor signal voltage is displayed.</li> </ul>  |         |
| VVEL POSITION SEN-B2 |           |  |         |
| VVEL TIM-B1          | deg       | <ul style="list-style-type: none"> <li>Indicates [deg] of VVEL control shaft angle.</li> </ul>   |         |
| VVEL TIM-B2          |           |  |         |
| VVEL LEARN           | YET/DONE  | <ul style="list-style-type: none"> <li>Display the condition of VVEL learning<br/>YET: VVEL learning has not been performed yet.<br/>DONE: VVEL learning has already been performed successfully.</li> </ul>   |         |
| VVEL SEN LEARN-B1    | V         | <ul style="list-style-type: none"> <li>Indicates the VVEL learning value.</li> </ul>   |         |
| VVEL SEN LEARN-B2    |           |  |         |
| A/F ADJ-B1           | —         | <ul style="list-style-type: none"> <li>Indicates the correction of factor stored in ECM. The factor is calculated from the difference between the target air-fuel ratio stored in ECM and the air-fuel ratio calculated from A/F sensor 1 signal.</li> </ul>   |         |
| A/F ADJ-B2           |           |  |         |
| FAN DUTY             | %         | <ul style="list-style-type: none"> <li>Indicates a command value for cooling fan. The value is calculated by ECM based on input signals.</li> </ul>  |         |
| ALT DUTY SIG         | ON/OFF    | <ul style="list-style-type: none"> <li>The control condition of the power generation voltage variable control (determined by ECM according to the input signals) is indicated.<br/>ON: Power generation voltage variable control is active.<br/>OFF: Power generation voltage variable control is inactive.</li> </ul> |         |
| BAT TEMP SEN         | V         | <ul style="list-style-type: none"> <li>The signal voltage from the battery temperature sensor is displayed.</li> </ul>   |         |
| EVAP LEAK DIAG       | YET/CMPLT | <ul style="list-style-type: none"> <li>Indicates the condition of EVAP leak diagnosis.<br/>YET: EVAP leak diagnosis has not been performed yet.<br/>CMPLT: EVAP leak diagnosis has been performed successfully.</li> </ul>   |         |
| EVAP DIAG READY      | ON/OFF    | <ul style="list-style-type: none"> <li>Indicates the ready condition of EVAP leak diagnosis.<br/>ON: Diagnosis has been ready condition.<br/>OFF: Diagnosis has not been ready condition.</li> </ul>   |         |

# DIAGNOSIS SYSTEM (ECM)

< SYSTEM DESCRIPTION >

[VQ37VHR FOR MEXICO]

| Monitored item      | Unit         | Description   | Remarks |
|---------------------|--------------|---|---------|
| HO2 S2 DIAG1 (B1)   | INCMP/CM-PLT | <ul style="list-style-type: none"> <li>• These items are displayed but are not applicable to this model.</li> </ul> |         |
| HO2 S2 DIAG1 (B2)   | INCMP/CM-PLT |   |         |
| HO2 S2 DIAG2 (B1)   | INCMP/CM-PLT |   |         |
| HO2 S2 DIAG2 (B2)   | INCMP/CM-PLT |   |         |
| A/F SEN1 DIAG2 (B1) | —            | <b>NOTE:</b><br>The item is indicated, but not used.  |         |
| A/F SEN1 DIAG2 (B2) |              |   |         |
| THR TL STK CNT B1   | —            | <b>NOTE:</b><br>The item is indicated, but not used.  |         |
| THR TL STK CNT B2   |              |   |         |

**NOTE:**

Any monitored item that does not match the vehicle being diagnosed is deleted from the display automatically.

## ACTIVE TEST MODE

Test Item

| TEST ITEM         | CONDITION   | JUDGEMENT  | CHECK ITEM (REMEDY)  |
|-------------------|---|--|--|
| VENT CONTROL/V    | <ul style="list-style-type: none"> <li>• Ignition switch: ON (Engine stopped)</li> <li>• Turn solenoid valve ON and OFF with the CONSULT and listen to operating sound.</li> </ul>                            | Solenoid valve makes an operating sound.               | <ul style="list-style-type: none"> <li>• Harness and connectors</li> <li>• Solenoid valve</li> </ul>   |
| ENG COOLANT TEMP  | <ul style="list-style-type: none"> <li>• Engine: Return to the original trouble condition</li> <li>• Change the engine coolant temperature using CONSULT.</li> </ul>  | If trouble symptom disappears, see CHECK ITEM.         | <ul style="list-style-type: none"> <li>• Harness and connectors</li> <li>• Engine coolant temperature sensor</li> <li>• Fuel injector</li> </ul>   |
| FUEL INJECTION    | <ul style="list-style-type: none"> <li>• Engine: Return to the original trouble condition</li> <li>• Change the amount of fuel injection using CONSULT.</li> </ul>  | If trouble symptom disappears, see CHECK ITEM.         | <ul style="list-style-type: none"> <li>• Harness and connectors</li> <li>• Fuel injector</li> <li>• Air fuel ratio (A/F) sensor 1</li> </ul>   |
| FUEL/T TEMP SEN   | <ul style="list-style-type: none"> <li>• Change the fuel tank temperature using CONSULT.</li> </ul>   |  |  |
| PURG VOL CONT/V   | <ul style="list-style-type: none"> <li>• Engine: After warming up, run engine at 1,500 rpm.</li> <li>• Change the EVAP canister purge volume control solenoid valve opening percent using CONSULT.</li> </ul> | Engine speed changes according to the opening percent. | <ul style="list-style-type: none"> <li>• Harness and connectors</li> <li>• Solenoid valve</li> </ul>   |
| FUEL PUMP RELAY   | <ul style="list-style-type: none"> <li>• Ignition switch: ON (Engine stopped)</li> <li>• Turn the fuel pump relay ON and OFF using CONSULT and listen to operating sound.</li> </ul>                          | Fuel pump relay makes the operating sound.             | <ul style="list-style-type: none"> <li>• Harness and connectors</li> <li>• Fuel pump relay</li> </ul>  |
| IGNITION TIMING   | <ul style="list-style-type: none"> <li>• Engine: Return to the original trouble condition</li> <li>• Timing light: Set</li> <li>• Retard the ignition timing using CONSULT.</li> </ul>                        | If trouble symptom disappears, see CHECK ITEM.         | <ul style="list-style-type: none"> <li>• Perform Idle Air Volume Learning.</li> </ul>  |
| FAN DUTY CONTROL* | <ul style="list-style-type: none"> <li>• Ignition switch: ON</li> <li>• Change duty ratio using CONSULT.</li> </ul>   | Cooling fan speed changes.                             | <ul style="list-style-type: none"> <li>• Harness and connectors</li> <li>• Cooling fan motor</li> <li>• Cooling fan relay</li> <li>• Cooling fan control module</li> <li>• IPDM E/R</li> </ul> |
| ALTERNATOR DUTY   | <ul style="list-style-type: none"> <li>• Engine: Idle</li> <li>• Change duty ratio using CONSULT.</li> </ul>  | Battery voltage changes.                               | <ul style="list-style-type: none"> <li>• Harness and connectors</li> <li>• IPDM E/R</li> <li>• Alternator</li> </ul>   |

# DIAGNOSIS SYSTEM (ECM)

< SYSTEM DESCRIPTION >

[VQ37VHR FOR MEXICO]

| TEST ITEM            | CONDITION   | JUDGEMENT   | CHECK ITEM (REMEDY)   |
|----------------------|---|---|---|
| POWER BALANCE        | <ul style="list-style-type: none"> <li>• Engine: After warming up, idle the engine.</li> <li>• A/C switch OFF</li> <li>• Selector lever: P or N</li> <li>• Cut off each injector signal one at a time using CONSULT.</li> </ul> | Engine runs rough or dies.                            | <ul style="list-style-type: none"> <li>• Harness and connectors</li> <li>• Compression</li> <li>• Fuel injector</li> <li>• Power transistor</li> <li>• Spark plug</li> <li>• Ignition coil</li> </ul> |
| INT V/T ASSIGN ANGLE | <ul style="list-style-type: none"> <li>• Engine: Return to the original non-standard condition</li> <li>• Change intake valve timing using CONSULT.</li> </ul>  | If malfunctioning symptom disappears, see CHECK ITEM. | <ul style="list-style-type: none"> <li>• Harness and connectors</li> <li>• Intake valve timing control solenoid valve</li> </ul>  |

\*: Leaving cooling fan OFF with CONSULT while engine is running may cause the engine to overheat.

## DTC & SRT CONFIRMATION MODE

### SRT STATUS Mode

For items whose SRT codes are set, "CMPLT" is displayed on the CONSULT screen; for items whose SRT codes are not set, "INCMP" is displayed.

### SRT WORK SUPPORT Mode

This mode enables a technician to drive a vehicle to set the SRT while monitoring the SRT status.

### DTC WORK SUPPORT Mode

| Test mode | Test item                 | Corresponding DTC No. | Reference page         |
|-----------|---------------------------|-----------------------|------------------------|
| A/F SEN1  | A/F SEN1 (B1) P1278/P1279 | P0133                 | <a href="#">EC-729</a> |
|           | A/F SEN1 (B1) P1276       | P0130                 | <a href="#">EC-719</a> |
|           | A/F SEN1 (B2) P1288/P1289 | P0153                 | <a href="#">EC-729</a> |
|           | A/F SEN1 (B2) P1286       | P0150                 | <a href="#">EC-719</a> |
| HO2S2     | HO2S2 (B1) P1146          | P0138                 | <a href="#">EC-740</a> |
|           | HO2S2 (B1) P1147          | P0137                 | <a href="#">EC-734</a> |
|           | HO2S2 (B1) P0139          | P0139                 | <a href="#">EC-748</a> |
|           | HO2S2 (B2) P1166          | P0158                 | <a href="#">EC-740</a> |
|           | HO2S2 (B2) P1167          | P0157                 | <a href="#">EC-734</a> |
|           | HO2S2 (B2) P0159          | P0159                 | <a href="#">EC-748</a> |



# ECU DIAGNOSIS INFORMATION

## ECM

### Reference Value

INFOID:000000007729710

### VALUES ON THE DIAGNOSIS TOOL

#### NOTE:

- Specification data are reference values.
- Specification data are output/input values which are detected or supplied by the ECM at the connector.
  - \* Specification data may not be directly related to their components signals/values/operations.
    - i.e. Adjust ignition timing with a timing light before monitoring IGN TIMING, because the monitor may show the specification data in spite of the ignition timing not being adjusted to the specification data. This IGN TIMING monitors the data calculated by the ECM according to the signals input from the camshaft position sensor and other ignition timing related sensors.

#### CONSULT MONITOR ITEM

| Monitor Item    | Condition  |                                       | Values/Status                                      |
|-----------------|--|---------------------------------------|--|
| ENG SPEED       | • Run engine and compare CONSULT value with the tachometer indication.   |                                       | Almost the same speed as the tachometer indication |
| MAS A/F SE-B1   | See <a href="#">EC-674, "Description"</a> .  |                                       |  |
| MAS A/F SE-B2   | See <a href="#">EC-674, "Description"</a> .  |                                       |  |
| B/FUEL SCHDL    | See <a href="#">EC-674, "Description"</a> .  |                                       |  |
| A/F ALPHA-B1    | See <a href="#">EC-674, "Description"</a> .  |                                       |  |
| A/F ALPHA-B2    | See <a href="#">EC-674, "Description"</a> .  |                                       |  |
| COOLAN TEMP/S   | • Ignition switch: ON  |                                       | Indicates engine coolant temperature               |
| A/F SEN1 (B1)   | • Engine: After warming up   | Maintaining engine speed at 2,000 rpm | Fluctuates around 2.2 V                            |
| A/F SEN1 (B2)   | • Engine: After warming up   | Maintaining engine speed at 2,000 rpm | Fluctuates around 2.2 V                            |
| HO2S2 (B1)      | <ul style="list-style-type: none"> <li>• Revving engine from idle up to 3,000 rpm quickly after the following conditions are met.</li> <li>- Engine: After warming up</li> <li>- After keeping engine speed between 3,500 and 4,000 rpm for 1 minute and at idle for 1 minute under no load</li> </ul> |                                       | 0 - 0.3 V ↔ Approx. 0.6 - 1.0 V                    |
| HO2S2 (B2)      | <ul style="list-style-type: none"> <li>• Revving engine from idle up to 3,000 rpm quickly after the following conditions are met.</li> <li>- Engine: After warming up</li> <li>- After keeping engine speed between 3,500 and 4,000 rpm for 1 minute and at idle for 1 minute under no load</li> </ul> |                                       | 0 - 0.3 V ↔ Approx. 0.6 - 1.0 V                    |
| HO2S2 MNTR (B1) | <ul style="list-style-type: none"> <li>• Revving engine from idle up to 3,000 rpm quickly after the following conditions are met.</li> <li>- Engine: After warming up</li> <li>- After keeping engine speed between 3,500 and 4,000 rpm for 1 minute and at idle for 1 minute under no load</li> </ul> |                                       | LEAN ↔ RICH  |
| HO2S2 MNTR (B2) | <ul style="list-style-type: none"> <li>• Revving engine from idle up to 3,000 rpm quickly after the following conditions are met.</li> <li>- Engine: After warming up</li> <li>- After keeping engine speed between 3,500 and 4,000 rpm for 1 minute and at idle for 1 minute under no load</li> </ul> |                                       | LEAN ↔ RICH  |
| VHCL SPEED SE   | • Turn drive wheels and compare CONSULT value with the speedometer indication.   |                                       | Almost the same speed as speedometer indication    |
| BATTERY VOLT    | • Ignition switch: ON (Engine stopped)   |                                       | 11 - 14 V  |
| ACCEL SEN 1     | • Ignition switch: ON (Engine stopped)   | Accelerator pedal: Fully released     | 0.45 - 1.00 V                                      |
|                 |  | Accelerator pedal: Fully depressed    | 4.4 - 4.8 V  |
| ACCEL SEN 2*1   | • Ignition switch: ON (Engine stopped)   | Accelerator pedal: Fully released     | 0.45 - 1.00 V                                      |
|                 |  | Accelerator pedal: Fully depressed    | 4.3 - 4.8 V  |

# ECM

## < ECU DIAGNOSIS INFORMATION >

**[VQ37VHR FOR MEXICO]**

| Monitor Item  | Condition  |  | Values/Status                        |
|---------------|--|--|--------------------------------------|
| TP SEN 1-B1   | <ul style="list-style-type: none"> <li>Ignition switch: ON (Engine stopped)</li> <li>Selector lever: D</li> </ul>  | Accelerator pedal: Fully released                                    | More than 0.36 V                     |
|               |  | Accelerator pedal: Fully depressed                                   | Less than 4.75 V                     |
| TP SEN 2-B1*1 | <ul style="list-style-type: none"> <li>Ignition switch: ON (Engine stopped)</li> <li>Selector lever: D</li> </ul>  | Accelerator pedal: Fully released                                    | More than 0.36 V                     |
|               |  | Accelerator pedal: Fully depressed                                   | Less than 4.75 V                     |
| FUEL T/TMP SE | <ul style="list-style-type: none"> <li>Ignition switch: ON</li> </ul>  |  | Indicates fuel tank temperature      |
| INT/A TEMP SE | <ul style="list-style-type: none"> <li>Ignition switch: ON</li> </ul>  |  | Indicates intake air temperature     |
| EVAP SYS PRES | <ul style="list-style-type: none"> <li>Ignition switch: ON</li> </ul>  |  | Approx. 1.8 - 4.8 V                  |
| FUEL LEVEL SE | <ul style="list-style-type: none"> <li>Ignition switch: ON</li> </ul>  |  | Depending on fuel level of fuel tank |
| START SIGNAL  | <ul style="list-style-type: none"> <li>Ignition switch: ON → START → ON</li> </ul>   |  | OFF → ON → OFF                       |
| CLSD THL POS  | <ul style="list-style-type: none"> <li>Ignition switch: ON (Engine stopped)</li> </ul>   | Accelerator pedal: Fully released                                    | ON                                   |
|               |  | Accelerator pedal: Slightly depressed                                | OFF                                  |
| AIR COND SIG  | <ul style="list-style-type: none"> <li>Engine: After warming up, idle the engine</li> </ul>  | Air conditioner switch: OFF  | OFF                                  |
|               |  | Air conditioner switch: ON (Compressor operates.)                    | ON                                   |
| P/N POSI SW   | <ul style="list-style-type: none"> <li>Ignition switch: ON</li> </ul>  | Selector lever: P or N   | ON                                   |
|               |  | Selector lever: Except above   | OFF                                  |
| PW/ST SIGNAL  | <ul style="list-style-type: none"> <li>Engine: After warming up, idle the engine</li> </ul>  | Steering wheel: Not being turned                                     | OFF                                  |
|               |  | Steering wheel: Being turned   | ON                                   |
| LOAD SIGNAL   | <ul style="list-style-type: none"> <li>Ignition switch: ON</li> </ul>  | Rear window defogger switch: ON and/or Lighting switch: 2nd position | ON                                   |
|               |  | Rear window defogger switch and lighting switch: OFF                 | OFF                                  |
| IGNITION SW   | <ul style="list-style-type: none"> <li>Ignition switch: ON → OFF → ON</li> </ul>   |  | ON → OFF → ON                        |
| HEATER FAN SW | <ul style="list-style-type: none"> <li>Engine: After warming up, idle the engine</li> </ul>  | Heater fan switch: ON  | ON                                   |
|               |  | Heater fan switch: OFF   | OFF                                  |
| BRAKE SW      | <ul style="list-style-type: none"> <li>Ignition switch: ON</li> </ul>  | Brake pedal: Fully released  | OFF                                  |
|               |  | Brake pedal: Slightly depressed                                      | ON                                   |
| INJ PULSE-B1  | <ul style="list-style-type: none"> <li>Engine: After warming up</li> <li>Selector lever: P or N</li> <li>Air conditioner switch: OFF</li> <li>No load</li> </ul> | Idle   | 2.0 - 3.0 msec                       |
|               |  | 2,000 rpm  | 1.9 - 2.9 msec                       |
| INJ PULSE-B2  | <ul style="list-style-type: none"> <li>Engine: After warming up</li> <li>Selector lever: P or N</li> <li>Air conditioner switch: OFF</li> <li>No load</li> </ul> | Idle   | 2.0 - 3.0 msec                       |
|               |  | 2,000 rpm  | 1.9 - 2.9 msec                       |
| IGN TIMING    | <ul style="list-style-type: none"> <li>Engine: After warming up</li> <li>Selector lever: P or N</li> <li>Air conditioner switch: OFF</li> <li>No load</li> </ul> | Idle   | 7° BTDC                              |
|               |  | 2,000 rpm  | 25° - 45° BTDC                       |
| CAL/LD VALUE  | <ul style="list-style-type: none"> <li>Engine: After warming up</li> <li>Selector lever: P or N</li> <li>Air conditioner switch: OFF</li> <li>No load</li> </ul> | Idle   | 5% - 35%                             |
|               |  | 2,500 rpm  | 5% - 35%                             |
| MASS AIRFLOW  | <ul style="list-style-type: none"> <li>Engine: After warming up</li> <li>Selector lever: P or N</li> <li>Air conditioner switch: OFF</li> <li>No load</li> </ul> | Idle   | 2.0 - 6.0 g/s                        |
|               |  | 2,500 rpm  | 7.0 - 20.0 g/s                       |

# ECM

## < ECU DIAGNOSIS INFORMATION >

[VQ37VHR FOR MEXICO]

| Monitor Item   | Condition   | Values/Status                                       |
|----------------|---|---|
| PURG VOL C/V   | <ul style="list-style-type: none"> <li>Engine: After warming up</li> <li>Selector lever: P or N</li> <li>Air conditioner switch: OFF</li> <li>No load</li> </ul> Idle<br>(Accelerator pedal: Not depressed even slightly, after engine starting.)                               | 0%  |
|                | 2,000 rpm   | —   |
| INT/V TIM (B1) | <ul style="list-style-type: none"> <li>Engine: After warming up</li> <li>Selector lever: P or N</li> <li>Air conditioner switch: OFF</li> <li>No load</li> </ul> Idle   | - 5 - 5°C   |
|                | 2,000 rpm   | Approx. 0 - 30°C                                    |
| INT/V TIM (B2) | <ul style="list-style-type: none"> <li>Engine: After warming up</li> <li>Selector lever: P or N</li> <li>Air conditioner switch: OFF</li> <li>No load</li> </ul> Idle   | - 5 - 5°C   |
|                | 2,000 rpm   | Approx. 0 - 30°C                                    |
| INT/V SOL (B1) | <ul style="list-style-type: none"> <li>Engine: After warming up</li> <li>Selector lever: P or N</li> <li>Air conditioner switch: OFF</li> <li>No load</li> </ul> Idle   | 0 - 2%  |
|                | 2,000 rpm   | Approx. 0 - 50%                                     |
| INT/V SOL (B2) | <ul style="list-style-type: none"> <li>Engine: After warming up</li> <li>Selector lever: P or N</li> <li>Air conditioner switch: OFF</li> <li>No load</li> </ul> Idle   | 0 - 2%  |
|                | 2,000 rpm   | Approx. 0 - 50%                                     |
| TP SEN 1-B2    | <ul style="list-style-type: none"> <li>Ignition switch: ON (Engine stopped)</li> <li>Selector lever: D</li> </ul> Accelerator pedal: Fully released   | More than 0.36 V                                    |
|                | Accelerator pedal: Fully depressed  | Less than 4.75 V                                    |
| TP SEN 2-B2*1  | <ul style="list-style-type: none"> <li>Ignition switch: ON (Engine stopped)</li> <li>Selector lever: D</li> </ul> Accelerator pedal: Fully released   | More than 0.36 V                                    |
|                | Accelerator pedal: Fully depressed  | Less than 4.75 V                                    |
| AIR COND RLY   | <ul style="list-style-type: none"> <li>Engine: After warming up, idle the engine</li> </ul> Air conditioner switch: OFF   | OFF   |
|                | Air conditioner switch: ON (Compressor operates)  | ON  |
| FUEL PUMP RLY  | <ul style="list-style-type: none"> <li>For 1 second after turning ignition switch: ON</li> <li>Engine running or cranking</li> </ul>  | ON  |
|                | • Except above  | OFF   |
| VENT CONT/V    | • Ignition switch: ON   | OFF   |
| THRTL RELAY    | • Ignition switch: ON   | ON  |
| HO2S2 HTR (B1) | <ul style="list-style-type: none"> <li>Engine speed: Below 3,600 rpm after the following conditions are met.</li> <li>- Engine: After warming up</li> <li>- Keeping the engine speed between 3,500 and 4,000 rpm for 1 minute and at idle for 1 minute under no load</li> </ul> | ON  |
|                | • Engine speed: Above 3,600 rpm   | OFF   |
| HO2S2 HTR (B2) | <ul style="list-style-type: none"> <li>Engine speed: Below 3,600 rpm after the following conditions are met.</li> <li>- Engine: After warming up</li> <li>- Keeping the engine speed between 3,500 and 4,000 rpm for 1 minute and at idle for 1 minute under no load</li> </ul> | ON  |
|                | • Engine speed: Above 3,600 rpm   | OFF   |
| I/P PULLY SPD  | • Vehicle speed: More than 20 km/h (12 MPH)   | Almost the same speed as the tachometer indication  |
| VEHICLE SPEED  | • Turn drive wheels and compare CONSULT value with the speedometer indication.  | Almost the same speed as the speedometer indication |
| IDL A/V LEARN  | <ul style="list-style-type: none"> <li>Engine: Running</li> </ul> Idle air volume learning has not been performed yet.  | YET   |
|                | Idle air volume learning has already been performed successfully.   | CMPLT   |
| SNOW MODE SW   | • Ignition switch: ON   | Snow mode switch: Pressed                           |
|                | Snow mode switch: Released  | OFF   |

A  
EC  
C  
D  
E  
F  
G  
H  
I  
J  
K  
L  
M  
N  
O  
P

# ECM

< ECU DIAGNOSIS INFORMATION >

[VQ37VHR FOR MEXICO]

| Monitor Item                         | Condition  |   | Values/Status                                       |
|--------------------------------------|--|---|---|
| ENG OIL TEMP                         | • Engine: After warming up   |   | More than 70°C (158°F)                              |
| TRVL AFTER MIL                       | • Ignition switch: ON  | Vehicle has traveled after MIL has illuminated.           | 0 - 65,535 km<br>(0 - 40,723 miles)                 |
| A/F S1 HTR (B1)                      | • Engine: After warming up, idle the engine<br>(More than 140 seconds after starting engine)                                 |   | 4 - 100%  |
| A/F S1 HTR (B2)                      | • Engine: After warming up, idle the engine<br>(More than 140 seconds after starting engine)                                 |   | 4 - 100%  |
| AC PRESS SEN                         | • Engine: Idle<br>• Both A/C switch and blower fan switch: ON (Compressor operates)  |   | 1.0 - 4.0 V   |
| VHCL SPEED SE                        | • Turn drive wheels and compare CONSULT value with the speedometer indication.   |   | Almost the same speed as the speedometer indication |
| SET VHCL SPD                         | • Engine: Running  | ASCD: Operating   | The preset vehicle speed is displayed               |
| MAIN SW                              | • Ignition switch: ON  | MAIN switch: Pressed                                      | ON  |
|                                      |  | MAIN switch: Released                                     | OFF   |
| CANCEL SW                            | • Ignition switch: ON  | CANCEL switch: Pressed                                    | ON  |
|                                      |  | CANCEL switch: Released                                   | OFF   |
| RESUME/ACC SW                        | • Ignition switch: ON  | RESUME/ACCELERATE switch: Pressed                         | ON  |
|                                      |  | RESUME/ACCELERATE switch: Released                        | OFF   |
| SET SW                               | • Ignition switch: ON  | SET/COAST switch: Pressed                                 | ON  |
|                                      |  | SET/COAST switch: Released                                | OFF   |
| BRAKE SW1<br>(ICC/ASCD brake switch) | • Ignition switch: ON  | Brake pedal: Fully released                               | ON  |
|                                      |  | Brake pedal: Slightly depressed                           | OFF   |
| BRAKE SW2<br>(Stop lamp switch)      | • Ignition switch: ON  | Brake pedal: Fully released                               | OFF   |
|                                      |  | Brake pedal: Slightly depressed                           | ON  |
| DIST SW                              | • Ignition switch: ON  | DISTANCE switch: Pressed                                  | ON  |
|                                      |  | DISTANCE switch: Released                                 | OFF   |
| CRUISE LAMP                          | • Ignition switch: ON  | MAIN switch: Pressed at the 1st time →<br>at the 2nd time | ON → OFF  |
| BAT CUR SEN                          | • Engine speed: Idle<br>• Battery: Fully charged*2<br>• Selector lever: P or N<br>• Air conditioner switch: OFF<br>• No load |   | Approx. 2,600 - 3,500 mV                            |
| MAP SENSOR                           | • Engine: After warming up<br>• Selector lever: P or N<br>• A/C switch: OFF<br>• No load                                     | Idle  | Approx. 1.0 V                                       |
|                                      |  | 2,000 rpm   | Approx. 1.35 V                                      |
| ALT DUTY                             | • Engine: Idle   |   | 0 - 80%   |
| BRAKE BST PRES SE                    | • This item is displayed but is not applicable to this model.  |   |   |
| VVEL POSITION<br>SEN-B1              | • Engine: After warming up<br>• Selector lever: P or N<br>• Air conditioner switch: OFF<br>• No load                         | Idle  | Approx. 0.25 - 1.40 V                               |
|                                      |  | When revving engine up to 2,000 rpm quickly               | Approx. 0.25 - 4.75 V                               |
| VVEL POSITION<br>SEN-B2              | • Engine: After warming up<br>• Selector lever: P or N<br>• Air conditioner switch: OFF<br>• No load                         | Idle  | Approx. 0.25 - 1.40 V                               |
|                                      |  | When revving engine up to 2,000 rpm quickly               | Approx. 0.25 - 4.75 V                               |

# ECM

## < ECU DIAGNOSIS INFORMATION >

[VQ37VHR FOR MEXICO]

| Monitor Item        | Condition  |  | Values/Status                                       |
|---------------------|--|--|---|
| VVEL TIM-B1         | <ul style="list-style-type: none"> <li>Engine: After warming up</li> <li>Selector lever: P or N</li> <li>Air conditioner switch: OFF</li> <li>No load</li> </ul> | Idle   | Approx. 0 - 20 deg                                  |
|                     |  | When revving engine up to 2,000 rpm quickly            | Approx. 0 - 90 deg                                  |
| VVEL TIM-B2         | <ul style="list-style-type: none"> <li>Engine: After warming up</li> <li>Selector lever: P or N</li> <li>Air conditioner switch: OFF</li> <li>No load</li> </ul> | Idle   | Approx. 0 - 20 deg                                  |
|                     |  | When revving engine up to 2,000 rpm quickly            | Approx. 0 - 90 deg                                  |
| VVEL LEARN          | <ul style="list-style-type: none"> <li>Ignition switch: OFF → ON (After warming up)</li> </ul>   | VVEL learning has not been performed yet.              | YET   |
|                     |  | VVEL learning has already been performed successfully. | DONE  |
| VVEL SEN LEARN-B1   | <ul style="list-style-type: none"> <li>VVEL learning has already been performed successfully</li> </ul>  |  | Approx. 0.30 - 0.80 V                               |
| VVEL SEN LEARN-B2   | <ul style="list-style-type: none"> <li>VVEL learning has already been performed successfully</li> </ul>  |  | Approx. 0.30 - 0.80 V                               |
| A/F ADJ-B1          | <ul style="list-style-type: none"> <li>Engine: Running</li> </ul>  |  | -0.330 - 0.330                                      |
| A/F ADJ-B2          | <ul style="list-style-type: none"> <li>Engine: Running</li> </ul>  |  | -0.330 - 0.330                                      |
| FAN DUTY            | <ul style="list-style-type: none"> <li>Engine: Running</li> </ul>  |  | 0 - 100%  |
| ALT DUTY SIG        | <ul style="list-style-type: none"> <li>Power generation voltage variable control: Operating</li> </ul>   |  | ON  |
|                     | <ul style="list-style-type: none"> <li>Power generation voltage variable control: Not operating</li> </ul>   |  | OFF   |
| BAT TEMP SEN        | <ul style="list-style-type: none"> <li>Engine: After warming up</li> <li>Selector lever: P or N</li> <li>A/C switch: OFF</li> <li>No load</li> </ul>             | Idle   | Indicates the temperature around the battery.       |
| EVAP LEAK DIAG      | <ul style="list-style-type: none"> <li>Ignition switch: ON</li> </ul>  |  | Depending on condition of EVAP leak diagnosis       |
| EVAP DIAG READY     | <ul style="list-style-type: none"> <li>Ignition switch: ON (READY)</li> </ul>  |  | Depending on ready condition of EVAP leak diagnosis |
| HO2 S2 DIAG1 (B1)   | <ul style="list-style-type: none"> <li>This item is displayed but is not applicable to this model.</li> </ul>  |  |   |
| HO2 S2 DIAG1 (B2)   | <ul style="list-style-type: none"> <li>This item is displayed but is not applicable to this model.</li> </ul>  |  |   |
| HO2 S2 DIAG2 (B1)   | <ul style="list-style-type: none"> <li>This item is displayed but is not applicable to this model.</li> </ul>  |  |   |
| HO2 S2 DIAG2 (B2)   | <ul style="list-style-type: none"> <li>This item is displayed but is not applicable to this model.</li> </ul>  |  |   |
| A/F SEN1 DIAG2 (B1) | <ul style="list-style-type: none"> <li>This item is displayed but is not applicable to this model.</li> </ul>  |  |   |
| A/F SEN1 DIAG2 (B2) | <ul style="list-style-type: none"> <li>This item is displayed but is not applicable to this model.</li> </ul>  |  |   |
| THRTL STK CNT B1    | <ul style="list-style-type: none"> <li>This item is displayed but is not applicable to this model.</li> </ul>  |  |   |
| THRTL STK CNT B2    | <ul style="list-style-type: none"> <li>This item is displayed but is not applicable to this model.</li> </ul>  |  |   |

\*1: Accelerator pedal position sensor 2 signal and throttle position sensor 2 signal are converted by ECM internally. Thus, they differ from ECM terminals voltage signal.

\*2: Before measuring the terminal voltage, confirm that the battery is fully charged. Refer to [PG-135, "How to Handle Battery"](#).

TERMINAL LAYOUT

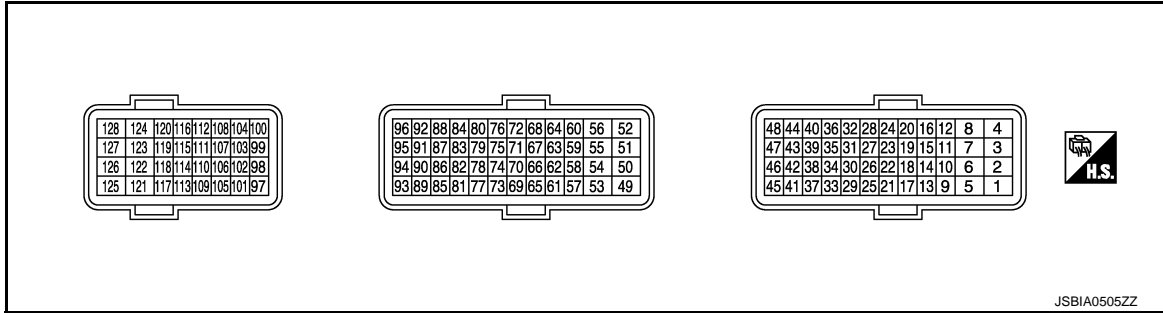

PHYSICAL VALUES

NOTE:

- ECM is located behind the instrument assist lower panel. For this inspection, remove passenger side instrument lower panel.
- Specification data are reference values and are measured between each terminal and ground.
- Pulse signal is measured by CONSULT.

| Terminal No.<br>(Wire color) |            | Description                                     |                  | Condition   | Value<br>(Approx.)              |
|------------------------------|------------|---|------------------|---|---------------------------------|
| +                            | —          | Signal name                                     | Input/<br>Output |   |                                 |
| 1<br>(W)                     | 128<br>(B) | A/F sensor 1 heater<br>(bank 1)                 | Output           | [Engine is running]<br>• Warm-up condition<br>• Idle speed<br>(More than 140 seconds after starting engine)                   | 2.9 - 8.8 V★<br><br>JMBIA0030GB |
| 2<br>(G)                     | 128<br>(B) | Throttle control motor<br>(Open) (bank 1)       | Output           | [Ignition switch: ON]<br>• Engine stopped<br>• Selector lever: D<br>• Accelerator pedal: Fully depressed                      | 0 - 14 V★<br><br>JMBIA0031GB    |
|                              |            |   |                  | [Ignition switch: ON]<br>• Engine stopped<br>• Selector lever: D<br>• Accelerator pedal: Fully released                       | 0 - 14 V★<br><br>JMBIA0032GB    |
| 3<br>(R)                     | 128<br>(B) | Throttle control motor<br>power supply (bank 1) | Input            | [Ignition switch: ON]   | BATTERY VOLTAGE<br>(11 - 14 V)  |
| 4<br>(BR)                    | 128<br>(B) | Throttle control motor<br>(Close) (bank 1)      | Output           | [Ignition switch: ON]<br>• Engine stopped<br>• Selector lever: D<br>• Accelerator pedal: In the middle of releasing operation | 0 - 14 V★<br><br>JMBIA0033GB    |

# ECM

< ECU DIAGNOSIS INFORMATION >

[VQ37VHR FOR MEXICO]

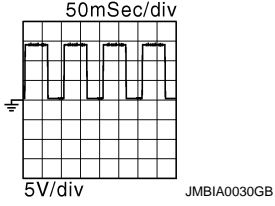
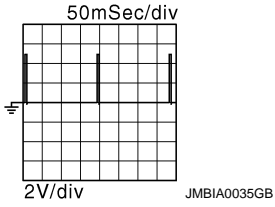
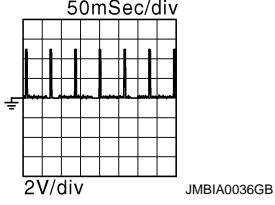
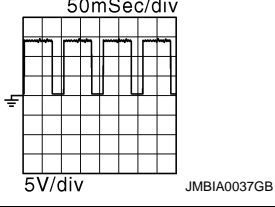
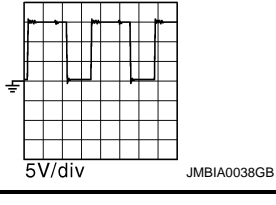
| Terminal No.<br>(Wire color) |            | Description   |                  | Condition   | Value<br>(Approx.)   |
|------------------------------|------------|---|------------------|---|--|
| +                            | --         | Signal name   | Input/<br>Output |   |  |
| 5<br>(L)                     | 128<br>(B) | A/F sensor 1 heater<br>(bank 2)                     | Output           | [Engine is running]<br>• Warm-up condition<br>• Idle speed<br>(More than 140 seconds after starting engine)   | 2.9 - 8.8 V★<br>  |
| 8<br>(B)                     | —          | ECM ground  | —                | —   | —  |
| 11<br>(GR)                   | 128<br>(B) | Ignition signal No. 4                               | Output           | [Engine is running]<br>• Warm-up condition<br>• Idle speed<br><b>NOTE:</b><br>The pulse cycle changes depending on rpm at idle  | 0 - 0.2 V★<br>    |
| 12<br>(L)                    |            | Ignition signal No. 3                               |                  |   |  |
| 15<br>(LG)                   |            | Ignition signal No. 5                               |                  |   |  |
| 16<br>(G)                    |            | Ignition signal No. 2                               |                  |   |  |
| 19<br>(V)                    |            | Ignition signal No. 6                               |                  |   |  |
| 20<br>(Y)                    |            | Ignition signal No. 1                               |                  | [Engine is running]<br>• Warm-up condition<br>• Engine speed: 2,000 rpm   | 0.1 - 0.4 V★<br> |
| 17<br>(P)                    | 128<br>(B) | Heated oxygen sensor 2 heater (bank 1)              | Output           | [Engine is running]<br>• Engine speed: Below 3,600 rpm after the following conditions are met<br>- Engine: after warming up<br>- Keeping the engine speed between 3,500 and 4,000 rpm for 1 minute and at idle for 1 minute under no load | 10 V★<br>       |
|                              |            |   |                  | [Ignition switch: ON]<br>• Engine stopped<br>[Engine is running]<br>• Engine speed: Above 3,600 rpm   | BATTERY VOLTAGE<br>(11 - 14 V)   |
| 18<br>(Y)                    | 128<br>(B) | Intake valve timing control solenoid valve (bank 1) | Output           | [Engine is running]<br>• Warm-up condition<br>• Idle speed  | BATTERY VOLTAGE<br>(11 - 14 V)   |
|                              |            |   |                  | [Engine is running]<br>• Warm-up condition<br>• Engine speed: 2,000rpm  | 7 - 12 V★<br>   |

A

EC

C

D

E

F

G

H

I

J

K

L

M

N

O

P

# ECM

< ECU DIAGNOSIS INFORMATION >

[VQ37VHR FOR MEXICO]

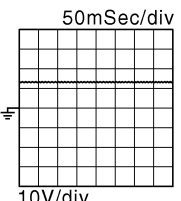
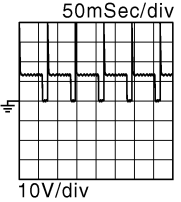
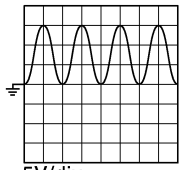
| Terminal No.<br>(Wire color) |            | Description  |                  | Condition  | Value<br>(Approx.)   |
|------------------------------|------------|--|------------------|--|--|
| +                            | -          | Signal name  | Input/<br>Output |  |  |
| 21<br>(GR)                   | 128<br>(B) | EVAP canister purge volume control solenoid valve            | Output           | [Engine is running]<br>• Idle speed<br>• Accelerator pedal: Not depressed even slightly, after engine starting | BATTERY VOLTAGE<br>(11 - 14 V)★<br> |
|                              |            |  |                  | [Engine is running]<br>• Engine speed: About 2,000 rpm (More than 100 seconds after starting engine)           | BATTERY VOLTAGE<br>(11 - 14 V)★<br> |
| 22<br>(B)                    | 128<br>(B) | Fuel pump relay  | Output           | [Ignition switch: ON]<br>• For 1 second after turning ignition switch ON                                       | 0 - 1.5 V  |
|                              |            |  |                  | [Engine is running]<br>• More than 1 second after turning ignition switch ON                                   | BATTERY VOLTAGE<br>(11 - 14 V)   |
| 24<br>(V)                    | 128<br>(B) | ECM relay (Self shut-off)                                    | Output           | [Engine is running]<br>[Ignition switch: OFF]<br>• A few seconds after turning ignition switch OFF             | 0 - 1.5 V  |
|                              |            |  |                  | [Ignition switch: OFF]<br>• More than a few seconds after turning ignition switch OFF                          | BATTERY VOLTAGE<br>(11 - 14 V)   |
| 25<br>(O)                    | 128<br>(B) | Throttle control motor relay                                 | Output           | [Ignition switch: ON → OFF]  | 0 - 1.0 V<br>↓<br>BATTERY VOLTAGE<br>(11 - 14 V)<br>↓<br>0 V   |
|                              |            |  |                  | [Ignition switch: ON]  | 0 - 1.0 V  |
| 28<br>(R)                    | 128<br>(B) | VVEL actuator motor relay abort signal [VVEL control module] | Output           | [Engine is running]<br>• Warm-up condition<br>• Idle speed   | 0 V  |
| 29<br>(Y)                    | 128<br>(B) | Intake valve timing control solenoid valve (bank 2)          | Output           | [Engine is running]<br>• Warm-up condition<br>• Idle speed   | BATTERY VOLTAGE<br>(11 - 14 V)   |
|                              |            |  |                  | [Engine is running]<br>• Warm-up condition<br>• Engine speed: 2,000rpm   | 7 - 12 V★<br>                     |



# ECM

< ECU DIAGNOSIS INFORMATION >

[VQ37VHR FOR MEXICO]

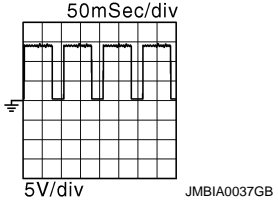
| Terminal No.<br>(Wire color) |             | Description                               |                  | Condition  | Value<br>(Approx.)  |
|------------------------------|-------------|---|------------------|--|---|
| +                            | --          | Signal name                               | Input/<br>Output |  |   |
| 30<br>(O)                    | 40<br>(O/L) | Throttle position sensor<br>1 (bank 1)    | Input            | [Ignition switch: ON]<br>• Engine stopped<br>• Selector lever: D<br>• Accelerator pedal: Fully released  | More than 0.36 V  |
|                              |             |   |                  | [Ignition switch: ON]<br>• Engine stopped<br>• Selector lever: D<br>• Accelerator pedal: Fully depressed   | Less than 4.75 V  |
| 31<br>(O/L)                  | 48<br>(O)   | Throttle position sensor<br>1 (bank 2)    | Input            | [Ignition switch: ON]<br>• Engine stopped<br>• Selector lever: D<br>• Accelerator pedal: Fully released  | More than 0.36 V  |
|                              |             |   |                  | [Ignition switch: ON]<br>• Engine stopped<br>• Selector lever: D<br>• Accelerator pedal: Fully depressed   | Less than 4.75 V  |
| 33<br>(LG)                   | 128<br>(B)  | Heated oxygen sensor 2<br>heater (bank 2) | Output           | [Engine is running]<br>• Engine speed: Below 3,600 rpm after<br>the following conditions are met<br>- Engine: after warming up<br>- Keeping the engine speed between<br>3,500 and 4,000 rpm for 1 minute and at<br>idle for 1 minute under no load | 10 V★<br> |
|                              |             |   |                  | [Ignition switch: ON]<br>• Engine stopped<br>[Engine is running]<br>• Engine speed: Above 3,600 rpm  | BATTERY VOLTAGE<br>(11 - 14 V)  |
| 34<br>(W/L)                  | 40<br>(O/L) | Throttle position sensor<br>2 (bank 1)    | Input            | [Ignition switch: ON]<br>• Engine stopped<br>• Selector lever: D<br>• Accelerator pedal: Fully released  | Less than 4.75 V  |
|                              |             |   |                  | [Ignition switch: ON]<br>• Engine stopped<br>• Selector lever: D<br>• Accelerator pedal: Fully depressed   | More than 0.36 V  |
| 35<br>(W)                    | 48<br>(O)   | Throttle position sensor<br>2 (bank 2)    | Input            | [Ignition switch: ON]<br>• Engine stopped<br>• Selector lever: D<br>• Accelerator pedal: Fully released  | Less than 4.75 V  |
|                              |             |   |                  | [Ignition switch: ON]<br>• Engine stopped<br>• Selector lever: D<br>• Accelerator pedal: Fully depressed   | More than 0.36 V  |

A  
EC  
C  
D  
E  
F  
G  
H  
I  
J  
K  
L  
M  
N  
O  
P

# ECM

< ECU DIAGNOSIS INFORMATION >

[VQ37VHR FOR MEXICO]

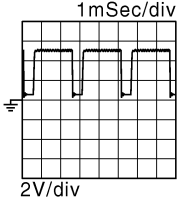
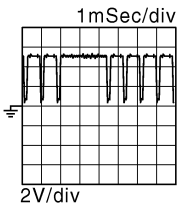
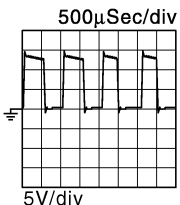
| Terminal No.<br>(Wire color) |             | Description   |                  | Condition  | Value<br>(Approx.)  |
|------------------------------|-------------|---|------------------|--|---|
| +                            | --          | Signal name   | Input/<br>Output |  |   |
| 37<br>(L)                    | 128<br>(B)  | Crankshaft position sensor (POS)                        | Input            | [Engine is running] <ul style="list-style-type: none"> <li>• Warm-up condition</li> <li>• Idle speed</li> </ul> <b>NOTE:</b><br>The pulse cycle changes depending on rpm at idle         | 4.0 - 5.0 V★<br> |
|                              |             |   |                  | [Engine is running] <ul style="list-style-type: none"> <li>• Engine speed: 2,000 rpm</li> </ul>  | 4.0 - 5.0 V★<br> |
| 38<br>(W)                    | 96<br>(O)   | Manifold absolute pressure (MAP) sensor                 | Input            | [Engine is running] <ul style="list-style-type: none"> <li>• Warm-up condition</li> <li>• Idle speed</li> </ul>  | 1.2 V   |
|                              |             |   |                  | [Engine is running] <ul style="list-style-type: none"> <li>• Warm-up condition</li> <li>• Engine speed: 2,000 rpm</li> </ul>   | 1.5 V   |
| 40<br>(O/L)                  | —           | Sensor ground [Throttle position sensor (bank 1)]       | —                | —  | —   |
| 43<br>(W/L)                  | 48<br>(O)   | Sensor power supply [Throttle position sensor (bank 2)] | —                | [Ignition switch: ON]  | 5 V   |
| 44<br>(W)                    | 40<br>(O/L) | Sensor power supply [Throttle position sensor (bank 1)] | —                | [Ignition switch: ON]  | 5 V   |
| 46<br>(R)                    | 128<br>(B)  | Sensor power supply [Crankshaft position sensor (POS)]  | —                | [Ignition switch: ON]  | 5 V   |
| 47<br>(B)                    | —           | Sensor ground [Crankshaft position sensor (POS)]        | —                | —  | —   |
| 48<br>(O)                    | —           | Sensor ground [Throttle position sensor (bank 2)]       | —                | —  | —   |
| 49<br>(LG)                   | 128<br>(B)  | Throttle control motor (Close) (bank 2)                 | Output           | [Ignition switch: ON] <ul style="list-style-type: none"> <li>• Engine stopped</li> <li>• Selector lever: D</li> <li>• Accelerator pedal: In the middle of releasing operation</li> </ul> | 0 - 14 V★<br>  |

# ECM

< ECU DIAGNOSIS INFORMATION >

[VQ37VHR FOR MEXICO]

| Terminal No.<br>(Wire color) |            | Description  |                  | Condition   | Value<br>(Approx.)                                      |
|------------------------------|------------|--|------------------|---|---|
| +                            | --         | Signal name  | Input/<br>Output |   |   |
| 50<br>(V)                    | 128<br>(B) | Throttle control motor<br>(Open) (bank 2)  | Output           | [Ignition switch: ON]<br>• Engine stopped<br>• Selector lever: D<br>• Accelerator pedal: Fully depressed                          | 0 - 14 V★<br><br>500µSec/div<br>5V/div<br>JMBIA0031GB   |
|                              |            |  |                  | [Ignition switch: ON]<br>• Engine stopped<br>• Selector lever: D<br>• Accelerator pedal: Fully released                           | 0 - 14 V★<br><br>500µSec/div<br>5V/div<br>JMBIA0032GB   |
| 52<br>(R)                    | 128<br>(B) | Throttle control motor<br>power supply (bank 2)  | Input            | [Ignition switch: ON]   | BATTERY VOLTAGE<br>(11 - 14 V)                          |
| 53<br>(G)                    | 128<br>(B) | Ignition switch  | Input            | [Ignition switch: OFF]  | 0 V   |
|                              |            |  |                  | [Ignition switch: ON]   | BATTERY VOLTAGE<br>(11 - 14 V)                          |
| 54<br>(L)                    | —          | CAN communication line<br>[VVEL control module]  | Input/<br>output | —   | —   |
| 55<br>(Y)                    | —          | CAN communication line<br>[VVEL control module]  | Input/<br>output | —   | —   |
| 57<br>(L)                    | 128<br>(B) | A/F sensor 1 (bank 1)  | Input            | [Ignition switch: ON]   | 2.2 V   |
| 59<br>(L)                    | 128<br>(B) | Camshaft position sen-<br>sor (PHASE) (bank 1)   | Input            | [Engine is running]<br>• Warm-up condition<br>• Idle speed<br><b>NOTE:</b><br>The pulse cycle changes depending on<br>rpm at idle | 3.0 - 5.0 V★<br><br>20mSec/div<br>2V/div<br>JMBIA0045GB |
|                              |            |  |                  | [Engine is running]<br>• Engine speed: 2,000 rpm  | 3.0 - 5.0 V★<br><br>20mSec/div<br>2V/div<br>JMBIA0046GB |
| 60<br>(G)                    | 128<br>(B) | Sensor power supply<br>[Camshaft position sen-<br>sor (PHASE) (bank 1),<br>Manifold absolute pres-<br>sure (MAP) sensor, Pow-<br>er steering pressure<br>sensor] | —                | [Ignition switch: ON]   | 5 V   |
| 61<br>(B/W)                  | 128<br>(B) | A/F sensor 1 (bank 1)  | Input            | [Engine is running]<br>• Warm-up condition<br>• Engine speed: 2,000 rpm   | 1.8 V<br>Output voltage varies with air fuel<br>ratio.  |

A

EC

C

D

E

F

G

H

I

J

K

L

M

N

O

P

# ECM

< ECU DIAGNOSIS INFORMATION >

[VQ37VHR FOR MEXICO]

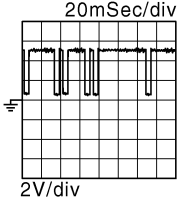
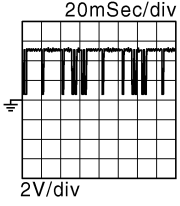
| Terminal No.<br>(Wire color) |            | Description  |                  | Condition   | Value<br>(Approx.)   |
|------------------------------|------------|--|------------------|---|--|
| +                            | -          | Signal name  | Input/<br>Output |   |  |
| 63<br>(BR)                   | 128<br>(B) | Camshaft position sensor (PHASE) (bank 2)  | Input            | [Engine is running]<br>• Warm-up condition<br>• Idle speed<br><b>NOTE:</b><br>The pulse cycle changes depending on rpm at idle  | 3.0 - 5.0 V★<br><br>JMBIA0045GB |
|                              |            |  |                  | [Engine is running]<br>• Engine speed: 2,000 rpm  | 3.0 - 5.0 V★<br><br>JMBIA0046GB |
| 64<br>(W)                    | 128<br>(B) | Sensor power supply<br>[Camshaft position sensor (PHASE) (bank 2), Battery current sensor] | —                | [Ignition switch: ON]   | 5 V  |
| 65<br>(L/O)                  | 128<br>(B) | A/F sensor 1 (bank 2)  | Input            | [Ignition switch: ON]   | 2.2 V  |
| 66<br>(W/L)                  | 128<br>(B) | A/F sensor 1 (bank 2)  | Input            | [Engine is running]<br>• Warm-up condition<br>• Engine speed: 2,000 rpm   | 1.8 V<br>Output voltage varies with air fuel ratio.  |
| 67<br>(Y)                    | 128<br>(B) | Intake air temperature sensor  | Input            | [Engine is running]   | 0 - 4.8 V<br>Output voltage varies with intake air temperature.  |
| 68<br>(V)                    | —          | Sensor ground<br>[Mass air flow sensor (bank 1), Intake air temperature sensor]            | —                | —   | —  |
| 69<br>(GR)                   | 128<br>(B) | Knock sensor (bank 2)  | Input            | [Engine is running]<br>• Idle speed   | 2.5 V*1  |
| 71<br>(SB)                   | 128<br>(B) | Engine coolant temperature sensor  | Input            | [Engine is running]   | 0 - 4.8 V<br>Output voltage varies with engine coolant temperature.  |
| 72<br>(—)                    | —          | Sensor ground<br>(Knock sensor)  | —                | —   | —  |
| 73<br>(W)                    | 128<br>(B) | Knock sensor (bank 1)  | Input            | [Engine is running]<br>• Idle speed   | 2.5 V*1  |
| 76<br>(BR)                   | 128<br>(B) | Heated oxygen sensor 2 (bank 1)  | Input            | [Engine is running]<br>• Revving engine from idle to 3,000 rpm quickly after the following conditions are met<br>- Engine: after warming up<br>- Keeping the engine speed between 3,500 and 4,000 rpm for 1 minute and at idle for 1 minute under no load | 0 - 1.0 V  |

# ECM

< ECU DIAGNOSIS INFORMATION >

[VQ37VHR FOR MEXICO]

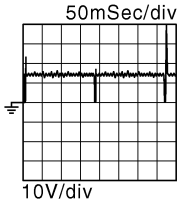
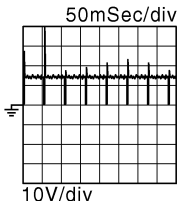
| Terminal No.<br>(Wire color) |                     | Description  |                  | Condition   | Value<br>(Approx.)   |
|------------------------------|---------------------|--|------------------|---|--|
| +                            | --                  | Signal name  | Input/<br>Output |   |  |
| 77<br>(O)                    | 68<br>(V)           | Mass air flow sensor<br>(bank 1)   | Input            | [Engine is running]<br>• Warm-up condition<br>• Idle speed  | 0.7 - 1.2 V  |
|                              |                     |  |                  | [Engine is running]<br>• Warm-up condition<br>• Engine speed: 2,500 rpm   | 1.3 - 1.7 V  |
| 78<br>(G)                    | 84<br>(B/W)         | Engine oil temperature<br>sensor   | Input            | [Engine is running]   | 0 - 4.8 V<br>Output voltage varies with engine<br>oil temperature.   |
| 79<br>(BR)                   | 94<br>(B)           | Mass air flow sensor<br>(bank 2)   | Input            | [Engine is running]<br>• Warm-up condition<br>• Idle speed  | 0.7 - 1.2 V  |
|                              |                     |  |                  | [Engine is running]<br>• Warm-up condition<br>• Engine speed: 2,500 rpm   | 1.3 - 1.7 V  |
| 80<br>(L)                    | 128<br>(B)          | Heated oxygen sensor 2<br>(bank 2)   | Input            | [Engine is running]<br>• Revving engine from idle to 3,000 rpm<br>quickly after the following conditions are<br>met<br>- Engine: after warming up<br>- Keeping the engine speed between<br>3,500 and 4,000 rpm for 1 minute and at<br>idle for 1 minute under no load | 0 - 1.0 V  |
| 81<br>(Y)                    | 128<br>(B)          | Fuel injector No. 3  | Output           | [Engine is running]<br>• Warm-up condition<br>• Idle speed<br><b>NOTE:</b><br>The pulse cycle changes depending on<br>rpm at idle   | BATTERY VOLTAGE<br>(11 - 14 V)★<br> |
| 82<br>(V)                    |                     | Fuel injector No. 6  |                  |   |  |
| 85<br>(BR)                   |                     | Fuel injector No. 2  |                  |   |  |
| 86<br>(R)                    |                     | Fuel injector No. 5  |                  |   |  |
| 89<br>(GR)                   |                     | Fuel injector No. 1  |                  |   |  |
| 90<br>(O)                    | Fuel injector No. 4 |  |                  | [Engine is running]<br>• Warm-up condition<br>• Engine speed: 2,000 rpm   | BATTERY VOLTAGE<br>(11 - 14 V)★<br> |
| 83<br>(GR)                   | 128<br>(B)          | Battery temperature<br>sensor  | Input            | [Engine is running]<br>• Battery: Fully charged*2<br>• Idle speed   | 1.6 V  |
| 84<br>(B/W)                  | —                   | Sensor ground<br>(Heated oxygen sensor<br>2, Engine coolant tem-<br>perature sensor, Engine<br>oil temperature sensor) | —                | —   | —  |
| 87<br>(V)                    | 96<br>(O)           | Power steering pressure<br>sensor  | Output           | [Engine is running]<br>• Steering wheel: Being turned   | 0.5 - 4.5 V  |
|                              |                     |  |                  | [Engine is running]<br>• Steering wheel: Not being turned   | 0.4 - 0.8 V  |

A

EC

C

D

E

F

G

H

I

J

K

L

M

N

O

P

# ECM

< ECU DIAGNOSIS INFORMATION >

[VQ37VHR FOR MEXICO]

| Terminal No.<br>(Wire color) |  | Description   |                  | Condition   | Value<br>(Approx.)             |
|------------------------------|--|---|------------------|---|--------------------------------|
| +                            | —  | Signal name   | Input/<br>Output |   |                                |
| 91<br>(G)                    | 95<br>(W)                                      | Battery current sensor  | Input            | [Engine is running]<br>• Battery: Fully charged* <sup>2</sup><br>• Idle speed     | 2.6 - 3.5 V                    |
| 92<br>(R)                    | —  | Sensor ground<br>[Camshaft position sensor (PHASE) (bank 2)]  | —                | —   | —                              |
| 93<br>(W)                    | 128<br>(B)                                     | Power supply for ECM<br>(Back-up)   | Input            | [Ignition switch: OFF]  | BATTERY VOLTAGE<br>(11 - 14 V) |
| 94<br>(B)                    | —  | Sensor ground<br>[Mass air flow sensor (bank 2)]  | —                | —   | —                              |
| 95<br>(W)                    | —  | Sensor ground<br>(Battery current sensor)   | —                | —   | —                              |
| 96<br>(O)                    | —  | Sensor ground<br>[Camshaft position sensor (PHASE) (bank 1), Manifold absolute pressure (MAP) sensor, Power steering pressure sensor] | —                | —   | —                              |
| 97<br>(R)                    | 100<br>(W)                                     | Accelerator pedal position sensor 1   | Input            | [Ignition switch: ON]<br>• Engine stopped<br>• Accelerator pedal: Fully released  | 0.45 - 1.00 V                  |
|                              |  |   |                  | [Ignition switch: ON]<br>• Engine stopped<br>• Accelerator pedal: Fully depressed | 4.2 - 4.8 V                    |
| 98<br>(Y)                    | 104<br>(BR) <sup>*3</sup><br>(B) <sup>*4</sup> | Accelerator pedal position sensor 2   | Input            | [Ignition switch: ON]<br>• Engine stopped<br>• Accelerator pedal: Fully released  | 0.22 - 0.50 V                  |
|                              |  |   |                  | [Ignition switch: ON]<br>• Engine stopped<br>• Accelerator pedal: Fully depressed | 2.1 - 2.5 V                    |
| 99<br>(G)                    | 100<br>(W)                                     | Sensor power supply<br>(Accelerator pedal position sensor 1)  | —                | [Ignition switch: ON]   | 5 V                            |
| 100<br>(W)                   | —  | Sensor ground<br>(Accelerator pedal position sensor 1)  | —                | —   | —                              |

# ECM

< ECU DIAGNOSIS INFORMATION >

[VQ37VHR FOR MEXICO]

| Terminal No.<br>(Wire color)                   |  | Description   |                  | Condition   | Value<br>(Approx.)   |    |
|--|--|---|------------------|---|--|----|
| +  | --   | Signal name   | Input/<br>Output |   |  |    |
| 101<br>(SB)                                    | 108<br>(Y)                                     | ICC steering switch<br>(models with ICC system)   | Input            | [Ignition switch: ON]<br>• ICC steering switch: OFF   | 4.2 V  | A  |
|  |  |   |                  | [Ignition switch: ON]<br>• MAIN switch: Pressed   | 0 V  | EC |
|  |  |   |                  | [Ignition switch: ON]<br>• DYNAMIC DRIVE ASSISTANCE SYSTEMS switch: Pressed   | 1.0 V  | C  |
|  |  |   |                  | [Ignition switch: ON]<br>• CANCEL switch: Pressed   | 1.9 V  | D  |
|  |  |   |                  | [Ignition switch: ON]<br>• RESUME/ACCELERATE switch: Pressed  | 3.7 V  | E  |
|  |  |   |                  | [Ignition switch: ON]<br>• SET/COAST switch: Pressed  | 3.2 V  | F  |
|  |  |   |                  | [Ignition switch: ON]<br>• DISTANCE switch: Pressed   | 2.6 V  | G  |
| 101<br>(SB)                                    | 108<br>(Y)                                     | ASCD steering switch<br>(models with ASCD system)   | Input            | [Ignition switch: ON]<br>• ASCD steering switch: OFF  | 4 V  | H  |
|  |  |   |                  | [Ignition switch: ON]<br>• MAIN switch: Pressed   | 0 V  | I  |
|  |  |   |                  | [Ignition switch: ON]<br>• CANCEL switch: Pressed   | 1 V  | J  |
|  |  |   |                  | [Ignition switch: ON]<br>• RESUME/ACCELERATE switch: Pressed  | 3 V  | K  |
|  |  |   |                  | [Ignition switch: ON]<br>• SET/COAST switch: Pressed  | 2 V  | L  |
| 102<br>(P)                                     | 112<br>(V)                                     | EVAP control system pressure sensor   | Input            | [Ignition switch: ON]   | 1.8 - 4.8 V  | M  |
| 103<br>(L)                                     | 104<br>(BR) <sup>*3</sup><br>(B) <sup>*4</sup> | Sensor power supply<br>(Accelerator pedal position sensor 2)                              | —                | [Ignition switch: ON]   | 5 V  | N  |
| 104<br>(BR) <sup>*3</sup><br>(B) <sup>*4</sup> | —  | Sensor ground<br>(Accelerator pedal position sensor 2)                                    | —                | —   | —  | O  |
| 105<br>(LG)                                    | 112<br>(V)                                     | Refrigerant pressure sensor   | Input            | [Engine is running]<br>• Warm-up condition<br>• Both A/C switch and blower fan motor switch: ON (Compressor operates) | 1.0 - 4.0 V  | P  |
| 106<br>(P)                                     | 128<br>(B)                                     | Fuel tank temperature sensor  | Input            | [Engine is running]   | 0 - 4.8 V<br>Output voltage varies with fuel tank temperature. |    |
| 107<br>(BG)                                    | 112<br>(V)                                     | Sensor power supply<br>(EVAP control system pressure sensor, Refrigerant pressure sensor) | —                | [Ignition switch: ON]   | 5 V  |    |
| 108<br>(Y)                                     | —  | Sensor ground<br>(ASCD/ICC steering switch)   | —                | —   | —  |    |

# ECM

< ECU DIAGNOSIS INFORMATION >

[VQ37VHR FOR MEXICO]

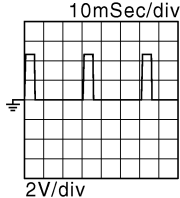
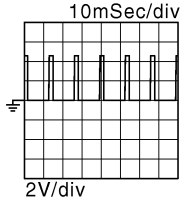
| Terminal No.<br>(Wire color) |            | Description  |                  | Condition  | Value<br>(Approx.)  |
|------------------------------|------------|--|------------------|--|---|
| +                            | --         | Signal name  | Input/<br>Output |  |   |
| 109<br>(BR)                  | 128<br>(B) | PNP signal   | Input            | [Ignition switch: ON]<br>• Selector lever: P or N  | BATTERY VOLTAGE<br>(11 - 14 V)  |
|                              |            |  |                  | [Ignition switch: ON]<br>• Selector lever: Except above  | 0 V   |
| 110<br>(V)                   | 128<br>(B) | Engine speed output signal   | Output           | [Engine is running]<br>• Warm-up condition<br>• Idle speed<br><b>NOTE:</b><br>The pulse cycle changes depending on rpm at idle | 1 V★<br><br>2V/div JMBIA0076GB |
|                              |            |  |                  | [Engine is running]<br>• Engine speed is 2,000 rpm   | 1 V★<br><br>2V/div JMBIA0077GB |
| 112<br>(V)                   | —          | Sensor ground<br>(EVAP control system pressure sensor, Refrigerant pressure sensor)      | —                | —  | —   |
| 113<br>(P)                   | —          | CAN communication line   | Input/<br>Output | —  | —   |
| 114<br>(L)                   | —          | CAN communication line   | Input/<br>Output | —  | —   |
| 117<br>(V)                   | 128<br>(B) | Data link connector  | Input/<br>Output | —  | —   |
| 121<br>(G)                   | 128<br>(B) | EVAP canister vent control valve   | Output           | [Ignition switch: ON]  | BATTERY VOLTAGE<br>(11 - 14 V)  |
| 122<br>(P)                   | 128<br>(B) | Stop lamp switch   | Input            | [Ignition switch: OFF]<br>• Brake pedal: Fully released  | 0 V   |
|                              |            |  |                  | [Ignition switch: OFF]<br>• Brake pedal: Slightly depressed  | BATTERY VOLTAGE<br>(11 - 14 V)  |
| 123<br>(B)<br>124<br>(B)     | —          | ECM ground   | —                | —  | —   |
| 125<br>(SB)                  | 128<br>(B) | Power supply for ECM   | Input            | [Ignition switch: ON]  | BATTERY VOLTAGE<br>(11 - 14 V)  |
| 126<br>(BR)                  | 128<br>(B) | ICC brake switch (models with ICC system)<br>ASCD brake switch (models with ASCD system) | Input            | [Ignition switch: ON]<br>• Brake pedal: Slightly depressed   | 0 V   |
|                              |            |  |                  | [Ignition switch: ON]<br>• Brake pedal: Fully released   | BATTERY VOLTAGE<br>(11 - 14 V)  |
| 127<br>(B)<br>128<br>(B)     | —          | ECM ground   | —                | —  | —   |

★: Average voltage for pulse signal (Actual pulse signal can be confirmed by oscilloscope.)

\*1: This may vary depending on internal resistance of the tester.



# ECM

[VQ37VHR FOR MEXICO]

## < ECU DIAGNOSIS INFORMATION >

\*2: Before measuring the terminal voltage, confirm that the battery is fully charged. Refer to [PG-135. "How to Handle Battery"](#).

\*3: With ICC

\*4: Without ICC

### Fail safe

INFOID:000000007729711

### NON DTC RELATED ITEM

| Engine operating condition in fail-safe mode                       | Detected items                     | Remarks   | Reference page         |
|--|------------------------------------|---|------------------------|
| Engine speed will not rise more than 2,500 rpm due to the fuel cut | Malfunction indicator lamp circuit | When there is an open circuit on MIL circuit, the ECM cannot warn the driver by illuminating MIL when there is malfunction on engine control system.<br>Therefore, when electrical controlled throttle and part of ECM related diagnoses are continuously detected as NG for 5 trips, ECM warns the driver that engine control system malfunctions and MIL circuit is open by means of operating the fail-safe function.<br>The fail-safe function also operates when above diagnoses except MIL circuit are detected and demands the driver to repair the malfunction. | <a href="#">EC-957</a> |

### DTC RELATED ITEM

| DTC No.  | Detected items                            | Engine operating condition in fail-safe mode  |  |
|--|---|---|--|
| U1003<br>U1024   | Can communication circuit                 | VVEL actuator motor relay is turned off, and VVEL value is become at a minimum angle.<br>Engine speed will not rise more than 3,500 rpm due to the fuel cut.  |  |
| P0011<br>P0021   | Intake valve timing control               | The signal is not energized to the intake valve timing control solenoid valve and the valve control does not function.  |  |
| P0102<br>P0103<br>P010C<br>P010D   | Mass air flow sensor circuit              | Engine speed will not rise more than 2,400 rpm due to the fuel cut.   |  |
| P0117<br>P0118   | Engine coolant temperature sensor circuit | Engine coolant temperature will be determined by ECM based on the following condition.<br>CONSULT displays the engine coolant temperature decided by ECM.   |  |
|  |   | Condition   | Engine coolant temperature decided (CONSULT display) |
|  |   | Just as ignition switch is turned ON or START   | 40°C (104°F)   |
|  |   | Approx 4 minutes or more after engine starting  | 80°C (176°F)   |
|  |   | Except as shown above   | 40 - 80°C (104 - 176°F)<br>(Depends on the time)     |
|  |   | When the fail-safe system for engine coolant temperature sensor is activated, the cooling fan operates while engine is running.   |  |
| P0122<br>P0123<br>P0222<br>P0223<br>P0227<br>P0228<br>P1239<br>P2132<br>P2133<br>P2135 | Throttle position sensor                  | The ECM controls the electric throttle control actuator in regulating the throttle opening in order for the idle position to be within +10 degrees.<br>The ECM regulates the opening speed of the throttle valve to be slower than the normal condition.<br>Therefore, the acceleration will be poor. |  |
| P0500  | Vehicle speed sensor                      | The cooling fan operates (Highest) while engine is running.   |  |
| P0524  | Engine oil pressure                       | The signal is not energized to the intake valve timing control solenoid valve and the valve control does not function.<br>Engine speed will not rise more than 2,400 rpm due to the fuel cut.   |  |

# ECM

## < ECU DIAGNOSIS INFORMATION >

**[VQ37VHR FOR MEXICO]**

| DTC No.                                   | Detected items                     | Engine operating condition in fail-safe mode   |                   |
|---|------------------------------------|--|-------------------|
| P0605                                     | ECM                                | (When ECM calculation function is malfunctioning:<br>ECM stops the electric throttle control actuator control, throttle valve is maintained at a fixed opening (approx. 5 degrees) by the return spring.<br>ECM deactivates ASCD operation.  |                   |
| P0607                                     | ECM                                | VVEL actuator motor relay is turned off, and VVEL value is become at a minimum angle.<br>Engine speed will not rise more than 2,500 rpm due to the fuel cut.   |                   |
| P0643                                     | Sensor power supply                | ECM stops the electric throttle control actuator control, throttle valve is maintained at a fixed opening (approx. 5 degrees) by the return spring.  |                   |
| P1087<br>P1088                            | VVEL control function              | VVEL of normal bank is controlled at VVEL angle of abnormal bank.<br>Engine speed will not rise more than 3,500 rpm due to the fuel cut.   |                   |
| P1089<br>P1092                            | VVEL control shaft position sensor | VVEL value is maintained at a fixed angle.<br>Engine speed will not rise more than 3,500 rpm due to the fuel cut   |                   |
| P1608                                     | VVEL control shaft position sensor | VVEL actuator motor relay is turned off, and VVEL value is become at a minimum angle.<br>Engine speed will not rise more than 3,500 rpm due to the fuel cut  |                   |
| P1090<br>P1093                            | VVEL actuator motor                | VVEL of normal bank is controlled at VVEL angle of abnormal bank.<br>Engine speed will not rise more than 3,500 rpm due to the fuel cut.<br><br>VVEL actuator motor relay is turned off, and VVEL value is become at a minimum angle.<br>Engine speed will not rise more than 3,500 rpm due to the fuel cut.   |                   |
| P1091                                     | VVEL actuator motor relay          | VVEL actuator motor relay is turned off, and VVEL value is become at a minimum angle.<br>Engine speed will not rise more than 3,500 rpm due to the fuel cut.   |                   |
| P1233<br>P2101                            | Electric throttle control function | ECM stops the electric throttle control actuator control, throttle valve is maintained at a fixed opening (approx. 5 degrees) by the return spring.  |                   |
| P1236<br>P2118                            | Throttle control motor             | ECM stops the electric throttle control actuator control, throttle valve is maintained at a fixed opening (approx. 5 degrees) by the return spring.  |                   |
| P1238<br>P2119                            | Electric throttle control actuator | (When electric throttle control actuator does not function properly due to the return spring malfunction:)<br>ECM controls the electric throttle actuator by regulating the throttle opening around the idle position. The engine speed will not rise more than 2,000 rpm.<br><br>(When throttle valve opening angle in fail-safe mode is not in specified range:)<br>ECM controls the electric throttle control actuator by regulating the throttle opening to 20 degrees or less.<br><br>(When ECM detects the throttle valve is stuck open:)<br>While the vehicle is being driven, it slows down gradually because of fuel cut. After the vehicle stops, the engine stalls.<br>The engine can restart in N or P position, and engine speed will not exceed 1,000 rpm or more. |                   |
| P1290<br>P2100<br>P2103                   | Throttle control motor relay       | ECM stops the electric throttle control actuator control, throttle valve is maintained at a fixed opening (approx. 5 degrees) by the return spring.  |                   |
| P1606                                     | VVEL control module                | VVEL actuator motor relay is turned off, and VVEL value is become at a minimum angle.<br>Engine speed will not rise more than 3,500 rpm due to the fuel cut.   |                   |
| P1805                                     | Brake switch                       | ECM controls the electric throttle control actuator by regulating the throttle opening to a small range.<br>Therefore, acceleration will be poor.  |                   |
|   |                                    | Vehicle condition  | Driving condition |
|   |                                    | When engine is idling  | Normal            |
|   |                                    | When accelerating  | Poor acceleration |
| P2122<br>P2123<br>P2127<br>P2128<br>P2138 | Accelerator pedal position sensor  | The ECM controls the electric throttle control actuator in regulating the throttle opening in order for the idle position to be within +10 degrees.<br>The ECM regulates the opening speed of the throttle valve to be slower than the normal condition.<br>Therefore, the acceleration will be poor.  |                   |

## DTC Inspection Priority Chart

If some DTCs are displayed at the same time, perform inspections one by one based on the following priority chart.

| Priority | Detected items (DTC)   |                                 |
|----------|--|---------------------------------|
| 1        | <ul style="list-style-type: none"> <li>• U0101 U1001 U1003 CAN communication line</li> <li>• U1024 VVEL CAN communication line</li> <li>• P0102 P0103 P010C P010D Mass air flow sensor</li> <li>• P0112 P0113 Intake air temperature sensor</li> <li>• P0117 P0118 Engine coolant temperature sensor</li> <li>• P0122 P0123 P0222 P0223 P0227 P0228 P1225 P1226 P1234 P1235 P1239 P2132 P2133 P2135 Throttle position sensor</li> <li>• P0182 P0183 Fuel tank temperature sensor</li> <li>• P0197 P0198 Engine oil temperature sensor</li> <li>• P0327 P0328 P0332 P0333 Knock sensor</li> <li>• P0335 Crankshaft position sensor (POS)</li> <li>• P0340 P0345 Camshaft position sensor (PHASE)</li> <li>• P0500 Vehicle speed sensor</li> <li>• P0605 P0607 ECM</li> <li>• P0643 Sensor power supply</li> <li>• P0700 TCM</li> <li>• P0705 Transmission range switch</li> <li>• P0850 Park/neutral position (PNP) switch</li> <li>• P1089 P1092 P1608 VVEL control shaft position sensor</li> <li>• P1606 P1607 VVEL control module</li> <li>• P1550 P1551 P1552 P1553 P1554 Battery current sensor</li> <li>• P1556 P1557 Battery temperature sensor</li> <li>• P1610 - P1615 NATS</li> <li>• P2122 P2123 P2127 P2128 P2138 Accelerator pedal position sensor</li> </ul>     | A<br>C<br>D<br>E<br>F<br>G<br>H |
| 2        | <ul style="list-style-type: none"> <li>• P0031 P0032 P0051 P0052 Air fuel ratio (A/F) sensor 1 heater</li> <li>• P0037 P0038 P0057 P0058 Heated oxygen sensor 2 heater</li> <li>• P0075 P0081 Intake valve timing control solenoid valve</li> <li>• P0130 P0131 P0132 P0133 P0150 P0151 P0152 P0153 P2A00 P2A03 Air fuel ratio (A/F) sensor 1</li> <li>• P0137 P0138 P0139 P0157 P0158 P0159 Heated oxygen sensor 2</li> <li>• P0444 P0445 EVAP canister purge volume control solenoid valve</li> <li>• P0447 EVAP canister vent control valve</li> <li>• P0452 P0453 EVAP control system pressure sensor</li> <li>• P0550 Power steering pressure sensor</li> <li>• P0603 ECM power supply</li> <li>• P0710 P0717 P0720 P0731 P0732 P0733 P0734 P0735 P0740 P0744 P0745 P0750 P0775 P0780 P0795 P1730 P1734 P2713 P2722 P2731 P2807 A/T related sensors, solenoid valves and switches</li> <li>• P1087 P1088 VVEL system</li> <li>• P1090 P1093 VVEL actuator motor</li> <li>• P1091 VVEL actuator motor relay</li> <li>• P1217 Engine over temperature (OVERHEAT)</li> <li>• P1233 P2101 Electric throttle control function</li> <li>• P1236 P2118 Throttle control motor</li> <li>• P1290 P2100 P2103 Throttle control motor relay</li> <li>• P1805 Brake switch</li> </ul> | I<br>J<br>K<br>L<br>M           |
| 3        | <ul style="list-style-type: none"> <li>• P0011 P0021 Intake valve timing control</li> <li>• P0171 P0172 P0174 P0175 Fuel injection system function</li> <li>• P0300 - P0306 Misfire</li> <li>• P0420 P0430 Three way catalyst function</li> <li>• P0524 Engine oil pressure</li> <li>• P100A P100B VVEL system</li> <li>• P1211 TCS control unit</li> <li>• P1212 TCS communication line</li> <li>• P1238 P2119 Electric throttle control actuator</li> <li>• P1564 ICC steering switch / ASCD steering switch</li> <li>• P1568 ICC command value</li> <li>• P1572 ICC brake switch / ASCD brake switch</li> <li>• P1574 ICC vehicle speed sensor / ASCD vehicle speed sensor</li> </ul>   | N<br>O<br>P                     |

## DTC Index

×:Applicable —: Not applicable

| DTC*1            |             | Items<br>(CONSULT screen terms)                                       | SRT<br>code | Trip                                     | MIL               | Reference page         |
|------------------|-------------|---|-------------|--|-------------------|------------------------|
| CONSULT<br>GST*2 | ECM*3       |   |             |  |                   |                        |
| U0101            | 0101*4      | CAN COMM CIRCUIT  | —           | 1  | ×                 | <a href="#">EC-687</a> |
| U1001            | 1001*4      | CAN COMM CIRCUIT  | —           | 2<br>(with ASCD)<br>1 or 2<br>(with ICC) | —                 | <a href="#">EC-688</a> |
| U1003            | 1003        | CAN COMM CIRCUIT  | —           | 2  | —                 | <a href="#">EC-689</a> |
| U1024            | 1024        | VVEL CAN COMM CIRCUIT   | —           | 1  | ×                 | <a href="#">EC-691</a> |
| <b>P0000</b>     | <b>0000</b> | <b>NO DTC IS DETECTED.<br/>FURTHER TESTING MAY BE RE-<br/>QUIRED.</b> | —           | —  | <b>Flashing*6</b> | —                      |
| P0011            | 0011        | INT/V TIM CONT-B1   | —           | 2  | ×                 | <a href="#">EC-693</a> |
| P0021            | 0021        | INT/V TIM CONT-B2   | —           | 2  | ×                 | <a href="#">EC-693</a> |
| P0031            | 0031        | A/F SEN1 HTR (B1)   | —           | 2  | ×                 | <a href="#">EC-697</a> |
| P0032            | 0032        | A/F SEN1 HTR (B1)   | —           | 2  | ×                 | <a href="#">EC-697</a> |
| P0037            | 0037        | HO2S2 HTR (B1)  | —           | 2  | ×                 | <a href="#">EC-700</a> |
| P0038            | 0038        | HO2S2 HTR (B1)  | —           | 2  | ×                 | <a href="#">EC-700</a> |
| P0051            | 0051        | A/F SEN1 HTR (B2)   | —           | 2  | ×                 | <a href="#">EC-697</a> |
| P0052            | 0052        | A/F SEN1 HTR (B2)   | —           | 2  | ×                 | <a href="#">EC-697</a> |
| P0057            | 0057        | HO2S2 HTR (B2)  | —           | 2  | ×                 | <a href="#">EC-700</a> |
| P0058            | 0058        | HO2S2 HTR (B2)  | —           | 2  | ×                 | <a href="#">EC-700</a> |
| P0075            | 0075        | INT/V TIM V/CIR-B1  | —           | 2  | ×                 | <a href="#">EC-703</a> |
| P0081            | 0081        | INT/V TIM V/CIR-B2  | —           | 2  | ×                 | <a href="#">EC-703</a> |
| P0102            | 0102        | MAF SEN/CIRCUIT-B1  | —           | 1  | ×                 | <a href="#">EC-706</a> |
| P0103            | 0103        | MAF SEN/CIRCUIT-B1  | —           | 1  | ×                 | <a href="#">EC-706</a> |
| P010C            | 010C        | MAF SEN/CIRCUIT-B2  | —           | 1  | ×                 | <a href="#">EC-706</a> |
| P010D            | 010D        | MAF SEN/CIRCUIT-B2  | —           | 1  | ×                 | <a href="#">EC-706</a> |
| P0112            | 0112        | IAT SEN/CIRCUIT-B1  | —           | 2  | ×                 | <a href="#">EC-712</a> |
| P0113            | 0113        | IAT SEN/CIRCUIT-B1  | —           | 2  | ×                 | <a href="#">EC-712</a> |
| P0117            | 0117        | ECT SEN/CIRC  | —           | 1  | ×                 | <a href="#">EC-714</a> |
| P0118            | 0118        | ECT SEN/CIRC  | —           | 1  | ×                 | <a href="#">EC-714</a> |
| P0122            | 0122        | TP SEN 2/CIRC-B1  | —           | 1  | ×                 | <a href="#">EC-716</a> |
| P0123            | 0123        | TP SEN 2/CIRC-B1  | —           | 1  | ×                 | <a href="#">EC-716</a> |
| P0130            | 0130        | A/F SENSOR1 (B1)  | —           | 2  | ×                 | <a href="#">EC-719</a> |
| P0131            | 0131        | A/F SENSOR1 (B1)  | —           | 2  | ×                 | <a href="#">EC-723</a> |
| P0132            | 0132        | A/F SENSOR1 (B1)  | —           | 2  | ×                 | <a href="#">EC-726</a> |
| P0133            | 0133        | A/F SENSOR1 (B1)  | ×           | 2  | ×                 | <a href="#">EC-729</a> |
| P0137            | 0137        | HO2S2 (B1)  | ×           | 2  | ×                 | <a href="#">EC-734</a> |
| P0138            | 0138        | HO2S2 (B1)  | ×           | 2  | ×                 | <a href="#">EC-740</a> |
| P0139            | 0139        | HO2S2 (B1)  | ×           | 2  | ×                 | <a href="#">EC-748</a> |
| P0150            | 0150        | A/F SENSOR1 (B2)  | —           | 2  | ×                 | <a href="#">EC-719</a> |
| P0151            | 0151        | A/F SENSOR1 (B2)  | —           | 2  | ×                 | <a href="#">EC-723</a> |

## ECM

&lt; ECU DIAGNOSIS INFORMATION &gt;

[VQ37VHR FOR MEXICO]

| DTC*1            |       | Items<br>(CONSULT screen terms) | SRT<br>code | Trip   | MIL | Reference page         |
|------------------|-------|---------------------------------|-------------|--------|-----|------------------------|
| CONSULT<br>GST*2 | ECM*3 |                                 |             |        |     |                        |
| P0152            | 0152  | A/F SENSOR1 (B2)                | —           | 2      | ×   | <a href="#">EC-726</a> |
| P0153            | 0153  | A/F SENSOR1 (B2)                | ×           | 2      | ×   | <a href="#">EC-729</a> |
| P0157            | 0157  | HO2S2 (B2)                      | ×           | 2      | ×   | <a href="#">EC-734</a> |
| P0158            | 0158  | HO2S2 (B2)                      | ×           | 2      | ×   | <a href="#">EC-740</a> |
| P0159            | 0159  | HO2S2 (B2)                      | ×           | 2      | ×   | <a href="#">EC-748</a> |
| P0171            | 0171  | FUEL SYS-LEAN-B1                | —           | 2      | ×   | <a href="#">EC-754</a> |
| P0172            | 0172  | FUEL SYS-RICH-B1                | —           | 2      | ×   | <a href="#">EC-758</a> |
| P0174            | 0174  | FUEL SYS-LEAN-B2                | —           | 2      | ×   | <a href="#">EC-754</a> |
| P0175            | 0175  | FUEL SYS-RICH-B2                | —           | 2      | ×   | <a href="#">EC-758</a> |
| P0182            | 0182  | FTT SEN/CIRCUIT                 | —           | 2      | ×   | <a href="#">EC-762</a> |
| P0183            | 0183  | FTT SEN/CIRCUIT                 | —           | 2      | ×   | <a href="#">EC-762</a> |
| P0197            | 0197  | EOT SEN/CIRC                    | —           | 2      | ×   | <a href="#">EC-765</a> |
| P0198            | 0198  | EOT SEN/CIRC                    | —           | 2      | ×   | <a href="#">EC-765</a> |
| P0222            | 0222  | TP SEN 1/CIRC-B1                | —           | 1      | ×   | <a href="#">EC-767</a> |
| P0223            | 0223  | TP SEN 1/CIRC-B1                | —           | 1      | ×   | <a href="#">EC-767</a> |
| P0227            | 0227  | TP SEN 2/CIRC-B2                | —           | 1      | ×   | <a href="#">EC-716</a> |
| P0228            | 0228  | TP SEN 2/CIRC-B2                | —           | 1      | ×   | <a href="#">EC-716</a> |
| P0300            | 0300  | MULTI CYL MISFIRE               | —           | 1 or 2 | ×   | <a href="#">EC-770</a> |
| P0301            | 0301  | CYL 1 MISFIRE                   | —           | 1 or 2 | ×   | <a href="#">EC-770</a> |
| P0302            | 0302  | CYL 2 MISFIRE                   | —           | 1 or 2 | ×   | <a href="#">EC-770</a> |
| P0303            | 0303  | CYL 3 MISFIRE                   | —           | 1 or 2 | ×   | <a href="#">EC-770</a> |
| P0304            | 0304  | CYL 4 MISFIRE                   | —           | 1 or 2 | ×   | <a href="#">EC-770</a> |
| P0305            | 0305  | CYL 5 MISFIRE                   | —           | 1 or 2 | ×   | <a href="#">EC-770</a> |
| P0306            | 0306  | CYL 6 MISFIRE                   | —           | 1 or 2 | ×   | <a href="#">EC-770</a> |
| P0327            | 0327  | KNOCK SEN/CIRC-B1               | —           | 2      | —   | <a href="#">EC-776</a> |
| P0328            | 0328  | KNOCK SEN/CIRC-B1               | —           | 2      | —   | <a href="#">EC-776</a> |
| P0332            | 0332  | KNOCK SEN/CIRC-B2               | —           | 2      | —   | <a href="#">EC-776</a> |
| P0333            | 0333  | KNOCK SEN/CIRC-B2               | —           | 2      | —   | <a href="#">EC-776</a> |
| P0335            | 0335  | CKP SEN/CIRCUIT                 | —           | 2      | ×   | <a href="#">EC-779</a> |
| P0340            | 0340  | CMP SEN/CIRC-B1                 | —           | 2      | ×   | <a href="#">EC-783</a> |
| P0345            | 0345  | CMP SEN/CIRC-B2                 | —           | 2      | ×   | <a href="#">EC-783</a> |
| P0420            | 0420  | TW CATALYST SYS-B1              | ×           | 2      | ×   | <a href="#">EC-788</a> |
| P0430            | 0430  | TW CATALYST SYS-B2              | ×           | 2      | ×   | <a href="#">EC-788</a> |
| P0444            | 0444  | PURG VOLUME CONT/V              | —           | 2      | ×   | <a href="#">EC-793</a> |
| P0445            | 0445  | PURG VOLUME CONT/V              | —           | 2      | ×   | <a href="#">EC-793</a> |
| P0447            | 0447  | VENT CONTROL VALVE              | —           | 2      | ×   | <a href="#">EC-796</a> |
| P0452            | 0452  | EVAP SYS PRES SEN               | —           | 2      | ×   | <a href="#">EC-800</a> |
| P0453            | 0453  | EVAP SYS PRES SEN               | —           | 2      | ×   | <a href="#">EC-805</a> |
| P0500            | 0500  | VEHICLE SPEED SENSOR A*5        | —           | 2      | ×   | <a href="#">EC-810</a> |
| P0524            | 0524  | ENGINE OIL PRESSURE             | —           | 2      | ×   | <a href="#">EC-812</a> |
| P0550            | 0550  | PW ST P SEN/CIRC                | —           | 2      | —   | <a href="#">EC-815</a> |
| P0603            | 0603  | ECM BACK UP/CIRCUIT             | —           | 2      | ×   | <a href="#">EC-817</a> |

# ECM

< ECU DIAGNOSIS INFORMATION >

[VQ37VHR FOR MEXICO]

| DTC*1            |       | Items<br>(CONSULT screen terms) | SRT<br>code | Trip   | MIL    | Reference page         |
|------------------|-------|---------------------------------|-------------|--------|--------|------------------------|
| CONSULT<br>GST*2 | ECM*3 |                                 |             |        |        |                        |
| P0605            | 0605  | ECM                             | —           | 1 or 2 | × or — | <a href="#">EC-819</a> |
| P0607            | 0607  | ECM                             | —           | 1      | ×      | <a href="#">EC-821</a> |
| P0643            | 0643  | SENSOR POWER/CIRC               | —           | 1      | ×      | <a href="#">EC-822</a> |
| P0705            | 0705  | T/M RANGE SENSOR A              | —           | 2      | ×      | <a href="#">TM-102</a> |
| P0710            | 0710  | FLUID TEMP SENSOR A             | —           | 2      | ×      | <a href="#">TM-103</a> |
| P0717            | 0717  | INPUT SPEED SENSOR A            | —           | 2      | ×      | <a href="#">TM-105</a> |
| P0720            | 0720  | OUTPUT SPEED SENSOR*5           | —           | 2      | ×      | <a href="#">TM-106</a> |
| P0729            | 0729  | 6GR INCORRECT RATIO             | —           | 2      | ×      | <a href="#">TM-110</a> |
| P0730            | 0730  | INCORRECT GR RATIO              | —           | 2      | ×      | <a href="#">TM-112</a> |
| P0731            | 0731  | 1GR INCORRECT RATIO             | —           | 2      | ×      | <a href="#">TM-114</a> |
| P0732            | 0732  | 2GR INCORRECT RATIO             | —           | 2      | ×      | <a href="#">TM-116</a> |
| P0733            | 0733  | 3GR INCORRECT RATIO             | —           | 2      | ×      | <a href="#">TM-118</a> |
| P0734            | 0734  | 4GR INCORRECT RATIO             | —           | 2      | ×      | <a href="#">TM-120</a> |
| P0735            | 0735  | 5GR INCORRECT RATIO             | —           | 2      | ×      | <a href="#">TM-122</a> |
| P0740            | 0740  | TORQUE CONVERTER                | —           | 2      | ×      | <a href="#">TM-124</a> |
| P0744            | 0744  | TORQUE CONVERTER                | —           | 2      | ×      | <a href="#">TM-125</a> |
| P0745            | 0745  | PC SOLENOID A                   | —           | 2      | ×      | <a href="#">TM-127</a> |
| P0750            | 0750  | SHIFT SOLENOID A                | —           | 2      | ×      | <a href="#">TM-128</a> |
| P0775            | 0775  | PC SOLENOID B                   | —           | 2      | ×      | <a href="#">TM-129</a> |
| P0780            | 0780  | SHIFT                           | —           | 1      | ×      | <a href="#">TM-130</a> |
| P0795            | 0795  | PC SOLENOID C                   | —           | 2      | ×      | <a href="#">TM-132</a> |
| P0850            | 0850  | P-N POS SW/CIRCUIT              | —           | 2      | ×      | <a href="#">EC-825</a> |
| P100A            | 100A  | VVEL SYSTEM-B1                  | —           | 2      | ×      | <a href="#">EC-828</a> |
| P100B            | 100B  | VVEL SYSTEM-B2                  | —           | 2      | ×      | <a href="#">EC-828</a> |
| P1087            | 1087  | VVEL SYSTEM-B1                  | —           | 1      | ×      | <a href="#">EC-832</a> |
| P1088            | 1088  | VVEL SYSTEM-B2                  | —           | 1      | ×      | <a href="#">EC-832</a> |
| P1089            | 1089  | VVEL POS SEN/CIRC-B1            | —           | 1      | ×      | <a href="#">EC-833</a> |
| P1090            | 1090  | VVEL ACTR MOT-B1                | —           | 1      | ×      | <a href="#">EC-836</a> |
| P1091            | 1091  | VVEL ACTR MOT PWR               | —           | 1 or 2 | ×      | <a href="#">EC-840</a> |
| P1092            | 1092  | VVEL POS SEN/CIRC-B2            | —           | 1      | ×      | <a href="#">EC-833</a> |
| P1093            | 1093  | VVEL ACTR MOT-B2                | —           | 1      | ×      | <a href="#">EC-836</a> |
| P1211            | 1211  | TCS C/U FUNCTN                  | —           | 2      | —      | <a href="#">EC-843</a> |
| P1212            | 1212  | TCS/CIRC                        | —           | 2      | —      | <a href="#">EC-844</a> |
| P1217            | 1217  | ENG OVER TEMP                   | —           | 1      | ×      | <a href="#">EC-845</a> |
| P1225            | 1225  | CTP LEARNING-B1                 | —           | 2      | —      | <a href="#">EC-849</a> |
| P1226            | 1226  | CTP LEARNING-B1                 | —           | 2      | —      | <a href="#">EC-851</a> |
| P1233            | 1233  | ETC FNCTN/CIRC-B2               | —           | 1      | ×      | <a href="#">EC-853</a> |
| P1234            | 1234  | CTP LEARNING-B2                 | —           | 2      | —      | <a href="#">EC-849</a> |
| P1235            | 1235  | CTP LEARNING-B2                 | —           | 2      | —      | <a href="#">EC-851</a> |
| P1236            | 1236  | ETC MOT-B2                      | —           | 1      | ×      | <a href="#">EC-857</a> |
| P1238            | 1238  | ETC ACTR-B2                     | —           | 1      | ×      | <a href="#">EC-860</a> |
| P1239            | 1239  | TP SENSOR-B2                    | —           | 1      | ×      | <a href="#">EC-862</a> |

# ECM

< ECU DIAGNOSIS INFORMATION >

[VQ37VHR FOR MEXICO]

| DTC*1            |       | Items<br>(CONSULT screen terms) | SRT<br>code | Trip   | MIL    | Reference page  |
|------------------|-------|---------------------------------|-------------|--------|--------|---|
| CONSULT<br>GST*2 | ECM*3 |                                 |             |        |        |   |
| P1290            | 1290  | ETC MOT PWR-B2                  | —           | 1      | ×      | <a href="#">EC-865</a>  |
| P1550            | 1550  | BAT CURRENT SENSOR              | —           | 2      | —      | <a href="#">EC-867</a>  |
| P1551            | 1551  | BAT CURRENT SENSOR              | —           | 2      | —      | <a href="#">EC-871</a>  |
| P1552            | 1552  | BAT CURRENT SENSOR              | —           | 2      | —      | <a href="#">EC-871</a>  |
| P1553            | 1553  | BAT CURRENT SENSOR              | —           | 2      | —      | <a href="#">EC-875</a>  |
| P1554            | 1554  | BAT CURRENT SENSOR              | —           | 2      | —      | <a href="#">EC-879</a>  |
| P1556            | 1556  | BAT TMP SEN/CIRC                | —           | 2      | —      | <a href="#">EC-883</a>  |
| P1557            | 1557  | BAT TMP SEN/CIRC                | —           | 2      | —      | <a href="#">EC-883</a>  |
| P1564            | 1564  | ASCD SW                         | —           | 1      | —      | <a href="#">EC-886</a><br>(with ASCD)<br><a href="#">EC-889</a><br>(with ICC) |
| P1568            | 1568  | ICC COMMAND VALUE               | —           | 1      | —      | <a href="#">EC-893</a>  |
| P1572            | 1572  | ASCD BRAKE SW                   | —           | 1      | —      | <a href="#">EC-894</a><br>(with ASCD)<br><a href="#">EC-900</a><br>(with ICC) |
| P1574            | 1574  | ASCD VHL SPD SEN                | —           | 1      | —      | <a href="#">EC-906</a><br>(with ASCD)<br><a href="#">EC-908</a><br>(with ICC) |
| P1606            | 1606  | VVEL CONTROL MODULE             | —           | 1 or 2 | × or — | <a href="#">EC-910</a>  |
| P1607            | 1607  | VVEL CONTROL MODULE             | —           | 1      | ×      | <a href="#">EC-911</a>  |
| P1608            | 1608  | VVEL SENSOR POWER/CIRC          | —           | 1      | ×      | <a href="#">EC-912</a>  |
| P1610            | 1610  | LOCK MODE                       | —           | 2      | —      | <a href="#">SEC-41</a>  |
| P1611            | 1611  | ID DISCARD, IMM-ECM             | —           | 2      | —      | <a href="#">SEC-42</a>  |
| P1612            | 1612  | CHAIN OF ECM-IMMU               | —           | 2      | —      | <a href="#">SEC-43</a>  |
| P1614            | 1614  | CHAIN OF IMMU-KEY               | —           | 2      | —      | <a href="#">SEC-44</a>  |
| P1730            | 1730  | INTERLOCK                       | —           | 2      | ×      | <a href="#">TM-136</a>  |
| P1734            | 1734  | 7GR INCORRECT RATIO             | —           | 2      | ×      | <a href="#">TM-138</a>  |
| P1805            | 1805  | BRAKE SW/CIRCUIT                | —           | 2      | —      | <a href="#">EC-915</a>  |
| P1806            | 1806  | BRAKE VACUUM SEN                | —           | 2      | ×      | <a href="#">BRC-113</a>   |
| P2100            | 2100  | ETC MOT PWR-B1                  | —           | 1      | ×      | <a href="#">EC-865</a>  |
| P2101            | 2101  | ETC FNCTN/CIRC-B1               | —           | 1      | ×      | <a href="#">EC-853</a>  |
| P2103            | 2103  | ETC MOT PWR                     | —           | 1      | ×      | <a href="#">EC-865</a>  |
| P2118            | 2118  | ETC MOT-B1                      | —           | 1      | ×      | <a href="#">EC-857</a>  |
| P2119            | 2119  | ETC ACTR-B1                     | —           | 1      | ×      | <a href="#">EC-860</a>  |
| P2122            | 2122  | APP SEN 1/CIRC                  | —           | 1      | ×      | <a href="#">EC-918</a>  |
| P2123            | 2123  | APP SEN 1/CIRC                  | —           | 1      | ×      | <a href="#">EC-918</a>  |
| P2127            | 2127  | APP SEN 2/CIRC                  | —           | 1      | ×      | <a href="#">EC-922</a>  |
| P2128            | 2128  | APP SEN 2/CIRC                  | —           | 1      | ×      | <a href="#">EC-922</a>  |
| P2132            | 2132  | TP SEN 1/CIRC-B2                | —           | 1      | ×      | <a href="#">EC-767</a>  |
| P2133            | 2133  | TP SEN 1/CIRC-B2                | —           | 1      | ×      | <a href="#">EC-767</a>  |
| P2135            | 2135  | TP SENSOR-B1                    | —           | 1      | ×      | <a href="#">EC-862</a>  |
| P2138            | 2138  | APP SENSOR                      | —           | 1      | ×      | <a href="#">EC-927</a>  |

A

EC

C

D

E

F

G

H

I

J

K

L

M

N

O

P

# ECM

< ECU DIAGNOSIS INFORMATION >

[VQ37VHR FOR MEXICO]

| DTC*1            |       | Items<br>(CONSULT screen terms) | SRT<br>code | Trip | MIL | Reference page         |
|------------------|-------|---------------------------------|-------------|------|-----|------------------------|
| CONSULT<br>GST*2 | ECM*3 |                                 |             |      |     |                        |
| P2713            | 2713  | PC SOLENOID D                   | —           | 2    | ×   | <a href="#">TM-146</a> |
| P2722            | 2722  | PC SOLENOID E                   | —           | 2    | ×   | <a href="#">TM-147</a> |
| P2731            | 2731  | PC SOLENOID F                   | —           | 2    | ×   | <a href="#">TM-148</a> |
| P2807            | 2807  | PC SOLENOID G                   | —           | 2    | ×   | <a href="#">TM-149</a> |
| P2A00            | 2A00  | A/F SENSOR1 (B1)                | —           | 2    | ×   | <a href="#">EC-932</a> |
| P2A03            | 2A03  | A/F SENSOR1 (B2)                | —           | 2    | ×   | <a href="#">EC-932</a> |

\*1: 1st trip DTC No. is the same as DTC No.

\*2: This number is prescribed by SAE J2012/ISO 15031-6.

\*3: In Diagnostic Test Mode II (Self-diagnostic results), this number is controlled by NISSAN.

\*4: The troubleshooting for this DTC needs CONSULT.

\*5: When the fail-safe operations for both self-diagnoses occur, the MIL illuminates.

\*6: When the ECM is in the mode that displays SRT status, MIL may blink. For the details, refer to “How to Display SRT Status”.

## Test Value and Test Limit

INFOID:000000007729714

The following is the information specified in Service \$06 of SAE J1979/ISO 15031-5.

The test value is a parameter used to determine whether a system/circuit diagnostic test is OK or NG while being monitored by the ECM during self-diagnosis. The test limit is a reference value which is specified as the maximum or minimum value and is compared with the test value being monitored.

These data (test value and test limit) are specified by On Board Monitor ID (OBDMID), Test ID (TID), Unit and Scaling ID and can be displayed on the GST screen.

The items of the test value and test limit will be displayed with GST screen which items are provided by the ECM. (e.g., if bank 2 is not applied on this vehicle, only the items of bank 1 are displayed)



# ECM

< ECU DIAGNOSIS INFORMATION >

[VQ37VHR FOR MEXICO]

| Item | OBD-MID | Self-diagnostic test item              | DTC   | Test value and Test limit (GST display) |                     | Description   |
|------|---------|--|-------|---|---------------------|---|
|      |         |  |       | TID                                     | Unit and Scaling ID |   |
| HO2S | 01H     | Air fuel ratio (A/F) sensor 1 (Bank 1) | P0131 | 83H                                     | 0BH                 | Minimum sensor output voltage for test cycle              |
|      |         |  | P0131 | 84H                                     | 0BH                 | Maximum sensor output voltage for test cycle              |
|      |         |  | P0130 | 85H                                     | 0BH                 | Minimum sensor output voltage for test cycle              |
|      |         |  | P0130 | 86H                                     | 0BH                 | Maximum sensor output voltage for test cycle              |
|      |         |  | P0133 | 87H                                     | 04H                 | Response rate: Response ratio (lean to rich)              |
|      |         |  | P0133 | 88H                                     | 04H                 | Response rate: Response ratio (rich to lean)              |
|      |         |  | P2A00 | 89H                                     | 84H                 | The amount of shift in air fuel ratio                     |
|      |         |  | P2A00 | 8AH                                     | 84H                 | The amount of shift in air fuel ratio                     |
|      |         |  | P0130 | 8BH                                     | 0BH                 | Difference in sensor output voltage                       |
|      |         |  | P0133 | 8CH                                     | 83H                 | Response gain at the limited frequency                    |
|      |         |  | P014C | 8DH                                     | 04H                 | O2 sensor slow response - Rich to lean bank 1 sensor 1    |
|      |         |  | P014C | 8EH                                     | 04H                 | O2 sensor slow response - Rich to lean bank 1 sensor 1    |
|      |         |  | P014D | 8FH                                     | 84H                 | O2 sensor slow response - Lean to rich bank 1 sensor 1    |
|      |         |  | P014D | 90H                                     | 84H                 | O2 sensor slow response - Lean to rich bank 1 sensor 1    |
|      |         |  | P015A | 91H                                     | 01H                 | O2 sensor delayed response - Rich to lean bank 1 sensor 1 |
|      |         |  | P015A | 92H                                     | 01H                 | O2 sensor delayed response - Rich to lean bank 1 sensor 1 |
|      |         |  | P015B | 93H                                     | 01H                 | O2 sensor delayed response - Lean to rich bank 1 sensor 1 |
|      |         |  | P015B | 94H                                     | 01H                 | O2 sensor delayed response - Lean to rich bank 1 sensor 1 |
|      | 02H     | Heated oxygen sensor 2 (Bank 1)        | P0138 | 07H                                     | 0CH                 | Minimum sensor output voltage for test cycle              |
|      |         |  | P0137 | 08H                                     | 0CH                 | Maximum sensor output voltage for test cycle              |
|      |         |  | P0138 | 80H                                     | 0CH                 | Sensor output voltage                                     |
|      |         |  | P0139 | 81H                                     | 0CH                 | Difference in sensor output voltage                       |
|      |         |  | P0139 | 82H                                     | 11H                 | Rear O2 sensor delay response diagnosis                   |
|      | 03H     | Heated oxygen sensor 3 (Bank 1)        | P0143 | 07H                                     | 0CH                 | Minimum sensor output voltage for test cycle              |
|      |         |  | P0144 | 08H                                     | 0CH                 | Maximum sensor output voltage for test cycle              |
|      |         |  | P0146 | 80H                                     | 0CH                 | Sensor output voltage                                     |
|      |         |  | P0145 | 81H                                     | 0CH                 | Difference in sensor output voltage                       |

A  
EC  
C  
D  
E  
F  
G  
H  
I  
J  
K  
L  
M  
N  
O  
P

# ECM

< ECU DIAGNOSIS INFORMATION >

[VQ37VHR FOR MEXICO]

| Item | OBD-MID | Self-diagnostic test item              | DTC   | Test value and Test limit (GST display)                   |                     | Description   |
|------|---------|--|-------|---|---------------------|---|
|      |         |  |       | TID   | Unit and Scaling ID |   |
| HO2S | 05H     | Air fuel ratio (A/F) sensor 1 (Bank 2) | P0151 | 83H   | 0BH                 | Minimum sensor output voltage for test cycle              |
|      |         |  | P0151 | 84H   | 0BH                 | Maximum sensor output voltage for test cycle              |
|      |         |  | P0150 | 85H   | 0BH                 | Minimum sensor output voltage for test cycle              |
|      |         |  | P0150 | 86H   | 0BH                 | Maximum sensor output voltage for test cycle              |
|      |         |  | P0153 | 87H   | 04H                 | Response rate: Response ratio (lean to rich)              |
|      |         |  | P0153 | 88H   | 04H                 | Response rate: Response ratio (rich to lean)              |
|      |         |  | P2A03 | 89H   | 84H                 | The amount of shift in air fuel ratio                     |
|      |         |  | P2A03 | 8AH   | 84H                 | The amount of shift in air fuel ratio                     |
|      |         |  | P0150 | 8BH   | 0BH                 | Difference in sensor output voltage                       |
|      |         |  | P0153 | 8CH   | 83H                 | Response gain at the limited frequency                    |
|      |         |  | P014E | 8DH   | 04H                 | O2 sensor slow response - Rich to lean bank 2 sensor 1    |
|      |         |  | P014E | 8EH   | 04H                 | O2 sensor slow response - Rich to lean bank 2 sensor 1    |
|      |         |  | P014F | 8FH   | 84H                 | O2 sensor slow response - Lean to rich bank 2 sensor 1    |
|      |         |  | P014F | 90H   | 84H                 | O2 sensor slow response - Lean to rich bank 2 sensor 1    |
|      |         |  | P015C | 91H   | 01H                 | O2 sensor delayed response - Rich to lean bank 2 sensor 1 |
|      |         |  | P015C | 92H   | 01H                 | O2 sensor delayed response - Rich to lean bank 2 sensor 1 |
|      | P015D   | 93H                                    | 01H   | O2 sensor delayed response - Lean to rich bank 2 sensor 1 |                     |   |
|      | P015D   | 94H                                    | 01H   | O2 sensor delayed response - Lean to rich bank 2 sensor 1 |                     |   |
|      | 06H     | Heated oxygen sensor 2 (Bank 2)        | P0158 | 07H   | 0CH                 | Minimum sensor output voltage for test cycle              |
|      |         |  | P0157 | 08H   | 0CH                 | Maximum sensor output voltage for test cycle              |
|      |         |  | P0158 | 80H   | 0CH                 | Sensor output voltage                                     |
|      |         |  | P0159 | 81H   | 0CH                 | Difference in sensor output voltage                       |
|      |         |  | P0159 | 82H   | 11H                 | Rear O2 sensor delay response diagnosis                   |
|      | 07H     | Heated oxygen sensor 3 (Bank2)         | P0163 | 07H   | 0CH                 | Minimum sensor output voltage for test cycle              |
|      |         |  | P0164 | 08H   | 0CH                 | Maximum sensor output voltage for test cycle              |
|      |         |  | P0166 | 80H   | 0CH                 | Sensor output voltage                                     |
|      |         |  | P0165 | 81H   | 0CH                 | Difference in sensor output voltage                       |

# ECM

< ECU DIAGNOSIS INFORMATION >

[VQ37VHR FOR MEXICO]

| Item          | OBD-MID | Self-diagnostic test item           | DTC   | Test value and Test limit (GST display) |                     | Description  |
|---------------|---------|-------------------------------------|-------|---|---------------------|--|
|               |         |                                     |       | TID                                     | Unit and Scaling ID |  |
| CATA-<br>LYST | 21H     | Three way catalyst function (Bank1) | P0420 | 80H                                     | 01H                 | O2 storage index   |
|               |         |                                     | P0420 | 82H                                     | 01H                 | Switching time lag engine exhaust index value  |
|               |         |                                     | P2423 | 83H                                     | 0CH                 | Difference in 3rd O2 sensor output voltage   |
|               |         |                                     | P2423 | 84H                                     | 84H                 | O2 storage index in HC trap catalyst   |
|               | 22H     | Three way catalyst function (Bank2) | P0430 | 80H                                     | 01H                 | O2 storage index   |
|               |         |                                     | P0430 | 82H                                     | 01H                 | Switching time lag engine exhaust index value  |
|               |         |                                     | P2424 | 83H                                     | 0CH                 | Difference in 3rd O2 sensor output voltage   |
|               |         |                                     | P2424 | 84H                                     | 84H                 | O2 storage index in HC trap catalyst   |
| EGR<br>SYSTEM | 31H     | EGR function                        | P0400 | 80H                                     | 96H                 | Low flow faults: EGR temp change rate (short term)                                   |
|               |         |                                     | P0400 | 81H                                     | 96H                 | Low flow faults: EGR temp change rate (long term)                                    |
|               |         |                                     | P0400 | 82H                                     | 96H                 | Low flow faults: Difference between max EGR temp and EGR temp under idling condition |
|               |         |                                     | P0400 | 83H                                     | 96H                 | Low flow faults: Max EGR temp  |
|               |         |                                     | P1402 | 84H                                     | 96H                 | High Flow Faults: EGR temp increase rate   |
| VVT<br>SYSTEM | 35H     | VVT Monitor (Bank1)                 | P0011 | 80H                                     | 9DH                 | VTC intake function diagnosis (VTC alignment check diagnosis)                        |
|               |         |                                     | P0014 | 81H                                     | 9DH                 | VTC exhaust function diagnosis (VTC alignment check diagnosis)                       |
|               |         |                                     | P0011 | 82H                                     | 9DH                 | VTC intake function diagnosis (VTC drive failure diagnosis)                          |
|               |         |                                     | P0014 | 83H                                     | 9DH                 | VTC exhaust function diagnosis (VTC drive failure diagnosis)                         |
|               |         |                                     | P100A | 84H                                     | 10H                 | VEL slow response diagnosis  |
|               |         |                                     | P1090 | 85H                                     | 10H                 | VEL servo system diagnosis   |
|               | 36H     | VVT Monitor (Bank2)                 | P0021 | 80H                                     | 9DH                 | VTC intake function diagnosis (VTC alignment check diagnosis)                        |
|               |         |                                     | P0024 | 81H                                     | 9DH                 | VTC exhaust function diagnosis (VTC alignment check diagnosis)                       |
|               |         |                                     | P0021 | 82H                                     | 9DH                 | VTC intake function diagnosis (VTC drive failure diagnosis)                          |
|               |         |                                     | P0024 | 83H                                     | 9DH                 | VTC exhaust function diagnosis (VTC drive failure diagnosis)                         |
|               |         |                                     | P100B | 84H                                     | 10H                 | VEL slow response diagnosis  |
|               |         |                                     | P1093 | 85H                                     | 10H                 | VEL servo system diagnosis   |

A

EC

C

D

E

F

G

H

I

J

K

L

M

N

O

P

# ECM

< ECU DIAGNOSIS INFORMATION >

[VQ37VHR FOR MEXICO]

| Item             | OBD-MID | Self-diagnostic test item                  | DTC                                   | Test value and Test limit (GST display) |                     | Description  |
|------------------|---------|--|---------------------------------------|---|---------------------|--|
|                  |         |  |                                       | TID                                     | Unit and Scaling ID |  |
| EVAP SYSTEM      | 39H     | EVAP control system leak (Cap Off)         | P0455                                 | 80H                                     | 0CH                 | Difference in pressure sensor output voltage before and after pull down                |
|                  | 3BH     | EVAP control system leak (Small leak)      | P0442                                 | 80H                                     | 05H                 | Leak area index (for more than 0.04 inch)  |
|                  | 3CH     | EVAP control system leak (Very small leak) | P0456                                 | 80H                                     | 05H                 | Leak area index (for more than 0.02 inch)  |
|                  |         |  | P0456                                 | 81H                                     | FDH                 | Maximum internal pressure of EVAP system during monitoring                             |
|                  |         |  | P0456                                 | 82H                                     | FDH                 | Internal pressure of EVAP system at the end of monitoring                              |
|                  | 3DH     | Purge flow system                          | P0441                                 | 83H                                     | 0CH                 | Difference in pressure sensor output voltage before and after vent control valve close |
| O2 SENSOR HEATER | 41H     | A/F sensor 1 heater (Bank 1)               | Low Input: P0031<br>High Input: P0032 | 81H                                     | 0BH                 | Converted value of heater electric current to voltage                                  |
|                  | 42H     | Heated oxygen sensor 2 heater (Bank 1)     | Low Input: P0037<br>High Input: P0038 | 80H                                     | 0CH                 | Converted value of heater electric current to voltage                                  |
|                  | 43H     | Heated oxygen sensor 3 heater (Bank 1)     | P0043                                 | 80H                                     | 0CH                 | Converted value of heater electric current to voltage                                  |
|                  | 45H     | A/F sensor 1 heater (Bank 2)               | Low Input: P0051<br>High Input: P0052 | 81H                                     | 0BH                 | Converted value of heater electric current to voltage                                  |
|                  | 46H     | Heated oxygen sensor 2 heater (Bank 2)     | Low Input: P0057<br>High Input: P0058 | 80H                                     | 0CH                 | Converted value of heater electric current to voltage                                  |
|                  | 47H     | Heated oxygen sensor 3 heater (Bank 2)     | P0063                                 | 80H                                     | 0CH                 | Converted value of heater electric current to voltage                                  |
| SECONDARY AIR    | 71H     | Secondary air system                       | P0411                                 | 80H                                     | 01H                 | Secondary air injection system incorrect flow detected                                 |
|                  |         |  | Bank1: P0491<br>Bank2: P0492          | 81H                                     | 01H                 | Secondary air injection system insufficient flow                                       |
|                  |         |  | P2445                                 | 82H                                     | 01H                 | Secondary air injection system pump stuck off  |
|                  |         |  | P2448                                 | 83H                                     | 01H                 | Secondary air injection system high airflow  |
|                  |         |  | Bank1: P2440<br>Bank2: P2442          | 84H                                     | 01H                 | Secondary air injection system switching valve stuck open                              |
|                  |         |  | P2440                                 | 85H                                     | 01H                 | Secondary air injection system switching valve stuck open                              |
|                  |         |  | P2444                                 | 86H                                     | 01H                 | Secondary air injection system pump stuck on   |
| FUEL SYSTEM      | 81H     | Fuel injection system function (Bank 1)    | P0171 or P0172                        | 80H                                     | 2FH                 | Long term fuel trim  |
|                  |         |  | P0171 or P0172                        | 81H                                     | 24H                 | The number of lambda control clamped   |
|                  |         |  | P117A                                 | 82H                                     | 03H                 | Cylinder A/F imbalance monitoring  |
|                  | 82H     | Fuel injection system function (Bank 2)    | P0174 or P0175                        | 80H                                     | 2FH                 | Long term fuel trim  |
|                  |         |  | P0174 or P0175                        | 81H                                     | 24H                 | The number of lambda control clamped   |
|                  |         |  | P117B                                 | 82H                                     | 03H                 | Cylinder A/F imbalance monitoring  |

# ECM

< ECU DIAGNOSIS INFORMATION >

[VQ37VHR FOR MEXICO]

| Item    | OBD-MID | Self-diagnostic test item  | DTC   | Test value and Test limit (GST display) |                     | Description  |
|---------|---------|----------------------------|-------|---|---------------------|--|
|         |         |                            |       | TID                                     | Unit and Scaling ID |  |
| MISFIRE | A1H     | Multiple cylinder misfires | P0301 | 80H                                     | 24H                 | Misfiring counter at 1000 revolution of the first cylinder     |
|         |         |                            | P0302 | 81H                                     | 24H                 | Misfiring counter at 1000 revolution of the second cylinder    |
|         |         |                            | P0303 | 82H                                     | 24H                 | Misfiring counter at 1000 revolution of the third cylinder     |
|         |         |                            | P0304 | 83H                                     | 24H                 | Misfiring counter at 1000 revolution of the fourth cylinder    |
|         |         |                            | P0305 | 84H                                     | 24H                 | Misfiring counter at 1000 revolution of the fifth cylinder     |
|         |         |                            | P0306 | 85H                                     | 24H                 | Misfiring counter at 1000 revolution of the sixth cylinder     |
|         |         |                            | P0307 | 86H                                     | 24H                 | Misfiring counter at 1000 revolution of the seventh cylinder   |
|         |         |                            | P0308 | 87H                                     | 24H                 | Misfiring counter at 1000 revolution of the eighth cylinder    |
|         |         |                            | P0300 | 88H                                     | 24H                 | Misfiring counter at 1000 revolution of the multiple cylinders |
|         |         |                            | P0301 | 89H                                     | 24H                 | Misfiring counter at 200 revolution of the first cylinder      |
|         |         |                            | P0302 | 8AH                                     | 24H                 | Misfiring counter at 200 revolution of the second cylinder     |
|         |         |                            | P0303 | 8BH                                     | 24H                 | Misfiring counter at 200 revolution of the third cylinder      |
|         |         |                            | P0304 | 8CH                                     | 24H                 | Misfiring counter at 200 revolution of the fourth cylinder     |
|         |         |                            | P0305 | 8DH                                     | 24H                 | Misfiring counter at 200 revolution of the fifth cylinder      |
|         |         |                            | P0306 | 8EH                                     | 24H                 | Misfiring counter at 200 revolution of the sixth cylinder      |
|         |         |                            | P0307 | 8FH                                     | 24H                 | Misfiring counter at 200 revolution of the seventh cylinder    |
|         |         |                            | P0308 | 90H                                     | 24H                 | Misfiring counter at 200 revolution of the eighth cylinder     |
|         |         |                            | P0300 | 91H                                     | 24H                 | Misfiring counter at 1000 revolution of the single cylinder    |
|         |         |                            | P0300 | 92H                                     | 24H                 | Misfiring counter at 200 revolution of the single cylinder     |
|         |         |                            | P0300 | 93H                                     | 24H                 | Misfiring counter at 200 revolution of the multiple cylinders  |

A  
EC  
C  
D  
E  
F  
G  
H  
I  
J  
K  
L  
M  
N  
O  
P

**ECM**

< ECU DIAGNOSIS INFORMATION >

**[VQ37VHR FOR MEXICO]**

| Item    | OBD-MID | Self-diagnostic test item | DTC   | Test value and Test limit (GST display) |                     | Description  |
|---------|---------|---------------------------|-------|---|---------------------|--|
|         |         |                           |       | TID                                     | Unit and Scaling ID |  |
| MISFIRE | A2H     | No. 1 cylinder misfire    | P0301 | 0BH                                     | 24H                 | EWMA (Exponential Weighted Moving Average) misfire counts for last 10 driving cycles |
|         |         |                           | P0301 | 0CH                                     | 24H                 | Misfire counts for last/current driving cycles                                       |
|         | A3H     | No. 2 cylinder misfire    | P0302 | 0BH                                     | 24H                 | EWMA (Exponential Weighted Moving Average) misfire counts for last 10 driving cycles |
|         |         |                           | P0302 | 0CH                                     | 24H                 | Misfire counts for last/current driving cycles                                       |
|         | A4H     | No. 3 cylinder misfire    | P0303 | 0BH                                     | 24H                 | EWMA (Exponential Weighted Moving Average) misfire counts for last 10 driving cycles |
|         |         |                           | P0303 | 0CH                                     | 24H                 | Misfire counts for last/current driving cycles                                       |
|         | A5H     | No. 4 cylinder misfire    | P0304 | 0BH                                     | 24H                 | EWMA (Exponential Weighted Moving Average) misfire counts for last 10 driving cycles |
|         |         |                           | P0304 | 0CH                                     | 24H                 | Misfire counts for last/current driving cycles                                       |
|         | A6H     | No. 5 cylinder misfire    | P0305 | 0BH                                     | 24H                 | EWMA (Exponential Weighted Moving Average) misfire counts for last 10 driving cycles |
|         |         |                           | P0305 | 0CH                                     | 24H                 | Misfire counts for last/current driving cycles                                       |
|         | A7H     | No. 6 cylinder misfire    | P0306 | 0BH                                     | 24H                 | EWMA (Exponential Weighted Moving Average) misfire counts for last 10 driving cycles |
|         |         |                           | P0306 | 0CH                                     | 24H                 | Misfire counts for last/current driving cycles                                       |
|         | A8H     | No. 7 cylinder misfire    | P0307 | 0BH                                     | 24H                 | EWMA (Exponential Weighted Moving Average) misfire counts for last 10 driving cycles |
|         |         |                           | P0307 | 0CH                                     | 24H                 | Misfire counts for last/current driving cycles                                       |
|         | A9H     | No. 8 cylinder misfire    | P0308 | 0BH                                     | 24H                 | EWMA (Exponential Weighted Moving Average) misfire counts for last 10 driving cycles |
|         |         |                           | P0308 | 0CH                                     | 24H                 | Misfire counts for last/current driving cycles                                       |

# VVEL CONTROL MODULE

< ECU DIAGNOSIS INFORMATION >

[VQ37VHR FOR MEXICO]

## VVEL CONTROL MODULE

### Reference Value

INFOID:000000007729716

### TERMINAL LAYOUT

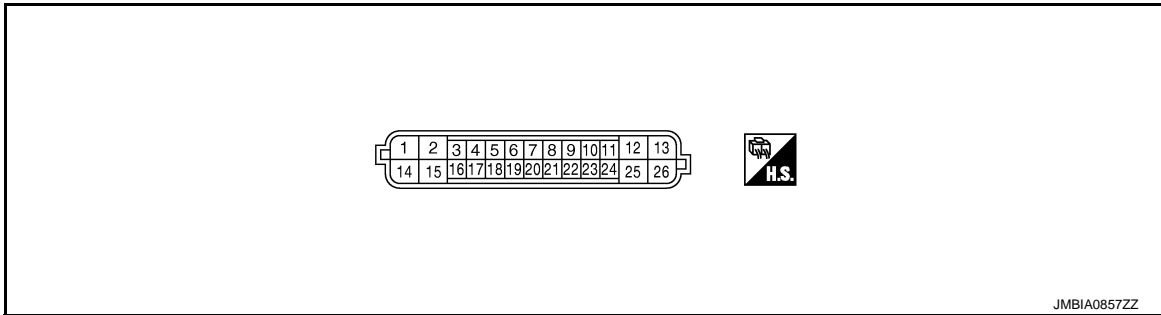

### PHYSICAL VALUES

#### NOTE:

- VVEL control module is located behind the IPDM E/R. For this inspection, remove hoodledge cover (RH).
- Specification data are reference values and are measured between each terminal and ground.
- Pulse signal is measured by CONSULT.

| Terminal No. |          | Description   |              | Condition   | Value (Approx.)                     |
|--------------|----------|---|--------------|---|-------------------------------------|
| +            | —        | Signal name   | Input/Output |   |                                     |
| 1 (W)        | 14 (B/R) | VVEL actuator motor power supply (bank 2)                     | Input        | [Ignition switch: ON]   | BATTERY VOLTAGE (11 - 14 V)         |
| 2 (L/B)      | 14 (B/R) | VVEL actuator motor (High lift) (bank 2)                      | Output       | [Engine is running]<br>• Warm-up condition<br>• Idle speed                                  | 0 - 14 V★<br><br>5V/div JMBIA0854ZZ |
|              |          |   |              | [Engine is running]<br>• Warm-up condition<br>• When revving engine up to 2,000 rpm quickly | 0 - 14 V★<br><br>5V/div JMBIA0855ZZ |
| 3 (B)        | 4 (W)    | VVEL control shaft position sensor 1 (bank 1)                 | Input        | [Engine is running]<br>• Warm-up condition<br>• Idle speed                                  | Approx.0.25 - 1.40 V                |
|              |          |   |              | [Engine is running]<br>• Warm-up condition<br>• When revving engine up to 2,000 rpm quickly | Approx.0.25 - 4.75 V                |
| 4 (W)        | —        | Sensor ground [VVEL control shaft position sensor 1 (bank 1)] | —            | —   | —                                   |

# VVEL CONTROL MODULE

< ECU DIAGNOSIS INFORMATION >

[VQ37VHR FOR MEXICO]

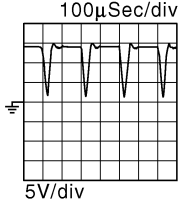
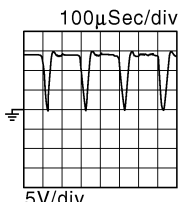
| Terminal No. |             | Description   |              | Condition   | Value (Approx.)  |
|--------------|-------------|---|--------------|---|--|
| +            | -           | Signal name   | Input/Output |   |  |
| 5<br>(W)     | 6<br>(B)    | VVEL control shaft position sensor 1 (bank 2)                       | Input        | [Engine is running]<br>• Warm-up condition<br>• Idle speed                                  | Approx.0.25 - 1.40 V   |
|              |             |   |              | [Engine is running]<br>• Warm-up condition<br>• When revving engine up to 2,000 rpm quickly | Approx.0.25 - 4.75 V   |
| 6<br>(B)     | —           | Sensor ground [VVEL control shaft position sensor 1 (bank 2)]       | —            | —   | —  |
| 7<br>(Y)     | 6<br>(B)    | Sensor power supply [VVEL control shaft position sensor 1 (bank 2)] | —            | [Ignition switch: ON]   | 5 V  |
| 8<br>(R)     | 14<br>(B/R) | Power supply for VVEL control module                                | —            | [Ignition switch: ON]   | BATTERY VOLTAGE (11 - 14 V)  |
| 9<br>(L)     | 4<br>(W)    | Sensor power supply [VVEL control shaft position sensor 1 (bank 1)] | —            | [Ignition switch: ON]   | 5 V  |
| 11<br>(GR)   | —           | CAN communication line [ECM]  | Input/Output | —   | —  |
| 12<br>(L/B)  | 14<br>(B/R) | VVEL actuator motor (High lift) (bank 1)                            | Output       | [Engine is running]<br>• Warm-up condition<br>• Idle speed                                  | 0 - 14 V★<br>  |
|              |             |   |              | [Engine is running]<br>• Warm-up condition<br>• When revving engine up to 2,000 rpm quickly | 0 - 14 V★<br> |
| 13<br>(W)    | 14<br>(B/R) | VVEL actuator motor power supply (bank 1)                           | Input        | [Ignition switch: ON]   | BATTERY VOLTAGE (11 - 14 V)  |
| 14<br>(B/R)  | —           | VVEL control module ground  | —            | [Engine is running]<br>• Idle speed   | —  |



# VVEL CONTROL MODULE

< ECU DIAGNOSIS INFORMATION >

[VQ37VHR FOR MEXICO]

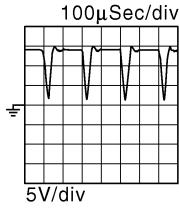
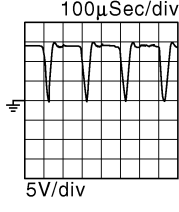
| Terminal No. |             | Description   |              | Condition   | Value (Approx.)  |
|--------------|-------------|---|--------------|---|--|
| +            | -           | Signal name   | Input/Output |   |  |
| 15<br>(L/W)  | 14<br>(B/R) | VVEL actuator motor (Low lift) (bank 2)                             | Output       | [Engine is running]<br>• Warm-up condition<br>• Idle speed                                  | 0 - 14 V★<br> |
|              |             |   |              | [Engine is running]<br>• Warm-up condition<br>• When revving engine up to 2,000 rpm quickly | 0 - 14 V★<br> |
| 16<br>(R)    | 17<br>(G)   | VVEL control shaft position sensor 2 (bank 1)                       | Input        | [Engine is running]<br>• Warm-up condition<br>• Idle speed                                  | 3.50 - 4.75 V  |
|              |             |   |              | [Engine is running]<br>• Warm-up condition<br>• When revving engine up to 2,000 rpm quickly | 0.25 - 4.75 V  |
| 17<br>(G)    | —           | Sensor ground [VVEL control shaft position sensor 2 (bank 1)]       | —            | —   | —  |
| 18<br>(G)    | 19<br>(R)   | VVEL control shaft position sensor 2 (bank 2)                       | Input        | [Engine is running]<br>• Warm-up condition<br>• Idle speed                                  | 3.50 - 4.75 V  |
|              |             |   |              | [Engine is running]<br>• Warm-up condition<br>• When revving engine up to 2,000 rpm quickly | 0.25 - 4.75 V  |
| 19<br>(R)    | —           | Sensor ground [VVEL control shaft position sensor 2 (bank 2)]       | —            | —   | —  |
| 20<br>(L)    | 19<br>(R)   | Sensor power supply [VVEL control shaft position sensor 2 (bank 2)] | —            | [Ignition switch: ON]   | 5 V  |
| 21<br>(V)    | 14<br>(B/R) | VVEL actuator motor relay abort signal                              | Input        | [Engine is running]<br>• Warm-up condition<br>• Idle speed                                  | 0 V  |
| 22<br>(Y)    | 17<br>(G)   | Sensor power supply [VVEL position sensor 2 (bank 1)]               | —            | [Ignition switch: ON]   | 5 V  |
| 23<br>(P)    | 14<br>(B/R) | VVEL control motor relay  | Output       | [Ignition switch: OFF]  | BATTERY VOLTAGE (11 - 14 V)  |
|              |             |   |              | [Ignition switch: ON]   | 0 - 1.0 V  |
| 24<br>(L)    | —           | CAN communication line  | Input/Output | —   | —  |

A

EC

C

D

E

F

G

H

I

J

K

L

M

N

O

P

# VVEL CONTROL MODULE

< ECU DIAGNOSIS INFORMATION >

[VQ37VHR FOR MEXICO]

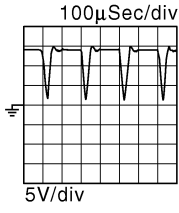
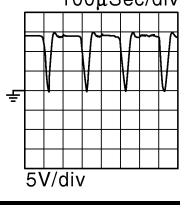
| Terminal No. |             | Description                            |              | Condition  | Value (Approx.)  |
|--------------|-------------|--|--------------|--|--|
| +            | -           | Signal name                            | Input/Output |  |  |
| 25<br>(L/W)  | 14<br>(B/R) | VVEL control motor (Low lift) (bank 1) | Output       | [Engine is running] <ul style="list-style-type: none"> <li>• Warm-up condition</li> <li>• Idle speed</li> </ul>                                  | 0 - 14 V★<br><br>5V/div JMBIA0854ZZ |
|              |             |  |              | [Engine is running] <ul style="list-style-type: none"> <li>• Warm-up condition</li> <li>• When revving engine up to 2,000 rpm quickly</li> </ul> | 0 - 14 V★<br><br>5V/div JMBIA0855ZZ |

★: Average voltage for pulse signal (Actual pulse signal can be confirmed by oscilloscope.)

# WIRING DIAGRAM

## ENGINE CONTROL SYSTEM

### Wiring Diagram

INFOID:000000007729717

A

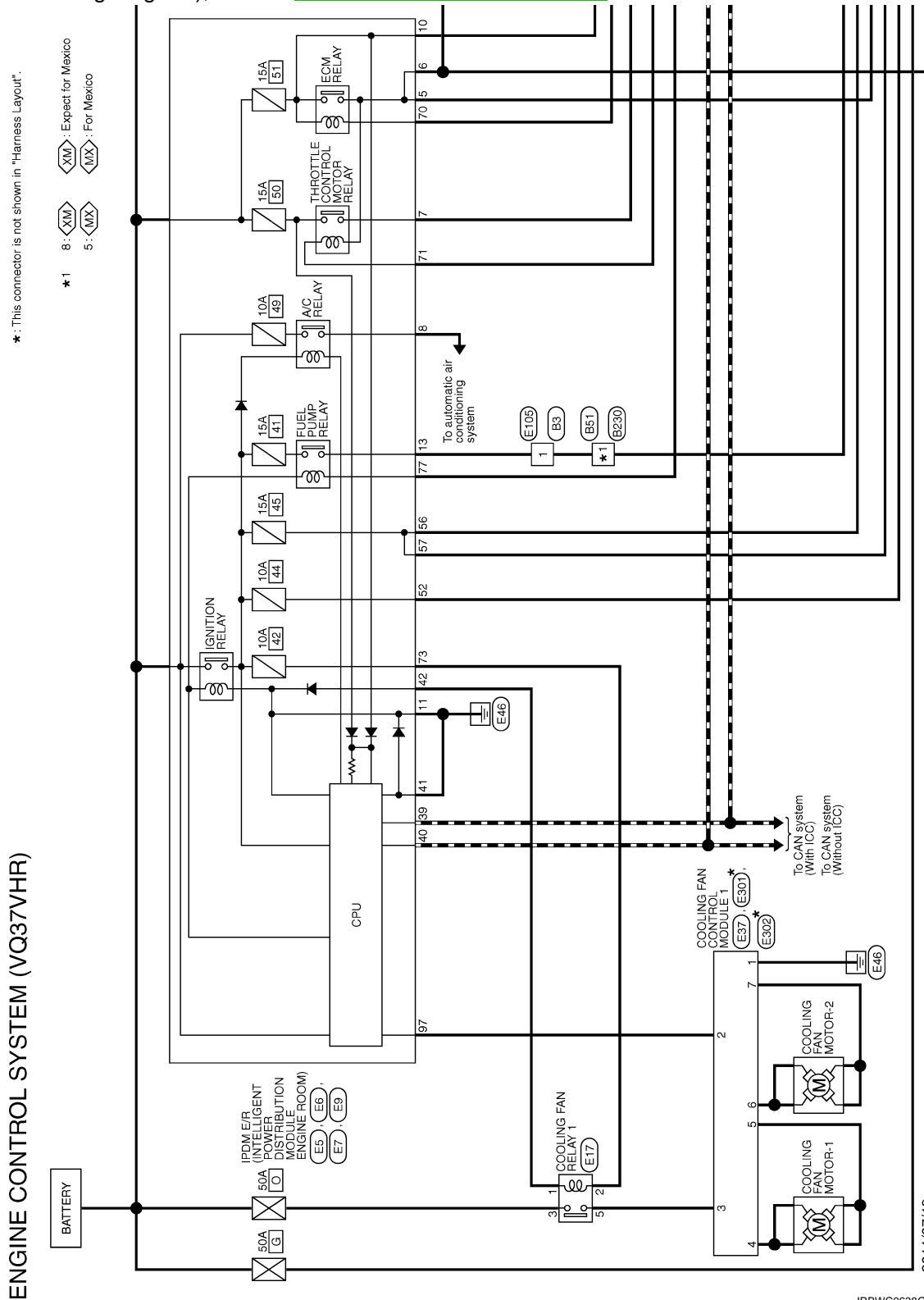

EC

For connector terminal arrangements, harness layouts, and alphabets in a  (option abbreviation; if not described in wiring diagram), refer to [GI-12. "Connector Information"](#).



ENGINE CONTROL SYSTEM (VQ37VHR)

\*: This connector is not shown in "Harness Layout".

\*1 8:  Expect for Mexico  
5:  For Mexico

C

D

E

F

G

H

I

J

K

L

M

N

O

P

# ENGINE CONTROL SYSTEM

< WIRING DIAGRAM >

[VQ37VHR FOR MEXICO]

IC : With ICC  
OI : Without ICC

\*: This connector is not shown in "Harness Layout".

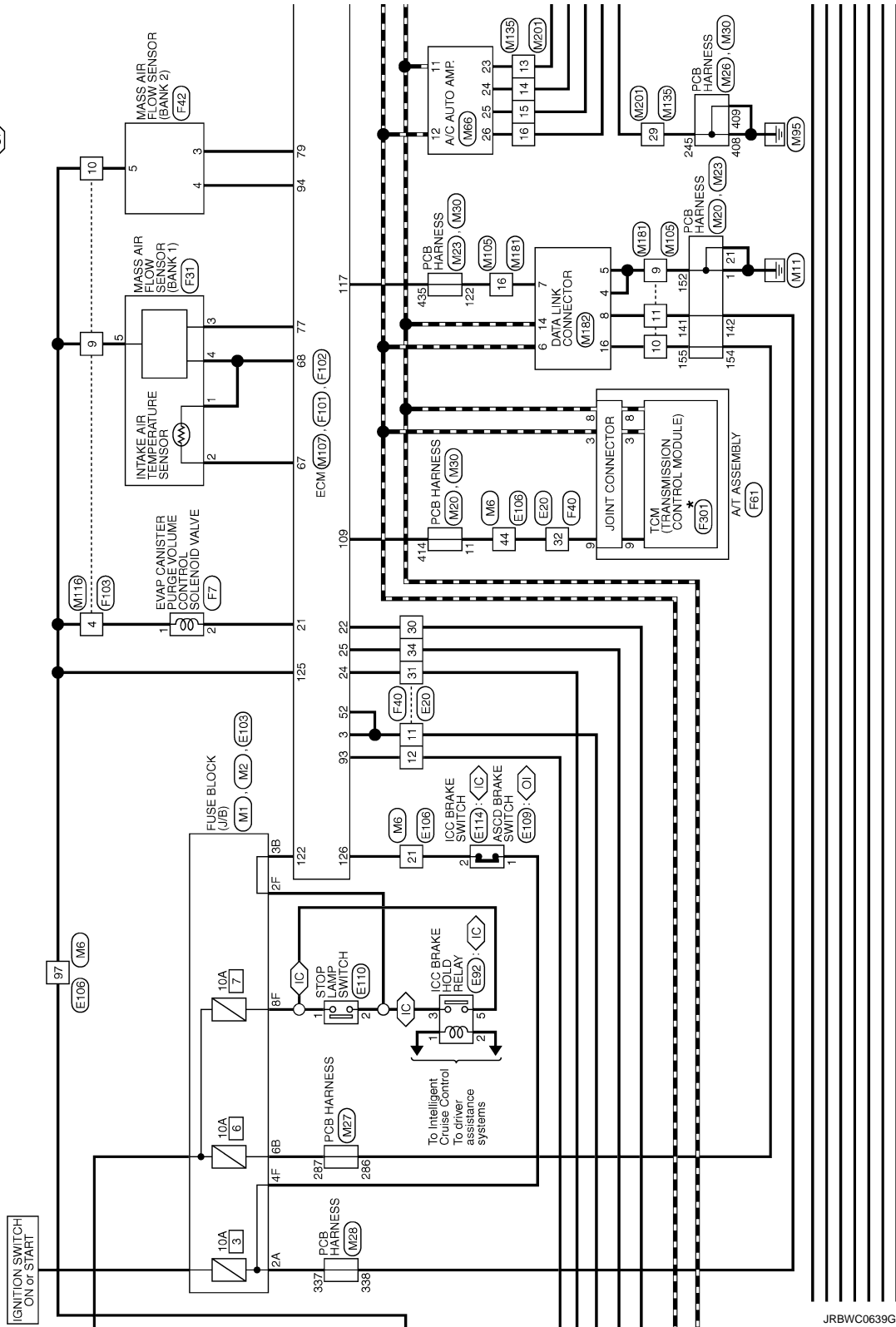

JRBWC0639GB

# ENGINE CONTROL SYSTEM

< WIRING DIAGRAM >

[VQ37VHR FOR MEXICO]

\*: This connector is not shown in "Harness Layout".

(XM): Expect for Mexico  
(MX): For Mexico  
(IC): With ICC  
(OI): Without ICC

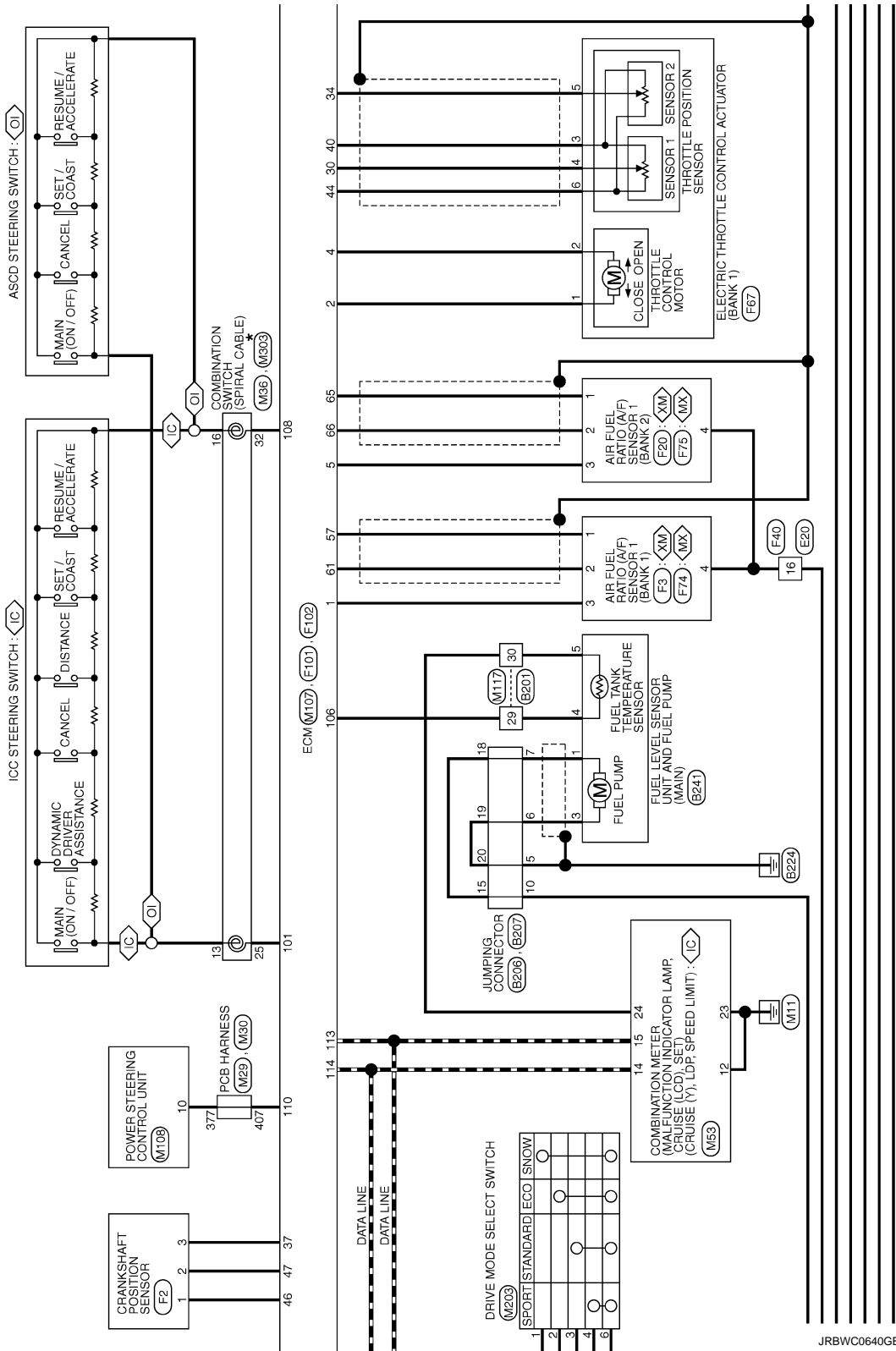

JRBWC0640GB

A  
EC  
C  
D  
E  
F  
G  
H  
I  
J  
K  
L  
M  
N  
O  
P

# ENGINE CONTROL SYSTEM

< WIRING DIAGRAM >

[VQ37VHR FOR MEXICO]

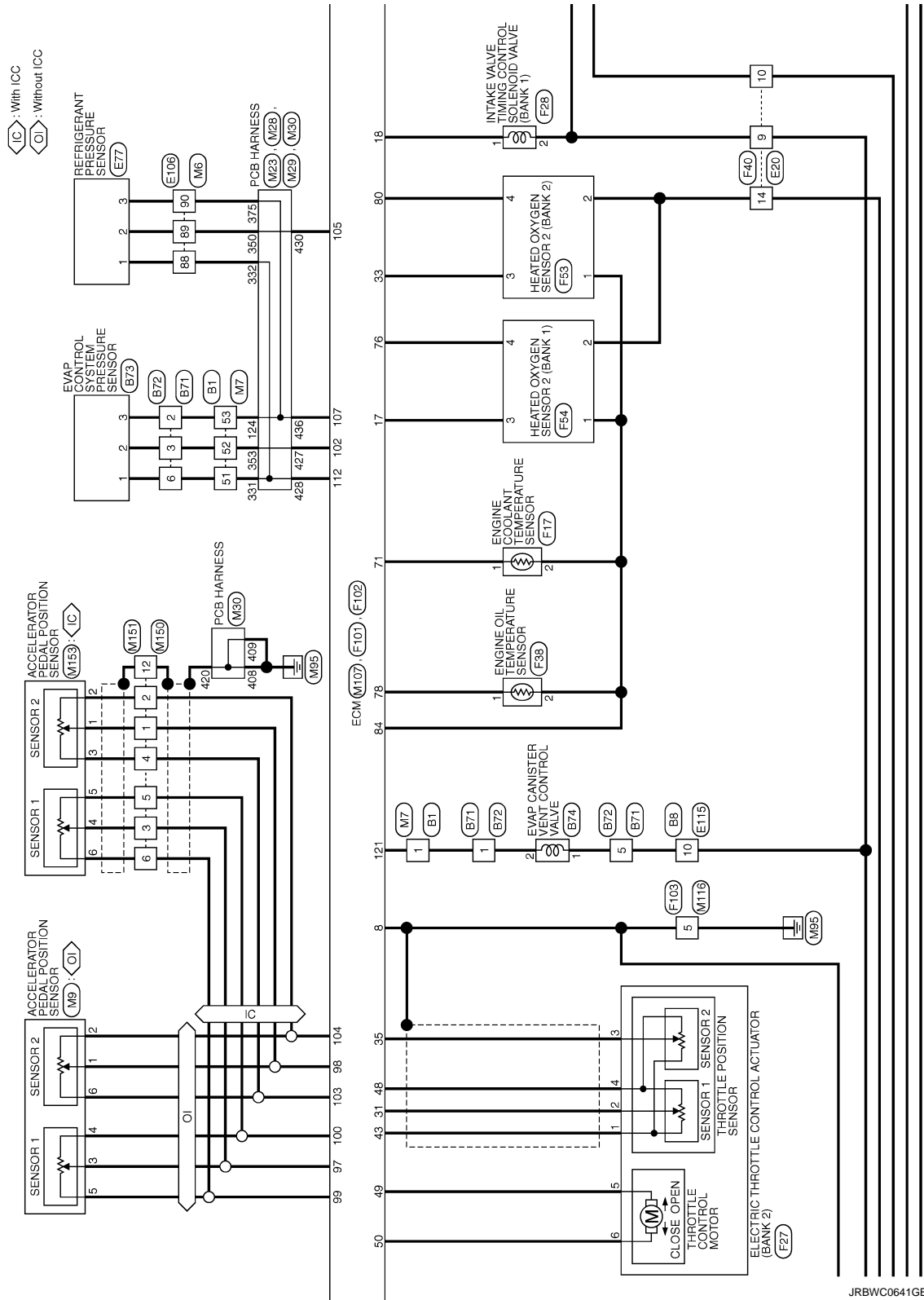

JRBWC0641GB

# ENGINE CONTROL SYSTEM

< WIRING DIAGRAM >

[VQ37VHR FOR MEXICO]

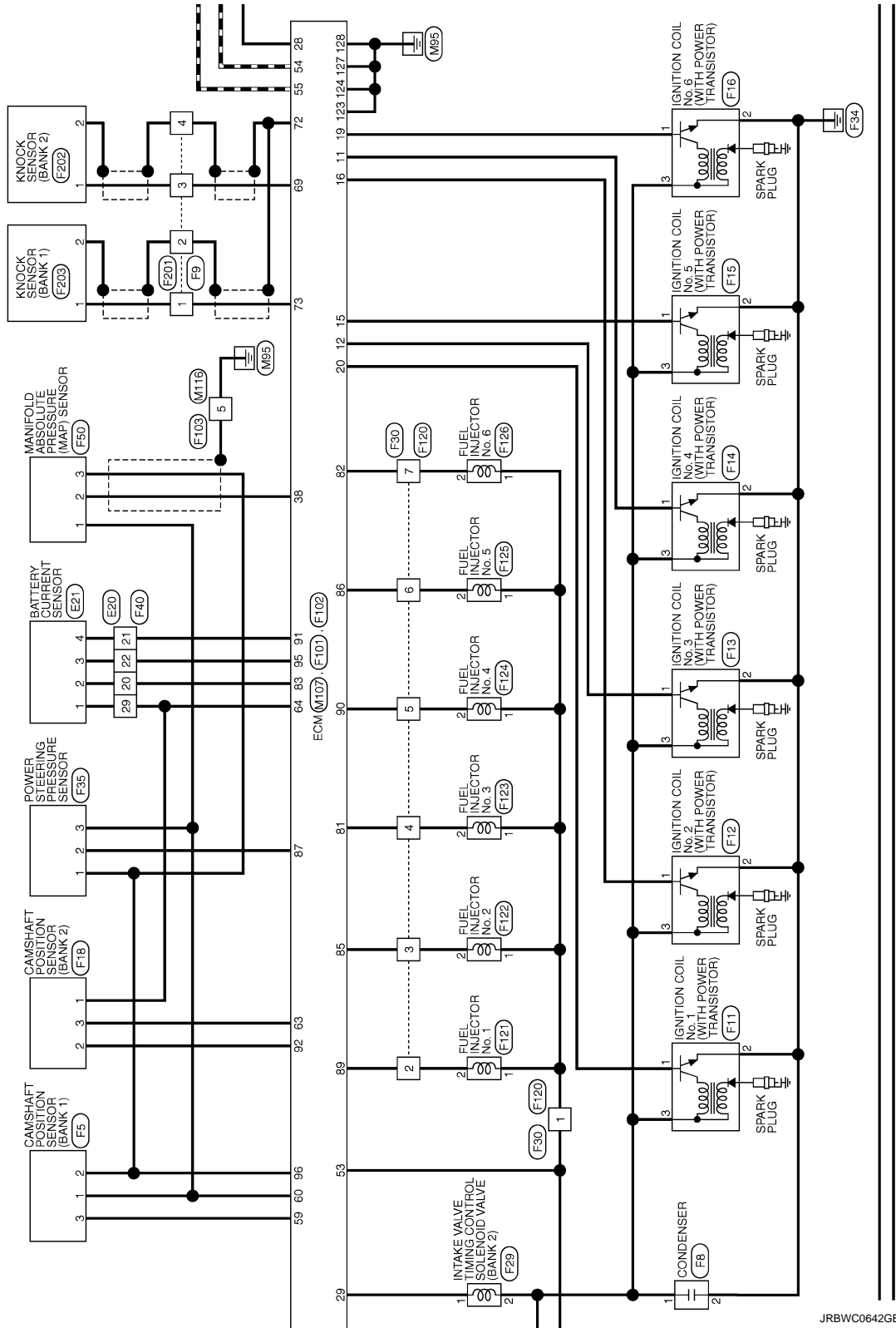

JRBWC0642GB

A  
EC  
C  
D  
E  
F  
G  
H  
I  
J  
K  
L  
M  
N  
O  
P

# ENGINE CONTROL SYSTEM

< WIRING DIAGRAM >

[VQ37VHR FOR MEXICO]

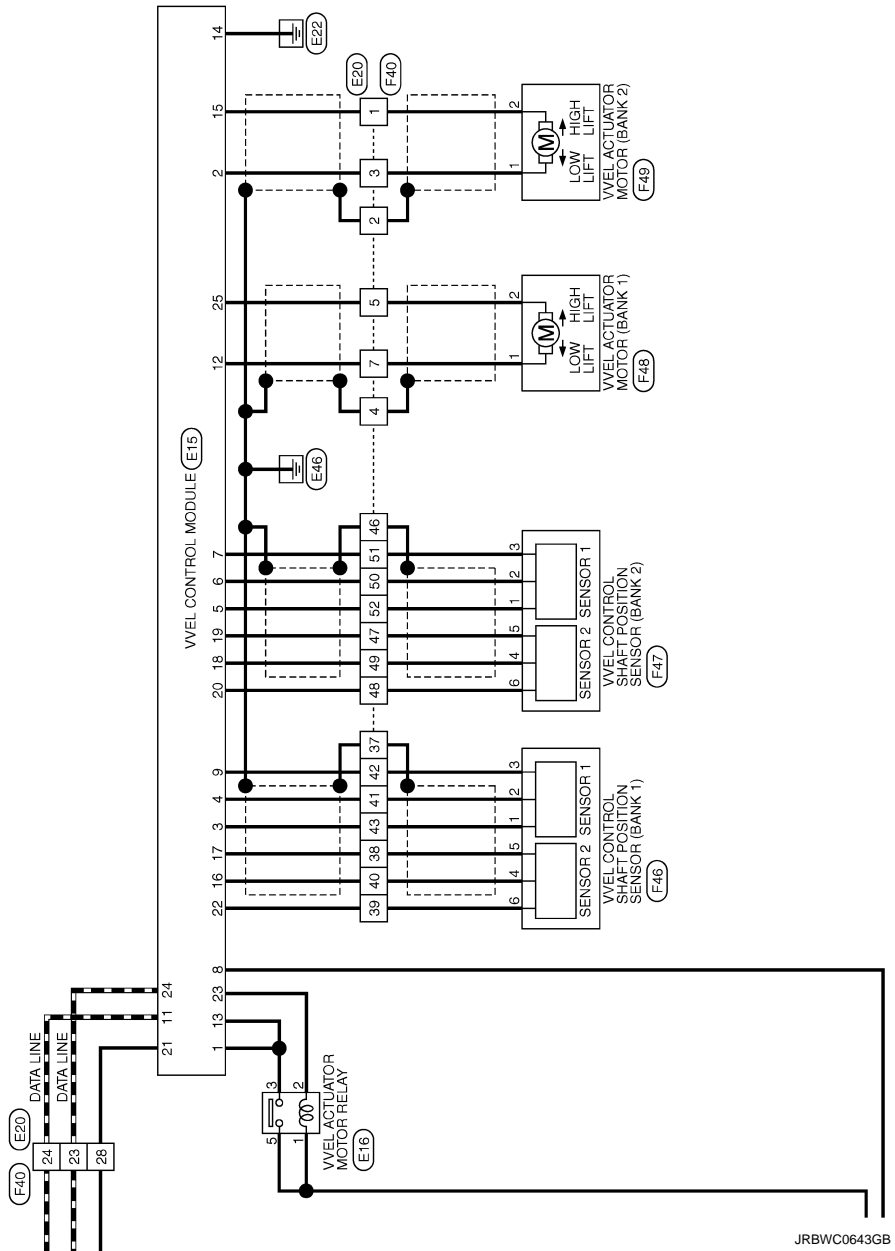



# DIAGNOSIS AND REPAIR WORKFLOW

< BASIC INSPECTION >

[VQ37VHR FOR MEXICO]

## BASIC INSPECTION

### DIAGNOSIS AND REPAIR WORKFLOW

Work Flow

INFOID:000000007793177

A

EC

#### OVERALL SEQUENCE

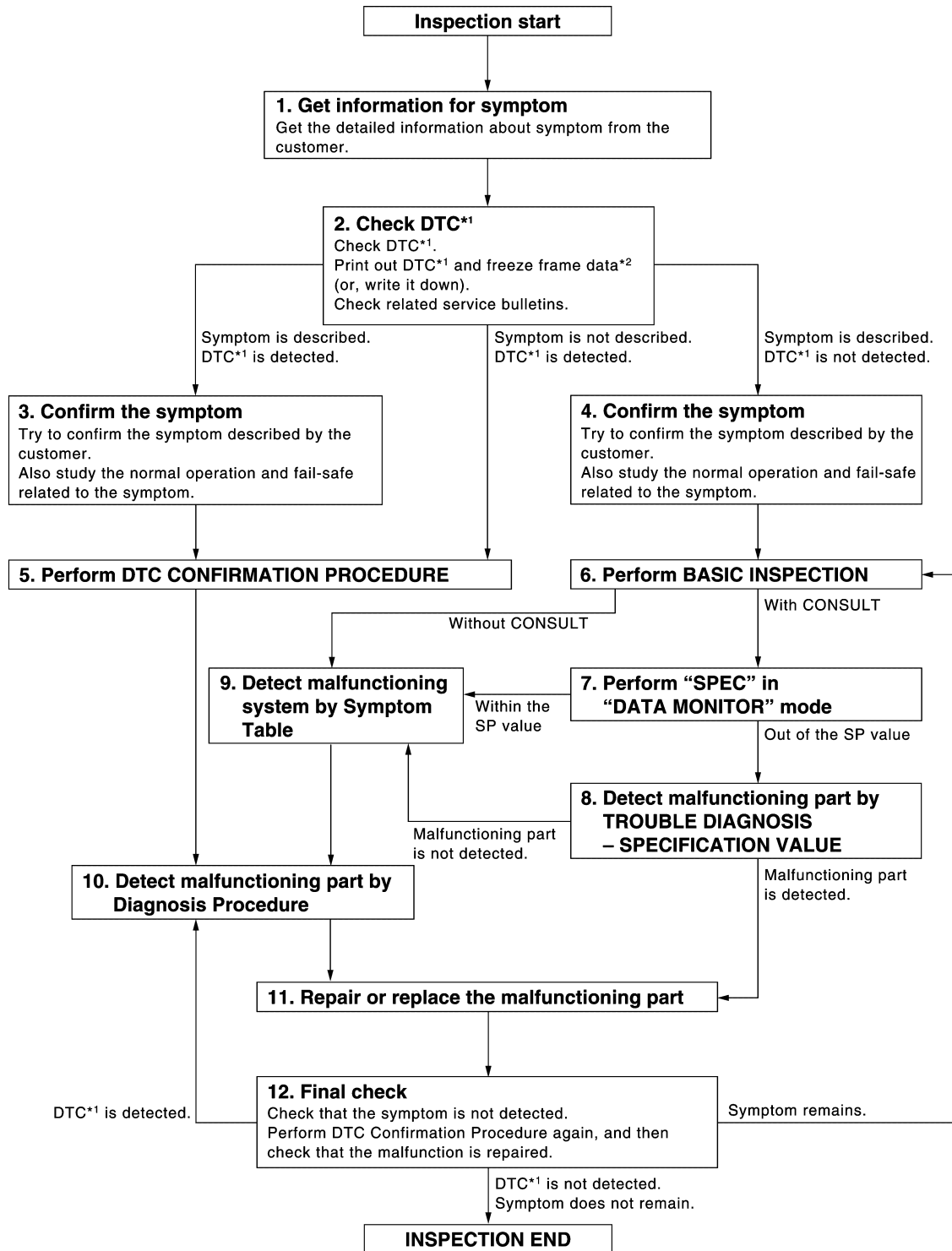

\*1: Include 1st trip DTC.

\*2: Include 1st trip freeze frame data.

JSBIA1228GB

#### DETAILED FLOW

# DIAGNOSIS AND REPAIR WORKFLOW

< BASIC INSPECTION >

[VQ37VHR FOR MEXICO]

## 1.GET INFORMATION FOR SYMPTOM

---

Get the detailed information from the customer about the symptom (the condition and the environment when the incident/malfunction occurred) using the "Diagnostic Work Sheet". (Refer to [EC-651, "Diagnostic Work Sheet"](#).)

>> GO TO 2.

## 2.CHECK DTC

---

1. Check DTC.
2. Perform the following procedure if DTC is displayed.
  - Record DTC and freeze frame data. (Print them out with CONSULT or GST.)
  - Erase DTC. (Refer to [EC-598, "On Board Diagnosis Function"](#).)
  - Study the relationship between the cause detected by DTC and the symptom described by the customer. (Symptom Matrix Chart is useful. Refer to [EC-969, "Symptom Table"](#).)
3. Check related service bulletins for information.

Are any symptoms described and is any DTCs detected?

Symptom is described, DTC is detected>>GO TO 3.

Symptom is described, DTC is not detected>>GO TO 4.

Symptom is not described, DTC is detected>>GO TO 5.

## 3.CONFIRM THE SYMPTOM

---

Try to confirm the symptom described by the customer (except MI ON).

Also study the normal operation and fail-safe related to the symptom. Refer to [EC-974, "Description"](#) and [EC-625, "Fail safe"](#).

Diagnosis Work Sheet is useful to verify the incident.

Verify relation between the symptom and the condition when the symptom is detected.

>> GO TO 5.

## 4.CONFIRM THE SYMPTOM

---

Try to confirm the symptom described by the customer.

Also study the normal operation and fail-safe related to the symptom. Refer to [EC-974, "Description"](#) and [EC-625, "Fail safe"](#).

Diagnosis Work Sheet is useful to verify the incident.

Verify relation between the symptom and the condition when the symptom is detected.

>> GO TO 6.

## 5.PERFORM DTC CONFIRMATION PROCEDURE

---

Perform DTC CONFIRMATION PROCEDURE for the displayed DTC, and then make sure that DTC is detected again.

If two or more DTCs are detected, refer to [EC-627, "DTC Inspection Priority Chart"](#) and determine trouble diagnosis order.

### NOTE:

- Freeze frame data is useful if the DTC is not detected.
- Perform Component Function Check if DTC CONFIRMATION PROCEDURE is not included on Service Manual. This simplified check procedure is an effective alternative though DTC cannot be detected during this check.
  - If the result of Component Function Check is NG, it is the same as the detection of DTC by DTC CONFIRMATION PROCEDURE.

Is DTC detected?

YES >> GO TO 10.

NO >> Check according to [GI-44, "Intermittent Incident"](#).

## 6.PERFORM BASIC INSPECTION

---

Perform [EC-663, "Work Procedure"](#).

Do you have CONSULT?

# DIAGNOSIS AND REPAIR WORKFLOW

< BASIC INSPECTION >

[VQ37VHR FOR MEXICO]

- YES >> GO TO 7.
- NO >> GO TO 9.

## 7. PERFORM SPEC IN DATA MONITOR MODE

### With CONSULT

Make sure that "MAS A/F SE-B1", "MAS A/F SE-B2", "B/FUEL SCHDL", and "A/F ALPHA-B1", "A/F ALPHA-B2" are within the SP value using CONSULT "SPEC" in "DATA MONITOR" mode. Refer to [EC-674, "Component Function Check"](#).

Is the measurement value within the SP value?

- YES >> GO TO 9.
- NO >> GO TO 8.

## 8. DETECT MALFUNCTIONING PART BY TROUBLE DIAGNOSIS - SPECIFICATION VALUE

Detect malfunctioning part according to [EC-675, "Diagnosis Procedure"](#).

Is a malfunctioning part detected?

- YES >> GO TO 11.
- NO >> GO TO 9.

## 9. DETECT MALFUNCTIONING SYSTEM BY SYMPTOM TABLE

Detect malfunctioning system according to [EC-969, "Symptom Table"](#) based on the confirmed symptom in step 4, and determine the trouble diagnosis order based on possible causes and symptoms.

>> GO TO 10.

## 10. DETECT MALFUNCTIONING PART BY DIAGNOSIS PROCEDURE

Inspect according to Diagnosis Procedure of the system.

### NOTE:

The Diagnosis Procedure in EC section described based on open circuit inspection. A short circuit inspection is also required for the circuit check in the Diagnosis Procedure. For details, refer to [GI-47, "Circuit Inspection"](#).

Is a malfunctioning part detected?

- YES >> GO TO 11.
- NO >> Monitor input data from related sensors or check voltage of related ECM terminals using CONSULT. Refer to [EC-609, "Reference Value"](#).

## 11. REPAIR OR REPLACE THE MALFUNCTIONING PART

1. Repair or replace the malfunctioning part.
2. Reconnect parts or connectors disconnected during Diagnosis Procedure again after repair and replacement.
3. Check DTC. If DTC is displayed, erase it. Refer to [EC-598, "On Board Diagnosis Function"](#) (Without CONSULT) or [EC-601, "CONSULT Function"](#) (With CONSULT).

>> GO TO 12.

## 12. FINAL CHECK

When DTC was detected in step 2, perform DTC CONFIRMATION PROCEDURE or Component Function Check again, and then make sure that the malfunction have been completely repaired.

When symptom was described from the customer, refer to confirmed symptom in step 3 or 4, and make sure that the symptom is not detected.

Is DTC detected and does symptom remain?

- YES-1 >> DTC is detected: GO TO 10.
- YES-2 >> Symptom remains: GO TO 6.
- NO >> Before returning the vehicle to the customer, make sure to always erase unnecessary DTC in ECM and TCM (Transmission Control Module). Refer to [EC-590, "Diagnosis Description"](#).

## Diagnostic Work Sheet

INFOID:000000007793178

### DESCRIPTION

# DIAGNOSIS AND REPAIR WORKFLOW

< BASIC INSPECTION >

[VQ37VHR FOR MEXICO]

There are many operating conditions that lead to the malfunction of engine components. A good grasp of such conditions can make troubleshooting faster and more accurate.

In general, each customer feels differently about symptoms. It is important to fully understand the symptoms or conditions for a customer complaint.

Utilize a diagnostic worksheet like the one on the next page in order to organize all the information for troubleshooting.

Some conditions may cause the MI to illuminate or blink, and DTC to be detected. Examples:

- Vehicle ran out of fuel, which caused the engine to misfire.
- Fuel filler cap was left off or incorrectly screwed on, allowing fuel to evaporate into the atmosphere.

### KEY POINTS

- WHAT** ..... Vehicle & engine model  
**WHEN** ..... Date, Frequencies  
**WHERE**..... Road conditions  
**HOW** ..... Operating conditions,  
Weather conditions,  
Symptoms

SEF907L

## WORKSHEET SAMPLE

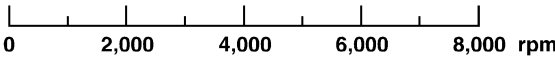
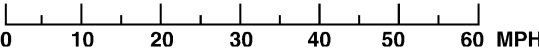
|                            |                                       |   |                 |
|----------------------------|---------------------------------------|---|-----------------|
| Customer name MR/MS        |                                       | Model & Year  | VIN             |
| Engine #                   |                                       | Trans.  | Mileage         |
| Incident Date              |                                       | Manuf. Date   | In Service Date |
| Fuel and fuel filler cap   |                                       | <input type="checkbox"/> Vehicle ran out of fuel causing misfire<br><input type="checkbox"/> Fuel filler cap was left off or incorrectly screwed on.  |                 |
| Symptoms                   | <input type="checkbox"/> Startability | <input type="checkbox"/> Impossible to start <input type="checkbox"/> No combustion <input type="checkbox"/> Partial combustion<br><input type="checkbox"/> Partial combustion affected by throttle position<br><input type="checkbox"/> Partial combustion NOT affected by throttle position<br><input type="checkbox"/> Possible but hard to start <input type="checkbox"/> Others [                          ]                                     |                 |
|                            | <input type="checkbox"/> Idling       | <input type="checkbox"/> No fast idle <input type="checkbox"/> Unstable <input type="checkbox"/> High idle <input type="checkbox"/> Low idle<br><input type="checkbox"/> Others [                          ]  |                 |
|                            | <input type="checkbox"/> Driveability | <input type="checkbox"/> Stumble <input type="checkbox"/> Surge <input type="checkbox"/> Knock <input type="checkbox"/> Lack of power<br><input type="checkbox"/> Intake backfire <input type="checkbox"/> Exhaust backfire<br><input type="checkbox"/> Others [                          ]   |                 |
|                            | <input type="checkbox"/> Engine stall | <input type="checkbox"/> At the time of start <input type="checkbox"/> While idling<br><input type="checkbox"/> While accelerating <input type="checkbox"/> While decelerating<br><input type="checkbox"/> Just after stopping <input type="checkbox"/> While loading   |                 |
| Incident occurrence        |                                       | <input type="checkbox"/> Just after delivery <input type="checkbox"/> Recently<br><input type="checkbox"/> In the morning <input type="checkbox"/> At night <input type="checkbox"/> In the daytime   |                 |
| Frequency                  |                                       | <input type="checkbox"/> All the time <input type="checkbox"/> Under certain conditions <input type="checkbox"/> Sometimes  |                 |
| Weather conditions         |                                       | <input type="checkbox"/> Not affected   |                 |
|                            | Weather                               | <input type="checkbox"/> Fine <input type="checkbox"/> Raining <input type="checkbox"/> Snowing <input type="checkbox"/> Others [                          ]  |                 |
|                            | Temperature                           | <input type="checkbox"/> Hot <input type="checkbox"/> Warm <input type="checkbox"/> Cool <input type="checkbox"/> Cold <input type="checkbox"/> Humid                          °F   |                 |
| Engine conditions          |                                       | <input type="checkbox"/> Cold <input type="checkbox"/> During warm-up <input type="checkbox"/> After warm-up<br><br>Engine speed    |                 |
| Road conditions            |                                       | <input type="checkbox"/> In town <input type="checkbox"/> In suburbs <input type="checkbox"/> Highway <input type="checkbox"/> Off road (up/down)   |                 |
| Driving conditions         |                                       | <input type="checkbox"/> Not affected<br><input type="checkbox"/> At starting <input type="checkbox"/> While idling <input type="checkbox"/> At racing<br><input type="checkbox"/> While accelerating <input type="checkbox"/> While cruising<br><input type="checkbox"/> While decelerating <input type="checkbox"/> While turning (RH/LH)<br><br>Vehicle speed  |                 |
| Malfunction indicator lamp |                                       | <input type="checkbox"/> Turned on <input type="checkbox"/> Not turned on   |                 |

MTBL0017

# ADDITIONAL SERVICE WHEN REPLACING ECM

< BASIC INSPECTION >

[VQ37VHR FOR MEXICO]

## ADDITIONAL SERVICE WHEN REPLACING ECM

### Description

INFOID:000000007729721

When replacing ECM, the following procedure must be performed.

### Work Procedure

INFOID:000000007729722

**1.**PERFORM INITIALIZATION OF IVIS (NATS) SYSTEM AND REGISTRATION OF ALL IVIS (NATS) IGNITION KEY IDS

Refer to [SEC-39. "ECM : Work Procedure"](#).

>> GO TO 2.

**2.**PERFORM VIN REGISTRATION

Refer to [EC-655. "Work Procedure"](#).

>> GO TO 3.

**3.**PERFORM ACCELERATOR PEDAL RELEASED POSITION LEARNING

Refer to [EC-656. "Work Procedure"](#).

>> GO TO 4.

**4.**PERFORM THROTTLE VALVE CLOSED POSITION LEARNING

Refer to [EC-657. "Work Procedure"](#).

>> GO TO 5.

**5.**PERFORM IDLE AIR VOLUME LEARNING

Refer to [EC-658. "Work Procedure"](#).

>> END

A

EC

C

D

E

F

G

H

I

J

K

L

M

N

O

P

## ADDITIONAL SERVICE WHEN REPLACING VVEL CONTROL MODULE

< BASIC INSPECTION >

[VQ37VHR FOR MEXICO]

---

## ADDITIONAL SERVICE WHEN REPLACING VVEL CONTROL MODULE

### Description

INFOID:000000007729723

When replacing VVEL control module, the following procedure must be performed.

### Work Procedure

INFOID:000000007729724

#### 1. PERFORM IDLE AIR VOLUME LEARNING

---

Refer to [EC-658, "Work Procedure"](#).

>> END

VIN REGISTRATION

Description

INFOID:000000007729725

VIN Registration is an operation to registering VIN in ECM. It must be performed each time ECM is replaced.

**NOTE:**

Accurate VIN which is registered in ECM may be required for Inspection & Maintenance (I/M).

Work Procedure

INFOID:000000007729726

**1.**CHECK VIN

Check the VIN of the vehicle and note it. Refer to [GI-35. "Information About Identification or Model Code"](#).

>> GO TO 2.

**2.**PERFORM VIN REGISTRATION

 **With CONSULT**

1. Turn ignition switch ON and engine stopped.
2. Select "VIN REGISTRATION" in "WORK SUPPORT" mode.
3. Follow the instruction of CONSULT display.

>> END

A  
EC  
C  
D  
E  
F  
G  
H  
I  
J  
K  
L  
M  
N  
O  
P

# ACCELERATOR PEDAL RELEASED POSITION LEARNING

< BASIC INSPECTION >

[VQ37VHR FOR MEXICO]

---

## ACCELERATOR PEDAL RELEASED POSITION LEARNING

### Description

INFOID:000000007729727

Accelerator Pedal Released Position Learning is a function of ECM to learn the fully released position of the accelerator pedal by monitoring the accelerator pedal position sensor output signal. It must be performed each time the harness connector of the accelerator pedal position sensor or ECM is disconnected.

### Work Procedure

INFOID:000000007729728

#### 1. START

---

1. Make sure that accelerator pedal is fully released.
2. Turn ignition switch ON and wait at least 2 seconds.
3. Turn ignition switch OFF and wait at least 10 seconds.
4. Turn ignition switch ON and wait at least 2 seconds.
5. Turn ignition switch OFF and wait at least 10 seconds.

>> END



# THROTTLE VALVE CLOSED POSITION LEARNING

< BASIC INSPECTION >

[VQ37VHR FOR MEXICO]

## THROTTLE VALVE CLOSED POSITION LEARNING

### Description

INFOID:000000007729729

Throttle Valve Closed Position Learning is a function of ECM to learn the fully closed position of the throttle valve by monitoring the throttle position sensor output signal. It must be performed each time harness connector of electric throttle control actuator or ECM is disconnected or electric throttle control actuator is cleaned.

### Work Procedure

INFOID:000000007729730

#### 1. START

##### With CONSULT

1. Turn ignition switch ON.
2. Select "CLSD THL POS LEARN" in "WORK SUPPORT" mode.
3. Follow the instructions on the CONSULT display.
4. Turn ignition switch OFF and wait at least 10 seconds.
5. Check that throttle valve moves during the above 10 seconds by confirming the operating sound.

##### Without CONSULT

1. Start the engine.  
**NOTE:**  
Coolant temperature is less than 25°C (77°F) before engine starts.
2. Warm up the engine until engine coolant temperature reaches 65°C (149°F).
3. Turn ignition switch OFF and wait at least 10 seconds.
4. Check that throttle valve moves during the above 10 seconds by confirming the operating sound.

>> END

A  
EC  
C  
D  
E  
F  
G  
H  
I  
J  
K  
L  
M  
N  
O  
P

## IDLE AIR VOLUME LEARNING

### Description

INFOID:00000000729731

Idle Air Volume Learning is a function of ECM to learn the idle air volume that keeps engine idle speed within the specific range. It must be performed under the following conditions:

- Each time electric throttle control actuator or ECM is replaced.
- Each time VVEL actuator sub assembly or VVEL control module is replaced.
- Idle speed or ignition timing is out of specification.

### Work Procedure

INFOID:00000000729732

#### 1. PRECONDITIONING

Make sure that all of the following conditions are satisfied.

Learning will be cancelled if any of the following conditions are missed for even a moment.

- Battery voltage: More than 12.9 V (At idle)
- Engine coolant temperature: 70 - 105°C (158 - 221°F)
- Selector lever: P or N
- Electric load switch: OFF  
(Air conditioner, headlamp, rear window defogger)
- **On vehicles equipped with daytime light systems, if the parking brake is applied before the engine is started the headlamp will not be illuminated.**
- Steering wheel: Neutral (Straight-ahead position)
- Vehicle speed: Stopped
- Transmission: Warmed-up
- With CONSULT: Drive vehicle until "ATF TEMP SE 1" in "DATA MONITOR" mode of "A/T" system indicates less than 0.9V.
- Without CONSULT: Drive vehicle for 10 minutes.

Do you have CONSULT?

- YES >> GO TO 2.
- NO >> GO TO 3.

#### 2. PERFORM IDLE AIR VOLUME LEARNING

##### With CONSULT

1. Perform Accelerator Pedal Released Position Learning. Refer to [EC-656, "Work Procedure"](#).
2. Perform Throttle Valve Closed Position Learning. [EC-657, "Work Procedure"](#).
3. Start engine and warm it up to normal operating temperature.
4. Select "IDLE AIR VOL LEARN" in "WORK SUPPORT" mode.
5. Touch "START" and wait 20 seconds.

Is "CMPLT" displayed on CONSULT screen?

- YES >> GO TO 4.
- NO >> GO TO 5.

#### 3. PERFORM IDLE AIR VOLUME LEARNING

##### Without CONSULT

**NOTE:**

- **It is better to count the time accurately with a clock.**
  - **It is impossible to switch the diagnostic mode when an accelerator pedal position sensor circuit has a malfunction.**
1. Perform Accelerator Pedal Released Position Learning. Refer to [EC-656, "Work Procedure"](#).
  2. Perform Throttle Valve Closed Position Learning. [EC-657, "Work Procedure"](#).
  3. Start engine and warm it up to normal operating temperature.
  4. Turn ignition switch OFF and wait at least 10 seconds.
  5. Confirm that accelerator pedal is fully released, turn ignition switch ON and wait 3 seconds.
  6. Repeat the following procedure quickly five times within 5 seconds.
    - Fully depress the accelerator pedal.
    - Fully release the accelerator pedal.
  7. Wait 7 seconds, fully depress the accelerator pedal for approx. 20 seconds until the MIL stops blinking and illuminates.

# IDLE AIR VOLUME LEARNING

[VQ37VHR FOR MEXICO]

< BASIC INSPECTION >

8. Fully release the accelerator pedal within 3 seconds after the MIL illuminates.
9. Start engine and let it idle.
10. Wait 20 seconds.

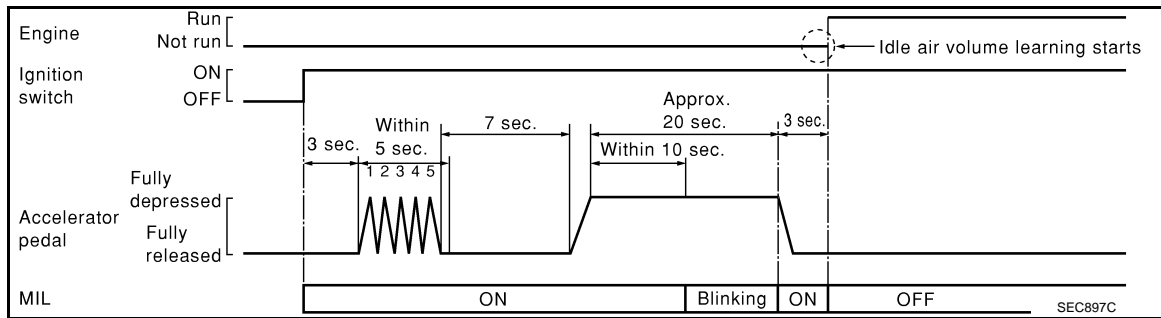

>> GO TO 4.

## 4. CHECK IDLE SPEED AND IGNITION TIMING

1. Start engine and warm it up to normal operating temperature.
2. Let it idle for 20 seconds.
3. Rev up the engine two or three times and make sure that idle speed and ignition timing are within the specifications. Refer to [EC-982. "Idle Speed"](#) and [EC-982. "Ignition Timing"](#).

Is the inspection result normal?

- YES >> INSPECTION END
- NO >> GO TO 5.

## 5. DETECT MALFUNCTIONING PART-I

Check the following

- Check that throttle valve is fully closed.
- Check PCV valve operation.
- Check that downstream of throttle valve is free from air leakage.

Is the inspection result normal?

- YES >> GO TO 6.
- NO >> Repair or replace malfunctioning part.

## 6. DETECT MALFUNCTIONING PART-II

Engine component parts and their installation condition are questionable. Check and eliminate the cause of the incident.

It is useful to perform "TROUBLE DIAGNOSIS - SPECIFICATION VALUE". Refer to [EC-674. "Description"](#).

If any of the following conditions occur after the engine has started, eliminate the cause of the incident and perform Idle Air Volume Learning again:

- Engine stalls.
- Erroneous idle.

>> INSPECTION END

# VVEL CONTROL SHAFT POSITION SENSOR ADJUSTMENT

< BASIC INSPECTION >

[VQ37VHR FOR MEXICO]

## VVEL CONTROL SHAFT POSITION SENSOR ADJUSTMENT

### Description

INFOID:000000007729733

VVEL control shaft position sensor adjustment is an operation to adjust the initial position angle that is the basis for the VVEL control shaft position sensor.

It must be performed each time VVEL actuator sub assembly is replaced.

#### CAUTION:

- It must be performed only on the replaced bank side.
- It must not be performed except when VVEL actuator sub assembly is replaced. If by any chance the adjustment is performed, replace VVEL actuator sub assembly.

### Work Procedure

INFOID:000000007729734

#### 1. START

Do you have CONSULT?

Do you have CONSULT?

YES >> GO TO 2.

NO >> GO TO 3.

#### 2. PERFORM VVEL CONTROL SHAFT POSITION SENSOR ADJUSTMENT

##### With CONSULT

1. Turn ignition switch ON.
2. Select "VVEL POS SEN ADJ PREP" in "WORK SUPPORT" mode with CONSULT.
3. Touch "Start" and wait a few seconds.
4. Make sure the "CMPLT" is displayed on CONSULT screen.
5. Select "VVEL POSITION SEN- B1" or "VVEL POSITION SEN- B2" in "DATA MONITOR" mode with CONSULT.
6. Loosen the VVEL control shaft position sensor mounting bolt (1).
7. Turn the VVEL control shaft position sensor (2) right and left while monitoring the output voltage of "VVEL POSITION SEN- B1" or "VVEL POSITION SEN- B2" and adjust the output voltage to be within the standard value.

**Voltage : 500 ± 48 mV**

8. Tighten the VVEL control shaft position sensor mounting bolt.

**Torque : 7.0 N•m (0.71 kg-m, 62 in-lb)**

9. Reconfirm that the output voltage of "VVEL POSITION SEN- B1" or "VVEL POSITION SEN- B2" is within the standard value.

**Voltage : 500 ± 48 mV**

#### NOTE:

If it varies from the standard value after the bolt is tightened, perform steps 6 to 8 again.

10. Turn ignition switch OFF and wait at least 10 seconds.
11. Start engine and warm it up to normal operating temperature.
12. Turn ignition switch OFF and wait at least 10 seconds.
13. Perform idle air volume learning. Refer to [EC-658, "Work Procedure"](#).

>> INSPECTION END

#### 3. PERFORM VVEL CONTROL SHAFT POSITION SENSOR ADJUSTMENT

##### Without CONSULT

1. Disconnect VVEL control shaft position sensor harness connector.
2. Remove VVEL actuator motor relay.
3. Turn ignition switch ON, wait at least 5 seconds and then turn OFF.
4. Reconnect all harness connectors disconnected.

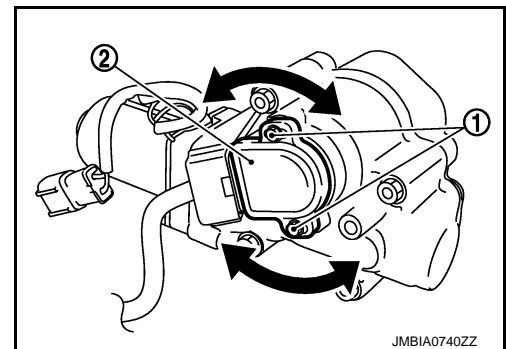

# VVEL CONTROL SHAFT POSITION SENSOR ADJUSTMENT

< BASIC INSPECTION >

[VQ37VHR FOR MEXICO]

5. Install VVEL actuator motor relay.
6. Turn ignition switch ON and wait at least 5 seconds.
7. Loosen the VVEL control shaft position sensor mounting bolt (1).
8. Turn the VVEL control shaft position sensor (2) right and left while monitoring the output voltage between the VVEL control module terminals with a tester and adjust the output voltage to be within the standard value.

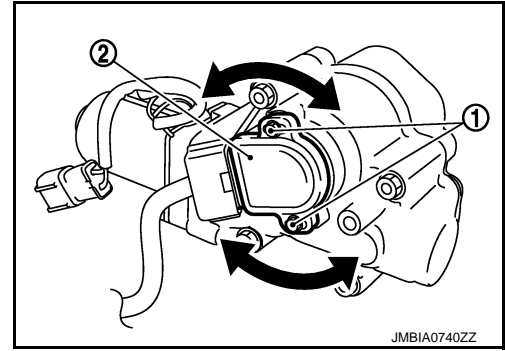

| VVEL control module |           |          |          | Voltage     |
|---------------------|-----------|----------|----------|-------------|
| Bank                | Connector | +        | -        |             |
|                     |           | Terminal | Terminal |             |
| 1                   | E15       | 3        | 4        | 500 ± 48 mV |
| 2                   |           | 5        | 6        |             |

9. Tighten the VVEL control shaft position sensor mounting bolt.



**: 7.0 N•m (0.71 kg-m, 62 in-lb)**

10. Reconfirm that the output voltage of VVEL control shaft position sensor is within the standard value.

| VVEL control module |           |          |          | Voltage     |
|---------------------|-----------|----------|----------|-------------|
| Bank                | Connector | +        | -        |             |
|                     |           | Terminal | Terminal |             |
| 1                   | E15       | 3        | 4        | 500 ± 48 mV |
| 2                   |           | 5        | 6        |             |

**NOTE:**

If it varies from the standard value after the bolt is tightened, perform steps 7 to 9 again.

11. Turn ignition switch OFF and wait at least 10 seconds.
12. Start engine and warm it up to normal operating temperature.
13. Turn ignition switch OFF and wait at least 10 seconds.
14. Perform idle air volume learning. Refer to [EC-658, "Work Procedure"](#).

>> INSPECTION END

# MIXTURE RATIO SELF-LEARNING VALUE CLEAR

< BASIC INSPECTION >

[VQ37VHR FOR MEXICO]

---

## MIXTURE RATIO SELF-LEARNING VALUE CLEAR

### Description

INFOID:000000007729735

This describes how to erase the mixture ratio self-learning value. For the actual procedure, follow the instructions in "Diagnosis Procedure".

### Work Procedure

INFOID:000000007729736

#### 1. START

---

##### With CONSULT

1. Start engine and warm it up to normal operating temperature.
2. Select "SELF-LEARNING CONT" in "WORK SUPPORT" mode with CONSULT.
3. Clear mixture ratio self-learning value by touching "CLEAR".

##### With GST

1. Start engine and warm it up to normal operating temperature.
2. Turn ignition switch OFF.
3. Disconnect mass air flow sensor (bank 1) harness connector.
4. Restart engine and let it idle for at least 5 seconds.
5. Stop engine and reconnect mass air flow sensor (bank 1) harness connector.
6. Select Service \$03 with GST. Make sure DTC P0102 is detected.
7. Select Service \$04 with GST to erase the DTC P0102.

>> END

**BASIC INSPECTION**

**Work Procedure**

INFOID:00000000729737

**1.INSPECTION START**

1. Check service records for any recent repairs that may indicate a related malfunction, or a current need for scheduled maintenance.
2. Open engine hood and check the following:
  - Harness connectors for improper connections
  - Wiring harness for improper connections, pinches and cut
  - Vacuum hoses for splits, kinks and improper connections
  - Hoses and ducts for leaks
  - Air cleaner clogging
  - Gasket
3. Confirm that electrical or mechanical loads are not applied.
  - Headlamp switch is OFF.
  - Air conditioner switch is OFF.
  - Rear window defogger switch is OFF.
  - Steering wheel is in the straight-ahead position, etc.
4. Start engine and warm it up until engine coolant temperature indicator points the middle of gauge. Ensure engine stays below 1,000 rpm.

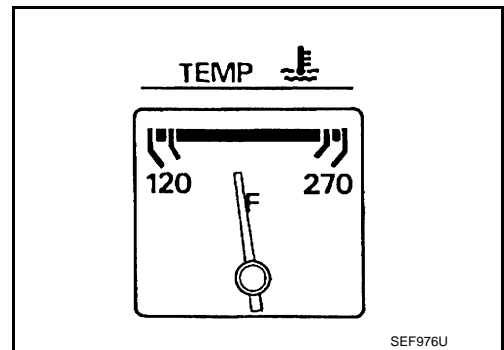
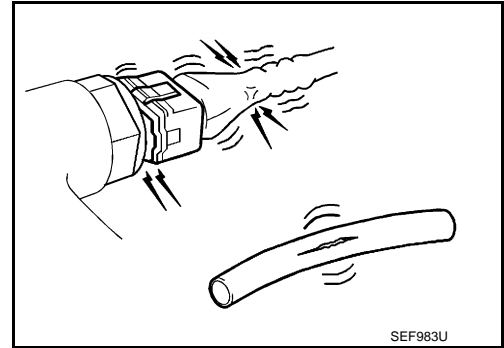

5. Run engine at about 2,000 rpm for about 2 minutes under no load.
6. Make sure that no DTC is displayed with CONSULT or GST.

Are any DTCs detected?

- YES >> GO TO 2.
- NO >> GO TO 3.

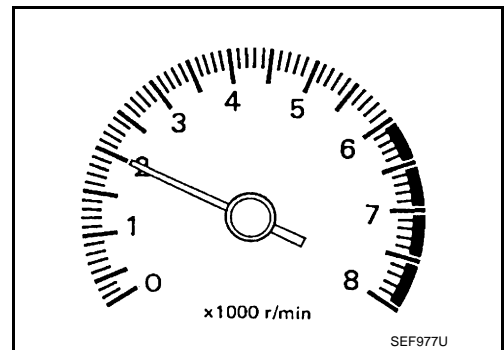

**2.REPAIR OR REPLACE**

Repair or replace components as necessary according to corresponding Diagnosis Procedure.

>> GO TO 3

**3.CHECK IDLE SPEED**

1. Run engine at about 2,000 rpm for about 2 minutes under no load.

A  
EC  
C  
D  
E  
F  
G  
H  
I  
J  
K  
L  
M  
N  
O  
P

# BASIC INSPECTION

[VQ37VHR FOR MEXICO]

## < BASIC INSPECTION >

- Rev engine (2,000 to 3,000 rpm) two or three times under no load, then run engine at idle speed for about 1 minute.
- Check idle speed.  
For procedure, refer to [EC-975, "Inspection"](#).  
For specification, refer to [EC-982, "Idle Speed"](#).

Is the inspection result normal?

- YES >> GO TO 10.  
NO >> GO TO 4.

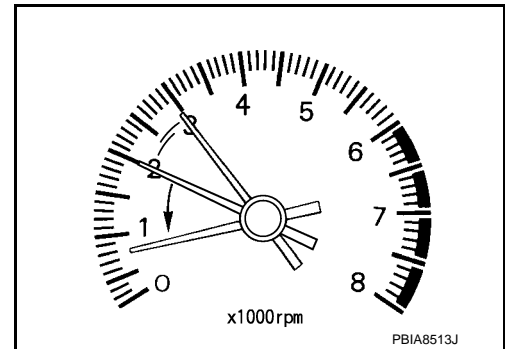

## 4.PERFORM ACCELERATOR PEDAL RELEASED POSITION LEARNING

- Stop engine.
- Perform [EC-656, "Work Procedure"](#).

>> GO TO 5.

## 5.PERFORM THROTTLE VALVE CLOSED POSITION LEARNING

Perform [EC-657, "Work Procedure"](#).

>> GO TO 6.

## 6.PERFORM IDLE AIR VOLUME LEARNING

Perform [EC-658, "Work Procedure"](#).

Is Idle Air Volume Learning carried out successfully?

- YES >> GO TO 7.  
NO >> Follow the instruction of Idle Air Volume Learning. Then GO TO 4.

## 7.CHECK IDLE SPEED AGAIN

- Start engine and warm it up to normal operating temperature.
- Check idle speed.  
For procedure, refer to [EC-975, "Inspection"](#).  
For specification, refer to [EC-982, "Idle Speed"](#).

Is the inspection result normal?

- YES >> GO TO 10.  
NO >> GO TO 8.

## 8.DETECT MALFUNCTIONING PART

Check the Following.

- Check camshaft position sensor (PHASE) and circuit. Refer to [EC-786, "Component Inspection"](#).
- Check crankshaft position sensor (POS) and circuit. Refer to [EC-781, "Component Inspection"](#).

Is the inspection result normal?

- YES >> GO TO 9.  
NO >> Repair or replace. Then GO TO 4.

## 9.CHECK ECM FUNCTION

- Substitute with a non-malfunctioning ECM to check ECM function. (ECM may be the cause of the incident, although this is rare.)
- Perform initialization of IVIS (NATS) system and registration of all IVIS (NATS) ignition key IDs. Refer to [EC-653, "Work Procedure"](#).

>> GO TO 4.

## 10.CHECK IGNITION TIMING

- Run engine at idle.



# BASIC INSPECTION

[VQ37VHR FOR MEXICO]

## < BASIC INSPECTION >

2. Check ignition timing with a timing light.

A :Timing indicator

For procedure, refer to [EC-976, "Inspection"](#).

For specification, refer to [EC-982, "Ignition Timing"](#).

Is the inspection result normal?

YES >> GO TO 19.

NO >> GO TO 11.

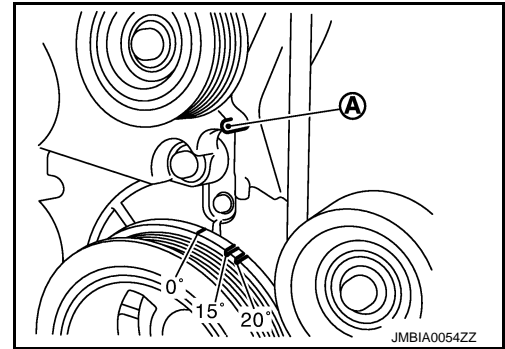

## 11.PERFORM ACCELERATOR PEDAL RELEASED POSITION LEARNING

1. Stop engine.
2. Perform [EC-656, "Work Procedure"](#).

>> GO TO 12.

## 12.PERFORM THROTTLE VALVE CLOSED POSITION LEARNING

Perform [EC-657, "Work Procedure"](#).

>> GO TO 13.

## 13.PERFORM IDLE AIR VOLUME LEARNING

Perform [EC-658, "Work Procedure"](#).

Is Idle Air Volume Learning carried out successfully?

YES >> GO TO 14.

NO >> Follow the instruction of Idle Air Volume Learning. Then GO TO 4.

## 14.CHECK IDLE SPEED AGAIN

1. Start engine and warm it up to normal operating temperature.
2. Check idle speed.

For procedure, refer to [EC-975, "Inspection"](#).

For specification, refer to [EC-982, "Idle Speed"](#).

Is the inspection result normal?

YES >> GO TO 15.

NO >> GO TO 17.

## 15.CHECK IGNITION TIMING AGAIN

1. Run engine at idle.
2. Check ignition timing with a timing light.

A :Timing indicator

For procedure, refer to [EC-976, "Inspection"](#).

For specification, refer to [EC-982, "Ignition Timing"](#).

Is the inspection result normal?

YES >> GO TO 19.

NO >> GO TO 16.

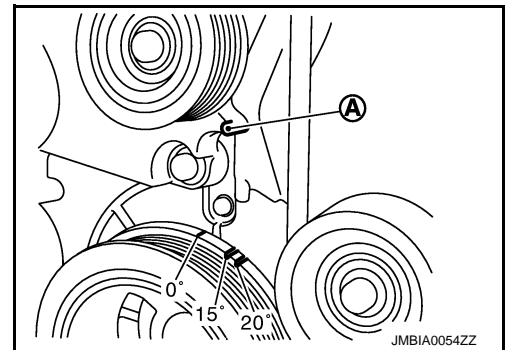

## 16.CHECK TIMING CHAIN INSTALLATION

Check timing chain installation. Refer to [EM-53, "Removal and Installation"](#).

Is the inspection result normal?

YES >> GO TO 17.

NO >> Repair the timing chain installation. Then GO TO 4.

## BASIC INSPECTION

< BASIC INSPECTION >

[VQ37VHR FOR MEXICO]

---

### 17. DETECT MALFUNCTIONING PART

---

Check the following.

- Check camshaft position sensor (PHASE) and circuit. Refer to [EC-786, "Component Inspection"](#).
- Check crankshaft position sensor (POS) and circuit. Refer to [EC-781, "Component Inspection"](#).

Is the inspection result normal?

YES >> GO TO 18.

NO >> Repair or replace. Then GO TO 4.

### 18. CHECK ECM FUNCTION

---

1. Substitute with a non-malfunctioning ECM to check ECM function. (ECM may be the cause of the incident, although this is rare.)
2. Perform initialization of IVIS (NATS) system and registration of all IVIS (NATS) ignition key IDs. Refer to [EC-653, "Work Procedure"](#).

>> GO TO 4.

### 19. INSPECTION END

---

If ECM is replaced during this BASIC INSPECTION procedure, go to [EC-653, "Work Procedure"](#).

>> INSPECTION END

## FUEL PRESSURE CHECK

### Work Procedure

INFOID:000000007729738

### FUEL PRESSURE RELEASE

#### 1. FUEL PRESSURE RELEASE

##### ☐ With CONSULT

1. Turn ignition switch ON.
2. Select ENGINE using CONSULT.
3. Perform "FUEL PRESSURE RELEASE" in "WORK SUPPORT" mode.
4. Start engine.
5. After engine stalls, crank it two or three times to release all fuel pressure.
6. Turn ignition switch OFF.

##### ☒ Without CONSULT

1. Remove fuel pump fuse (1) located in IPDM E/R (2).
2. Start engine.
3. After engine stalls, crank it two or three times to release all fuel pressure.
4. Turn ignition switch OFF.
5. Reinstall fuel pump fuse after servicing fuel system.

>> INSPECTION END

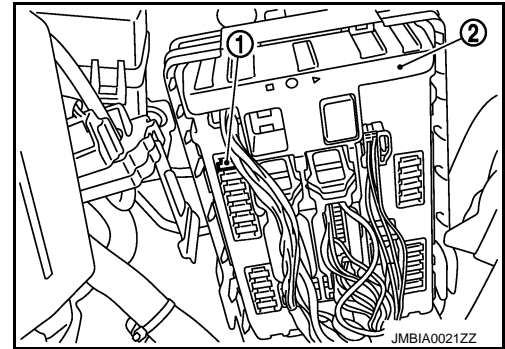

### FUEL PRESSURE CHECK

#### 1. FUEL PRESSURE CHECK

1. Release fuel pressure to zero.
2. Install the inline fuel quick disconnected fitting (A) between fuel damper (1) and injector tube.

##### **CAUTION:**

**Before disconnecting fuel line, release fuel pressure from fuel line to eliminate danger.**

##### **NOTE:**

- Prepare pans or saucers under the disconnected fuel line because the fuel may spill out. The fuel pressure cannot be completely released because Y51 models do not have fuel return system.
- Use Fuel Pressure Gauge Kit (J-44321) to check fuel pressure.

3. Connect pressure gauge (B) to fuel pressure check adapter.
4. Turn ignition switch ON and check for fuel leakage.
5. Start engine and check for fuel leakage.
6. Read the indication of fuel pressure gauge.

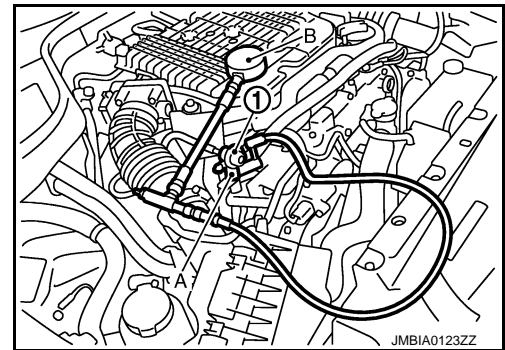

**At idling : Approximately 350 kPa (3.5 bar, 3.57 kg/cm<sup>2</sup>, 51 psi)**

Is the inspection result normal?

- YES >> INSPECTION END  
 NO >> GO TO 2.

#### 2. CHECK FUEL HOSE AND FUEL TUBE

If result is unsatisfactory, check fuel hoses and fuel tubes for clogging.

Is the inspection result normal?

- YES >> Replace "fuel filter and fuel pump assembly".

**FUEL PRESSURE CHECK**

< BASIC INSPECTION >

[VQ37VHR FOR MEXICO]

---

NO >> Repair or replace.

# HOW TO SET SRT CODE

< BASIC INSPECTION >

[VQ37VHR FOR MEXICO]

## HOW TO SET SRT CODE

### Description

INFOID:000000007729739

### OUTLINE

In order to set all SRTs, the self-diagnoses as in the "SRT ITEM" table must have been performed at least once. Each diagnosis may require actual driving for a long period of time under various conditions.

### SRT ITEM

The table below shows required self-diagnostic items to set the SRT to "CMPLT".

| SRT item*1<br>(CONSULT indication) | Required self-diagnostic items to set the SRT to "CMPLT" | Corresponding DTC No. |
|------------------------------------|--|-----------------------|
| CATALYST                           | Three way catalyst function                              | P0420, P0430          |
| HO2S                               | Air fuel ratio (A/F) sensor 1                            | P0133, P0153          |
|                                    | Heated oxygen sensor 2                                   | P0137, P0157          |
|                                    | Heated oxygen sensor 2                                   | P0138, P0158          |
|                                    | Heated oxygen sensor 2                                   | P0139, P0159          |
| EGR/VVT SYSTEM                     | Intake valve timing control function                     | P0011, P0021          |

\*1: Though displayed on the CONSULT screen, "HO2S HTR" is not SRT item.

### SRT SERVICE PROCEDURE

If a vehicle has failed the state emissions inspection due to one or more SRT items indicating "INCMP", review the flowchart diagnostic sequence, referring to the following flowchart.

# HOW TO SET SRT CODE

< BASIC INSPECTION >

[VQ37VHR FOR MEXICO]

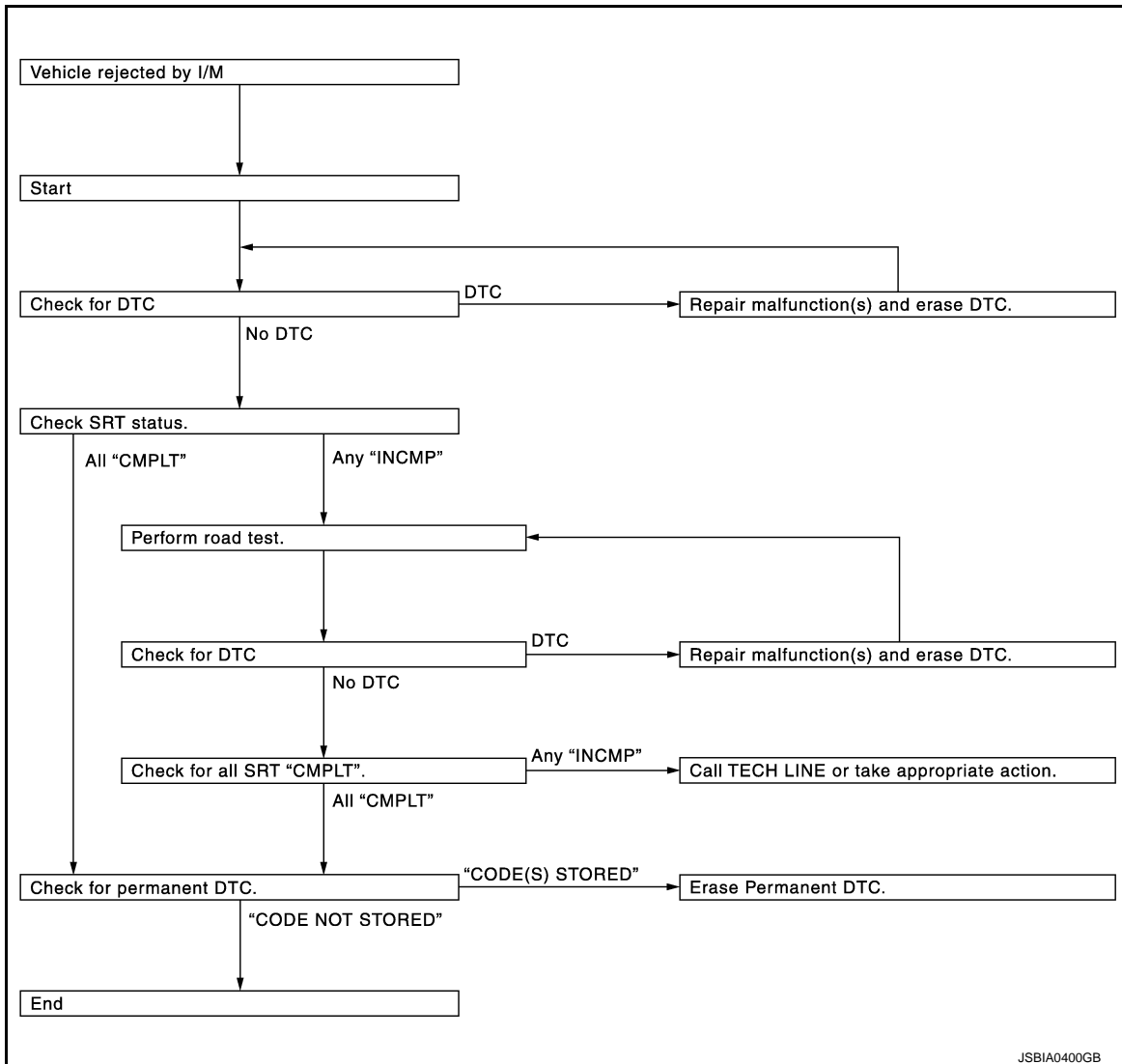

SRT Set Driving Pattern

INFOID:000000007729740

**CAUTION:**

# HOW TO SET SRT CODE

< BASIC INSPECTION >

[VQ37VHR FOR MEXICO]

Always drive the vehicle in safe manner according to traffic conditions and obey all traffic laws.

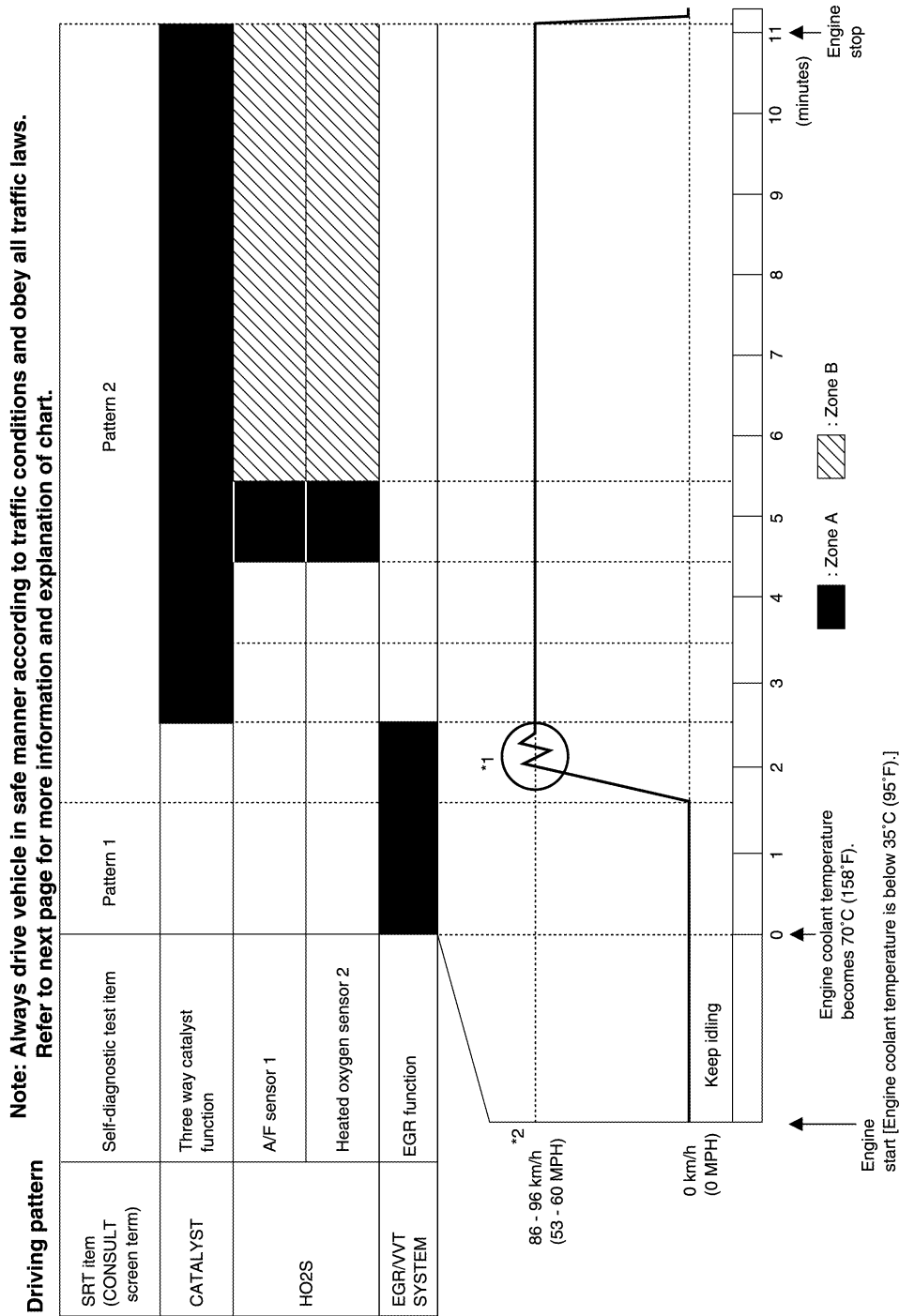

\*1: Depress the accelerator pedal until vehicle speed is 90 km/h (56 MPH), then release the accelerator pedal and keep it released for more than 10 seconds. Depress the accelerator pedal until vehicle speed is 90 km/h (56 MPH) again.

\*2: Checking the vehicle speed with GST is advised.

- The time required for each diagnosis varies with road surface conditions, weather, altitude, individual driving habits, etc.

Zone A refers to the range where the time, required for the diagnosis under normal conditions\*, is the shortest.

A  
EC  
C  
D  
E  
F  
G  
H  
I  
J  
K  
L  
M  
N  
O

P

# HOW TO SET SRT CODE

[VQ37VHR FOR MEXICO]

## < BASIC INSPECTION >

Zone B refers to the range where the diagnosis can still be performed if the diagnosis is not completed within zone A.

\*: Normal conditions refer to the following:

- Sea level
  - Flat road
  - Ambient air temperature: 20 - 30°C (68 - 86°F)
  - Diagnosis is performed as quickly as possible under normal conditions.
- Under different conditions [For example: ambient air temperature other than 20 - 30°C (68 - 86°F)], diagnosis may also be performed.

## Work Procedure

INFOID:00000000729741

### 1. CHECK DTC

Check DTC.

Is any DTC detected?

YES >> Repair malfunction(s) and erase DTC. Refer to [EC-628, "DTC Index"](#).

NO >> GO TO 2.

### 2. CHECK SRT STATUS

WITH CONSULT

Select "SRT STATUS" in "DTC & SRT CONFIRMATION" mode with CONSULT.

WITHOUT CONSULT

Perform "SRT status" mode with [EC-598, "On Board Diagnosis Function"](#).

WITH GST

Select Service \$01 with GST.

Is SRT code(s) set?

YES >> END

NO-1 >> With CONSULT: GO TO 3.

NO-2 >> Without CONSULT: GO TO 4.

### 3. DTC CONFIRMATION PROCEDURE

1. Select "SRT WORK SUPPORT" in "DTC & SRT CONFIRMATION" mode with CONSULT.
2. For SRT(s) that is not set, perform the corresponding "DTC CONFIRMATION PROCEDURE" according to the "Performance Priority" in the "SRT ITEM" table. Refer to [EC-669, "Description"](#).
3. Check DTC.

Is any DTC detected?

YES >> Repair malfunction(s) and erase DTC. Refer to [EC-628, "DTC Index"](#).

NO >> GO TO 7.

### 4. PERFORM ROAD TEST

- Check the "Performance Priority" in the "SRT ITEM" table. Refer to [EC-669, "Description"](#).
- Perform the most efficient SRT set driving pattern to set the SRT properly. Refer to [EC-670, "SRT Set Driving Pattern"](#).

In order to set all SRTs, the SRT set driving pattern must be performed at least once.

>> GO TO 5.

### 5. PATTERN 1

1. Check the vehicle condition;
  - Engine coolant temperature is -10 to 35°C (14 to 95°F).
  - Fuel tank temperature is more than 0°C (32°F).
2. Start the engine.
3. Keep engine idling until the engine coolant temperature is greater than 70°C (158°F)

#### NOTE:

ECM terminal voltage is follows;

- Engine coolant temperature
  - -10 to 35°C (14 to 95°F): 3.0 - 4.3 V
  - 70°(158°F): Less than 1.4 V



# HOW TO SET SRT CODE

[VQ37VHR FOR MEXICO]

## < BASIC INSPECTION >

- Fuel tank temperature: Less than 4.1 V  
Refer to [EC-609, "Reference Value"](#).

>> GO TO 6.

## 6.PATTERN 2

1. Drive the vehicle. And depress the accelerator pedal until vehicle speed is 90 km/h (56 MPH), then release the accelerator pedal and keep it released for more than 10 seconds.
2. Depress the accelerator pedal until vehicle speed is 90 km/h (56 MPH) again

### NOTE:

- Checking the vehicle speed with GST is advised.
- When steady-state driving is performed again even after it is interrupted, each diagnosis can be conducted. In this case, the time required for diagnosis may be extended.

>> GO TO 7.

## 7.CHECK SRT STATUS

### WITH CONSULT

Select "SRT STATUS" in "DTC & SRT CONFIRMATION" mode with CONSULT.

### WITHOUT CONSULT

Perform "SRT status" mode with [EC-598, "On Board Diagnosis Function"](#).

### WITH GST

Select Service \$01 with GST.

### Is SRT(s) set?

- YES >> END  
NO >> Call TECH LINE or take appropriate action.

A

EC

C

D

E

F

G

H

I

J

K

L

M

N

O

P

## DTC/CIRCUIT DIAGNOSIS

### TROUBLE DIAGNOSIS - SPECIFICATION VALUE

#### Description

INFOID:000000007729748

The specification (SP) value indicates the tolerance of the value that is displayed in "SPEC" in "DATA MONITOR" mode of CONSULT during normal operation of the Engine Control System. When the value in "SPEC" in "DATA MONITOR" mode is within the SP value, the Engine Control System is confirmed OK. When the value in "SPEC" in "DATA MONITOR" mode is NOT within the SP value, the Engine Control System may have one or more malfunctions.

The SP value is used to detect malfunctions that may affect the Engine Control System, but will not illuminate the MIL.

The SP value will be displayed for the following three items:

- B/FUEL SCHDL (The fuel injection pulse width programmed into ECM prior to any learned on board correction)
- A/F ALPHA-B1/B2 (The mean value of air-fuel ratio feedback correction factor per cycle)
- MAS A/F SE-B1/B2 (The signal voltage of the mass air flow sensor)

#### Component Function Check

INFOID:000000007729749

### 1. PRECONDITIONING

Make sure that all of the following conditions are satisfied.

#### TESTING CONDITION

- Vehicle driven distance: More than 5,000 km (3,107 miles)
- Barometric pressure: 98.3 - 104.3 kPa (1.003 - 1.064 kg/cm<sup>2</sup>, 14.25 - 15.12 psi)
- Atmospheric temperature: 20 - 30°C (68 - 86°F)
- Engine coolant temperature: 75 - 95°C (167 - 203°F)
- Transmission: Warmed-up
- After the engine is warmed up to normal operating temperature, drive vehicle until "ATF TEMP 1" (A/T fluid temperature sensor signal) indicates more than 60°C (140°F).
- Electrical load: Not applied
- Rear window defogger switch, air conditioner switch, lighting switch are OFF. Steering wheel is straight ahead.
- Engine speed: Idle

>> GO TO 2.

### 2. PERFORM SPEC IN DATA MONITOR MODE

#### Ⓟ With CONSULT

#### NOTE:

Perform "SPEC" in "DATA MONITOR" mode in maximum scale display.

1. Perform [EC-663. "Work Procedure"](#).
2. Select "B/FUEL SCHDL", "A/F ALPHA-B1", "A/F ALPHA-B2", "MAS A/F SE-B1" and "MAS A/F SE-B2" in "SPEC" of "DATA MONITOR" mode with CONSULT.
3. Make sure that monitor items are within the SP value.

Is the measurement value within the SP value?

- YES >> INSPECTION END  
 NO >> Go to [EC-675. "Diagnosis Procedure"](#).

# TROUBLE DIAGNOSIS - SPECIFICATION VALUE

< DTC/CIRCUIT DIAGNOSIS >

[VQ37VHR FOR MEXICO]

## Diagnosis Procedure

INFOID:000000007729750

### OVERALL SEQUENCE

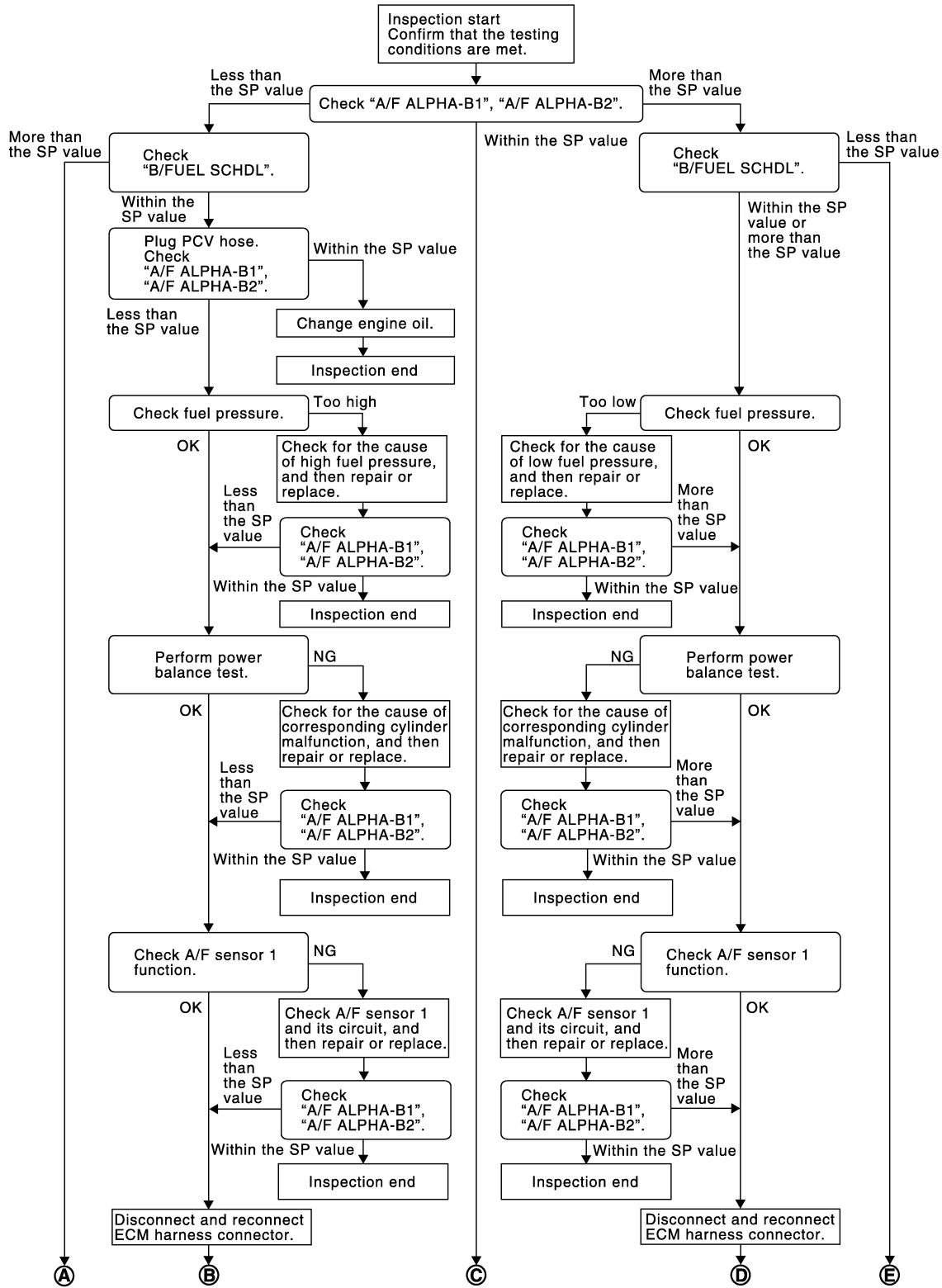

JMBIA1468GB

A  
EC  
C  
D  
E  
F  
G  
H  
I  
J  
K  
L  
M  
N  
O  
P

# TROUBLE DIAGNOSIS - SPECIFICATION VALUE

< DTC/CIRCUIT DIAGNOSIS >

[VQ37VHR FOR MEXICO]

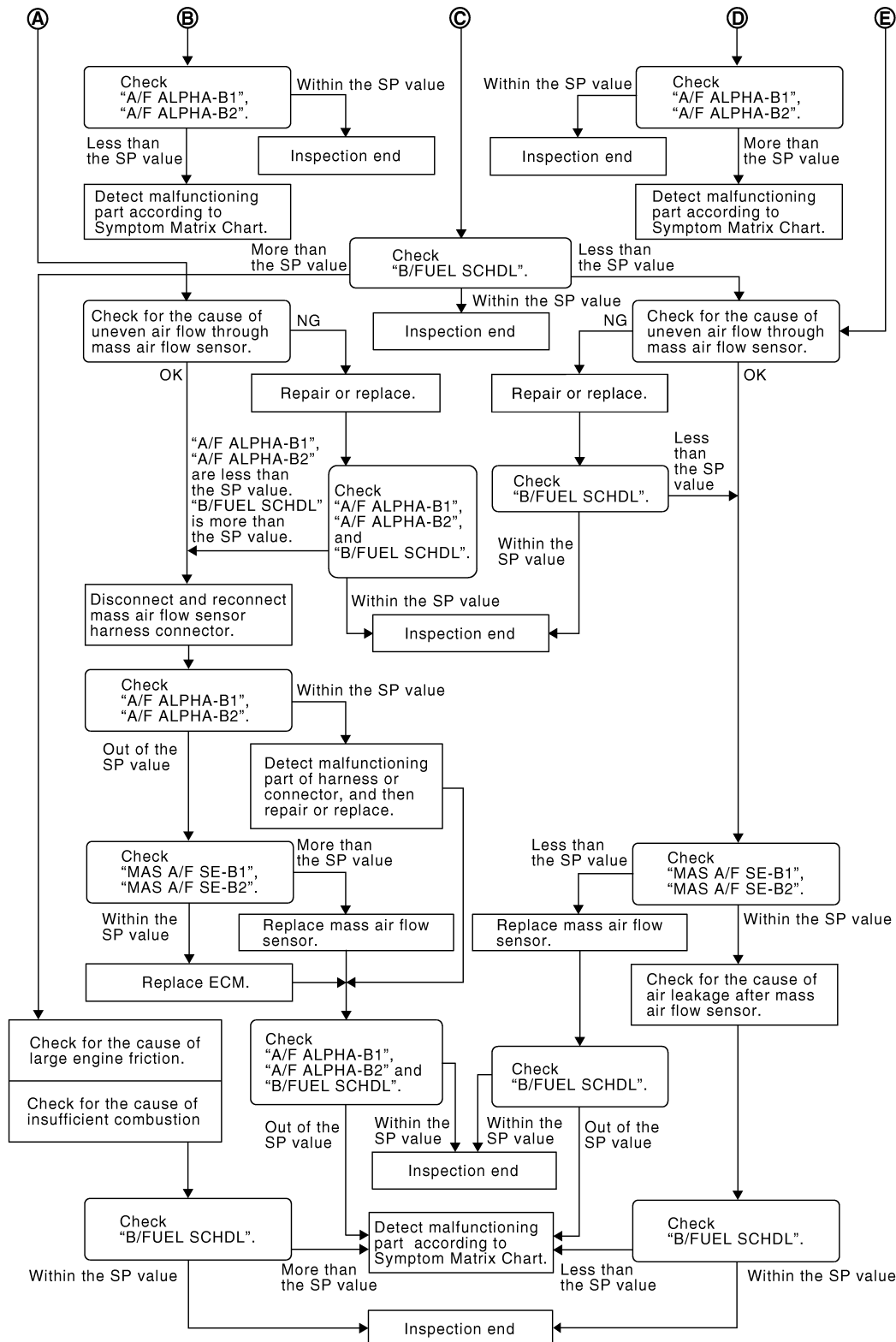

JMBIA0056GB

## DETAILED PROCEDURE

### 1. CHECK "A/F ALPHA-B1", "A/F ALPHA-B2"

#### ⓑ With CONSULT

1. Start engine.
2. Confirm that the testing conditions are met. Refer to [EC-674, "Component Function Check"](#).
3. Select "A/F ALPHA-B1", "A/F ALPHA-B2" in "SPEC" of "DATA MONITOR" mode, and make sure that each indication is within the SP value.

# TROUBLE DIAGNOSIS - SPECIFICATION VALUE

< DTC/CIRCUIT DIAGNOSIS >

[VQ37VHR FOR MEXICO]

## NOTE:

Check "A/F ALPHA-B1", "A/F ALPHA-B2" for approximately 1 minute because they may fluctuate. It is NG if the indication is out of the SP value even a little.

Is the measurement value within the SP value?

YES >> GO TO 17.

NO-1 >> Less than the SP value: GO TO 2.

NO-2 >> More than the SP value: GO TO 3.

## 2.CHECK "B/FUEL SCHDL"

Select "B/FUEL SCHDL" in "SPEC" of "DATA MONITOR" mode, and make sure that the indication is within the SP value.

Is the measurement value within the SP value?

YES >> GO TO 4.

NO >> More than the SP value: GO TO 19.

## 3.CHECK "B/FUEL SCHDL"

Select "B/FUEL SCHDL" in "SPEC" of "DATA MONITOR" mode, and make sure that the indication is within the SP value.

Is the measurement value within the SP value?

YES >> GO TO 6.

NO-1 >> More than the SP value: GO TO 6.

NO-2 >> Less than the SP value: GO TO 25.

## 4.CHECK "A/F ALPHA-B1", "A/F ALPHA-B2"

1. Stop the engine.

2. Disconnect PCV hose, and then plug it.

3. Start engine.

4. Select "A/F ALPHA-B1", "A/F ALPHA-B2" in "SPEC" of "DATA MONITOR" mode, and make sure that each indication is within the SP value.

Is the measurement value within the SP value?

YES >> GO TO 5.

NO >> GO TO 6.

## 5.CHANGE ENGINE OIL

1. Stop the engine.

2. Change engine oil.

## NOTE:

This symptom may occur when a large amount of gasoline is mixed with engine oil because of driving conditions (such as when engine oil temperature does not rise enough since a journey distance is too short during winter). The symptom will not be detected after changing engine oil or changing driving conditions.

>> INSPECTION END

## 6.CHECK FUEL PRESSURE

Check fuel pressure. (Refer to [EC-667, "Work Procedure"](#).)

Is the inspection result normal?

YES >> GO TO 9.

NO-1 >> Fuel pressure is too high: Replace "fuel filter and fuel pump assembly" and then GO TO 8.

NO-2 >> Fuel pressure is too low: GO TO 7.

## 7.DETECT MALFUNCTIONING PART

Check fuel hoses and fuel tubes for clogging.

Is the inspection result normal?

YES >> Replace "fuel filter and fuel pump assembly" and then GO TO 8.

NO >> Repair or replace and then GO TO 8.

## 8.CHECK "A/F ALPHA-B1", "A/F ALPHA-B2"

## TROUBLE DIAGNOSIS - SPECIFICATION VALUE

[VQ37VHR FOR MEXICO]

< DTC/CIRCUIT DIAGNOSIS >

1. Start engine.
2. Select "A/F ALPHA-B1", "A/F ALPHA-B2" in "SPEC" of "DATA MONITOR" mode, and make sure that each indication is within the SP value.

Is the measurement value within the SP value?

- YES >> INSPECTION END  
NO >> GO TO 9.

### 9.PERFORM POWER BALANCE TEST

1. Perform "POWER BALANCE" in "ACTIVE TEST" mode.
2. Make sure that the each cylinder produces a momentary engine speed drop.

Is the inspection result normal?

- YES >> GO TO 12.  
NO >> GO TO 10.

### 10.DETECT MALFUNCTIONING PART

Check the following bellow.

- Ignition coil and its circuit (Refer to [EC-952, "Component Function Check".](#))
- Fuel injector and its circuit (Refer to [EC-945, "Component Function Check".](#))
- Intake air leakage
- Low compression pressure (Refer to [EM-18, "Inspection".](#))

Is the inspection result normal?

- YES >> Replace fuel injector and then GO TO 11.  
NO >> Repair or replace malfunctioning part and then GO TO 11.

### 11.CHECK "A/F ALPHA-B1", "A/F ALPHA-B2"

1. Start engine.
2. Select "A/F ALPHA-B1", "A/F ALPHA-B2" in "SPEC" of "DATA MONITOR" mode, and make sure that each indication is within the SP value.

Is the measurement value within the SP value?

- YES >> INSPECTION END  
NO >> GO TO 12.

### 12.CHECK A/F SENSOR 1 FUNCTION

Perform all DTC CONFIRMATION PROCEDURE related with A/F sensor 1.

- For DTC P0130, P0150, refer to [EC-719, "DTC Logic".](#)
- For DTC P0131, P0151, refer to [EC-723, "DTC Logic".](#)
- For DTC P0132, P0152, refer to [EC-726, "DTC Logic".](#)
- For DTC P0133, P0153, refer to [EC-729, "DTC Logic".](#)
- For DTC P2A00, P2A03, refer to [EC-932, "DTC Logic".](#)

Are any DTCs detected?

- YES >> GO TO 13.  
NO >> GO TO 15.

### 13.CHECK A/F SENSOR 1 CIRCUIT

Perform Diagnosis Procedure according to corresponding DTC.

>> GO TO 14.

### 14.CHECK "A/F ALPHA-B1", "A/F ALPHA-B2"

1. Start engine.
2. Select "A/F ALPHA-B1", "A/F ALPHA-B2" in "SPEC" of "DATA MONITOR" mode, and make sure that each indication is within the SP value.

Is the measurement value within the SP value?

- YES >> INSPECTION END  
NO >> GO TO 15.

### 15.DISCONNECT AND RECONNECT ECM HARNESS CONNECTOR

1. Stop the engine.

## TROUBLE DIAGNOSIS - SPECIFICATION VALUE

< DTC/CIRCUIT DIAGNOSIS >

[VQ37VHR FOR MEXICO]

2. Disconnect ECM harness connector. Check pin terminal and connector for damage, and then reconnect it.

>> GO TO 16.

### 16.CHECK "A/F ALPHA-B1", "A/F ALPHA-B2"

1. Start engine.
2. Select "A/F ALPHA-B1", "A/F ALPHA-B2" in "SPEC" of "DATA MONITOR" mode, and make sure that each indication is within the SP value.

Is the measurement value within the SP value?

YES >> INSPECTION END

NO >> Detect malfunctioning part according to [EC-969. "Symptom Table"](#).

### 17.CHECK "B/FUEL SCHDL"

Select "B/FUEL SCHDL" in "SPEC" of "DATA MONITOR" mode, and make sure that the indication is within the SP value.

Is the measurement value within the SP value?

YES >> INSPECTION END

NO-1 >> More than the SP value: GO TO 18.

NO-2 >> Less than the SP value: GO TO 25.

### 18.DETECT MALFUNCTIONING PART

1. Check for the cause of large engine friction. Refer to the following.
  - Engine oil level is too high
  - Engine oil viscosity
  - Belt tension of power steering, alternator, A/C compressor, etc. is excessive
  - Noise from engine
  - Noise from transmission, etc.
2. Check for the cause of insufficient combustion. Refer to the following.
  - Valve clearance malfunction
  - Intake valve timing control function malfunction
  - Camshaft sprocket installation malfunction, etc.

>> Repair or replace malfunctioning part, and then GO TO 30.

### 19.CHECK INTAKE SYSTEM

Check for the cause of uneven air flow through mass air flow sensor. Refer to the following.

- Crushed air ducts
- Malfunctioning seal of air cleaner element
- Uneven dirt of air cleaner element
- Improper specification of intake air system

Is the inspection result normal?

YES >> GO TO 21.

NO >> Repair or replace malfunctioning part, and then GO TO 20.

### 20.CHECK "A/F ALPHA-B1", "A/F ALPHA-B2", AND "B/FUEL SCHDL"

Select "A/F ALPHA-B1", "A/F ALPHA-B2", and "B/FUEL SCHDL" in "SPEC" of "DATA MONITOR" mode, and make sure that each indication is within the SP value.

Is the measurement value within the SP value?

YES >> INSPECTION END

NO >> "B/FUEL SCHDL" is more, "A/F ALPHA-B1", "A/F ALPHA-B2" are less than the SP value: GO TO 21.

### 21.DISCONNECT AND RECONNECT MASS AIR FLOW SENSOR HARNESS CONNECTOR

1. Stop the engine.
2. Disconnect mass air flow sensor harness connector. Check pin terminal and connector for damage and then reconnect it again.

>> GO TO 22.

## TROUBLE DIAGNOSIS - SPECIFICATION VALUE

< DTC/CIRCUIT DIAGNOSIS >

[VQ37VHR FOR MEXICO]

---

### 22. CHECK "A/F ALPHA-B1", "A/F ALPHA-B2"

---

1. Start engine.
2. Select "A/F ALPHA-B1", "A/F ALPHA-B2" in "SPEC" of "DATA MONITOR" mode, and make sure that each indication is within the SP value.

Is the measurement value within the SP value?

YES >> Detect malfunctioning part of mass air flow sensor circuit and repair it. Refer to [EC-706, "Diagnosis Procedure"](#). Then GO TO 29.

NO >> GO TO 23.

---

### 23. CHECK "MAS A/F SE-B1", "MAS A/F SE-B2"

---

Select "MAS A/F SE-B1", "MAS A/F SE-B2" in "SPEC" of "DATA MONITOR" mode, and make sure that the indication is within the SP value.

Is the measurement value within the SP value?

YES >> GO TO 24.

NO >> More than the SP value: Replace malfunctioning mass air flow sensor, and then GO TO 29.

---

### 24. REPLACE ECM

---

1. Replace ECM.
2. Go to [EC-653, "Work Procedure"](#).

>> GO TO 29.

---

### 25. CHECK INTAKE SYSTEM

---

Check for the cause of uneven air flow through mass air flow sensor. Refer to the following.

- Crushed air ducts
- Malfunctioning seal in air cleaner element
- Uneven dirt in air cleaner element
- Improper specification in intake air system

Is the inspection result normal?

YES >> GO TO 27.

NO >> Repair or replace malfunctioning part, and then GO TO 26.

---

### 26. CHECK "B/FUEL SCHDL"

---

Select "B/FUEL SCHDL" in "SPEC" of "DATA MONITOR" mode, and make sure that the indication is within the SP value.

Is the measurement value within the SP value?

YES >> INSPECTION END

NO >> Less than the SP value: GO TO 27.

---

### 27. CHECK "MAS A/F SE-B1", "MAS A/F SE-B2"

---

Select "MAS A/F SE-B1", "MAS A/F SE-B2" in "SPEC" of "DATA MONITOR" mode, and make sure that each indication is within the SP value.

Is the measurement value within the SP value?

YES >> GO TO 28.

NO >> Less than the SP value: Replace malfunctioning mass air flow sensor, and then GO TO 30.

---

### 28. CHECK INTAKE SYSTEM

---

Check for the cause of air leak after the mass air flow sensor. Refer to the following.

- Disconnection, looseness, and cracks in air duct
- Looseness of oil filler cap
- Disconnection of oil level gauge
- Open stuck, breakage, hose disconnection, or cracks in PCV valve
- Disconnection or cracks in EVAP purge hose, stuck open EVAP canister purge volume control solenoid valve
- Malfunctioning seal in rocker cover gasket
- Disconnection, looseness, or cracks in hoses, such as a vacuum hose, connecting to intake air system parts
- Malfunctioning seal in intake air system, etc.



# TROUBLE DIAGNOSIS - SPECIFICATION VALUE

< DTC/CIRCUIT DIAGNOSIS >

[VQ37VHR FOR MEXICO]

>> GO TO 30.

## 29.CHECK "A/F ALPHA-B1", "A/F ALPHA-B2", AND "B/FUEL SCHDL"

Select "A/F ALPHA-B1", "A/F ALPHA-B2", and "B/FUEL SCHDL" in "SPEC" of "DATA MONITOR" mode, and make sure that each indication is within the SP value.

Is the measurement value within the SP value?

YES >> INSPECTION END

NO >> Detect malfunctioning part according to [EC-969. "Symptom Table"](#).

## 30.CHECK "B/FUEL SCHDL"

Select "B/FUEL SCHDL" in "SPEC" of "DATA MONITOR" mode, and then make sure that the indication is within the SP value.

Is the measurement value within the SP value?

YES >> INSPECTION END

NO >> Detect malfunctioning part according to [EC-969. "Symptom Table"](#).

A  
EC  
C  
D  
E  
F  
G  
H  
I  
J  
K  
L  
M  
N  
O  
P

# POWER SUPPLY AND GROUND CIRCUIT

< DTC/CIRCUIT DIAGNOSIS >

[VQ37VHR FOR MEXICO]

## POWER SUPPLY AND GROUND CIRCUIT

### Diagnosis Procedure

INFOID:000000007729751

#### 1. CHECK GROUND CONNECTION

1. Turn ignition switch OFF.
2. Check ground connection M95. Refer to Ground Inspection in [GI-47, "Circuit Inspection"](#).

Is the inspection result normal?

- YES >> GO TO 2.  
NO >> Repair or replace ground connection.

#### 2. CHECK ECM GROUND CIRCUIT FOR OPEN AND SHORT-I

1. Disconnect ECM harness connector.
2. Check the continuity between ECM harness connector and ground.

| ECM       |          | Ground | Continuity |
|-----------|----------|--------|------------|
| Connector | Terminal |        |            |
| F101      | 8        | Ground | Existed    |
| M107      | 123      |        |            |
|           | 124      |        |            |
|           | 127      |        |            |
|           | 128      |        |            |

3. Also check harness for short to power.

Is the inspection result normal?

- YES >> GO TO 4.  
NO >> GO TO 3.

#### 3. DETECT MALFUNCTIONING PART

Check the following.

- Harness connectors F103, M116
- Harness for open or short between ECM and ground

>> Repair open circuit or short to power in harness or connectors.

#### 4. CHECK ECM POWER SUPPLY CIRCUIT-I

1. Reconnect ECM harness connector.
2. Turn ignition switch ON.
3. Check the voltage between ECM harness connector and ground.

| ECM       |          |           |          | Voltage         |
|-----------|----------|-----------|----------|-----------------|
| +         |          | -         |          |                 |
| Connector | Terminal | Connector | Terminal |                 |
| F102      | 53       | M107      | 128      | Battery voltage |

Is the inspection result normal?

- YES >> GO TO 6.  
NO >> GO TO 5.

#### 5. DETECT MALFUNCTIONING PART

Check the following.

- Harness connectors E20, F40
- IPDM E/R harness connector E7
- 10 A fuse (No. 44)
- Harness for open or short between ECM and fuse

# POWER SUPPLY AND GROUND CIRCUIT

< DTC/CIRCUIT DIAGNOSIS >

[VQ37VHR FOR MEXICO]

>> Repair open circuit, short to ground or short to power in harness or connectors.

## 6. CHECK ECM POWER SUPPLY CIRCUIT-II

1. Turn ignition switch OFF and wait at least 10 seconds.
2. Check the voltage between ECM harness connector terminals as follows.

| ECM       |          |          | Voltage  |
|-----------|----------|----------|--|
| Connector | +        | -        |  |
|           | Terminal | Terminal |  |
| M107      | 125      | 128      | After turning ignition switch OFF, battery voltage will exist for a few seconds, then drop to approximately 0 V. |

Is the inspection result normal?

YES >> GO TO 7.

NO >> GO TO 9.

## 7. CHECK ECM POWER SUPPLY CIRCUIT-III

1. Turn ignition switch ON.
2. Check the voltage between IPDM E/R harness connector and ground.

| IPDM E/R  |          | Ground | Voltage         |
|-----------|----------|--------|-----------------|
| Connector | Terminal |        |                 |
| E5        | 5        | Ground | Battery voltage |

Is the inspection result normal?

YES >> GO TO 8.

NO >> Replace IPDM E/R. Refer to [PCS-33, "Exploded View"](#).

## 8. CHECK INTERMITTENT INCIDENT

Refer to [GI-47, "Circuit Inspection"](#).

>> INSPECTION END

## 9. CHECK ECM POWER SUPPLY CIRCUIT-IV

1. Turn ignition switch OFF and wait at least 10 seconds.
2. Check the voltage between ECM harness connector terminals as follows.

| ECM       |          |           |          | Voltage         |
|-----------|----------|-----------|----------|-----------------|
| +         |          | -         |          |                 |
| Connector | Terminal | Connector | Terminal |                 |
| F101      | 24       | M107      | 128      | Battery voltage |

Is the inspection result normal?

YES >> GO TO 13.

NO >> GO TO 10.

## 10. CHECK ECM POWER SUPPLY CIRCUIT-V

1. Disconnect ECM harness connector.
2. Disconnect IPDM E/R harness connector.
3. Check the continuity between ECM harness connector and IPDM E/R harness connector.

| ECM       |          | IPDM E/R  |          | Continuity |
|-----------|----------|-----------|----------|------------|
| Connector | Terminal | Connector | Terminal |            |
| F101      | 24       | E7        | 70       | Existed    |

4. Also check harness for short to ground and short to power.

# POWER SUPPLY AND GROUND CIRCUIT

< DTC/CIRCUIT DIAGNOSIS >

[VQ37VHR FOR MEXICO]

Is the inspection result normal?

- YES >> GO TO 12.
- NO >> GO TO 11.

## 11.DETECT MALFUNCTIONING PART

Check the following.

- Harness or connectors E20, F40
- Harness for open or short between ECM and IPDM E/R

>> Repair open circuit, short to ground or short to power in harness or connectors.

## 12.CHECK 15 A FUSE

1. Disconnect 15 A fuse (No. 51) from IPDM E/R.
2. Check 15 A fuse.

Is the inspection result normal?

- YES >> GO TO 15.
- NO >> Replace 15 A fuse.

## 13.CHECK ECM POWER SUPPLY CIRCUIT-VI

1. Disconnect ECM harness connector.
2. Disconnect IPDM E/R harness connector.
3. Check the continuity between ECM harness connector and IPDM E/R harness connector.

| ECM       |          | IPDM E/R  |          | Continuity |
|-----------|----------|-----------|----------|------------|
| Connector | Terminal | Connector | Terminal |            |
| M107      | 125      | E5        | 6        | Existed    |

4. Also check harness for short to ground and short to power.

Is the inspection result normal?

- YES >> GO TO 15.
- NO >> GO TO 14.

## 14.DETECT MALFUNCTIONING PART

Check the following.

- Harness or connectors E106, M6
- Harness for open or short between ECM and IPDM E/R

>> Repair open circuit, short to ground or short to power in harness or connectors.

## 15.CHECK INTERMITTENT INCIDENT

Refer to [GI-44. "Intermittent Incident"](#).

Is the inspection result normal?

- YES >> Replace IPDM E/R. Refer to [PCS-33. "Exploded View"](#).
- NO >> Repair open circuit, short to ground or short to power in harness or connectors.

# POWER SUPPLY AND GROUND CIRCUIT (VVEL CONTROL MODULE)

< DTC/CIRCUIT DIAGNOSIS >

[VQ37VHR FOR MEXICO]

## POWER SUPPLY AND GROUND CIRCUIT (VVEL CONTROL MODULE)

### Diagnosis Procedure

INFOID:000000007729752

#### 1. CHECK GROUND CONNECTION

1. Turn ignition switch OFF.
2. Check ground connection M95. Refer to Ground Inspection in [GI-47, "Circuit Inspection"](#).

Is the inspection result normal?

- YES >> GO TO 2.  
NO >> Repair or replace ground connection.

#### 2. CHECK VVEL CONTROL MODULE GROUND CIRCUIT FOR OPEN AND SHORT

1. Disconnect VVEL control module harness connector.
2. Check the continuity between VVEL control module harness connector and ground.

| VVEL control module |          | Ground | Continuity |
|---------------------|----------|--------|------------|
| Connector           | Terminal |        |            |
| E15                 | 14       | Ground | Existed    |

3. Also check harness for short to power.

Is the inspection result normal?

- YES >> GO TO 3.  
NO >> Repair open circuit, short to power in harness connectors.

#### 3. CHECK VVEL CONTROL MODULE POWER SUPPLY CIRCUIT-I

1. Reconnect VVEL control module harness connector.
2. Turn ignition switch ON.
3. Check the voltage between VVEL control module harness connector and ground.

| VVEL control module |          |          | Voltage  |
|---------------------|----------|----------|--|
| Connector           | +        | -        |  |
|                     | Terminal | Terminal |  |
| E15                 | 8        | 14       | After turning ignition switch OFF, battery voltage will exist for a few seconds, then drop to approximately 0 V. |

Is the inspection result normal?

- YES >> GO TO 5.  
NO >> GO TO 4.

#### 4. CHECK VVEL CONTROL MODULE POWER SUPPLY CIRCUIT-II

1. Turn ignition switch OFF and wait at least 10 seconds.
2. Disconnect VVEL control module harness connector.
3. Disconnect IPDM E/R harness connector.
4. Check the continuity between VVEL control module harness connector and IPDM E/R harness connector.

| VVEL control module |          | IPDM E/R  |          | Continuity |
|---------------------|----------|-----------|----------|------------|
| Connector           | Terminal | Connector | Terminal |            |
| E15                 | 8        | E7        | 49       | Existed    |

5. Also check harness for short to ground and short to power.

Is the inspection result normal?

- YES >> [EC-682, "Diagnosis Procedure"](#)  
NO >> Repair open circuit, short to ground or short to power in harness or connectors.

#### 5. CHECK INTERMITTENT INCIDENT

Refer to [GI-44, "Intermittent Incident"](#).

## POWER SUPPLY AND GROUND CIRCUIT (VVEL CONTROL MODULE)

< DTC/CIRCUIT DIAGNOSIS >

[VQ37VHR FOR MEXICO]

---

Is the inspection result normal?

YES >> Replace IPDM E/R. Refer to [PCS-33, "Exploded View"](#).

NO >> Repair open circuit, short to ground or short to power in harness or connectors.

# U0101 CAN COMM CIRCUIT

< DTC/CIRCUIT DIAGNOSIS >

[VQ37VHR FOR MEXICO]

## U0101 CAN COMM CIRCUIT

### Description

INFOID:000000007729753

CAN (Controller Area Network) is a serial communication line for real time application. It is an on-vehicle multiplex communication line with high data communication speed and excellent error detection ability. Many electronic control units are equipped onto a vehicle, and each control unit shares information and links with other control units during operation (not independent). In CAN communication, control units are connected with 2 communication lines (CAN H line, CAN L line) allowing a high rate of information transmission with less wiring. Each control unit transmits/receives data but selectively reads required data only.

### DTC Logic

INFOID:000000007729754

### DTC DETECTION LOGIC

| DTC No. | Trouble diagnosis name      | DTC detecting condition  | Possible cause   |
|---------|-----------------------------|--|--|
| U0101   | Lost communication with TCM | When ECM is not transmitting or receiving CAN communication signal of OBD (emission related diagnosis) with TCM for 2 seconds or more. | <ul style="list-style-type: none"><li>CAN communication line between TCM and ECM (CAN communication line is open or shorted)</li></ul> |

### DTC CONFIRMATION PROCEDURE

#### 1. PERFORM DTC CONFIRMATION PROCEDURE

- Turn ignition switch ON and wait at least 3 seconds.
- Check DTC.

Is DTC detected?

- YES >> [EC-687, "Diagnosis Procedure"](#).  
NO >> INSPECTION END

### Diagnosis Procedure

INFOID:000000007729755

Go to [LAN-25, "Trouble Diagnosis Flow Chart"](#).

# U1001 CAN COMM CIRCUIT

< DTC/CIRCUIT DIAGNOSIS >

[VQ37VHR FOR MEXICO]

## U1001 CAN COMM CIRCUIT

### Description

INFOID:000000007729759

CAN (Controller Area Network) is a serial communication line for real time application. It is an on-vehicle multiplex communication line with high data communication speed and excellent error detection ability. Many electronic control units are equipped onto a vehicle, and each control unit shares information and links with other control units during operation (not independent). In CAN communication, control units are connected with 2 communication lines (CAN H line, CAN L line) allowing a high rate of information transmission with less wiring. Each control unit transmits/receives data but selectively reads required data only.

### DTC Logic

INFOID:000000007729760

### DTC DETECTION LOGIC

| DTC No. | Trouble diagnosis name | DTC detecting condition   | Possible cause  |
|---------|------------------------|---|---|
| U1001   | CAN communication line | When ECM is not transmitting or receiving CAN communication signal other than OBD (emission related diagnosis) for 2 seconds or more. | <ul style="list-style-type: none"><li>Harness or connectors (CAN communication line is open or shorted)</li></ul> |

### DTC CONFIRMATION PROCEDURE

#### 1. PERFORM DTC CONFIRMATION PROCEDURE

1. Turn ignition switch ON and wait at least 3 seconds.
2. Check DTC.

#### Is DTC detected?

- YES >> [EC-688, "Diagnosis Procedure"](#).  
NO >> INSPECTION END

### Diagnosis Procedure

INFOID:000000007729761

Go to [LAN-25, "Trouble Diagnosis Flow Chart"](#).



# U1003 CAN COMM CIRCUIT

< DTC/CIRCUIT DIAGNOSIS >

[VQ37VHR FOR MEXICO]

## U1003 CAN COMM CIRCUIT

### Description

INFOID:000000007729762

CAN (Controller Area Network) is a serial communication line for real time application. It is an on-vehicle multiplex communication line with high data communication speed and excellent error detection ability. ECM and VVEL control module are connected with two communication lines (CAN H line and CAN L line) and transmit/receive data. ECM shares information and links with the VVEL control module during operation.

### DTC Logic

INFOID:000000007729763

#### DTC DETECTION LOGIC

##### NOTE:

If DTC U1003 is displayed with DTC P0607, first perform the trouble diagnosis for DTC P0607. Refer to [EC-821, "DTC Logic"](#).

| DTC No. | Trouble diagnosis name                      | DTC detecting condition   | Possible cause   |
|---------|---|---|--|
| U1003   | Lost communication with VVEL control module | CAN communication signal other than OBD (emission related diagnosis) is not received between VVEL control module and ECM for 2 seconds or more. | <ul style="list-style-type: none"> <li>• Harness or connectors (VVEL CAN communication line is open or shorted)</li> <li>• ECM</li> <li>• VVEL control module</li> </ul> |

#### DTC CONFIRMATION PROCEDURE

##### 1. PRECONDITIONING

##### TESTING CONDITION:

Before performing the following procedure, confirm that battery voltage is more than 10 V at idle.

>> GO TO 2.

##### 2. PERFORM DTC CONFIRMATION PROCEDURE

1. Turn ignition switch ON and wait at least 3 seconds.
2. Check DTC.

Is DTC detected?

- YES >> Go to [EC-689, "Diagnosis Procedure"](#).  
 NO >> INSPECTION END

### Diagnosis Procedure

INFOID:000000007729764

##### 1. CHECK VVEL CAN COMMUNICATION CIRCUIT

1. Turn ignition switch OFF.
2. Disconnect ECM harness connector.
3. Disconnect VVEL control module harness connector.
4. Check the continuity between ECM harness connector and VVEL control module harness connector.

| ECM       |          | VVEL control module |          | Continuity |
|-----------|----------|---------------------|----------|------------|
| Connector | Terminal | Connector           | Terminal |            |
| F102      | 54       | E15                 | 24       | Existed    |
|           | 55       |                     | 11       |            |

5. Also check harness for short to ground and power.

Is the inspection result normal?

- YES >> GO TO 3.  
 NO >> GO TO 2.

##### 2. DETECT MALFUNCTIONING PART

Check the following.

- Harness connector E20, F40

# U1003 CAN COMM CIRCUIT

[VQ37VHR FOR MEXICO]

< DTC/CIRCUIT DIAGNOSIS >

- Harness for open or short between ECM and VVEL control module

>> Repair open circuit or short to ground or short to power in harness or connectors.

## 3.CHECK INTERMITTENT INCIDENT

---

Refer to [GI-44, "Intermittent Incident"](#).

Is the inspection result normal?

YES >> GO TO 4.

NO >> Repair or replace.

## 4.REPLACE VVEL CONTROL MODULE

---

1. Replace VVEL control module.
2. Go to [EC-654, "Work Procedure"](#).

>> GO TO 5.

## 5.PERFORM DTC CONFIRMATION PROCEDURE

---

1. Reconnect all harness connectors disconnected.
2. Turn ignition switch ON.
3. Erase DTC.
4. Perform DTC Confirmation Procedure.  
See [EC-689, "DTC Logic"](#).
5. Check DTC.

Is the DTC U1003 displayed again?

YES >> GO TO 6.

NO >> INSPECTION END

## 6.REPLACE ECM

---

1. Replace ECM.
2. Go to [EC-653, "Work Procedure"](#).

>> INSPECTION END

# U1024 CAN COMM CIRCUIT

< DTC/CIRCUIT DIAGNOSIS >

[VQ37VHR FOR MEXICO]

## U1024 CAN COMM CIRCUIT

### Description

INFOID:000000007729765

CAN (Controller Area Network) is a serial communication line for real time application. It is an on-vehicle multiplex communication line with high data communication speed and excellent error detection ability. ECM and VVEL control module are connected with two communication lines (CAN H line and CAN L line) and transmit/receive data. ECM shares information and links with the VVEL control module during operation.

### DTC Logic

INFOID:000000007729766

#### DTC DETECTION LOGIC

##### NOTE:

If DTC U1024 is displayed with DTC P0607, first perform the trouble diagnosis for DTC P0607.

Refer to [EC-821, "DTC Logic"](#).

| DTC No. | Trouble diagnosis name | DTC detecting condition   | Possible cause  |
|---------|------------------------|---|---|
| U1024   | VVEL CAN communication | <ul style="list-style-type: none"><li>When VVEL control module cannot transmit/receive can communication signal from ECM.</li><li>When detecting error during the initial diagnosis of CAN controller of VVEL control module.</li></ul> | <ul style="list-style-type: none"><li>Harness or connectors (CAN communication line is open or shorted)</li><li>ECM</li><li>VVEL control module</li></ul> |

#### DTC CONFIRMATION PROCEDURE

##### 1. PRECONDITIONING

##### TESTING CONDITION:

Before performing the following procedure, confirm that battery voltage is more than 10 V at idle.

>> GO TO 2.

##### 2. PERFORM DTC CONFIRMATION PROCEDURE

- Turn ignition switch ON and wait at least 3 seconds.
- Check DTC.

##### Is DTC detected?

YES >> Go to [EC-691, "Diagnosis Procedure"](#).  
NO >> INSPECTION END

### Diagnosis Procedure

INFOID:000000007729767

##### 1. CHECK VVEL CAN COMMUNICATION CIRCUIT

- Turn ignition switch OFF.
- Disconnect ECM harness connector.
- Disconnect VVEL control module harness connector.
- Check the continuity between ECM harness connector and VVEL control module harness connector.

| ECM       |          | VVEL control module |          | Continuity |
|-----------|----------|---------------------|----------|------------|
| Connector | Terminal | Connector           | Terminal |            |
| F102      | 54       | E15                 | 24       | Existed    |
|           | 55       |                     | 11       |            |

- Also check harness for short to ground and power.

##### Is the inspection result normal?

YES >> GO TO 3.  
NO >> GO TO 2.

##### 2. DETECT MALFUNCTIONING PART

# U1024 CAN COMM CIRCUIT

[VQ37VHR FOR MEXICO]

< DTC/CIRCUIT DIAGNOSIS >

Check the following.

- Harness connector E20, F40
- Harness for open or short between ECM and VVEL control module

>> Harness for open or short between ECM and VVEL control module

## 3. CHECK INTERMITTENT INCIDENT

---

Refer to [GI-44, "Intermittent Incident"](#).

Is the inspection result normal?

YES >> GO TO 4.

NO >> Repair or replace.

## 4. REPLACE VVEL CONTROL MODULE

---

1. Replace VVEL control module.
2. Go to [EC-654, "Work Procedure"](#).

>> GO TO 5.

## 5. PERFORM DTC CONFIRMATION PROCEDURE

---

1. Reconnect all harness connectors disconnected.
2. Turn ignition switch ON.
3. Erase DTC.
4. Perform DTC Confirmation Procedure.  
See [EC-691, "DTC Logic"](#).

Is the DTC U1024 displayed again?

YES >> GO TO 6.

NO >> INSPECTION END

## 6. REPLACE ECM

---

1. Replace ECM.
2. Go to [EC-653, "Work Procedure"](#).

>> INSPECTION END

# P0011, P0021 IVT CONTROL

< DTC/CIRCUIT DIAGNOSIS >

[VQ37VHR FOR MEXICO]

## P0011, P0021 IVT CONTROL

### DTC Logic

INFOID:000000007729768

### DTC DETECTION LOGIC

#### NOTE:

- If DTC P0011 or P0021 is displayed with DTC P0075 or P0081, first perform the trouble diagnosis for DTC P0075, P0081. Refer to [EC-703, "DTC Logic"](#).
- If DTC P0011 or P0021 is displayed with DTC P0524, first perform the trouble diagnosis for DTC P0524. Refer to [EC-812, "DTC Logic"](#).

| DTC No. | Trouble diagnosis name                           | Detecting condition  | Possible cause   |
|---------|--|--|--|
| P0011   | Intake valve timing control performance (bank 1) | There is a gap between angle of target and phase-control angle degree. | <ul style="list-style-type: none"><li>• Crankshaft position sensor (POS)</li><li>• Camshaft position sensor (PHASE)</li><li>• Intake valve control solenoid valve</li><li>• Accumulation of debris to the signal pick-up portion of the camshaft</li><li>• Timing chain installation</li><li>• Foreign matter caught in the oil groove for intake valve timing control</li></ul> |
| P0021   | Intake valve timing control performance (bank 2) |  |  |

### DTC CONFIRMATION PROCEDURE

#### 1. PRECONDITIONING

If DTC Confirmation Procedure has been previously conducted, always perform the following procedure before conducting the next test.

1. Turn ignition switch OFF and wait at least 10 seconds.
2. Turn ignition switch ON.
3. Turn ignition switch OFF and wait at least 10 seconds.

#### TESTING CONDITION:

Before performing the following procedure, confirm that battery voltage is between 10 V and 16 V at idle.

>> GO TO 2.

#### 2. PERFORM DTC CONFIRMATION PROCEDURE-I

1. Turn ignition switch ON and select "DATA MONITOR" mode with CONSULT.
2. Start engine and warm it up to the normal operating temperature.
3. Maintain the following conditions for at least 6 consecutive seconds. Hold the accelerator pedal as steady as possible.

|                |                        |
|----------------|------------------------|
| ENG SPEED      | 525 - 2,000 rpm        |
| COOLAN TEMP/S  | More than 60°C (140°F) |
| Selector lever | P or N position        |

4. Let engine idle for 10 seconds.
5. Check 1st trip DTC.

Is 1st trip DTC detected?

- YES >> Go to [EC-694, "Diagnosis Procedure"](#)  
NO >> GO TO 3.

#### 3. PERFORM DTC CONFIRMATION PROCEDURE-II

1. Select "DATA MONITOR" mode with CONSULT.
2. Maintain the following conditions for at least 20 consecutive seconds.

|               |  |
|---------------|--|
| ENG SPEED     | 1,700 - 3,175 rpm (A constant rotation is maintained.) |
| COOLAN TEMP/S | More than 70°C (158°F)                                 |

# P0011, P0021 IVT CONTROL

[VQ37VHR FOR MEXICO]

< DTC/CIRCUIT DIAGNOSIS >

|                  |   |
|------------------|---|
| Selector lever   | 1st or 2nd position   |
| Driving location | Driving vehicle uphill<br>(Increased engine load will help maintain the driving conditions required for this test.) |

## CAUTION:

**Always drive at a safe speed.**

3. Check 1st trip DTC.

Is 1st trip DTC detected?

YES >> Go to [EC-694, "Diagnosis Procedure"](#)

NO >> INSPECTION END

## Diagnosis Procedure

INFOID:000000007729769

### 1. CHECK OIL PRESSURE WARNING LAMP

1. Start engine.
2. Check oil pressure warning lamp and confirm it is not illuminated.

Is oil pressure warning lamp illuminated?

YES >> Go to [LU-7, "Inspection"](#).

NO >> GO TO 2.

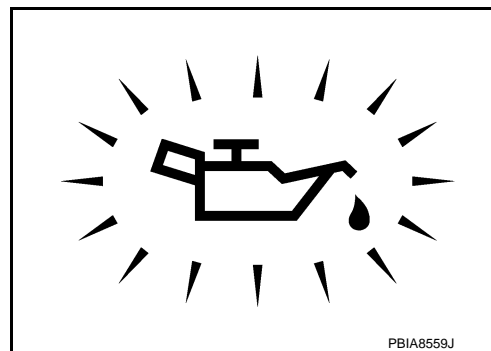

PBIA8559J

### 2. CHECK INTAKE VALVE TIMING CONTROL SOLENOID VALVE

Refer to [EC-695, "Component Inspection"](#).

Is the inspection result normal?

YES >> GO TO 3.

NO >> Replace malfunctioning intake valve timing control solenoid valve. Refer to [EM-52, "Exploded View"](#).

### 3. CHECK CRANKSHAFT POSITION SENSOR (POS)

Refer to [EC-781, "Component Inspection"](#).

Is the inspection result normal?

YES >> GO TO 4.

NO >> Replace crankshaft position sensor (POS). Refer to [EM-123, "Exploded View"](#).

### 4. CHECK CAMSHAFT POSITION SENSOR (PHASE)

Refer to [EC-786, "Component Inspection"](#).

Is the inspection result normal?

YES >> GO TO 5.

NO >> Replace malfunctioning camshaft position sensor (PHASE). Refer to [EM-52, "Exploded View"](#).

### 5. CHECK CAMSHAFT (INTAKE)

Check the following.

# P0011, P0021 IVT CONTROL

[VQ37VHR FOR MEXICO]

## < DTC/CIRCUIT DIAGNOSIS >

- Accumulation of debris on the signal plate of camshaft front end
- Chipping signal plate of camshaft front end

Is the inspection result normal?

YES >> GO TO 6.

NO >> Remove debris and clean the signal plate of camshaft front end or replace camshaft. Refer to [EM-96, "Exploded View"](#).

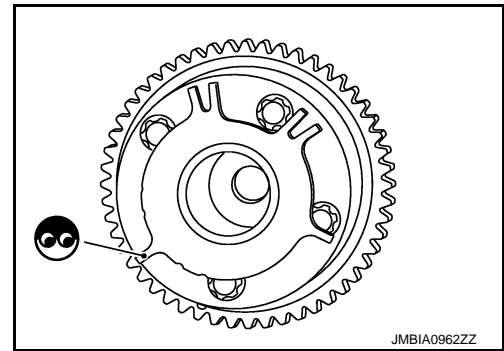

## 6.CHECK TIMING CHAIN INSTALLATION

Check service records for any recent repairs that may cause timing chain misaligned.

Are there any service records that may cause timing chain misaligned?

YES >> Check timing chain installation. Refer to [EM-53, "Removal and Installation"](#).

NO >> GO TO 7.

## 7.CHECK LUBRICATION CIRCUIT

Perform "Inspection of Camshaft Sprocket (INT) Oil Groove". Refer to [EM-106, "Inspection"](#).

Is the inspection result normal?

YES >> GO TO 8.

NO >> Clean lubrication line.

## 8.CHECK INTERMITTENT INCIDENT

Refer to [GI-44, "Intermittent Incident"](#).

>> INSPECTION END

## Component Inspection

INFOID:000000007729770

## 1.CHECK INTAKE VALVE TIMING CONTROL SOLENOID VALVE-I

1. Turn ignition switch OFF.
2. Disconnect intake valve timing control solenoid valve harness connector.
3. Check resistance between intake valve timing control solenoid valve terminals as follows.

| Terminals         | Resistance ( $\Omega$ )                   |
|-------------------|---|
| 1 and 2           | 7.0 - 7.7 [at 20°C (68°F)]                |
| 1 or 2 and ground | $\infty$<br>(Continuity should not exist) |

Is the inspection result normal?

YES >> GO TO 2.

NO >> Replace malfunctioning intake valve timing control solenoid valve. Refer to [EM-52, "Exploded View"](#).

## 2.CHECK INTAKE VALVE TIMING CONTROL SOLENOID VALVE-II

1. Remove intake valve timing control solenoid valve.

## P0011, P0021 IVT CONTROL

[VQ37VHR FOR MEXICO]

### < DTC/CIRCUIT DIAGNOSIS >

2. Provide 12 V DC between intake valve timing control solenoid valve terminals 1 and 2, and then interrupt it. Make sure that the plunger moves as shown in the figure.

**CAUTION:**

**Do not apply 12 V DC continuously for 5 seconds or more. Doing so may result in damage to the coil in intake valve timing control solenoid valve.**

**NOTE:**

**Always replace O-ring when intake valve timing control solenoid valve is removed.**

Is the inspection result normal?

YES >> INSPECTION END

NO >> Replace malfunctioning intake valve timing control solenoid valve. Refer to [EM-52. "Exploded View"](#).

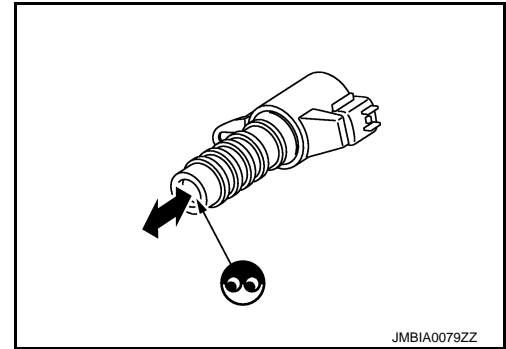



# P0031, P0032, P0051, P0052 A/F SENSOR 1 HEATER

< DTC/CIRCUIT DIAGNOSIS >

[VQ37VHR FOR MEXICO]

## P0031, P0032, P0051, P0052 A/F SENSOR 1 HEATER

### DTC Logic

INFOID:000000007729771

### DTC DETECTION LOGIC

| DTC No. | Trouble diagnosis name   | DTC detecting condition   | Possible cause  |
|---------|--|---|---|
| P0031   | Air fuel ratio (A/F) sensor 1 heater (bank 1) control circuit low  | The current amperage in the A/F sensor 1 heater circuit is out of the normal range.<br>(An excessively low voltage signal is sent to ECM through the A/F sensor 1 heater.)  | <ul style="list-style-type: none"><li>• Harness or connectors (The A/F sensor 1 heater circuit is open or shorted.)</li><li>• A/F sensor 1 heater</li></ul> |
| P0032   | Air fuel ratio (A/F) sensor 1 heater (bank 1) control circuit high | The current amperage in the A/F sensor 1 heater circuit is out of the normal range.<br>(An excessively high voltage signal is sent to ECM through the A/F sensor 1 heater.) | <ul style="list-style-type: none"><li>• Harness or connectors (The A/F sensor 1 heater circuit is shorted.)</li><li>• A/F sensor 1 heater</li></ul>         |
| P0051   | Air fuel ratio (A/F) sensor 1 heater (bank 2) control circuit low  | The current amperage in the A/F sensor 1 heater circuit is out of the normal range.<br>(An excessively low voltage signal is sent to ECM through the A/F sensor 1 heater.)  | <ul style="list-style-type: none"><li>• Harness or connectors (The A/F sensor 1 heater circuit is open or shorted.)</li><li>• A/F sensor 1 heater</li></ul> |
| P0052   | Air fuel ratio (A/F) sensor 1 heater (bank 2) control circuit high | The current amperage in the A/F sensor 1 heater circuit is out of the normal range.<br>(An excessively high voltage signal is sent to ECM through the A/F sensor 1 heater.) | <ul style="list-style-type: none"><li>• Harness or connectors (The A/F sensor 1 heater circuit is shorted.)</li><li>• A/F sensor 1 heater</li></ul>         |

### DTC CONFIRMATION PROCEDURE

#### 1. PRECONDITIONING

If DTC Confirmation Procedure has been previously conducted, always perform the following procedure before conducting the next test.

1. Turn ignition switch OFF and wait at least 10 seconds.
2. Turn ignition switch ON.
3. Turn ignition switch OFF and wait at least 10 seconds.

#### TESTING CONDITION:

Before performing the following procedure, confirm that battery voltage is between 10.5 V and 16 V at idle.

>> GO TO 2.

#### 2. PERFORM DTC CONFIRMATION PROCEDURE

1. Start engine and let it idle for at least 10 seconds.
2. Check 1st trip DTC.

Is 1st trip DTC detected?

- YES >> Go to [EC-697, "Diagnosis Procedure"](#).  
NG >> INSPECTION END

### Diagnosis Procedure

INFOID:000000007729772

#### 1. CHECK GROUND CONNECTION

1. Turn ignition switch OFF.
2. Check ground connection M95. Refer to Ground Inspection in [GI-47, "Circuit Inspection"](#).

Is the inspection result normal?

- YES >> GO TO 2.  
NO >> Repair or replace ground connection.

#### 2. CHECK AIR FUEL RATIO (A/F) SENSOR 1 POWER SUPPLY CIRCUIT

1. Disconnect air fuel ratio (A/F) sensor 1 harness connector.
2. Turn ignition switch ON.
3. Check the voltage between A/F sensor 1 harness connector and ground.

# P0031, P0032, P0051, P0052 A/F SENSOR 1 HEATER

< DTC/CIRCUIT DIAGNOSIS >

[VQ37VHR FOR MEXICO]

| DTC          | A/F sensor 1 |           |          | Ground | Voltage         |
|--------------|--------------|-----------|----------|--------|-----------------|
|              | Bank         | Connector | Terminal |        |                 |
| P0031, P0032 | 1            | F74       | 4        | Ground | Battery voltage |
| P0051, P0052 | 2            | F75       | 4        |        |                 |

Is the inspection result normal?

YES >> GO TO 4.

NO >> GO TO 3.

## 3. DETECT MALFUNCTIONING PART

Check the following.

- Harness connectors E20, F40
- IPDM E/R harness connector E7
- 15 A fuse (No. 45)
- Harness for open or short between A/F sensor 1 and fuse

>> Repair or replace harness or connectors.

## 4. CHECK A/F SENSOR 1 HEATER OUTPUT SIGNAL CIRCUIT

1. Turn ignition switch OFF.
2. Disconnect ECM harness connector.
3. Check the continuity between A/F sensor 1 harness connector and ECM harness connector.

| DTC          | A/F sensor 1 |           |          | ECM       |          | Continuity |
|--------------|--------------|-----------|----------|-----------|----------|------------|
|              | Bank         | Connector | Terminal | Connector | Terminal |            |
| P0031, P0032 | 1            | F74       | 3        | F101      | 1        | Existed    |
| P0051, P0052 | 2            | F75       | 3        |           | 5        |            |

4. Also check harness for short to ground and short to power.

Is the inspection result normal?

YES >> GO TO 5.

NO >> Repair open circuit, short to ground or short to power in harness or connectors.

## 5. CHECK A/F SENSOR 1 HEATER

Refer to [EC-699, "Component Inspection"](#).

Is the inspection result normal?

YES >> GO TO 7.

NO >> GO TO 6.

## 6. REPLACE AIR FUEL RATIO (A/F) SENSOR 1

Replace malfunctioning air fuel ratio (A/F) sensor 1.

### CAUTION:

- Discard any A/F sensor which has been dropped from a height of more than 0.5 m (19.7 in) onto a hard surface such as a concrete floor; use a new one.
- Before installing new A/F sensor, clean exhaust system threads using Oxygen Sensor Thread Cleaner [commercial service tool (J-43897-18 or J-43897-12)] and approved Anti-seize Lubricant (commercial service tool).

>> INSPECTION END

## 7. CHECK INTERMITTENT INCIDENT

Perform [GI-44, "Intermittent Incident"](#).

>> Repair or replace.

# P0031, P0032, P0051, P0052 A/F SENSOR 1 HEATER

< DTC/CIRCUIT DIAGNOSIS >

[VQ37VHR FOR MEXICO]

## Component Inspection

INFOID:000000007729773

### 1. CHECK AIR FUEL RATIO (A/F) SENSOR 1

1. Turn ignition switch OFF.
2. Disconnect A/F sensor 1 harness connector.
3. Check resistance between A/F sensor 1 terminals as follows.

| Terminal   | Resistance ( $\Omega$ )       |
|------------|-------------------------------|
| 3 and 4    | 1.98 - 2.66 [at 25°C (77°F)]  |
| 3 and 1, 2 | $\infty$                      |
| 4 and 1, 2 | (Continuity should not exist) |

Is the inspection result normal?

- YES >> INSPECTION END  
NO >> GO TO 2.

### 2. REPLACE AIR FUEL RATIO (A/F) SENSOR 1

Replace malfunctioning air fuel ratio (A/F) sensor 1.

**CAUTION:**

- Discard any A/F sensor which has been dropped from a height of more than 0.5 m (19.7 in) onto a hard surface such as a concrete floor; use a new one.
- Before installing new A/F sensor, clean exhaust system threads using Heated Oxygen Sensor Thread Cleaner [commercial service tool (J-43897-18 or J-43897-12)] and approved Anti-seize Lubricant (commercial service tool).

>> INSPECTION END

A  
EC  
C  
D  
E  
F  
G  
H  
I  
J  
K  
L  
M  
N  
O  
P

# P0037, P0038, P0057, P0058 HO2S2 HEATER

< DTC/CIRCUIT DIAGNOSIS >

[VQ37VHR FOR MEXICO]

## P0037, P0038, P0057, P0058 HO2S2 HEATER

### DTC Logic

INFOID:000000007729774

### DTC DETECTION LOGIC

| DTC No. | Trouble diagnosis name                                      | DTC detecting condition  | Possible cause  |
|---------|---|--|---|
| P0037   | Heated oxygen sensor 2 heater (bank 1) control circuit low  | The current amperage in the heated oxygen sensor 2 heater circuit is out of the normal range. (An excessively low voltage signal is sent to ECM through the heated oxygen sensor 2 heater.)  | <ul style="list-style-type: none"><li>• Harness or connectors (The heated oxygen sensor 2 heater circuit is open or shorted.)</li><li>• Heated oxygen sensor 2 heater</li></ul> |
| P0038   | Heated oxygen sensor 2 heater (bank 1) control circuit high | The current amperage in the heated oxygen sensor 2 heater circuit is out of the normal range. (An excessively high voltage signal is sent to ECM through the heated oxygen sensor 2 heater.) | <ul style="list-style-type: none"><li>• Harness or connectors (The heated oxygen sensor 2 heater circuit is shorted.)</li><li>• Heated oxygen sensor 2 heater</li></ul>         |
| P0057   | Heated oxygen sensor 2 heater (bank 2) control circuit low  | The current amperage in the heated oxygen sensor 2 heater circuit is out of the normal range. (An excessively low voltage signal is sent to ECM through the heated oxygen sensor 2 heater.)  | <ul style="list-style-type: none"><li>• Harness or connectors (The heated oxygen sensor 2 heater circuit is open or shorted.)</li><li>• Heated oxygen sensor 2 heater</li></ul> |
| P0058   | Heated oxygen sensor 2 heater (bank 2) control circuit high | The current amperage in the heated oxygen sensor 2 heater circuit is out of the normal range. (An excessively high voltage signal is sent to ECM through the heated oxygen sensor 2 heater.) | <ul style="list-style-type: none"><li>• Harness or connectors (The heated oxygen sensor 2 heater circuit is shorted.)</li><li>• Heated oxygen sensor 2 heater</li></ul>         |

### DTC CONFIRMATION PROCEDURE

#### 1. PRECONDITIONING

If DTC Confirmation Procedure has been previously conducted, always perform the following procedure before conducting the next test.

1. Turn ignition switch OFF and wait at least 10 seconds.
2. Turn ignition switch ON.
3. Turn ignition switch OFF and wait at least 10 seconds.

#### TESTING CONDITION:

Before performing the following procedure, confirm that battery voltage is between 11 V and 16 V at idle.

>> GO TO 2.

#### 2. PERFORM DTC CONFIRMATION PROCEDURE

1. Start engine and warm it up to the normal operating temperature.
2. Turn ignition switch OFF and wait at least 10 seconds.
3. Turn ignition switch ON.
4. Turn ignition switch OFF and wait at least 10 seconds.
5. Start engine and keep the engine speed between 3,500 and 4,000 rpm for at least 1 minute under no load.
6. Let engine idle for 1 minute.
7. Check 1st trip DTC.

Is 1st trip DTC detected?

- YES >> Go to [EC-700, "Diagnosis Procedure"](#).  
NO >> INSPECTION END

### Diagnosis Procedure

INFOID:000000007729775

#### 1. CHECK GROUND CONNECTION

1. Turn ignition switch OFF.
2. Check ground connection M95. Refer to Ground Inspection in [GI-47, "Circuit Inspection"](#).

Is the inspection result normal?

- YES >> GO TO 2.  
NO >> Repair or replace ground connection.

# P0037, P0038, P0057, P0058 HO2S2 HEATER

< DTC/CIRCUIT DIAGNOSIS >

[VQ37VHR FOR MEXICO]

## 2. CHECK HO2S2 POWER SUPPLY CIRCUIT

1. Disconnect heated oxygen sensor 2 (HO2S2) harness connector.
2. Turn ignition switch ON.
3. Check the voltage between HO2S2 harness connector and ground.

| DTC          | HO2S2 |           |          | Ground | Voltage         |
|--------------|-------|-----------|----------|--------|-----------------|
|              | Bank  | Connector | Terminal |        |                 |
| P0037, P0038 | 1     | F54       | 2        | Ground | Battery voltage |
| P0057, P0058 | 2     | F53       | 2        |        |                 |

Is the inspection result normal?

YES >> GO TO 4.

NO >> GO TO 3.

## 3. DETECT MALFUNCTIONING PART

Check the following.

- Harness connectors E20, F40
- IPDM E/R harness connector E7
- 15 A fuse (No. 45)
- Harness for open or short between heated oxygen sensor 2 and fuse

>> Repair open circuit, short to ground or short to power in harness or connectors.

## 4. CHECK HO2S2 OUTPUT SIGNAL CIRCUIT FOR OPEN AND SHORT

1. Turn ignition switch OFF.
2. Disconnect ECM harness connector.
3. Check the continuity between HO2S2 harness connector and ECM harness connector.

| DTC          | HO2S2 |           |          | ECM       |          | Continuity |
|--------------|-------|-----------|----------|-----------|----------|------------|
|              | Bank  | Connector | Terminal | Connector | Terminal |            |
| P0037, P0038 | 1     | F54       | 3        | F101      | 17       | Existed    |
| P0057, P0058 | 2     | F53       | 3        |           | 33       |            |

4. Also check harness for short to ground and short to power.

Is the inspection result normal?

YES >> GO TO 5.

NO >> Repair open circuit, short to ground or short to power in harness or connectors.

## 5. CHECK HEATED OXYGEN SENSOR 2 HEATER

Refer to [EC-702. "Component Inspection"](#).

Is the inspection result normal?

YES >> GO TO 7.

NO >> GO TO 6.

## 6. REPLACE HEATED OXYGEN SENSOR 2

Replace malfunctioning heated oxygen sensor 2.

### CAUTION:

- Discard any heated oxygen sensor which has been dropped from a height of more than 0.5 m (19.7 in) onto a hard surface such as a concrete floor; use a new one.
- Before installing new heated oxygen sensor, clean exhaust system threads using Oxygen Sensor Thread Cleaner [commercial service tool (J-43897-18 or J-43897-12)] and approved Anti-seize Lubricant (commercial service tool).

>> INSPECTION END

## 7. CHECK INTERMITTENT INCIDENT

# P0037, P0038, P0057, P0058 HO2S2 HEATER

< DTC/CIRCUIT DIAGNOSIS >

[VQ37VHR FOR MEXICO]

Refer to [GI-44, "Intermittent Incident"](#).

>> INSPECTION END

## Component Inspection

INFOID:00000000729776

### 1. CHECK HEATED OXYGEN SENSOR 2 HEATER

1. Turn ignition switch OFF.
2. Disconnect heated oxygen sensor 2 harness connector.
3. Check resistance between HO2S2 terminals as follows.

| Terminal      | Resistance ( $\Omega$ )       |
|---------------|-------------------------------|
| 2 and 3       | 3.4 - 4.4 [at 25°C (77°F)]    |
| 1 and 2, 3, 4 | $\infty$                      |
| 4 and 1, 2, 3 | (Continuity should not exist) |

Is the inspection result normal?

- YES >> INSPECTION END  
NO >> GO TO 2.

### 2. REPLACE HEATED OXYGEN SENSOR 2

Replace malfunctioning heated oxygen sensor 2.

**CAUTION:**

- Discard any heated oxygen sensor which has been dropped from a height of more than 0.5 m (19.7 in) onto a hard surface such as a concrete floor; use a new one.
- Before installing new oxygen sensor, clean exhaust system threads using Oxygen Sensor Thread Cleaner [commercial service tool (J-43897-18 or J-43897-12)] and approved anti-seize lubricant (commercial service tool).

>> INSPECTION END

# P0075, P0081 IVT CONTROL SOLENOID VALVE

< DTC/CIRCUIT DIAGNOSIS >

[VQ37VHR FOR MEXICO]

## P0075, P0081 IVT CONTROL SOLENOID VALVE

### DTC Logic

INFOID:000000007729780

### DTC DETECTION LOGIC

| DTC No. | Trouble diagnosis name                                      | DTC detecting condition  | Possible cause   |
|---------|---|--|--|
| P0075   | Intake valve timing control solenoid valve (bank 1) circuit | An improper voltage is sent to the ECM through intake valve timing control solenoid valve. | <ul style="list-style-type: none"> <li>• Harness or connectors (Intake valve timing control solenoid valve circuit is open or shorted.)</li> <li>• Intake valve timing control solenoid valve</li> </ul> |
| P0081   | Intake valve timing control solenoid valve (bank 2) circuit |  |  |

### DTC CONFIRMATION PROCEDURE

#### 1. PRECONDITIONING

If DTC Confirmation Procedure has been previously conducted, always perform the following procedure before conducting the next test.

1. Turn ignition switch OFF and wait at least 10 seconds.
2. Turn ignition switch ON.
3. Turn ignition switch OFF and wait at least 10 seconds.

>> GO TO 2.

#### 2. PERFORM DTC CONFIRMATION PROCEDURE

1. Start engine and let it idle for 5 seconds.
2. Check 1st trip DTC.

Is 1st trip DTC detected?

- YES >> Go to [EC-703. "Diagnosis Procedure"](#).  
 NO >> INSPECTION END

### Diagnosis Procedure

INFOID:000000007729781

#### 1. CHECK INTAKE VALVE TIMING CONTROL SOLENOID VALVE POWER SUPPLY CIRCUIT

1. Turn ignition switch OFF.
2. Disconnect intake valve timing (IVT) control solenoid valve harness connector.
3. Turn ignition switch ON.
4. Check the voltage between intake valve timing control solenoid valve harness connector and ground.

| DTC   | IVT control solenoid valve |           |          | Ground | Voltage         |
|-------|----------------------------|-----------|----------|--------|-----------------|
|       | Bank                       | Connector | Terminal |        |                 |
| P0075 | 1                          | F28       | 2        | Ground | Battery voltage |
| P0081 | 2                          | F29       | 2        |        |                 |

Is the inspection result normal?

- YES >> GO TO 3.  
 NO >> GO TO 2.

#### 2. DETECT MALFUNCTIONING PART

Check the following.

- Harness connectors E20, F40
- Harness for open or short between intake valve timing control solenoid valve and IPDM E/R

>> Repair open circuit, short to ground or short to power in harness or connectors.

#### 3. CHECK INTAKE VALVE TIMING CONTROL SOLENOID VALVE OUTPUT SIGNAL CIRCUIT FOR OPEN AND SHORT

# P0075, P0081 IVT CONTROL SOLENOID VALVE

[VQ37VHR FOR MEXICO]

## < DTC/CIRCUIT DIAGNOSIS >

1. Turn ignition switch OFF.
2. Disconnect ECM harness connector.
3. Check the continuity between intake valve timing control solenoid valve harness connector and ECM harness connector.

| DTC   | IVT control solenoid valve |           |          | ECM       |          | Continuity |
|-------|----------------------------|-----------|----------|-----------|----------|------------|
|       | Bank                       | Connector | Terminal | Connector | Terminal |            |
| P0075 | 1                          | F28       | 1        | F101      | 18       | Existed    |
| P0081 | 2                          | F29       | 1        |           | 29       |            |

4. Also check harness for short to ground and short to power.

Is the inspection result normal?

YES >> GO TO 4.

NO >> Repair open circuit, short to ground or short to power in harness or connectors.

## 4.CHECK INTAKE VALVE TIMING CONTROL SOLENOID VALVE

Refer to [EC-704, "Component Inspection"](#).

Is the inspection result normal?

YES >> GO TO 5.

NO >> Replace malfunctioning intake valve timing control solenoid valve. Refer to [EM-52, "Exploded View"](#).

## 5.CHECK INTERMITTENT INCIDENT

Refer to [GI-44, "Intermittent Incident"](#).

>> INSPECTION END

## Component Inspection

INFOID:000000007729782

### 1.CHECK INTAKE VALVE TIMING CONTROL SOLENOID VALVE-I

1. Turn ignition switch OFF.
2. Disconnect intake valve timing control solenoid valve harness connector.
3. Check resistance between intake valve timing control solenoid valve terminals as follows.

| Terminals         | Resistance ( $\Omega$ )                   |
|-------------------|---|
| 1 and 2           | 7.0 - 7.7 [at 20°C (68°F)]                |
| 1 or 2 and ground | $\infty$<br>(Continuity should not exist) |

Is the inspection result normal?

YES >> GO TO 2.

NO >> Replace malfunctioning intake valve timing control solenoid valve. Refer to [EM-52, "Exploded View"](#).

### 2.CHECK INTAKE VALVE TIMING CONTROL SOLENOID VALVE-II

1. Remove intake valve timing control solenoid valve.
2. Provide 12 V DC between intake valve timing control solenoid valve terminals 1 and 2, and then interrupt it. Make sure that the plunger moves as shown in the figure.

#### CAUTION:

Do not apply 12 V DC continuously for 5 seconds or more. Doing so may result in damage to the coil in intake valve timing control solenoid valve.

#### NOTE:

Always replace O-ring when intake valve timing control solenoid valve is removed.

Is the inspection result normal?

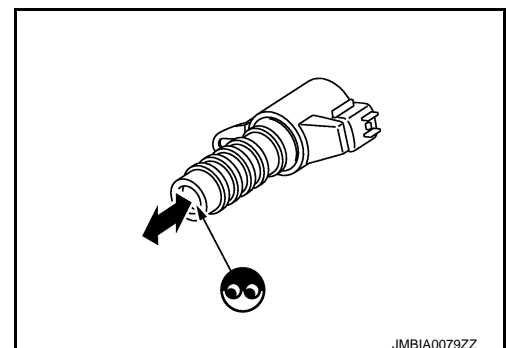



# P0075, P0081 IVT CONTROL SOLENOID VALVE

[VQ37VHR FOR MEXICO]

< DTC/CIRCUIT DIAGNOSIS >

YES >> INSPECTION END

NO >> Replace malfunctioning intake valve timing control solenoid valve. Refer to [EM-52, "Exploded View"](#).

A

EC

C

D

E

F

G

H

I

J

K

L

M

N

O

P

# P0102, P0103, P010C, P010D MAF SENSOR

< DTC/CIRCUIT DIAGNOSIS >

[VQ37VHR FOR MEXICO]

## P0102, P0103, P010C, P010D MAF SENSOR

### DTC Logic

INFOID:000000007729783

### DTC DETECTION LOGIC

| DTC No. | Trouble diagnosis name                           | DTC detecting condition                                     | Possible cause   |
|---------|--|---|--|
| P0102   | Mass air flow sensor (bank 1) circuit low input  | An excessively low voltage from the sensor is sent to ECM.  | <ul style="list-style-type: none"><li>• Harness or connectors (The sensor circuit is open or shorted.)</li><li>• Intake air leaks</li><li>• Mass air flow sensor</li></ul> |
| P0103   | Mass air flow sensor (bank 1) circuit high input | An excessively high voltage from the sensor is sent to ECM. | <ul style="list-style-type: none"><li>• Harness or connectors (The sensor circuit is open or shorted.)</li><li>• Mass air flow sensor</li></ul>                            |
| P010C   | Mass air flow sensor (bank 2) circuit low input  | An excessively low voltage from the sensor is sent to ECM.  | <ul style="list-style-type: none"><li>• Harness or connectors (The sensor circuit is open or shorted.)</li><li>• Intake air leaks</li><li>• Mass air flow sensor</li></ul> |
| P010D   | Mass air flow sensor (bank 2) circuit high input | An excessively high voltage from the sensor is sent to ECM. | <ul style="list-style-type: none"><li>• Harness or connectors (The sensor circuit is open or shorted.)</li><li>• Mass air flow sensor</li></ul>                            |

### DTC CONFIRMATION PROCEDURE

#### 1. PRECONDITIONING

If DTC Confirmation Procedure has been previously conducted, always perform the following procedure before conducting the next test.

1. Turn ignition switch OFF and wait at least 10 seconds.
2. Turn ignition switch ON.
3. Turn ignition switch OFF and wait at least 10 seconds.

#### Which DTC is detected?

P0102, P010C>>GO TO 2.

P0103, P010D>>GO TO 3.

#### 2. PERFORM DTC CONFIRMATION PROCEDURE FOR DTC P0102 AND P010C

1. Start engine and wait at least 5 seconds.
2. Check DTC.

#### Is DTC detected?

YES >> Go to [EC-706, "Diagnosis Procedure"](#).

NO >> INSPECTION END

#### 3. PERFORM DTC CONFIRMATION PROCEDURE FOR DTC P0103 AND P010D-I

1. Turn ignition switch ON and wait at least 5 seconds.
2. Check DTC.

#### Is DTC detected?

YES >> Go to [EC-706, "Diagnosis Procedure"](#).

NO >> GO TO 4.

#### 4. PERFORM DTC CONFIRMATION PROCEDURE FOR DTC P0103 AND P010D-II

1. Start engine and wait at least 5 seconds.
2. Check DTC.

#### Is DTC detected?

YES >> Go to [EC-706, "Diagnosis Procedure"](#).

NO >> INSPECTION END

### Diagnosis Procedure

INFOID:000000007729784

#### 1. INSPECTION START

# P0102, P0103, P010C, P010D MAF SENSOR

[VQ37VHR FOR MEXICO]

## < DTC/CIRCUIT DIAGNOSIS >

Confirm the detected DTC.

Which DTC is detected?

P0102, P010C>>GO TO 2.

P0103, P010D>>GO TO 3.

### 2.CHECK INTAKE SYSTEM

Check the following for connection.

- Air duct
- Vacuum hoses
- Intake air passage between air duct to intake manifold

Is the inspection result normal?

YES >> GO TO 3.

NO >> Reconnect the parts.

### 3.CHECK GROUND CONNECTION

1. Turn ignition switch OFF.
2. Check ground connection M95. Refer to Ground Inspection in [GI-47. "Circuit Inspection"](#).

Is the inspection result normal?

YES >> GO TO 4.

NO >> Repair or replace ground connection.

### 4.CHECK MAF SENSOR POWER SUPPLY CIRCUIT

1. Disconnect mass air flow (MAF) sensor harness connector.
2. Turn ignition switch ON.
3. Check the voltage between MAF sensor harness connector and ground.

| DTC          | MAF sensor |           |          | Ground | Voltage         |
|--------------|------------|-----------|----------|--------|-----------------|
|              | Bank       | Connector | Terminal |        |                 |
| P0102, P0103 | 1          | F31       | 5        | Ground | Battery voltage |
| P010C, P010D | 2          | F42       | 5        |        |                 |

Is the inspection result normal?

YES >> GO TO 6.

NO >> GO TO 5.

### 5.DETECT MALFUNCTIONING PART

Check the following.

- Harness connectors E106, M6
- Harness connectors M116, F103
- Harness for open or short between mass air flow sensor and ECM
- Harness for open or short between mass air flow sensor and IPDM E/R

>> Repair open circuit, short to ground or short to power in harness or connectors.

### 6.CHECK MAF SENSOR GROUND CIRCUIT FOR OPEN AND SHORT

1. Turn ignition switch OFF.
2. Disconnect ECM harness connector.
3. Check the continuity between MAF sensor harness connector and ECM harness connector.

| DTC          | MAF sensor |           |          | ECM       |          | Continuity |
|--------------|------------|-----------|----------|-----------|----------|------------|
|              | Bank       | Connector | Terminal | Connector | Terminal |            |
| P0102, P0103 | 1          | F31       | 4        | F102      | 68       | Existed    |
| P010C, P010D | 2          | F42       | 4        |           | 94       |            |

4. Also check harness for short to ground and short to power.

Is the inspection result normal?

YES >> GO TO 7.

# P0102, P0103, P010C, P010D MAF SENSOR

[VQ37VHR FOR MEXICO]

< DTC/CIRCUIT DIAGNOSIS >

NO >> Repair open circuit, short to ground or short to power in harness or connectors.

## 7. CHECK MAF SENSOR INPUT SIGNAL CIRCUIT FOR OPEN AND SHORT

1. Check the continuity between MAF sensor harness connector and ECM harness connector.

| DTC          | MAF sensor |           |          | ECM       |          | Continuity |
|--------------|------------|-----------|----------|-----------|----------|------------|
|              | Bank       | Connector | Terminal | Connector | Terminal |            |
| P0102, P0103 | 1          | F31       | 3        | F102      | 77       | Existed    |
| P010C, P010D | 2          | F42       | 3        |           | 79       |            |

2. Also check harness for short to ground and short to power.

Is the inspection result normal?

YES >> GO TO 8.

NO >> Repair open circuit, short to ground or short to power in harness or connectors.

## 8. CHECK MASS AIR FLOW SENSOR

Refer to [EC-708, "Component Inspection"](#).

Is the inspection result normal?

YES >> GO TO 9.

NO >> Replace malfunctioning mass air flow sensor. Refer to [EM-29, "Exploded View"](#).

## 9. CHECK INTERMITTENT INCIDENT

Refer to [GI-44, "Intermittent Incident"](#).

>> INSPECTION END

## Component Inspection

INFOID:000000007729785

### 1. CHECK MASS AIR FLOW SENSOR-I

#### With CONSULT

1. Turn ignition switch OFF.
2. Reconnect all harness connectors disconnected.
3. Start engine and warm it up to normal operating temperature.
4. Connect CONSULT and select "DATA MONITOR" mode.
5. Select "MAS A/F SE-B1" and "MAS A/F SE-B2", and check the indication.

| Monitor item                   | Condition  | Indication (V)            |
|--------------------------------|--|---------------------------|
| MAS A/F SE-B1<br>MAS A/F SE-B2 | Ignition switch ON (Engine stopped.)                             | Approx. 0.4               |
|                                | Idle (Engine is warmed-up to normal operating temperature.)      | 0.7 - 1.2                 |
|                                | 2,500 rpm (Engine is warmed-up to normal operating temperature.) | 1.3 - 1.7                 |
|                                | Idle to about 4,000 rpm  | 0.7 - 1.2 to Approx. 2.4* |

\*: Check for linear voltage rise in response to engine being increased to about 4,000 rpm.

#### Without CONSULT

1. Turn ignition switch OFF.
2. Reconnect all harness connectors disconnected.
3. Start engine and warm it up to normal operating temperature.
4. Check the voltage between ECM harness connector terminals under the following conditions.

# P0102, P0103, P010C, P010D MAF SENSOR

< DTC/CIRCUIT DIAGNOSIS >

[VQ37VHR FOR MEXICO]

| ECM       |                                       |          | Condition  | Voltage (V)               |
|-----------|---------------------------------------|----------|--|---------------------------|
| Connector | +                                     | -        |  |                           |
|           | Terminal                              | Terminal |  |                           |
| F102      | 77<br>[MAF sensor (bank 1)<br>signal] | 68       | Ignition switch ON (Engine stopped.)                             | Approx. 0.4               |
|           |                                       |          | Idle (Engine is warmed-up to normal operating temperature.)      | 0.7 - 1.2                 |
|           |                                       |          | 2,500 rpm (Engine is warmed-up to normal operating temperature.) | 1.3 - 1.7                 |
|           |                                       |          | Idle to about 4,000 rpm  | 0.7 - 1.2 to Approx. 2.4* |
|           | 79<br>[MAF sensor (bank 2)<br>signal] | 94       | Ignition switch ON (Engine stopped.)                             | Approx. 0.4               |
|           |                                       |          | Idle (Engine is warmed-up to normal operating temperature.)      | 0.7 - 1.2                 |
|           |                                       |          | 2,500 rpm (Engine is warmed-up to normal operating temperature.) | 1.3 - 1.7                 |
|           |                                       |          | Idle to about 4,000 rpm  | 0.7 - 1.2 to Approx. 2.4* |

\*: Check for linear voltage rise in response to engine being increased to about 4,000 rpm.

## Is the inspection result normal?

YES >> INSPECTION END

NO >> GO TO 2.

## 2. CHECK FOR THE CAUSE OF UNEVEN AIR FLOW THROUGH MASS AIR FLOW SENSOR

- Turn ignition switch OFF.
- Check for the cause of uneven air flow through mass air flow sensor. Refer to the following.
  - Crushed air ducts
  - Malfunctioning seal of air cleaner element
  - Uneven dirt of air cleaner element
  - Improper specification of intake air system parts

## Is the inspection result normal?

YES >> GO TO 4.

NO >> GO TO 3.

## 3. CHECK MASS AIR FLOW SENSOR-II

### With CONSULT

- Repair or replace malfunctioning part.
- Start engine and warm it up to normal operating temperature.
- Connect CONSULT and select "DATA MONITOR" mode.
- Select "MAS A/F SE-B1" and "MAS A/F SE-B2", and check the indication.

| Monitor item                   | Condition  | Indication (V)            |
|--------------------------------|--|---------------------------|
| MAS A/F SE-B1<br>MAS A/F SE-B2 | Ignition switch ON (Engine stopped.)                             | Approx. 0.4               |
|                                | Idle (Engine is warmed-up to normal operating temperature.)      | 0.7 - 1.2                 |
|                                | 2,500 rpm (Engine is warmed-up to normal operating temperature.) | 1.3 - 1.7                 |
|                                | Idle to about 4,000 rpm  | 0.7 - 1.2 to Approx. 2.4* |

\*: Check for linear voltage rise in response to engine being increased to about 4,000 rpm.

### Without CONSULT

- Repair or replace malfunctioning part.
- Start engine and warm it up to normal operating temperature.
- Check the voltage between ECM harness connector terminals under the following conditions.

# P0102, P0103, P010C, P010D MAF SENSOR

< DTC/CIRCUIT DIAGNOSIS >

[VQ37VHR FOR MEXICO]

| ECM       |                                       |               | Condition  | Voltage (V)               |
|-----------|---------------------------------------|---------------|--|---------------------------|
| Connector | +<br>Terminal                         | -<br>Terminal |  |                           |
| F102      | 77<br>[MAF sensor (bank 1)<br>signal] | 68            | Ignition switch ON (Engine stopped.)                             | Approx. 0.4               |
|           |                                       |               | Idle (Engine is warmed-up to normal operating temperature.)      | 0.7 - 1.2                 |
|           |                                       |               | 2,500 rpm (Engine is warmed-up to normal operating temperature.) | 1.3 - 1.7                 |
|           |                                       |               | Idle to about 4,000 rpm  | 0.7 - 1.2 to Approx. 2.4* |
|           | 79<br>[MAF sensor (bank 2)<br>signal] | 94            | Ignition switch ON (Engine stopped.)                             | Approx. 0.4               |
|           |                                       |               | Idle (Engine is warmed-up to normal operating temperature.)      | 0.7 - 1.2                 |
|           |                                       |               | 2,500 rpm (Engine is warmed-up to normal operating temperature.) | 1.3 - 1.7                 |
|           |                                       |               | Idle to about 4,000 rpm  | 0.7 - 1.2 to Approx. 2.4* |

\*: Check for linear voltage rise in response to engine being increased to about 4,000 rpm.

**Is the inspection result normal?**

- YES >> INSPECTION END  
 NO >> GO TO 4.

## 4. CHECK MASS AIR FLOW SENSOR-III

**With CONSULT**

1. Turn ignition switch OFF.
2. Disconnect mass air flow sensor harness connector and reconnect it again.
3. Start engine and warm it up to normal operating temperature.
4. Connect CONSULT and select "DATA MONITOR" mode.
5. Select "MAS A/F SE-B1" and "MAS A/F SE-B2", and check the indication.

| Monitor item                   | Condition  | Indication (V)            |
|--------------------------------|--|---------------------------|
| MAS A/F SE-B1<br>MAS A/F SE-B2 | Ignition switch ON (Engine stopped.)                             | Approx. 0.4               |
|                                | Idle (Engine is warmed-up to normal operating temperature.)      | 0.7 - 1.2                 |
|                                | 2,500 rpm (Engine is warmed-up to normal operating temperature.) | 1.3 - 1.7                 |
|                                | Idle to about 4,000 rpm  | 0.7 - 1.2 to Approx. 2.4* |

\*: Check for linear voltage rise in response to engine being increased to about 4,000 rpm.

**Without CONSULT**

1. Turn ignition switch OFF.
2. Disconnect mass air flow sensor harness connector and reconnect it again.
3. Start engine and warm it up to normal operating temperature.
4. Check the voltage between ECM harness connector terminals under the following conditions.

# P0102, P0103, P010C, P010D MAF SENSOR

< DTC/CIRCUIT DIAGNOSIS >

[VQ37VHR FOR MEXICO]

| ECM       |                                       |          | Condition  | Voltage (V)               |
|-----------|---------------------------------------|----------|--|---------------------------|
| Connector | +                                     | -        |  |                           |
|           | Terminal                              | Terminal |  |                           |
| F102      | 77<br>[MAF sensor (bank 1)<br>signal] | 68       | Ignition switch ON (Engine stopped.)                             | Approx. 0.4               |
|           |                                       |          | Idle (Engine is warmed-up to normal operating temperature.)      | 0.7 - 1.2                 |
|           |                                       |          | 2,500 rpm (Engine is warmed-up to normal operating temperature.) | 1.3 - 1.7                 |
|           |                                       |          | Idle to about 4,000 rpm  | 0.7 - 1.2 to Approx. 2.4* |
|           | 79<br>[MAF sensor (bank 2)<br>signal] | 94       | Ignition switch ON (Engine stopped.)                             | Approx. 0.4               |
|           |                                       |          | Idle (Engine is warmed-up to normal operating temperature.)      | 0.7 - 1.2                 |
|           |                                       |          | 2,500 rpm (Engine is warmed-up to normal operating temperature.) | 1.3 - 1.7                 |
|           |                                       |          | Idle to about 4,000 rpm  | 0.7 - 1.2 to Approx. 2.4* |

\*: Check for linear voltage rise in response to engine being increased to about 4,000 rpm.

## Is the inspection result normal?

YES >> INSPECTION END

NO >> Clean or replace malfunctioning mass air flow sensor. Refer to [EM-29, "Exploded View"](#).

A  
EC  
C  
D  
E  
F  
G  
H  
I  
J  
K  
L  
M  
N  
O  
P

# P0112, P0113 IAT SENSOR

< DTC/CIRCUIT DIAGNOSIS >

[VQ37VHR FOR MEXICO]

## P0112, P0113 IAT SENSOR

### DTC Logic

INFOID:000000007729796

### DTC DETECTION LOGIC

| DTC No. | Trouble diagnosis name                           | DTC detecting condition                                     | Possible cause   |
|---------|--|---|--|
| P0112   | Intake air temperature sensor circuit low input  | An excessively low voltage from the sensor is sent to ECM.  | • Harness or connectors<br>(The sensor circuit is open or shorted.)<br>• Intake air temperature sensor |
| P0113   | Intake air temperature sensor circuit high input | An excessively high voltage from the sensor is sent to ECM. |  |

### DTC CONFIRMATION PROCEDURE

#### 1. PRECONDITIONING

If DTC Confirmation Procedure has been previously conducted, always perform the following procedure before conducting the next test.

1. Turn ignition switch OFF and wait at least 10 seconds.
2. Turn ignition switch ON.
3. Turn ignition switch OFF and wait at least 10 seconds.

>> GO TO 2.

#### 2. PERFORM DTC CONFIRMATION PROCEDURE

1. Turn ignition switch ON and wait at least 5 seconds.
2. Check 1st trip DTC.

Is 1st trip DTC detected?

- YES >> Go to [EC-712, "Diagnosis Procedure"](#).  
NO >> INSPECTION END

### Diagnosis Procedure

INFOID:000000007729797

#### 1. CHECK GROUND CONNECTION

1. Turn ignition switch OFF.
2. Check ground connection M95. Refer to Ground Inspection in [GI-47, "Circuit Inspection"](#).

Is the inspection result normal?

- YES >> GO TO 2.  
NO >> Repair or replace ground connection.

#### 2. CHECK INTAKE AIR TEMPERATURE SENSOR POWER SUPPLY CIRCUIT

1. Disconnect mass air flow (MAF) sensor (intake air temperature sensor is built-into) harness connector.
2. Turn ignition switch ON.
3. Check the voltage between mass air flow sensor (bank 1) harness connector and ground.

| MAF sensor (bank 1) |          | Ground | Voltage (V) |
|---------------------|----------|--------|-------------|
| Connector           | Terminal |        |             |
| F31                 | 2        | Ground | Approx. 5   |

Is the inspection result normal?

- YES >> GO TO 3.  
NO >> Repair open circuit, short to ground or short to power in harness or connectors.

#### 3. CHECK INTAKE AIR TEMPERATURE SENSOR GROUND CIRCUIT FOR OPEN AND SHORT

1. Turn ignition switch OFF.
2. Disconnect ECM harness connector.
3. Check the continuity between mass air flow sensor (bank 1) harness connector and ECM harness connector.



# P0112, P0113 IAT SENSOR

< DTC/CIRCUIT DIAGNOSIS >

[VQ37VHR FOR MEXICO]

| MAF sensor (bank 1) |          | ECM       |          | Continuity |
|---------------------|----------|-----------|----------|------------|
| Connector           | Terminal | Connector | Terminal |            |
| F31                 | 1        | F102      | 68       | Existed    |

4. Also check harness for short to ground and short to power.

Is the inspection result normal?

YES >> GO TO 4.

NO >> Repair open circuit, short to ground or short to power in harness or connectors.

## 4.CHECK INTAKE AIR TEMPERATURE SENSOR

Refer to [EC-713, "Component Inspection"](#).

Is the inspection result normal?

YES >> GO TO 5.

NO >> Replace mass air flow sensor (with intake air temperature sensor) (bank 1). Refer to [EM-29, "Exploded View"](#).

## 5.CHECK INTERMITTENT INCIDENT

Refer to [GI-44, "Intermittent Incident"](#).

>> INSPECTION END

## Component Inspection

INFOID:000000007729798

## 1.CHECK INTAKE AIR TEMPERATURE SENSOR

1. Turn ignition switch OFF.
2. Disconnect mass air flow sensor (bank 1) harness connector.
3. Check resistance between mass air flow sensor (bank 1) terminals as follows.

| Terminals | Condition             |         | Resistance (kΩ) |
|-----------|-----------------------|---------|-----------------|
| 1 and 2   | Temperature [°C (°F)] | 25 (77) | 1.800 - 2.200   |

Is the inspection result normal?

YES >> INSPECTION END

NO >> Replace mass air flow sensor (with intake air temperature sensor) (bank 1). Refer to [EM-29, "Exploded View"](#).

# P0117, P0118 ECT SENSOR

< DTC/CIRCUIT DIAGNOSIS >

[VQ37VHR FOR MEXICO]

## P0117, P0118 ECT SENSOR

### DTC Logic

INFOID:000000007729806

### DTC DETECTION LOGIC

| DTC No. | Trouble Diagnosis Name                               | DTC Detecting Condition                                     | Possible Cause   |
|---------|--|---|--|
| P0117   | Engine coolant temperature sensor circuit low input  | An excessively low voltage from the sensor is sent to ECM.  | <ul style="list-style-type: none"><li>• Harness or connectors (The sensor circuit is open or shorted.)</li><li>• Engine coolant temperature sensor</li></ul> |
| P0118   | Engine coolant temperature sensor circuit high input | An excessively high voltage from the sensor is sent to ECM. |  |

### DTC CONFIRMATION PROCEDURE

#### 1. PRECONDITIONING

If DTC Confirmation Procedure has been previously conducted, always perform the following procedure before conducting the next test.

1. Turn ignition switch OFF and wait at least 10 seconds.
2. Turn ignition switch ON.
3. Turn ignition switch OFF and wait at least 10 seconds.

>> GO TO 2.

#### 2. PERFORM DTC CONFIRMATION PROCEDURE

1. Turn ignition switch ON and wait at least 5 seconds.
2. Check DTC.

Is DTC detected?

- YES >> Go to [EC-714, "Diagnosis Procedure"](#).  
NO >> INSPECTION END

### Diagnosis Procedure

INFOID:000000007729807

#### 1. CHECK GROUND CONNECTION

1. Turn ignition switch OFF.
2. Check ground connection M95. Refer to Ground Inspection in [GI-47, "Circuit Inspection"](#).

Is the inspection result normal?

- YES >> GO TO 2.  
NO >> Repair or replace ground connection.

#### 2. CHECK ECT SENSOR POWER SUPPLY CIRCUIT

1. Disconnect engine coolant temperature (ECT) sensor harness connector.
2. Turn ignition switch ON.
3. Check the voltage between ECT sensor harness connector and ground.

| ECT sensor |          | Ground | Voltage (V) |
|------------|----------|--------|-------------|
| Connector  | Terminal |        |             |
| F17        | 1        | Ground | Approx. 5   |

Is the inspection result normal?

- YES >> GO TO 4.  
NO >> GO TO 3.

#### 3. DETECT MALFUNCTIONING PART

Check the following.

- Harness connectors F106, F107
- Harness for open or short between engine coolant temperature sensor and ECM

# P0117, P0118 ECT SENSOR

[VQ37VHR FOR MEXICO]

## < DTC/CIRCUIT DIAGNOSIS >

>> Repair open circuit, short to ground or short to power in harness or connectors.

### 4. CHECK ECT SENSOR GROUND CIRCUIT FOR OPEN AND SHORT

1. Turn ignition switch OFF.
2. Disconnect ECM harness connector.
3. Check the continuity between ECT sensor harness connector and ECM harness connector.

| ECT sensor |          | ECM       |          | Continuity |
|------------|----------|-----------|----------|------------|
| Connector  | Terminal | Connector | Terminal |            |
| F17        | 2        | F102      | 84       | Existed    |

4. Also check harness for short to ground and short to power.

Is the inspection result normal?

YES >> GO TO 5.

NO >> Repair open circuit, short to ground or short to power in harness or connectors.

### 5. CHECK ENGINE COOLANT TEMPERATURE SENSOR

Refer to [EC-715. "Component Inspection"](#).

Is the inspection result normal?

YES >> GO TO 6.

NO >> Replace engine coolant temperature sensor. Refer to [CO-25. "Exploded View"](#).

### 6. CHECK INTERMITTENT INCIDENT

Refer to [GI-44. "Intermittent Incident"](#).

>> INSPECTION END

## Component Inspection

INFOID:000000007729808

### 1. CHECK ENGINE COOLANT TEMPERATURE SENSOR

1. Turn ignition switch OFF.
2. Disconnect engine coolant temperature sensor harness connector.
3. Remove engine coolant temperature sensor. Refer to [CO-25. "Exploded View"](#).
4. Check resistance between engine coolant temperature sensor terminals by heating with hot water as shown in the figure.

| Terminals | Condition           | Resistance (kΩ) |               |
|-----------|---------------------|-----------------|---------------|
| 1 and 2   | Temperature °C (°F) | 20 (68)         | 2.10 - 2.90   |
|           |                     | 50 (122)        | 0.68 - 1.00   |
|           |                     | 90 (194)        | 0.236 - 0.260 |

Is the inspection result normal?

YES >> INSPECTION END

NO >> Replace engine coolant temperature sensor. Refer to [CO-25. "Exploded View"](#).

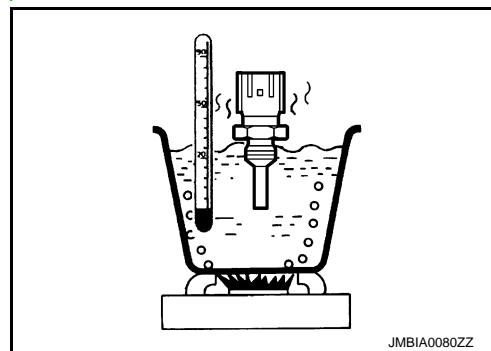

# P0122, P0123, P0227, P0228 TP SENSOR

< DTC/CIRCUIT DIAGNOSIS >

[VQ37VHR FOR MEXICO]

## P0122, P0123, P0227, P0228 TP SENSOR

### DTC Logic

INFOID:000000007729809

#### DTC DETECTION LOGIC

##### NOTE:

If DTC P0122, P0123, P0227 or P0228 is displayed with DTC P0643, first perform the trouble diagnosis for DTC P0643. Refer to [EC-822, "DTC Logic"](#).

| DTC No. | Trouble diagnosis name                                 | DTC detecting condition  | Possible cause   |
|---------|--|--|--|
| P0122   | Throttle position sensor 2 (bank 1) circuit low input  | An excessively low voltage from the TP sensor 2 is sent to ECM.  | <ul style="list-style-type: none"><li>• Harness or connectors (TP sensor 2 circuit is open or shorted.)</li><li>• Electric throttle control actuator (TP sensor 2)</li></ul> |
| P0123   | Throttle position sensor 2 (bank 1) circuit high input | An excessively high voltage from the TP sensor 2 is sent to ECM. |  |
| P0227   | Throttle position sensor 2 (bank 2) circuit low input  | An excessively low voltage from the TP sensor 2 is sent to ECM.  |  |
| P0228   | Throttle position sensor 2 (bank 2) circuit high input | An excessively high voltage from the TP sensor 2 is sent to ECM. |  |

#### DTC CONFIRMATION PROCEDURE

##### 1. PRECONDITIONING

If DTC Confirmation Procedure has been previously conducted, always perform the following procedure before conducting the next test.

1. Turn ignition switch OFF and wait at least 10 seconds.
2. Turn ignition switch ON.
3. Turn ignition switch OFF and wait at least 10 seconds.

##### TESTING CONDITION:

Before performing the following procedure, confirm that battery voltage is more than 10 V at idle.

>> GO TO 2.

##### 2. PERFORM DTC CONFIRMATION PROCEDURE

1. Start engine and let it idle for 1 second.
2. Check DTC.

Is DTC detected?

YES >> Go to [EC-716, "Diagnosis Procedure"](#).

NO >> INSPECTION END

#### Diagnosis Procedure

INFOID:000000007729810

##### 1. CHECK GROUND CONNECTION

1. Turn ignition switch OFF.
2. Check ground connection M95. Refer to Ground Inspection in [GI-47, "Circuit Inspection"](#).

Is the inspection result normal?

YES >> GO TO 2.

NO >> Repair or replace ground connection.

##### 2. CHECK THROTTLE POSITION SENSOR 2 POWER SUPPLY CIRCUIT

1. Disconnect electric throttle control actuator harness connector.
2. Turn ignition switch ON.
3. Check the voltage between electric throttle control actuator harness connector and ground.

# P0122, P0123, P0227, P0228 TP SENSOR

< DTC/CIRCUIT DIAGNOSIS >

[VQ37VHR FOR MEXICO]

| DTC          | Electric throttle control actuator |           |          | Ground | Voltage (V) |
|--------------|------------------------------------|-----------|----------|--------|-------------|
|              | Bank                               | Connector | Terminal |        |             |
| P0122, P0123 | 1                                  | F67       | 6        | Ground | Approx. 5   |
| P0227, P0228 | 2                                  | F27       | 1        |        |             |

Is the inspection result normal?

YES >> GO TO 3.

NO >> Repair open circuit, short to ground or short to power in harness or connectors.

## 3. CHECK THROTTLE POSITION SENSOR 2 GROUND CIRCUIT FOR OPEN AND SHORT

1. Turn ignition switch OFF.
2. Disconnect ECM harness connector.
3. Check the continuity between electric throttle control actuator harness connector and ECM harness connector.

| DTC          | Electric throttle control actuator |           |          | ECM       |          | Continuity |
|--------------|------------------------------------|-----------|----------|-----------|----------|------------|
|              | Bank                               | Connector | Terminal | Connector | Terminal |            |
| P0122, P0123 | 1                                  | F67       | 3        | F101      | 40       | Existed    |
| P0227, P0228 | 2                                  | F27       | 4        |           | 48       |            |

4. Also check harness for short to ground and short to power.

Is the inspection result normal?

YES >> GO TO 4.

NO >> Repair open circuit, short to ground or short to power in harness or connectors.

## 4. CHECK THROTTLE POSITION SENSOR 2 INPUT SIGNAL CIRCUIT FOR OPEN AND SHORT

1. Check the continuity between electric throttle control actuator harness connector and ECM harness connector.

| DTC          | Electric throttle control actuator |           |          | ECM       |          | Continuity |
|--------------|------------------------------------|-----------|----------|-----------|----------|------------|
|              | Bank                               | Connector | Terminal | Connector | Terminal |            |
| P0122, P0123 | 1                                  | F67       | 5        | F101      | 34       | Existed    |
| P0227, P0228 | 2                                  | F27       | 3        |           | 35       |            |

2. Also check harness for short to ground and short to power.

Is the inspection result normal?

YES >> GO TO 5.

NO >> Repair open circuit, short to ground or short to power in harness or connectors.

## 5. CHECK THROTTLE POSITION SENSOR

Refer to [EC-718, "Component Inspection"](#).

Is the inspection result normal?

YES >> GO TO 7.

NO >> GO TO 6.

## 6. REPLACE ELECTRIC THROTTLE CONTROL ACTUATOR

1. Replace malfunctioning electric throttle control actuator.
2. Go to [EC-718, "Special Repair Requirement"](#).

>> INSPECTION END

## 7. CHECK INTERMITTENT INCIDENT

Refer to [GI-44, "Intermittent Incident"](#).

>> INSPECTION END

# P0122, P0123, P0227, P0228 TP SENSOR

< DTC/CIRCUIT DIAGNOSIS >

[VQ37VHR FOR MEXICO]

INFOID:000000007729811

## Component Inspection

### 1. CHECK THROTTLE POSITION SENSOR

1. Turn ignition switch OFF.
2. Reconnect all harness connectors disconnected.
3. Perform [EC-657, "Work Procedure"](#).
4. Turn ignition switch ON.
5. Set selector lever to D position.
6. Check the voltage between ECM harness connector terminals under the following conditions.

| ECM       |                           |          | Condition       | Voltage (V)    |
|-----------|---------------------------|----------|-----------------|----------------|
| Connector | +                         | -        |                 |                |
|           | Terminal                  | Terminal |                 |                |
| F101      | 30 [TP sensor 1 (bank 1)] | 40       | Fully released  | More than 0.36 |
|           |                           |          | Fully depressed | Less than 4.75 |
|           | 31 [TP sensor 1 (bank 2)] | 48       | Fully released  | More than 0.36 |
|           |                           |          | Fully depressed | Less than 4.75 |
|           | 34 [TP sensor 2 (bank 1)] | 40       | Fully released  | Less than 4.75 |
|           |                           |          | Fully depressed | More than 0.36 |
|           | 35 [TP sensor 2 (bank 2)] | 48       | Fully released  | Less than 4.75 |
|           |                           |          | Fully depressed | More than 0.36 |

Is the inspection result normal?

YES >> INSPECTION END

NO >> GO TO 2.

### 2. REPLACE ELECTRIC THROTTLE CONTROL ACTUATOR

1. Replace malfunctioning electric throttle control actuator.
2. Go to [EC-718, "Special Repair Requirement"](#).

>> INSPECTION END

## Special Repair Requirement

INFOID:000000007729812

### 1. PERFORM THROTTLE VALVE CLOSED POSITION LEARNING

Refer to [EC-657, "Work Procedure"](#)

>> GO TO 2.

### 2. PERFORM IDLE AIR VOLUME LEARNING

Refer to [EC-658, "Work Procedure"](#)

>> END

P0130, P0150 A/F SENSOR 1

DTC Logic

INFOID:000000007729825

DTC DETECTION LOGIC

To judge malfunctions, the diagnosis checks that the A/F signal computed by ECM from the A/F sensor 1 signal fluctuates according to fuel feedback control.

| DTC No. | Trouble diagnosis name                         | DTC detecting condition |  | Possible Cause   |
|---------|--|-------------------------|--|--|
| P0130   | Air fuel ratio (A/F) sensor 1 (bank 1) circuit | A)                      | The A/F signal computed by ECM from the A/F sensor 1 signal is constantly in a range other than approx. 2.2 V. | <ul style="list-style-type: none"> <li>• Harness or connectors (The A/F sensor 1 circuit is open or shorted.)</li> <li>• A/F sensor 1</li> </ul> |
|         |  | B)                      | The A/F signal computed by ECM from the A/F sensor 1 signal is constantly approx. 2.2 V.                       |  |
| P0150   | Air fuel ratio (A/F) sensor 1 (bank 2) circuit | A)                      | The A/F signal computed by ECM from the A/F sensor 1 signal is constantly in a range other than approx. 2.2 V. |  |
|         |  | B)                      | The A/F signal computed by ECM from the A/F sensor 1 signal is constantly approx. 2.2 V.                       |  |

DTC CONFIRMATION PROCEDURE

1. PRECONDITIONING

If DTC Confirmation Procedure has been previously conducted, always perform the following procedure before conducting the next test.

1. Turn ignition switch OFF and wait at least 10 seconds.
2. Turn ignition switch ON.
3. Turn ignition switch OFF and wait at least 10 seconds.

**TESTING CONDITION:**

**Before performing the following procedure, confirm that battery voltage is more than 11 V at idle.**

>> GO TO 2.

2. PERFORM DTC CONFIRMATION PROCEDURE FOR MALFUNCTION A

1. Start engine and warm it up to normal operating temperature.
2. Let engine idle for 2 minutes.
3. Check 1st trip DTC.

Is 1st trip DTC detected?

YES >> Go to [EC-721, "Diagnosis Procedure"](#).

NO-1 >> With CONSULT: GO TO 3.

NO-2 >> Without CONSULT: GO TO 7.

3. CHECK AIR FUEL RATIO (A/F) SENSOR 1 FUNCTION

1. Start engine and warm it up to normal operating temperature.
2. Select "A/F SEN1 (B1)" or "A/F SEN1 (B2)" in "DATA MONITOR" mode with CONSULT.
3. Check "A/F SEN1 (B1)" or "A/F SEN1 (B2)" indication.

Does the indication fluctuate around 2.2 V?

YES >> GO TO 4.

NO >> Go to [EC-721, "Diagnosis Procedure"](#).

4. PERFORM DTC CONFIRMATION PROCEDURE FOR MALFUNCTION B-I

1. Select "A/F SEN1 (B1) P1276" (for DTC P0130) or "A/F SEN1 (B2) P1286" (for DTC P0150) of "A/F SEN1" in "DTC WORK SUPPORT" mode with CONSULT.
2. Touch "START".
3. When the following conditions are met, "TESTING" will be displayed on the CONSULT screen.

# P0130, P0150 A/F SENSOR 1

< DTC/CIRCUIT DIAGNOSIS >

[VQ37VHR FOR MEXICO]

|                |                            |
|----------------|----------------------------|
| ENG SPEED      | 1,100 - 3,200 rpm          |
| VHCL SPEED SE  | More than 64 km/h (40 mph) |
| B/FUEL SCHDL   | 1.0 - 8.0 msec             |
| Selector lever | D position                 |

If "TESTING" is not displayed after 20 seconds, retry from step 2.

**CAUTION:**

**Always drive vehicle at a safe speed.**

Is "TESTING" displayed on CONSULT screen?

YES >> GO TO 5.

NO >> Check A/F sensor 1 function again. GO TO 3.

## 5. PERFORM DTC CONFIRMATION PROCEDURE FOR MALFUNCTION B-II

Release accelerator pedal fully.

**NOTE:**

Never apply brake when releasing the accelerator pedal.

Which does "TESTING" change to?

COMPLETED>>GO TO 6.

OUT OF CONDITION>>Retry DTC CONFIRMATION PROCEDURE. GO TO 4.

## 6. PERFORM DTC CONFIRMATION PROCEDURE FOR MALFUNCTION B-III

Touch "SELF-DIAG RESULT".

Which is displayed on CONSULT screen?

OK >> INSPECTION END

NG >> Go to [EC-721, "Diagnosis Procedure"](#).

## 7. PERFORM COMPONENT FUNCTION CHECK FOR MALFUNCTION B

Perform component function check. Refer to [EC-720, "Component Function Check"](#).

**NOTE:**

Use component function check to check the overall function of the A/F sensor 1 circuit. During this check, a 1st trip DTC might not be confirmed.

Is the inspection result normal?

YES >> INSPECTION END

NO >> Go to [EC-721, "Diagnosis Procedure"](#).

## Component Function Check

INFOID:000000007729826

### 1. PERFORM COMPONENT FUNCTION CHECK

 **With GST**

1. Start engine and warm it up to normal operating temperature.
2. Drive the vehicle at a speed of 80 km/h (50 MPH) for a few minutes in the suitable gear position.
3. Shift the selector lever to D position, then release the accelerator pedal fully until the vehicle speed decreases to 50 km/h (30 MPH).

**CAUTION:**

**Always drive vehicle at a safe speed.**

**NOTE:**

Never apply brake when releasing the accelerator pedal.

4. Repeat steps 2 and 3 for five times.
5. Stop the vehicle and turn ignition switch OFF.
6. Turn ignition switch ON.
7. Turn ignition switch OFF and wait at least 10 seconds.
8. Restart engine.
9. Repeat steps 2 and 3 for five times.
10. Stop the vehicle and connect GST to the vehicle.
11. Check 1st trip DTC.

Is 1st trip DTC detected?



# P0130, P0150 A/F SENSOR 1

[VQ37VHR FOR MEXICO]

## < DTC/CIRCUIT DIAGNOSIS >

- YES >> Go to [EC-721, "Diagnosis Procedure"](#).  
NO >> INSPECTION END

## Diagnosis Procedure

INFOID:000000007729827

### 1. CHECK GROUND CONNECTION

1. Turn ignition switch OFF.
2. Check ground connection M95. Refer to Ground Inspection in [GI-47, "Circuit Inspection"](#).

Is the inspection result normal?

- YES >> GO TO 2.  
NO >> Repair or replace ground connection.

### 2. CHECK AIR FUEL RATIO (A/F) SENSOR 1 POWER SUPPLY CIRCUIT

1. Disconnect A/F sensor 1 harness connector.
2. Turn ignition switch ON.
3. Check the voltage between A/F sensor 1 harness connector and ground.

| DTC   | A/F sensor 1 |           |          | Ground | Voltage         |
|-------|--------------|-----------|----------|--------|-----------------|
|       | Bank         | Connector | Terminal |        |                 |
| P0130 | 1            | F74       | 4        | Ground | Battery voltage |
| P0150 | 2            | F75       | 4        |        |                 |

Is the inspection result normal?

- YES >> GO TO 4.  
NO >> GO TO 3.

### 3. DETECT MALFUNCTIONING PART

Check the following.

- Harness connectors E20, F40
- IPDM E/R harness connector E7
- 15 A fuse (No. 45)
- Harness for open or short between A/F sensor 1 and fuse

>> Repair or replace harness or connectors.

### 4. CHECK A/F SENSOR 1 INPUT SIGNAL CIRCUIT FOR OPEN AND SHORT

1. Turn ignition switch OFF.
2. Disconnect ECM harness connector.
3. Check the continuity between A/F sensor 1 harness connector and ECM harness connector.

| DTC   | A/F sensor 1 |           |          | ECM       |          | Continuity |
|-------|--------------|-----------|----------|-----------|----------|------------|
|       | Bank         | Connector | Terminal | Connector | Terminal |            |
| P0130 | 1            | F74       | 1        | F102      | 57       | Existed    |
|       |              |           | 2        |           | 61       |            |
| P0150 | 2            | F75       | 1        |           | 65       |            |
|       |              |           | 2        |           | 66       |            |

4. Check the continuity between A/F sensor 1 harness connector and ground, or ECM harness connector and ground.

# P0130, P0150 A/F SENSOR 1

< DTC/CIRCUIT DIAGNOSIS >

[VQ37VHR FOR MEXICO]

| DTC   | A/F sensor 1 |           |          | Ground | Continuity  |
|-------|--------------|-----------|----------|--------|-------------|
|       | Bank         | Connector | Terminal |        |             |
| P0130 | 1            | F74       | 1        | Ground | Not existed |
|       |              |           | 2        |        |             |
| P0150 | 2            | F75       | 1        |        |             |
|       |              |           | 2        |        |             |

| DTC   | ECM  |           |          | Ground | Continuity  |
|-------|------|-----------|----------|--------|-------------|
|       | Bank | Connector | Terminal |        |             |
| P0130 | 1    | F102      | 57       | Ground | Not existed |
|       |      |           | 61       |        |             |
| P0150 | 2    |           | 65       |        |             |
|       |      |           | 66       |        |             |

5. Also check harness for short to power.

Is the inspection result normal?

YES >> GO TO 5.

NO >> Repair open circuit, short to ground or short to power in harness or connectors.

## 5.CHECK INTERMITTENT INCIDENT

Perform [GI-44, "Intermittent Incident"](#).

Is the inspection result normal?

YES >> GO TO 6.

NO >> Repair or replace.

## 6.REPLACE AIR FUEL RATIO (A/F) SENSOR 1

Replace malfunctioning air fuel ratio (A/F) sensor 1.

### CAUTION:

- Discard any A/F sensor which has been dropped from a height of more than 0.5 m (19.7 in) onto a hard surface such as a concrete floor; use a new one.
- Before installing new A/F sensor, clean exhaust system threads using Oxygen Sensor Thread Cleaner [commercial service tool (J-43897-18 or J-43897-12)] and approved anti-seize Lubricant (commercial service tool).

>> INSPECTION END

# P0131, P0151 A/F SENSOR 1

< DTC/CIRCUIT DIAGNOSIS >

[VQ37VHR FOR MEXICO]

## P0131, P0151 A/F SENSOR 1

### DTC Logic

INFOID:000000007729828

#### DTC DETECTION LOGIC

To judge malfunctions, the diagnosis checks that the A/F signal computed by ECM from the A/F sensor 1 signal is not inordinately low.

| DTC No. | Trouble diagnosis name                                     | DTC detecting condition  | Possible Cause   |
|---------|--|--|--|
| P0131   | Air fuel ratio (A/F) sensor 1 (bank 1) circuit low voltage | • The A/F signal computed by ECM from the A/F sensor 1 signal is constantly approx. 0 V. | • Harness or connectors (The A/F sensor 1 circuit is open or shorted.)<br>• A/F sensor 1 |
| P0151   | Air fuel ratio (A/F) sensor 1 (bank 2) circuit low voltage |  |  |

#### DTC CONFIRMATION PROCEDURE

##### 1. PRECONDITIONING

If DTC Confirmation Procedure has been previously conducted, always perform the following procedure before conducting the next test.

1. Turn ignition switch OFF and wait at least 10 seconds.
2. Turn ignition switch ON.
3. Turn ignition switch OFF and wait at least 10 seconds.

##### TESTING CONDITION:

**Before performing the following procedure, confirm that battery voltage is more than 10.5 V at idle.**

>> GO TO 2.

##### 2. CHECK A/F SENSOR FUNCTION

1. Start engine and warm it up to normal operating temperature.
2. Select "A/F SEN1 (B1)" or "A/F SEN1 (B2)" in "DATA MONITOR" mode with CONSULT
3. Check "A/F SEN1 (B1)" or "A/F SEN1 (B2)" indication.

Is the indication constantly approx. 0 V?

YES >> Go to [EC-724, "Diagnosis Procedure"](#).

NO >> GO TO 3.

##### 3. PERFORM DTC CONFIRMATION PROCEDURE

1. Turn ignition switch OFF and wait at least 10 seconds.
2. Turn ignition switch ON.
3. Turn ignition switch OFF and wait at least 10 seconds.
4. Restart engine.
5. Drive and accelerate vehicle to more than 40 km/h (25 MPH) within 20 seconds after restarting engine.

##### CAUTION:

**Always drive vehicle at a safe speed.**

6. Maintain the following conditions for about 20 consecutive seconds.

|                |                            |
|----------------|----------------------------|
| ENG SPEED      | 1,000 - 3,200 rpm          |
| VHCL SPEED SE  | More than 40 km/h (25 mph) |
| B/FUEL SCHDL   | 1.5 - 9.0 msec             |
| Selector lever | Suitable position          |

##### NOTE:

- Keep the accelerator pedal as steady as possible during cruising.
- If this procedure is not completed within 1 minute after restarting engine at step 4, return to step 1.

7. Check 1st trip DTC.

Is 1st trip DTC detected?

YES >> Go to [EC-724, "Diagnosis Procedure"](#).

NO >> INSPECTION END

# P0131, P0151 A/F SENSOR 1

< DTC/CIRCUIT DIAGNOSIS >

[VQ37VHR FOR MEXICO]

INFOID:000000007729829

## Diagnosis Procedure

### 1. CHECK GROUND CONNECTION

1. Turn ignition switch OFF.
2. Check ground connection M95. Refer to Ground Inspection in [GI-47. "Circuit Inspection"](#).

Is the inspection result normal?

- YES >> GO TO 2.  
NO >> Repair or replace ground connection.

### 2. CHECK AIR FUEL RATIO (A/F) SENSOR 1 POWER SUPPLY CIRCUIT

1. Disconnect A/F sensor 1 harness connector.
2. Turn ignition switch ON.
3. Check the voltage between A/F sensor 1 harness connector and ground.

| DTC   | A/F sensor 1 |           |          | Ground | Voltage         |
|-------|--------------|-----------|----------|--------|-----------------|
|       | Bank         | Connector | Terminal |        |                 |
| P0130 | 1            | F74       | 4        | Ground | Battery voltage |
| P0150 | 2            | F75       | 4        |        |                 |

Is the inspection result normal?

- YES >> GO TO 4.  
NO >> GO TO 3.

### 3. DETECT MALFUNCTIONING PART

Check the following.

- Harness connectors E20, F40
- IPDM E/R harness connector E7
- 15 A fuse (No. 45)
- Harness for open or short between A/F sensor 1 and fuse

>> Repair or replace harness or connectors.

### 4. CHECK A/F SENSOR 1 INPUT SIGNAL CIRCUIT FOR OPEN AND SHORT

1. Turn ignition switch OFF.
2. Disconnect ECM harness connector.
3. Check the continuity between A/F sensor 1 harness connector and ECM harness connector.

| DTC   | A/F sensor 1 |           |          | ECM       |          | Continuity |
|-------|--------------|-----------|----------|-----------|----------|------------|
|       | Bank         | Connector | Terminal | Connector | Terminal |            |
| P0130 | 1            | F74       | 1        | F102      | 57       | Existed    |
|       |              |           | 2        |           | 61       |            |
| P0150 | 2            | F75       | 1        |           | 65       |            |
|       |              |           | 2        |           | 66       |            |

4. Check the continuity between A/F sensor 1 harness connector and ground, or ECM harness connector and ground.

| DTC   | A/F sensor 1 |           |          | Ground | Continuity  |
|-------|--------------|-----------|----------|--------|-------------|
|       | Bank         | Connector | Terminal |        |             |
| P0130 | 1            | F74       | 1        | Ground | Not existed |
|       |              |           | 2        |        |             |
| P0150 | 2            | F75       | 1        |        |             |
|       |              |           | 2        |        |             |

# P0131, P0151 A/F SENSOR 1

< DTC/CIRCUIT DIAGNOSIS >

[VQ37VHR FOR MEXICO]

| DTC   | ECM  |           |          | Ground | Continuity  |
|-------|------|-----------|----------|--------|-------------|
|       | Bank | Connector | Terminal |        |             |
| P0130 | 1    | F102      | 57       | Ground | Not existed |
|       |      |           | 61       |        |             |
| P0150 | 2    |           | 65       |        |             |
|       |      |           | 66       |        |             |

5. Also check harness for short to power.

Is the inspection result normal?

YES >> GO TO 5.

NO >> Repair open circuit, short to ground or short to power in harness or connectors.

## 5.CHECK INTERMITTENT INCIDENT

Perform [GI-44. "Intermittent Incident"](#).

Is the inspection result normal?

YES >> GO TO 6.

NO >> Repair or replace.

## 6.REPLACE AIR FUEL RATIO (A/F) SENSOR 1

Replace malfunctioning air fuel ratio (A/F) sensor 1.

### CAUTION:

- Discard any A/F sensor which has been dropped from a height of more than 0.5 m (19.7 in) onto a hard surface such as a concrete floor; use a new one.
- Before installing new A/F sensor, clean exhaust system threads using Oxygen Sensor Thread Cleaner [commercial service tool (J-43897-18 or J-43897-12)] and approved anti-seize Lubricant (commercial service tool).

>> INSPECTION END

A  
EC  
C  
D  
E  
F  
G  
H  
I  
J  
K  
L  
M  
N  
O  
P

# P0132, P0152 A/F SENSOR 1

< DTC/CIRCUIT DIAGNOSIS >

[VQ37VHR FOR MEXICO]

## P0132, P0152 A/F SENSOR 1

### DTC Logic

INFOID:000000007729830

#### DTC DETECTION LOGIC

To judge the malfunction, the diagnosis checks that the A/F signal computed by ECM from the A/F sensor 1 signal is not inordinately high.

| DTC No. | Trouble diagnosis name                                      | DTC detecting condition  | Possible Cause   |
|---------|---|--|--|
| P0132   | Air fuel ratio (A/F) sensor 1 (bank 1) circuit high voltage | • The A/F signal computed by ECM from the A/F sensor 1 signal is constantly approx. 5 V. | • Harness or connectors (The A/F sensor 1 circuit is open or shorted.)<br>• A/F sensor 1 |
| P0152   | Air fuel ratio (A/F) sensor 1 (bank 2) circuit high voltage |  |  |

#### DTC CONFIRMATION PROCEDURE

##### 1. PRECONDITIONING

If DTC Confirmation Procedure has been previously conducted, always perform the following procedure before conducting the next test.

1. Turn ignition switch OFF and wait at least 10 seconds.
2. Turn ignition switch ON.
3. Turn ignition switch OFF and wait at least 10 seconds.

##### TESTING CONDITION:

**Before performing the following procedure, confirm that battery voltage is more than 10.5 V at idle.**

>> GO TO 2.

##### 2. CHECK A/F SENSOR FUNCTION

1. Start engine and warm it up to normal operating temperature.
2. Select "A/F SEN1 (B1)" or "A/F SEN1 (B2)" in "DATA MONITOR" mode with CONSULT.
3. Check "A/F SEN1 (B1)" or "A/F SEN1 (B2)" indication.

Is the indication constantly approx. 5V?

YES >> Go to [EC-727, "Diagnosis Procedure"](#).

NO >> GO TO 3.

##### 3. PERFORM DTC CONFIRMATION PROCEDURE

1. Turn ignition switch OFF and wait at least 10 seconds.
2. Turn ignition switch ON.
3. Turn ignition switch OFF and wait at least 10 seconds.
4. Restart engine.
5. Drive and accelerate vehicle to more than 40 km/h (25 MPH) within 20 seconds after restarting engine.

##### CAUTION:

**Always drive vehicle at a safe speed.**

6. Maintain the following conditions for about 20 consecutive seconds.

|                |                            |
|----------------|----------------------------|
| ENG SPEED      | 1,000 - 3,200 rpm          |
| VHCL SPEED SE  | More than 40 km/h (25 mph) |
| B/FUEL SCHDL   | 1.5 - 9.0 msec             |
| Selector lever | Suitable position          |

##### NOTE:

- Keep the accelerator pedal as steady as possible during cruising.
- If this procedure is not completed within 1 minute after restarting engine at step 4, return to step 1.

7. Check 1st trip DTC.

Is 1st trip DTC detected?

YES >> Go to [EC-727, "Diagnosis Procedure"](#).

NO >> INSPECTION END

Diagnosis Procedure

1. CHECK GROUND CONNECTION

1. Turn ignition switch OFF.
2. Check ground connection M95. Refer to Ground Inspection in [GI-47. "Circuit Inspection"](#).

Is the inspection result normal?

- YES >> GO TO 2.  
 NO >> Repair or replace ground connection.

2. CHECK AIR FUEL RATIO (A/F) SENSOR 1 POWER SUPPLY CIRCUIT

1. Disconnect A/F sensor 1 harness connector.
2. Turn ignition switch ON.
3. Check the voltage between A/F sensor 1 harness connector and ground.

| DTC   | A/F sensor 1 |           |          | Ground | Voltage         |
|-------|--------------|-----------|----------|--------|-----------------|
|       | Bank         | Connector | Terminal |        |                 |
| P0130 | 1            | F74       | 4        | Ground | Battery voltage |
| P0150 | 2            | F75       | 4        |        |                 |

Is the inspection result normal?

- YES >> GO TO 4.  
 NO >> GO TO 3.

3. DETECT MALFUNCTIONING PART

Check the following.

- Harness connectors E20, F40
- IPDM E/R harness connector E7
- 15 A fuse (No. 45)
- Harness for open or short between A/F sensor 1 and fuse

>> Repair or replace harness or connectors.

4. CHECK A/F SENSOR 1 INPUT SIGNAL CIRCUIT FOR OPEN AND SHORT

1. Turn ignition switch OFF.
2. Disconnect ECM harness connector.
3. Check the continuity between A/F sensor 1 harness connector and ECM harness connector.

| DTC   | A/F sensor 1 |           |          | ECM       |          | Continuity |
|-------|--------------|-----------|----------|-----------|----------|------------|
|       | Bank         | Connector | Terminal | Connector | Terminal |            |
| P0130 | 1            | F74       | 1        | F102      | 57       | Existed    |
|       |              |           | 2        |           | 61       |            |
| P0150 | 2            | F75       | 1        |           | 65       |            |
|       |              |           | 2        |           | 66       |            |

4. Check the continuity between A/F sensor 1 harness connector and ground, or ECM harness connector and ground.

| DTC   | A/F sensor 1 |           |          | Ground | Continuity  |
|-------|--------------|-----------|----------|--------|-------------|
|       | Bank         | Connector | Terminal |        |             |
| P0130 | 1            | F74       | 1        | Ground | Not existed |
|       |              |           | 2        |        |             |
| P0150 | 2            | F75       | 1        |        |             |
|       |              |           | 2        |        |             |

# P0132, P0152 A/F SENSOR 1

< DTC/CIRCUIT DIAGNOSIS >

[VQ37VHR FOR MEXICO]

| DTC   | ECM  |           |          | Ground | Continuity  |
|-------|------|-----------|----------|--------|-------------|
|       | Bank | Connector | Terminal |        |             |
| P0130 | 1    | F102      | 57       | Ground | Not existed |
|       |      |           | 61       |        |             |
| P0150 | 2    |           | 65       |        |             |
|       |      |           | 66       |        |             |

5. Also check harness for short to power.

Is the inspection result normal?

YES >> GO TO 5.

NO >> Repair open circuit, short to ground or short to power in harness or connectors.

## 5.CHECK INTERMITTENT INCIDENT

Perform [GI-44. "Intermittent Incident"](#).

Is the inspection result normal?

YES >> GO TO 6.

NO >> Repair or replace.

## 6.REPLACE AIR FUEL RATIO (A/F) SENSOR 1

Replace malfunctioning air fuel ratio (A/F) sensor 1.

### **CAUTION:**

- Discard any A/F sensor which has been dropped from a height of more than 0.5 m (19.7 in) onto a hard surface such as a concrete floor; use a new one.
- Before installing new A/F sensor, clean exhaust system threads using Oxygen Sensor Thread Cleaner [commercial service tool (J-43897-18 or J-43897-12)] and approved anti-seize Lubricant (commercial service tool).

>> INSPECTION END



P0133, P0153 A/F SENSOR 1

DTC Logic

INFOID:000000007729832

DTC DETECTION LOGIC

To judge malfunctions, this diagnosis measures response time of the A/F signal computed by ECM from the A/F sensor 1 signal. The time is compensated by engine operating (speed and load), fuel feedback control constant, and the A/F sensor 1 temperature index. Judgment is based on whether the compensated time (the A/F signal cycling time index) is inordinately long or not.

| DTC No. | Trouble diagnosis name                                       | DTC detecting condition   | Possible Cause  |
|---------|--|---|---|
| P0133   | Air fuel ratio (A/F) sensor 1 (bank 1) circuit slow response | <ul style="list-style-type: none"> <li>The response of the A/F signal computed by ECM from A/F sensor 1 signal takes more than the specified time.</li> </ul> | <ul style="list-style-type: none"> <li>Harness or connectors (The A/F sensor 1 circuit is open or shorted.)</li> <li>A/F sensor 1</li> <li>A/F sensor 1 heater</li> <li>Fuel pressure</li> <li>Fuel injector</li> <li>Intake air leaks</li> <li>Exhaust gas leaks</li> <li>PCV</li> <li>Mass air flow sensor</li> </ul> |
| P0153   | Air fuel ratio (A/F) sensor 1 (bank 2) circuit slow response |   |   |

DTC CONFIRMATION PROCEDURE

1. PRECONDITIONING

If DTC Confirmation Procedure has been previously conducted, always perform the following procedure before conducting the next test.

- Turn ignition switch OFF and wait at least 10 seconds.
- Turn ignition switch ON.
- Turn ignition switch OFF and wait at least 10 seconds.

**TESTING CONDITION:**

**Before performing the following procedure, confirm that battery voltage is more than 11 V at idle.**

Do you have CONSULT?

- YES >> GO TO 2.
- NO >> GO TO 5.

2. PERFORM DTC CONFIRMATION PROCEDURE-I

 **With CONSULT**

- Start engine and warm it up to normal operating temperature.
- Turn ignition switch OFF and wait at least 10 seconds.
- Turn ignition switch ON.
- Turn ignition switch OFF and wait at least 10 seconds.
- Start engine and keep the engine speed between 3,500 and 4,000 rpm for at least 1 minute under no load.
- Let engine idle for 1 minute.
- Select "A/F SEN1(B1) P1278/P1279" (for DTC P0133) or "A/F SEN1(B2) P1288/P1289" (for DTC P0153) of "A/F SEN1" in "DTC WORK SUPPORT" mode with CONSULT.
- Touch "START".

Is "COMPLETED" displayed on CONSULT screen?

- YES >> GO TO 3
- NO >> GO TO 4.

3. PERFORM DTC CONFIRMATION PROCEDURE-II

Touch "SELF-DIAG RESULT".

Which is displayed on CONSULT screen?

- OK >> INSPECTION END
- NG >> Go to [EC-730, "Diagnosis Procedure"](#).

4. PERFORM DTC CONFIRMATION PROCEDURE-II

- After perform the following procedure, "TESTING" will be displayed on the CONSULT screen.

# P0133, P0153 A/F SENSOR 1

[VQ37VHR FOR MEXICO]

## < DTC/CIRCUIT DIAGNOSIS >

- Increase the engine speed up to about 3,600 rpm and maintain that speed for 10 seconds.
  - Fully release accelerator pedal and then let engine idle for about 10 seconds.
- If **"TESTING"** is not displayed after 10 seconds, go to [EC-674, "Component Function Check"](#).
2. Wait for about 20 seconds at idle under the condition that "TESTING" is displayed on the CONSULT screen.
  3. Make sure that "TESTING" changes to "COMPLETED".  
If **"TESTING"** changed to **"OUT OF CONDITION"**, go to [EC-674, "Component Function Check"](#).
  4. Touch "SELF-DIAG RESULT".

Which is displayed on CONSULT screen?

- OK >> INSPECTION END
- NG >> Go to [EC-730, "Diagnosis Procedure"](#).

## 5. CHECK AIR-FUEL RATIO SELF-LEARNING VALUE

### With GST

1. Start engine and warm it up to normal operating temperature.
2. Select Service \$01 with GST.
3. Calculate the total value of "Short term fuel trim" and "Long term fuel trim" indications.

Is the total percentage within  $\pm 15\%$ ?

- YES >> GO TO 7.
- NO >> GO TO 6.

## 6. DETECT MALFUNCTIONING PART

Check the following.

- Intake air leaks
- Exhaust gas leaks
- Incorrect fuel pressure
- Lack of fuel
- Fuel injector
- Incorrect PCV hose connection
- PCV valve
- Mass air flow sensor

>> Repair or replace malfunctioning part.

## 7. PERFORM DTC CONFIRMATION PROCEDURE

1. Turn ignition switch OFF and wait at least 10 seconds.
2. Turn ignition switch ON.
3. Turn ignition switch OFF and wait at least 10 seconds.
4. Start engine and keep the engine speed between 3,500 and 4,000 rpm for at least 1 minute under no load.
5. Let engine idle for 1 minute.
6. Increase the engine speed up to about 3,600 rpm and keep it for 10 seconds.
7. Fully release accelerator pedal and then let engine idle for about 1 minute.
8. Check 1st trip DTC.

Is 1st trip DTC detected?

- YES >> Go to [EC-730, "Diagnosis Procedure"](#).
- NO >> INSPECTION END

## Diagnosis Procedure

INFOID:000000007729833

### 1. CHECK GROUND CONNECTION

1. Turn ignition switch OFF.
2. Check ground connection M95. Refer to Ground Inspection in [GI-47, "Circuit Inspection"](#).

Is the inspection result normal?

- YES >> GO TO 2.
- NO >> Repair or replace ground connection.

### 2. RETIGHTEN A/F SENSOR 1

Loosen and retighten the A/F sensor 1. Refer to [EM-36, "Removal and Installation"](#).

>> GO TO 3.

### 3. CHECK EXHAUST GAS LEAK

1. Start engine and run it at idle.
2. Listen for an exhaust gas leak before three way catalyst 1.

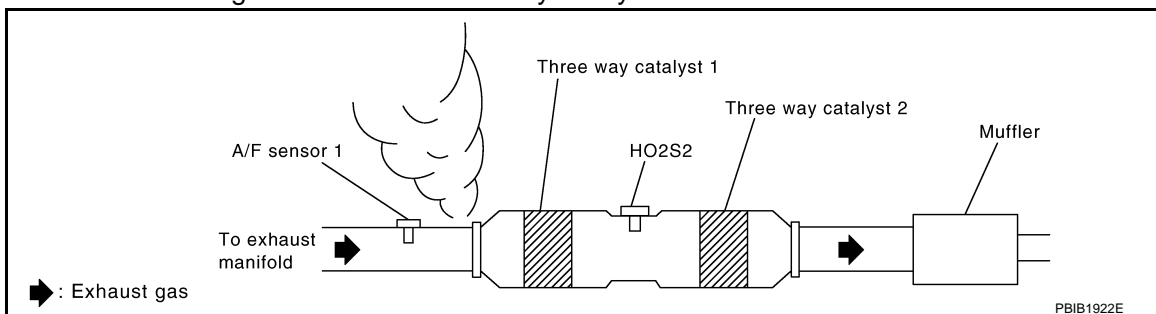

Is exhaust gas leak detected?

- YES >> Repair or replace.  
 NO >> GO TO 4.

### 4. CHECK FOR INTAKE AIR LEAK

Listen for an intake air leak after the mass air flow sensor.

Is intake air leak detected?

- YES >> Repair or replace.  
 NO >> GO TO 5.

### 5. CLEAR THE MIXTURE RATIO SELF-LEARNING VALUE

1. Clear the mixture ratio self-learning value. Refer to [EC-662. "Work Procedure"](#).
2. Run engine for at least 10 minutes at idle speed.

Is the 1st trip DTC P0171, P172, P0174 or P0175 detected? Is it difficult to start engine?

- YES >> Perform trouble diagnosis for DTC P0171, P0174 or P0172, P0175. Refer to [EC-754. "DTC Logic"](#) or [EC-758. "DTC Logic"](#).  
 NO >> GO TO 6.

### 6. CHECK AIR FUEL RATIO (A/F) SENSOR 1 POWER SUPPLY CIRCUIT

1. Disconnect A/F sensor 1 harness connector.
2. Turn ignition switch ON.
3. Check the voltage between A/F sensor 1 harness connector and ground.

| DTC   | A/F sensor 1 |           |          | Ground | Voltage         |
|-------|--------------|-----------|----------|--------|-----------------|
|       | Bank         | Connector | Terminal |        |                 |
| P0133 | 1            | F74       | 4        | Ground | Battery voltage |
| P0153 | 2            | F75       | 4        |        |                 |

Is the inspection result normal?

- YES >> GO TO 8.  
 NO >> GO TO 7.

### 7. DETECT MALFUNCTIONING PART

Check the following.

- Harness connectors E20, F40
- IPDM E/R harness connector E7
- 15 A fuse (No. 45)
- Harness for open or short between A/F sensor 1 and fuse

>> Repair or replace harness or connectors.

### 8. CHECK A/F SENSOR 1 INPUT SIGNAL CIRCUIT FOR OPEN AND SHORT

# P0133, P0153 A/F SENSOR 1

[VQ37VHR FOR MEXICO]

## < DTC/CIRCUIT DIAGNOSIS >

1. Turn ignition switch OFF.
2. Disconnect ECM harness connector.
3. Check the continuity between A/F sensor 1 harness connector and ECM harness connector.

| DTC   | A/F sensor 1 |           |          | ECM       |          | Continuity |
|-------|--------------|-----------|----------|-----------|----------|------------|
|       | Bank         | Connector | Terminal | Connector | Terminal |            |
| P0133 | 1            | F74       | 1        | F102      | 57       | Existed    |
|       |              |           | 2        |           | 61       |            |
| P0153 | 2            | F75       | 1        |           | 65       |            |
|       |              |           | 2        |           | 66       |            |

4. Check the continuity between A/F sensor 1 harness connector and ground, or ECM harness connector and ground.

| DTC   | A/F sensor 1 |           |          | Ground | Continuity  |
|-------|--------------|-----------|----------|--------|-------------|
|       | Bank         | Connector | Terminal |        |             |
| P0133 | 1            | F74       | 1        | Ground | Not existed |
|       |              |           | 2        |        |             |
| P0153 | 2            | F75       | 1        |        |             |
|       |              |           | 2        |        |             |

| DTC   | ECM  |           |          | Ground | Continuity  |
|-------|------|-----------|----------|--------|-------------|
|       | Bank | Connector | Terminal |        |             |
| P0133 | 1    | F102      | 57       | Ground | Not existed |
|       |      |           | 61       |        |             |
| P0153 | 2    |           | 65       |        |             |
|       |      |           | 66       |        |             |

5. Also check harness for short to power.

Is the inspection result normal?

YES >> GO TO 9.

NO >> Repair open circuit, short to ground or short to power in harness or connectors.

## 9. CHECK AIR FUEL RATIO (A/F) SENSOR 1 HEATER

Refer to [EC-699, "Component Inspection"](#).

Is the inspection result normal?

YES >> GO TO 10.

NO >> GO TO 13.

## 10. CHECK MASS AIR FLOW SENSOR

Check both mass air flow sensor (bank 1 and bank 2).

Refer to [EC-708, "Component Inspection"](#).

Is the inspection result normal?

YES >> GO TO 11.

NO >> Replace malfunctioning mass air flow sensor. Refer to [EM-29, "Exploded View"](#).

## 11. CHECK PCV VALVE

Refer to [EC-979, "Inspection"](#).

Is the inspection result normal?

YES >> GO TO 12.

NO >> Repair or replace PCV valve. Refer to [EM-49, "Exploded View"](#).

## 12. CHECK INTERMITTENT INCIDENT

# P0133, P0153 A/F SENSOR 1

[VQ37VHR FOR MEXICO]

< DTC/CIRCUIT DIAGNOSIS >

Perform [GI-44. "Intermittent Incident"](#).

Is the inspection result normal?

YES >> GO TO 13.

NO >> Repair or replace.

## 13.REPLACE AIR FUEL RATIO (A/F) SENSOR 1

Replace malfunctioning air fuel ratio (A/F) sensor 1.

### CAUTION:

- Discard any A/F sensor which has been dropped from a height of more than 0.5 m (19.7 in) onto a hard surface such as a concrete floor; use a new one.
- Before installing new A/F sensor, clean exhaust system threads using Oxygen Sensor Thread Cleaner [commercial service tool (J-43897-18 or J-43897-12)] and approved Anti-seize Lubricant (commercial service tool).

>> INSPECTION END

A

EC

C

D

E

F

G

H

I

J

K

L

M

N

O

P

P0137, P0157 HO2S2

DTC Logic

INFOID:000000007729834

DTC DETECTION LOGIC

The heated oxygen sensor 2 has a much longer switching time between rich and lean than the air fuel ratio (A/F) sensor 1. The oxygen storage capacity of the three way catalyst 1 causes the longer switching time. To judge malfunctions of heated oxygen sensor 2, ECM monitors whether the maximum voltage of the sensor is sufficiently high during various driving conditions such as fuel-cut.

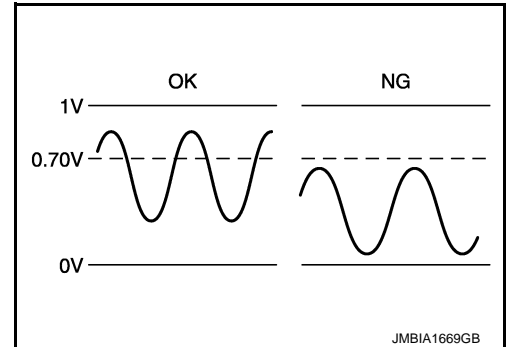

| DTC No. | Trouble diagnosis name                              | DTC detecting condition   | Possible cause  |
|---------|---|---|---|
| P0137   | Heated oxygen sensor 2 (bank 1) circuit low voltage | The maximum voltage from the sensor does not reach the specified voltage. | <ul style="list-style-type: none"> <li>• Harness or connectors (The sensor circuit is open or shorted)</li> <li>• Heated oxygen sensor 2</li> <li>• Fuel pressure</li> <li>• Fuel injector</li> <li>• Intake air leaks</li> </ul> |
| P0157   | Heated oxygen sensor 2 (bank 2) circuit low voltage |   |   |

DTC CONFIRMATION PROCEDURE

1.INSPECTION START

Do you have CONSULT?

Do you have CONSULT?

- YES >> GO TO 2.
- NO >> GO TO 5.

2.PRECONDITIONING

If DTC confirmation Procedure has been previously conducted, always perform the following procedure before conducting the next test.

1. Turn ignition switch OFF and wait at least 10 seconds.
2. Turn ignition switch ON.
3. Turn ignition switch OFF and wait at least 10 seconds.

**TESTING CONDITION:**

**For better results, perform “DTC WORK SUPPORT” at a temperature of 0 to 30°C (32 to 86°F).**

>> GO TO 3.

3.PERFORM DTC CONFIRMATION PROCEDURE

**Ⓟ With CONSULT**

1. Turn ignition switch ON and select “DATA MONITOR” mode with CONSULT.
2. Start engine and warm it up to the normal operating temperature.
3. Turn ignition switch OFF and wait at least 10 seconds.
4. Turn ignition switch ON.
5. Turn ignition switch OFF and wait at least 10 seconds.
6. Start engine and keep the engine speed between 3,500 and 4,000 rpm for at least 1 minute under no load.
7. Let engine idle for 1 minute.
8. Make sure that “COOLAN TEMP/S” indicates more than 70°C (158°F).  
If not, warm up engine and go to next step when “COOLAN TEMP/S” indication reaches 70°C (158°F).
9. Open engine hood.
10. Select “HO2S2 (B1) P1147” (for DTC P0137) or “HO2S2 (B2) P1167” (for DTC P0157) of “HO2S2” in “DTC WORK SUPPORT” mode with CONSULT.

< DTC/CIRCUIT DIAGNOSIS >

11. Start engine and follow the instruction of CONSULT display.

**NOTE:**

It will take at most 10 minutes until "COMPLETED" is displayed.

12. Touch "SELF-DIAG RESULTS".

Which is displayed on CONSULT screen?

- OK >> INSPECTION END
- NG >> Go to [EC-736. "Diagnosis Procedure"](#).
- CAN NOT BE DIAGNOSED>>GO TO 4.

**4.PERFORM DTC CONFIRMATION PROCEDURE AGAIN**

1. Turn ignition switch OFF and leave the vehicle in a cool place (soak the vehicle).
2. Perform DTC confirmation procedure again.

>> GO TO 3.

**5.PERFORM COMPONENT FUNCTION CHECK**

Perform component function check. Refer to [EC-735. "Component Function Check"](#).

**NOTE:**

Use component function check to check the overall function of the heated oxygen sensor 2 circuit. During this check, a 1st trip DTC might not be confirmed.

Is the inspection result normal?

- YES >> INSPECTION END
- NO >> Go to [EC-736. "Diagnosis Procedure"](#).

**Component Function Check**

INFOID:000000007729835

**1.PERFORM COMPONENT FUNCTION CHECK-I**

**Without CONSULT**

1. Start engine and warm it up to the normal operating temperature.
2. Turn ignition switch OFF and wait at least 10 seconds.
3. Start engine and keep the engine speed between 3,500 and 4,000 rpm for at least 1 minute under no load.
4. Let engine idle for 1 minute.
5. Check the voltage between ECM harness connector terminals under the following condition.

| DTC   | Connector | ECM      |          | Condition   | Voltage   |
|-------|-----------|----------|----------|---|---|
|       |           | +        | -        |   |   |
|       |           | Terminal | Terminal |   |   |
| P0137 | F102      | 76       | 84       | Revving up to 4,000 rpm under no load at least 10 times | The voltage should be above 0.70 V at least once during this procedure. |
| P0157 |           | 80       |          |   |   |

Is the inspection result normal?

- YES >> INSPECTION END
- NO >> GO TO 2.

**2.PERFORM COMPONENT FUNCTION CHECK-II**

Check the voltage between ECM harness connector terminals under the following condition.

| DTC   | Connector | ECM      |          | Condition                             | Voltage   |
|-------|-----------|----------|----------|---------------------------------------|---|
|       |           | +        | -        |                                       |   |
|       |           | Terminal | Terminal |                                       |   |
| P0137 | F102      | 76       | 84       | Keeping engine at idle for 10 minutes | The voltage should be above 0.70 V at least once during this procedure. |
| P0157 |           | 80       |          |                                       |   |

Is the inspection result normal?

- YES >> INSPECTION END
- NO >> GO TO 3.

**3.PERFORM COMPONENT FUNCTION CHECK-III**

Check the voltage between ECM harness connector terminals under the following condition.

| DTC            | ECM       |          |          | Condition                                    | Voltage   |
|----------------|-----------|----------|----------|--|---|
|                | Connector | +        | -        |  |   |
|                |           | Terminal | Terminal |  |   |
| P0137<br>P0157 | F102      | 76       | 84       | Coasting from 80 km/h (50 MPH) in D position | The voltage should be above 0.70 V at least once during this procedure. |
|                |           | 80       |          |  |   |

Is the inspection result normal?

- YES >> INSPECTION END
- NO >> Go to [EC-736, "Diagnosis Procedure"](#).

**Diagnosis Procedure**

INFOID:000000007729836

**1.CHECK GROUND CONNECTION**

1. Turn ignition switch OFF.
2. Check ground connection M95. Refer to Ground Inspection in [GI-47, "Circuit Inspection"](#).

Is the inspection result normal?

- YES >> GO TO 2.
- NO >> Repair or replace ground connection.

**2.CLEAR THE MIXTURE RATIO SELF-LEARNING VALUE**

1. Clear the mixture ratio self-learning value. Refer to [EC-662, "Work Procedure"](#).
2. Run engine for at least 10 minutes at idle speed.

Is the 1st trip DTC P0171 or P0174 detected? Is it difficult to start engine?

- YES >> Perform trouble diagnosis for DTC P0171 or P0174. Refer to [EC-754, "DTC Logic"](#).
- NO >> GO TO 3.

**3.CHECK HO2S2 GROUND CIRCUIT FOR OPEN AND SHORT**

1. Turn ignition switch OFF.
2. Disconnect heated oxygen sensor 2 (HO2S2) harness connector.
3. Disconnect ECM harness connector.
4. Check the continuity between HO2S2 harness connector and ECM harness connector.

| DTC   | HO2S2 |           |          | ECM       |          | Continuity |
|-------|-------|-----------|----------|-----------|----------|------------|
|       | Bank  | Connector | Terminal | Connector | Terminal |            |
| P0137 | 1     | F54       | 1        | F102      | 84       | Existed    |
| P0157 | 2     | F53       | 1        |           |          |            |

5. Also check harness for short to ground and short to power.

Is the inspection result normal?

- YES >> GO TO 4.
- NO >> Repair open circuit, short to ground or short to power in harness or connectors.

**4.CHECK HO2S2 INPUT SIGNAL CIRCUIT FOR OPEN AND SHORT**

1. Check the continuity between HO2S2 harness connector and ECM harness connector.

| DTC   | HO2S2 |           |          | ECM       |          | Continuity |
|-------|-------|-----------|----------|-----------|----------|------------|
|       | Bank  | Connector | Terminal | Connector | Terminal |            |
| P0137 | 1     | F54       | 4        | F102      | 76       | Existed    |
| P0157 | 2     | F53       | 4        |           | 80       |            |

2. Check the continuity between HO2S2 harness connector and ground, or ECM harness connector and ground.



< DTC/CIRCUIT DIAGNOSIS >

| DTC   | HO2S2 |           |          | Ground | Continuity  |
|-------|-------|-----------|----------|--------|-------------|
|       | Bank  | Connector | Terminal |        |             |
| P0137 | 1     | F54       | 4        | Ground | Not existed |
| P0157 | 2     | F53       | 4        |        |             |

| DTC   | ECM  |           |          | Ground | Continuity  |
|-------|------|-----------|----------|--------|-------------|
|       | Bank | Connector | Terminal |        |             |
| P0137 | 1    | F102      | 76       | Ground | Not existed |
| P0157 | 2    |           | 80       |        |             |

3. Also check harness for short to power.

Is the inspection result normal?

YES >> GO TO 5.

NO >> Repair open circuit, short to ground or short to power in harness or connectors.

**5.CHECK HEATED OXYGEN SENSOR 2**

Refer to [EC-737, "Component Inspection"](#).

Is the inspection result normal?

YES >> GO TO 7.

NO >> GO TO 6.

**6.REPLACE HEATED OXYGEN SENSOR 2**

Replace malfunctioning heated oxygen sensor 2.

**CAUTION:**

- Discard any heated oxygen sensor which has been dropped from a height of more than 0.5 m (19.7 in) onto a hard surface such as a concrete floor; use a new one.
- Before installing new heated oxygen sensor, clean exhaust system threads using Oxygen Sensor Thread Cleaner [commercial service tool (J-43897-18 or J-43897-12)] and approved Anti-seize Lubricant (commercial service tool).

>> INSPECTION END

**7.CHECK INTERMITTENT INCIDENT**

Refer to [GI-44, "Intermittent Incident"](#).

>> INSPECTION END

**Component Inspection**

INFOID:000000007729837

**1.INSPECTION START**

Do you have CONSULT?

Do you have CONSULT?

YES >> GO TO 2.

NO >> GO TO 3.

**2.CHECK HEATED OXYGEN SENSOR 2**

**With CONSULT**

1. Turn ignition switch ON and select "DATA MONITOR" mode with CONSULT.
2. Start engine and warm it up to the normal operating temperature.
3. Turn ignition switch OFF and wait at least 10 seconds.
4. Start engine and keep the engine speed between 3,500 and 4,000 rpm for at least 1 minute under no load.
5. Let engine idle for 1 minute.
6. Select "FUEL INJECTION" in "ACTIVE TEST" mode, and select "HO2S2 (B1)/(B2)" as the monitor item with CONSULT.

# P0137, P0157 HO2S2

< DTC/CIRCUIT DIAGNOSIS >

[VQ37VHR FOR MEXICO]

7. Check "HO2S2 (B1)/(B2)" at idle speed when adjusting "FUEL INJECTION" to  $\pm 25\%$ .

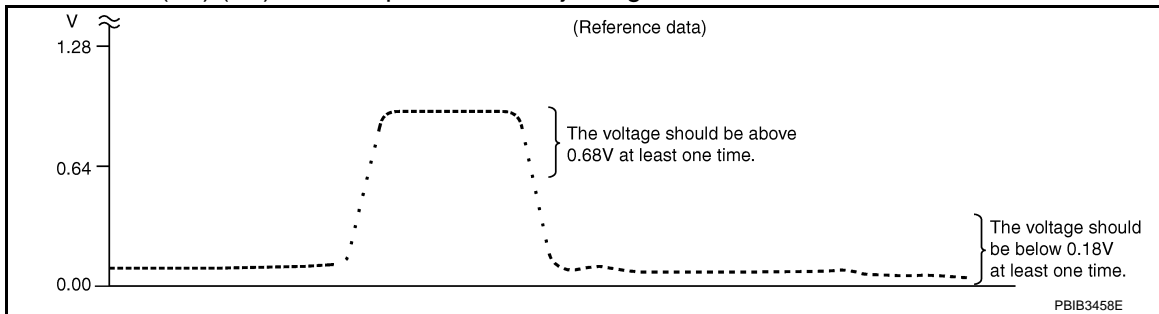

"HO2S2 (B1)/(B2)" should be above 0.70 V at least once when the "FUEL INJECTION" is +25%.

"HO2S2 (B1)/(B2)" should be below 0.18 V at least once when the "FUEL INJECTION" is -25%.

Is the inspection result normal?

YES >> INSPECTION END

NO >> GO TO 6.

## 3. CHECK HEATED OXYGEN SENSOR 2-I

⊗ Without CONSULT

1. Start engine and warm it up to the normal operating temperature.
2. Turn ignition switch OFF and wait at least 10 seconds.
3. Start engine and keep the engine speed between 3,500 and 4,000 rpm for at least 1 minute under no load.
4. Let engine idle for 1 minute.
5. Check the voltage between ECM harness connector terminals under the following condition.

| ECM       |                           |          | Condition   | Voltage  |
|-----------|---------------------------|----------|---|--|
| Connector | +                         | -        |   |  |
|           | Terminal                  | Terminal |   |  |
| F102      | 76<br>[HO2S2<br>(bank 1)] | 84       | Revving up to 4,000 rpm under no load at least 10 times | The voltage should be above 0.70 V at least once during this procedure.<br>The voltage should be below 0.18 V at least once during this procedure. |
|           | 80<br>[HO2S2<br>(bank 2)] |          |   |  |

Is the inspection result normal?

YES >> INSPECTION END

NO >> GO TO 4.

## 4. CHECK HEATED OXYGEN SENSOR 2-II

Check the voltage between ECM harness connector terminals under the following condition.

| ECM       |                           |          | Condition                             | Voltage  |
|-----------|---------------------------|----------|---------------------------------------|--|
| Connector | +                         | -        |                                       |  |
|           | Terminal                  | Terminal |                                       |  |
| F102      | 76<br>[HO2S2<br>(bank 1)] | 84       | Keeping engine at idle for 10 minutes | The voltage should be above 0.70 V at least once during this procedure.<br>The voltage should be below 0.18 V at least once during this procedure. |
|           | 80<br>[HO2S2<br>(bank 2)] |          |                                       |  |

Is the inspection result normal?

YES >> INSPECTION END

NO >> GO TO 5.

## 5. CHECK HEATED OXYGEN SENSOR 2-III

Check the voltage between ECM harness connector terminals under the following condition.

| ECM       |                           |          | Condition                                    | Voltage  |
|-----------|---------------------------|----------|--|--|
| Connector | +                         | -        |  |  |
|           | Terminal                  | Terminal |  |  |
| F102      | 76<br>[HO2S2<br>(bank 1)] | 84       | Coasting from 80 km/h (50 MPH) in D position | The voltage should be above 0.70 V at least once during this procedure.<br>The voltage should be below 0.18 V at least once during this procedure. |
|           | 80<br>[HO2S2<br>(bank 2)] |          |  |  |

A  
EC

C

D

Is the inspection result normal?

YES >> INSPECTION END  
NO >> GO TO 6.

E

**6. REPLACE HEATED OXYGEN SENSOR 2**

Replace malfunctioning heated oxygen sensor 2.

**CAUTION:**

- Discard any heated oxygen sensor which has been dropped from a height of more than 0.5 m (19.7 in) onto a hard surface such as a concrete floor; use a new one.
- Before installing new heated oxygen sensor, clean exhaust system threads using Oxygen Sensor Thread Cleaner [commercial service tool (J-43897-18 or J-43897-12)] and approved Anti-seize Lubricant (commercial service tool).

F

G

>> INSPECTION END

H

I

J

K

L

M

N

O

P

P0138, P0158 HO2S2

DTC Logic

INFOID:000000007729838

DTC DETECTION LOGIC

The heated oxygen sensor 2 has a much longer switching time between rich and lean than the air fuel ratio (A/F) sensor 1. The oxygen storage capacity of the three way catalyst 1 causes the longer switching time.

**MALFUNCTION A**

To judge malfunctions of heated oxygen sensor 2, ECM monitors whether the voltage is unusually high during various driving conditions such as fuel cut.

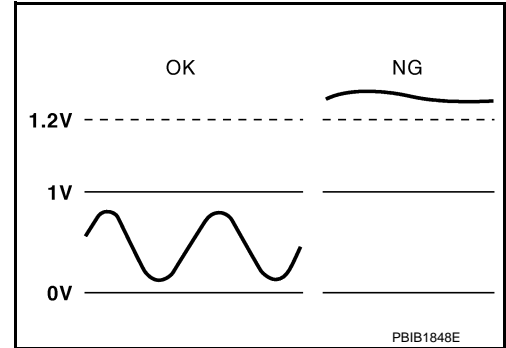

**MALFUNCTION B**

To judge malfunctions of heated oxygen sensor 2, ECM monitors whether the minimum voltage of sensor is sufficiently low during various driving conditions such as fuel cut.

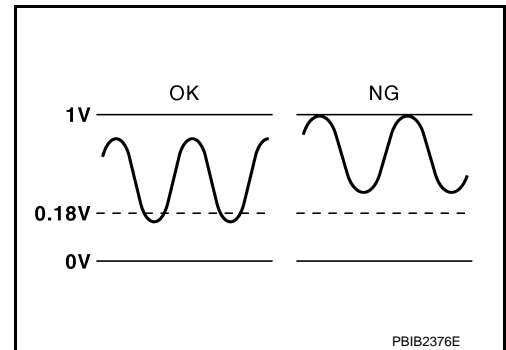

| DTC No. | Trouble diagnosis name                               | DTC detecting condition |  | Possible cause  |
|---------|--|-------------------------|--|---|
| P0138   | Heated oxygen sensor 2 (bank 1) circuit high voltage | A)                      | An excessively high voltage from the sensor is sent to ECM.                  | <ul style="list-style-type: none"> <li>• Harness or connectors (The sensor circuit is open or shorted)</li> <li>• Heated oxygen sensor 2</li> </ul>   |
|         |  | B)                      | The minimum voltage from the sensor is not reached to the specified voltage. | <ul style="list-style-type: none"> <li>• Harness or connectors (The sensor circuit is open or shorted)</li> <li>• Heated oxygen sensor 2</li> <li>• Fuel pressure</li> <li>• Fuel injector</li> </ul> |
| P0158   | Heated oxygen sensor 2 (bank 2) circuit high voltage | A)                      | An excessively high voltage from the sensor is sent to ECM.                  | <ul style="list-style-type: none"> <li>• Harness or connectors (The sensor circuit is open or shorted)</li> <li>• Heated oxygen sensor 2</li> </ul>   |
|         |  | B)                      | The minimum voltage from the sensor is not reached to the specified voltage. | <ul style="list-style-type: none"> <li>• Harness or connectors (The sensor circuit is open or shorted)</li> <li>• Heated oxygen sensor 2</li> <li>• Fuel pressure</li> <li>• Fuel injector</li> </ul> |

DTC CONFIRMATION PROCEDURE

1. PRECONDITIONING

If DTC Confirmation Procedure has been previously conducted, always perform the following procedure before conducting the next test.

1. Turn ignition switch OFF and wait at least 10 seconds.
2. Turn ignition switch ON.
3. Turn ignition switch OFF and wait at least 10 seconds.

>> GO TO 2.

## 2. PERFORM DTC CONFIRMATION PROCEDURE FOR MALFUNCTION A

1. Start engine and warm it up to the normal operating temperature.
2. Turn ignition switch OFF and wait at least 10 seconds.
3. Turn ignition switch ON.
4. Turn ignition switch OFF and wait at least 10 seconds.
5. Start engine and keep the engine speed between 3,500 and 4,000 rpm for at least 1 minute under no load.
6. Let engine idle for 2 minutes.
7. Check 1st trip DTC.

Is 1st trip DTC detected?

YES >> Go to [EC-742, "Diagnosis Procedure"](#).

NO-1 >> With CONSULT: GO TO 3.

NO-2 >> Without CONSULT: GO TO 5.

## 3. PERFORM DTC CONFIRMATION PROCEDURE FOR MALFUNCTION B

### NOTE:

**For better results, perform "DTC WORK SUPPORT" at a temperature of 0 to 30 °C (32 to 86 °F).**

1. Select "DATA MONITOR" mode with CONSULT.
2. Start engine and warm it up to the normal operating temperature.
3. Turn ignition switch OFF and wait at least 10 seconds.
4. Turn ignition switch ON.
5. Turn ignition switch OFF and wait at least 10 seconds.
6. Start engine and keep the engine speed between 3,500 and 4,000 rpm for at least 1 minute under no load.
7. Let engine idle for 1 minute.
8. Make sure that "COOLAN TEMP/S" indicates more than 70°C (158°F).  
If not, warm up engine and go to next step when "COOLAN TEMP/S" indication reaches 70°C (158°F).
9. Open engine hood.
10. Select "HO2S2 (B1) P1146" (for DTC P0138) or "HO2S2 (B2) P1166" (for DTC P0158) of "HO2S2" in "DTC WORK SUPPORT" mode with CONSULT.
11. Start engine and follow the instruction of CONSULT display.

### NOTE:

It will take at most 10 minutes until "COMPLETED" is displayed.

12. Touch "SELF-DIAG RESULTS".

Which is displayed on CONSULT screen?

OK >> INSPECTION END

NG >> Go to [EC-742, "Diagnosis Procedure"](#).

CON NOT BE DIAGNOSED>>GO TO 4.

## 4. PERFORM DTC CONFIRMATION PROCEDURE FOR MALFUNCTION B AGAIN

1. Turn ignition switch OFF and leave the vehicle in a cool place (soak the vehicle).
2. Perform DTC confirmation procedure again.

>> GO TO 3.

## 5. PERFORM COMPONENT FUNCTION CHECK FOR MALFUNCTION B

Perform component function check. Refer to [EC-741, "Component Function Check"](#).

### NOTE:

Use component function check to check the overall function of the heated oxygen sensor 2 circuit. During this check, a 1st trip DTC might not be confirmed.

Is the inspection result normal?

YES >> INSPECTION END

NO >> Go to [EC-742, "Diagnosis Procedure"](#).

## Component Function Check

INFOID:00000000729839

## 1. PERFORM COMPONENT FUNCTION CHECK-I

< DTC/CIRCUIT DIAGNOSIS >

⊗ Without CONSULT

1. Start engine and warm it up to the normal operating temperature.
2. Turn ignition switch OFF and wait at least 10 seconds.
3. Start engine and keep the engine speed between 3,500 and 4,000 rpm for at least 1 minute under no load.
4. Let engine idle for 1 minute.
5. Check the voltage between ECM harness connector terminals under the following condition.

| DTC   | ECM       |          |          | Condition   | Voltage   |
|-------|-----------|----------|----------|---|---|
|       | Connector | +        | -        |   |   |
|       |           | Terminal | Terminal |   |   |
| P0138 | F102      | 76       | 84       | Revving up to 4,000 rpm under no load at least 10 times | The voltage should be below 0.18 V at least once during this procedure. |
| P0158 |           | 80       |          |   |   |

Is the inspection result normal?

- YES >> INSPECTION END  
 NO >> GO TO 2.

**2.PERFORM COMPONENT FUNCTION CHECK-II**

Check the voltage between ECM harness connector terminals under the following condition.

| DTC   | ECM       |          |          | Condition                             | Voltage   |
|-------|-----------|----------|----------|---------------------------------------|---|
|       | Connector | +        | -        |                                       |   |
|       |           | Terminal | Terminal |                                       |   |
| P0138 | F102      | 76       | 84       | Keeping engine at idle for 10 minutes | The voltage should be below 0.18 V at least once during this procedure. |
| P0158 |           | 80       |          |                                       |   |

Is the inspection result normal?

- YES >> INSPECTION END  
 NO >> GO TO 3.

**3.PERFORM COMPONENT FUNCTION CHECK-III**

Check the voltage between ECM harness connector terminals under the following condition.

| DTC   | ECM       |          |          | Condition                                    | Voltage   |
|-------|-----------|----------|----------|--|---|
|       | Connector | +        | -        |  |   |
|       |           | Terminal | Terminal |  |   |
| P0138 | F102      | 76       | 84       | Coasting from 80 km/h (50 MPH) in D position | The voltage should be below 0.18 V at least once during this procedure. |
| P0158 |           | 80       |          |  |   |

Is the inspection result normal?

- YES >> INSPECTION END  
 NO >> Go to [EC-742, "Diagnosis Procedure"](#).

**Diagnosis Procedure**

INFOID:000000007729840

**1.INSPECTION START**

Confirm the detected malfunction (A or B). Refer to [EC-740, "DTC Logic"](#).

Which malfunction is detected?

- A >> GO TO 2  
 B >> GO TO 9.

**2.CHECK GROUND CONNECTION**

1. Turn ignition switch OFF.
2. Check ground connection M95. Refer to Ground Inspection in [GI-47, "Circuit Inspection"](#).

Is the inspection result normal?

< DTC/CIRCUIT DIAGNOSIS >

- YES >> GO TO 3.
- NO >> Repair or replace ground connection.

**3.CHECK HO2S2 GROUND CIRCUIT FOR OPEN AND SHORT**

1. Disconnect heated oxygen sensor 2 (HO2S2) harness connector.
2. Disconnect ECM harness connector.
3. Check the continuity between HO2S2 harness connector and ECM harness connector.

| DTC   | HO2S2 |           |          | ECM       |          | Continuity |
|-------|-------|-----------|----------|-----------|----------|------------|
|       | Bank  | Connector | Terminal | Connector | Terminal |            |
| P0138 | 1     | F54       | 1        | F102      | 84       | Existed    |
| P0158 | 2     | F53       | 1        |           |          |            |

4. Also check harness for short to ground and short to power.

Is the inspection result normal?

- YES >> GO TO 4.
- NO >> Repair open circuit, short to ground or short to power in harness or connectors.

**4.CHECK HO2S2 INPUT SIGNAL CIRCUIT FOR OPEN AND SHORT**

1. Check the continuity between HO2S2 harness connector and ECM harness connector.

| DTC   | HO2S2 |           |          | ECM       |          | Continuity |
|-------|-------|-----------|----------|-----------|----------|------------|
|       | Bank  | Connector | Terminal | Connector | Terminal |            |
| P0138 | 1     | F54       | 4        | F102      | 76       | Existed    |
| P0158 | 2     | F53       | 4        |           | 80       |            |

2. Check the continuity between HO2S2 harness connector and ground, or ECM harness connector and ground.

| DTC   | HO2S2 |           |          | Ground | Continuity  |
|-------|-------|-----------|----------|--------|-------------|
|       | Bank  | Connector | Terminal |        |             |
| P0138 | 1     | F54       | 4        | Ground | Not existed |
| P0158 | 2     | F53       | 4        |        |             |

| DTC   | ECM  |           |          | Ground | Continuity  |
|-------|------|-----------|----------|--------|-------------|
|       | Bank | Connector | Terminal |        |             |
| P0138 | 1    | F102      | 76       | Ground | Not existed |
| P0158 | 2    |           | 80       |        |             |

3. Also check harness for short to power.

Is the inspection result normal?

- YES >> GO TO 5.
- NO >> Repair open circuit, short to ground or short to power in harness or connectors.

**5.CHECK HO2S2 CONNECTOR FOR WATER**

Check connectors for water.

**Water should not exist.**

Is the inspection result normal?

- YES >> GO TO 6.
- NO >> Repair or replace harness or connectors.

**6.CHECK HEATED OXYGEN SENSOR 2**

Refer to [EC-745, "Component Inspection"](#).

< DTC/CIRCUIT DIAGNOSIS >

Is the inspection result normal?

- YES >> GO TO 8.
- NO >> GO TO 7.

**7.**REPLACE HEATED OXYGEN SENSOR 2

Replace malfunctioning heated oxygen sensor 2.

**CAUTION:**

- Discard any heated oxygen sensor which has been dropped from a height of more than 0.5 m (19.7 in) onto a hard surface such as a concrete floor; use a new one.
- Before installing new heated oxygen sensor, clean exhaust system threads using Oxygen Sensor Thread Cleaner [commercial service tool (J-43897-18 or J-43897-12)] and approved Anti-seize Lubricant (commercial service tool).

>> INSPECTION END

**8.**CHECK INTERMITTENT INCIDENT

Refer to [GI-44, "Intermittent Incident"](#).

>> INSPECTION END

**9.**CHECK GROUND CONNECTION

1. Turn ignition switch OFF.
2. Check ground connection M95. Refer to Ground Inspection in [GI-47, "Circuit Inspection"](#).

Is the inspection result normal?

- YES >> GO TO 10.
- NO >> Repair or replace ground connection.

**10.**CLEAR THE MIXTURE RATIO SELF-LEARNING VALUE

1. Clear the mixture ratio self-learning value. Refer to [EC-662, "Work Procedure"](#).
2. Run engine for at least 10 minutes at idle speed.

Is the 1st trip DTC P0172 or P0175 detected? Is it difficult to start engine?

- YES >> Perform trouble diagnosis for DTC P0172, P0175. Refer to [EC-758, "DTC Logic"](#).
- NO >> GO TO 11.

**11.**CHECK HO2S2 GROUND CIRCUIT FOR OPEN AND SHORT

1. Turn ignition switch OFF.
2. Disconnect heated oxygen sensor 2 harness connector.
3. Disconnect ECM harness connector.
4. Check the continuity between HO2S2 harness connector and ECM harness connector.

| DTC   | HO2S2 |           |          | ECM       |          | Continuity |
|-------|-------|-----------|----------|-----------|----------|------------|
|       | Bank  | Connector | Terminal | Connector | Terminal |            |
| P0138 | 1     | F54       | 1        | F102      | 84       | Existed    |
| P0158 | 2     | F53       | 1        |           |          |            |

5. Also check harness for short to ground and short to power.

Is the inspection result normal?

- YES >> GO TO 12.
- NO >> Repair open circuit, short to ground or short to power in harness or connectors.

**12.**CHECK HO2S2 INPUT SIGNAL CIRCUIT FOR OPEN AND SHORT

1. Check the continuity between HO2S2 harness connector and ECM harness connector.



< DTC/CIRCUIT DIAGNOSIS >

| DTC   | HO2S2 |           |          | ECM       |          | Continuity |
|-------|-------|-----------|----------|-----------|----------|------------|
|       | Bank  | Connector | Terminal | Connector | Terminal |            |
| P0138 | 1     | F54       | 4        | F102      | 76       | Existed    |
| P0158 | 2     | F53       | 4        |           | 80       |            |

2. Check the continuity between HO2S2 harness connector or ECM harness connector and ground.

| DTC   | HO2S2 |           |          | Ground | Continuity  |
|-------|-------|-----------|----------|--------|-------------|
|       | Bank  | Connector | Terminal |        |             |
| P0138 | 1     | F54       | 4        | Ground | Not existed |
| P0158 | 2     | F53       | 4        |        |             |

| DTC   | ECM  |           |          | Ground | Continuity  |
|-------|------|-----------|----------|--------|-------------|
|       | Bank | Connector | Terminal |        |             |
| P0138 | 1    | F102      | 76       | Ground | Not existed |
| P0158 | 2    |           | 80       |        |             |

3. Also check harness for short to power.

Is the inspection result normal?

YES >> GO TO 13.

NO >> Repair open circuit, short to ground or short to power in harness or connectors.

**13.CHECK HEATED OXYGEN SENSOR 2**

Refer to [EC-741. "Component Function Check"](#).

Is the inspection result normal?

YES >> GO TO 15.

NO >> GO TO 14.

**14.REPLACE HEATED OXYGEN SENSOR 2**

Replace malfunctioning heated oxygen sensor 2.

**CAUTION:**

- Discard any heated oxygen sensor which has been dropped from a height of more than 0.5 m (19.7 in) onto a hard surface such as a concrete floor; use a new one.
- Before installing new heated oxygen sensor, clean exhaust system threads using Oxygen Sensor Thread Cleaner [commercial service tool (J-43897-18 or J-43897-12)] and approved Anti-seize Lubricant (commercial service tool).

>> INSPECTION END

**15.CHECK INTERMITTENT INCIDENT**

Refer to [GI-44. "Intermittent Incident"](#).

>> INSPECTION END

**Component Inspection**

INFOID:000000007729841

**1.INSPECTION START**

Do you have CONSULT?

Do you have CONSULT?

YES >> GO TO 2.

NO >> GO TO 3.

**2.CHECK HEATED OXYGEN SENSOR 2**

 **With CONSULT**

A  
EC  
C  
D  
E  
F  
G  
H  
I  
J  
K  
L  
M  
N  
O  
P

# P0138, P0158 HO2S2

[VQ37VHR FOR MEXICO]

## < DTC/CIRCUIT DIAGNOSIS >

1. Turn ignition switch ON and select "DATA MONITOR" mode with CONSULT.
2. Start engine and warm it up to the normal operating temperature.
3. Turn ignition switch OFF and wait at least 10 seconds.
4. Start engine and keep the engine speed between 3,500 and 4,000 rpm for at least 1 minute under no load.
5. Let engine idle for 1 minute.
6. Select "FUEL INJECTION" in "ACTIVE TEST" mode, and select "HO2S2 (B1)/(B2)" as the monitor item with CONSULT.
7. Check "HO2S2 (B1)/(B2)" at idle speed when adjusting "FUEL INJECTION" to  $\pm 25\%$ .

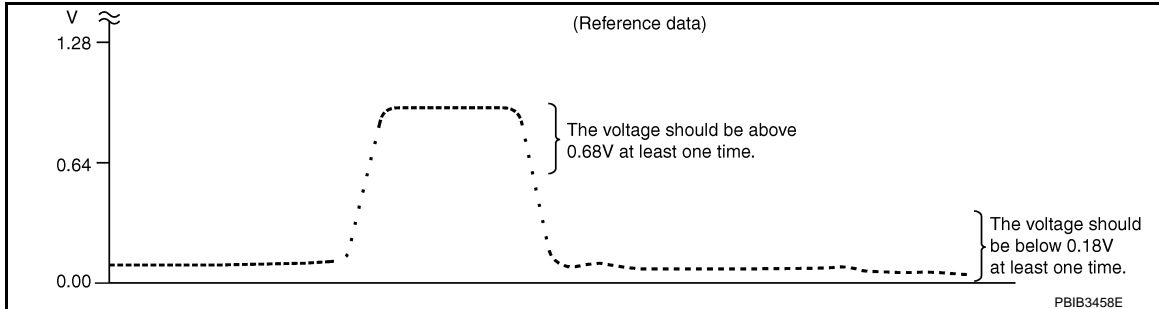

"HO2S2 (B1)/(B2)" should be above 0.70 V at least once when the "FUEL INJECTION" is +25%.  
 "HO2S2 (B1)/(B2)" should be below 0.18 V at least once when the "FUEL INJECTION" is -25%.

Is the inspection result normal?

- YES >> INSPECTION END  
 NO >> GO TO 6.

### 3. CHECK HEATED OXYGEN SENSOR 2-I

#### ⊗ Without CONSULT

1. Start engine and warm it up to the normal operating temperature.
2. Turn ignition switch OFF and wait at least 10 seconds.
3. Start engine and keep the engine speed between 3,500 and 4,000 rpm for at least 1 minute under no load.
4. Let engine idle for 1 minute.
5. Check the voltage between ECM harness connector terminals under the following condition.

| Connector | ECM                       |          | Condition   | Voltage  |
|-----------|---------------------------|----------|---|--|
|           | +                         | -        |   |  |
|           | Terminal                  | Terminal |   |  |
| F102      | 76<br>[HO2S2<br>(bank 1)] | 84       | Revving up to 4,000 rpm under no load at least 10 times | The voltage should be above 0.70 V at least once during this procedure.<br>The voltage should be below 0.18 V at least once during this procedure. |
|           | 80<br>[HO2S2<br>(bank 2)] |          |   |  |

Is the inspection result normal?

- YES >> INSPECTION END  
 NO >> GO TO 4.

### 4. CHECK HEATED OXYGEN SENSOR 2-II

Check the voltage between ECM harness connector terminals under the following condition.

| ECM       |                           |          | Condition                             | Voltage  |
|-----------|---------------------------|----------|---------------------------------------|--|
| Connector | +                         | -        |                                       |  |
|           | Terminal                  | Terminal |                                       |  |
| F102      | 76<br>[HO2S2<br>(bank 1)] | 84       | Keeping engine at idle for 10 minutes | The voltage should be above 0.70 V at least once during this procedure.<br>The voltage should be below 0.18 V at least once during this procedure. |
|           | 80<br>[HO2S2<br>(bank 2)] |          |                                       |  |

A

EC

C

Is the inspection result normal?

D

YES >> INSPECTION END  
NO >> GO TO 5.

**5.CHECK HEATED OXYGEN SENSOR 2-III**

E

Check the voltage between ECM harness connector terminals under the following condition.

| ECM       |                           |          | Condition                                    | Voltage  |
|-----------|---------------------------|----------|--|--|
| Connector | +                         | -        |  |  |
|           | Terminal                  | Terminal |  |  |
| F102      | 76<br>[HO2S2<br>(bank 1)] | 84       | Coasting from 80 km/h (50 MPH) in D position | The voltage should be above 0.70 V at least once during this procedure.<br>The voltage should be below 0.18 V at least once during this procedure. |
|           | 80<br>[HO2S2<br>(bank 2)] |          |  |  |

F

G

H

I

Is the inspection result normal?

YES >> INSPECTION END  
NO >> GO TO 6.

J

**6.REPLACE HEATED OXYGEN SENSOR 2**

Replace malfunctioning heated oxygen sensor 2.

K

**CAUTION:**

- Discard any heated oxygen sensor which has been dropped from a height of more than 0.5 m (19.7 in) onto a hard surface such as a concrete floor; use a new one.
- Before installing new heated oxygen sensor, clean exhaust system threads using Oxygen Sensor Thread Cleaner [commercial service tool (J-43897-18 or J-43897-12)] and approved Anti-seize Lubricant (commercial service tool).

L

M

>> INSPECTION END

N

O

P

P0139, P0159 HO2S2

DTC Logic

INFOID:000000007729842

DTC DETECTION LOGIC

The heated oxygen sensor 2 has a much longer switching time between rich and lean than the air fuel ratio (A/F) sensor 1. The oxygen storage capacity of the three way catalyst 1 causes the longer switching time. To judge the malfunctions of heated oxygen sensor 2, ECM monitors whether the switching response of the sensor's voltage is faster than specified during various driving conditions such as fuel cut.

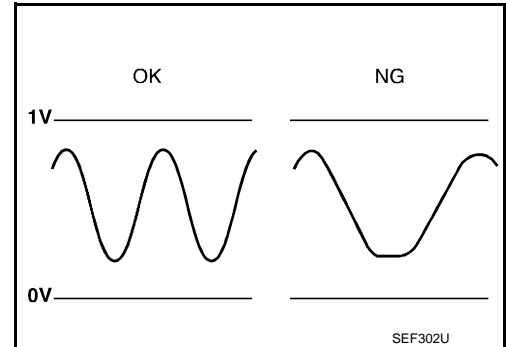

| DTC No. | Trouble diagnosis name                                | DTC detecting condition   | Possible cause  |
|---------|---|---|---|
| P0139   | Heated oxygen sensor 2 (bank 1) circuit slow response | It takes more time for the sensor to respond between rich and lean than the specified time. | <ul style="list-style-type: none"> <li>• Harness or connectors (The sensor circuit is open or shorted)</li> <li>• Heated oxygen sensor 2</li> <li>• Fuel pressure</li> <li>• Fuel injector</li> <li>• Intake air leaks</li> </ul> |
| P0159   | Heated oxygen sensor 2 (bank 2) circuit slow response |   |   |

DTC CONFIRMATION PROCEDURE

1.INSPECTION START

Do you have CONSULT?

Do you have CONSULT?

YES >> GO TO 2.

NO >> GO TO 6.

2.PRECONDITIONING

If DTC Confirmation Procedure has been previously conducted, always perform the following procedure before conducting the next test.

1. Turn ignition switch OFF and wait at least 10 seconds.
2. Turn ignition switch ON.
3. Turn ignition switch OFF and wait at least 10 seconds.

**TESTING CONDITION:**

For better results, perform "DTC WORK SUPPORT" at a temperature of 0 to 30°C (32 to 86°F).

>> GO TO 3.

3.PERFORM DTC CONFIRMATION PROCEDURE

Ⓟ With CONSULT

1. Turn ignition switch ON and select "DATA MONITOR" mode with CONSULT.
2. Start engine and warm it up to the normal operating temperature.
3. Turn ignition switch OFF and wait at least 10 seconds.
4. Turn ignition switch ON.
5. Turn ignition switch OFF and wait at least 10 seconds.
6. Start engine and keep the engine speed between 3,500 and 4,000 rpm for at least 1 minute under no load.
7. Let engine idle for 1 minute.
8. Make sure that "COOLAN TEMP/S" indicates more than 70°C (158°F).
9. Open engine hood.
10. Select "HO2S2 (B1) P0139" or "HO2S2 (B2) P0159" of "HO2S2" in "DTC WORK SUPPORT" mode with CONSULT.
11. Start engine and follow the instruction of CONSULT display.

< DTC/CIRCUIT DIAGNOSIS >

**NOTE:**

It will take at most 10 minutes until "COMPLETED" is displayed.

Is "COMPLETED" displayed on CONSULT screen?

- YES >> GO TO 5.
- NO >> GO TO 4.

**4.PERFORM DTC CONFIRMATION PROCEDURE AGAIN**

1. Turn ignition switch OFF and leave the vehicle in a cool place (soak the vehicle).
2. Perform DTC confirmation procedure again.

>> GO TO 3.

**5.PERFORM SELF-DIAGNOSIS**

**With CONSULT**

Perform ECM self-diagnosis.

Is DTC "P0139" or "P0159" detected?

- YES >> Proceed to [EC-750, "Diagnosis Procedure"](#).
- NO >> INSPECTION END

**6.PERFORM COMPONENT FUNCTION CHECK**

Perform component function check. Refer to [EC-749, "Component Function Check"](#).

**NOTE:**

Use component function check to check the overall function of the heated oxygen sensor 2 circuit. During this check, a 1st trip DTC might not be confirmed.

Is the inspection result normal?

- YES >> INSPECTION END
- NO >> Proceed to [EC-750, "Diagnosis Procedure"](#).

**Component Function Check**

INFOID:000000007729843

**1.PERFORM COMPONENT FUNCTION CHECK-I**

**Without CONSULT**

1. Start engine and warm it up to the normal operating temperature.
2. Turn ignition switch OFF and wait at least 10 seconds.
3. Start engine and keep the engine speed between 3,500 and 4,000 rpm for at least 1 minute under no load.
4. Let engine idle for 1 minute.
5. Check the voltage between ECM harness connector terminals under the following condition.

| DTC   | ECM       |          | Condition | Voltage   |  |
|-------|-----------|----------|-----------|---|--|
|       | Connector | Terminal |           |   |  |
|       |           | +        |           |   | -  |
| P0139 | F102      | 76       | 84        | Revving up to 4,000 rpm under no load at least 10 times |  |
| P0159 |           | 80       |           |   | A change of voltage should be more than 0.08 V for 1 second during this procedure. |

Is the inspection result normal?

- YES >> INSPECTION END
- NO >> GO TO 2.

**2.PERFORM COMPONENT FUNCTION CHECK-II**

Check the voltage between ECM harness connector terminals under the following condition.

# P0139, P0159 HO2S2

< DTC/CIRCUIT DIAGNOSIS >

[VQ37VHR FOR MEXICO]

| DTC   | ECM       |          |    | Condition                             | Voltage  |
|-------|-----------|----------|----|---------------------------------------|--|
|       | Connector | Terminal |    |                                       |  |
|       |           | +        | -  |                                       |  |
| P0139 | F102      | 76       | 84 | Keeping engine at idle for 10 minutes | A change of voltage should be more than 0.08 V for 1 second during this procedure. |
| P0159 |           | 80       |    |                                       |  |

Is the inspection result normal?

- YES >> INSPECTION END
- NO >> GO TO 3.

## 3.PERFORM COMPONENT FUNCTION CHECK-III

Check the voltage between ECM harness connector terminals under the following condition.

| DTC   | ECM       |          |          |  | Condition  | Voltage  |
|-------|-----------|----------|----------|--|--|--|
|       | Connector | +        | -        |  |  |  |
|       |           | Terminal | Terminal |  |  |  |
| P0139 | F102      | 76       | 84       |  | Coasting from 80 km/h (50 MPH) on the suitable gear position | A change of voltage should be more than 0.08 V for 1 second during this procedure. |
| P0159 |           | 80       |          |  |  |  |

Is the inspection result normal?

- YES >> INSPECTION END
- NO >> Proceed to [EC-750, "Diagnosis Procedure"](#).

## Diagnosis Procedure

INFOID:000000007729844

### 1.CHECK GROUND CONNECTION

1. Turn ignition switch OFF.
2. Check ground connection M95. Refer to Ground Inspection in [GI-47, "Circuit Inspection"](#).

Is the inspection result normal?

- YES >> GO TO 2.
- NO >> Repair or replace ground connection.

### 2.CLEAR THE MIXTURE RATIO SELF-LEARNING VALUE

1. Clear the mixture ratio self-learning value. Refer to [EC-662, "Work Procedure"](#).
2. Run engine for at least 10 minutes at idle speed.

Is the 1st trip DTC P0171, P0172, P0174 or P0175 detected? Is it difficult to start engine?

- YES >> Perform trouble diagnosis for DTC P0171, P0174 or P0172, P0175. Refer to [EC-754, "DTC Logic"](#) or [EC-758, "DTC Logic"](#).
- NO >> GO TO 3.

### 3.CHECK HO2S2 GROUND CIRCUIT FOR OPEN AND SHORT

1. Turn ignition switch OFF.
2. Disconnect heated oxygen sensor 2 (HO2S2) harness connector.
3. Disconnect ECM harness connector.
4. Check the continuity between HO2S2 harness connector and ECM harness connector.

| DTC   | HO2S2 |           |          | ECM       |          | Continuity |
|-------|-------|-----------|----------|-----------|----------|------------|
|       | Bank  | Connector | Terminal | Connector | Terminal |            |
| P0139 | 1     | F54       | 1        | F102      | 84       | Existed    |
| P0159 | 2     | F53       | 1        |           |          |            |

5. Also check harness for short to ground and short to power.

Is the inspection result normal?

- YES >> GO TO 4.

< DTC/CIRCUIT DIAGNOSIS >

NO >> Repair open circuit, short to ground or short to power in harness or connectors.

**4.CHECK HO2S2 INPUT SIGNAL CIRCUIT FOR OPEN AND SHORT**

1. Check the continuity between HO2S2 harness connector and ECM harness connector.

| DTC   | HO2S2 |           |          | ECM       |          | Continuity |
|-------|-------|-----------|----------|-----------|----------|------------|
|       | Bank  | Connector | Terminal | Connector | Terminal |            |
| P0139 | 1     | F54       | 4        | F102      | 76       | Existed    |
| P0159 | 2     | F53       | 4        |           | 80       |            |

2. Check the continuity between HO2S2 harness connector and ground, or ECM harness connector and ground.

| DTC   | HO2S2 |           |          | Ground | Continuity  |
|-------|-------|-----------|----------|--------|-------------|
|       | Bank  | Connector | Terminal |        |             |
| P0139 | 1     | F54       | 4        | Ground | Not existed |
| P0159 | 2     | F53       | 4        |        |             |

| DTC   | ECM  |           |          | Ground | Continuity  |
|-------|------|-----------|----------|--------|-------------|
|       | Bank | Connector | Terminal |        |             |
| P0139 | 1    | F102      | 76       | Ground | Not existed |
| P0159 | 2    |           | 80       |        |             |

3. Also check harness for short to power.

Is the inspection result normal?

YES >> GO TO 5.

NO >> Repair open circuit, short to ground or short to power in harness or connectors.

**5.CHECK HEATED OXYGEN SENSOR 2**

Refer to [EC-751. "Component Inspection"](#).

Is the inspection result normal?

YES >> GO TO 7.

NO >> GO TO 6.

**6.REPLACE HEATED OXYGEN SENSOR 2**

Replace malfunctioning heated oxygen sensor 2.

**CAUTION:**

- Discard any heated oxygen sensor which has been dropped from a height of more than 0.5 m (19.7 in) onto a hard surface such as a concrete floor; use a new one.
- Before installing new heated oxygen sensor, clean exhaust system threads using Oxygen Sensor Thread Cleaner [commercial service tool (J-43897-18 or J-43897-12)] and approved Anti-seize Lubricant (commercial service tool).

>> INSPECTION END

**7.CHECK INTERMITTENT INCIDENT**

Refer to [GI-44. "Intermittent Incident"](#).

>> INSPECTION END

**Component Inspection**

INFOID:000000007729845

**1.INSPECTION START**

Do you have CONSULT?

Do you have CONSULT?

< DTC/CIRCUIT DIAGNOSIS >

- YES >> GO TO 2.
- NO >> GO TO 3.

**2. CHECK HEATED OXYGEN SENSOR 2**

**With CONSULT**

1. Turn ignition switch ON and select "DATA MONITOR" mode with CONSULT.
2. Start engine and warm it up to the normal operating temperature.
3. Turn ignition switch OFF and wait at least 10 seconds.
4. Start engine and keep the engine speed between 3,500 and 4,000 rpm for at least 1 minute under no load.
5. Let engine idle for 1 minute.
6. Select "FUEL INJECTION" in "ACTIVE TEST" mode, and select "HO2S2 (B1)/(B2)" as the monitor item with CONSULT.
7. Check "HO2S2 (B1) / (B2)" at idle speed when adjusting "FUEL INJECTION" to  $\pm 25\%$ .

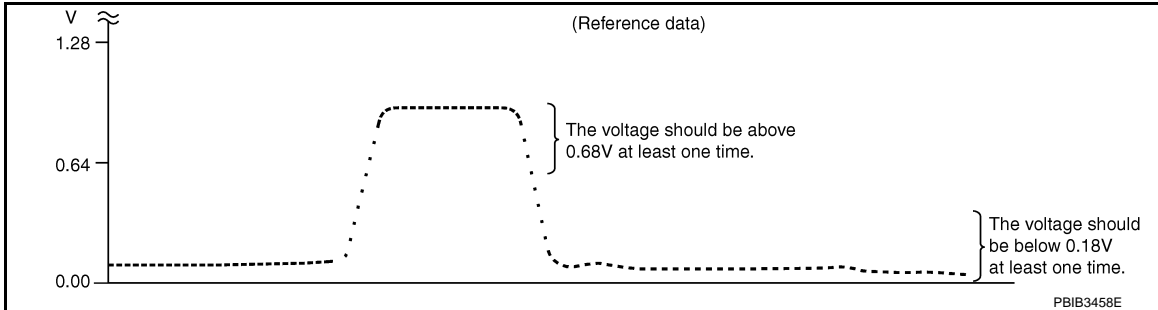

"HO2S2 (B1)/(B2)" should be above 0.70 V at least once when the "FUEL INJECTION" is +25%.  
 "HO2S2 (B1)/(B2)" should be below 0.18 V at least once when the "FUEL INJECTION" is -25%.

Is the inspection result normal?

- YES >> INSPECTION END
- NO >> GO TO 6.

**3. CHECK HEATED OXYGEN SENSOR 2-I**

**Without CONSULT**

1. Start engine and warm it up to the normal operating temperature.
2. Turn ignition switch OFF and wait at least 10 seconds.
3. Start engine and keep the engine speed between 3,500 and 4,000 rpm for at least 1 minute under no load.
4. Let engine idle for 1 minute.
5. Check the voltage between ECM harness connector terminals under the following condition.

| ECM       |                           | Condition   | Voltage   |
|-----------|---------------------------|---|---|
| Connector | + Terminal                |   |   |
| F102      | 76<br>[HO2S2<br>(bank 1)] | Revving up to 4,000 rpm under no load at least 10 times | The voltage should be above 0.40 V at least once during this procedure. |
|           | 80<br>[HO2S2<br>(bank 2)] |   |   |

Is the inspection result normal?

- YES >> INSPECTION END
- NO >> GO TO 4.

**4. CHECK HEATED OXYGEN SENSOR 2-II**

Check the voltage between ECM harness connector terminals under the following condition.



| ECM       |                           |          | Condition                             | Voltage   |
|-----------|---------------------------|----------|---------------------------------------|---|
| Connector | +                         | -        |                                       |   |
|           | Terminal                  | Terminal |                                       |   |
| F102      | 76<br>[HO2S2<br>(bank 1)] | 84       | Keeping engine at idle for 10 minutes | The voltage should be above 0.40 V at least once during this procedure. |
|           | 80<br>[HO2S2<br>(bank 2)] |          |                                       |   |

Is the inspection result normal?

- YES >> INSPECTION END
- NO >> GO TO 5.

**5.CHECK HEATED OXYGEN SENSOR 2-III**

Check the voltage between ECM harness connector terminals under the following condition.

| ECM       |                           |          | Condition  | Voltage   |
|-----------|---------------------------|----------|--|---|
| Connector | +                         | -        |  |   |
|           | Terminal                  | Terminal |  |   |
| F102      | 76<br>[HO2S2<br>(bank 1)] | 84       | Coasting from 80 km/h (50 MPH) on the suitable gear position | The voltage should be above 0.40 V at least once during this procedure. |
|           | 80<br>[HO2S2<br>(bank 2)] |          |  |   |

Is the inspection result normal?

- YES >> INSPECTION END
- NO >> GO TO 6.

**6.REPLACE HEATED OXYGEN SENSOR 2**

Replace malfunctioning heated oxygen sensor 2.

**CAUTION:**

- Discard any heated oxygen sensor which has been dropped from a height of more than 0.5 m (19.7 in) onto a hard surface such as a concrete floor; use a new one.
- Before installing new heated oxygen sensor, clean exhaust system threads using Oxygen Sensor Thread Cleaner [commercial service tool (J-43897-18 or J-43897-12)] and approved Anti-seize Lubricant (commercial service tool).

>> INSPECTION END

# P0171, P0174 FUEL INJECTION SYSTEM FUNCTION

< DTC/CIRCUIT DIAGNOSIS >

[VQ37VHR FOR MEXICO]

## P0171, P0174 FUEL INJECTION SYSTEM FUNCTION

### DTC Logic

INFOID:000000007729846

#### DTC DETECTION LOGIC

With the Air/Fuel Mixture Ratio Self-Learning Control, the actual mixture ratio can be brought closely to the theoretical mixture ratio based on the mixture ratio feedback signal from A/F sensor 1. The ECM calculates the necessary compensation to correct the offset between the actual and the theoretical ratios.

In case the amount of the compensation value is extremely large (the actual mixture ratio is too lean), the ECM judges the condition as the fuel injection system malfunction and illuminates the MIL (2 trip detection logic).

| Sensor       | Input signal to ECM   | ECM function           | Actuator      |
|--------------|---|------------------------|---------------|
| A/F sensor 1 | Density of oxygen in exhaust gas<br>(Mixture ratio feedback signal) | Fuel injection control | Fuel injector |

| DTC No. | Trouble diagnosis name                  | DTC detecting condition   | Possible cause   |
|---------|---|---|--|
| P0171   | Fuel injection system too lean (bank 1) | • Fuel injection system does not operate properly.<br>• The amount of mixture ratio compensation is too large. (The mixture ratio is too lean.) | • Intake air leaks<br>• A/F sensor 1<br>• Fuel injector<br>• Exhaust gas leaks<br>• Incorrect fuel pressure<br>• Lack of fuel<br>• Mass air flow sensor<br>• Incorrect PCV hose connection |
| P0174   | Fuel injection system too lean (bank 2) |   |  |

#### DTC CONFIRMATION PROCEDURE

##### 1. PRECONDITIONING

If DTC Confirmation Procedure has been previously conducted, always perform the following procedure before conducting the next test.

1. Turn ignition switch OFF and wait at least 10 seconds.
2. Turn ignition switch ON.
3. Turn ignition switch OFF and wait at least 10 seconds.

>> GO TO 2.

##### 2. PERFORM DTC CONFIRMATION PROCEDURE-I

1. Clear the mixture ratio self-learning value. Refer to [EC-662. "Work Procedure"](#).
2. Start engine.

Is it difficult to start engine?

- YES >> GO TO 3.  
NO >> GO TO 4.

##### 3. RESTART ENGINE

If it is difficult to start engine, the fuel injection system has a malfunction, too.  
Crank engine while depressing accelerator pedal.

#### NOTE:

When depressing accelerator pedal three fourths (3/4) or more, the control system does not start the engine.  
Do not depress accelerator pedal too much.

Does engine start?

- YES >> Go to [EC-755. "Diagnosis Procedure"](#).  
NO >> Check exhaust and intake air leak visually.

##### 4. PERFORM DTC CONFIRMATION PROCEDURE-II

1. Keep engine idle for at least 5 minutes.
2. Check 1st trip DTC.

Is 1st trip DTC detected?

# P0171, P0174 FUEL INJECTION SYSTEM FUNCTION

< DTC/CIRCUIT DIAGNOSIS >

[VQ37VHR FOR MEXICO]

- YES >> Go to [EC-755. "Diagnosis Procedure"](#).  
 NO >> GO TO 5.

## 5. PERFORM DTC CONFIRMATION PROCEDURE-III

- Turn ignition switch OFF and wait at least 10 seconds.
- Start engine.
- Maintain the following conditions for at least 10 consecutive minutes.  
Hold the accelerator pedal as steady as possible.

|               |                             |
|---------------|-----------------------------|
| VHCL SPEED SE | 50 - 120 km/h (31 - 75 MPH) |
|---------------|-----------------------------|

**CAUTION:**

**Always drive vehicle at a safe speed.**

- Check 1st trip DTC.

Is 1st trip DTC detected?

- YES >> Go to [EC-755. "Diagnosis Procedure"](#).  
 NO >> INSPECTION END

## Diagnosis Procedure

INFOID:000000007729847

### 1. CHECK EXHAUST GAS LEAK

- Start engine and run it at idle.
- Listen for an exhaust gas leak before three way catalyst 1.

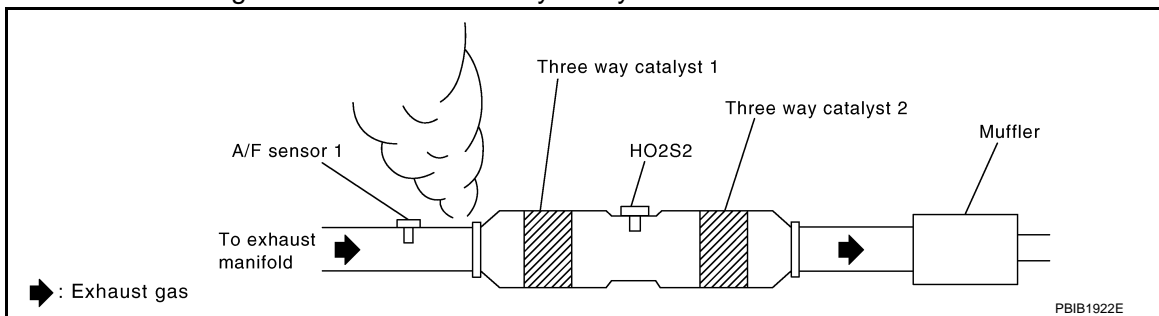

Is exhaust gas leak detected?

- YES >> Repair or replace.  
 NO >> GO TO 2.

### 2. CHECK FOR INTAKE AIR LEAK

- Listen for an intake air leak after the mass air flow sensor.
- Check PCV hose connection.

Is intake air leak detected?

- YES >> Repair or replace.  
 NO >> GO TO 3.

### 3. CHECK A/F SENSOR 1 INPUT SIGNAL CIRCUIT

- Turn ignition switch OFF.
- Disconnect corresponding A/F sensor 1 harness connector.
- Disconnect ECM harness connector.
- Check the continuity between A/F sensor 1 harness connector and ECM harness connector.

| DTC   | A/F sensor 1 |           |          | ECM       |          | Continuity |
|-------|--------------|-----------|----------|-----------|----------|------------|
|       | Bank         | Connector | Terminal | Connector | Terminal |            |
| P0171 | 1            | F74       | 1        | F102      | 57       | Existed    |
|       |              |           | 2        |           | 61       |            |
| P0174 | 2            | F75       | 1        |           | 65       |            |
|       |              |           | 2        |           | 66       |            |

# P0171, P0174 FUEL INJECTION SYSTEM FUNCTION

[VQ37VHR FOR MEXICO]

< DTC/CIRCUIT DIAGNOSIS >

5. Check the continuity between A/F sensor 1 harness connector and ground, or ECM harness connector and ground.

| DTC   | A/F sensor 1 |           |          | Ground | Continuity  |
|-------|--------------|-----------|----------|--------|-------------|
|       | Bank         | Connector | Terminal |        |             |
| P0171 | 1            | F74       | 1        | Ground | Not existed |
|       |              |           | 2        |        |             |
| P0174 | 2            | F75       | 1        |        |             |
|       |              |           | 2        |        |             |

| DTC   | ECM  |           |          | Ground | Continuity  |
|-------|------|-----------|----------|--------|-------------|
|       | Bank | Connector | Terminal |        |             |
| P0171 | 1    | F102      | 57       | Ground | Not existed |
|       |      |           | 61       |        |             |
| P0174 | 2    |           | 65       |        |             |
|       |      |           | 66       |        |             |

6. Also check harness for short to power.

Is the inspection result normal?

YES >> GO TO 4.

NO >> Repair open circuit, short to ground or short to power in harness or connectors.

## 4. CHECK FUEL PRESSURE

1. Release fuel pressure to zero. Refer to [EC-667, "Work Procedure"](#).
2. Install fuel pressure gauge and check fuel pressure. Refer to [EC-667, "Work Procedure"](#).

**At idling: Approximately 350 kPa (3.57 kg/cm<sup>2</sup>, 51 psi)**

Is the inspection result normal?

YES >> GO TO 6.

NO >> GO TO 5.

## 5. DETECT MALFUNCTIONING PART

Check fuel hoses and fuel tubes for clogging.

Is the inspection result normal?

YES >> Replace "fuel filter and fuel pump assembly". Refer to [FL-5, "Exploded View"](#).

NO >> Repair or replace.

## 6. CHECK MASS AIR FLOW SENSOR

 **With CONSULT**

1. Install all removed parts.
2. Check "MASS AIR FLOW" in "DATA MONITOR" mode with CONSULT.  
For specification, refer to [EC-982, "Mass Air Flow Sensor"](#).

 **With GST**

1. Install all removed parts.
2. Check mass air flow sensor signal in Service \$01 with GST.  
For specification, refer to [EC-982, "Mass Air Flow Sensor"](#).

Is the measurement value within the specification?

YES >> GO TO 7.

NO >> Check connectors for rusted terminals or loose connections in the mass air flow sensor circuit or grounds. Refer to [EC-706, "Diagnosis Procedure"](#).

## 7. CHECK FUNCTION OF FUEL INJECTOR

 **With CONSULT**

1. Start engine.

# P0171, P0174 FUEL INJECTION SYSTEM FUNCTION

[VQ37VHR FOR MEXICO]

## < DTC/CIRCUIT DIAGNOSIS >

2. Perform "POWER BALANCE" in "ACTIVE TEST" mode with CONSULT.
3. Make sure that each circuit produces a momentary engine speed drop.

### ⊗ Without CONSULT

1. Start engine and let it idle.
2. Listen to each fuel injector operating sound.

**Clicking sound should be heard.**

### Is the inspection result normal?

YES >> GO TO 8.

NO >> Perform trouble diagnosis for FUEL INJECTOR, refer to [EC-945. "Diagnosis Procedure"](#).

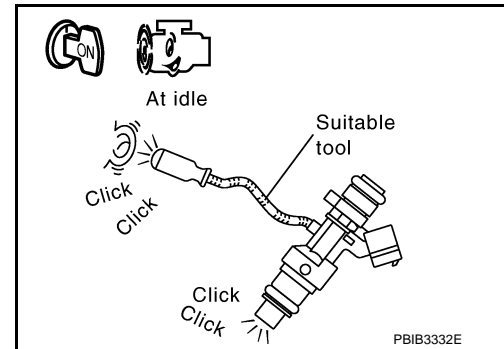

## 8. CHECK FUEL INJECTOR

1. Turn ignition switch OFF.
2. Confirm that the engine is cooled down and there are no fire hazards near the vehicle.
3. Disconnect all fuel injector harness connectors.
4. Remove fuel tube assembly. Refer to [EM-39. "Removal and Installation"](#).  
Keep fuel hose and all fuel injectors connected to fuel tube.
5. For DTC P0171, reconnect fuel injector harness connectors on bank 1.  
For DTC P0174, reconnect fuel injector harness connectors on bank 2.
6. Disconnect all ignition coil harness connectors.
7. Prepare pans or saucers under each fuel injector.
8. Crank engine for about 3 seconds.  
For DTC P0171, make sure that fuel sprays out from fuel injectors on bank 1.  
For DTC P0174, make sure that fuel sprays out from fuel injectors on bank 2.

**Fuel should be sprayed evenly for each fuel injector.**

### Is the inspection result normal?

YES >> GO TO 9.

NO >> Replace fuel injectors from which fuel does not spray out. Always replace O-ring with new ones.

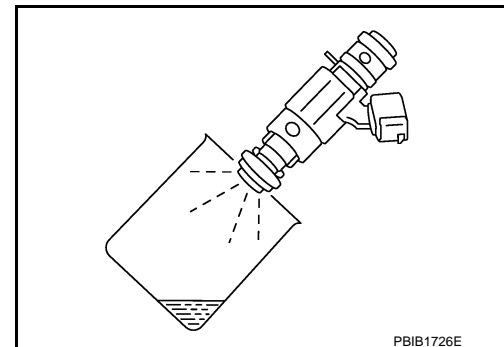

## 9. CHECK INTERMITTENT INCIDENT

Refer to [GI-44. "Intermittent Incident"](#).

>> INSPECTION END

# P0172, P0175 FUEL INJECTION SYSTEM FUNCTION

< DTC/CIRCUIT DIAGNOSIS >

[VQ37VHR FOR MEXICO]

## P0172, P0175 FUEL INJECTION SYSTEM FUNCTION

### DTC Logic

INFOID:000000007729848

#### DTC DETECTION LOGIC

With the Air/Fuel Mixture Ratio Self-Learning Control, the actual mixture ratio can be brought closely to the theoretical mixture ratio based on the mixture ratio feedback signal from A/F sensor 1. The ECM calculates the necessary compensation to correct the offset between the actual and the theoretical ratios.

In case the amount of the compensation value is extremely large (the actual mixture ratio is too rich), the ECM judges the condition as the fuel injection system malfunction and illuminates the MIL (2 trip detection logic).

| Sensor       | Input signal to ECM   | ECM function           | Actuator      |
|--------------|---|------------------------|---------------|
| A/F sensor 1 | Density of oxygen in exhaust gas<br>(Mixture ratio feedback signal) | Fuel injection control | Fuel injector |

| DTC No. | Trouble diagnosis name                  | DTC detecting condition  | Possible cause  |
|---------|---|--|---|
| P0172   | Fuel injection system too rich (bank 1) | • Fuel injection system does not operate properly.<br>• The amount of mixture ratio compensation is too large.<br>(The mixture ratio is too rich.) | • A/F sensor 1<br>• Fuel injector<br>• Exhaust gas leaks<br>• Incorrect fuel pressure<br>• Mass air flow sensor |
| P0175   | Fuel injection system too rich (bank 2) |  |   |

#### DTC CONFIRMATION PROCEDURE

##### 1. PRECONDITIONING

If DTC Confirmation Procedure has been previously conducted, always perform the following procedure before conducting the next test.

1. Turn ignition switch OFF and wait at least 10 seconds.
2. Turn ignition switch ON.
3. Turn ignition switch OFF and wait at least 10 seconds.

>> GO TO 2.

##### 2. PERFORM DTC CONFIRMATION PROCEDURE-I

1. Clear the mixture ratio self-learning value. Refer to [EC-662, "Work Procedure"](#).
2. Start engine.

Is it difficult to start engine?

- YES >> GO TO 3.  
NO >> GO TO 4.

##### 3. RESTART ENGINE

If it is difficult to start engine, the fuel injection system has a malfunction, too.

Crank engine while depressing accelerator pedal.

#### NOTE:

When depressing accelerator pedal three fourths (3/4) or more, the control system does not start the engine. Do not depress accelerator pedal too much.

Does engine start?

- YES >> Go to [EC-759, "Diagnosis Procedure"](#).  
NO >> Remove spark plugs and check for fouling, etc.

##### 4. PERFORM DTC CONFIRMATION PROCEDURE-II

1. Keep engine idle for at least 10 minutes.
2. Check 1st trip DTC.

Is 1st trip DTC detected?

- YES >> Go to [EC-759, "Diagnosis Procedure"](#).  
NO >> GO TO 5.

##### 5. PERFORM DTC CONFIRMATION PROCEDURE-III

# P0172, P0175 FUEL INJECTION SYSTEM FUNCTION

[VQ37VHR FOR MEXICO]

## < DTC/CIRCUIT DIAGNOSIS >

1. Turn ignition switch OFF and wait at least 10 seconds.
2. Start engine.
3. Maintain the following conditions for at least 10 consecutive minutes.  
Hold the accelerator pedal as steady as possible.

|               |                             |
|---------------|-----------------------------|
| VHCL SPEED SE | 50 - 120 km/h (31 - 75 MPH) |
|---------------|-----------------------------|

### CAUTION:

**Always drive vehicle at a safe speed.**

4. Check 1st trip DTC.

Is 1st trip DTC detected?

- YES >> Go to [EC-759, "Diagnosis Procedure"](#).  
NO >> INSPECTION END

## Diagnosis Procedure

INFOID:000000007729849

### 1. CHECK EXHAUST GAS LEAK

1. Start engine and run it at idle.
2. Listen for an exhaust gas leak before three way catalyst 1.

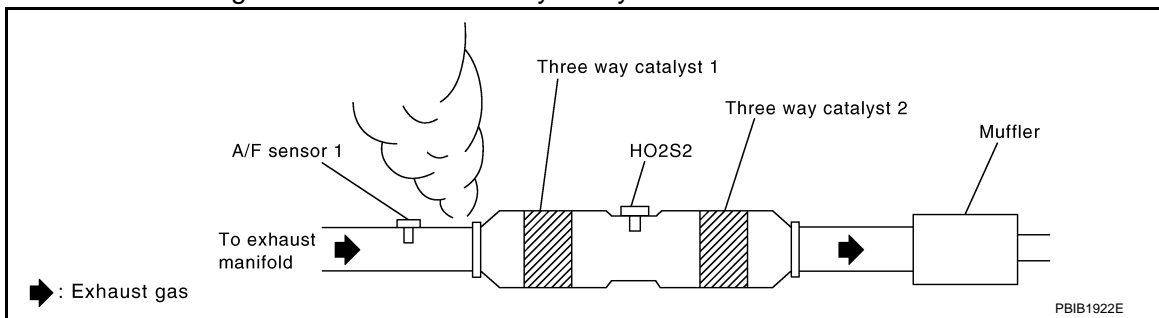

Is exhaust gas leak detected?

- YES >> Repair or replace.  
NO >> GO TO 2.

### 2. CHECK FOR INTAKE AIR LEAK

Listen for an intake air leak after the mass air flow sensor.

Is intake air leak detected?

- YES >> Repair or replace.  
NO >> GO TO 3.

### 3. CHECK A/F SENSOR 1 INPUT SIGNAL CIRCUIT

1. Turn ignition switch OFF.
2. Disconnect corresponding A/F sensor 1 harness connector.
3. Disconnect ECM harness connector.
4. Check the continuity between A/F sensor 1 harness connector and ECM harness connector.

| DTC   | A/F sensor 1 |           |          | ECM       |          | Continuity |
|-------|--------------|-----------|----------|-----------|----------|------------|
|       | Bank         | Connector | Terminal | Connector | Terminal |            |
| P0172 | 1            | F74       | 1        | F102      | 57       | Existed    |
|       |              |           | 2        |           | 61       |            |
| P0175 | 2            | F75       | 1        |           | 65       |            |
|       |              |           | 2        |           | 66       |            |

5. Check the continuity between A/F sensor 1 harness connector and ground, or ECM harness connector and ground.

# P0172, P0175 FUEL INJECTION SYSTEM FUNCTION

< DTC/CIRCUIT DIAGNOSIS >

[VQ37VHR FOR MEXICO]

| DTC   | A/F sensor 1 |           |          | Ground | Continuity  |
|-------|--------------|-----------|----------|--------|-------------|
|       | Bank         | Connector | Terminal |        |             |
| P0172 | 1            | F74       | 1        | Ground | Not existed |
|       |              |           | 2        |        |             |
| P0175 | 2            | F75       | 1        |        |             |
|       |              |           | 2        |        |             |

| DTC   | ECM  |           |          | Ground | Continuity  |
|-------|------|-----------|----------|--------|-------------|
|       | Bank | Connector | Terminal |        |             |
| P0172 | 1    | F102      | 57       | Ground | Not existed |
|       |      |           | 61       |        |             |
| P0175 | 2    |           | 65       |        |             |
|       |      |           | 66       |        |             |

6. Also check harness for short to power.

Is the inspection result normal?

YES >> GO TO 4.

NO >> Repair open circuit, short to ground or short to power in harness or connectors.

## 4.CHECK FUEL PRESSURE

1. Release fuel pressure to zero. Refer to [EC-667, "Work Procedure"](#).

2. Install fuel pressure gauge and check fuel pressure. Refer to [EC-667, "Work Procedure"](#).

**At idling: Approximately 350 kPa (3.57 kg/cm<sup>2</sup>, 51 psi)**

Is the inspection result normal?

YES >> GO TO 5.

NO >> Replace "fuel filter and fuel pump assembly". Refer to [FL-5, "Exploded View"](#).

## 5.CHECK MASS AIR FLOW SENSOR

### With CONSULT

1. Install all removed parts.

2. Check "MASS AIR FLOW" in "DATA MONITOR" mode with CONSULT.  
For specification, refer to [EC-982, "Mass Air Flow Sensor"](#).

### With GST

1. Install all removed parts.

2. Check mass air flow sensor signal in "Service \$01" with GST.  
For specification, refer to [EC-982, "Mass Air Flow Sensor"](#).

Is the measurement value within the specification?

YES >> GO TO 6.

NO >> Check connectors for rusted terminals or loose connections in the mass air flow sensor circuit or grounds. Refer to [EC-706, "Diagnosis Procedure"](#).

## 6.CHECK FUNCTION OF FUEL INJECTOR

### With CONSULT

1. Start engine.

2. Perform "POWER BALANCE" in "ACTIVE TEST" mode with CONSULT.

3. Make sure that each circuit produces a momentary engine speed drop.

### Without CONSULT

1. Start engine and let it idle.



# P0172, P0175 FUEL INJECTION SYSTEM FUNCTION

[VQ37VHR FOR MEXICO]

< DTC/CIRCUIT DIAGNOSIS >

- Listen to each fuel injector operating sound.

**Clicking sound should be heard.**

Is the inspection result normal?

YES >> GO TO 7.

NO >> Perform trouble diagnosis for FUEL INJECTOR, refer to [EC-945. "Diagnosis Procedure"](#).

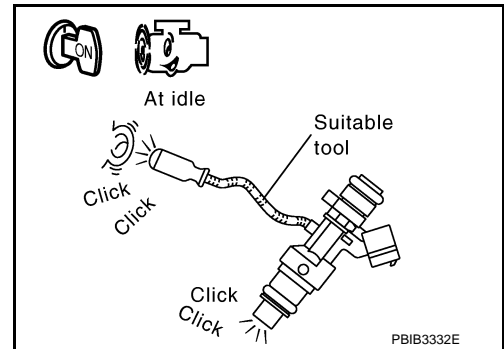

## 7. CHECK FUEL INJECTOR

- Remove fuel injector assembly. Refer to [EM-39. "Removal and Installation"](#).  
Keep fuel hose and all fuel injectors connected to fuel tube.
- Confirm that the engine is cooled down and there are no fire hazards near the vehicle.
- Disconnect all fuel injector harness connectors.
- Disconnect all ignition coil harness connectors.
- Prepare pans or saucers under each fuel injector.
- Crank engine for about 3 seconds.  
Make sure fuel that does not drip from fuel injector.

Is the inspection result normal?

YES >> GO TO 8.

NO >> Replace the fuel injectors from which fuel is dripping. Always replace O-ring with new one.

## 8. CHECK INTERMITTENT INCIDENT

Refer to [GI-44. "Intermittent Incident"](#).

>> INSPECTION END

# P0182, P0183 FTT SENSOR

< DTC/CIRCUIT DIAGNOSIS >

[VQ37VHR FOR MEXICO]

## P0182, P0183 FTT SENSOR

### DTC Logic

INFOID:000000007729857

### DTC DETECTION LOGIC

| DTC No. | Trouble diagnosis name                          | DTC detecting condition                                     | Possible cause  |
|---------|---|---|---|
| P0182   | Fuel tank temperature sensor circuit low input  | An excessively low voltage from the sensor is sent to ECM.  | <ul style="list-style-type: none"><li>• Harness or connectors (The sensor circuit is open or shorted.)</li><li>• Fuel tank temperature sensor</li></ul> |
| P0183   | Fuel tank temperature sensor circuit high input | An excessively high voltage from the sensor is sent to ECM. |   |

### DTC CONFIRMATION PROCEDURE

#### 1. PRECONDITIONING

If DTC Confirmation Procedure has been previously conducted, always perform the following procedure before conducting the next test.

1. Turn ignition switch OFF and wait at least 10 seconds.
2. Turn ignition switch ON.
3. Turn ignition switch OFF and wait at least 10 seconds.

>> GO TO 2.

#### 2. PERFORM DTC CONFIRMATION PROCEDURE

1. Turn ignition switch ON and wait at least 5 seconds.
2. Check 1st trip DTC.

Is 1st trip DTC detected?

- YES >> Go to [EC-762, "Diagnosis Procedure"](#).  
NO >> INSPECTION END

### Diagnosis Procedure

INFOID:000000007729858

#### 1. CHECK GROUND CONNECTION

1. Turn ignition switch OFF.
2. Check ground connection M95. Refer to Ground Inspection in [GI-47, "Circuit Inspection"](#).

Is the inspection result normal?

- YES >> GO TO 2.  
NO >> Repair or replace ground connection.

#### 2. CHECK DTC WITH "COMBINATION METER"

Refer to [MWI-31, "CONSULT Function"](#).

Is the inspection result normal?

- YES >> GO TO 3.  
NO >> Go to [MWI-62, "Component Function Check"](#).

#### 3. CHECK FUEL TANK TEMPERATURE SENSOR POWER SUPPLY CIRCUIT

1. Turn ignition switch OFF.
2. Disconnect "fuel level sensor unit and fuel pump" harness connector.
3. Turn ignition switch ON.
4. Check the voltage between "fuel level sensor unit and fuel pump" harness connector and ground.

| Fuel level sensor unit and fuel pump |          | Ground | Voltage (V) |
|--------------------------------------|----------|--------|-------------|
| Connector                            | Terminal |        |             |
| B241                                 | 4        | Ground | Approx. 5   |

Is the inspection result normal?

# P0182, P0183 FTT SENSOR

[VQ37VHR FOR MEXICO]

< DTC/CIRCUIT DIAGNOSIS >

- YES >> GO TO 5.
- NO >> GO TO 4.

## 4. DETECT MALFUNCTIONING PART

Check the following.

- Harness connectors M117, B201
- Harness for open or short between ECM and “fuel level sensor unit and fuel pump”

>> Repair open circuit, short to ground or short to power in harness or connector.

## 5. CHECK FUEL TANK TEMPERATURE SENSOR GROUND CIRCUIT FOR OPEN AND SHORT

1. Turn ignition switch OFF.
2. Disconnect “combination meter” harness connector.
3. Check the continuity between “fuel level sensor unit and fuel pump” harness connector and “combination meter” harness connector.

| Fuel level sensor unit and fuel pump |          | Combination meter |          | Continuity |
|--------------------------------------|----------|-------------------|----------|------------|
| Connector                            | Terminal | Connector         | Terminal |            |
| B241                                 | 5        | M53               | 24       | Existed    |

4. Also check harness for short to ground and short to power.

Is the inspection result normal?

- YES >> GO TO 7.
- NO >> GO TO 6.

## 6. DETECT MALFUNCTIONING PART

Check the following.

- Harness connectors M117, B201
- Harness for open or short between “fuel level sensor unit and fuel pump” and “combination meter”

>> Repair open circuit, short to ground or short to power in harness or connector.

## 7. CHECK FUEL TANK TEMPERATURE SENSOR

Refer to [EC-763, "Component Inspection"](#).

Is the inspection result normal?

- YES >> GO TO 8.
- NO >> Replace “fuel level sensor unit and fuel pump”. Refer to [FL-5, "Exploded View"](#).

## 8. CHECK INTERMITTENT INCIDENT

Refer to [GI-44, "Intermittent Incident"](#).

>> INSPECTION END

## Component Inspection

INFOID:000000007729859

## 1. CHECK FUEL TANK TEMPERATURE SENSOR

1. Turn ignition switch OFF.
2. Disconnect “fuel level sensor unit and fuel pump” harness connector.
3. Remove fuel level sensor unit. Refer to [FL-5, "Exploded View"](#).

# P0182, P0183 FTT SENSOR

[VQ37VHR FOR MEXICO]

## < DTC/CIRCUIT DIAGNOSIS >

4. Check resistance between "fuel level sensor unit and fuel pump" terminals by heating with hot water as shown in the figure.

| Terminals | Condition                                   | Resistance (k $\Omega$ ) |             |
|-----------|---|--------------------------|-------------|
| 4 and 5   | Temperature [ $^{\circ}$ C ( $^{\circ}$ F)] | 20 (68)                  | 2.3 - 2.7   |
|           |   | 50 (122)                 | 0.79 - 0.90 |

Is the inspection result normal?

YES >> INSPECTION END

NO >> Replace "fuel level sensor unit and fuel pump". Refer to [FL-5. "Exploded View"](#).

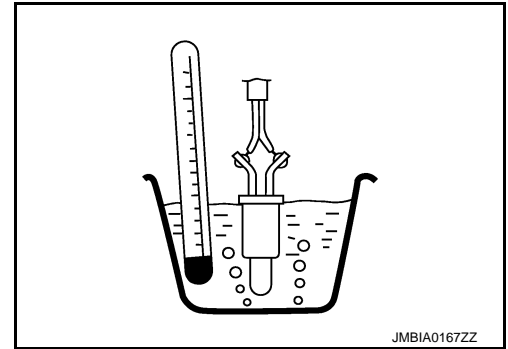

# P0197, P0198 EOT SENSOR

< DTC/CIRCUIT DIAGNOSIS >

[VQ37VHR FOR MEXICO]

## P0197, P0198 EOT SENSOR

### DTC Logic

INFOID:000000007729867

### DTC DETECTION LOGIC

| DTC No. | Trouble Diagnosis Name                           | DTC Detecting Condition                                     | Possible Cause  |
|---------|--|---|---|
| P0197   | Engine oil temperature sensor circuit low input  | An excessively low voltage from the sensor is sent to ECM.  | <ul style="list-style-type: none"> <li>• Harness or connectors (The sensor circuit is open or shorted.)</li> <li>• Engine oil temperature sensor</li> </ul> |
| P0198   | Engine oil temperature sensor circuit high input | An excessively high voltage from the sensor is sent to ECM. |   |

### DTC CONFIRMATION PROCEDURE

#### 1. PRECONDITIONING

If DTC Confirmation Procedure has been previously conducted, always perform the following procedure before conducting the next test.

1. Turn ignition switch OFF and wait at least 10 seconds.
2. Turn ignition switch ON.
3. Turn ignition switch OFF and wait at least 10 seconds.

>> GO TO 2.

#### 2. PERFORM DTC CONFIRMATION PROCEDURE

1. Start engine and wait at least 5 seconds.
2. Check 1st trip DTC.

Is 1st trip DTC detected?

- YES >> Go to [EC-765, "Diagnosis Procedure"](#).  
 NO >> INSPECTION END

### Diagnosis Procedure

INFOID:000000007729868

#### 1. CHECK GROUND CONNECTION

1. Turn ignition switch OFF.
2. Check ground connection M95. Refer to Ground Inspection in [GI-47, "Circuit Inspection"](#).

Is the inspection result normal?

- YES >> GO TO 2.  
 NO >> Repair or replace ground connection.

#### 2. CHECK EOT SENSOR POWER SUPPLY CIRCUIT

1. Disconnect engine oil temperature (EOT) sensor harness connector.
2. Turn ignition switch ON.
3. Check the voltage between EOT sensor harness connector and ground.

| EOT sensor |          | Ground | Voltage (V) |
|------------|----------|--------|-------------|
| Connector  | Terminal |        |             |
| F38        | 1        | Ground | Approx. 5   |

Is the inspection result normal?

- YES >> GO TO 3.  
 NO >> Repair open circuit, short to ground or short to power in harness or connectors.

#### 3. CHECK EOT SENSOR GROUND CIRCUIT FOR OPEN AND SHORT

1. Turn ignition switch OFF.
2. Disconnect ECM harness connector.
3. Check the continuity between EOT sensor harness connector and ECM harness connector.

# P0197, P0198 EOT SENSOR

< DTC/CIRCUIT DIAGNOSIS >

[VQ37VHR FOR MEXICO]

| EOT sensor |          | ECM       |          | Continuity |
|------------|----------|-----------|----------|------------|
| Connector  | Terminal | Connector | Terminal |            |
| F38        | 2        | F102      | 84       | Existed    |

4. Also check harness for short to ground and short to power.

Is the inspection result normal?

YES >> GO TO 4.

NO >> Repair open circuit, short to ground or short to power in harness or connectors.

## 4.CHECK ENGINE OIL TEMPERATURE SENSOR

Refer to [EC-766. "Component Inspection"](#).

Is the inspection result normal?

YES >> GO TO 5.

NO >> Replace engine oil temperature sensor. Refer to [EM-45. "Exploded View"](#).

## 5.CHECK INTERMITTENT INCIDENT

Refer to [GI-44. "Intermittent Incident"](#).

>> INSPECTION END

## Component Inspection

INFOID:000000007729869

## 1.CHECK ENGINE OIL TEMPERATURE SENSOR

1. Turn ignition switch OFF.
2. Disconnect engine oil temperature sensor harness connector.
3. Remove engine oil temperature sensor. Refer to [EM-45. "Exploded View"](#).
4. Check resistance between engine oil temperature sensor terminals by heating with hot water as shown in the figure.

| Terminals | Condition            | Resistance (kΩ) |               |
|-----------|----------------------|-----------------|---------------|
| 1 and 2   | Temperature °C (°F)] | 20 (68)         | 2.10 - 2.90   |
|           |                      | 50 (122)        | 0.68 - 1.00   |
|           |                      | 90 (194)        | 0.236 - 0.260 |

Is the inspection result normal?

YES >> INSPECTION END

NO >> Replace engine oil temperature sensor. Refer to [EM-45. "Exploded View"](#).

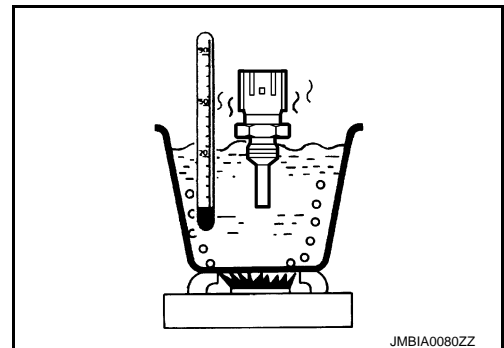

# P0222, P0223, P2132, P2133 TP SENSOR

< DTC/CIRCUIT DIAGNOSIS >

[VQ37VHR FOR MEXICO]

## P0222, P0223, P2132, P2133 TP SENSOR

### DTC Logic

INFOID:000000007729870

#### DTC DETECTION LOGIC

##### NOTE:

If DTC P0222, P0223, P2132 or P2133 is displayed with DTC P0643, first perform the trouble diagnosis for DTC P0643. Refer to [EC-822, "DTC Logic"](#).

| DTC No. | Trouble diagnosis name                                 | DTC detecting condition  | Possible cause  |
|---------|--|--|---|
| P0222   | Throttle position sensor 1 (bank 1) circuit low input  | An excessively low voltage from the TP sensor 1 is sent to ECM.  | • Harness or connectors (TP sensor 1 circuit is open or shorted.)<br>• Electric throttle control actuator (TP sensor 1) |
| P0223   | Throttle position sensor 1 (bank 1) circuit high input | An excessively high voltage from the TP sensor 1 is sent to ECM. |   |
| P2132   | Throttle position sensor 1 (bank 2) circuit low input  | An excessively low voltage from the TP sensor 1 is sent to ECM.  |   |
| P2133   | Throttle position sensor 1 (bank 2) circuit high input | An excessively high voltage from the TP sensor 1 is sent to ECM. |   |

#### DTC CONFIRMATION PROCEDURE

##### 1. PRECONDITIONING

If DTC Confirmation Procedure has been previously conducted, always perform the following procedure before conducting the next test.

1. Turn ignition switch OFF and wait at least 10 seconds.
2. Turn ignition switch ON.
3. Turn ignition switch OFF and wait at least 10 seconds.

##### TESTING CONDITION:

Before performing the following procedure, confirm that battery voltage is more than 10 V at idle.

>> GO TO 2.

##### 2. PERFORM DTC CONFIRMATION PROCEDURE

1. Start engine and let it idle for 1 second.
2. Check DTC.

Is DTC detected?

- YES >> Go to [EC-767, "Diagnosis Procedure"](#).  
NO >> INSPECTION END

#### Diagnosis Procedure

INFOID:000000007729871

##### 1. CHECK GROUND CONNECTION

1. Turn ignition switch OFF.
2. Check ground connection M95. Refer to Ground Inspection in [GI-47, "Circuit Inspection"](#).

Is the inspection result normal?

- YES >> GO TO 2.  
NO >> Repair or replace ground connection.

##### 2. CHECK THROTTLE POSITION SENSOR 1 POWER SUPPLY CIRCUIT

1. Disconnect electric throttle control actuator harness connector.
2. Turn ignition switch ON.
3. Check the voltage between electric throttle control actuator harness connector and ground.

## P0222, P0223, P2132, P2133 TP SENSOR

< DTC/CIRCUIT DIAGNOSIS >

[VQ37VHR FOR MEXICO]

| DTC          | Electric throttle control actuator |           |          | Ground | Voltage (V) |
|--------------|------------------------------------|-----------|----------|--------|-------------|
|              | Bank                               | Connector | Terminal |        |             |
| P0222, P0223 | 1                                  | F67       | 6        | Ground | Approx. 5   |
| P2132, P2133 | 2                                  | F27       | 1        |        |             |

Is the inspection result normal?

YES >> GO TO 3.

NO >> Repair open circuit, short to ground or short to power in harness or connectors.

### 3. CHECK THROTTLE POSITION SENSOR 1 GROUND CIRCUIT FOR OPEN AND SHORT

1. Turn ignition switch OFF.
2. Disconnect ECM harness connector.
3. Check the continuity between electric throttle control actuator harness connector and ECM harness connector.

| DTC          | Electric throttle control actuator |           |          | ECM       |          | Continuity |
|--------------|------------------------------------|-----------|----------|-----------|----------|------------|
|              | Bank                               | Connector | Terminal | Connector | Terminal |            |
| P0222, P0223 | 1                                  | F67       | 3        | F101      | 40       | Existed    |
| P2132, P2133 | 2                                  | F27       | 4        |           | 48       |            |

4. Also check harness for short to ground and short to power.

Is the inspection result normal?

YES >> GO TO 4.

NO >> Repair open circuit, short to ground or short to power in harness or connectors.

### 4. CHECK THROTTLE POSITION SENSOR 1 INPUT SIGNAL CIRCUIT FOR OPEN AND SHORT

1. Check the continuity between electric throttle control actuator harness connector and ECM harness connector.

| DTC          | Electric throttle control actuator |           |          | ECM       |          | Continuity |
|--------------|------------------------------------|-----------|----------|-----------|----------|------------|
|              | Bank                               | Connector | Terminal | Connector | Terminal |            |
| P0222, P0223 | 1                                  | F67       | 4        | F101      | 30       | Existed    |
| P2132, P2133 | 2                                  | F27       | 2        |           | 31       |            |

2. Also check harness for short to ground and short to power.

Is the inspection result normal?

YES >> GO TO 5.

NO >> Repair open circuit, short to ground or short to power in harness or connectors.

### 5. CHECK THROTTLE POSITION SENSOR

Refer to [EC-769, "Component Inspection"](#).

Is the inspection result normal?

YES >> GO TO 7.

NO >> GO TO 6.

### 6. REPLACE ELECTRIC THROTTLE CONTROL ACTUATOR

1. Replace malfunctioning electric throttle control actuator.
2. Go to [EC-769, "Special Repair Requirement"](#).

>> INSPECTION END

### 7. CHECK INTERMITTENT INCIDENT

Refer to [GI-44, "Intermittent Incident"](#).

>> INSPECTION END



# P0222, P0223, P2132, P2133 TP SENSOR

< DTC/CIRCUIT DIAGNOSIS >

[VQ37VHR FOR MEXICO]

INFOID:000000007729872

## Component Inspection

### 1. CHECK THROTTLE POSITION SENSOR

1. Turn ignition switch OFF.
2. Reconnect all harness connectors disconnected.
3. Perform [EC-657, "Work Procedure"](#).
4. Turn ignition switch ON.
5. Set selector lever to D position.
6. Check the voltage between ECM harness connector terminals under the following conditions.

| Connector | ECM                       |    | Condition       | Voltage (V)    |
|-----------|---------------------------|----|-----------------|----------------|
|           | +                         | -  |                 |                |
|           | Terminal                  |    |                 |                |
| F101      | 30 [TP sensor 1 (bank 1)] | 40 | Fully released  | More than 0.36 |
|           |                           |    | Fully depressed | Less than 4.75 |
|           | 31 [TP sensor 1 (bank 2)] | 48 | Fully released  | More than 0.36 |
|           |                           |    | Fully depressed | Less than 4.75 |
|           | 34 [TP sensor 2 (bank 1)] | 40 | Fully released  | Less than 4.75 |
|           |                           |    | Fully depressed | More than 0.36 |
|           | 35 [TP sensor 2 (bank 2)] | 48 | Fully released  | Less than 4.75 |
|           |                           |    | Fully depressed | More than 0.36 |

Is the inspection result normal?

YES >> INSPECTION END

NO >> GO TO 2.

### 2. REPLACE ELECTRIC THROTTLE CONTROL ACTUATOR

1. Replace malfunctioning electric throttle control actuator.
2. Go to [EC-769, "Special Repair Requirement"](#).

>> INSPECTION END

## Special Repair Requirement

INFOID:000000007729873

### 1. PERFORM THROTTLE VALVE CLOSED POSITION LEARNING

Refer to [EC-657, "Work Procedure"](#)

>> GO TO 2.

### 2. PERFORM IDLE AIR VOLUME LEARNING

Refer to [EC-658, "Work Procedure"](#)

>> END

# P0300, P0301, P0302, P0303, P0304, P0305, P0306 MISFIRE

< DTC/CIRCUIT DIAGNOSIS >

[VQ37VHR FOR MEXICO]

## P0300, P0301, P0302, P0303, P0304, P0305, P0306 MISFIRE

### DTC Logic

INFOID:000000007729874

#### DTC DETECTION LOGIC

When a misfire occurs, engine speed will fluctuate. If the engine speed fluctuates enough to cause the crankshaft position (CKP) sensor (POS) signal to vary, ECM can determine that a misfire is occurring.

| Sensor                           | Input signal to ECM | ECM function                  |
|----------------------------------|---------------------|-------------------------------|
| Crankshaft position sensor (POS) | Engine speed        | On board diagnosis of misfire |

The misfire detection logic consists of the following two conditions.

- One Trip Detection Logic (Three Way Catalyst Damage)**  
On the 1st trip, when a misfire condition occurs that can damage the three way catalyst (TWC) due to overheating, the MIL will blink.  
When a misfire condition occurs, the ECM monitors the CKP sensor signal every 200 engine revolutions for a change.  
When the misfire condition decreases to a level that will not damage the TWC, the MIL will turn off.  
If another misfire condition occurs that can damage the TWC on a second trip, the MIL will blink.  
When the misfire condition decreases to a level that will not damage the TWC, the MIL will remain illuminating.  
If another misfire condition occurs that can damage the TWC, the MIL will begin to blink again.
- Two Trip Detection Logic (Exhaust quality deterioration)**  
For misfire conditions that will not damage the TWC (but will affect vehicle emissions), the MIL will only illuminate when the misfire is detected on a second trip. During this condition, the ECM monitors the CKP sensor signal every 1,000 engine revolutions.  
A misfire malfunction can be detected in any one cylinder or in multiple cylinders.

| DTC No. | Trouble diagnosis name              | DTC detecting condition     | Possible cause  |
|---------|-------------------------------------|-----------------------------|---|
| P0300   | Multiple cylinder misfires detected | Multiple cylinders misfire. | <ul style="list-style-type: none"><li>• Improper spark plug</li><li>• Insufficient compression</li><li>• Incorrect fuel pressure</li><li>• The fuel injector circuit is open or shorted</li><li>• Fuel injector</li><li>• Intake air leak</li><li>• The ignition signal circuit is open or shorted</li><li>• Lack of fuel</li><li>• Signal plate</li><li>• A/F sensor 1</li><li>• Incorrect PCV hose connection</li></ul> |
| P0301   | No.1 cylinder misfire detected      | No. 1 cylinder misfires.    |   |
| P0302   | No. 2 cylinder misfire detected     | No. 2 cylinder misfires.    |   |
| P0303   | No. 3 cylinder misfire detected     | No. 3 cylinder misfires.    |   |
| P0304   | No. 4 cylinder misfire detected     | No. 4 cylinder misfires.    |   |
| P0305   | No. 5 cylinder misfire detected     | No. 5 cylinder misfires.    |   |
| P0306   | No. 6 cylinder misfire detected     | No. 6 cylinder misfires.    |   |

#### DTC CONFIRMATION PROCEDURE

##### 1. PRECONDITIONING

If DTC Confirmation Procedure has been previously conducted, always perform the following procedure before conducting the next test.

1. Turn ignition switch OFF and wait at least 10 seconds.
2. Turn ignition switch ON.
3. Turn ignition switch OFF and wait at least 10 seconds.

>> GO TO 2.

##### 2. PERFORM DTC CONFIRMATION PROCEDURE-I

1. Start engine and warm it up to normal operating temperature.
2. Turn ignition switch OFF and wait at least 10 seconds.
3. Turn ignition switch ON.
4. Turn ignition switch OFF and wait at least 10 seconds.
5. Restart engine and let it idle for about 15 minutes.
6. Check 1st trip DTC.

Is 1st trip DTC detected?

# P0300, P0301, P0302, P0303, P0304, P0305, P0306 MISFIRE

< DTC/CIRCUIT DIAGNOSIS >

[VQ37VHR FOR MEXICO]

- YES >> Go to [EC-771. "Diagnosis Procedure"](#).  
NO >> GO TO 3.

## 3.PERFORM DTC CONFIRMATION PROCEDURE-II

1. Turn ignition switch OFF and wait at least 10 seconds.
2. Turn ignition switch ON.
3. Turn ignition switch OFF and wait at least 10 seconds.
4. Start engine and drive the vehicle under similar conditions to (1st trip) Freeze Frame Data for a certain time. Refer to the table below.

**Hold the accelerator pedal as steady as possible.**

Similar conditions to (1st trip) Freeze Frame Data mean that the following conditions should be satisfied at the same time.

**CAUTION:**

**Always drive vehicle in safe manner according to traffic conditions and obey all traffic laws when driving.**

|  |  |
|--|--|
| Engine speed                             | Engine speed in the freeze frame data $\pm$ 400 rpm  |
| Vehicle speed                            | Vehicle speed in the freeze frame data $\pm$ 10 km/h (6 MPH)   |
| Base fuel schedule                       | Base fuel schedule in the freeze frame data $\times$ (1 $\pm$ 0.1)   |
| Engine coolant temperature (T) condition | When the freeze frame data shows lower than 70 °C (158 °F), T should be lower than 70 °C (158 °F).                           |
|  | When the freeze frame data shows higher than or equal to 70 °C (158 °F), T should be higher than or equal to 70 °C (158 °F). |

Driving time varies according to the engine speed in the freeze frame data.

| Engine speed        | Time                      |
|---------------------|---------------------------|
| Around 1,000 rpm    | Approximately 10 minutes  |
| Around 2,000 rpm    | Approximately 5 minutes   |
| More than 3,000 rpm | Approximately 3.5 minutes |

5. Check 1st trip DTC.

Is 1st trip DTC detected?

- YES >> Go to [EC-771. "Diagnosis Procedure"](#).  
NO >> INSPECTION END

## Diagnosis Procedure

INFOID:000000007729875

### 1.CHECK FOR INTAKE AIR LEAK AND PCV HOSE

1. Start engine and run it at idle speed.
2. Listen for the sound of the intake air leak.
3. Check PCV hose connection.

Is intake air leak detected?

- YES >> Discover air leak location and repair.  
NO >> GO TO 2.

### 2.CHECK FOR EXHAUST SYSTEM CLOGGING

Stop engine and visually check exhaust tube, three way catalyst and muffler for dents.

Is the inspection result normal?

- YES-1 >> With CONSULT: GO TO 3.  
YES-2 >> Without CONSULT: GO TO 4.  
NO >> Repair or replace it.

### 3.PERFORM POWER BALANCE TEST

 **With CONSULT**

1. Start engine.
2. Perform "POWER BALANCE" in "ACTIVE TEST" mode with CONSULT.

## P0300, P0301, P0302, P0303, P0304, P0305, P0306 MISFIRE

[VQ37VHR FOR MEXICO]

### < DTC/CIRCUIT DIAGNOSIS >

3. Make sure that each circuit produces a momentary engine speed drop.

Is the inspection result normal?

YES >> GO TO 9.

NO >> GO TO 4.

### 4. CHECK FUNCTION OF FUEL INJECTOR-I

1. Start engine and let it idle.
2. Listen to each fuel injector operation sound.

**Clicking sound should be heard.**

Is the inspection result normal?

YES >> GO TO 5.

NO >> Perform trouble diagnosis for FUEL INJECTOR, refer to [EC-945, "Diagnosis Procedure"](#).

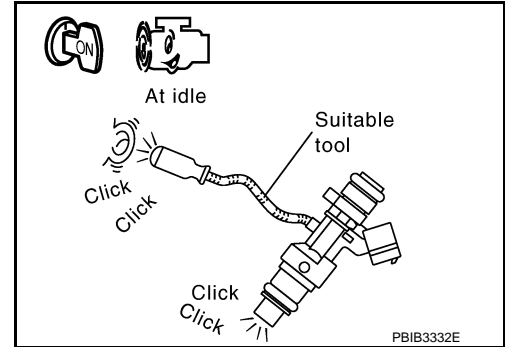

### 5. CHECK FUNCTION OF IGNITION COIL-I

#### CAUTION:

Perform the following procedure in a place where with no combustible objects and good ventilation.

1. Turn ignition switch OFF.
2. Remove fuel pump fuse (1) in IPDM E/R (2) to release fuel pressure.

#### NOTE:

Do not use CONSULT to release fuel pressure, or fuel pressure applies again during the following procedure.

3. Start engine.
4. After engine stalls, crank it two or three times to release all fuel pressure.
5. Turn ignition switch OFF.
6. Remove all ignition coil harness connectors to avoid the electrical discharge from the ignition coils.
7. Remove ignition coil and spark plug of the cylinder to be checked.
8. Crank engine for 5 seconds or more to remove combustion gas in the cylinder.
9. Connect spark plug and harness connector to ignition coil.
10. Fix ignition coil using a rope etc. with gap of 13 - 17 mm (0.52 - 0.66 in) between the edge of the spark plug and grounded metal portion as shown in the figure.
11. Crank engine for about 3 seconds, and check whether spark is generated between the spark plug and the grounded metal portion.

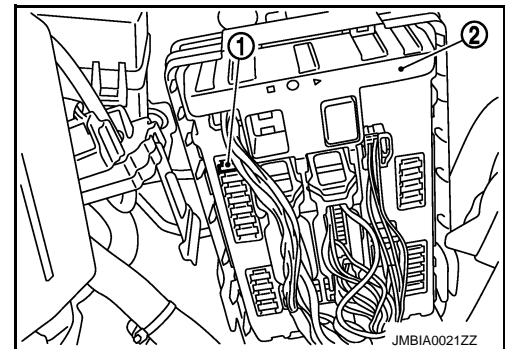

**Spark should be generated.**

#### CAUTION:

- Never place the spark plug and the ignition coil within 50 cm (19.7 in) each other. Be careful not to get an electrical shock while checking, because the electrical discharge voltage becomes 20 kV or more.
- It might damage the ignition coil if the gap of more than 17 mm (0.66 in) is made.

#### NOTE:

When the gap is less than 13 mm (0.52 in), a spark might be generated even if the coil is malfunctioning.

Is the inspection result normal?

YES >> GO TO 9.

NO >> GO TO 6.

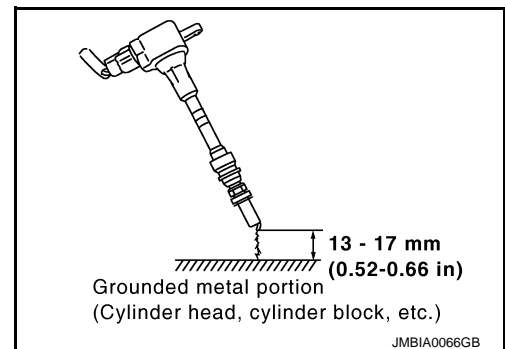

**6. CHECK FUNCTION OF IGNITION COIL-II**

1. Turn ignition switch OFF.
2. Disconnect spark plug and connect a non-malfunctioning spark plug.
3. Crank engine for about 3 seconds, and recheck whether spark is generated between the spark plug and the grounded metal portion.

**Spark should be generated.**

Is the inspection result normal?

YES >> GO TO 7.

NO >> Check ignition coil, power transistor and their circuits. Refer to [EC-952. "Diagnosis Procedure"](#).

**7. CHECK SPARK PLUG**

Check the initial spark plug for fouling, etc.

Is the inspection result normal?

YES >> Replace spark plug(s) with standard type one(s). For spark plug type, refer to [EM-26. "Inspection"](#).

NO >> Repair or clean spark plug. Then GO TO 8.

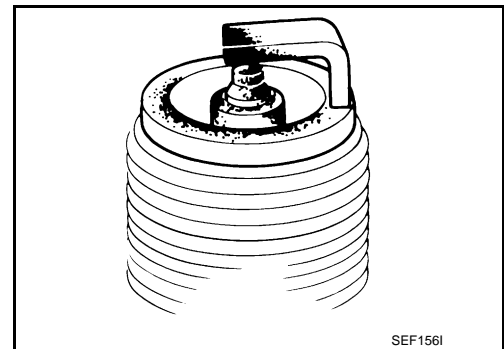

**8. CHECK FUNCTION OF IGNITION COIL-III**

1. Reconnect the initial spark plugs.
2. Crank engine for about 3 seconds, and recheck whether spark is generated between the spark plug and the grounded portion.

**Spark should be generated.**

Is the inspection result normal?

YES >> INSPECTION END

NO >> Replace spark plug(s) with standard type one(s). For spark plug type, refer to [EM-25. "Removal and Installation"](#).

**9. CHECK COMPRESSION PRESSURE**

Check compression pressure. Refer to [EM-18. "Inspection"](#).

Is the inspection result normal?

YES >> GO TO 10.

NO >> Check pistons, piston rings, valves, valve seats and cylinder head gaskets.

**10. CHECK FUEL PRESSURE**

1. Install all removed parts.
2. Release fuel pressure to zero. Refer to [EC-667. "Work Procedure"](#).
3. Install fuel pressure gauge and check fuel pressure. Refer to [EC-667. "Work Procedure"](#).

**At idle: Approximately 350 kPa (3.57 kg/cm<sup>2</sup>, 51 psi)**

Is the inspection result normal?

YES >> GO TO 12.

NO >> GO TO 11.

**11. DETECT MALFUNCTIONING PART**

Check fuel hoses and fuel tubes for clogging.

Is the inspection result normal?

YES >> Replace "fuel filter and fuel pump assembly".

NO >> Repair or replace.

# P0300, P0301, P0302, P0303, P0304, P0305, P0306 MISFIRE

< DTC/CIRCUIT DIAGNOSIS >

[VQ37VHR FOR MEXICO]

## 12. CHECK IDLE SPEED AND IGNITION TIMING

For procedure, refer to [EC-663, "Work Procedure"](#).

For specification, refer to [EC-982, "Idle Speed"](#) and [EC-982, "Ignition Timing"](#).

Is the inspection result normal?

YES >> GO TO 13.

NO >> Follow the [EC-663, "Work Procedure"](#).

## 13. CHECK A/F SENSOR 1 INPUT SIGNAL CIRCUIT

1. Turn ignition switch OFF.
2. Disconnect corresponding A/F sensor 1 harness connector.
3. Disconnect ECM harness connector.
4. Check the continuity between A/F sensor 1 harness connector and ECM harness connector.

| A/F sensor 1 |           |          | ECM       |          | Continuity |
|--------------|-----------|----------|-----------|----------|------------|
| Bank         | Connector | Terminal | Connector | Terminal |            |
| 1            | F74       | 1        | F102      | 57       | Existed    |
|              |           | 2        |           | 61       |            |
| 2            | F75       | 1        |           | 65       |            |
|              |           | 2        |           | 66       |            |

5. Check the continuity between A/F sensor 1 harness connector and ground, or ECM harness connector and ground.

| A/F sensor 1 |           |          | Ground | Continuity  |
|--------------|-----------|----------|--------|-------------|
| Bank         | Connector | Terminal |        |             |
| 1            | F74       | 1        | Ground | Not existed |
|              |           | 2        |        |             |
| 2            | F75       | 1        |        |             |
|              |           | 2        |        |             |

| ECM  |           |          | Ground | Continuity  |
|------|-----------|----------|--------|-------------|
| Bank | Connector | Terminal |        |             |
| 1    | F102      | 57       | Ground | Not existed |
|      |           | 61       |        |             |
| 65   |           |          |        |             |
| 66   |           |          |        |             |
| 2    |           |          |        |             |

6. Also check harness for short to power.

Is the inspection result normal?

YES >> GO TO 14.

NO >> Repair open circuit, short to ground or short to power in harness or connectors.

## 14. CHECK A/F SENSOR 1 HEATER

Refer to [EC-699, "Component Inspection"](#).

Is the inspection result normal?

YES >> GO TO 15.

NO >> Replace (malfunctioning) A/F sensor 1. Refer to [EM-36, "Exploded View"](#).

## 15. CHECK MASS AIR FLOW SENSOR

### With CONSULT

Check mass air flow sensor signal in "DATA MONITOR" mode with CONSULT.

For specification, refer to [EC-982, "Mass Air Flow Sensor"](#).

### With GST

# P0300, P0301, P0302, P0303, P0304, P0305, P0306 MISFIRE

[VQ37VHR FOR MEXICO]

< DTC/CIRCUIT DIAGNOSIS >

Check mass air flow sensor signal in Service \$01 with GST.

For specification, refer to [EC-982, "Mass Air Flow Sensor"](#).

Is the measurement value within the specification?

YES >> GO TO 16.

NO >> Check connectors for rusted terminals or loose connections in the mass air flow sensor circuit or ground. Refer to [EC-706, "Diagnosis Procedure"](#).

## 16.CHECK SYMPTOM TABLE

Check items on the rough idle symptom in [EC-969, "Symptom Table"](#).

Is the inspection result normal?

YES >> GO TO 17.

NO >> Repair or replace.

## 17.ERASE THE 1ST TRIP DTC

Some tests may cause a 1st trip DTC to be set.

Erase the 1st trip DTC from the ECM memory after performing the tests. Refer to [EC-598, "On Board Diagnosis Function"](#) (Without CONSULT) or [EC-601, "CONSULT Function"](#) (With CONSULT).

>> GO TO 18.

## 18.CHECK INTERMITTENT INCIDENT

Refer to [GI-44, "Intermittent Incident"](#).

>> INSPECTION END

A  
EC  
C  
D  
E  
F  
G  
H  
I  
J  
K  
L  
M  
N  
O  
P

P0327, P0328, P0332, P0333 KS

DTC Logic

INFOID:000000007729876

DTC DETECTION LOGIC

| DTC No. | Trouble diagnosis name                   | DTC detected condition                                      | Possible cause   |
|---------|--|---|--|
| P0327   | Knock sensor (bank 1) circuit low input  | An excessively low voltage from the sensor is sent to ECM.  | <ul style="list-style-type: none"> <li>• Harness or connectors (The sensor circuit is open or shorted.)</li> <li>• Knock sensor</li> </ul> |
| P0328   | Knock sensor (bank 1) circuit high input | An excessively high voltage from the sensor is sent to ECM. |  |
| P0332   | Knock sensor (bank 2) circuit low input  | An excessively low voltage from the sensor is sent to ECM.  |  |
| P0333   | Knock sensor (bank 2) circuit high input | An excessively high voltage from the sensor is sent to ECM. |  |

DTC CONFIRMATION PROCEDURE

1. PRECONDITIONING

If DTC Confirmation Procedure has been previously conducted, always perform the following procedure before conducting the next test.

1. Turn ignition switch OFF and wait at least 10 seconds.
2. Turn ignition switch ON.
3. Turn ignition switch OFF and wait at least 10 seconds.

**TESTING CONDITION:**

**Before performing the following procedure, confirm that battery voltage is more than 10 V at idle.**

>> GO TO 2.

2. PERFORM DTC CONFIRMATION PROCEDURE

1. Start engine and run it for at least 5 seconds at idle speed.
2. Check 1st trip DTC.

Is 1st trip DTC detected?

- YES >> Go to [EC-776, "Diagnosis Procedure"](#).  
 NO >> INSPECTION END

Diagnosis Procedure

INFOID:000000007729877

1. CHECK GROUND CONNECTION

1. Turn ignition switch OFF.
2. Check ground connection M95. Refer to Ground Inspection in [GI-47, "Circuit Inspection"](#).

Is the inspection result normal?

- YES >> GO TO 2.  
 NO >> Repair or replace ground connection.

2. CHECK KNOCK SENSOR GROUND CIRCUIT FOR OPEN AND SHORT

1. Disconnect knock sensor harness connector and ECM harness connector.
2. Check the continuity between knock sensor harness connector and ECM harness connector.

| DTC          | Knock sensor |           |          | ECM       |          | Continuity |
|--------------|--------------|-----------|----------|-----------|----------|------------|
|              | Bank         | Connector | Terminal | Connector | Terminal |            |
| P0327, P0328 | 1            | F203      | 2        | F102      | 72       | Existed    |
| P0332, P0333 | 2            | F202      | 2        |           |          |            |

3. Also check harness for short to ground and short to power.

Is the inspection result normal?



< DTC/CIRCUIT DIAGNOSIS >

- YES >> GO TO 4.
- NO >> GO TO 3.

**3. DETECT MALFUNCTIONING PART**

Check the following.

- Harness connectors F9, F201
- Harness for open or short between knock sensor and ECM

>> Repair open circuit or short to power in harness or connectors.

**4. CHECK KNOCK SENSOR INPUT SIGNAL CIRCUIT FOR OPEN AND SHORT**

1. Check the continuity between knock sensor harness connector and ECM harness connector.

| DTC          | Knock sensor |           |          | ECM       |          | Continuity |
|--------------|--------------|-----------|----------|-----------|----------|------------|
|              | Bank         | Connector | Terminal | Connector | Terminal |            |
| P0327, P0328 | 1            | F203      | 1        | F102      | 73       | Existed    |
| P0332, P0333 | 2            | F202      | 1        |           | 69       |            |

2. Also check harness for short to ground and short to power.

Is the inspection result normal?

- YES >> GO TO 6.
- NO >> GO TO 5.

**5. DETECT MALFUNCTIONING PART**

Check the following.

- Harness connectors F9, F201
- Harness for open or short between ECM and knock sensor

>> Repair open circuit, short to ground or short to power in harness or connectors.

**6. CHECK KNOCK SENSOR**

Refer to [EC-777. "Component Inspection"](#).

Is the inspection result normal?

- YES >> GO TO 7.
- NO >> Replace malfunctioning knock sensor. Refer to [EM-123. "Exploded View"](#).

**7. CHECK INTERMITTENT INCIDENT**

Refer to [GI-44. "Intermittent Incident"](#).

>> INSPECTION END

**Component Inspection**

INFOID:0000000007729878

**1. CHECK KNOCK SENSOR**

1. Turn ignition switch OFF.
2. Disconnect knock sensor harness connector.
3. Check resistance between knock sensor terminals as per the following.

**NOTE:**

**It is necessary to use an ohmmeter which can measure more than 10 MΩ.**

| Terminals | Resistance (kΩ)                    |
|-----------|------------------------------------|
| 1 and 2   | Approx. 532 - 588 [at 20°C (68°F)] |

**CAUTION:**

**Do not use any knock sensors that have been dropped or physically damaged. Use only new ones.**

Is the inspection result normal?

- YES >> INSPECTION END

**P0327, P0328, P0332, P0333 KS**

< DTC/CIRCUIT DIAGNOSIS >

[VQ37VHR FOR MEXICO]

---

NO >> Replace malfunctioning knock sensor. Refer to [EM-123, "Exploded View"](#).

# P0335 CKP SENSOR (POS)

< DTC/CIRCUIT DIAGNOSIS >

[VQ37VHR FOR MEXICO]

## P0335 CKP SENSOR (POS)

### DTC Logic

INFOID:000000007729879

### DTC DETECTION LOGIC

| DTC No. | Trouble diagnosis name                   | DTC detecting condition   | Possible cause  |
|---------|--|---|---|
| P0335   | Crankshaft position sensor (POS) circuit | <ul style="list-style-type: none"><li>The crankshaft position sensor (POS) signal is not detected by the ECM during the first few seconds of engine cranking.</li><li>The proper pulse signal from the crankshaft position sensor (POS) is not sent to ECM while the engine is running.</li><li>The crankshaft position sensor (POS) signal is not in the normal pattern during engine running.</li></ul> | <ul style="list-style-type: none"><li>Harness or connectors [CKP sensor (POS) circuit is open or shorted.] [CMP sensor (PHASE) (bank 2) circuit is open or shorted.] (APP sensor 2 circuit is shorted.) (EVAP control system pressure sensor circuit is shorted.) (Battery current sensor circuit is shorted.) (Refrigerant pressure sensor circuit is shorted.)</li><li>Crankshaft position sensor (POS)</li><li>Camshaft position sensor (PHASE) (bank 2)</li><li>Accelerator pedal position sensor</li><li>EVAP control system pressure sensor</li><li>Battery current sensor</li><li>Refrigerant pressure sensor</li><li>Signal plate</li></ul> |

### DTC CONFIRMATION PROCEDURE

#### 1. PRECONDITIONING

If DTC Confirmation Procedure has been previously conducted, always perform the following procedure before conducting the next test.

- Turn ignition switch OFF and wait at least 10 seconds.
- Turn ignition switch ON.
- Turn ignition switch OFF and wait at least 10 seconds.

#### TESTING CONDITION:

Before performing the following procedure, confirm that battery voltage is more than 10.5 V with ignition switch ON.

>> GO TO 2.

#### 2. PERFORM DTC CONFIRMATION PROCEDURE

- Start engine and let it idle for at least 5 seconds.  
If engine does not start, crank engine for at least 2 seconds.
- Check 1st trip DTC.

Is 1st trip DTC detected?

- YES >> Go to [EC-779, "Diagnosis Procedure"](#).  
NO >> INSPECTION END

### Diagnosis Procedure

INFOID:000000007729880

#### 1. CHECK GROUND CONNECTION

- Turn ignition switch OFF.
- Check ground connection M95. Refer to Ground Inspection in [GI-47, "Circuit Inspection"](#).

Is the inspection result normal?

- YES >> GO TO 2.  
NO >> Repair or replace ground connection.

#### 2. CHECK CRANKSHAFT POSITION (CKP) SENSOR (POS) POWER SUPPLY CIRCUIT-I

- Disconnect crankshaft position (CKP) sensor (POS) harness connector.
- Turn ignition switch ON.
- Check the voltage between CKP sensor (POS) harness connector and ground.

# P0335 CKP SENSOR (POS)

< DTC/CIRCUIT DIAGNOSIS >

[VQ37VHR FOR MEXICO]

| CKP sensor (POS) |          | Ground | Voltage (V) |
|------------------|----------|--------|-------------|
| Connector        | Terminal |        |             |
| F2               | 1        | Ground | Approx. 5   |

Is the inspection result normal?

YES >> GO TO 8.

NO >> GO TO 3.

## 3. CHECK CRANKSHAFT POSITION (CKP) SENSOR (POS) POWER SUPPLY CIRCUIT-II

1. Turn ignition switch ON.
2. Disconnect ECM harness connector.
3. Check the continuity between CKP sensor (POS) harness connector and ECM harness connector.

| CKP sensor (POS) |          | ECM       |          | Continuity |
|------------------|----------|-----------|----------|------------|
| Connector        | Terminal | Connector | Terminal |            |
| F2               | 1        | F101      | 46       | Existed    |

Is the inspection result normal?

YES >> GO TO 4.

NO >> Repair open circuit.

## 4. CHECK SENSOR POWER SUPPLY CIRCUIT

Check harness for short to power and short to ground, between the following terminals.

| ECM       |          | Sensor                              |  |                                    |
|-----------|----------|-------------------------------------|--|------------------------------------|
| Connector | Terminal | Name                                | Connector                              | Terminal                           |
| F101      | 46       | CKP sensor (POS)                    | F2                                     | 1                                  |
| F102      | 64       | CMP sensor (PHASE) (bank 2)         | F18                                    | 1                                  |
|           |          | Battery current sensor              | E21                                    |                                    |
| M107      | 103      | APP sensor                          | M153 <sup>*1</sup><br>M9 <sup>*2</sup> | 3 <sup>*1</sup><br>6 <sup>*2</sup> |
|           | 107      | EVAP control system pressure sensor | B73                                    | 3                                  |
|           |          | Refrigerant pressure sensor         | E77                                    | 3                                  |

\*1: With ICC

\*2: Without ICC

Is the inspection result normal?

YES >> GO TO 5.

NO >> Repair short to ground or short to power in harness or connectors.

## 5. CHECK COMPONENTS

Check the following.

- Camshaft position sensor (PHASE) (bank 2) (Refer to [EC-786, "Component Inspection"](#).)
- Battery current sensor (Refer to [EC-870, "Component Inspection"](#).)
- Refrigerant pressure sensor (Refer to [EC-967, "Diagnosis Procedure"](#).)

Is the inspection result normal?

YES >> GO TO 6.

NO >> Replace malfunctioning component.

## 6. CHECK APP SENSOR

Refer to [EC-920, "Component Inspection"](#).

Is the inspection result normal?

YES >> GO TO 12.

NO >> GO TO 7.

# P0335 CKP SENSOR (POS)

< DTC/CIRCUIT DIAGNOSIS >

[VQ37VHR FOR MEXICO]

## 7. REPLACE ACCELERATOR PEDAL ASSEMBLY

1. Replace accelerator pedal assembly.
2. Go to [EC-920, "Special Repair Requirement"](#).

>> INSPECTION END

## 8. CHECK CKP SENSOR (POS) GROUND CIRCUIT FOR OPEN AND SHORT

1. Turn ignition switch OFF.
2. Disconnect ECM harness connector.
3. Check the continuity between CKP sensor (POS) harness connector and ECM harness connector.

| CKP sensor (POS) |          | ECM       |          | Continuity |
|------------------|----------|-----------|----------|------------|
| Connector        | Terminal | Connector | Terminal |            |
| F2               | 2        | F101      | 47       | Existed    |

4. Also check harness for short to ground and short to power.

Is the inspection result normal?

YES >> GO TO 9.

NO >> Repair open circuit, short to ground or short to power in harness or connectors.

## 9. CHECK CKP SENSOR (POS) INPUT SIGNAL CIRCUIT FOR OPEN AND SHORT

1. Check the continuity between CKP sensor (POS) harness connector and ECM harness connector.

| CKP sensor (POS) |          | ECM       |          | Continuity |
|------------------|----------|-----------|----------|------------|
| Connector        | Terminal | Connector | Terminal |            |
| F2               | 3        | F101      | 37       | Existed    |

2. Also check harness for short to ground and short to power.

Is the inspection result normal?

YES >> GO TO 10.

NO >> Repair open circuit, short to ground or short to power in harness or connectors.

## 10. CHECK CRANKSHAFT POSITION SENSOR (POS)

Refer to [EC-781, "Component Inspection"](#).

Is the inspection result normal?

YES >> GO TO 11.

NO >> Replace crankshaft position sensor (POS). Refer to [EM-123, "Exploded View"](#).

## 11. CHECK GEAR TOOTH

Visually check for chipping signal plate gear tooth.

Is the inspection result normal?

YES >> GO TO 12.

NO >> Replace the signal plate. Refer to [EM-123, "Exploded View"](#).

## 12. CHECK INTERMITTENT INCIDENT

Refer to [GI-44, "Intermittent Incident"](#).

>> INSPECTION END

## Component Inspection

INFOID:000000007729881

### 1. CHECK CRANKSHAFT POSITION SENSOR (POS)-I

1. Turn ignition switch OFF.
2. Loosen the fixing bolt of the sensor.
3. Disconnect crankshaft position sensor (POS) harness connector.
4. Remove the sensor. Refer to [EM-123, "Exploded View"](#).

## P0335 CKP SENSOR (POS)

[VQ37VHR FOR MEXICO]

< DTC/CIRCUIT DIAGNOSIS >

5. Visually check the sensor for chipping.

Is the inspection result normal?

YES >> GO TO 2.

NO >> Replace crankshaft position sensor (POS). Refer to [EM-123, "Exploded View"](#).

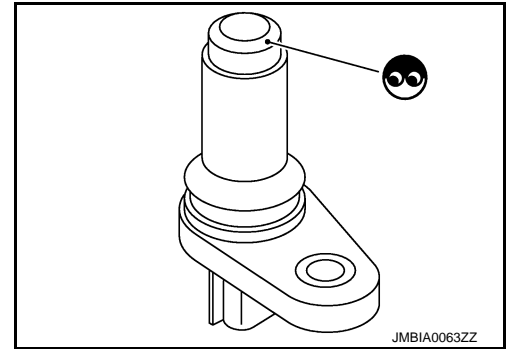

### 2. CHECK CRANKSHAFT POSITION SENSOR (POS)-II

Check resistance between crankshaft position sensor (POS) terminals as follows.

| Terminals (Polarity) | Resistance ( $\Omega$ )               |
|----------------------|---------------------------------------|
| 1 (+) - 2 (-)        | Except 0 or $\infty$ [at 25°C (77°F)] |
| 1 (+) - 3 (-)        |                                       |
| 2 (+) - 3 (-)        |                                       |

Is the inspection result normal?

YES >> INSPECTION END

NO >> Replace crankshaft position sensor (POS). Refer to [EM-123, "Exploded View"](#).

# P0340, P0345 CMP SENSOR (PHASE)

< DTC/CIRCUIT DIAGNOSIS >

[VQ37VHR FOR MEXICO]

## P0340, P0345 CMP SENSOR (PHASE)

### DTC Logic

INFOID:000000007729882

### DTC DETECTION LOGIC

#### NOTE:

If DTC P0340 or P0345 is displayed with DTC P0643, first perform the trouble diagnosis for DTC P0643. Refer to [EC-822, "DTC Logic"](#).

| DTC No. | Trouble diagnosis name                            | DTC detecting condition  | Possible cause  |
|---------|---|--|---|
| P0340   | Camshaft position sensor (PHASE) (bank 1) circuit |  | <ul style="list-style-type: none"> <li>• Harness or connectors [CMP sensor (PHASE) (bank 1) circuit is open or shorted.]</li> <li>• Camshaft position sensor (PHASE) (bank 1)</li> <li>• Camshaft (INT)</li> <li>• Starter motor</li> <li>• Starting system circuit</li> <li>• Dead (Weak) battery</li> </ul>   |
| P0345   | Camshaft position sensor (PHASE) (bank 2) circuit | <ul style="list-style-type: none"> <li>• The cylinder No. signal is not sent to ECM for the first few seconds during engine cranking.</li> <li>• The cylinder No. signal is not sent to ECM during engine running.</li> <li>• The cylinder No. signal is not in the normal pattern during engine running.</li> </ul> | <ul style="list-style-type: none"> <li>• Harness or connectors [CMP sensor (PHASE) (bank 2) circuit is open or shorted.] [CKP sensor (POS) circuit is open or shorted.] (APP sensor 2 circuit is shorted.) (EVAP control system pressure sensor circuit is shorted.) (Battery current sensor circuit is open or shorted.) (Refrigerant pressure sensor circuit is shorted.)</li> <li>• Camshaft position sensor (PHASE) (bank 2)</li> <li>• Crankshaft position sensor (POS)</li> <li>• Accelerator pedal position sensor</li> <li>• EVAP control system pressure sensor</li> <li>• Battery current sensor</li> <li>• Refrigerant pressure sensor</li> <li>• Camshaft (INT)</li> <li>• Starter motor</li> <li>• Starting system circuit</li> <li>• Dead (Weak) battery</li> </ul> |

### DTC CONFIRMATION PROCEDURE

#### 1. PRECONDITIONING

If DTC Confirmation Procedure has been previously conducted, always perform the following procedure before conducting the next test.

1. Turn ignition switch OFF and wait at least 10 seconds.
2. Turn ignition switch ON.
3. Turn ignition switch OFF and wait at least 10 seconds.

#### TESTING CONDITION:

Before performing the following procedure, confirm that battery voltage is more than 10.5 V with ignition switch ON.

>> GO TO 2.

#### 2. PERFORM DTC CONFIRMATION PROCEDURE-I

1. Start engine and let it idle for at least 5 seconds.  
If engine does not start, crank engine for at least 2 seconds.
2. Check 1st trip DTC.

Is 1st trip DTC detected?

YES >> Go to [EC-784, "Diagnosis Procedure"](#).

NO >> GO TO 3.

#### 3. PERFORM DTC CONFIRMATION PROCEDURE-II

1. Maintaining engine speed at more than 800 rpm for at least 5 seconds.
2. Check 1st trip DTC.

# P0340, P0345 CMP SENSOR (PHASE)

< DTC/CIRCUIT DIAGNOSIS >

[VQ37VHR FOR MEXICO]

Is 1st trip DTC detected?

- YES >> Go to [EC-784, "Diagnosis Procedure"](#).
- NO >> INSPECTION END

## Diagnosis Procedure

INFOID:000000007729883

### 1. CHECK STARTING SYSTEM

Turn ignition switch to START position.

Does the engine turn over? Does the starter motor operate?

- YES >> GO TO 2.
- NO >> Check starting system. (Refer to [ST-11, "Work Flow \(Heated Steering Wheel\)"](#)).

### 2. CHECK GROUND CONNECTION

1. Turn ignition switch OFF.
2. Check ground connection M95. Refer to Ground Inspection in [GI-47, "Circuit Inspection"](#).

Is the inspection result normal?

- YES >> GO TO 3.
- NO >> Repair or replace ground connection.

### 3. CHECK CAMSHAFT POSITION (CMP) SENSOR (PHASE) POWER SUPPLY CIRCUIT-I

1. Disconnect camshaft position (CMP) sensor (PHASE) harness connector.
2. Turn ignition switch ON.
3. Check the voltage between CMP sensor (PHASE) harness connector and ground.

| DTC   | CMP sensor (PHASE) |           |          | Ground | Voltage (V) |
|-------|--------------------|-----------|----------|--------|-------------|
|       | Bank               | Connector | Terminal |        |             |
| P0340 | 1                  | F5        | 1        | Ground | Approx. 5   |
| P0345 | 2                  | F18       | 1        |        |             |

Is the inspection result normal?

- YES >> GO TO 9.
- NO-1 >> P0340: Repair open circuit, short to ground or short to power in harness or connectors.
- NO-2 >> P0345: GO TO 4.

### 4. CHECK CAMSHAFT POSITION (CMP) SENSOR (PHASE) POWER SUPPLY CIRCUIT-II

1. Turn ignition switch OFF.
2. Disconnect ECM harness connector.
3. Check the continuity between CMP sensor (PHASE) harness connector and ECM harness connector.

| CMP sensor (PHASE) |           |          | ECM       |          | Continuity |
|--------------------|-----------|----------|-----------|----------|------------|
| Bank               | Connector | Terminal | Connector | Terminal |            |
| 2                  | F18       | 1        | F102      | 64       | Existed    |

Is the inspection result normal?

- YES >> GO TO 5.
- NO >> Repair open circuit.

### 5. CHECK CAMSHAFT POSITION (CMP) SENSOR (PHASE) POWER SUPPLY CIRCUIT-III

Check harness for short to power and short to ground, between the following terminals.

| ECM       |          | Sensor                      |           |          |
|-----------|----------|-----------------------------|-----------|----------|
| Connector | Terminal | Name                        | Connector | Terminal |
| F101      | 46       | CKP sensor (POS)            | F2        | 1        |
| F102      | 64       | CMP sensor (PHASE) (bank 2) | F18       | 1        |
|           |          | Battery current sensor      | E21       |          |



# P0340, P0345 CMP SENSOR (PHASE)

< DTC/CIRCUIT DIAGNOSIS >

[VQ37VHR FOR MEXICO]

| ECM       |          | Sensor                              |  |                                    |
|-----------|----------|-------------------------------------|--|------------------------------------|
| Connector | Terminal | Name                                | Connector                              | Terminal                           |
| M107      | 103      | APP sensor                          | M153 <sup>*1</sup><br>M9 <sup>*2</sup> | 3 <sup>*1</sup><br>6 <sup>*2</sup> |
|           |          | EVAP control system pressure sensor | B73                                    | 3                                  |
|           | 107      | Refrigerant pressure sensor         | E77                                    | 3                                  |

\*1: With ICC

\*2: Without ICC

Is the inspection result normal?

YES >> GO TO 6.

NO >> Repair short to ground or short to power in harness or connectors.

## 6. CHECK COMPONENTS

Check the following.

- Crankshaft position sensor (POS) (Refer to [EC-781, "Component Inspection"](#).)
- Battery current sensor (Refer to [EC-870, "Component Inspection"](#).)
- Refrigerant pressure sensor (Refer to [EC-967, "Diagnosis Procedure"](#).)

Is the inspection result normal?

YES >> GO TO 7.

NO >> Replace malfunctioning component.

## 7. CHECK APP SENSOR

Refer to [EC-920, "Component Inspection"](#).

Is the inspection result normal?

YES >> GO TO 13.

NO >> GO TO 8.

## 8. REPLACE ACCELERATOR PEDAL ASSEMBLY

1. Replace accelerator pedal assembly.
2. Go to [EC-920, "Special Repair Requirement"](#).

>> INSPECTION END

## 9. CHECK CMP SENSOR (PHASE) GROUND CIRCUIT FOR OPEN AND SHORT

1. Turn ignition switch OFF.
2. Disconnect ECM harness connector.
3. Check the continuity between CMP sensor (PHASE) harness connector and ECM harness connector.

| DTC   | CMP sensor (PHASE) |           |          | ECM       |          | Continuity |
|-------|--------------------|-----------|----------|-----------|----------|------------|
|       | Bank               | Connector | Terminal | Connector | Terminal |            |
| P0340 | 1                  | F5        | 2        | F102      | 96       | Existed    |
| P0345 | 2                  | F18       | 2        |           | 92       |            |

4. Also check harness for short to ground and short to power.

Is the inspection result normal?

YES >> GO TO 10.

NO >> Repair open circuit, short to ground or short to power in harness or connectors.

## 10. CHECK CMP SENSOR (PHASE) INPUT SIGNAL CIRCUIT FOR OPEN AND SHORT

1. Check the continuity between CMP sensor (PHASE) harness connector and ECM harness connector.

# P0340, P0345 CMP SENSOR (PHASE)

< DTC/CIRCUIT DIAGNOSIS >

[VQ37VHR FOR MEXICO]

| DTC   | CMP sensor (PHASE) |           |          | ECM       |          | Continuity |
|-------|--------------------|-----------|----------|-----------|----------|------------|
|       | Bank               | Connector | Terminal | Connector | Terminal |            |
| P0340 | 1                  | F5        | 3        | F102      | 59       | Existed    |
| P0345 | 2                  | F18       | 3        |           | 63       |            |

2. Also check harness for short to ground and short to power.

Is the inspection result normal?

YES >> GO TO 11.

NO >> Repair open circuit, short to ground or short to power in harness or connectors.

## 11. CHECK CAMSHAFT POSITION SENSOR (PHASE)

Refer to [EC-786, "Component Inspection"](#).

Is the inspection result normal?

YES >> GO TO 12.

NO >> Replace malfunctioning camshaft position sensor (PHASE). Refer to [EM-52, "Exploded View"](#).

## 12. CHECK CAMSHAFT (INTAKE)

Check the following.

- Accumulation of debris to the signal plate of camshaft front end
- Chipping signal plate of camshaft front end

Is the inspection result normal?

YES >> GO TO 13.

NO >> Remove debris and clean the signal plate of camshaft front end or replace camshaft.

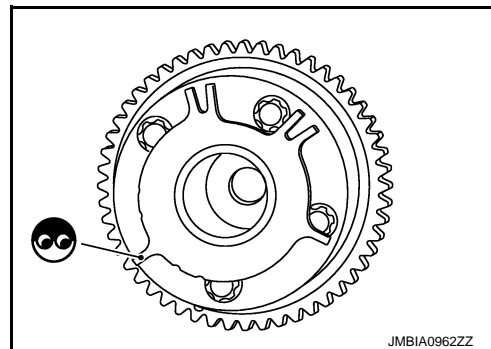

## 13. CHECK INTERMITTENT INCIDENT

Refer to [GI-44, "Intermittent Incident"](#).

>> INSPECTION END

## Component Inspection

INFOID:000000007729884

### 1. CHECK CAMSHAFT POSITION SENSOR (PHASE)-I

1. Turn ignition switch OFF.
2. Loosen the fixing bolt of the sensor.
3. Disconnect camshaft position sensor (PHASE) harness connector.
4. Remove the sensor. Refer to [EM-52, "Exploded View"](#).
5. Visually check the sensor for chipping.

Is the inspection result normal?

YES >> GO TO 2.

NO >> Replace malfunctioning camshaft position sensor (PHASE). Refer to [EM-52, "Exploded View"](#).

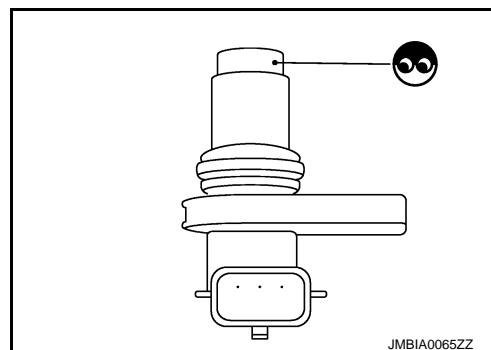

### 2. CHECK CAMSHAFT POSITION SENSOR (PHASE)-II

Check resistance camshaft position sensor (PHASE) terminals as follows.

# P0340, P0345 CMP SENSOR (PHASE)

< DTC/CIRCUIT DIAGNOSIS >

[VQ37VHR FOR MEXICO]

| Terminals (Polarity) | Resistance ( $\Omega$ )               |
|----------------------|---------------------------------------|
| 1 (+) - 2 (-)        | Except 0 or $\infty$ [at 25°C (77°F)] |
| 1 (+) - 3 (-)        |                                       |
| 2 (+) - 3 (-)        |                                       |

A

EC

Is the inspection result normal?

YES >> INSPECTION END

NO >> Replace malfunctioning camshaft position sensor (PHASE). Refer to [EM-52. "Exploded View"](#).

C

D

E

F

G

H

I

J

K

L

M

N

O

P

# P0420, P0430 THREE WAY CATALYST FUNCTION

< DTC/CIRCUIT DIAGNOSIS >

[VQ37VHR FOR MEXICO]

## P0420, P0430 THREE WAY CATALYST FUNCTION

### DTC Logic

INFOID:000000007729885

#### DTC DETECTION LOGIC

The ECM monitors the switching frequency ratio of air fuel ratio (A/F) sensor 1 and heated oxygen sensor 2. A three way catalyst 1 with high oxygen storage capacity will indicate a low switching frequency of heated oxygen sensor 2. As oxygen storage capacity decreases, the heated oxygen sensor 2 switching frequency will increase.

When the frequency ratio of A/F sensor 1 and heated oxygen sensor 2 approaches a specified limit value, the three way catalyst 1 malfunction is diagnosed.

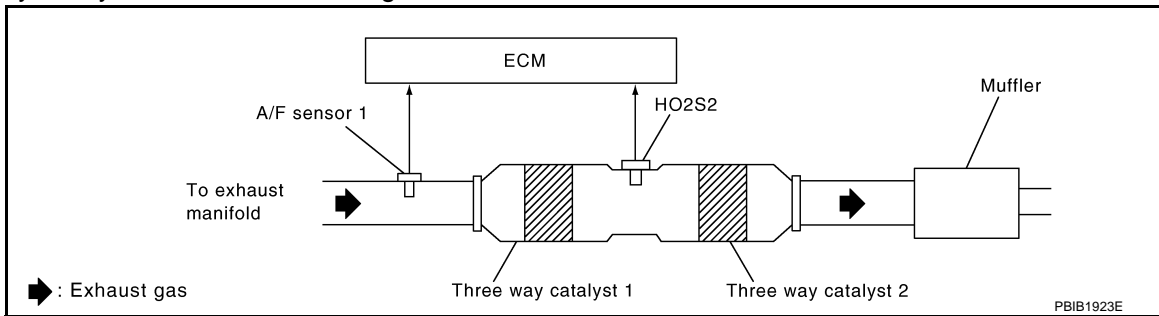

| DTC No. | Trouble diagnosis name                              | DTC detecting condition   | Possible cause  |
|---------|---|---|---|
| P0420   | Catalyst system efficiency below threshold (bank 1) | <ul style="list-style-type: none"> <li>Three way catalyst (manifold) does not operate properly.</li> <li>Three way catalyst (manifold) does not have enough oxygen storage capacity.</li> </ul> | <ul style="list-style-type: none"> <li>Three way catalyst (manifold)</li> <li>Exhaust tube</li> <li>Intake air leaks</li> <li>Fuel injector</li> <li>Fuel injector leaks</li> <li>Spark plug</li> <li>Improper ignition timing</li> </ul> |
| P0430   | Catalyst system efficiency below threshold (bank 2) |   |   |

### DTC CONFIRMATION PROCEDURE

#### 1. INSPECTION START

Do you have CONSULT?

Do you have CONSULT?

YES >> GO TO 2.

NO >> GO TO 7.

#### 2. PRECONDITIONING

If DTC Confirmation Procedure has been previously conducted, always perform the following procedure before conducting the next test.

1. Turn ignition switch OFF and wait at least 10 seconds.
2. Turn ignition switch ON.
3. Turn ignition switch OFF and wait at least 10 seconds.

#### TESTING CONDITION:

**Do not hold engine speed for more than the specified minutes below.**

>> GO TO 3.

#### 3. PERFORM DTC CONFIRMATION PROCEDURE-I

##### With CONSULT

1. Turn ignition switch ON and select "DATA MONITOR" mode with CONSULT.
2. Start engine and warm it up to the normal operating temperature.
3. Turn ignition switch OFF and wait at least 10 seconds.
4. Turn ignition switch ON.
5. Turn ignition switch OFF and wait at least 10 seconds.
6. Start engine and keep the engine speed between 3,500 and 4,000 rpm for at least 1 minute under no load.
7. Let engine idle for 1 minute.

# P0420, P0430 THREE WAY CATALYST FUNCTION

[VQ37VHR FOR MEXICO]

## < DTC/CIRCUIT DIAGNOSIS >

8. Make sure that "COOLAN TEMP/S" indicates more than 70°C (158°F).  
If not, warm up engine and go to next step when "COOLAN TEMP/S" indication reaches 70°C (158°F).
9. Open engine hood.
10. Select "DTC & SRT CONFIRMATION" then "SRT WORK SUPPORT" mode with CONSULT.
11. Rev engine up to about 2,000 rpm and hold it for 3 consecutive minutes then release the accelerator pedal completely.
12. Check the indication of "CATALYST".

Which is displayed on CONSULT screen?

- CMPLT >> GO TO 6.
- INCMP >> GO TO 4.

### 4.PERFORM DTC CONFIRMATION PROCEDURE-II

1. Wait 5 seconds at idle.
2. Rev engine up to about 2,000 rpm and maintain it until "INCMP" of "CATALYST" changes to "CMPLT" (It will take approximately 5 minutes).

Does the indication change to "CMPLT"?

- YES >> GO TO 6.
- NO >> GO TO 5.

### 5.PERFORM DTC CONFIRMATION PROCEDURE AGAIN

1. Stop engine and cool it down to less than 70°C (158°F).
2. Perform DTC CONFIRMATION PROCEDURE again.

>> GO TO 3.

### 6.PERFORM DTC CONFIRMATION PROCEDURE-III

Check 1st trip DTC.

Is 1st trip DTC detected?

- YES >> Go to [EC-790, "Diagnosis Procedure"](#).
- NO >> INSPECTION END

### 7.PERFORM COMPONENT FUNCTION CHECK

Perform component function check. Refer to [EC-789, "Component Function Check"](#).

#### NOTE:

Use component function check to check the overall function of the three way catalyst (manifold). During this check, a 1st trip DTC might not be confirmed.

Is the inspection result normal?

- YES >> INSPECTION END
- NO >> Go to [EC-790, "Diagnosis Procedure"](#).

## Component Function Check

INFOID:000000007729886

### 1.PERFORM COMPONENT FUNCTION CHECK

#### Without CONSULT

1. Start engine and warm it up to the normal operating temperature.
2. Turn ignition switch OFF and wait at least 10 seconds.
3. Start engine and keep the engine speed between 3,500 and 4,000 rpm for at least 1 minute under no load.
4. Let engine idle for 1 minute.
5. Open engine hood.
6. Check the voltage between ECM harness connector terminals under the following condition.

# P0420, P0430 THREE WAY CATALYST FUNCTION

< DTC/CIRCUIT DIAGNOSIS >

[VQ37VHR FOR MEXICO]

| DTC   | ECM       |                        |          | Condition  | Voltage  |
|-------|-----------|------------------------|----------|--|--|
|       | Connector | +                      | -        |  |  |
|       |           | Terminal               | Terminal |  |  |
| P0420 | F102      | 76<br>[HO2S2 (bank 1)] | 84       | Keeping engine speed at 2,500 rpm constant under no load | The voltage fluctuation cycle takes more than 5 seconds.<br>• 1 cycle: 0.6 - 1.0 → 0 - 0.3 → 0.6 - 1.0 |
| P0430 |           | 80<br>[HO2S2 (bank 2)] |          |  |  |

Is the inspection result normal?

YES >> INSPECTION END

NO >> Go to [EC-790, "Diagnosis Procedure"](#).

## Diagnosis Procedure

INFOID:000000007729887

### 1. CHECK EXHAUST SYSTEM

Visually check exhaust tubes and muffler for dents.

Is the inspection result normal?

YES >> GO TO 2.

NO >> Repair or replace.

### 2. CHECK EXHAUST GAS LEAK

1. Start engine and run it at idle.
2. Listen for an exhaust gas leak before the three way catalyst 1.

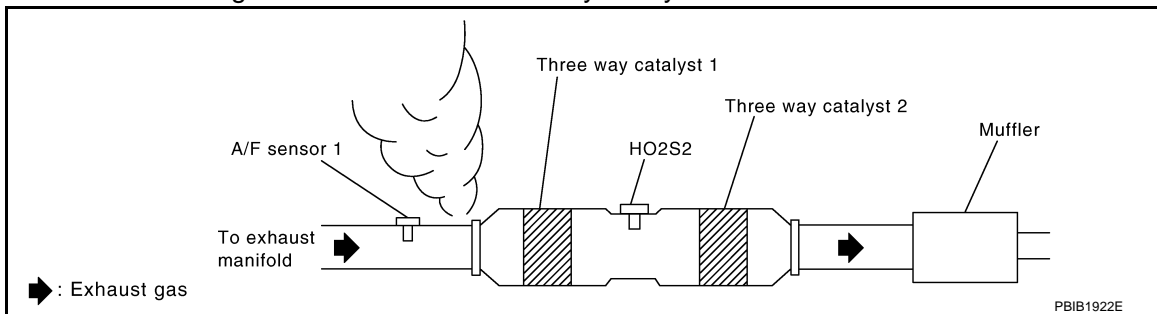

Is exhaust gas leak detected?

YES >> Repair or replace.

NO >> GO TO 3.

### 3. CHECK INTAKE AIR LEAK

Listen for an intake air leak after the mass air flow sensor.

Is intake air leak detected?

YES >> Repair or replace.

NO >> GO TO 4.

### 4. CHECK IDLE SPEED AND IGNITION TIMING

For procedure, refer to [EC-663, "Work Procedure"](#).

For specification, refer to [EC-982, "Idle Speed"](#) and [EC-982, "Ignition Timing"](#).

Is the inspection result normal?

YES >> GO TO 5.

NO >> Follow the [EC-663, "Work Procedure"](#).

### 5. CHECK FUEL INJECTORS

1. Stop engine and then turn ignition switch ON.
2. Check the voltage between ECM harness connector terminals as per the following.

# P0420, P0430 THREE WAY CATALYST FUNCTION

< DTC/CIRCUIT DIAGNOSIS >

[VQ37VHR FOR MEXICO]

| ECM       |          |           |          | Voltage         |
|-----------|----------|-----------|----------|-----------------|
| +         |          | -         |          |                 |
| Connector | Terminal | Connector | Terminal |                 |
| F102      | 81       | M107      | 128      | Battery voltage |
|           | 82       |           |          |                 |
|           | 85       |           |          |                 |
|           | 86       |           |          |                 |
|           | 89       |           |          |                 |
|           | 90       |           |          |                 |

Is the inspection result normal?

YES >> GO TO 6.

NO >> Perform [EC-945, "Diagnosis Procedure"](#).

## 6. CHECK FUNCTION OF IGNITION COIL-I

### CAUTION:

Perform the following procedure in a place where with no combustible objects and good ventilation.

1. Turn ignition switch OFF.
2. Remove fuel pump fuse (1) in IPDM E/R (2) to release fuel pressure.

### NOTE:

Do not use CONSULT to release fuel pressure, or fuel pressure applies again during the following procedure.

3. Start engine.
4. After engine stalls, crank it two or three times to release all fuel pressure.
5. Turn ignition switch OFF.
6. Remove all ignition coil harness connectors to avoid the electrical discharge from the ignition coils.
7. Remove ignition coil and spark plug of the cylinder to be checked.
8. Crank engine for 5 seconds or more to remove combustion gas in the cylinder.
9. Connect spark plug and harness connector to ignition coil.
10. Fix ignition coil using a rope etc. with gap of 13 - 17 mm (0.52 - 0.66 in) between the edge of the spark plug and grounded metal portion as shown in the figure.
11. Crank engine for about 3 seconds, and check whether spark is generated between the spark plug and the grounded metal portion.

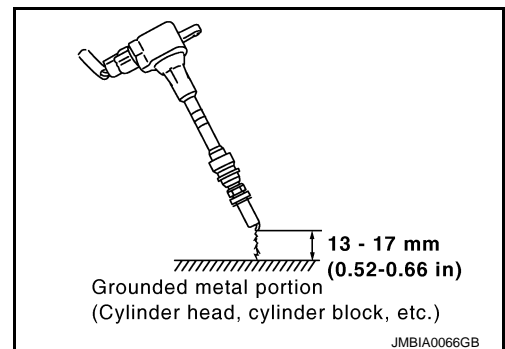
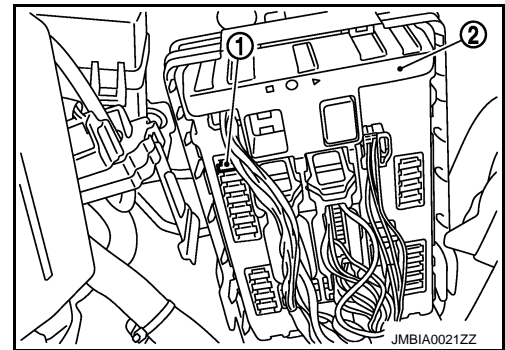

**Spark should be generated.**

### CAUTION:

- Never place the spark plug and the ignition coil within 50 cm (19.7 in) each other. Be careful not to get an electrical shock while checking, because the electrical discharge voltage becomes 20 kV or more.
- It might damage the ignition coil if the gap of more than 17 mm (0.66 in) is made.

### NOTE:

When the gap is less than 13 mm (0.52 in), a spark might be generated even if the coil is malfunctioning.

Is the inspection result normal?

YES >> GO TO 10.

NO >> GO TO 7.

## 7. CHECK FUNCTION OF IGNITION COIL-II

1. Turn ignition switch OFF.

## P0420, P0430 THREE WAY CATALYST FUNCTION

[VQ37VHR FOR MEXICO]

< DTC/CIRCUIT DIAGNOSIS >

2. Disconnect spark plug and connect a non-malfunctioning spark plug.
3. Crank engine for about 3 seconds, and recheck whether spark is generated between the spark plug and the grounded metal portion.

**Spark should be generated.**

Is the inspection result normal?

YES >> GO TO 8.

NO >> Check ignition coil, power transistor and their circuits. Refer to [EC-952. "Diagnosis Procedure"](#).

### 8.CHECK SPARK PLUG

Check the initial spark plug for fouling, etc.

Is the inspection result normal?

YES >> Replace spark plug(s) with standard type one(s). For spark plug type, refer to [EM-26. "Inspection"](#).

NO >> Repair or clean spark plug. Then GO TO 9.

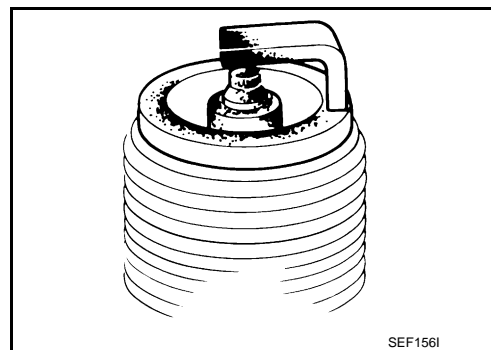

### 9.CHECK FUNCTION OF IGNITION COIL-III

1. Reconnect the initial spark plugs.
2. Crank engine for about three seconds, and recheck whether spark is generated between the spark plug and the grounded portion.

**Spark should be generated.**

Is the inspection result normal?

YES >> INSPECTION END

NO >> Replace spark plug(s) with standard type one(s). For spark plug type, refer to [EM-25. "Removal and Installation"](#).

### 10.CHECK FUEL INJECTOR

1. Turn ignition switch OFF.
2. Remove fuel injector assembly.  
Refer to [EM-39. "Removal and Installation"](#).  
Keep fuel hose and all fuel injectors connected to fuel tube.
3. Disconnect all ignition coil harness connectors.
4. Reconnect all fuel injector harness connectors disconnected.
5. Turn ignition switch ON.
6. Check that fuel does not drip from fuel injector.

Does fuel drip from fuel injector?

YES >> Replace the fuel injector(s) from which fuel is dripping.

NO >> GO TO 11.

### 11.CHECK INTERMITTENT INCIDENT

Refer to [GI-44. "Intermittent Incident"](#).

Is the inspection result normal?

YES >> Replace three way catalyst assembly. Refer to [EX-5. "VQ37VHR : Exploded View"](#).

NO >> Repair or replace harness or connector.



# P0444, P0445 EVAP CANISTER PURGE VOLUME CONTROL SOLENOID VALVE

< DTC/CIRCUIT DIAGNOSIS >

[VQ37VHR FOR MEXICO]

## P0444, P0445 EVAP CANISTER PURGE VOLUME CONTROL SOLENOID VALVE

### DTC Logic

INFOID:000000007729894

### DTC DETECTION LOGIC

| DTC No. | Trouble diagnosis name  | DTC detecting condition   | Possible cause  |
|---------|---|---|---|
| P0444   | EVAP canister purge volume control solenoid valve circuit open    | An excessively low voltage signal is sent to ECM through the valve  | <ul style="list-style-type: none"> <li>Harness or connectors (The solenoid valve circuit is open or shorted.)</li> <li>EVAP canister purge volume control solenoid valve</li> </ul> |
| P0445   | EVAP canister purge volume control solenoid valve circuit shorted | An excessively high voltage signal is sent to ECM through the valve | <ul style="list-style-type: none"> <li>Harness or connectors (The solenoid valve circuit is shorted.)</li> <li>EVAP canister purge volume control solenoid valve</li> </ul>         |

### DTC CONFIRMATION PROCEDURE

#### 1.CONDITIONING

If DTC Confirmation Procedure has been previously conducted, always perform the following procedure before conducting the next test.

1. Turn ignition switch OFF and wait at least 10 seconds.
2. Turn ignition switch ON.
3. Turn ignition switch OFF and wait at least 10 seconds.

#### TESTING CONDITION:

Before performing the following procedure, confirm battery voltage is more than 11 V at idle.

>> GO TO 2.

#### 2.PERFORM DTC CONFIRMATION PROCEDURE

1. Start engine and let it idle for at least 13 seconds.
2. Check 1st trip DTC.

Is 1st trip DTC detected?

- YES >> Go to [EC-793. "Diagnosis Procedure"](#).  
 NO >> INSPECTION END

### Diagnosis Procedure

INFOID:000000007729895

#### 1.CHECK EVAP CANISTER PURGE VOLUME CONTROL SOLENOID VALVE POWER SUPPLY CIRCUIT

1. Turn ignition switch OFF.
2. Disconnect EVAP canister purge volume control solenoid valve harness connector.
3. Turn ignition switch ON.
4. Check the voltage between EVAP canister purge volume control solenoid valve harness connector and ground.

| EVAP canister purge volume control solenoid valve |          | Ground | Voltage         |
|---|----------|--------|-----------------|
| Connector   | Terminal |        |                 |
| F7  | 1        | Ground | Battery voltage |

Is the inspection result normal?

- YES >> GO TO 3.  
 NO >> GO TO 2.

#### 2.DETECT MALFUNCTIONING PART

Check the following.

- Harness connectors E106, M6
- Harness connectors M116, F103
- Harness for open or short between EVAP canister purge volume control solenoid valve and IPDM E/R

# P0444, P0445 EVAP CANISTER PURGE VOLUME CONTROL SOLENOID VALVE

< DTC/CIRCUIT DIAGNOSIS >

[VQ37VHR FOR MEXICO]

- Harness for open or short between EVAP canister purge volume control solenoid valve and ECM

>> Repair open circuit, short to ground or short to power in harness or connectors.

## 3. CHECK EVAP CANISTER PURGE VOLUME CONTROL SOLENOID VALVE OUTPUT SIGNAL CIRCUIT FOR OPEN AND SHORT

1. Turn ignition switch OFF.
2. Disconnect ECM harness connector.
3. Check the continuity between EVAP canister purge volume control solenoid valve harness connector and ECM harness connector.

| EVAP canister purge volume control solenoid valve |          | ECM       |          | Continuity |
|---|----------|-----------|----------|------------|
| Connector   | Terminal | Connector | Terminal |            |
| F7  | 2        | F101      | 21       | Existed    |

4. Also check harness for short to ground and short to power.

Is the inspection result normal?

YES-1 >> With CONSULT: GO TO 4.

YES-2 >> Without CONSULT: GO TO 5.

NO >> Repair open circuit, short to ground or short to power in harness or connectors.

## 4. CHECK EVAP CANISTER PURGE VOLUME CONTROL SOLENOID VALVE OPERATION

**Ⓟ With CONSULT**

1. Reconnect all harness connectors disconnected.
2. Start engine.
3. Perform "PURG VOL CONT/V" in "ACTIVE TEST" mode with CONSULT. Check that engine speed varies according to the valve opening.

Does engine speed vary according to the valve opening?

YES >> GO TO 6.

NO >> GO TO 5.

## 5. CHECK EVAP CANISTER PURGE VOLUME CONTROL SOLENOID VALVE

Refer to [EC-794, "Component Inspection"](#).

Is the inspection result normal?

YES >> GO TO 6.

NO >> Replace EVAP canister purge volume control solenoid valve. Refer to [EM-31, "Exploded View"](#).

## 6. CHECK INTERMITTENT INCIDENT

Refer to [GI-44, "Intermittent Incident"](#).

>> INSPECTION END

## Component Inspection

INFOID:000000007729896

## 1. CHECK EVAP CANISTER PURGE VOLUME CONTROL SOLENOID VALVE

**Ⓟ With CONSULT**

1. Turn ignition switch OFF.
2. Reconnect all harness connectors disconnected.
3. Disconnect EVAP purge hoses connected to EVAP canister purge volume control solenoid valve.
4. Turn ignition switch ON.
5. Select "PURG VOL CONT/V" in "ACTIVE TEST" mode with CONSULT.

# P0444, P0445 EVAP CANISTER PURGE VOLUME CONTROL SOLENOID VALVE

[VQ37VHR FOR MEXICO]

## < DTC/CIRCUIT DIAGNOSIS >

- Touch "Qd" and "Qu" on CONSULT screen to adjust "PURG VOL C/V" opening and check air passage continuity of EVAP canister purge volume control solenoid valve under the following conditions.

| Condition<br>(PURG VOL C/V value) | Air passage continuity<br>between (A) and (B) |
|-----------------------------------|---|
| 100%                              | Existed                                       |
| 0%                                | Not existed                                   |

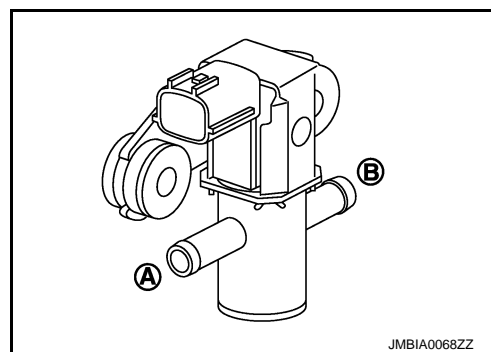

### Without CONSULT

- Turn ignition switch OFF.
- Disconnect EVAP canister purge volume control solenoid valve harness connector.
- Disconnect EVAP purge hoses connected to EVAP canister purge volume control solenoid valve.
- Check air passage continuity of EVAP canister purge volume control solenoid valve under the following conditions.

| Condition   | Air passage continuity<br>between (A) and (B) |
|---|---|
| 12 V direct current supply between<br>terminals 1 and 2 | Existed                                       |
| No supply   | Not existed                                   |

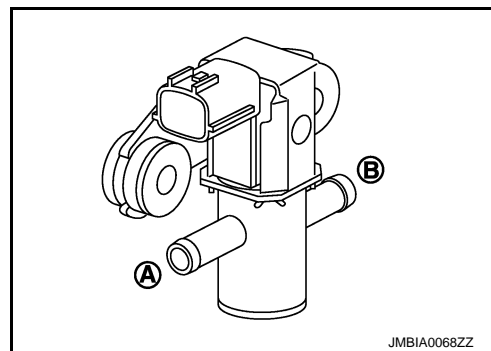

### Is the inspection result normal?

YES >> INSPECTION END

NO >> Replace EVAP canister purge volume control solenoid valve. Refer to [EM-31, "Exploded View"](#).

A  
EC  
C  
D  
E  
F  
G  
H  
I  
J  
K  
L  
M  
N  
O  
P

# P0447 EVAP CANISTER VENT CONTROL VALVE

< DTC/CIRCUIT DIAGNOSIS >

[VQ37VHR FOR MEXICO]

## P0447 EVAP CANISTER VENT CONTROL VALVE

### DTC Logic

INFOID:000000007792872

### DTC DETECTION LOGIC

| DTC No. | Trouble diagnosis name                        | DTC detecting condition   | Possible cause   |
|---------|---|---|--|
| P0447   | EVAP canister vent control valve circuit open | An improper voltage signal is sent to ECM through EVAP canister vent control valve. | <ul style="list-style-type: none"><li>• Harness or connectors (The valve circuit is open or shorted.)</li><li>• EVAP canister vent control valve</li></ul> |

### DTC CONFIRMATION PROCEDURE

#### 1. PRECONDITIONING

If DTC Confirmation Procedure has been previously conducted, always perform the following procedure before conducting the next test.

1. Turn ignition switch OFF and wait at least 10 seconds.
2. Turn ignition switch ON.
3. Turn ignition switch OFF and wait at least 10 seconds.

#### TESTING CONDITION:

**Before performing the following procedure, confirm battery voltage is more than 11 V at idle.**

>> GO TO 2.

#### 2. PERFORM DTC CONFIRMATION PROCEDURE

1. Start engine and wait at least 8 seconds.
2. Check 1st trip DTC.

Is 1st trip DTC detected?

- YES >> Go to [EC-796, "Diagnosis Procedure"](#).  
NO >> INSPECTION END

### Diagnosis Procedure

INFOID:000000007792873

#### 1. INSPECTION START

Do you have CONSULT?

Do you have CONSULT?

- YES >> GO TO 2.  
NO >> GO TO 3.

#### 2. CHECK EVAP CANISTER VENT CONTROL VALVE CIRCUIT

##### With CONSULT

1. Turn ignition switch OFF and then ON.
2. Select "VENT CONTROL/V" in "ACTIVE TEST" mode with CONSULT.
3. Touch "ON/OFF" on CONSULT screen.
4. Check for operating sound of the valve.

**Clicking sound should be heard.**

Is the inspection result normal?

- YES >> GO TO 7.  
NO >> GO TO 3.

#### 3. CHECK EVAP CANISTER VENT CONTROL VALVE POWER SUPPLY CIRCUIT

1. Turn ignition switch OFF.
2. Disconnect EVAP canister vent control valve harness connector.
3. Turn ignition switch ON.
4. Check the voltage between EVAP canister vent control valve harness connector and ground.

# P0447 EVAP CANISTER VENT CONTROL VALVE

< DTC/CIRCUIT DIAGNOSIS >

[VQ37VHR FOR MEXICO]

| EVAP canister vent control valve |          | Ground | Voltage         |
|----------------------------------|----------|--------|-----------------|
| Connector                        | Terminal |        |                 |
| B74                              | 1        | Ground | Battery voltage |

Is the inspection result normal?

- YES >> GO TO 5.
- NO >> GO TO 4.

## 4. DETECT MALFUNCTIONING PART

Check the following.

- Harness connectors B8, E115
- Harness connectors B71, B72
- Harness for open or short between EVAP canister vent control valve and IPDM E/R

>> Repair open circuit, short to ground or short to power in harness or connectors.

## 5. CHECK EVAP CANISTER VENT CONTROL VALVE OUTPUT SIGNAL CIRCUIT FOR OPEN AND SHORT

1. Turn ignition switch OFF.
2. Disconnect ECM harness connector.
3. Check the continuity between EVAP canister vent control valve harness connector and ECM harness connector.

| EVAP canister vent control valve |          | ECM       |          | Continuity |
|----------------------------------|----------|-----------|----------|------------|
| Connector                        | Terminal | Connector | Terminal |            |
| B74                              | 2        | M107      | 121      | Existed    |

4. Also check harness for short to ground and short to power.

Is the inspection result normal?

- YES >> GO TO 7.
- NO >> GO TO 6.

## 6. DETECT MALFUNCTIONING PART

Check the following.

- Harness connectors B1, M7
- Harness connectors B71, B72
- Harness for open or short between EVAP canister vent control valve and ECM

>> Repair open circuit, short to ground or short to power in harness or connectors.

## 7. CHECK RUBBER TUBE FOR CLOGGING

1. Disconnect rubber tube connected to EVAP canister vent control valve.
2. Check the rubber tube for clogging.

Is the inspection result normal?

- YES >> GO TO 8.
- NO >> Clean the rubber tube using an air blower.

## 8. CHECK EVAP CANISTER VENT CONTROL VALVE

Refer to [EC-798, "Component Inspection"](#).

Is the inspection result normal?

- YES >> GO TO 9.
- NO >> Replace EVAP canister vent control valve. Refer to [FL-13, "Exploded View"](#).

## 9. CHECK INTERMITTENT INCIDENT

Refer to [GI-44, "Intermittent Incident"](#).

>> INSPECTION END

# P0447 EVAP CANISTER VENT CONTROL VALVE

[VQ37VHR FOR MEXICO]

< DTC/CIRCUIT DIAGNOSIS >

INFOID:000000007792874

## Component Inspection

### 1. CHECK EVAP CANISTER VENT CONTROL VALVE-I

1. Turn ignition switch OFF.
2. Remove EVAP canister vent control valve from EVAP canister. Refer to [FL-13, "Exploded View"](#).
3. Check portion (A) of EVAP canister vent control valve for rust.

Is it rusted?

- YES >> Replace EVAP canister vent control valve. Refer to [FL-13, "Exploded View"](#).
- NO >> GO TO 2.

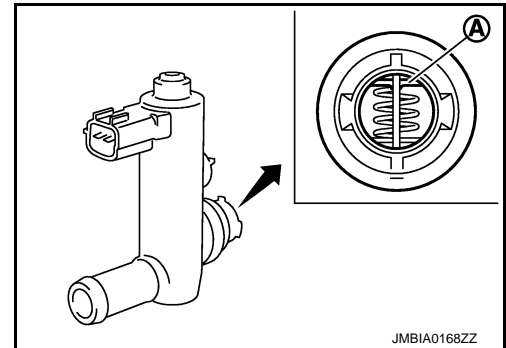

### 2. CHECK EVAP CANISTER VENT CONTROL VALVE-II

#### Ⓟ With CONSULT

1. Reconnect harness connectors disconnected.
2. Turn ignition switch ON.
3. Perform "VENT CONTROL/V" in "ACTIVE TEST" mode.
4. Check air passage continuity and operation delay time.  
**Make sure that new O-ring is installed properly.**

| Condition VENT CONT/V | Air passage continuity between (A) and (B) |
|-----------------------|--|
| ON                    | Not existed                                |
| OFF                   | Existed                                    |

**Operation takes less than 1 second.**

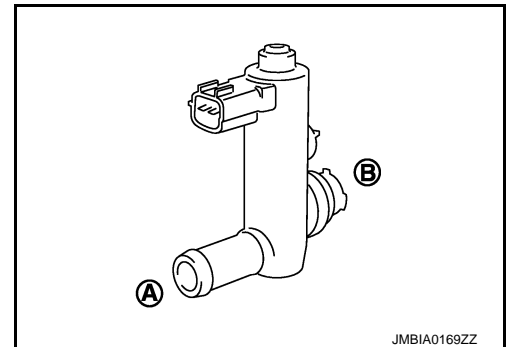

#### ⓧ Without CONSULT

1. Disconnect EVAP canister vent control valve harness connector.
2. Check air passage continuity and operation delay time under the following conditions.  
**Make sure that new O-ring is installed properly.**

| Condition  | Air passage continuity between (A) and (B) |
|--|--|
| 12 V direct current supply between terminals 1 and 2 | Not existed                                |
| OFF  | Existed                                    |

**Operation takes less than 1 second.**

Is the inspection result normal?

- YES >> GO TO 3.
- NO >> Replace EVAP canister vent control valve. Refer to [FL-13, "Exploded View"](#).

### 3. CHECK EVAP CANISTER VENT CONTROL VALVE-III

#### Ⓟ With CONSULT

1. Clean the air passage [portion (A) to (B)] of EVAP canister vent control valve using an air blower.
2. Perform "VENT CONTROL/V" in "ACTIVE TEST" mode.

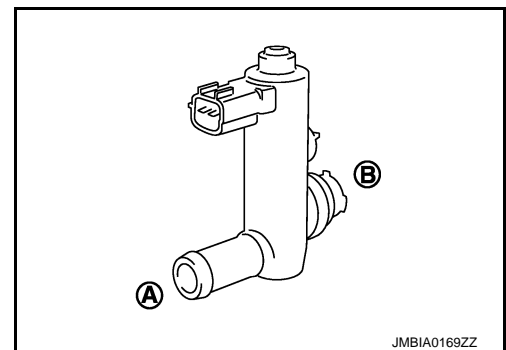

# P0447 EVAP CANISTER VENT CONTROL VALVE

[VQ37VHR FOR MEXICO]

## < DTC/CIRCUIT DIAGNOSIS >

3. Check air passage continuity and operation delay time.  
**Make sure that new O-ring is installed properly.**

| Condition VENT CONT/V | Air passage continuity between (A) and (B) |
|-----------------------|--|
| ON                    | Not existed                                |
| OFF                   | Existed                                    |

**Operation takes less than 1 second.**

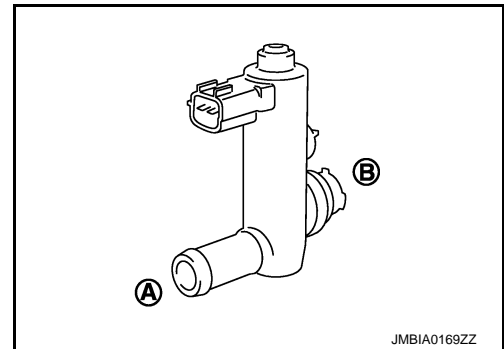

### Without CONSULT

1. Clean the air passage [portion (A) to (B)] of EVAP canister vent control valve using an air blower.
2. Check air passage continuity and operation delay time under the following conditions.

**Make sure that new O-ring is installed properly.**

| Condition  | Air passage continuity between (A) and (B) |
|--|--|
| 12 V direct current supply between terminals 1 and 2 | Not existed                                |
| OFF  | Existed                                    |

**Operation takes less than 1 second.**

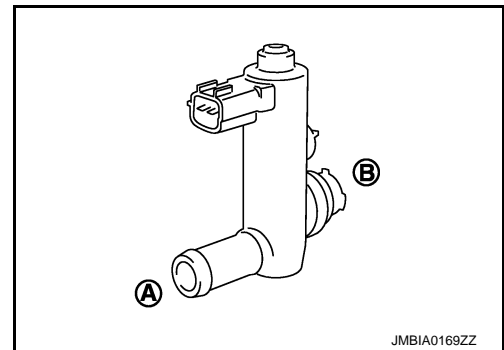

Is the inspection result normal?

YES >> INSPECTION END

NO >> Replace EVAP canister vent control valve. Refer to [FL-13, "Exploded View"](#).

A  
EC  
C  
D  
E  
F  
G  
H  
I  
J  
K  
L  
M  
N  
O  
P

# P0452 EVAP CONTROL SYSTEM PRESSURE SENSOR

< DTC/CIRCUIT DIAGNOSIS >

[VQ37VHR FOR MEXICO]

## P0452 EVAP CONTROL SYSTEM PRESSURE SENSOR

### DTC Logic

INFOID:000000007729906

### DTC DETECTION LOGIC

| DTC No. | Trouble diagnosis name                        | DTC detecting condition                                    | Possible cause   |
|---------|---|--|--|
| P0452   | EVAP control system pressure sensor low input | An excessively low voltage from the sensor is sent to ECM. | <ul style="list-style-type: none"> <li>• Harness or connectors (EVAP control system pressure sensor circuit is open or shorted.) [CKP sensor (POS) circuit is shorted.] (APP sensor 2 circuit is shorted.) [CMP sensor (PHASE) (bank 2) circuit is open or shorted.] (Battery current sensor circuit is open or shorted.) (Refrigerant pressure sensor circuit is shorted.)</li> <li>• EVAP control system pressure sensor</li> <li>• Crankshaft position sensor (POS)</li> <li>• Accelerator pedal position sensor</li> <li>• Camshaft position sensor (PHASE) (bank 2)</li> <li>• Battery current sensor</li> <li>• Refrigerant pressure sensor</li> </ul> |

### DTC CONFIRMATION PROCEDURE

#### 1. PRECONDITIONING

If DTC Confirmation Procedure has been previously conducted, always perform the following procedure before conducting the next test.

1. Turn ignition switch OFF and wait at least 10 seconds.
2. Turn ignition switch ON.
3. Turn ignition switch OFF and wait at least 10 seconds.

#### TESTING CONDITION:

**Always perform test at a temperature of 5°C (41°F) or more.**

>> GO TO 2.

#### 2. PERFORM DTC CONFIRMATION PROCEDURE

##### With CONSULT

1. Start engine and warm it up to normal operating temperature.
2. Turn ignition switch OFF and wait at least 10 seconds.
3. Turn ignition switch ON.
4. Turn ignition switch OFF and wait at least 10 seconds.
5. Turn ignition switch ON.
6. Select "DATA MONITOR" mode with CONSULT.
7. Make sure that "FUEL T/TMP SE" is more than 0°C (32°F).
8. Start engine and wait at least 20 seconds.
9. Check 1st trip DTC.

##### With GST

1. Start engine and warm it up to normal operating temperature.
2. Set voltmeter probes to ECM harness connector terminals as per the following.

| ECM       |  |                     |
|-----------|--|---------------------|
| Connector | +  | -                   |
|           | Terminal                                     | Terminal            |
| M107      | 106<br>(Fuel tank temperature sensor signal) | 128<br>(ECM ground) |

3. Make sure that the voltage is less than 4.2 V.
4. Turn ignition switch OFF and wait at least 10 seconds.
5. Turn ignition switch ON.
6. Turn ignition switch OFF and wait at least 10 seconds.



# P0452 EVAP CONTROL SYSTEM PRESSURE SENSOR

[VQ37VHR FOR MEXICO]

## < DTC/CIRCUIT DIAGNOSIS >

7. Start engine and wait at least 20 seconds.
8. Check 1st trip DTC.

Is 1st trip DTC detected?

- YES >> Go to [EC-801, "Diagnosis Procedure"](#).  
NO >> INSPECTION END

## Diagnosis Procedure

INFOID:000000007729907

### 1. CHECK GROUND CONNECTION

1. Turn ignition switch OFF.
2. Check ground connection M95. Refer to Ground Inspection in [GI-47, "Circuit Inspection"](#).

Is the inspection result normal?

- YES >> GO TO 2.  
NO >> Repair or replace ground connection.

### 2. CHECK CONNECTOR

1. Disconnect EVAP control system pressure sensor harness connector.
2. Check sensor harness connector for water.

**Water should not exist.**

Is the inspection result normal?

- YES >> GO TO 3.  
NO >> Repair or replace harness connector.

### 3. CHECK EVAP CONTROL SYSTEM PRESSURE SENSOR POWER SUPPLY CIRCUIT-I

1. Turn ignition switch ON.
2. Check the voltage between EVAP control system pressure sensor harness connector and ground.

| EVAP control system pressure sensor |          | Ground | Voltage (V) |
|-------------------------------------|----------|--------|-------------|
| Connector                           | Terminal |        |             |
| B73                                 | 3        | Ground | Approx. 5   |

Is the inspection result normal?

- YES >> GO TO 10.  
NO >> GO TO 4.

### 4. CHECK EVAP CONTROL SYSTEM PRESSURE SENSOR POWER SUPPLY CIRCUIT-II

1. Turn ignition switch OFF.
2. Disconnect ECM harness connector.
3. Check the continuity between EVAP control system pressure sensor harness connector and ECM harness connector.

| EVAP control system pressure sensor |          | ECM       |          | Continuity |
|-------------------------------------|----------|-----------|----------|------------|
| Connector                           | Terminal | Connector | Terminal |            |
| B73                                 | 3        | M107      | 107      | Existed    |

Is the inspection result normal?

- YES >> GO TO 6.  
NO >> GO TO 5.

### 5. DETECT MALFUNCTIONING PART

Check the following.

- Harness connectors M7, B1
- Harness connectors B71, B72
- Harness for open between ECM and EVAP control system pressure sensor

>> Repair open circuit.

# P0452 EVAP CONTROL SYSTEM PRESSURE SENSOR

< DTC/CIRCUIT DIAGNOSIS >

[VQ37VHR FOR MEXICO]

## 6. CHECK SENSOR POWER SUPPLY CIRCUIT

Check harness for short to power and short to ground, between the following terminals.

| ECM       |          | Sensor                              |  |                                    |
|-----------|----------|-------------------------------------|--|------------------------------------|
| Connector | Terminal | Name                                | Connector                              | Terminal                           |
| F101      | 46       | CKP sensor (POS)                    | F2                                     | 1                                  |
| F102      | 64       | CMP sensor (PHASE) (bank 2)         | F18                                    | 1                                  |
|           |          | Battery current sensor              | E21                                    |                                    |
| M107      | 103      | APP sensor                          | M153 <sup>*1</sup><br>M9 <sup>*2</sup> | 3 <sup>*1</sup><br>6 <sup>*2</sup> |
|           |          | EVAP control system pressure sensor | B73                                    | 3                                  |
|           | 107      | Refrigerant pressure sensor         | E77                                    | 3                                  |

\*1: With ICC

\*2: Without ICC

Is the inspection result normal?

YES >> GO TO 7.

NO >> Repair short to ground or short to power in harness or connectors.

## 7. CHECK COMPONENTS

Check the following.

- Crankshaft position sensor (POS) (Refer to [EC-781, "Component Inspection"](#).)
- Camshaft position sensor (PHASE) (bank 2) (Refer to [EC-786, "Component Inspection"](#).)
- Battery current sensor (Refer to [EC-870, "Component Inspection"](#).)
- Refrigerant pressure sensor (Refer to [EC-967, "Diagnosis Procedure"](#).)

Is the inspection result normal?

YES >> GO TO 8.

NO >> Replace malfunctioning component.

## 8. CHECK APP SENSOR

Refer to [EC-920, "Component Inspection"](#).

Is the inspection result normal?

YES >> GO TO 15.

NO >> GO TO 9.

## 9. REPLACE ACCELERATOR PEDAL ASSEMBLY

1. Replace accelerator pedal assembly
2. Go to [EC-920, "Special Repair Requirement"](#).

>> INSPECTION END

## 10. CHECK EVAP CONTROL SYSTEM PRESSURE SENSOR GROUND CIRCUIT FOR OPEN AND SHORT

1. Turn ignition switch OFF.
2. Disconnect ECM harness connector.
3. Check the continuity between EVAP control system pressure sensor harness connector and ECM harness connector.

| EVAP control system pressure sensor |          | ECM       |          | Continuity |
|-------------------------------------|----------|-----------|----------|------------|
| Connector                           | Terminal | Connector | Terminal |            |
| B73                                 | 1        | M107      | 112      | Existed    |

4. Also check harness for short to ground and short to power.

Is the inspection result normal?

# P0452 EVAP CONTROL SYSTEM PRESSURE SENSOR

[VQ37VHR FOR MEXICO]

< DTC/CIRCUIT DIAGNOSIS >

- YES >> GO TO 12.
- NO >> GO TO 11.

## 11.DETECT MALFUNCTIONING PART

Check the following.

- Harness connectors B1, M7
- Harness connectors B71, B72
- Harness for open or short between EVAP control system pressure sensor and ECM

>> Repair open circuit, short to ground or short to power in harness or connectors.

## 12.CHECK EVAP CONTROL SYSTEM PRESSURE SENSOR INPUT SIGNAL CIRCUIT FOR OPEN AND SHORT

1. Check the continuity between EVAP control system pressure sensor harness connector and ECM harness connector.

| EVAP control system pressure sensor |          | ECM       |          | Continuity |
|-------------------------------------|----------|-----------|----------|------------|
| Connector                           | Terminal | Connector | Terminal |            |
| B73                                 | 2        | M107      | 102      | Existed    |

2. Also check harness for short to ground and short to power.

Is the inspection result normal?

- YES >> GO TO 14.
- NO >> GO TO 13.

## 13.DETECT MALFUNCTIONING PART

Check the following.

- Harness connectors B1, M7
- Harness connectors B71, B72
- Harness for open or short between EVAP control system pressure sensor and ECM

>> Repair open circuit, short to ground or short to power in harness or connectors.

## 14.CHECK EVAP CONTROL SYSTEM PRESSURE SENSOR

Refer to [EC-803, "Component Inspection"](#).

Is the inspection result normal?

- YES >> GO TO 15.
- NO >> Replace EVAP control system pressure sensor. Refer to [FL-13, "Exploded View"](#).

## 15.CHECK INTERMITTENT INCIDENT

Refer to [GI-44, "Intermittent Incident"](#).

>> INSPECTION END

## Component Inspection

INFOID:000000007729908

### 1.CHECK EVAP CONTROL SYSTEM PRESSURE SENSOR

1. Turn ignition switch OFF.
2. Remove EVAP control system pressure sensor with its harness connector.  
**Always replace O-ring with a new one.**
3. Install a vacuum pump to EVAP control system pressure sensor.
4. Turn ignition switch ON and check output voltage between ECM harness connector terminals under the following conditions.

# P0452 EVAP CONTROL SYSTEM PRESSURE SENSOR

< DTC/CIRCUIT DIAGNOSIS >

[VQ37VHR FOR MEXICO]

| ECM       |          |          | Condition<br>[Applied vacuum kPa (kg/cm <sup>2</sup> , psi)] | Voltage (V)                       |
|-----------|----------|----------|--|-----------------------------------|
| Connector | +        | -        |  |                                   |
|           | Terminal | Terminal |  |                                   |
| M107      | 102      | 112      | Not applied  | 1.8 - 4.8                         |
|           |          |          | -26.7 (-0.272, -3.87)  | 2.1 to 2.5 lower than above value |

**CAUTION:**

- Always calibrate the vacuum pump gauge when using it.
- Never apply below -93.3 kPa (-0.952 kg/cm<sup>2</sup>, -13.53 psi) or pressure over 101.3 kPa (1.033 kg/cm<sup>2</sup>, 14.69 psi).

Is the inspection result normal?

YES >> INSPECTION END

NO >> Replace EVAP control system pressure sensor. Refer to [FL-13, "Exploded View"](#).

# P0453 EVAP CONTROL SYSTEM PRESSURE SENSOR

< DTC/CIRCUIT DIAGNOSIS >

[VQ37VHR FOR MEXICO]

## P0453 EVAP CONTROL SYSTEM PRESSURE SENSOR

### DTC Logic

INFOID:000000007729909

### DTC DETECTION LOGIC

| DTC No. | Trouble diagnosis name                         | DTC detecting condition                                     | Possible cause  |
|---------|--|---|---|
| P0453   | EVAP control system pressure sensor high input | An excessively high voltage from the sensor is sent to ECM. | <ul style="list-style-type: none"> <li>• Harness or connectors (EVAP control system pressure sensor circuit is open or shorted.) [CKP sensor (POS) circuit is shorted.] (APP sensor 2 circuit is shorted.) [CMP sensor (PHASE) (bank 2) circuit is open or shorted.] (Battery current sensor circuit is open or shorted.) (Refrigerant pressure sensor circuit is shorted.)</li> <li>• EVAP control system pressure sensor</li> <li>• Crankshaft position sensor (POS)</li> <li>• Accelerator pedal position sensor</li> <li>• Camshaft position sensor (PHASE) (bank 2)</li> <li>• Battery current sensor</li> <li>• Refrigerant pressure sensor</li> <li>• EVAP canister vent control valve</li> <li>• EVAP canister</li> <li>• Rubber hose from EVAP canister vent control valve to vehicle frame</li> </ul> |

### DTC CONFIRMATION PROCEDURE

#### 1. PRECONDITIONING

If DTC Confirmation Procedure has been previously conducted, always perform the following procedure before conducting the next test.

1. Turn ignition switch OFF and wait at least 10 seconds.
2. Turn ignition switch ON.
3. Turn ignition switch OFF and wait at least 10 seconds.

#### TESTING CONDITION:

**Always perform test at a temperature of 5°C (41°F) or more.**

>> GO TO 2.

#### 2. PERFORM DTC CONFIRMATION PROCEDURE

##### With CONSULT

1. Start engine and warm it up to normal operating temperature.
2. Turn ignition switch OFF and wait at least 10 seconds.
3. Turn ignition switch ON.
4. Turn ignition switch OFF and wait at least 10 seconds.
5. Turn ignition switch ON.
6. Select "DATA MONITOR" mode with CONSULT.
7. Make sure that "FUEL T/TMP SE" is more than 0°C (32°F).
8. Start engine and wait at least 20 seconds.
9. Check 1st trip DTC.

##### With GST

1. Start engine and warm it up to normal operating temperature.
2. Set voltmeter probes to ECM harness connector terminals as per the following.

| ECM       |  |                     |
|-----------|--|---------------------|
| Connector | +  | -                   |
|           | Terminal                                     | Terminal            |
| M107      | 106<br>(Fuel tank temperature sensor signal) | 128<br>(ECM ground) |

3. Make sure that the voltage is less than 4.2 V.

# P0453 EVAP CONTROL SYSTEM PRESSURE SENSOR

[VQ37VHR FOR MEXICO]

## < DTC/CIRCUIT DIAGNOSIS >

4. Turn ignition switch OFF and wait at least 10 seconds.
5. Turn ignition switch ON.
6. Turn ignition switch OFF and wait at least 10 seconds.
7. Start engine and wait at least 20 seconds.
8. Check 1st trip DTC.

### Is 1st trip DTC detected?

- YES >> Go to [EC-806, "Diagnosis Procedure"](#).  
NO >> INSPECTION END

## Diagnosis Procedure

INFOID:000000007729910

### 1.CHECK GROUND CONNECTION

1. Turn ignition switch OFF.
2. Check ground connection M95. Refer to Ground Inspection in [GI-47, "Circuit Inspection"](#).

#### Is the inspection result normal?

- YES >> GO TO 2.  
NO >> Repair or replace ground connection.

### 2.CHECK CONNECTOR

1. Disconnect EVAP control system pressure sensor harness connector.
2. Check sensor harness connector for water.

**Water should not exist.**

#### Is the inspection result normal?

- YES >> GO TO 3.  
NO >> Repair or replace harness connector.

### 3.CHECK EVAP CONTROL SYSTEM PRESSURE SENSOR POWER SUPPLY CIRCUIT

1. Turn ignition switch ON.
2. Check the voltage between EVAP control system pressure sensor harness connector and ground.

| EVAP control system pressure sensor |          | Ground | Voltage (V) |
|-------------------------------------|----------|--------|-------------|
| Connector                           | Terminal |        |             |
| B73                                 | 3        | Ground | Approx. 5   |

#### Is the inspection result normal?

- YES >> GO TO 10.  
NO >> GO TO 4.

### 4.CHECK EVAP CONTROL SYSTEM PRESSURE SENSOR POWER SUPPLY CIRCUIT-II

1. Turn ignition switch OFF.
2. Disconnect ECM harness connector.
3. Check the continuity between EVAP control system pressure sensor harness connector and ECM harness connector.

| EVAP control system pressure sensor |          | ECM       |          | Continuity |
|-------------------------------------|----------|-----------|----------|------------|
| Connector                           | Terminal | Connector | Terminal |            |
| B73                                 | 3        | M107      | 107      | Existed    |

#### Is the inspection result normal?

- YES >> GO TO 6.  
NO >> GO TO 5.

### 5.DETECT MALFUNCTIONING PART

Check the following.

- Harness connectors M7, B1
- Harness connectors B71, B72

# P0453 EVAP CONTROL SYSTEM PRESSURE SENSOR

< DTC/CIRCUIT DIAGNOSIS >

[VQ37VHR FOR MEXICO]

- Harness for open between ECM and EVAP control system pressure sensor

>> Repair open circuit.

## 6. CHECK SENSOR POWER SUPPLY CIRCUIT

Check harness for short to power and short to ground, between the following terminals.

| ECM       |          | Sensor                              |                |            |
|-----------|----------|-------------------------------------|----------------|------------|
| Connector | Terminal | Name                                | Connector      | Terminal   |
| F101      | 46       | CKP sensor (POS)                    | F2             | 1          |
| F102      | 64       | CMP sensor (PHASE) (bank 2)         | F18            | 1          |
|           |          | Battery current sensor              | E21            |            |
| M107      | 103      | APP sensor                          | M153*1<br>M9*2 | 3*1<br>6*2 |
|           |          | EVAP control system pressure sensor | B73            | 3          |
|           | 107      | Refrigerant pressure sensor         | E77            | 3          |

\*1: With ICC

\*2: Without ICC

Is the inspection result normal?

YES >> GO TO 7.

NO >> Repair short to ground or short to power in harness or connectors.

## 7. CHECK COMPONENTS

Check the following.

- Crankshaft position sensor (POS) (Refer to [EC-781, "Component Inspection"](#).)
- Camshaft position sensor (PHASE) (bank 2) (Refer to [EC-786, "Component Inspection"](#).)
- Battery current sensor (Refer to [EC-870, "Component Inspection"](#).)
- Refrigerant pressure sensor (Refer to [EC-967, "Diagnosis Procedure"](#).)

Is the inspection result normal?

YES >> GO TO 8.

NO >> Replace malfunctioning component.

## 8. CHECK APP SENSOR

Refer to [EC-920, "Component Inspection"](#).

Is the inspection result normal?

YES >> GO TO 20.

NO >> GO TO 9.

## 9. REPLACE ACCELERATOR PEDAL ASSEMBLY

1. Replace accelerator pedal assembly
2. Go to [EC-920, "Special Repair Requirement"](#).

>> INSPECTION END

## 10. CHECK EVAP CONTROL SYSTEM PRESSURE SENSOR GROUND CIRCUIT FOR OPEN AND SHORT

1. Turn ignition switch OFF.
2. Disconnect ECM harness connector.
3. Check the continuity between EVAP control system pressure sensor harness connector and ECM harness connector.

| EVAP control system pressure sensor |          | ECM       |          | Continuity |
|-------------------------------------|----------|-----------|----------|------------|
| Connector                           | Terminal | Connector | Terminal |            |
| B73                                 | 1        | M107      | 112      | Existed    |

# P0453 EVAP CONTROL SYSTEM PRESSURE SENSOR

[VQ37VHR FOR MEXICO]

< DTC/CIRCUIT DIAGNOSIS >

4. Also check harness for short to ground and short to power.

Is the inspection result normal?

- YES >> GO TO 12.
- NO >> GO TO 11.

## 11.DETECT MALFUNCTIONING PART

Check the following.

- Harness connectors B1, M7
- Harness connectors B71, B72
- Harness for open or short between EVAP control system pressure sensor and ECM

>> Repair open circuit, short to ground or short to power in harness or connectors.

## 12.CHECK EVAP CONTROL SYSTEM PRESSURE SENSOR INPUT SIGNAL CIRCUIT FOR OPEN AND SHORT

1. Check the continuity between EVAP control system pressure sensor harness connector and ECM harness connector.

| EVAP control system pressure sensor |          | ECM       |          | Continuity |
|-------------------------------------|----------|-----------|----------|------------|
| Connector                           | Terminal | Connector | Terminal |            |
| B73                                 | 2        | M107      | 102      | Existed    |

2. Also check harness for short to ground and short to power.

Is the inspection result normal?

- YES >> GO TO 14.
- NO >> GO TO 13.

## 13.DETECT MALFUNCTIONING PART

Check the following.

- Harness connectors B1, M7
- Harness connectors B71, B72
- Harness for open or short between EVAP control system pressure sensor and ECM

>> Repair open circuit, short to ground or short to power in harness or connectors.

## 14.CHECK RUBBER TUBE

1. Disconnect rubber tube connected to EVAP canister vent control valve.

2. Check the rubber tube for clogging.

Is the inspection result normal?

- YES >> GO TO 15.
- NO >> Clean the rubber tube using an air blower, repair or replace rubber tube.

## 15.CHECK EVAP CANISTER VENT CONTROL VALVE

Refer to [EC-798, "Component Inspection"](#).

Is the inspection result normal?

- YES >> GO TO 16.
- NO >> Replace EVAP canister vent control valve. Refer to [FL-13, "Exploded View"](#).

## 16.CHECK EVAP CONTROL SYSTEM PRESSURE SENSOR

Refer to [EC-809, "Component Inspection"](#).

Is the inspection result normal?

- YES >> GO TO 17.
- NO >> Replace EVAP control system pressure sensor. Refer to [FL-13, "Exploded View"](#).

## 17.CHECK IF EVAP CANISTER IS SATURATED WITH WATER

1. Remove EVAP canister with EVAP canister vent control valve and EVAP control system pressure sensor attached.



# P0453 EVAP CONTROL SYSTEM PRESSURE SENSOR

[VQ37VHR FOR MEXICO]

## < DTC/CIRCUIT DIAGNOSIS >

2. Check if water will drain from the EVAP canister (1).

2 : EVAP canister vent control valve

Does water drain from EVAP canister?

- YES >> GO TO 18.
- NO >> GO TO 20.

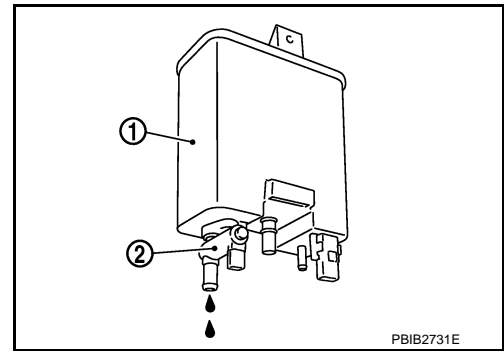

PBIB2731E

## 18. CHECK EVAP CANISTER

Weigh the EVAP canister with the EVAP canister vent control valve and EVAP control system pressure sensor attached.

**The weight should be less than 2.1 kg (4.6 lb).**

Is the inspection result normal?

- YES >> GO TO 20.
- NO >> GO TO 19.

## 19. DETECT MALFUNCTIONING PART

Check the following.

- EVAP canister for damage
- EVAP hose between EVAP canister and vehicle frame for clogging or poor connection

>> Repair hose or replace EVAP canister.

## 20. CHECK INTERMITTENT INCIDENT

Refer to [GI-44, "Intermittent Incident"](#).

>> INSPECTION END

## Component Inspection

INFOID:000000007729911

## 1. CHECK EVAP CONTROL SYSTEM PRESSURE SENSOR

1. Turn ignition switch OFF.
2. Remove EVAP control system pressure sensor with its harness connector.  
**Always replace O-ring with a new one.**
3. Install a vacuum pump to EVAP control system pressure sensor.
4. Turn ignition switch ON and check output voltage between ECM harness connector terminals under the following conditions.

| Connector | ECM      |          | Condition<br>[Applied vacuum kPa (kg/cm <sup>2</sup> , psi)] | Voltage (V)                       |
|-----------|----------|----------|--|-----------------------------------|
|           | +        | -        |  |                                   |
|           | Terminal | Terminal |  |                                   |
| M107      | 102      | 112      | Not applied  | 1.8 - 4.8                         |
|           |          |          | -26.7 (-0.272, -3.87)  | 2.1 to 2.5 lower than above value |

### CAUTION:

- **Always calibrate the vacuum pump gauge when using it.**
- **Do not apply below -93.3 kPa (-0.952 kg/cm<sup>2</sup>, -13.53 psi) or pressure over 101.3 kPa (1.033 kg/cm<sup>2</sup>, 14.69 psi).**

Is the inspection result normal?

- YES >> INSPECTION END
- NO >> Replace EVAP control system pressure sensor. Refer to [FL-13, "Exploded View"](#).

P0500 VSS

Description

INFOID:000000007729922

The vehicle speed signal is sent to the “combination meter” from the “ABS actuator and electric unit (control unit)” via the CAN communication line. The “combination meter” then sends a signal to the ECM via the CAN communication line.

DTC Logic

INFOID:000000007729923

DTC DETECTION LOGIC

NOTE:

- If DTC P0500 is displayed with DTC UXXXX, first perform the trouble diagnosis for DTC UXXXX.
- If DTC P0500 is displayed with DTC P0607, first perform the trouble diagnosis for DTC P0607. Refer to [EC-821, "DTC Logic"](#).

| DTC No. | Trouble diagnosis name | DTC detecting condition  | Possible cause   |
|---------|------------------------|--|--|
| P0500   | Vehicle speed sensor   | The vehicle speed signal sent to ECM is almost 0 km/h (0 MPH) even when vehicle is being driven. | <ul style="list-style-type: none"> <li>• Harness or connectors (The CAN communication line is open or shorted)</li> <li>• Harness or connectors (The vehicle speed signal circuit is open or shorted)</li> <li>• Wheel sensor</li> <li>• Combination meter</li> <li>• ABS actuator and electric unit (control unit)</li> </ul> |

DTC CONFIRMATION PROCEDURE

1.INSPECTION START

Do you have CONSULT?

Do you have CONSULT?

- YES >> GO TO 2.
- NO >> GO TO 5.

2.PRECONDITIONING

If DTC Confirmation Procedure has been previously conducted, always perform the following procedure before conducting the next test.

1. Turn ignition switch OFF and wait at least 10 seconds.
2. Turn ignition switch ON.
3. Turn ignition switch OFF and wait at least 10 seconds.

>> GO TO 3.

3.CHECK VEHICLE SPEED SIGNAL

NOTE:

**This procedure may be conducted with the drive wheels lifted in the shop or by driving the vehicle. If a road test is expected to be easier, it is unnecessary to lift the vehicle.**

 With CONSULT

1. Start engine (VDC switch OFF).
2. Read “VHCL SPEED SE” in “DATA MONITOR” mode with CONSULT. The vehicle speed on CONSULT should exceed 10 km/h (6 MPH) when rotating wheels with suitable gear position.

Is the inspection result normal?

- YES >> GO TO 4.
- NO >> Go to [EC-811, "Diagnosis Procedure"](#).

4.PERFORM DTC CONFIRMATION PROCEDURE

1. Select “DATA MONITOR” mode with CONSULT.
2. Warm engine up to normal operating temperature.
3. Maintain the following conditions for at least 50 consecutive seconds.

**CAUTION:**

**Always drive vehicle at a safe speed.**

|                |                        |
|----------------|------------------------|
| ENG SPEED      | 1,500 - 6,000 rpm      |
| COOLAN TEMP/S  | More than 70°C (158°F) |
| B/FUEL SCHDL   | 6.5 - 31.8 msec        |
| Selector lever | Except P or N position |
| PW/ST SIGNAL   | OFF                    |

4. Check 1st trip DTC.

Is 1st trip DTC detected?

YES >> Go to [EC-811, "Diagnosis Procedure"](#).

NO >> INSPECTION END

## 5.PERFORM COMPONENT FUNCTION CHECK

Perform component function check. Refer to [EC-811, "Component Function Check"](#).

Use component function check to check the overall function of the vehicle speed signal circuit. During this check, a 1st trip DTC might not be confirmed.

Is the inspection result normal?

YES >> INSPECTION END

NO >> Go to [EC-811, "Diagnosis Procedure"](#).

## Component Function Check

INFOID:000000007729924

### 1.PERFORM COMPONENT FUNCTION CHECK

#### With GST

1. Lift up drive wheels.

2. Start engine.

3. Read vehicle speed signal in Service \$01 with GST.

The vehicle speed signal on GST should be able to exceed 10 km/h (6 MPH) when rotating wheels with suitable gear position.

Is the inspection result normal?

YES >> INSPECTION END

NO >> Go to [EC-811, "Diagnosis Procedure"](#).

## Diagnosis Procedure

INFOID:000000007729925

### 1.CHECK DTC WITH “ABS ACTUATOR AND ELECTRIC UNIT (CONTROL UNIT)”

Refer to [BRC-40, "CONSULT Function"](#).

Is the inspection result normal?

YES >> GO TO 2.

NO >> Repair or replace.

### 2.CHECK DTC WITH “COMBINATION METER”

Refer to [MWI-31, "CONSULT Function"](#).

>> INSPECTION END

# P0524 ENGINE OIL PRESSURE

< DTC/CIRCUIT DIAGNOSIS >

[VQ37VHR FOR MEXICO]

## P0524 ENGINE OIL PRESSURE

### DTC Logic

INFOID:000000007729935

### DTC DETECTION LOGIC

#### NOTE:

If DTC P0524 is displayed with DTC P0075 or P0081, first perform the trouble diagnosis for DTC P0075, P0081. Refer to [EC-703, "DTC Logic"](#)

| DTC No. | Trouble diagnosis name      | Detecting condition  | Possible cause  |
|---------|-----------------------------|--|---|
| P0524   | Engine oil pressure too low | Engine oil pressure is low because there is a gap between angle of target and phase-control angle. | <ul style="list-style-type: none"><li>• Engine oil pressure or level too low</li><li>• Crankshaft position sensor (POS)</li><li>• Camshaft position sensor (PHASE)</li><li>• Intake valve control solenoid valve</li><li>• Accumulation of debris to the signal pick-up portion of the camshaft</li><li>• Timing chain installation</li><li>• Foreign matter caught in the oil groove for intake valve timing control</li></ul> |

### DTC CONFIRMATION PROCEDURE

#### 1. PRECONDITIONING-I

If DTC Confirmation Procedure has been previously conducted, always perform the following procedure before conducting the next test.

1. Turn ignition switch OFF and wait at least 10 seconds.
2. Turn ignition switch ON.
3. Turn ignition switch OFF and wait at least 10 seconds.

#### TESTING CONDITION:

Before performing the following procedure, confirm that battery voltage is between 10 V and 16 V at idle.

>> GO TO 2.

#### 2. PRECONDITIONING-II

Check oil level and oil pressure. Refer to [LU-7, "Inspection"](#).

Is the inspection result normal?

- YES >> GO TO 3.  
NO >> Go to [LU-7, "Inspection"](#).

#### 3. PERFORM DTC CONFIRMATION PROCEDURE

1. Select "DATA MONITOR" mode with CONSULT.
2. Maintain the following conditions for at least 20 consecutive seconds.

|                  |   |
|------------------|---|
| ENG SPEED        | More than 1,700 rpm   |
| COOLAN TEMP/S    | More than 70°C (158°F)  |
| Selector lever   | 1st or 2nd position   |
| Driving location | Driving vehicle uphill<br>(Increased engine load will help maintain the driving conditions required for this test.) |

#### CAUTION:

Always drive at a safe speed.

3. Check 1st trip DTC.

Is 1st trip DTC detected?

- YES >> Go to [EC-813, "Diagnosis Procedure"](#)  
NO >> INSPECTION END

### Diagnosis Procedure

#### 1. CHECK OIL PRESSURE WARNING LAMP

1. Start engine.
2. Check oil pressure warning lamp and confirm it is not illuminated.

Is oil pressure warning lamp illuminated?

- YES >> Go to [LU-7, "Inspection"](#).  
NO >> GO TO 2.

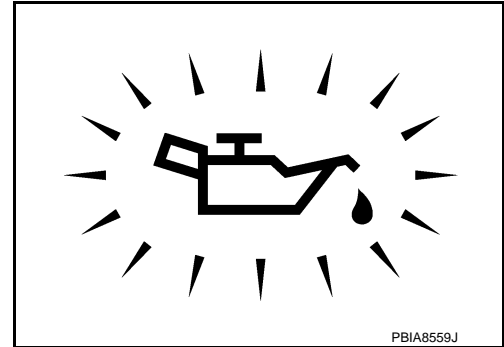

#### 2. CHECK INTAKE VALVE TIMING CONTROL SOLENOID VALVE

Refer to [EC-695, "Component Inspection"](#).

Is the inspection result normal?

- YES >> GO TO 3.  
NO >> Replace malfunctioning intake valve timing control solenoid valve. Refer to [EM-52, "Exploded View"](#).

#### 3. CHECK CRANKSHAFT POSITION SENSOR (POS)

Refer to [EC-781, "Component Inspection"](#).

Is the inspection result normal?

- YES >> GO TO 4.  
NO >> Replace crankshaft position sensor (POS). Refer to [EM-123, "Exploded View"](#).

#### 4. CHECK CAMSHAFT POSITION SENSOR (PHASE)

Refer to [EC-786, "Component Inspection"](#).

Is the inspection result normal?

- YES >> GO TO 5.  
NO >> Replace malfunctioning camshaft position sensor (PHASE). Refer to [EM-52, "Exploded View"](#).

#### 5. CHECK CAMSHAFT (INTAKE)

Check the following.

- Accumulation of debris to the signal plate of camshaft front end
- Chipping signal plate of camshaft front end

Is the inspection result normal?

- YES >> GO TO 6.  
NO >> Remove debris and clean the signal plate of camshaft front end or replace camshaft.

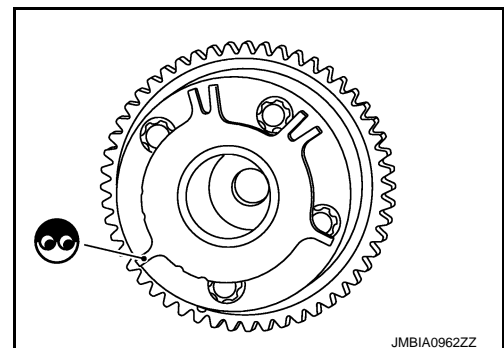

#### 6. CHECK TIMING CHAIN INSTALLATION

Check service records for any recent repairs that may cause timing chain misaligned.

Are there any service records that may cause timing chain misaligned?

- YES >> Check timing chain installation. Refer to [EM-53, "Removal and Installation"](#).  
NO >> GO TO 7.

#### 7. CHECK LUBRICATION CIRCUIT

Perform "Inspection of Camshaft Sprocket (INT) Oil Groove". Refer to [EM-106, "Inspection"](#).

# P0524 ENGINE OIL PRESSURE

[VQ37VHR FOR MEXICO]

< DTC/CIRCUIT DIAGNOSIS >

Is the inspection result normal?

- YES >> GO TO 8.
- NO >> Clean lubrication line.

## 8.CHECK INTERMITTENT INCIDENT

Refer to [GI-44, "Intermittent Incident"](#).

>> INSPECTION END

## Component Inspection

INFOID:000000007729937

### 1.CHECK INTAKE VALVE TIMING CONTROL SOLENOID VALVE-I

1. Turn ignition switch OFF.
2. Disconnect intake valve timing control solenoid valve harness connector.
3. Check resistance between intake valve timing control solenoid valve terminals as per the following.

| Terminals         | Resistance ( $\Omega$ )                   |
|-------------------|---|
| 1 and 2           | 7.0 - 7.7 [at 20°C (68°F)]                |
| 1 or 2 and ground | $\infty$<br>(Continuity should not exist) |

Is the inspection result normal?

- YES >> GO TO 2.
- NO >> Replace malfunctioning intake valve timing control solenoid valve. Refer to [EM-52, "Exploded View"](#).

### 2.CHECK INTAKE VALVE TIMING CONTROL SOLENOID VALVE-II

1. Remove intake valve timing control solenoid valve.
2. Provide 12 V DC between intake valve timing control solenoid valve terminals 1 and 2, and then interrupt it. Make sure that the plunger moves as shown in the figure.

**CAUTION:**

**Never apply 12 V DC continuously for 5 seconds or more. Doing so may result in damage to the coil in intake valve timing control solenoid valve.**

**NOTE:**

**Always replace O-ring when intake valve timing control solenoid valve is removed.**

Is the inspection result normal?

- YES >> INSPECTION END
- NO >> Replace malfunctioning intake valve timing control solenoid valve. Refer to [EM-52, "Exploded View"](#).

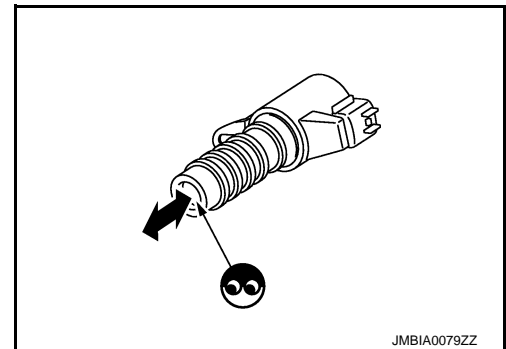

# P0550 PSP SENSOR

< DTC/CIRCUIT DIAGNOSIS >

[VQ37VHR FOR MEXICO]

## P0550 PSP SENSOR

### DTC Logic

INFOID:000000007729938

### DTC DETECTION LOGIC

#### NOTE:

If DTC P0550 is displayed with DTC P0643, first perform the trouble diagnosis for DTC P0643. Refer to [EC-822, "DTC Logic"](#).

| DTC No. | Trouble diagnosis name                 | DTC detecting condition  | Possible cause   |
|---------|--|--|--|
| P0550   | Power steering pressure sensor circuit | An excessively low or high voltage from the sensor is sent to ECM. | <ul style="list-style-type: none"><li>• Harness or connectors (The sensor circuit is open or shorted)</li><li>• Power steering pressure sensor</li></ul> |

### DTC CONFIRMATION PROCEDURE

#### 1. PRECONDITIONING

If DTC Confirmation Procedure has been previously conducted, always perform the following procedure before conducting the next test.

1. Turn ignition switch OFF and wait at least 10 seconds.
2. Turn ignition switch ON.
3. Turn ignition switch OFF and wait at least 10 seconds.

>> GO TO 2.

#### 2. PERFORM DTC CONFIRMATION PROCEDURE

1. Start engine and let it idle for at least 5 seconds.
2. Check 1st trip DTC.

Is 1st trip DTC detected?

- YES >> Go to [EC-815, "Diagnosis Procedure"](#).  
NO >> INSPECTION END

### Diagnosis Procedure

INFOID:000000007729939

#### 1. CHECK GROUND CONNECTION

1. Turn ignition switch OFF.
2. Check ground connection M95. Refer to Ground Inspection in [GI-47, "Circuit Inspection"](#).

Is the inspection result normal?

- YES >> GO TO 2.  
NO >> Repair or replace ground connection.

#### 2. CHECK PSP SENSOR POWER SUPPLY CIRCUIT

1. Disconnect power steering pressure (PSP) sensor harness connector.
2. Turn ignition switch ON.
3. Check the voltage between PSP sensor harness connector and ground.

| PSP sensor |          | Ground | Voltage (V) |
|------------|----------|--------|-------------|
| Connector  | Terminal |        |             |
| F35        | 3        | Ground | Approx. 5   |

Is the inspection result normal?

- YES >> GO TO 3.  
NO >> Repair open circuit, short to ground or short to power in harness or connectors.

#### 3. CHECK PSP SENSOR GROUND CIRCUIT FOR OPEN AND SHORT

1. Turn ignition switch OFF.
2. Disconnect ECM harness connector.

# P0550 PSP SENSOR

[VQ37VHR FOR MEXICO]

## < DTC/CIRCUIT DIAGNOSIS >

3. Check the continuity between PSP sensor harness connector and ECM harness connector.

| PSP sensor |          | ECM       |          | Continuity |
|------------|----------|-----------|----------|------------|
| Connector  | Terminal | Connector | Terminal |            |
| F35        | 1        | F102      | 96       | Existed    |

4. Also check harness for short to ground and short to power.

Is the inspection result normal?

YES >> GO TO 4.

NO >> Repair open circuit, short to ground short to power in harness or connectors.

## 4.CHECK PSP SENSOR INPUT SIGNAL CIRCUIT FOR OPEN AND SHORT

1. Check the continuity between PSP sensor harness connector and ECM harness connector.

| PSP sensor |          | ECM       |          | Continuity |
|------------|----------|-----------|----------|------------|
| Connector  | Terminal | Connector | Terminal |            |
| F35        | 2        | F102      | 87       | Existed    |

2. Also check harness for short to ground and short to power.

Is the inspection result normal?

YES >> GO TO 5.

NO >> Repair open circuit, short to ground or short to power in harness or connectors.

## 5.CHECK PSP SENSOR

Refer to [EC-816. "Component Inspection"](#).

Is the inspection result normal?

YES >> GO TO 6.

NO >> Replace PSP sensor. Refer to [ST-76. "2WD : Exploded View"](#).

## 6.CHECK INTERMITTENT INCIDENT

Refer to [GI-44. "Intermittent Incident"](#).

>> INSPECTION END

## Component Inspection

INFOID:000000007729940

## 1.CHECK POWER STEERING PRESSURE SENSOR

1. Turn ignition switch OFF.
2. Reconnect all harness connectors disconnected.
3. Start engine and let it idle.
4. Check the voltage between ECM harness connector terminals under the following conditions.

| ECM       |          |          | Condition      | Voltage (V)      |           |
|-----------|----------|----------|----------------|------------------|-----------|
| Connector | +        | -        |                |                  |           |
|           | Terminal | Terminal |                |                  |           |
| F102      | 87       | 96       | Steering wheel | Being turned     | 0.5 - 4.5 |
|           |          |          |                | Not being turned | 0.4 - 0.8 |

Is the inspection result normal?

YES >> INSPECTION END

NO >> Replace power steering pressure sensor. Refer to [ST-76. "2WD : Exploded View"](#).



# P0603 ECM POWER SUPPLY

< DTC/CIRCUIT DIAGNOSIS >

[VQ37VHR FOR MEXICO]

## P0603 ECM POWER SUPPLY

### Description

INFOID:000000007729941

Battery voltage is supplied to the ECM even when the ignition switch is turned OFF for the ECM memory function of the DTC memory, the air-fuel ratio feedback compensation value memory, the idle air volume learning value memory, etc.

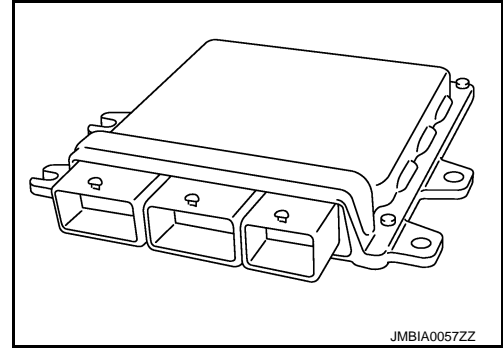

### DTC Logic

INFOID:000000007729942

#### DTC DETECTION LOGIC

| DTC No. | Trouble diagnosis name   | DTC detecting condition                            | Possible cause  |
|---------|--------------------------|--|---|
| P0603   | ECM power supply circuit | ECM back up RAM system does not function properly. | <ul style="list-style-type: none"> <li>• Harness or connectors [ECM power supply (back up) circuit is open or shorted.]</li> <li>• ECM</li> </ul> |

#### DTC CONFIRMATION PROCEDURE

##### 1. PRECONDITIONING

If DTC Confirmation Procedure has been previously conducted, always perform the following procedure before conducting the next test.

1. Turn ignition switch OFF and wait at least 10 seconds.
2. Turn ignition switch ON.
3. Turn ignition switch OFF and wait at least 10 seconds.

>> GO TO 2.

##### 2. PERFORM DTC CONFIRMATION PROCEDURE

1. Turn ignition switch ON and wait at least 10 seconds.
2. Turn ignition switch OFF and wait at least 5 minutes.
3. Turn ignition switch ON and wait at least 10 seconds.
4. Repeat steps 2 and 3 for five times.
5. Check 1st trip DTC.

Is 1st trip DTC detected?

- YES >> Go to [EC-817. "Diagnosis Procedure"](#).  
 NO >> INSPECTION END

### Diagnosis Procedure

INFOID:000000007729943

##### 1. CHECK ECM POWER SUPPLY

1. Turn ignition switch OFF.
2. Disconnect ECM harness connector.
3. Check the voltage between ECM harness connector terminals as per the following.

| ECM       |          |           |          | Voltage         |
|-----------|----------|-----------|----------|-----------------|
| +         |          | -         |          |                 |
| Connector | Terminal | Connector | Terminal |                 |
| F102      | 93       | M107      | 128      | Battery voltage |

# P0603 ECM POWER SUPPLY

[VQ37VHR FOR MEXICO]

< DTC/CIRCUIT DIAGNOSIS >

Is the inspection result normal?

YES >> GO TO 3.

NO >> GO TO 2.

## 2. DETECT MALFUNCTIONING PART

Check the following.

- Harness connectors E20, F40
- 15 A fuse (No. 51)
- IPDM E/R harness connector E5
- Harness for open or short between ECM and battery

>> Repair or replace harness or connectors.

## 3. CHECK INTERMITTENT INCIDENT

Refer to [GI-44, "Intermittent Incident"](#).

Is the inspection result normal?

YES >> GO TO 4.

NO >> Repair or replace harness or connectors.

## 4. PERFORM DTC CONFIRMATION PROCEDURE

1. Turn ignition switch ON.
2. Erase DTC.
3. **Perform DTC Confirmation Procedure.**  
See [EC-817, "DTC Logic"](#).

Is the 1st trip DTC P0603 displayed again?

YES >> GO TO 5.

NO >> INSPECTION END

## 5. REPLACE ECM

1. Replace ECM.
2. Go to [EC-653, "Work Procedure"](#).

>> INSPECTION END

P0605 ECM

DTC Logic

INFOID:000000007729944

DTC DETECTION LOGIC

A  
EC

| DTC No. | Trouble diagnosis name | DTC detecting condition |   | Possible cause |
|---------|------------------------|-------------------------|---|----------------|
| P0605   | Engine control module  | A)                      | ECM calculation function is malfunctioning.   | • ECM          |
|         |                        | B)                      | ECM EEPROM system is malfunctioning.          |                |
|         |                        | C)                      | ECM self shut-off function is malfunctioning. |                |

C  
D

DTC CONFIRMATION PROCEDURE

1. PRECONDITIONING

If DTC Confirmation Procedure has been previously conducted, always perform the following procedure before conducting the next test.

1. Turn ignition switch OFF and wait at least 10 seconds.
2. Turn ignition switch ON.
3. Turn ignition switch OFF and wait at least 10 seconds.

E  
F

>> GO TO 2.

2. PERFORM DTC CONFIRMATION PROCEDURE FOR MALFUNCTION A

1. Turn ignition switch ON.
2. Check 1st trip DTC.

Is 1st trip DTC detected?

- YES >> Go to [EC-819, "Diagnosis Procedure"](#).
- NO >> GO TO 3.

G  
H

3. PERFORM DTC CONFIRMATION PROCEDURE FOR MALFUNCTION B

1. Turn ignition switch ON and wait at least 1 second.
2. Turn ignition switch OFF, wait at least 10 seconds, and then turn it ON.
3. Check 1st trip DTC.

Is 1st trip DTC detected?

- YES >> Go to [EC-819, "Diagnosis Procedure"](#).
- NO >> GO TO 4.

I  
J

4. PERFORM DTC CONFIRMATION PROCEDURE FOR MALFUNCTION C

1. Turn ignition switch ON and wait at least 1 second.
2. Turn ignition switch OFF, wait at least 10 seconds, and then turn it ON.
3. Repeat step 2 for 32 times.
4. Check 1st trip DTC.

Is 1st trip DTC detected?

- YES >> Go to [EC-819, "Diagnosis Procedure"](#).
- NO >> INSPECTION END

K  
L

Diagnosis Procedure

INFOID:000000007729945

1. INSPECTION START

1. Turn ignition switch ON.
2. Erase DTC.
3. **Perform DTC Confirmation Procedure.**  
See [EC-819, "DTC Logic"](#).

Is the 1st trip DTC P0605 displayed again?

- YES >> GO TO 2.
- NO >> INSPECTION END

M  
N

**2.**REPLACE ECM

---

1. Replace ECM.
2. Go to [EC-653, "Work Procedure"](#).

>> INSPECTION END

< DTC/CIRCUIT DIAGNOSIS >

P0607 ECM

DTC Logic

INFOID:000000007729946

DTC DETECTION LOGIC

A  
EC

| DTC No. | Trouble diagnosis name | DTC detecting condition   | Possible cause |
|---------|------------------------|---|----------------|
| P0607   | CAN communication bus  | When detecting error during the initial diagnosis of CAN controller of ECM. | • ECM          |

C

DTC CONFIRMATION PROCEDURE

1. PERFORM DTC CONFIRMATION PROCEDURE

1. Turn ignition switch ON.
2. Check DTC.

Is DTC detected?

- YES >> Go to [EC-821, "Diagnosis Procedure"](#).
- NO >> INSPECTION END

D

E

F

Diagnosis Procedure

INFOID:000000007729947

1. INSPECTION START

1. Turn ignition switch ON.
2. Erase DTC.
3. Perform DTC Confirmation Procedure.  
See [EC-821, "DTC Logic"](#).
4. Check DTC.

Is the DTC P0607 displayed again?

- YES >> GO TO 2.
- NO >> INSPECTION END

2. REPLACE ECM

1. Replace ECM.
2. Go to [EC-653, "Work Procedure"](#).

>> INSPECTION END

G

H

I

J

K

L

M

N

O

P

# P0643 SENSOR POWER SUPPLY

< DTC/CIRCUIT DIAGNOSIS >

[VQ37VHR FOR MEXICO]

## P0643 SENSOR POWER SUPPLY

### DTC Logic

INFOID:000000007729948

### DTC DETECTION LOGIC

| DTC No. | Trouble diagnosis name            | DTC detecting condition   | Possible cause   |
|---------|-----------------------------------|---|--|
| P0643   | Sensor power supply circuit short | ECM detects that the voltage of power source for sensor is excessively low or high. | <ul style="list-style-type: none"> <li>• Harness or connectors (APP sensor 1 circuit is shorted.) (TP sensor circuit is shorted.) [CMP sensor (PHASE) (bank 1) circuit is shorted.] [Manifold absolute pressure (MAP) sensor circuit is shorted.] (PSP sensor circuit is shorted.)</li> <li>• Accelerator pedal position sensor</li> <li>• Throttle position sensor</li> <li>• Camshaft position sensor (PHASE) (bank 1)</li> <li>• Manifold absolute pressure (MAP) sensor</li> <li>• Power steering pressure sensor</li> </ul> |

### DTC CONFIRMATION PROCEDURE

#### 1. PRECONDITIONING

If DTC Confirmation Procedure has been previously conducted, always perform the following procedure before conducting the next test.

1. Turn ignition switch OFF and wait at least 10 seconds.
2. Turn ignition switch ON.
3. Turn ignition switch OFF and wait at least 10 seconds.

#### TESTING CONDITION:

Before performing the following procedure, confirm that battery voltage is more than 10 V at idle.

>> GO TO 2.

#### 2. PERFORM DTC CONFIRMATION PROCEDURE

1. Start engine and let it idle for 1 second.
2. Check DTC.

#### Is DTC detected?

- YES >> Go to [EC-822, "Diagnosis Procedure"](#).  
 NO >> INSPECTION END

### Diagnosis Procedure

INFOID:000000007729949

#### 1. CHECK GROUND CONNECTION

1. Turn ignition switch OFF.
2. Check ground connection M95. Refer to Ground Inspection in [GI-47, "Circuit Inspection"](#).

#### Is the inspection result normal?

- YES >> GO TO 2.  
 NO >> Repair or replace ground connection.

#### 2. CHECK ACCELERATOR PEDAL POSITION SENSOR 1 POWER SUPPLY CIRCUIT

1. Disconnect accelerator pedal position (APP) sensor harness connector.
2. Turn ignition switch ON.
3. Check the voltage between APP sensor harness connector and ground.

| APP sensor |          | Ground | Voltage (V) |
|------------|----------|--------|-------------|
| Connector  | Terminal |        |             |
| M153*1     | 6*1      | Ground | Approx. 5   |
| M9*2       | 5*2      |        |             |

# P0643 SENSOR POWER SUPPLY

< DTC/CIRCUIT DIAGNOSIS >

[VQ37VHR FOR MEXICO]

\*1: With ICC

\*2: Without ICC

Is the inspection result normal?

YES >> GO TO 7.

NO >> GO TO 3.

## 3.CHECK SENSOR POWER SUPPLY CIRCUITS

Check harness for short to power and short to ground, between the following terminals.

| ECM       |          | Sensor                                      |  |                                    |
|-----------|----------|---|--|------------------------------------|
| Connector | Terminal | Name  | Connector                              | Terminal                           |
| F101      | 43       | Electric throttle control actuator (bank 2) | F27                                    | 1                                  |
|           | 44       | Electric throttle control actuator (bank 1) | F67                                    | 6                                  |
| F102      | 60       | CMP sensor (PHASE) (bank 1)                 | F5                                     | 1                                  |
|           |          | Manifold absolute pressure (MAP) sensor     | F50                                    | 1                                  |
|           |          | PSP sensor                                  | F35                                    | 3                                  |
| M107      | 99       | APP sensor                                  | M153 <sup>*1</sup><br>M9 <sup>*2</sup> | 6 <sup>*1</sup><br>5 <sup>*2</sup> |

\*1: With ICC

\*2: Without ICC

Is the inspection result normal?

YES >> GO TO 4.

NO >> Repair short to ground or short to power in harness or connectors.

## 4.CHECK COMPONENTS

Check the following.

- Camshaft position sensor (PHASE) (bank 1) (Refer to [EC-786, "Component Inspection"](#).)
- Manifold absolute pressure (MAP) sensor (Refer to [EC-960, "Component Inspection"](#).)
- Power steering pressure sensor (Refer to [EC-816, "Component Inspection"](#).)

Is the inspection result normal?

YES >> GO TO 5.

NO >> Replace malfunctioning component.

## 5.CHECK TP SENSOR

Refer to [EC-718, "Component Inspection"](#).

Is the inspection result normal?

YES >> GO TO 9.

NO >> GO TO 6.

## 6.REPLACE ELECTRIC THROTTLE CONTROL ACTUATOR

1. Replace electric throttle control actuator.
2. Go to [EC-718, "Special Repair Requirement"](#).

>> INSPECTION END

## 7.CHECK APP SENSOR

Refer to [EC-920, "Component Inspection"](#).

Is the inspection result normal?

YES >> GO TO 9.

NO >> GO TO 8.

## 8.REPLACE ACCELERATOR PEDAL ASSEMBLY

1. Replace accelerator pedal assembly.
2. Go to [EC-920, "Special Repair Requirement"](#).

## P0643 SENSOR POWER SUPPLY

< DTC/CIRCUIT DIAGNOSIS >

[VQ37VHR FOR MEXICO]

---

>> INSPECTION END

### 9. CHECK INTERMITTENT INCIDENT

---

Refer to [GI-44, "Intermittent Incident"](#).

>> INSPECTION END



P0850 PNP SWITCH

Description

INFOID:000000007729950

When the selector lever position is P or N, park/neutral position (PNP) signal from the TCM is sent to ECM. ECM detects the position because the continuity of the line (the ON signal) exists.

A  
EC

DTC Logic

INFOID:000000007729951

DTC DETECTION LOGIC

| DTC No. | Trouble diagnosis name       | DTC detecting condition  | Possible cause  |
|---------|------------------------------|--|---|
| P0850   | Park/neutral position switch | The signal of the park/neutral position (PNP) signal does not change during driving after the engine is started. | <ul style="list-style-type: none"> <li>Harness or connectors [The park/neutral position (PNP) signal circuit is open or shorted.]</li> <li>TCM</li> </ul> |

C  
D  
E

DTC CONFIRMATION PROCEDURE

1.INSPECTION START

Do you have CONSULT?

Do you have CONSULT?

- YES >> GO TO 2.
- NO >> GO TO 5.

2.PRECONDITIONING

If DTC Confirmation Procedure has been previously conducted, always perform the following procedure before conducting the next test.

- Turn ignition switch OFF and wait at least 10 seconds.
- Turn ignition switch ON.
- Turn ignition switch OFF and wait at least 10 seconds.

>> GO TO 3.

3.CHECK PNP SIGNAL

 With CONSULT

- Turn ignition switch ON.
- Select "P/N POSI SW" in "DATA MONITOR" mode with CONSULT. Then check the "P/N POSI SW" signal under the following conditions.

| Position (Selector lever) | Known-good signal |
|---------------------------|-------------------|
| N or P position           | ON                |
| Except above position     | OFF               |

Is the inspection result normal?

- YES >> GO TO 4.
- NO >> Go to [EC-826. "Diagnosis Procedure"](#).

4.PERFORM DTC CONFIRMATION PROCEDURE

- Select "DATA MONITOR" mode with CONSULT.
- Start engine and warm it up to normal operating temperature.
- Maintain the following conditions for at least 50 consecutive seconds.

**CAUTION:**

**Always drive vehicle at a safe speed.**

|               |                        |
|---------------|------------------------|
| ENG SPEED     | 1,400 - 6,375 rpm      |
| COOLAN TEMP/S | More than 70°C (158°F) |

F  
G  
H  
I  
J  
K  
L  
M  
N  
O  
P

# P0850 PNP SWITCH

[VQ37VHR FOR MEXICO]

## < DTC/CIRCUIT DIAGNOSIS >

|                |                            |
|----------------|----------------------------|
| B/FUEL SCHDL   | 2.0 - 31.8 msec            |
| VHCL SPEED SE  | More than 64 km/h (40 mph) |
| Selector lever | Suitable position          |

### 4. Check 1st trip DTC.

#### Is 1st trip DTC detected?

YES >> Go to [EC-826, "Diagnosis Procedure"](#).

NO >> INSPECTION END

## 5.PERFORM COMPONENT FUNCTION CHECK

Perform component function check. Refer to [EC-826, "Component Function Check"](#).

### **NOTE:**

Use component function check the overall function of the park/neutral position (PNP) signal circuit. During this check, a 1st trip DTC might not be confirmed.

#### Is the inspection result normal?

YES >> INSPECTION END

NO >> Go to [EC-826, "Diagnosis Procedure"](#).

## Component Function Check

INFOID:000000007729952

### 1.PERFORM COMPONENT FUNCTION CHECK

1. Turn ignition switch ON.
2. Check the voltage between ECM harness connector terminals under the following conditions.

| ECM       |          |          | Condition      | Voltage (V)  |                 |
|-----------|----------|----------|----------------|--------------|-----------------|
| Connector | +        | -        |                |              |                 |
|           | Terminal | Terminal |                |              |                 |
| M107      | 109      | 128      | Selector lever | P or N       | Battery voltage |
|           |          |          |                | Except above | Approx. 0       |

#### Is the inspection result normal?

YES >> INSPECTION END

NO >> Go to [EC-826, "Diagnosis Procedure"](#).

## Diagnosis Procedure

INFOID:000000007729953

### 1.CHECK DTC WITH TCM

Refer to [TM-59, "Diagnosis Description"](#).

#### Is the inspection result normal?

YES >> GO TO 2.

NO >> Repair or replace.

### 2.CHECK STARTING SYSTEM

Turn ignition switch OFF, then turn it to START.

#### Does starter motor operate?

YES >> GO TO 3.

NO >> Check DTC with BCM. Refer to [BCS-15, "COMMON ITEM : CONSULT Function \(BCM - COMMON ITEM\)"](#).

### 3.CHECK PNP SWITCH INPUT SIGNAL CIRCUIT FOR OPEN AND SHORT

1. Turn ignition switch OFF.
2. Disconnect A/T assembly harness connector.
3. Disconnect ECM harness connector.
4. Check the continuity between A/T assembly harness connector and ECM harness connector.

# P0850 PNP SWITCH

[VQ37VHR FOR MEXICO]

< DTC/CIRCUIT DIAGNOSIS >

| A/T assembly |          | ECM       |          | Continuity |
|--------------|----------|-----------|----------|------------|
| Connector    | Terminal | Connector | Terminal |            |
| F61          | 9        | M107      | 109      | Existed    |

5. Also check harness for short to ground and short to power.

Is the inspection result normal?

YES >> GO TO 5.

NO >> GO TO 4.

## 4. DETECT MALFUNCTIONING PART

Check the following.

- Harness connectors F40, E20
- Harness connectors E106, M6
- Harness connectors M20, M30
- Harness for open or short between A/T assembly and ECM

>> Repair open circuit, short to ground or short to power in harness or connectors.

## 5. CHECK INTERMITTENT INCIDENT

Refer to [GI-44, "Intermittent Incident"](#).

>> INSPECTION END

A

EC

C

D

E

F

G

H

I

J

K

L

M

N

O

P

## P100A, P100B VVEL SYSTEM

### DTC Logic

INFOID:000000007729954

#### DTC DETECTION LOGIC

**NOTE:**

If DTC P100A or P100B is displayed with DTC P1090 or P1093, first perform the trouble diagnosis for DTC P1090 or P1093. Refer to [EC-840, "DTC Logic"](#).

| DTC No. | Trouble diagnosis name             | DTC detecting condition                  | Possible cause  |
|---------|------------------------------------|--|---|
| P100A   | VVEL response malfunction (bank 1) | Actual event response to target is poor. | <ul style="list-style-type: none"> <li>• Harness or connectors (VVEL actuator motor circuit is open or shorted.)</li> <li>• VVEL actuator motor</li> <li>• VVEL actuator sub assembly</li> <li>• VVEL ladder assembly</li> <li>• VVEL control module</li> </ul> |
| P100B   | VVEL response malfunction (bank 2) |  |   |

#### DTC CONFIRMATION PROCEDURE

##### 1. PRECONDITIONING

If DTC Confirmation Procedure has been previously conducted, always perform the following procedure before conducting the next test.

1. Turn ignition switch OFF and wait at least 10 seconds.
2. Turn ignition switch ON.
3. Turn ignition switch OFF and wait at least 10 seconds.

**TESTING CONDITION:**

**Before performing the following procedure, confirm that battery voltage is more than 10 V at idle.**

>> GO TO 2.

##### 2. PERFORM DTC CONFIRMATION PROCEDURE

1. Start engine.
2. Depress the accelerator pedal rapidly half or more under no load conditions, and then release it.
3. Wait at idle for 5 seconds or more.
4. Repeat steps 2 to 3 for three times.
5. Check 1st trip DTC.

Is DTC detected?

- YES >> Go to [EC-828, "Diagnosis Procedure"](#).  
 NO >> INSPECTION END

#### Diagnosis Procedure

INFOID:000000007729955

##### 1. CHECK GROUND CONNECTION

1. Turn ignition switch OFF.
2. Check ground connection M95. Refer to Ground Inspection in [GI-47, "Circuit Inspection"](#).

Is the inspection result normal?

- YES >> GO TO 2.  
 NO >> Repair or replace ground connection.

##### 2. VVEL ACTUATOR MOTOR OUTPUT SIGNAL CIRCUIT FOR OPEN AND SHORT

1. Disconnect VVEL control module harness connector.
2. Disconnect VVEL actuator motor harness connector.
3. Check the continuity between VVEL control module harness connector and VVEL actuator motor harness connector.

# P100A, P100B VVEL SYSTEM

< DTC/CIRCUIT DIAGNOSIS >

[VQ37VHR FOR MEXICO]

| DTC No. | VVEL control module |           |          | VVEL actuator motor |          | Continuity  |
|---------|---------------------|-----------|----------|---------------------|----------|-------------|
|         | Bank                | Connector | Terminal | Connector           | Terminal |             |
| P100A   | 1                   | E15       | 12       | F48                 | 1        | Existed     |
|         |                     |           |          |                     | 2        | Not existed |
|         |                     |           | 25       |                     | 1        | Not existed |
|         |                     |           |          |                     | 2        | Existed     |
| P100B   | 2                   |           | 2        | F49                 | 1        | Existed     |
|         |                     |           |          |                     | 2        | Not existed |
|         |                     |           | 15       |                     | 1        | Not existed |
|         |                     |           |          |                     | 2        | Existed     |

4. Also check harness for short to ground and power.

Is the inspection result normal?

YES >> GO TO 4.

NO >> GO TO 3.

## 3. DETECT MALFUNCTIONING PART

Check the following.

- Harness connectors F40, E20
- Harness for open or short between VVEL actuator motor and VVEL control module

>> Repair open circuit, short to ground or short to power in harness or connectors.

## 4. CHECK VVEL ACTUATOR MOTOR

Refer to [EC-830, "Component Inspection \(VVEL ACTUATOR MOTOR\)"](#).

Is the inspection result normal?

YES >> GO TO 6.

NO >> GO TO 5.

## 5. REPLACE VVEL ACTUATOR SUB ASSEMBLY

1. Replace VVEL actuator sub assembly.
2. Go to [EC-831, "Special Repair Requirement"](#).

>> INSPECTION END

## 6. CHECK INTERMITTENT INCIDENT

Refer to [GI-44, "Intermittent Incident"](#).

Is the inspection result normal?

YES >> GO TO 7.

NO >> Repair or replace.

## 7. REPLACE VVEL CONTROL MODULE

1. Replace VVEL control module.
2. Go to [EC-654, "Work Procedure"](#).

>> GO TO 8.

## 8. PERFORM DTC CONFIRMATION PROCEDURE

1. Turn ignition switch ON.
2. Erase DTC.
3. Perform DTC Confirmation Procedure.  
See [EC-828, "DTC Logic"](#).

Is the DTC P100A or P100B displayed again?

YES >> GO TO 9.

# P100A, P100B VVEL SYSTEM

[VQ37VHR FOR MEXICO]

< DTC/CIRCUIT DIAGNOSIS >

NO >> INSPECTION END

## 9. CHECK VVEL ACTUATOR SUB ASSEMBLY

Refer to [EC-830, "Component Inspection \(VVEL ACTUATOR SUB ASSEMBLY\)"](#).

Is the inspection result normal?

YES >> GO TO 11.

NO >> GO TO 10.

## 10. REPLACE VVEL ACTUATOR SUB ASSEMBLY

1. Replace VVEL actuator sub assembly.
2. Go to [EC-831, "Special Repair Requirement"](#).

>> INSPECTION END

## 11. CHECK VVEL LADDER ASSEMBLY

Refer to [EM-106, "Inspection"](#).

Is the inspection result normal?

YES >> GO TO 13.

NO >> GO TO 12.

## 12. REPLACE CYLINDER HEAD, VVEL LADDER ASSEMBLY AND VVEL ACTUATOR SUB ASSEMBLY

1. Replace cylinder head, VVEL ladder assembly and VVEL actuator sub assembly.
2. Go to [EC-831, "Special Repair Requirement"](#).

>> INSPECTION END

## 13. CHECK INTERMITTENT INCIDENT

Refer to [GI-44, "Intermittent Incident"](#).

>> INSPECTION END

## Component Inspection (VVEL ACTUATOR MOTOR)

INFOID:000000007729956

### 1. CHECK VVEL ACTUATOR MOTOR

1. Turn ignition switch OFF.
2. Disconnect VVEL actuator motor harness connector.
3. Check resistance between VVEL actuator motor terminals as follows.

| VVEL actuator motor | Resistance          |
|---------------------|---------------------|
| Terminal            |                     |
| 1 and 2             | 16 $\Omega$ or less |

Is the inspection result normal?

YES >> INSPECTION END

NO >> GO TO 2.

### 2. REPLACE VVEL ACTUATOR SUB ASSEMBLY

1. Replace VVEL actuator sub assembly.
2. Go to [EC-831, "Special Repair Requirement"](#).

>> INSPECTION END

## Component Inspection (VVEL ACTUATOR SUB ASSEMBLY)

INFOID:000000007729957

### 1. CHECK VVEL ACTUATOR SUB ASSEMBLY

1. Turn ignition switch OFF.
2. Remove VVEL actuator sub assembly. Refer to [EM-97, "Disassembly and Assembly"](#).

# P100A, P100B VVEL SYSTEM

[VQ37VHR FOR MEXICO]

< DTC/CIRCUIT DIAGNOSIS >

3. Turn the ball screw shaft to check that it works smoothly.

Is the inspection result normal?

YES >> INSPECTION END

NO >> GO TO 2.

## 2.REPLACE VVEL ACTUATOR SUB ASSEMBLY

1. Replace VVEL actuator sub assembly.

2. Go to [EC-831](#). "Special Repair Requirement".

>> INSPECTION END

## Special Repair Requirement

INFOID:000000007729958

## 1.PERFORM VVEL CONTROL SHAFT POSITION SENSOR ADJUSTMENT

Refer to [EC-660](#). "Work Procedure".

>> GO TO 2.

## 2.PERFORM IDLE AIR VOLUME LEARNING

Refer to [EC-658](#). "Work Procedure".

>> END

A

EC

C

D

E

F

G

H

I

J

K

L

M

N

O

P

# P1087, P1088 VVEL SYSTEM

< DTC/CIRCUIT DIAGNOSIS >

[VQ37VHR FOR MEXICO]

## P1087, P1088 VVEL SYSTEM

### DTC Logic

INFOID:000000007729959

### DTC DETECTION LOGIC

**NOTE:**

If DTC P1087 or P1088 is displayed with DTC P1090 or P1093.

Perform the trouble diagnosis for DTC P1090 or P1093. Refer to [EC-836, "DTC Logic"](#).

| DTC No. | Trouble diagnosis name                      | DTC detecting condition                                | Possible cause  |
|---------|---|--|---|
| P1087   | VVEL small event angle malfunction (bank 1) | The event angle of VVEL control shaft is always small. | <ul style="list-style-type: none"><li>• Harness or connectors (VVEL actuator motor circuit is open or shorted.)</li><li>• VVEL actuator motor</li><li>• VVEL actuator sub assembly</li><li>• VVEL ladder assembly</li><li>• VVEL control module</li></ul> |
| P1088   | VVEL small event angle malfunction (bank 2) |  |   |



# P1089, P1092 VVEL CONTROL SHAFT POSITION SENSOR

< DTC/CIRCUIT DIAGNOSIS >

[VQ37VHR FOR MEXICO]

## P1089, P1092 VVEL CONTROL SHAFT POSITION SENSOR

### DTC Logic

INFOID:000000007729960

### DTC DETECTION LOGIC

#### NOTE:

If DTC P1089 or P1092 is displayed with DTC P1608, first perform the trouble diagnosis for DTC P1608. Refer to [EC-912. "DTC Logic"](#).

| DTC No. | Trouble diagnosis name                              | DTC detecting condition  | Possible cause  |
|---------|---|--|---|
| P1089   | VVEL control shaft position sensor (bank 1) circuit | <ul style="list-style-type: none"><li>• An excessively low voltage from the sensor is sent to VVEL control module.</li><li>• An excessively high voltage from the sensor is sent to VVEL control module.</li><li>• Rationally incorrect voltage is sent to VVEL control module compared with the signals from VVEL control shaft position sensor 1 and VVEL control shaft position sensor 2.</li></ul> | <ul style="list-style-type: none"><li>• Harness or connectors (VVEL control shaft position sensor circuit is open or shorted.)</li><li>• VVEL control shaft position sensor</li><li>• VVEL control module</li></ul> |
| P1092   | VVEL control shaft position sensor (bank 2) circuit |  |   |

### DTC CONFIRMATION PROCEDURE

#### 1. PRECONDITIONING

If DTC Confirmation Procedure has been previously conducted, always perform the following procedure before conducting the next test.

1. Turn ignition switch OFF and wait at least 10 seconds.
2. Turn ignition switch ON.
3. Turn ignition switch OFF and wait at least 10 seconds.

#### TESTING CONDITION:

Before performing the following procedure, confirm that battery voltage is more than 10 V at idle.

>> GO TO 2.

#### 2. PERFORM DTC CONFIRMATION PROCEDURE

1. Start engine and let it idle for 1 second.
2. Check DTC.

#### Is DTC detected?

- YES >> Go to [EC-833. "Diagnosis Procedure"](#).  
NO >> INSPECTION END

### Diagnosis Procedure

INFOID:000000007729961

#### 1. CHECK GROUND CONNECTION

1. Turn ignition switch OFF.
2. Check ground connection M95. Refer to Ground Inspection in [GI-47. "Circuit Inspection"](#).

#### Is the inspection result normal?

- YES >> GO TO 2.  
NO >> Repair or replace ground connection.

#### 2. VVEL CONTROL SHAFT POSITION SENSOR POWER SUPPLY CIRCUIT

1. Disconnect VVEL control shaft position sensor harness connector.
2. Turn ignition switch ON.
3. Check the voltage between VVEL control shaft position sensor harness connector and ground.

# P1089, P1092 VVEL CONTROL SHAFT POSITION SENSOR

< DTC/CIRCUIT DIAGNOSIS >

[VQ37VHR FOR MEXICO]

| DTC No. | VVEL control shaft position sensor |           |          | Ground | Voltage (V) |
|---------|------------------------------------|-----------|----------|--------|-------------|
|         | Bank                               | Connector | Terminal |        |             |
| P1089   | 1                                  | F46       | 3        | Ground | Approx. 5   |
|         |                                    |           | 6        |        |             |
| P1092   | 2                                  | F47       | 3        |        |             |
|         |                                    |           | 6        |        |             |

Is the inspection result normal?

- YES >> GO TO 4.  
 NO >> GO TO 3.

### 3. DETECT MALFUNCTIONING PART

Check the following.

- Harness connectors F40, E20
- Harness for open or short between VVEL control shaft position sensor and VVEL control module

>> Repair open circuit, short to ground or short to power in harness or connectors.

### 4. CHECK VVEL CONTROL SHAFT POSITION SENSOR GROUND CIRCUIT FOR OPEN AND SHORT

1. Turn ignition switch OFF.
2. Disconnect VVEL control module harness connector.
3. Check the continuity between VVEL control shaft position sensor harness connector and VVEL control module harness connector.

| DTC No. | VVEL control shaft position sensor |           |          | VVEL control module |          | Continuity |
|---------|------------------------------------|-----------|----------|---------------------|----------|------------|
|         | Bank                               | Connector | Terminal | Connector           | Terminal |            |
| P1089   | 1                                  | F46       | 2        | E15                 | 4        | Existed    |
|         |                                    |           | 5        |                     | 17       |            |
| P1092   | 2                                  | F47       | 2        |                     | 6        |            |
|         |                                    |           | 5        |                     | 19       |            |

4. Also check harness for short to ground and power.

Is the inspection result normal?

- YES >> GO TO 6.  
 NO >> GO TO 5.

### 5. DETECT MALFUNCTIONING PART

Check the following.

- Harness connectors F40, E20
- Harness for open or short between VVEL control shaft position sensor and VVEL control module

>> Repair open circuit, short to ground or short to power in harness or connectors.

### 6. VVEL CONTROL SHAFT POSITION SENSOR INPUT SIGNAL CIRCUIT FOR OPEN AND SHORT

1. Check the continuity between VVEL control shaft position sensor harness connector and VVEL control module harness connector.

| DTC No. | VVEL control shaft position sensor |           |          | VVEL control module |          | Continuity |
|---------|------------------------------------|-----------|----------|---------------------|----------|------------|
|         | Bank                               | Connector | Terminal | Connector           | Terminal |            |
| P1089   | 1                                  | F46       | 1        | E15                 | 3        | Existed    |
|         |                                    |           | 4        |                     | 16       |            |
| P1092   | 2                                  | F47       | 1        |                     | 5        |            |
|         |                                    |           | 4        |                     | 18       |            |

# P1089, P1092 VVEL CONTROL SHAFT POSITION SENSOR

[VQ37VHR FOR MEXICO]

< DTC/CIRCUIT DIAGNOSIS >

2. Also check harness for short to ground and power.

Is the inspection result normal?

YES >> GO TO 8.

NO >> GO TO 7.

## 7. DETECT MALFUNCTIONING PART

Check the following.

- Harness connectors F40, E20
- Harness for open or short between VVEL control shaft position sensor and VVEL control module

>> Repair open circuit, short to ground or short to power in harness or connectors.

## 8. CHECK INTERMITTENT INCIDENT

Refer to [GI-44. "Intermittent Incident"](#).

Is the inspection result normal?

YES >> GO TO 9.

NO >> Repair or replace.

## 9. REPLACE VVEL CONTROL MODULE

1. Replace VVEL control module.
2. Go to [EC-654. "Work Procedure"](#).

>> GO TO 10.

## 10. PERFORM DTC CONFIRMATION PROCEDURE

1. Turn ignition switch ON.
2. Erase DTC.
3. Perform DTC Confirmation Procedure.  
See [EC-833. "DTC Logic"](#).

Is the DTC P1089 or P1092 displayed again?

YES >> GO TO 11.

NO >> INSPECTION END

## 11. REPLACE VVEL ACTUATOR SUB ASSEMBLY

1. Replace VVEL actuator sub assembly.
2. Go to [EC-835. "Special Repair Requirement"](#).

>> INSPECTION END

## Special Repair Requirement

INFOID:000000007729962

### 1. PERFORM VVEL CONTROL SHAFT POSITION SENSOR ADJUSTMENT

Refer to [EC-660. "Work Procedure"](#).

>> GO TO 2.

### 2. PERFORM IDLE AIR VOLUME LEARNING

Refer to [EC-658. "Work Procedure"](#).

>> END

# P1090, P1093 VVEL ACTUATOR MOTOR

< DTC/CIRCUIT DIAGNOSIS >

[VQ37VHR FOR MEXICO]

## P1090, P1093 VVEL ACTUATOR MOTOR

### DTC Logic

INFOID:000000007729963

#### DTC DETECTION LOGIC

##### NOTE:

If DTC P1090 or P1093 is displayed with DTC P1091, first perform the trouble diagnosis for DTC P1091. Refer to [EC-840, "DTC Logic"](#).

| DTC No. | Trouble diagnosis name           | DTC detecting condition  | Possible cause  |
|---------|----------------------------------|--|---|
| P1090   | VVEL system performance (bank 1) | <ul style="list-style-type: none"><li>Event angle difference between the actual and the target is detected.</li><li>Abnormal current is sent to VVEL actuator motor.</li></ul> | <ul style="list-style-type: none"><li>Harness or connectors (VVEL actuator motor circuit is open or shorted.)</li><li>VVEL actuator motor</li><li>VVEL actuator sub assembly</li><li>VVEL ladder assembly</li><li>VVEL control module</li></ul> |
| P1093   | VVEL system performance (bank 2) |  |   |

#### DTC CONFIRMATION PROCEDURE

##### 1. PRECONDITIONING

If DTC Confirmation Procedure has been previously conducted, always perform the following procedure before conducting the next test.

- Turn ignition switch OFF and wait at least 10 seconds.
- Turn ignition switch ON.
- Turn ignition switch OFF and wait at least 10 seconds.

##### TESTING CONDITION:

Before performing the following procedure, confirm that battery voltage is more than 10 V at idle.

>> GO TO 2.

##### 2. PERFORM DTC CONFIRMATION PROCEDURE

- Start engine and let it idle for 10 second.
- Keep the engine speed at about 3,500 rpm for at least 10 seconds under no load.
- Check DTC.

Is DTC detected?

- YES >> Go to [EC-836, "Diagnosis Procedure"](#).  
NO >> INSPECTION END

#### Diagnosis Procedure

INFOID:000000007729964

##### 1. CHECK GROUND CONNECTION

- Turn ignition switch OFF.
- Check ground connection M95. Refer to Ground Inspection in [GI-47, "Circuit Inspection"](#).

Is the inspection result normal?

- YES >> GO TO 2.  
NO >> Repair or replace ground connection.

##### 2. VVEL ACTUATOR MOTOR OUTPUT SIGNAL CIRCUIT FOR OPEN AND SHORT

- Disconnect VVEL control module harness connector.
- Disconnect VVEL actuator motor harness connector.
- Check the continuity between VVEL control module harness connector and VVEL actuator motor harness connector.

# P1090, P1093 VVEL ACTUATOR MOTOR

< DTC/CIRCUIT DIAGNOSIS >

[VQ37VHR FOR MEXICO]

| DTC No. | VVEL control module |           |          | VVEL actuator motor |          | Continuity  |
|---------|---------------------|-----------|----------|---------------------|----------|-------------|
|         | Bank                | Connector | Terminal | Connector           | Terminal |             |
| P1090   | 1                   | E15       | 12       | F48                 | 1        | Existed     |
|         |                     |           |          |                     | 2        | Not existed |
|         |                     |           | 25       |                     | 1        | Not existed |
|         |                     |           |          |                     | 2        | Existed     |
| P1093   | 2                   | E15       | 2        | F49                 | 1        | Existed     |
|         |                     |           |          |                     | 2        | Not existed |
|         |                     |           | 15       |                     | 1        | Not existed |
|         |                     |           |          |                     | 2        | Existed     |

4. Also check harness for short to ground and power.

Is the inspection result normal?

YES >> GO TO 4.

NO >> GO TO 3.

## 3. DETECT MALFUNCTIONING PART

Check the following.

- Harness connectors F40, E20
- Harness for open or short between VVEL actuator motor and VVEL control module

>> Repair open circuit, short to ground or short to power in harness or connectors.

## 4. CHECK VVEL ACTUATOR MOTOR

Refer to [EC-838, "Component Inspection \(VVEL ACTUATOR MOTOR\)"](#).

Is the inspection result normal?

YES >> GO TO 6.

NO >> GO TO 5.

## 5. REPLACE VVEL ACTUATOR SUB ASSEMBLY

1. Replace VVEL actuator sub assembly.
2. Go to [EC-839, "Special Repair Requirement"](#).

>> INSPECTION END

## 6. CHECK INTERMITTENT INCIDENT

Refer to [GI-44, "Intermittent Incident"](#).

Is the inspection result normal?

YES >> GO TO 7.

NO >> Repair or replace.

## 7. REPLACE VVEL CONTROL MODULE

1. Replace VVEL control module.
2. Go to [EC-654, "Work Procedure"](#).

>> GO TO 8.

## 8. PERFORM DTC CONFIRMATION PROCEDURE

1. Turn ignition switch ON.
2. Erase DTC.
3. Perform DTC Confirmation Procedure.  
See [EC-836, "DTC Logic"](#).

Is the DTC P1090 or P1093 displayed again?

YES >> GO TO 9.

# P1090, P1093 VVEL ACTUATOR MOTOR

< DTC/CIRCUIT DIAGNOSIS >

[VQ37VHR FOR MEXICO]

NO >> INSPECTION END

## 9. CHECK VVEL ACTUATOR SUB ASSEMBLY

Refer to [EC-838, "Component Inspection \(VVEL ACTUATOR SUB ASSEMBLY\)"](#).

Is the inspection result normal?

YES >> GO TO 11.

NO >> GO TO 10.

## 10. REPLACE VVEL ACTUATOR SUB ASSEMBLY

1. Replace VVEL actuator sub assembly.
2. Go to [EC-839, "Special Repair Requirement"](#).

>> INSPECTION END

## 11. CHECK VVEL LADDER ASSEMBLY

Refer to [EM-106, "Inspection"](#).

Is the inspection result normal?

YES >> GO TO 13.

NO >> GO TO 12.

## 12. REPLACE CYLINDER HEAD, VVEL LADDER ASSEMBLY AND VVEL ACTUATOR SUB ASSEMBLY

1. Replace cylinder head, VVEL ladder assembly and VVEL actuator sub assembly.
2. Go to [EC-839, "Special Repair Requirement"](#).

>> INSPECTION END

## 13. CHECK INTERMITTENT INCIDENT

Refer to [GI-44, "Intermittent Incident"](#).

>> INSPECTION END

## Component Inspection (VVEL ACTUATOR MOTOR)

INFOID:000000007729965

### 1. CHECK VVEL ACTUATOR MOTOR

1. Turn ignition switch OFF.
2. Disconnect VVEL actuator motor harness connector.
3. Check resistance between VVEL actuator motor terminals as follows.

| VVEL actuator motor | Resistance   |
|---------------------|--------------|
| Terminal            |              |
| 1 and 2             | 16 Ω or less |

Is the inspection result normal?

YES >> INSPECTION END

NO >> GO TO 2.

### 2. REPLACE VVEL ACTUATOR SUB ASSEMBLY

1. Replace VVEL actuator sub assembly.
2. Go to [EC-839, "Special Repair Requirement"](#).

>> INSPECTION END

## Component Inspection (VVEL ACTUATOR SUB ASSEMBLY)

INFOID:000000007729966

### 1. CHECK VVEL ACTUATOR SUB ASSEMBLY

1. Turn ignition switch OFF.
2. Remove VVEL actuator sub assembly. Refer to [EM-97, "Disassembly and Assembly"](#).

# P1090, P1093 VVEL ACTUATOR MOTOR

< DTC/CIRCUIT DIAGNOSIS >

[VQ37VHR FOR MEXICO]

3. Turn the ball screw shaft to check that it works smoothly.

Is the inspection result normal?

YES >> INSPECTION END

NO >> GO TO 2.

## 2.REPLACE VVEL ACTUATOR SUB ASSEMBLY

1. Replace VVEL actuator sub assembly.

2. Go to [EC-839](#). "Special Repair Requirement".

>> INSPECTION END

## Special Repair Requirement

INFOID:000000007729967

## 1.PERFORM VVEL CONTROL SHAFT POSITION SENSOR ADJUSTMENT

Refer to [EC-660](#). "Work Procedure".

>> GO TO 2.

## 2.PERFORM IDLE AIR VOLUME LEARNING

Refer to [EC-658](#). "Work Procedure".

>> END

A

EC

C

D

E

F

G

H

I

J

K

L

M

N

O

P

# P1091 VVEL ACTUATOR MOTOR RELAY

< DTC/CIRCUIT DIAGNOSIS >

[VQ37VHR FOR MEXICO]

## P1091 VVEL ACTUATOR MOTOR RELAY

### DTC Logic

INFOID:000000007729968

### DTC DETECTION LOGIC

| DTC No. | Trouble diagnosis name            | DTC detecting condition   | Possible cause   |
|---------|-----------------------------------|---|--|
| P1091   | VVEL actuator motor relay circuit | <ul style="list-style-type: none"> <li>VVEL control module detects the VVEL actuator motor relay is stuck OFF.</li> <li>VVEL control module detects the VVEL actuator motor relay is stuck ON.</li> </ul> | <ul style="list-style-type: none"> <li>Harness or connectors (VVEL actuator motor relay circuit is open or shorted.) (Abort circuit is open or shorted.)</li> <li>VVEL actuator motor relay</li> <li>VVEL control module</li> <li>ECM</li> </ul> |

### DTC CONFIRMATION PROCEDURE

#### 1. PRECONDITIONING

If DTC Confirmation Procedure has been previously conducted, always perform the following procedure before conducting the next test.

1. Turn ignition switch OFF and wait at least 10 seconds.
2. Turn ignition switch ON.
3. Turn ignition switch OFF and wait at least 10 seconds.

#### TESTING CONDITION:

Before performing the following procedure, confirm that battery voltage is more than 10 V at idle.

>> GO TO 2.

#### 2. PERFORM DTC CONFIRMATION PROCEDURE

1. Turn ignition switch ON and wait at least 1 seconds.
2. Turn ignition switch OFF and wait at least 10 seconds.
3. Turn ignition switch ON and wait at least 1 seconds.
4. Check DTC.

#### Is DTC detected?

- YES >> Go to [EC-840, "Diagnosis Procedure"](#).  
 NO >> INSPECTION END

### Diagnosis Procedure

INFOID:000000007729969

#### 1. VVEL ACTUATOR MOTOR RELAY POWER SUPPLY CIRCUIT-I

1. Turn ignition switch OFF.
2. Disconnect VVEL actuator motor relay.
3. Check the voltage between VVEL actuator motor relay harness connector and ground.

| VVEL actuator motor relay |          | Ground | Voltage         |
|---------------------------|----------|--------|-----------------|
| Connector                 | Terminal |        |                 |
| E16                       | 1        | Ground | Battery voltage |
|                           | 5        |        |                 |

#### Is the inspection result normal?

- YES >> GO TO 3.  
 NO >> GO TO 2.

#### 2. DETECT MALFUNCTIONING PART

Check the following.

- 50 A fusible link (letter G)
- Harness for open or short between VVEL actuator motor relay and battery



# P1091 VVEL ACTUATOR MOTOR RELAY

< DTC/CIRCUIT DIAGNOSIS >

[VQ37VHR FOR MEXICO]

>> Repair open circuit, short to ground or short to power in harness or connectors.

## 3.VVEL ACTUATOR MOTOR RELAY POWER SUPPLY CIRCUIT-II

1. Disconnect VVEL control module harness connector.
2. Check the continuity between VVEL actuator motor relay harness connector and VVEL control module harness connector.

| VVEL control module |          | VVEL actuator motor relay |          | Continuity |
|---------------------|----------|---------------------------|----------|------------|
| Connector           | Terminal | Connector                 | Terminal |            |
| E15                 | 23       | E16                       | 2        | Existed    |

3. Also check harness for short to ground and power.

Is the inspection result normal?

YES >> GO TO 4.

NO >> Repair open circuit, short to ground or short to power in harness or connectors.

## 4.VVEL ACTUATOR MOTOR RELAY INPUT SIGNAL CIRCUIT FOR OPEN AND SHORT

1. Check the continuity between VVEL actuator motor relay harness connector and VVEL control module harness connector.

| VVEL control module |           |          | VVEL actuator motor relay |          | Continuity |
|---------------------|-----------|----------|---------------------------|----------|------------|
| Bank                | Connector | Terminal | Connector                 | Terminal |            |
| 1                   | E15       | 13       | E16                       | 3        | Existed    |
| 2                   |           | 1        |                           |          |            |

2. Also check harness for short to ground and power.

Is the inspection result normal?

YES >> GO TO 5.

NO >> Repair open circuit, short to ground or short to power in harness or connectors.

## 5.CHECK VVEL ACTUATOR MOTOR RELAY

Refer to [EC-842. "Component Inspection"](#).

Is the inspection result normal?

YES >> GO TO 6.

NO >> Replace VVEL actuator motor relay.

## 6.CHECK ABORT CIRCUIT FOR OPEN AND SHORT

1. Disconnect ECM harness connector.
2. Check the continuity between VVEL control module harness connector and ECM harness connector.

| VVEL control module |          | ECM       |          | Continuity |
|---------------------|----------|-----------|----------|------------|
| Connector           | Terminal | Connector | Terminal |            |
| E15                 | 21       | F101      | 28       | Existed    |

3. Also check harness for short to ground and power.

Is the inspection result normal?

YES >> GO TO 8.

NO >> GO TO 7.

## 7.DETECT MALFUNCTIONING PART

Check the following.

- Harness connector E20, F40
- Harness for open or short between ECM and VVEL control module

>> Repair open circuit, short to ground or short to power in harness or connectors.

## 8.CHECK INTERMITTENT INCIDENT

# P1091 VVEL ACTUATOR MOTOR RELAY

[VQ37VHR FOR MEXICO]

< DTC/CIRCUIT DIAGNOSIS >

Refer to [GI-44, "Intermittent Incident"](#).

Is the inspection result normal?

YES >> GO TO 9.

NO >> Repair or replace.

## 9. REPLACE VVEL CONTROL MODULE

1. Replace VVEL control module.
2. Go to [EC-654, "Work Procedure"](#).

>> GO TO 10.

## 10. PERFORM DTC CONFIRMATION PROCEDURE

1. Turn ignition switch ON.
2. Erase DTC.
3. Perform DTC Confirmation Procedure.  
See [EC-840, "DTC Logic"](#).

Is the DTC P1091 displayed again?

YES >> GO TO 11.

NO >> INSPECTION END

## 11. REPLACE ECM

1. Replace ECM.
2. Go to [EC-653, "Work Procedure"](#).

>> INSPECTION END

## Component Inspection

INFOID:000000007729970

### 1. CHECK VVEL ACTUATOR MOTOR RELAY

1. Turn ignition switch OFF.
2. Remove VVEL actuator motor relay.
3. Check the continuity between VVEL actuator motor relay terminals under the following conditions.

| Terminal | Condition  | Continuity  |
|----------|--|-------------|
| 3 and 5  | 12 V direct current supply between terminals 1 and 2 | Existed     |
|          | No current supply                                    | Not existed |

Is the inspection result normal?

YES >> INSPECTION END

NO >> Replace VVEL actuator motor relay.

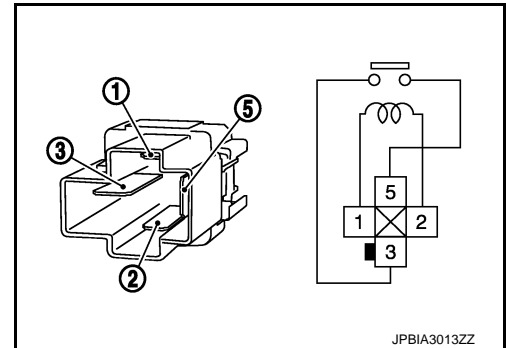

JPBIA3013ZZ

# P1211 TCS CONTROL UNIT

< DTC/CIRCUIT DIAGNOSIS >

[VQ37VHR FOR MEXICO]

## P1211 TCS CONTROL UNIT

### Description

INFOID:000000007729972

The malfunction information related to TCS is transferred via the CAN communication line from “ABS actuator and electric unit (control unit)” to ECM.

**Be sure to erase the malfunction information such as DTC not only for “ABS actuator and electric unit (control unit)” but also for ECM after TCS related repair.**

### DTC Logic

INFOID:000000007729973

### DTC DETECTION LOGIC

**Freeze frame data is not stored in the ECM for this self-diagnosis.**

| DTC No. | Trouble diagnosis name | DTC detecting condition  | Possible cause  |
|---------|------------------------|--|---|
| P1211   | TCS control unit       | ECM receives malfunction information from “ABS actuator and electric unit (control unit)”. | <ul style="list-style-type: none"><li>• ABS actuator and electric unit (control unit)</li><li>• TCS related parts</li></ul> |

### DTC CONFIRMATION PROCEDURE

#### 1. PRECONDITIONING

#### TESTING CONDITION:

**Before performing the following procedure, confirm that battery voltage is more than 10.5 V at idle.**

>> GO TO 2.

#### 2. PERFORM DTC CONFIRMATION PROCEDURE

1. Start engine and let it idle for at least 60 seconds.
2. Check 1st trip DTC.

Is 1st trip DTC detected?

- YES >> [EC-843, "Diagnosis Procedure"](#)  
NO >> INSPECTION END

### Diagnosis Procedure

INFOID:000000007729974

Go to [BRC-55, "Work Flow"](#).

A  
EC  
C  
D  
E  
F  
G  
H  
I  
J  
K  
L  
M  
N  
O  
P

# P1212 TCS COMMUNICATION LINE

< DTC/CIRCUIT DIAGNOSIS >

[VQ37VHR FOR MEXICO]

## P1212 TCS COMMUNICATION LINE

### Description

INFOID:000000007729975

This CAN communication line is used to control the smooth engine operation during the TCS operation. Pulse signals are exchanged between ECM and “ABS actuator and electric unit (control unit)”.

**Be sure to erase the malfunction information such as DTC not only for “ABS actuator and electric unit (control unit)” but also for ECM after TCS related repair.**

### DTC Logic

INFOID:000000007729976

#### DTC DETECTION LOGIC

##### NOTE:

- If DTC P1212 is displayed with DTC UXXXX, first perform the trouble diagnosis for DTC UXXXX.
- If DTC P1212 is displayed with DTC P0607, first perform the trouble diagnosis for DTC P0607. Refer to [EC-821, "DTC Logic"](#).

**Freeze frame data is not stored in the ECM for this self-diagnosis.**

| DTC No. | Trouble diagnosis name | DTC detecting condition   | Possible cause   |
|---------|------------------------|---|--|
| P1212   | TCS communication line | ECM cannot receive the information from “ABS actuator and electric unit (control unit)” continuously. | <ul style="list-style-type: none"><li>• Harness or connectors (The CAN communication line is open or shorted.)</li><li>• ABS actuator and electric unit (control unit)</li><li>• Dead (Weak) battery</li></ul> |

#### DTC CONFIRMATION PROCEDURE

##### 1. PRECONDITIONING

##### TESTING CONDITION:

**Before performing the following procedure, confirm that battery voltage is more than 10.5 V at idle.**

>> GO TO 2.

##### 2. PERFORM DTC CONFIRMATION PROCEDURE

1. Start engine and let it idle for at least 10 seconds.
2. Check 1st trip DTC.

Is 1st trip DTC detected?

- YES >> Go to [EC-844, "Diagnosis Procedure"](#).  
NO >> INSPECTION END

### Diagnosis Procedure

INFOID:000000007729977

Go to [BRC-55, "Work Flow"](#).

# P1217 ENGINE OVER TEMPERATURE

< DTC/CIRCUIT DIAGNOSIS >

[VQ37VHR FOR MEXICO]

## P1217 ENGINE OVER TEMPERATURE

### DTC Logic

INFOID:000000007729978

#### DTC DETECTION LOGIC

##### NOTE:

- If DTC P1217 is displayed with DTC UXXXX, first perform the trouble diagnosis for DTC UXXXX.
- If DTC P1217 is displayed with DTC P0607, first perform the trouble diagnosis for DTC P0607. Refer to [EC-821, "DTC Logic"](#).

If the cooling fan or another component in the cooling system malfunctions, engine coolant temperature will rise.

When the engine coolant temperature reaches an abnormally high temperature condition, a malfunction is indicated.

| DTC No. | Trouble diagnosis name             | DTC detecting condition  | Possible cause  |
|---------|------------------------------------|--|---|
| P1217   | Engine over temperature (Overheat) | <ul style="list-style-type: none"><li>• Cooling fan does not operate properly (Overheat).</li><li>• Cooling fan system does not operate properly (Overheat).</li><li>• Engine coolant was not added to the system using the proper filling method.</li><li>• Engine coolant is not within the specified range.</li></ul> | <ul style="list-style-type: none"><li>• Harness or connectors (The cooling fan circuit is open or shorted.)</li><li>• IPDM E/R</li><li>• Cooling fan control module</li><li>• Cooling fan motor</li><li>• Radiator hose</li><li>• Radiator</li><li>• Radiator cap</li><li>• Water pump</li><li>• Thermostat</li></ul> |

##### CAUTION:

When a malfunction is indicated, always replace the coolant. Refer to [CO-8, "Draining"](#) and [CO-9, "Refilling"](#). Also, replace the engine oil. Refer to [LU-9, "Draining"](#) and [LU-9, "Refilling"](#).

1. Fill radiator with coolant up to specified level with a filling speed of 2 liters per minute. Always use coolant with the proper mixture ratio. Refer to [MA-17, "FOR NORTH AMERICA : Anti-Freeze Coolant Mixture Ratio"](#).
2. After refilling coolant, run engine to ensure that no water-flow noise is emitted.

#### DTC CONFIRMATION PROCEDURE

##### 1. PERFORM COMPONENT FUNCTION CHECK

Perform component function check. Refer to [EC-845, "Component Function Check"](#).

##### NOTE:

Use component function check to check the overall function of the cooling fan. During this check, a DTC might not be confirmed.

Is the inspection result normal?

YES >> INSPECTION END

NO >> Go to [EC-846, "Diagnosis Procedure"](#).

#### Component Function Check

INFOID:000000007729979

##### 1. PERFORM COMPONENT FUNCTION CHECK-I

##### WARNING:

Never remove the radiator cap when the engine is hot. Serious burns could be caused by high pressure fluid escaping from the radiator.

Wrap a thick cloth around cap. Carefully remove the cap by turning it a quarter turn to allow built-up pressure to escape. Then turn the cap all the way off.

# P1217 ENGINE OVER TEMPERATURE

< DTC/CIRCUIT DIAGNOSIS >

[VQ37VHR FOR MEXICO]

Check the coolant level in the reservoir tank and radiator.

**Allow engine to cool before checking coolant level.**

Is the coolant level in the reservoir tank and/or radiator below the proper range?

- YES >> Go to [EC-846, "Diagnosis Procedure"](#).  
NO >> GO TO 2.

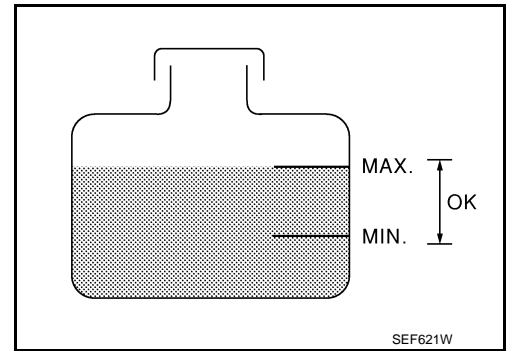

## 2.PERFORM COMPONENT FUNCTION CHECK-II

Confirm whether customer filled the coolant or not.

Did customer fill the coolant?

- YES >> Go to [EC-846, "Diagnosis Procedure"](#).  
NO >> GO TO 3.

## 3.PERFORM COMPONENT FUNCTION CHECK-III

### With CONSULT

1. Turn ignition switch ON.
2. Perform "FAN DUTY CONTROL" in "ACTIVE TEST" mode with CONSULT.
3. Make sure that cooling fan speed varies according to the percentage.

### Without CONSULT

Perform IPDM E/R auto active test and check cooling fan motors operation, refer to [PCS-12, "Diagnosis Description"](#).

Is the inspection result normal?

- YES >> INSPECTION END  
NO >> Go to [EC-846, "Diagnosis Procedure"](#).

## Diagnosis Procedure

INFOID:000000007729980

## 1.CHECK COOLING FAN OPERATION

### With CONSULT

1. Turn ignition switch ON.
2. Perform "FAN DUTY CONTROL" in "ACTIVE TEST" mode with CONSULT.
3. Make sure that cooling fan speed varies according to the percentage.

### Without CONSULT

1. Perform IPDM E/R auto active test and check cooling fan motors operation, refer to [PCS-12, "Diagnosis Description"](#).
2. Make sure that cooling fan operates.

Is the inspection result normal?

- YES >> GO TO 2.  
NO >> Go to [EC-939, "Diagnosis Procedure"](#).

## 2.CHECK COOLING SYSTEM FOR LEAK-I

Check cooling system for leak. Refer to [CO-8, "Inspection"](#).

Is leakage detected?

- YES >> GO TO 3.  
NO >> GO TO 4.

## 3.CHECK COOLING SYSTEM FOR LEAK-II

Check the following for leak.

- Hose
- Radiator
- Water pump

# P1217 ENGINE OVER TEMPERATURE

< DTC/CIRCUIT DIAGNOSIS >

[VQ37VHR FOR MEXICO]

>> Repair or replace malfunctioning part.

## 4. CHECK RADIATOR CAP

Check radiator cap. Refer to [CO-12, "RADIATOR CAP : Inspection"](#).

Is the inspection result normal?

YES >> GO TO 5.

NO >> Replace radiator cap. Refer to [CO-25, "Exploded View"](#).

## 5. CHECK THERMOSTAT

Check thermostat. Refer to [CO-24, "Inspection"](#).

Is the inspection result normal?

YES >> GO TO 6.

NO >> Replace thermostat. Refer to [CO-23, "Exploded View"](#).

## 6. CHECK ENGINE COOLANT TEMPERATURE SENSOR

Refer to [EC-715, "Component Inspection"](#).

Is the inspection result normal?

YES >> GO TO 7.

NO >> Replace engine coolant temperature sensor. Refer to [CO-25, "Exploded View"](#).

## 7. CHECK MAIN 12 CAUSES

If the cause cannot be isolated, check the following.

| Engine | Step | Inspection item  | Equipment  | Standard   | Reference page                                     |
|--------|------|--|--|--|--|
| OFF    | 1    | <ul style="list-style-type: none"> <li>Blocked radiator</li> <li>Blocked condenser</li> <li>Blocked radiator grille</li> <li>Blocked bumper</li> </ul> | <ul style="list-style-type: none"> <li>Visual</li> </ul>                                       | No blocking  | —  |
|        | 2    | <ul style="list-style-type: none"> <li>Coolant mixture</li> </ul>  | <ul style="list-style-type: none"> <li>Coolant tester</li> </ul>                               | <a href="#">MA-17, "FOR NORTH AMERICA : Anti-Freeze Coolant Mixture Ratio"</a> |  |
|        | 3    | <ul style="list-style-type: none"> <li>Coolant level</li> </ul>  | <ul style="list-style-type: none"> <li>Visual</li> </ul>                                       | Coolant up to MAX level in reservoir tank and radiator filler neck             | <a href="#">CO-8, "Inspection"</a>                 |
|        | 4    | <ul style="list-style-type: none"> <li>Radiator cap</li> </ul>   | <ul style="list-style-type: none"> <li>Pressure tester</li> </ul>                              | 107 kPa (1.1 kg/cm <sup>2</sup> , 16 psi) (Limit)                              | <a href="#">CO-12, "RADIATOR CAP : Inspection"</a> |
| ON*2   | 5    | <ul style="list-style-type: none"> <li>Coolant leaks</li> </ul>  | <ul style="list-style-type: none"> <li>Visual</li> </ul>                                       | No leaks   | <a href="#">CO-8, "Inspection"</a>                 |
| ON*2   | 6    | <ul style="list-style-type: none"> <li>Thermostat</li> </ul>   | <ul style="list-style-type: none"> <li>Touch the upper and lower radiator hoses</li> </ul>     | Both hoses should be hot   | <a href="#">CO-24, "Inspection"</a>                |
| ON*1   | 7    | <ul style="list-style-type: none"> <li>Cooling fan</li> </ul>  | <ul style="list-style-type: none"> <li>CONSULT</li> </ul>                                      | Operating  | <a href="#">EC-939, "Component Function Check"</a> |
| OFF    | 8    | <ul style="list-style-type: none"> <li>Combustion gas leak</li> </ul>  | <ul style="list-style-type: none"> <li>Color checker chemical tester 4 Gas analyzer</li> </ul> | Negative   | —  |
| ON*3   | 9    | <ul style="list-style-type: none"> <li>Coolant temperature gauge</li> </ul>  | <ul style="list-style-type: none"> <li>Visual</li> </ul>                                       | Gauge less than 3/4 when driving   | —  |
|        |      | <ul style="list-style-type: none"> <li>Coolant overflow to reservoir tank</li> </ul>   | <ul style="list-style-type: none"> <li>Visual</li> </ul>                                       | No overflow during driving and idling  | <a href="#">CO-8, "Inspection"</a>                 |
| OFF*4  | 10   | <ul style="list-style-type: none"> <li>Coolant return from reservoir tank to radiator</li> </ul>   | <ul style="list-style-type: none"> <li>Visual</li> </ul>                                       | Should be initial level in reservoir tank                                      | <a href="#">CO-8, "Inspection"</a>                 |
| OFF    | 11   | <ul style="list-style-type: none"> <li>Cylinder head</li> </ul>  | <ul style="list-style-type: none"> <li>Straight gauge feeler gauge</li> </ul>                  | 0.1 mm (0.004 in) Maximum distortion (warping)                                 | <a href="#">EM-119, "Inspection"</a>               |
|        | 12   | <ul style="list-style-type: none"> <li>Cylinder block and pistons</li> </ul>   | <ul style="list-style-type: none"> <li>Visual</li> </ul>                                       | No scuffing on cylinder walls or piston  | <a href="#">EM-132, "Inspection"</a>               |

\*1: Turn the ignition switch ON.

\*2: Engine running at 3,000 rpm for 10 minutes.

\*3: Drive at 90 km/h (55 MPH) for 30 minutes and then let idle for 10 minutes.

\*4: After 60 minutes of cool down time.

## P1217 ENGINE OVER TEMPERATURE

< DTC/CIRCUIT DIAGNOSIS >

[VQ37VHR FOR MEXICO]

---

For more information, refer to [CO-6. "Troubleshooting Chart"](#).

>> INSPECTION END



P1225, P1234 TP SENSOR

DTC Logic

INFOID:000000007729981

DTC DETECTION LOGIC

| DTC No. | Trouble diagnosis name                                 | DTC detecting condition                                     | Possible cause   |
|---------|--|---|--|
| P1225   | Closed throttle position learning performance (bank 1) | Closed throttle position learning value is excessively low. | <ul style="list-style-type: none"> <li>Electric throttle control actuator (TP sensor 1 and 2)</li> </ul> |
| P1234   | Closed throttle position learning performance (bank 2) |   |  |

DTC CONFIRMATION PROCEDURE

1. PRECONDITIONING

If DTC Confirmation Procedure has been previously conducted, always perform the following procedure before conducting the next test.

1. Turn ignition switch OFF and wait at least 10 seconds.
2. Turn ignition switch ON.
3. Turn ignition switch OFF and wait at least 10 seconds.

**TESTING CONDITION:**

Before performing the following procedure, confirm that battery voltage is more than 10 V at idle.

>> GO TO 2.

2. PERFORM DTC CONFIRMATION PROCEDURE

1. Turn ignition switch ON.
2. Turn ignition switch OFF and wait at least 10 seconds.
3. Turn ignition switch ON.
4. Check 1st trip DTC.

Is 1st trip DTC detected?

- YES >> Go to [EC-849. "Diagnosis Procedure"](#).
- NO >> INSPECTION END

Diagnosis Procedure

INFOID:000000007729982

1. CHECK ELECTRIC THROTTLE CONTROL ACTUATOR VISUALLY

1. Turn ignition switch OFF.
2. Remove the intake air duct.
3. Check if foreign matter is caught between the throttle valve (1) and the housing.

Is the inspection result normal?

- YES >> GO TO 2.
- NO >> Remove the foreign matter and clean the electric throttle control actuator inside, and then perform throttle valve closed position learning. Refer to [EC-657. "Work Procedure"](#).

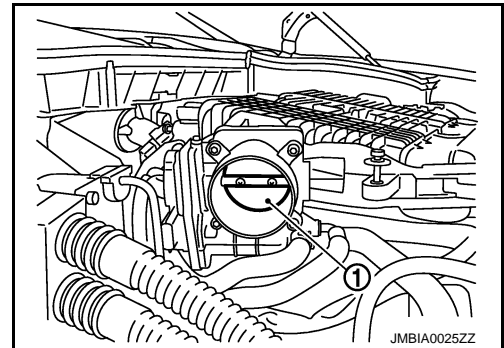

2. REPLACE ELECTRIC THROTTLE CONTROL ACTUATOR

1. Replace malfunctioning electric throttle control actuator.
2. Go to [EC-850. "Special Repair Requirement"](#).

>> INSPECTION END

# P1225, P1234 TP SENSOR

< DTC/CIRCUIT DIAGNOSIS >

[VQ37VHR FOR MEXICO]

---

## Special Repair Requirement

INFOID:000000007729983

### 1. PERFORM THROTTLE VALVE CLOSED POSITION LEARNING

---

Refer to [EC-657, "Work Procedure"](#)

>> GO TO 2.

### 2. PERFORM IDLE AIR VOLUME LEARNING

---

Refer to [EC-658, "Work Procedure"](#)

>> END

P1226, P1235 TP SENSOR

DTC Logic

INFOID:000000007729984

DTC DETECTION LOGIC

| DTC No. | Trouble diagnosis name                                 | DTC detecting condition  | Possible cause   |
|---------|--|--|--|
| P1226   | Closed throttle position learning performance (bank 1) | Closed throttle position learning is not performed successfully, repeatedly. | • Electric throttle control actuator (TP sensor 1 and 2) |
| P1235   | Closed throttle position learning performance (bank 2) |  |  |

DTC CONFIRMATION PROCEDURE

1. PRECONDITIONING

If DTC Confirmation Procedure has been previously conducted, always perform the following procedure before conducting the next test.

1. Turn ignition switch OFF and wait at least 10 seconds.
2. Turn ignition switch ON.
3. Turn ignition switch OFF and wait at least 10 seconds.

**TESTING CONDITION:**

Before performing the following procedure, confirm that battery voltage is more than 10 V at idle.

>> GO TO 2.

2. PERFORM DTC CONFIRMATION PROCEDURE

1. Turn ignition switch ON.
2. Turn ignition switch OFF and wait at least 10 seconds.
3. Turn ignition switch ON.
4. Repeat steps 2 and 3 for 32 times.
5. Check 1st trip DTC.

Is 1st trip DTC detected?

- YES >> Go to [EC-851, "Diagnosis Procedure"](#).
- NO >> INSPECTION END

Diagnosis Procedure

INFOID:000000007729985

1. CHECK ELECTRIC THROTTLE CONTROL ACTUATOR VISUALLY

1. Turn ignition switch OFF.
2. Remove the intake air duct.
3. Check if foreign matter is caught between the throttle valve (1) and the housing.

Is the inspection result normal?

- YES >> GO TO 2.
- NO >> Remove the foreign matter and clean the electric throttle control actuator inside, and then perform throttle valve closed position learning. Refer to [EC-657, "Work Procedure"](#).

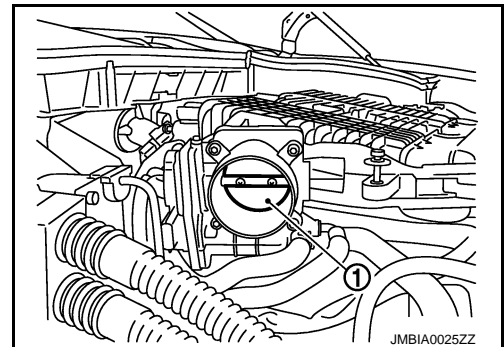

2. REPLACE ELECTRIC THROTTLE CONTROL ACTUATOR

1. Replace malfunctioning electric throttle control actuator.
2. Go to [EC-852, "Special Repair Requirement"](#).

>> INSPECTION END

## P1226, P1235 TP SENSOR

< DTC/CIRCUIT DIAGNOSIS >

[VQ37VHR FOR MEXICO]

---

### Special Repair Requirement

INFOID:000000007729986

#### 1. PERFORM THROTTLE VALVE CLOSED POSITION LEARNING

---

Refer to [EC-657, "Work Procedure"](#)

>> GO TO 2.

#### 2. PERFORM IDLE AIR VOLUME LEARNING

---

Refer to [EC-658, "Work Procedure"](#)

>> END

# P1233, P2101 ELECTRIC THROTTLE CONTROL FUNCTION

< DTC/CIRCUIT DIAGNOSIS >

[VQ37VHR FOR MEXICO]

## P1233, P2101 ELECTRIC THROTTLE CONTROL FUNCTION

### DTC Logic

INFOID:000000007729987

#### DTC DETECTION LOGIC

##### NOTE:

If DTC P1233 or P2101 is displayed with DTC P1238, P1290, P2100 or 2119, first perform the trouble diagnosis for DTC P1238, P2119 or P1290, P2100. Refer to [EC-860, "DTC Logic"](#) or [EC-865, "DTC Logic"](#).

| DTC No. | Trouble diagnosis name                         | DTC detecting condition                                       | Possible cause   |
|---------|--|---|--|
| P1233   | Electric throttle control performance (bank 2) | Electric throttle control function does not operate properly. | <ul style="list-style-type: none"><li>• Harness or connectors (Throttle control motor circuit is open or shorted)</li><li>• Electric throttle control actuator</li></ul> |
| P2101   | Electric throttle control performance (bank 1) |   |  |

#### DTC CONFIRMATION PROCEDURE

##### 1. PRECONDITIONING

If DTC Confirmation Procedure has been previously conducted, always perform the following procedure before conducting the next test.

1. Turn ignition switch OFF and wait at least 10 seconds.
2. Turn ignition switch ON.
3. Turn ignition switch OFF and wait at least 10 seconds.

##### TESTING CONDITION:

Before performing the following procedure, confirm that battery voltage is more than 11 V when engine is running.

>> GO TO 2.

##### 2. PERFORM DTC CONFIRMATION PROCEDURE

1. Turn ignition switch ON and wait at least 2 seconds.
2. Start engine and let it idle for 5 seconds.
3. Check DTC.

Is DTC detected?

- YES >> Go to [EC-853, "Diagnosis Procedure"](#).  
NO >> INSPECTION END

#### Diagnosis Procedure

INFOID:000000007729988

##### 1. CHECK GROUND CONNECTION

1. Turn ignition switch OFF.
2. Check ground connection M95. Refer to Ground Inspection in [GI-47, "Circuit Inspection"](#).

Is the inspection result normal?

- YES >> GO TO 2.  
NO >> Repair or replace ground connection.

##### 2. CHECK THROTTLE CONTROL MOTOR RELAY INPUT SIGNAL CIRCUIT-I

Check the voltage between ECM harness connector terminals as per the following.

# P1233, P2101 ELECTRIC THROTTLE CONTROL FUNCTION

< DTC/CIRCUIT DIAGNOSIS >

[VQ37VHR FOR MEXICO]

| DTC   | ECM       |          |           |                 | Condition       | Voltage (V) |                 |
|-------|-----------|----------|-----------|-----------------|-----------------|-------------|-----------------|
|       | +         |          | -         |                 |                 |             |                 |
|       | Connector | Terminal | Connector | Terminal        |                 |             |                 |
| P1233 | F102      | 52       | M107      | 128             | Ignition switch | OFF         | Approx. 0       |
| P2101 | F101      | 3        |           |                 |                 | ON          | Battery voltage |
|       |           |          | OFF       | Approx. 0       |                 |             |                 |
|       |           |          | ON        | Battery voltage |                 |             |                 |

Is the inspection result normal?

YES >> GO TO 9.

NO >> GO TO 3.

## 3. CHECK THROTTLE CONTROL MOTOR RELAY POWER SUPPLY CIRCUIT

1. Turn ignition switch OFF.
2. Disconnect ECM harness connector.
3. Disconnect IPDM E/R harness connector E7.
4. Check the continuity between IPDM E/R harness connector and ECM harness connector.

| IPDM E/R  |          | ECM       |          | Continuity |
|-----------|----------|-----------|----------|------------|
| Connector | Terminal | Connector | Terminal |            |
| E7        | 71       | F101      | 25       | Existed    |

5. Also check harness for short to ground and short to power.

Is the inspection result normal?

YES >> GO TO 5.

NO >> GO TO 4.

## 4. DETECT MALFUNCTIONING PART

Check the following.

- Harness connectors E20, F40
- Harness for open or short between ECM and IPDM E/R

>> Repair open circuit, short to ground or short to power in harness or connectors.

## 5. CHECK THROTTLE CONTROL MOTOR RELAY INPUT SIGNAL CIRCUIT-II

1. Check the continuity between IPDM E/R harness connector and ECM harness connector.

| DTC   | IPDM E/R  |          | ECM       |          | Continuity |
|-------|-----------|----------|-----------|----------|------------|
|       | Connector | Terminal | Connector | Terminal |            |
| P1233 | E5        | 7        | F102      | 52       | Existed    |
| P2101 |           |          | F101      | 3        |            |

2. Also check harness for short to ground and short to power.

Is the inspection result normal?

YES >> GO TO 7.

NO >> GO TO 6.

## 6. DETECT MALFUNCTIONING PART

Check the following.

- Harness connectors E20, F40
- Harness for open or short between ECM and IPDM E/R

>> Repair open circuit, short to ground or short to power in harness or connectors.

## 7. CHECK FUSE

# P1233, P2101 ELECTRIC THROTTLE CONTROL FUNCTION

[VQ37VHR FOR MEXICO]

## < DTC/CIRCUIT DIAGNOSIS >

1. Disconnect 15 A fuse (No. 50) from IPDM E/R.
2. Check 15 A fuse for blown.

Is the inspection result normal?

- YES >> GO TO 8.  
NO >> Replace 15 A fuse.

## 8.CHECK INTERMITTENT INCIDENT

Refer to [GI-44, "Intermittent Incident"](#).

Is the inspection result normal?

- YES >> Replace IPDM E/R.  
NO >> Repair or replace harness or connectors.

## 9.CHECK THROTTLE CONTROL MOTOR OUTPUT SIGNAL CIRCUIT FOR OPEN OR SHORT

1. Turn ignition switch OFF.
2. Disconnect electric throttle control actuator harness connector.
3. Disconnect ECM harness connector.
4. Check the continuity between electric throttle control actuator harness connector and ECM harness connector.

| DTC   | Electric throttle control actuator |           |          | ECM       |          | Continuity  |
|-------|------------------------------------|-----------|----------|-----------|----------|-------------|
|       | Bank                               | Connector | Terminal | Connector | Terminal |             |
| P1233 | 2                                  | F27       | 5        | F102      | 49       | Existed     |
|       |                                    |           |          |           | 50       | Not existed |
|       |                                    |           | 6        |           | 49       | Not existed |
|       |                                    |           |          |           | 50       | Existed     |
| P2101 | 1                                  | F67       | 1        | F101      | 2        | Existed     |
|       |                                    |           |          |           | 4        | Not existed |
|       |                                    |           | 2        |           | 2        | Not existed |
|       |                                    |           |          |           | 4        | Existed     |

5. Also check harness for short to ground and short to power.

Is the inspection result normal?

- YES >> GO TO 10.  
NO >> Repair or replace.

## 10.CHECK ELECTRIC THROTTLE CONTROL ACTUATOR VISUALLY

1. Remove the intake air duct.
2. Check if foreign matter is caught between the throttle valve (1) and the housing.

Is the inspection result normal?

- YES >> GO TO 11.  
NO >> Remove the foreign matter and clean the electric throttle control actuator inside, and then perform throttle valve closed position learning. Refer to [EC-657, "Work Procedure"](#).

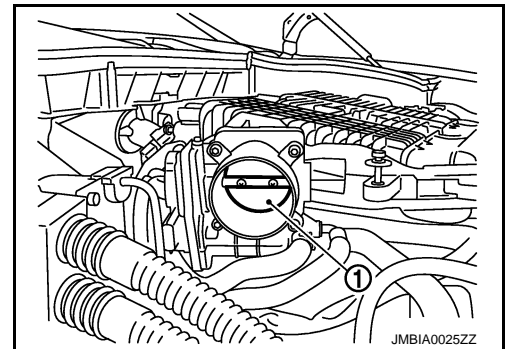

## 11.CHECK THROTTLE CONTROL MOTOR

Refer to [EC-856, "Component Inspection"](#).

Is the inspection result normal?

- YES >> GO TO 12.  
NO >> GO TO 13.

## 12.CHECK INTERMITTENT INCIDENT

# P1233, P2101 ELECTRIC THROTTLE CONTROL FUNCTION

< DTC/CIRCUIT DIAGNOSIS >

[VQ37VHR FOR MEXICO]

Refer to [GI-44, "Intermittent Incident"](#).

Is the inspection result normal?

YES >> GO TO 13.

NO >> Repair or replace harness or connectors.

## 13. REPLACE ELECTRIC THROTTLE CONTROL ACTUATOR

1. Replace malfunction electric throttle control actuator.
2. Go to [EC-856, "Special Repair Requirement"](#).

>> INSPECTION END

## Component Inspection

INFOID:000000007729989

### 1. CHECK THROTTLE CONTROL MOTOR

1. Turn ignition switch OFF.
2. Disconnect electric throttle control actuator harness connector.
3. Check resistance between electric throttle control actuator terminals as per the following.

| Electric throttle control actuator |           | Resistance ( $\Omega$ )         |
|------------------------------------|-----------|---------------------------------|
| Bank                               | Terminals |                                 |
| 1                                  | 1 and 2   | Approx. 1 - 15 [at 25°C (77°F)] |
| 2                                  | 5 and 6   |                                 |

Is the inspection result normal?

YES >> INSPECTION END

NO >> GO TO 2.

### 2. REPLACE ELECTRIC THROTTLE CONTROL ACTUATOR

1. Replace malfunctioning electric throttle control actuator.
2. Go to [EC-856, "Special Repair Requirement"](#).

>> INSPECTION END

## Special Repair Requirement

INFOID:000000007729990

### 1. PERFORM THROTTLE VALVE CLOSED POSITION LEARNING

Refer to [EC-657, "Work Procedure"](#)

>> GO TO 2.

### 2. PERFORM IDLE AIR VOLUME LEARNING

Refer to [EC-658, "Work Procedure"](#)

>> END



# P1236, P2118 THROTTLE CONTROL MOTOR

< DTC/CIRCUIT DIAGNOSIS >

[VQ37VHR FOR MEXICO]

## P1236, P2118 THROTTLE CONTROL MOTOR

### DTC Logic

INFOID:000000007729991

### DTC DETECTION LOGIC

| DTC No. | Trouble diagnosis name                        | DTC detecting condition  | Possible cause  |
|---------|---|--|---|
| P1236   | Throttle control motor (bank 2) circuit short | ECM detects short in both circuits between ECM and throttle control motor. | <ul style="list-style-type: none"> <li>Harness or connectors (Throttle control motor circuit is shorted.)</li> <li>Electric throttle control actuator (Throttle control motor)</li> </ul> |
| P2118   | Throttle control motor (bank 1) circuit short |  |   |

### DTC CONFIRMATION PROCEDURE

#### 1. PRECONDITIONING

If DTC Confirmation Procedure has been previously conducted, always perform the following procedure before conducting the next test.

- Turn ignition switch OFF and wait at least 10 seconds.
- Turn ignition switch ON.
- Turn ignition switch OFF and wait at least 10 seconds.

>> GO TO 2.

#### 2. PERFORM DTC CONFIRMATION PROCEDURE

- Turn ignition switch ON and wait at least 2 seconds.
- Start engine and let it idle for 5 seconds.
- Check DTC.

Is DTC detected?

- YES >> Go to [EC-857, "Diagnosis Procedure"](#).  
 NO >> INSPECTION END

### Diagnosis Procedure

INFOID:000000007729992

#### 1. CHECK GROUND CONNECTION

- Turn ignition switch OFF.
- Check ground connection M95. Refer to Ground Inspection in [GI-47, "Circuit Inspection"](#).

Is the inspection result normal?

- YES >> GO TO 2.  
 NO >> Repair or replace ground connection.

#### 2. CHECK THROTTLE CONTROL MOTOR OUTPUT SIGNAL CIRCUIT FOR OPEN AND SHORT

- Disconnect electric throttle control actuator harness connector.
- Disconnect ECM harness connector.
- Check the continuity between electric throttle control actuator harness connector and ECM harness connector.

| DTC   | Electric throttle control actuator |           |          | ECM       |          | Continuity  |
|-------|------------------------------------|-----------|----------|-----------|----------|-------------|
|       | Bank                               | Connector | Terminal | Connector | Terminal |             |
| P1236 | 2                                  | F27       | 5        | F102      | 49       | Existed     |
|       |                                    |           |          |           | 50       | Not existed |
|       |                                    |           | 6        |           | 49       | Not existed |
|       |                                    |           |          |           | 50       | Existed     |

# P1236, P2118 THROTTLE CONTROL MOTOR

< DTC/CIRCUIT DIAGNOSIS >

[VQ37VHR FOR MEXICO]

| DTC   | Electric throttle control actuator |           |          | ECM       |          | Continuity  |
|-------|------------------------------------|-----------|----------|-----------|----------|-------------|
|       | Bank                               | Connector | Terminal | Connector | Terminal |             |
| P2118 | 1                                  | F67       | 1        | F101      | 2        | Existed     |
|       |                                    |           | 2        |           | 4        | Not existed |
|       |                                    |           |          |           | 2        | Not existed |
|       |                                    |           |          |           | 4        | Existed     |

4. Also check harness for short to ground and short to power.

Is the inspection result normal?

YES >> GO TO 3.

NO >> Repair or replace.

## 3.CHECK THROTTLE CONTROL MOTOR

Refer to [EC-858, "Component Inspection"](#).

Is the inspection result normal?

YES >> GO TO 4.

NO >> GO TO 5.

## 4.CHECK INTERMITTENT INCIDENT

Refer to [GI-44, "Intermittent Incident"](#).

Is the inspection result normal?

YES >> GO TO 5.

NO >> Repair or replace harness or connectors.

## 5.REPLACE ELECTRIC THROTTLE CONTROL ACTUATOR

1. Replace malfunctioning electric throttle control actuator.
2. Go to [EC-858, "Special Repair Requirement"](#).

>> INSPECTION END

## Component Inspection

INFOID:000000007729993

### 1.CHECK THROTTLE CONTROL MOTOR

1. Turn ignition switch OFF.
2. Disconnect electric throttle control actuator harness connector.
3. Check resistance between electric throttle control actuator terminals as per the following.

| Electric throttle control actuator |           | Resistance ( $\Omega$ )         |
|------------------------------------|-----------|---------------------------------|
| Bank                               | Terminals |                                 |
| 1                                  | 1 and 2   | Approx. 1 - 15 [at 25°C (77°F)] |
| 2                                  | 5 and 6   |                                 |

Is the inspection result normal?

YES >> INSPECTION END

NO >> GO TO 2.

### 2.REPLACE ELECTRIC THROTTLE CONTROL ACTUATOR

1. Replace malfunctioning electric throttle control actuator.
2. Go to [EC-858, "Special Repair Requirement"](#).

>> INSPECTION END

## Special Repair Requirement

INFOID:000000007729994

### 1.PERFORM THROTTLE VALVE CLOSED POSITION LEARNING

# P1236, P2118 THROTTLE CONTROL MOTOR

< DTC/CIRCUIT DIAGNOSIS >

[VQ37VHR FOR MEXICO]

Refer to [EC-657. "Work Procedure"](#)

A

>> GO TO 2.

## 2.PERFORM IDLE AIR VOLUME LEARNING

EC

Refer to [EC-658. "Work Procedure"](#)

>> END

C

D

E

F

G

H

I

J

K

L

M

N

O

P

# P1238, P2119 ELECTRIC THROTTLE CONTROL ACTUATOR

< DTC/CIRCUIT DIAGNOSIS >

[VQ37VHR FOR MEXICO]

## P1238, P2119 ELECTRIC THROTTLE CONTROL ACTUATOR

### DTC Logic

INFOID:000000007729995

### DTC DETECTION LOGIC

| DTC No. | Trouble diagnosis name                      | DTC detecting condition |   | Possible cause                       |
|---------|---|-------------------------|---|--------------------------------------|
| P1238   | Electric throttle control actuator (bank 2) | A)                      | Electric throttle control actuator does not function properly due to the return spring malfunction. | • Electric throttle control actuator |
|         |   | B)                      | Throttle valve opening angle in fail-safe mode is not in specified range.                           |                                      |
|         |   | C)                      | ECM detect the throttle valve is stuck open.  |                                      |
| P2119   | Electric throttle control actuator (bank 1) | A)                      | Electric throttle control actuator does not function properly due to the return spring malfunction. |                                      |
|         |   | B)                      | Throttle valve opening angle in fail-safe mode is not in specified range.                           |                                      |
|         |   | C)                      | ECM detect the throttle valve is stuck open.  |                                      |

### DTC CONFIRMATION PROCEDURE

#### 1. PRECONDITIONING

If DTC Confirmation Procedure has been previously conducted, always perform the following procedure before conducting the next test.

1. Turn ignition switch OFF and wait at least 10 seconds.
2. Turn ignition switch ON.
3. Turn ignition switch OFF and wait at least 10 seconds.

>> GO TO 2.

#### 2. PERFORM DTC CONFIRMATION PROCEDURE FOR MALFUNCTION A AND B

1. Turn ignition switch ON and wait at least 1 second.
2. Shift selector lever to D position and wait at least 3 seconds.
3. Shift selector lever to P position.
4. Turn ignition switch OFF and wait at least 10 seconds.
5. Turn ignition switch ON and wait at least 1 second.
6. Shift selector lever to D position and wait at least 3 seconds.
7. Shift selector lever to P position.
8. Turn ignition switch OFF, wait at least 10 seconds, and then turn ON.
9. Check DTC.

Is DTC detected?

YES >> Go to [EC-860. "Diagnosis Procedure"](#).

NO >> GO TO 3.

#### 3. PERFORM DTC CONFIRMATION PROCEDURE FOR MALFUNCTION C

1. Turn ignition switch ON and wait at least 1 second.
2. Shift selector lever to D position and wait at least 3 seconds.
3. Shift selector lever to P position.
4. Start engine and let it idle for 3 seconds.
5. Check DTC.

Is DTC detected?

YES >> Go to [EC-860. "Diagnosis Procedure"](#).

NO >> INSPECTION END

### Diagnosis Procedure

INFOID:000000007729996

#### 1. CHECK ELECTRIC THROTTLE CONTROL ACTUATOR VISUALLY

1. Turn ignition switch OFF.

# P1238, P2119 ELECTRIC THROTTLE CONTROL ACTUATOR

[VQ37VHR FOR MEXICO]

< DTC/CIRCUIT DIAGNOSIS >

2. Remove the intake air duct.
3. Check if foreign matter is caught between the throttle valve (1) and the housing.

Is the inspection result normal?

YES >> GO TO 2.

NO >> Remove the foreign matter and clean the electric throttle control actuator inside, and then perform throttle valve closed position learning. Refer to [EC-657, "Work Procedure"](#).

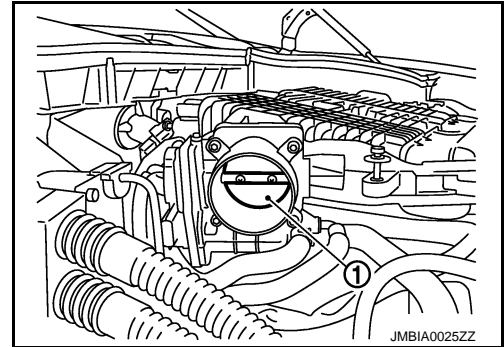

## 2.REPLACE ELECTRIC THROTTLE CONTROL ACTUATOR

1. Replace malfunctioning electric throttle control actuator.
2. Go to [EC-861, "Special Repair Requirement"](#).

>> INSPECTION END

## Special Repair Requirement

INFOID:000000007729997

### 1.PERFORM THROTTLE VALVE CLOSED POSITION LEARNING

Refer to [EC-657, "Work Procedure"](#)

>> GO TO 2.

### 2.PERFORM IDLE AIR VOLUME LEARNING

Refer to [EC-658, "Work Procedure"](#)

>> END

# P1239, P2135 TP SENSOR

< DTC/CIRCUIT DIAGNOSIS >

[VQ37VHR FOR MEXICO]

## P1239, P2135 TP SENSOR

### DTC Logic

INFOID:000000007729998

#### DTC DETECTION LOGIC

##### NOTE:

If DTC P1239 or P2135 is displayed with DTC P0643, first perform the trouble diagnosis for DTC P0643. Refer to [EC-822, "DTC Logic"](#).

| DTC No. | Trouble diagnosis name                                      | DTC detecting condition   | Possible cause  |
|---------|---|---|---|
| P1239   | Throttle position sensor (bank 2) circuit range/performance | Rationally incorrect voltage is sent to ECM compared with the signals from TP sensor 1 and TP sensor 2. | <ul style="list-style-type: none"><li>• Harness or connector (TP sensor 1 or 2 circuit is open or shorted.)</li><li>• Electric throttle control actuator (TP sensor 1 or 2)</li></ul> |
| P2135   | Throttle position sensor (bank 1) circuit range/performance |   |   |

#### DTC CONFIRMATION PROCEDURE

##### 1. PRECONDITIONING

If DTC Confirmation Procedure has been previously conducted, always perform the following procedure before conducting the next test.

1. Turn ignition switch OFF and wait at least 10 seconds.
2. Turn ignition switch ON.
3. Turn ignition switch OFF and wait at least 10 seconds.

##### TESTING CONDITION:

Before performing the following procedure, confirm that battery voltage is more than 10 V at idle.

>> GO TO 2.

##### 2. PERFORM DTC CONFIRMATION PROCEDURE

1. Start engine and let it idle for 1 second.
2. Check DTC.

##### Is DTC detected?

- YES >> Go to [EC-862, "Diagnosis Procedure"](#).  
NO >> INSPECTION END

#### Diagnosis Procedure

INFOID:000000007729999

##### 1. CHECK GROUND CONNECTION

1. Turn ignition switch OFF.
2. Check ground connection M95. Refer to Ground Inspection in [GI-47, "Circuit Inspection"](#).

##### Is the inspection result normal?

- YES >> GO TO 2.  
NO >> Repair or replace ground connection.

##### 2. CHECK THROTTLE POSITION SENSOR POWER SUPPLY CIRCUIT-I

1. Disconnect electric throttle control actuator harness connector.
2. Turn ignition switch ON.
3. Check the voltage between electric throttle control actuator harness connector and ground.

| DTC   | Electric throttle control actuator |           |          | Ground | Voltage (V) |
|-------|------------------------------------|-----------|----------|--------|-------------|
|       | Bank                               | Connector | Terminal |        |             |
| P1239 | 2                                  | F27       | 1        | Ground | Approx. 5   |
| P2135 | 1                                  | F67       | 6        |        |             |

##### Is the inspection result normal?

- YES >> GO TO 3.  
NO >> Repair open circuit, short to ground or short to power in harness or connectors.

# P1239, P2135 TP SENSOR

< DTC/CIRCUIT DIAGNOSIS >

[VQ37VHR FOR MEXICO]

## 3. CHECK THROTTLE POSITION SENSOR GROUND CIRCUIT FOR OPEN AND SHORT

1. Turn ignition switch OFF.
2. Disconnect ECM harness connector.
3. Check the continuity between electric throttle control actuator harness connector and ECM harness connector.

| DTC   | Electric throttle control actuator |           |          | ECM       |          | Continuity |
|-------|------------------------------------|-----------|----------|-----------|----------|------------|
|       | Bank                               | Connector | Terminal | Connector | Terminal |            |
| P1239 | 2                                  | F27       | 4        | F101      | 48       | Existed    |
| P2135 | 1                                  | F67       | 3        |           | 40       |            |

4. Also check harness for short to ground and short to power.

Is the inspection result normal?

YES >> GO TO 4.

NO >> Repair open circuit, short to ground or short to power in harness or connectors.

## 4. CHECK THROTTLE POSITION SENSOR INPUT SIGNAL CIRCUIT FOR OPEN AND SHORT

1. Check the continuity between electric throttle control actuator harness connector and ECM harness connector.

| DTC   | Electric throttle control actuator |           |          | ECM       |          | Continuity |
|-------|------------------------------------|-----------|----------|-----------|----------|------------|
|       | Bank                               | Connector | Terminal | Connector | Terminal |            |
| P1239 | 2                                  | F27       | 2        | F101      | 31       | Existed    |
|       |                                    |           | 3        |           | 35       |            |
| P2135 | 1                                  | F67       | 4        |           | 30       |            |
|       |                                    |           | 5        |           | 34       |            |

2. Also check harness for short to ground and short to power.

Is the inspection result normal?

YES >> GO TO 5.

NO >> Repair open circuit, short to ground or short to power in harness or connectors.

## 5. CHECK THROTTLE POSITION SENSOR

Refer to [EC-863, "Component Inspection"](#).

Is the inspection result normal?

YES >> GO TO 7.

NO >> GO TO 6.

## 6. REPLACE ELECTRIC THROTTLE CONTROL ACTUATOR

1. Replace malfunctioning electric throttle control actuator.
2. [EC-864, "Special Repair Requirement"](#).

>> INSPECTION END

## 7. CHECK INTERMITTENT INCIDENT

Refer to [GI-44, "Intermittent Incident"](#).

>> INSPECTION END

## Component Inspection

INFOID:000000007730000

## 1. CHECK THROTTLE POSITION SENSOR

1. Turn ignition switch OFF.
2. Reconnect all harness connectors disconnected.
3. Perform [EC-657, "Work Procedure"](#).

# P1239, P2135 TP SENSOR

[VQ37VHR FOR MEXICO]

< DTC/CIRCUIT DIAGNOSIS >

4. Turn ignition switch ON.
5. Set selector lever to D position.
6. Check the voltage between ECM harness connector terminals as per the following.

| ECM       |                           |          | Condition         | Voltage (V)     |                |
|-----------|---------------------------|----------|-------------------|-----------------|----------------|
| Connector | +                         | -        |                   |                 |                |
|           | Terminal                  | Terminal |                   |                 |                |
| F101      | 30 [TP sensor 1 (bank 1)] | 40       | Accelerator pedal | Fully released  | More than 0.36 |
|           |                           |          |                   | Fully depressed | Less than 4.75 |
|           | 31 [TP sensor 1 (bank 2)] | 48       |                   | Fully released  | More than 0.36 |
|           |                           |          |                   | Fully depressed | Less than 4.75 |
|           | 34 [TP sensor 2 (bank 1)] | 40       |                   | Fully released  | Less than 4.75 |
|           |                           |          |                   | Fully depressed | More than 0.36 |
|           | 35 [TP sensor 2 (bank 2)] | 48       |                   | Fully released  | Less than 4.75 |
|           |                           |          |                   | Fully depressed | More than 0.36 |

Is the inspection result normal?

YES >> INSPECTION END

NO >> GO TO 2.

## 2. REPLACE ELECTRIC THROTTLE CONTROL ACTUATOR

1. Replace malfunctioning electric throttle control actuator.
2. Go to [EC-864, "Special Repair Requirement"](#).

>> INSPECTION END

## Special Repair Requirement

INFOID:000000007730001

## 1. PERFORM THROTTLE VALVE CLOSED POSITION LEARNING

Refer to [EC-657, "Work Procedure"](#)

>> GO TO 2.

## 2. PERFORM IDLE AIR VOLUME LEARNING

Refer to [EC-658, "Work Procedure"](#)

>> END



# P1290, P2100, P2103 THROTTLE CONTROL MOTOR RELAY

< DTC/CIRCUIT DIAGNOSIS >

[VQ37VHR FOR MEXICO]

## P1290, P2100, P2103 THROTTLE CONTROL MOTOR RELAY

### DTC Logic

INFOID:000000007730002

### DTC DETECTION LOGIC

| DTC No. | Trouble diagnosis name                             | DTC detecting condition  | Possible cause  |
|---------|--|--|---|
| P1290   | Throttle control motor relay circuit open (bank 2) | ECM detects a voltage of power source for throttle control motor is excessively low. | <ul style="list-style-type: none"> <li>• Harness or connectors (Throttle control motor relay circuit is open)</li> <li>• Throttle control motor relay</li> </ul>    |
| P2100   | Throttle control motor relay circuit open (bank 1) |  |   |
| P2103   | Throttle control motor relay circuit short         | ECM detect the throttle control motor relay is stuck ON.                             | <ul style="list-style-type: none"> <li>• Harness or connectors (Throttle control motor relay circuit is shorted)</li> <li>• Throttle control motor relay</li> </ul> |

### DTC CONFIRMATION PROCEDURE

#### 1. PRECONDITIONING

If DTC Confirmation Procedure has been previously conducted, always perform the following procedure before conducting the next test.

1. Turn ignition switch OFF and wait at least 10 seconds.
2. Turn ignition switch ON.
3. Turn ignition switch OFF and wait at least 10 seconds.

#### TESTING CONDITION:

**Before performing the following procedure, confirm that battery voltage is more than 8 V.**

Which DTC is detected?

P1290, P2100 >> GO TO 2.

P2103 >> GO TO 3.

#### 2. PERFORM DTC CONFIRMATION PROCEDURE FOR DTC P1290 AND P2100

1. Turn ignition switch ON and wait at least 2 seconds.
2. Start engine and let it idle for 5 seconds.
3. Check DTC.

Is DTC detected?

YES >> Go to [EC-865, "Diagnosis Procedure"](#).

NO >> INSPECTION END

#### 3. PERFORM DTC CONFIRMATION PROCEDURE FOR DTC P2103

1. Turn ignition switch ON and wait at least 1 second.
2. Check DTC.

Is DTC detected?

YES >> Go to [EC-865, "Diagnosis Procedure"](#).

NO >> INSPECTION END

### Diagnosis Procedure

INFOID:000000007730003

#### 1. CHECK THROTTLE CONTROL MOTOR RELAY POWER SUPPLY CIRCUIT

1. Turn ignition switch OFF.
2. Disconnect ECM harness connector.
3. Disconnect IPDM E/R harness connector E7.
4. Check the continuity between IPDM E/R harness connector and ECM harness connector.

| IPDM E/R  |          | ECM       |          | Continuity |
|-----------|----------|-----------|----------|------------|
| Connector | Terminal | Connector | Terminal |            |
| E7        | 71       | F101      | 25       | Existed    |

5. Also check harness for short to ground and short to power.

# P1290, P2100, P2103 THROTTLE CONTROL MOTOR RELAY

[VQ37VHR FOR MEXICO]

< DTC/CIRCUIT DIAGNOSIS >

Is the inspection result normal?

YES >> GO TO 3.

NO >> GO TO 2.

## 2.DETECT MALFUNCTIONING PART

Check the following.

- Harness connectors E20, F40
- Harness for open or short between ECM and IPDM E/R

>> Repair open circuit, short to ground or short to power in harness or connectors.

## 3.CHECK THROTTLE CONTROL MOTOR RELAY INPUT SIGNAL CIRCUIT

1. Check the continuity between IPDM E/R sensor harness connector and ECM harness connector.

| DTC   | IPDM E/R  |          | ECM       |          | Continuity |
|-------|-----------|----------|-----------|----------|------------|
|       | Connector | Terminal | Connector | Terminal |            |
| P1290 | E5        | 7        | F102      | 52       | Existed    |
| P2100 |           |          | F101      | 3        |            |
| P2103 |           |          | F101      | 3        |            |
|       |           |          | F102      | 52       |            |

2. Also check harness for short to ground and short to power.

Is the inspection result normal?

YES >> GO TO 5.

NO >> GO TO 4.

## 4.DETECT MALFUNCTIONING PART

Check the following.

- Harness connectors E20, F40
- Harness for open or short between ECM and IPDM E/R

>> Repair open circuit, short to ground or short to power in harness or connectors.

## 5.CHECK FUSE

1. Disconnect 15 A fuse (No. 50) from IPDM E/R.

2. Check 15 A fuse for blown.

Is the inspection result normal?

YES >> GO TO 6.

NO >> Replace 15A fuse.

## 6.CHECK INTERMITTENT INCIDENT

Refer to [GI-44, "Intermittent Incident"](#).

Is the inspection result normal?

YES >> Replace IPDM E/R. Refer to [PCS-33, "Exploded View"](#).

NO >> Repair or replace harness or connectors.

# P1550 BATTERY CURRENT SENSOR

< DTC/CIRCUIT DIAGNOSIS >

[VQ37VHR FOR MEXICO]

## P1550 BATTERY CURRENT SENSOR

### DTC Logic

INFOID:000000007730007

### DTC DETECTION LOGIC

| DTC No. | Trouble diagnosis name                           | DTC detecting condition  | Possible cause   |
|---------|--|--|--|
| P1550   | Battery current sensor circuit range/performance | The output voltage of the battery current sensor remains within the specified range while engine is running. | <ul style="list-style-type: none"> <li>• Harness or connectors<br/>(Battery current sensor circuit is open or shorted.)<br/>[CKP sensor (POS) circuit is open or shorted.]<br/>[CMP sensor (PHASE) (bank 2) circuit is open or shorted.]<br/>(APP sensor 2 circuit is shorted.)<br/>(EVAP control system pressure sensor circuit is shorted.)<br/>(Refrigerant pressure sensor circuit is shorted.)</li> <li>• Battery current sensor</li> <li>• Crankshaft position sensor (POS)</li> <li>• Camshaft position sensor (PHASE) (bank 2)</li> <li>• Accelerator pedal position sensor</li> <li>• EVAP control system pressure sensor</li> <li>• Refrigerant pressure sensor</li> </ul> |

### DTC CONFIRMATION PROCEDURE

#### 1. PRECONDITIONING

If DTC Confirmation Procedure has been previously conducted, always perform the following procedure before conducting the next test.

1. Turn ignition switch OFF and wait at least 10 seconds.
2. Turn ignition switch ON.
3. Turn ignition switch OFF and wait at least 10 seconds.

#### TESTING CONDITION:

**Before performing the following procedure, confirm that battery voltage is more than 8 V at idle.**

>> GO TO 2.

#### 2. PERFORM DTC CONFIRMATION PROCEDURE

1. Start engine and wait at least 10 seconds.
2. Check 1st trip DTC.

Is 1st trip DTC detected?

YES >> Go to [EC-867, "Diagnosis Procedure"](#).

NO >> INSPECTION END

### Diagnosis Procedure

INFOID:000000007730008

#### 1. CHECK GROUND CONNECTION

1. Turn ignition switch OFF.
2. Check ground connection M95. Refer to Ground Inspection in [GI-47, "Circuit Inspection"](#).

Is the inspection result normal?

YES >> GO TO 2.

NO >> Repair or replace ground connection.

#### 2. CHECK BATTERY CURRENT SENSOR POWER SUPPLY CIRCUIT-I

1. Disconnect battery current sensor harness connector.
2. Turn ignition switch ON.
3. Check the voltage between battery current sensor harness connector and ground.

| Battery current sensor |          | Ground | Voltage (V) |
|------------------------|----------|--------|-------------|
| Connector              | Terminal |        |             |
| E21                    | 1        | Ground | Approx. 5   |

# P1550 BATTERY CURRENT SENSOR

< DTC/CIRCUIT DIAGNOSIS >

[VQ37VHR FOR MEXICO]

Is the inspection result normal?

- YES >> GO TO 9.
- NO >> GO TO 3.

## 3. CHECK BATTERY CURRENT SENSOR POWER SUPPLY CIRCUIT-II

1. Turn ignition switch OFF.
2. Disconnect ECM harness connector.
3. Check the continuity between battery current sensor harness connector and ECM harness connector.

| Battery current sensor |          | ECM       |          | Continuity |
|------------------------|----------|-----------|----------|------------|
| Connector              | Terminal | Connector | Terminal |            |
| E21                    | 1        | F102      | 64       | Existed    |

Is the inspection result normal?

- YES >> GO TO 5.
- NO >> GO TO 4.

## 4. DETECT MALFUNCTIONING PART

Check the following.

- Harness connectors F40, E20
- Harness for open between battery current sensor and ECM

>> Repair open circuit.

## 5. CHECK SENSOR POWER SUPPLY CIRCUIT

Check harness for short to power and short to ground, between the following terminals.

| ECM       |          | Sensor                              |  |                                    |
|-----------|----------|-------------------------------------|--|------------------------------------|
| Connector | Terminal | Name                                | Connector                              | Terminal                           |
| F101      | 46       | CKP sensor (POS)                    | F2                                     | 1                                  |
| F102      | 64       | CMP sensor (PHASE) (bank 2)         | F18                                    | 1                                  |
|           |          | Battery current sensor              | E21                                    |                                    |
| M107      | 103      | APP sensor                          | M153 <sup>*1</sup><br>M9 <sup>*2</sup> | 3 <sup>*1</sup><br>6 <sup>*2</sup> |
|           | 107      | EVAP control system pressure sensor | B73                                    | 3                                  |
|           |          | Refrigerant pressure sensor         | E77                                    | 3                                  |

\*1: With ICC

\*2: Without ICC

Is the inspection result normal?

- YES >> GO TO 6.
- NO >> Repair short to ground or short to power in harness or connectors.

## 6. CHECK COMPONENTS

Check the following.

- Crankshaft position sensor (POS) (Refer to [EC-781, "Component Inspection".](#))
- Camshaft position sensor (PHASE) (bank 2) (Refer to [EC-786, "Component Inspection".](#))
- Refrigerant pressure sensor (Refer to [EC-967, "Diagnosis Procedure".](#))

Is the inspection result normal?

- YES >> GO TO 7.
- NO >> Replace malfunctioning component.

## 7. CHECK APP SENSOR

Refer to [EC-870, "Component Inspection".](#)

Is the inspection result normal?

# P1550 BATTERY CURRENT SENSOR

< DTC/CIRCUIT DIAGNOSIS >

[VQ37VHR FOR MEXICO]

- YES >> GO TO 14.  
NO >> GO TO 8.

## 8. REPLACE ACCELERATOR PEDAL ASSEMBLY

1. Replace accelerator pedal assembly.
2. Go to [EC-920, "Special Repair Requirement"](#).

>> INSPECTION END

## 9. CHECK BATTERY CURRENT SENSOR GROUND CIRCUIT FOR OPEN AND SHORT

1. Turn ignition switch OFF.
2. Disconnect ECM harness connector.
3. Check the continuity between battery current sensor harness connector and ECM harness connector.

| Battery current sensor |          | ECM       |          | Continuity |
|------------------------|----------|-----------|----------|------------|
| Connector              | Terminal | Connector | Terminal |            |
| E21                    | 3        | F102      | 95       | Existed    |

4. Also check harness for short to ground and short to power.

Is the inspection result normal?

- YES >> GO TO 11.  
NO >> GO TO 10.

## 10. DETECT MALFUNCTIONING PART

Check the following.

- Harness connectors E20, F40
- Harness for open or short between battery current sensor and ECM

>> Repair open circuit, short to ground or short to power in harness or connectors.

## 11. CHECK BATTERY CURRENT SENSOR INPUT SIGNAL CIRCUIT FOR OPEN AND SHORT

1. Check the continuity between battery current sensor harness connector and ECM harness connector.

| Battery current sensor |          | ECM       |          | Continuity |
|------------------------|----------|-----------|----------|------------|
| Connector              | Terminal | Connector | Terminal |            |
| E21                    | 4        | F102      | 91       | Existed    |

2. Also check harness for short to ground and short to power.

Is the inspection result normal?

- YES >> GO TO 13.  
NO >> GO TO 12.

## 12. DETECT MALFUNCTIONING PART

Check the following.

- Harness connectors E20, F40
- Harness for open or short between battery current sensor and ECM

>> Repair open circuit, short to ground or short to power in harness or connectors.

## 13. CHECK BATTERY CURRENT SENSOR

Refer to [EC-870, "Component Inspection"](#).

Is the inspection result normal?

- YES >> GO TO 14.  
NO >> Replace battery negative cable assembly.

## 14. CHECK INTERMITTENT INCIDENT

Refer to [GI-44, "Intermittent Incident"](#).

# P1550 BATTERY CURRENT SENSOR

< DTC/CIRCUIT DIAGNOSIS >

[VQ37VHR FOR MEXICO]

>> INSPECTION END

## Component Inspection

INFOID:000000007730009

### 1. CHECK BATTERY CURRENT SENSOR

1. Turn ignition switch OFF.
2. Reconnect harness connectors disconnected.
3. Disconnect battery negative cable (1).

←: To body ground

4. Install jumper cable (A) between battery negative terminal and body ground.
5. Turn ignition switch ON.
6. Check the voltage between ECM harness connector terminals as per the following.

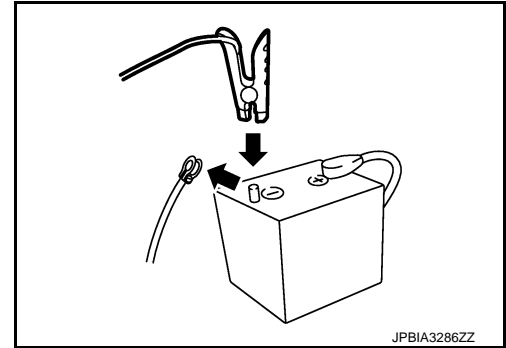

| Connector | ECM                                   |          | Voltage (V) |
|-----------|---------------------------------------|----------|-------------|
|           | +                                     | -        |             |
|           | Terminal                              | Terminal |             |
| F102      | 91<br>(Battery current sensor signal) | 95       | Approx. 2.5 |

Before measuring the terminal voltage, confirm that the battery is fully charged. Refer to [PG-135. "How to Handle Battery"](#).

Is the inspection result normal?

- YES >> INSPECTION END  
NO >> Replace battery negative cable assembly.

# P1551, P1552 BATTERY CURRENT SENSOR

< DTC/CIRCUIT DIAGNOSIS >

[VQ37VHR FOR MEXICO]

## P1551, P1552 BATTERY CURRENT SENSOR

### DTC Logic

INFOID:000000007730010

### DTC DETECTION LOGIC

| DTC No. | Trouble diagnosis name                    | DTC detecting condition                                     | Possible cause   |
|---------|---|---|--|
| P1551   | Battery current sensor circuit low input  | An excessively low voltage from the sensor is sent to ECM.  | <ul style="list-style-type: none"><li>• Harness or connectors (Battery current sensor circuit is open or shorted.) [CKP sensor (POS) circuit is open or shorted.] [CMP sensor (PHASE) (bank 2) circuit is open or shorted.] (APP sensor 2 circuit is shorted.) (EVAP control system pressure sensor circuit is shorted.) (Refrigerant pressure sensor circuit is shorted.)</li><li>• Battery current sensor</li><li>• Crankshaft position sensor (POS)</li><li>• Camshaft position sensor (PHASE) (bank 2)</li><li>• Accelerator pedal position sensor</li><li>• EVAP control system pressure sensor</li><li>• Refrigerant pressure sensor</li></ul> |
| P1552   | Battery current sensor circuit high input | An excessively high voltage from the sensor is sent to ECM. |  |

### DTC CONFIRMATION PROCEDURE

#### 1. PRECONDITIONING

If DTC Confirmation Procedure has been previously conducted, always perform the following procedure before conducting the next test.

1. Turn ignition switch OFF and wait at least 10 seconds.
2. Turn ignition switch ON.
3. Turn ignition switch OFF and wait at least 10 seconds.

#### TESTING CONDITION:

**Before performing the following procedure, confirm that battery voltage is more than 8 V with ignition switch ON**

>> GO TO 2.

#### 2. PERFORM DTC CONFIRMATION PROCEDURE

1. Turn ignition switch ON and wait at least 10 seconds.
2. Check 1st trip DTC.

Is 1st trip DTC detected?

- YES >> Go to [EC-871, "Diagnosis Procedure"](#).  
NO >> INSPECTION END

### Diagnosis Procedure

INFOID:000000007730011

#### 1. CHECK GROUND CONNECTION

1. Turn ignition switch OFF.
2. Check ground connection M95. Refer to Ground Inspection in [GI-47, "Circuit Inspection"](#).

Is the inspection result normal?

- YES >> GO TO 2.  
NO >> Repair or replace ground connection.

#### 2. CHECK BATTERY CURRENT SENSOR POWER SUPPLY CIRCUIT-I

1. Disconnect battery current sensor harness connector.
2. Turn ignition switch ON.
3. Check the voltage between battery current sensor harness connector and ground.

# P1551, P1552 BATTERY CURRENT SENSOR

< DTC/CIRCUIT DIAGNOSIS >

[VQ37VHR FOR MEXICO]

| Battery current sensor |          | Ground | Voltage (V) |
|------------------------|----------|--------|-------------|
| Connector              | Terminal |        |             |
| E21                    | 1        | Ground | Approx. 5   |

Is the inspection result normal?

YES >> GO TO 9.

NO >> GO TO 3.

## 3.CHECK BATTERY CURRENT SENSOR POWER SUPPLY CIRCUIT-II

1. Turn ignition switch OFF.
2. Disconnect ECM harness connector.
3. Check the continuity between battery current sensor harness connector and ECM harness connector.

| Battery current sensor |          | ECM       |          | Continuity |
|------------------------|----------|-----------|----------|------------|
| Connector              | Terminal | Connector | Terminal |            |
| E21                    | 1        | F102      | 64       | Existed    |

Is the inspection result normal?

YES >> GO TO 5.

NO >> GO TO 4.

## 4.DETECT MALFUNCTIONING PART

Check the following.

- Harness connectors F40, E20
- Harness for open between battery current sensor and ECM

>> Repair open circuit.

## 5.CHECK SENSOR POWER SUPPLY CIRCUIT

Check harness for short to power and short to ground, between the following terminals.

| ECM       |          | Sensor                              |           |          |
|-----------|----------|-------------------------------------|-----------|----------|
| Connector | Terminal | Name                                | Connector | Terminal |
| F101      | 46       | CKP sensor (POS)                    | F2        | 1        |
| F102      | 64       | CMP sensor (PHASE) (bank 2)         | F18       | 1        |
|           |          | Battery current sensor              | E21       |          |
| M107      | 103      | APP sensor                          | M153*1    | 3*1      |
|           |          |                                     | M9*2      | 6*2      |
|           | 107      | EVAP control system pressure sensor | B73       | 3        |
|           |          | Refrigerant pressure sensor         | E77       | 3        |

\*1: With ICC

\*2: Without ICC

Is the inspection result normal?

YES >> GO TO 6.

NO >> Repair short to ground or short to power in harness or connectors.

## 6.CHECK COMPONENTS

Check the following.

- Crankshaft position sensor (POS) (Refer to [EC-781, "Component Inspection".](#))
- Camshaft position sensor (PHASE) (bank 2) (Refer to [EC-786, "Component Inspection".](#))
- Refrigerant pressure sensor (Refer to [EC-967, "Diagnosis Procedure".](#))

Is the inspection result normal?

YES >> GO TO 7.



# P1551, P1552 BATTERY CURRENT SENSOR

< DTC/CIRCUIT DIAGNOSIS >

[VQ37VHR FOR MEXICO]

NO >> Replace malfunctioning component.

## 7. CHECK APP SENSOR

Refer to [EC-882, "Component Inspection"](#).

Is the inspection result normal?

YES >> GO TO 14.

NO >> GO TO 8.

## 8. REPLACE ACCELERATOR PEDAL ASSEMBLY

1. Replace accelerator pedal assembly.
2. Go to [EC-920, "Special Repair Requirement"](#).

>> INSPECTION END

## 9. CHECK BATTERY CURRENT SENSOR GROUND CIRCUIT FOR OPEN AND SHORT

1. Turn ignition switch OFF.
2. Disconnect ECM harness connector.
3. Check the continuity between battery current sensor harness connector and ECM harness connector.

| Battery current sensor |          | ECM       |          | Continuity |
|------------------------|----------|-----------|----------|------------|
| Connector              | Terminal | Connector | Terminal |            |
| E21                    | 3        | F102      | 95       | Existed    |

4. Also check harness for short to ground and short to power.

Is the inspection result normal?

YES >> GO TO 11.

NO >> GO TO 10.

## 10. DETECT MALFUNCTIONING PART

Check the following.

- Harness connectors E20, F40
- Harness for open or short between battery current sensor and ECM

>> Repair open circuit, short to ground or short to power in harness or connectors.

## 11. CHECK BATTERY CURRENT SENSOR INPUT SIGNAL CIRCUIT FOR OPEN AND SHORT

1. Check the continuity between battery current sensor harness connector and ECM harness connector.

| Battery current sensor |          | ECM       |          | Continuity |
|------------------------|----------|-----------|----------|------------|
| Connector              | Terminal | Connector | Terminal |            |
| E21                    | 4        | F102      | 91       | Existed    |

2. Also check harness for short to ground and short to power.

Is the inspection result normal?

YES >> GO TO 13.

NO >> GO TO 12.

## 12. DETECT MALFUNCTIONING PART

Check the following.

- Harness connectors E20, F40
- Harness for open or short between battery current sensor and ECM

>> Repair open circuit, short to ground or short to power in harness or connectors.

## 13. CHECK BATTERY CURRENT SENSOR

Refer to [EC-882, "Component Inspection"](#).

Is the inspection result normal?

# P1551, P1552 BATTERY CURRENT SENSOR

< DTC/CIRCUIT DIAGNOSIS >

[VQ37VHR FOR MEXICO]

- YES >> GO TO 14.  
NO >> Replace battery negative cable assembly.

## 14.CHECK INTERMITTENT INCIDENT

Refer to [GI-44. "Intermittent Incident"](#).

>> INSPECTION END

## Component Inspection

INFOID:000000007730012

### 1.CHECK BATTERY CURRENT SENSOR

1. Turn ignition switch OFF.
2. Reconnect harness connectors disconnected.
3. Disconnect battery negative cable (1).

←: To body ground

4. Install jumper cable (A) between battery negative terminal and body ground.
5. Turn ignition switch ON.
6. Check the voltage between ECM harness connector terminals as per the following.

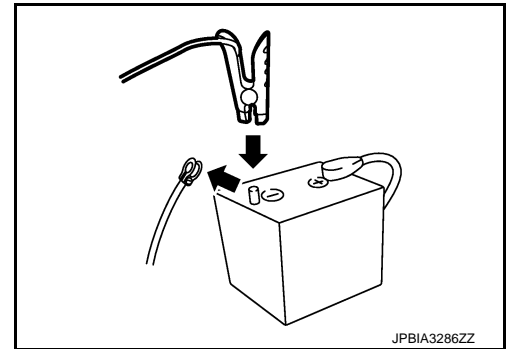

| Connector | ECM                                   |          | Voltage (V) |
|-----------|---------------------------------------|----------|-------------|
|           | +                                     | -        |             |
|           | Terminal                              | Terminal |             |
| F102      | 91<br>(Battery current sensor signal) | 95       | Approx. 2.5 |

Before measuring the terminal voltage, confirm that the battery is fully charged. Refer to [PG-135. "How to Handle Battery"](#).

Is the inspection result normal?

- YES >> INSPECTION END  
NO >> Replace battery negative cable assembly.

# P1553 BATTERY CURRENT SENSOR

< DTC/CIRCUIT DIAGNOSIS >

[VQ37VHR FOR MEXICO]

## P1553 BATTERY CURRENT SENSOR

### DTC Logic

INFOID:000000007730013

### DTC DETECTION LOGIC

| DTC No. | Trouble diagnosis name             | DTC detecting condition  | Possible cause   |
|---------|------------------------------------|--|--|
| P1553   | Battery current sensor performance | The signal voltage transmitted from the sensor to ECM is higher than the amount of the maximum power generation. | <ul style="list-style-type: none"><li>• Harness or connectors<br/>(Battery current sensor circuit is open or shorted.)<br/>[CKP sensor (POS) circuit is open or shorted.]<br/>[CMP sensor (PHASE) (bank 2) circuit is open or shorted.]<br/>(APP sensor 2 circuit is shorted.)<br/>(EVAP control system pressure sensor circuit is shorted.)<br/>(Refrigerant pressure sensor circuit is shorted.)</li><li>• Battery current sensor</li><li>• Crankshaft position sensor (POS)</li><li>• Camshaft position sensor (PHASE) (bank 2)</li><li>• Accelerator pedal position sensor</li><li>• EVAP control system pressure sensor</li><li>• Refrigerant pressure sensor</li></ul> |

### DTC CONFIRMATION PROCEDURE

#### 1. PRECONDITIONING

If DTC Confirmation Procedure has been previously conducted, always perform the following procedure before conducting the next test.

1. Turn ignition switch OFF and wait at least 10 seconds.
2. Turn ignition switch ON.
3. Turn ignition switch OFF and wait at least 10 seconds.

#### TESTING CONDITION:

**Before performing the following procedure, confirm that battery voltage is more than 8 V at idle.**

>> GO TO 2.

#### 2. PERFORM DTC CONFIRMATION PROCEDURE

1. Start engine and wait at least 10 seconds.
2. Check 1st trip DTC.

Is 1st trip DTC detected?

YES >> Go to [EC-875, "Diagnosis Procedure"](#).

NO >> INSPECTION END

### Diagnosis Procedure

INFOID:000000007730014

#### 1. CHECK GROUND CONNECTION

1. Turn ignition switch OFF.
2. Check ground connection M95. Refer to Ground Inspection in [GI-47, "Circuit Inspection"](#).

Is the inspection result normal?

YES >> GO TO 2.

NO >> Repair or replace ground connection.

#### 2. CHECK BATTERY CURRENT SENSOR POWER SUPPLY CIRCUIT-I

1. Disconnect battery current sensor harness connector.
2. Turn ignition switch ON.
3. Check the voltage between battery current sensor harness connector and ground.

| Battery current sensor |          | Ground | Voltage (V) |
|------------------------|----------|--------|-------------|
| Connector              | Terminal |        |             |
| E21                    | 1        | Ground | Approx. 5   |

# P1553 BATTERY CURRENT SENSOR

< DTC/CIRCUIT DIAGNOSIS >

[VQ37VHR FOR MEXICO]

Is the inspection result normal?

- YES >> GO TO 9.
- NO >> GO TO 3.

## 3.CHECK BATTERY CURRENT SENSOR POWER SUPPLY CIRCUIT-II

1. Turn ignition switch OFF.
2. Disconnect ECM harness connector.
3. Check the continuity between battery current sensor harness connector and ECM harness connector.

| Battery current sensor |          | ECM       |          | Continuity |
|------------------------|----------|-----------|----------|------------|
| Connector              | Terminal | Connector | Terminal |            |
| E21                    | 1        | F102      | 64       | Existed    |

Is the inspection result normal?

- YES >> GO TO 5.
- NO >> GO TO 4.

## 4.DETECT MALFUNCTIONING PART

Check the following.

- Harness connectors F40, E20
- Harness for open between battery current sensor and ECM

>> Repair open circuit.

## 5.CHECK SENSOR POWER SUPPLY CIRCUIT

Check harness for short to power and short to ground, between the following terminals.

| ECM       |          | Sensor                              |                |            |
|-----------|----------|-------------------------------------|----------------|------------|
| Connector | Terminal | Name                                | Connector      | Terminal   |
| F101      | 46       | CKP sensor (POS)                    | F2             | 1          |
| F102      | 64       | CMP sensor (PHASE) (bank 2)         | F18            | 1          |
|           |          | Battery current sensor              | E21            |            |
| M107      | 103      | APP sensor                          | M153*1<br>M9*2 | 3*1<br>6*2 |
|           | 107      | EVAP control system pressure sensor | B73            | 3          |
|           |          | Refrigerant pressure sensor         | E77            | 3          |

\*1: With ICC

\*2: Without ICC

Is the inspection result normal?

- YES >> GO TO 6.
- NO >> Repair short to ground or short to power in harness or connectors.

## 6.CHECK COMPONENTS

Check the following.

- Crankshaft position sensor (POS) (Refer to [EC-781, "Component Inspection".](#))
- Camshaft position sensor (PHASE) (bank 2) (Refer to [EC-786, "Component Inspection".](#))
- Refrigerant pressure sensor (Refer to [EC-967, "Diagnosis Procedure".](#))

Is the inspection result normal?

- YES >> GO TO 7.
- NO >> Replace malfunctioning component.

## 7.CHECK APP SENSOR

Refer to [EC-882, "Component Inspection".](#)

Is the inspection result normal?

# P1553 BATTERY CURRENT SENSOR

< DTC/CIRCUIT DIAGNOSIS >

[VQ37VHR FOR MEXICO]

- YES >> GO TO 14.  
NO >> GO TO 8.

## 8. REPLACE ACCELERATOR PEDAL ASSEMBLY

1. Replace accelerator pedal assembly.
2. Go to [EC-920, "Special Repair Requirement"](#).

>> INSPECTION END

## 9. CHECK BATTERY CURRENT SENSOR GROUND CIRCUIT FOR OPEN AND SHORT

1. Turn ignition switch OFF.
2. Disconnect ECM harness connector.
3. Check the continuity between battery current sensor harness connector and ECM harness connector.

| Battery current sensor |          | ECM       |          | Continuity |
|------------------------|----------|-----------|----------|------------|
| Connector              | Terminal | Connector | Terminal |            |
| E21                    | 3        | F102      | 95       | Existed    |

4. Also check harness for short to ground and short to power.

Is the inspection result normal?

- YES >> GO TO 11.  
NO >> GO TO 10.

## 10. DETECT MALFUNCTIONING PART

Check the following.

- Harness connectors E20, F40
- Harness for open or short between battery current sensor and ECM

>> Repair open circuit, short to ground or short to power in harness or connectors.

## 11. CHECK BATTERY CURRENT SENSOR INPUT SIGNAL CIRCUIT FOR OPEN AND SHORT

1. Check the continuity between battery current sensor harness connector and ECM harness connector.

| Battery current sensor |          | ECM       |          | Continuity |
|------------------------|----------|-----------|----------|------------|
| Connector              | Terminal | Connector | Terminal |            |
| E21                    | 4        | F102      | 91       | Existed    |

2. Also check harness for short to ground and short to power.

Is the inspection result normal?

- YES >> GO TO 13.  
NO >> GO TO 12.

## 12. DETECT MALFUNCTIONING PART

Check the following.

- Harness connectors E20, F40
- Harness for open or short between battery current sensor and ECM

>> Repair open circuit, short to ground or short to power in harness or connectors.

## 13. CHECK BATTERY CURRENT SENSOR

Refer to [EC-882, "Component Inspection"](#).

Is the inspection result normal?

- YES >> GO TO 14.  
NO >> Replace battery negative cable assembly.

## 14. CHECK INTERMITTENT INCIDENT

Refer to [GI-44, "Intermittent Incident"](#).

# P1553 BATTERY CURRENT SENSOR

< DTC/CIRCUIT DIAGNOSIS >

[VQ37VHR FOR MEXICO]

>> INSPECTION END

## Component Inspection

INFOID:000000007730015

### 1. CHECK BATTERY CURRENT SENSOR

1. Turn ignition switch OFF.
2. Reconnect harness connectors disconnected.
3. Disconnect battery negative cable (1).

←: To body ground

4. Install jumper cable (A) between battery negative terminal and body ground.
5. Turn ignition switch ON.
6. Check the voltage between ECM harness connector terminals as per the following.

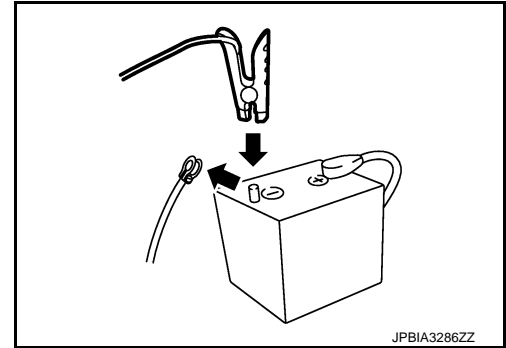

| Connector | ECM                                   |          | Voltage (V) |
|-----------|---------------------------------------|----------|-------------|
|           | +                                     | -        |             |
|           | Terminal                              | Terminal |             |
| F102      | 91<br>(Battery current sensor signal) | 95       | Approx. 2.5 |

Before measuring the terminal voltage, confirm that the battery is fully charged. Refer to [PG-135. "How to Handle Battery"](#).

Is the inspection result normal?

- YES >> INSPECTION END  
NO >> Replace battery negative cable assembly.

# P1554 BATTERY CURRENT SENSOR

< DTC/CIRCUIT DIAGNOSIS >

[VQ37VHR FOR MEXICO]

## P1554 BATTERY CURRENT SENSOR

### DTC Logic

INFOID:000000007730016

### DTC DETECTION LOGIC

| DTC No. | Trouble diagnosis name             | DTC detecting condition  | Possible cause   |
|---------|------------------------------------|--|--|
| P1554   | Battery current sensor performance | The output voltage of the battery current sensor is lower than the specified value while the battery voltage is high enough. | <ul style="list-style-type: none"> <li>• Harness or connectors (Battery current sensor circuit is open or shorted.) [CKP sensor (POS) circuit is open or shorted.] [CMP sensor (PHASE) (bank 2) circuit is open or shorted.] (APP sensor 2 circuit is shorted.) (EVAP control system pressure sensor circuit is shorted.) (Refrigerant pressure sensor circuit is shorted.)</li> <li>• Battery current sensor</li> <li>• Crankshaft position sensor (POS)</li> <li>• Camshaft position sensor (PHASE) (bank 2)</li> <li>• Accelerator pedal position sensor</li> <li>• EVAP control system pressure sensor</li> <li>• Refrigerant pressure sensor</li> </ul> |

### DTC CONFIRMATION PROCEDURE

#### 1. PERFORM COMPONENT FUNCTION CHECK

Perform component function check. Refer to [EC-879. "Component Function Check"](#).

#### NOTE:

Use component function check to check the overall function of the battery current sensor circuit. During this check, a 1st trip DTC might not be confirmed.

Is the inspection result normal?

YES >> INSPECTION END

NO >> Go to [EC-880. "Diagnosis Procedure"](#).

### Component Function Check

INFOID:000000007730017

#### 1. PRECONDITIONING

#### TESTING CONDITION:

- Before performing the following procedure, confirm that battery voltage is more than 12.8 V at idle.
- Before performing the following procedure, confirm that all load switches and A/C switch are turned OFF.

>> GO TO 2.

#### 2. PERFORM COMPONENT FUNCTION CHECK

##### With CONSULT

1. Start engine and let it idle.
2. Select "BAT CUR SEN" in "DATA MONITOR" mode with CONSULT.
3. Check "BAT CUR SEN" indication for 10 seconds.  
"BAT CUR SEN" should be above 2,300 mV at least once.

##### Without CONSULT

1. Start engine and let it idle.
2. Check the voltage between ECM harness connector terminals as per the following.

| Connector | ECM                                   |          | Voltage (V)             |
|-----------|---------------------------------------|----------|-------------------------|
|           | +                                     | -        |                         |
|           | Terminal                              | Terminal |                         |
| F102      | 91<br>(Battery current sensor signal) | 95       | Above 2.3 at least once |

Is the inspection result normal?

# P1554 BATTERY CURRENT SENSOR

[VQ37VHR FOR MEXICO]

< DTC/CIRCUIT DIAGNOSIS >

INFOID:000000007730018

- YES >> INSPECTION END  
NO >> Go to [EC-880, "Diagnosis Procedure"](#)

## Diagnosis Procedure

### 1. CHECK GROUND CONNECTION

1. Turn ignition switch OFF.
2. Check ground connection M95. Refer to Ground Inspection in [GI-47, "Circuit Inspection"](#).

Is the inspection result normal?

- YES >> GO TO 2.  
NO >> Repair or replace ground connection.

### 2. CHECK BATTERY CURRENT SENSOR POWER SUPPLY CIRCUIT-I

1. Disconnect battery current sensor harness connector.
2. Turn ignition switch ON.
3. Check the voltage between battery current sensor harness connector and ground.

| Battery current sensor |          | Ground | Voltage (V) |
|------------------------|----------|--------|-------------|
| Connector              | Terminal |        |             |
| E21                    | 1        | Ground | Approx. 5   |

Is the inspection result normal?

- YES >> GO TO 9.  
NO >> GO TO 3.

### 3. CHECK BATTERY CURRENT SENSOR POWER SUPPLY CIRCUIT-II

1. Turn ignition switch OFF.
2. Disconnect ECM harness connector.
3. Check the continuity between battery current sensor harness connector and ECM harness connector.

| Battery current sensor |          | ECM       |          | Continuity |
|------------------------|----------|-----------|----------|------------|
| Connector              | Terminal | Connector | Terminal |            |
| E21                    | 1        | F102      | 64       | Existed    |

Is the inspection result normal?

- YES >> GO TO 5.  
NO >> GO TO 4.

### 4. DETECT MALFUNCTIONING PART

Check the following.

- Harness connectors F40, E20
- Harness for open between battery current sensor and ECM

>> Repair open circuit.

### 5. CHECK SENSOR POWER SUPPLY CIRCUIT

Check harness for short to power and short to ground, between the following terminals.

| ECM       |          | Sensor                      |           |          |
|-----------|----------|-----------------------------|-----------|----------|
| Connector | Terminal | Name                        | Connector | Terminal |
| F101      | 46       | CKP sensor (POS)            | F2        | 1        |
| F102      | 64       | CMP sensor (PHASE) (bank 2) | F18       | 1        |
|           |          | Battery current sensor      | E21       |          |



# P1554 BATTERY CURRENT SENSOR

< DTC/CIRCUIT DIAGNOSIS >

[VQ37VHR FOR MEXICO]

| ECM       |          | Sensor                              |  |                                    |
|-----------|----------|-------------------------------------|--|------------------------------------|
| Connector | Terminal | Name                                | Connector                              | Terminal                           |
| M107      | 103      | APP sensor                          | M153 <sup>*1</sup><br>M9 <sup>*2</sup> | 3 <sup>*1</sup><br>6 <sup>*2</sup> |
|           |          | EVAP control system pressure sensor | B73                                    | 3                                  |
|           | 107      | Refrigerant pressure sensor         | E77                                    | 3                                  |

\*1: With ICC

\*2: Without ICC

Is the inspection result normal?

YES >> GO TO 6.

NO >> Repair short to ground or short to power in harness or connectors.

## 6. CHECK COMPONENTS

Check the following.

- Crankshaft position sensor (POS) (Refer to [EC-781, "Component Inspection"](#).)
- Camshaft position sensor (PHASE) (bank 2) (Refer to [EC-786, "Component Inspection"](#).)
- Refrigerant pressure sensor (Refer to [EC-967, "Diagnosis Procedure"](#).)

Is the inspection result normal?

YES >> GO TO 7.

NO >> Replace malfunctioning component.

## 7. CHECK APP SENSOR

Refer to [EC-882, "Component Inspection"](#).

Is the inspection result normal?

YES >> GO TO 14.

NO >> GO TO 8.

## 8. REPLACE ACCELERATOR PEDAL ASSEMBLY

1. Replace accelerator pedal assembly.
2. Go to [EC-920, "Special Repair Requirement"](#).

>> INSPECTION END

## 9. CHECK BATTERY CURRENT SENSOR GROUND CIRCUIT FOR OPEN AND SHORT

1. Turn ignition switch OFF.
2. Disconnect ECM harness connector.
3. Check the continuity between battery current sensor harness connector and ECM harness connector.

| Battery current sensor |          | ECM       |          | Continuity |
|------------------------|----------|-----------|----------|------------|
| Connector              | Terminal | Connector | Terminal |            |
| E21                    | 3        | F102      | 95       | Existed    |

4. Also check harness for short to ground and short to power.

Is the inspection result normal?

YES >> GO TO 11.

NO >> GO TO 10.

## 10. DETECT MALFUNCTIONING PART

Check the following.

- Harness connectors E20, F40
- Harness for open or short between battery current sensor and ECM

>> Repair open circuit, short to ground or short to power in harness or connectors.

## 11. CHECK BATTERY CURRENT SENSOR INPUT SIGNAL CIRCUIT FOR OPEN AND SHORT

# P1554 BATTERY CURRENT SENSOR

< DTC/CIRCUIT DIAGNOSIS >

[VQ37VHR FOR MEXICO]

1. Check the continuity between battery current sensor harness connector and ECM harness connector.

| Battery current sensor |          | ECM       |          | Continuity |
|------------------------|----------|-----------|----------|------------|
| Connector              | Terminal | Connector | Terminal |            |
| E21                    | 4        | F102      | 91       | Existed    |

2. Also check harness for short to ground and short to power.

Is the inspection result normal?

YES >> GO TO 13.

NO >> GO TO 12.

## 12. DETECT MALFUNCTIONING PART

Check the following.

- Harness connectors E20, F40
- Harness for open or short between battery current sensor and ECM

>> Repair open circuit, short to ground or short to power in harness or connectors.

## 13. CHECK BATTERY CURRENT SENSOR

Refer to [EC-882, "Component Inspection"](#).

Is the inspection result normal?

YES >> GO TO 14.

NO >> Replace battery negative cable assembly.

## 14. CHECK INTERMITTENT INCIDENT

Refer to [GI-44, "Intermittent Incident"](#).

>> INSPECTION END

## Component Inspection

INFOID:000000007730019

### 1. CHECK BATTERY CURRENT SENSOR

1. Turn ignition switch OFF.
2. Reconnect harness connectors disconnected.
3. Disconnect battery negative cable (1).

←: To body ground

4. Install jumper cable (A) between battery negative terminal and body ground.
5. Turn ignition switch ON.
6. Check the voltage between ECM harness connector terminals as per the following.

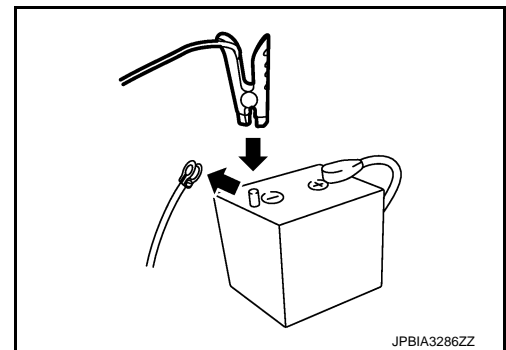

| Connector | ECM                                   |          | Voltage (V) |
|-----------|---------------------------------------|----------|-------------|
|           | +                                     | -        |             |
|           | Terminal                              | Terminal |             |
| F102      | 91<br>(Battery current sensor signal) | 95       | Approx. 2.5 |

Before measuring the terminal voltage, confirm that the battery is fully charged. Refer to [PG-135, "How to Handle Battery"](#).

Is the inspection result normal?

YES >> INSPECTION END

NO >> Replace battery negative cable assembly.

# P1556, P1557 BATTERY TEMPERATURE SENSOR

< DTC/CIRCUIT DIAGNOSIS >

[VQ37VHR FOR MEXICO]

## P1556, P1557 BATTERY TEMPERATURE SENSOR

### DTC Logic

INFOID:000000007730020

### DTC DETECTION LOGIC

| DTC No. | Trouble diagnosis name<br>(Trouble diagnosis content)               | DTC detecting condition   | Possible cause  |
|---------|---|---|---|
| P1556   | BAT TMP SEN/CIRC<br>(Battery temperature sensor circuit low input)  | Signal voltage from Battery temperature sensor remains 0.16V or less for 5 seconds or more. | <ul style="list-style-type: none"> <li>• Harness or connectors<br/>[Battery current sensor (Battery temperature sensor) circuit is shorted.]<br/>(Crankshaft position sensor circuit is open or shorted.)<br/>[Camshaft position sensor (bank 2) circuit is shorted.]<br/>(Accelerator pedal position sensor 2 circuit is shorted.)<br/>(EVAP control system pressure sensor circuit is shorted.)<br/>(Refrigerant pressure sensor circuit is shorted.)</li> <li>• Battery current sensor (Battery temperature sensor)</li> <li>• Crankshaft position sensor</li> <li>• Camshaft position sensor (bank 2)</li> <li>• Accelerator pedal position sensor 2</li> <li>• EVAP control system pressure sensor</li> <li>• Refrigerant pressure sensor</li> </ul> |
| P1557   | BAT TMP SEN/CIRC<br>(Battery temperature sensor circuit high input) | Signal voltage from Battery temperature sensor remains 4.84V or more for 5 seconds or more. |   |

### DTC CONFIRMATION PROCEDURE

#### 1. PRECONDITIONING

Turn ignition switch OFF and wait at least 10 seconds.

>> GO TO 2.

#### 2. PERFORM DTC CONFIRMATION PROCEDURE

1. Start the engine and let it idle at least 10 seconds.
2. Check 1st trip DTC.

Is 1st trip DTC detected?

YES >> Proceed to [EC-883, "Diagnosis Procedure"](#).

NO >> INSPECTION END

### Diagnosis Procedure

INFOID:000000007730021

#### 1. CHECK BATTERY TEMPERATURE SENSOR INPUT SIGNAL CIRCUIT-I

1. Disconnect battery current sensor harness connector.
2. Turn ignition switch ON.
3. Check the voltage between battery current sensor harness connector and ground.

| Battery current sensor |          | Ground | Voltage (V) |
|------------------------|----------|--------|-------------|
| Connector              | Terminal |        |             |
| E21                    | 2        | Ground | Approx. 5 V |

Is the inspection result normal?

YES >> GO TO 7.

NO >> GO TO 2.

#### 2. CHECK BATTERY TEMPERATURE SENSOR INPUT SIGNAL CIRCUIT-II

1. Turn ignition switch ON.
2. Disconnect ECM harness connector.
3. Check the continuity between battery current sensor harness connector and ECM harness connector.

# P1556, P1557 BATTERY TEMPERATURE SENSOR

< DTC/CIRCUIT DIAGNOSIS >

[VQ37VHR FOR MEXICO]

| Battery current sensor |          | ECM       |          | Continuity |
|------------------------|----------|-----------|----------|------------|
| Connector              | Terminal | Connector | Terminal |            |
| E21                    | 2        | F102      | 83       | Existed    |

Is the inspection result normal?

YES >> GO TO 3.

NO >> Repair open circuit.

## 3.CHECK SENSOR POWER SUPPLY CIRCUIT

Check harness for short to power and short to ground, between the following terminals.

| ECM       |          | Sensor                              |  |                                    |
|-----------|----------|-------------------------------------|--|------------------------------------|
| Connector | Terminal | Name                                | Connector                              | Terminal                           |
| F101      | 46       | CKP sensor (POS)                    | F2                                     | 1                                  |
| F102      | 64       | CMP sensor (PHASE) (bank 2)         | F18                                    | 1                                  |
|           |          | Battery current sensor              | E21                                    |                                    |
| M107      | 103      | APP sensor                          | M153 <sup>*1</sup><br>M9 <sup>*2</sup> | 3 <sup>*1</sup><br>6 <sup>*2</sup> |
|           |          | EVAP control system pressure sensor | B73                                    | 3                                  |
|           | 107      | Refrigerant pressure sensor         | E77                                    | 3                                  |

\*1: With ICC

\*2: Without ICC

Is the inspection result normal?

YES >> GO TO 4.

NO >> Repair short to ground or short to power in harness or connectors.

## 4.CHECK COMPONENTS

Check the following.

- Camshaft position sensor (bank 2) (Refer to [EC-786, "Component Inspection"](#).)
- CKP sensor (Refer to [EC-781, "Component Inspection"](#).)
- Battery current sensor (Refer to [EC-870, "Component Inspection"](#).)
- Refrigerant pressure sensor (Refer to [EC-967, "Diagnosis Procedure"](#).)

Is the inspection result normal?

YES >> GO TO 5.

NO >> Replace malfunctioning component.

## 5.CHECK APP SENSOR

Refer to [EC-920, "Component Inspection"](#).

Is the inspection result normal?

YES >> GO TO 9.

NO >> GO TO 6.

## 6.REPLACE ACCELERATOR PEDAL ASSEMBLY

Replace accelerator pedal assembly.

>> INSPECTION END

## 7.CHECK BATTERY TEMPERATURE SENSOR GROUND CIRCUIT FOR OPEN AND SHORT

1. Turn ignition switch OFF.
2. Disconnect ECM harness connector.
3. Check the continuity between battery current sensor harness connector and ECM harness connector.

# P1556, P1557 BATTERY TEMPERATURE SENSOR

< DTC/CIRCUIT DIAGNOSIS >

[VQ37VHR FOR MEXICO]

| Battery current sensor |          | ECM       |          | Continuity |
|------------------------|----------|-----------|----------|------------|
| Connector              | Terminal | Connector | Terminal |            |
| E21                    | 3        | M160      | 150      | Existed    |

4. Also check harness for short to ground and short to power.

Is the inspection result normal?

YES >> GO TO 8.

NO >> Repair open circuit, short to ground or short to power in harness or connectors.

## 8.CHECK BATTERY TEMPERATURE SENSOR

Refer to [EC-885, "Component Inspection \(Battery Temperature Sensor\)"](#).

Is the inspection result normal?

YES >> GO TO 9.

NO >> Replace battery negative cable assembly.

## 9.CHECK INTERMITTENT INCIDENT

Refer to [GI-44, "Intermittent Incident"](#).

>> INSPECTION END

## Component Inspection (Battery Temperature Sensor)

INFOID:000000007730022

## 1.CHECK BATTERY TEMPERATURE SENSOR

1. Turn ignition switch OFF.
2. Disconnect battery current sensor.
3. Check the resistance between battery current sensor connector terminals.

| Battery current sensor |   | Resistance   |
|------------------------|---|--|
| +                      | - |  |
| Terminal               |   |  |
| 2                      | 3 | continuity with the resistance value 100 Ω or more |

Is the inspection result normal?

YES >> INSPECTION END

NO >> Replace battery negative cable assembly.

# P1564 ASCD STEERING SWITCH

< DTC/CIRCUIT DIAGNOSIS >

[VQ37VHR FOR MEXICO]

## P1564 ASCD STEERING SWITCH

### DTC Logic

INFOID:000000007730023

#### DTC DETECTION LOGIC

##### NOTE:

If DTC P1564 is displayed with DTC P0605, first perform the trouble diagnosis for DTC P0605. Refer to [EC-819, "DTC Logic"](#).

| DTC No. | Trouble diagnosis name | DTC detecting condition  | Possible cause  |
|---------|------------------------|--|---|
| P1564   | ASCD steering switch   | <ul style="list-style-type: none"><li>• An excessively high voltage signal from the ASCD steering switch is sent to ECM.</li><li>• ECM detects that input signal from the ASCD steering switch is out of the specified range.</li><li>• ECM detects that the ASCD steering switch is stuck ON.</li></ul> | <ul style="list-style-type: none"><li>• Harness or connectors (The switch circuit is open or shorted.)</li><li>• ASCD steering switch</li><li>• ECM</li></ul> |

#### DTC CONFIRMATION PROCEDURE

##### 1. PRECONDITIONING

If DTC Confirmation Procedure has been previously conducted, always perform the following procedure before conducting the next test.

1. Turn ignition switch OFF and wait at least 10 seconds.
2. Turn ignition switch ON.
3. Turn ignition switch OFF and wait at least 10 seconds.

>> GO TO 2.

##### 2. PERFORM DTC CONFIRMATION PROCEDURE

1. Turn ignition switch ON and wait at least 10 seconds.
2. Press MAIN switch for at least 10 seconds, then release it and wait at least 10 seconds.
3. Press CANCEL switch for at least 10 seconds, then release it and wait at least 10 seconds.
4. Press RESUME/ACCELERATE switch for at least 10 seconds, then release it and wait at least 10 seconds.
5. Press SET/COAST switch for at least 10 seconds, then release it and wait at least 10 seconds.
6. Check DTC.

Is DTC detected?

- YES >> Go to [EC-886, "Diagnosis Procedure"](#).  
NO >> INSPECTION END

#### Diagnosis Procedure

INFOID:000000007730024

##### 1. CHECK GROUND CONNECTION

1. Turn ignition switch OFF.
2. Check ground connection M95. Refer to Ground Inspection in [GI-47, "Circuit Inspection"](#).

Is the inspection result normal?

- YES >> GO TO 2.  
NO >> Repair or replace ground connection.

##### 2. CHECK ASCD STEERING SWITCH CIRCUIT

###### With CONSULT

1. Turn ignition switch ON.
2. Select "MAIN SW", "CANCEL SW", "RESUME/ACC SW" and "SET SW" in "DATA MONITOR" mode with CONSULT.
3. Check each item indication under the following conditions.

# P1564 ASCD STEERING SWITCH

< DTC/CIRCUIT DIAGNOSIS >

[VQ37VHR FOR MEXICO]

| Monitor item  | Condition                |          | Indication |
|---------------|--------------------------|----------|------------|
| MAIN SW       | MAIN switch              | Pressed  | ON         |
|               |                          | Released | OFF        |
| CANCEL SW     | CANCEL switch            | Pressed  | ON         |
|               |                          | Released | OFF        |
| RESUME/ACC SW | RESUME/ACCELERATE switch | Pressed  | ON         |
|               |                          | Released | OFF        |
| SET SW        | SET/COAST switch         | Pressed  | ON         |
|               |                          | Released | OFF        |

**⊗ Without CONSULT**

1. Turn ignition switch ON.
2. Check the voltage between ECM harness connector terminals as per the following.

| Connector | ECM                                  |          | Condition                            | Voltage (V) |
|-----------|--------------------------------------|----------|--------------------------------------|-------------|
|           | +                                    | -        |                                      |             |
|           | Terminal                             | Terminal |                                      |             |
| M107      | 101<br>(ASCD steering switch signal) | 108      | MAIN switch: Pressed                 | Approx. 0   |
|           |                                      |          | CANCEL switch: Pressed               | Approx. 1   |
|           |                                      |          | SET/COAST switch: Pressed            | Approx. 2   |
|           |                                      |          | RESUME/ACCELERATE switch: Pressed    | Approx. 3   |
|           |                                      |          | All ASCD steering switches: Released | Approx. 4   |

Is the inspection result normal?

- YES >> GO TO 8.  
NO >> GO TO 3.

### 3. CHECK ASCD STEERING SWITCH GROUND CIRCUIT FOR OPEN AND SHORT

1. Turn ignition switch OFF.
2. Disconnect ECM harness connector.
3. Disconnect combination switch harness connector.
4. Check the continuity between combination switch and ECM harness connector.

| Combination switch | ECM       |          | Continuity |
|--------------------|-----------|----------|------------|
|                    | Connector | Terminal |            |
| Terminal<br>16     | M107      | 108      | Existed    |

5. Also check harness for short to ground and short to power.

Is the inspection result normal?

- YES >> GO TO 5.  
NO >> GO TO 4.

### 4. DETECT MALFUNCTIONING PART

Check the following.

- Combination switch (spiral cable)
- Harness for open and short between ECM and combination switch

>> Repair open circuit, short to ground or short to power in harness or connectors.

### 5. CHECK ASCD STEERING SWITCH INPUT SIGNAL CIRCUIT FOR OPEN AND SHORT

1. Check the continuity between combination switch and ECM harness connector.

# P1564 ASCD STEERING SWITCH

< DTC/CIRCUIT DIAGNOSIS >

[VQ37VHR FOR MEXICO]

| Combination switch |           | ECM      |  | Continuity |
|--------------------|-----------|----------|--|------------|
| Terminal           | Connector | Terminal |  |            |
| 13                 | M107      | 101      |  | Existed    |

2. Also check harness for short to ground and short to power.

Is the inspection result normal?

YES >> GO TO 7.

NO >> GO TO 6.

## 6. DETECT MALFUNCTIONING PART

Check the following.

- Combination switch (spiral cable)
- Harness for open and short between ECM and combination switch

>> Repair open circuit, short to ground or short to power in harness or connectors.

## 7. CHECK ASCD STEERING SWITCH

Refer to [EC-888, "Component Inspection"](#).

Is the inspection result normal?

YES >> GO TO 8.

NO >> Replace ASCD steering switch. Refer to [ST-31, "Exploded View"](#).

## 8. CHECK INTERMITTENT INCIDENT

Refer to [GI-44, "Intermittent Incident"](#).

>> INSPECTION END

## Component Inspection

INFOID:000000007730025

## 1. CHECK ASCD STEERING SWITCH

1. Turn ignition switch OFF.
2. Disconnect combination switch (spiral cable) harness connector M303.
3. Check resistance between combination switch harness connector terminals under the following conditions.

| Combination switch |           | Condition                            | Resistance ( $\Omega$ ) |
|--------------------|-----------|--------------------------------------|-------------------------|
| Connector          | Terminals |                                      |                         |
| M303               | 13 and 16 | MAIN switch: Pressed                 | Approx. 0               |
|                    |           | CANCEL switch: Pressed               | Approx. 250             |
|                    |           | SET/COAST switch: Pressed            | Approx. 660             |
|                    |           | RESUME/ACCELERATE switch: Pressed    | Approx. 1,480           |
|                    |           | All ASCD steering switches: Released | Approx. 4,000           |

Is the inspection result normal?

YES >> INSPECTION END

NO >> Replace ASCD steering switch. Refer to [ST-31, "Exploded View"](#).



# P1564 ICC STEERING SWITCH

< DTC/CIRCUIT DIAGNOSIS >

[VQ37VHR FOR MEXICO]

## P1564 ICC STEERING SWITCH

### DTC Logic

INFOID:000000007730026

#### DTC DETECTION LOGIC

##### NOTE:

If DTC P1564 is displayed with DTC P0605, first perform the trouble diagnosis for DTC P0605. Refer to [EC-819, "DTC Logic"](#).

| DTC No. | Trouble diagnosis name | DTC detecting condition   | Possible cause   |
|---------|------------------------|---|--|
| P1564   | ICC steering switch    | <ul style="list-style-type: none"><li>An excessively high voltage signal from the ICC steering switch is sent to ECM.</li><li>ECM detects that input signal from the ICC steering switch is out of the specified range.</li><li>ECM detects that the ICC steering switch is stuck ON.</li></ul> | <ul style="list-style-type: none"><li>Harness or connectors (The switch circuit is open or shorted.)</li><li>ICC steering switch</li><li>ECM</li></ul> |

#### DTC CONFIRMATION PROCEDURE

##### 1. PRECONDITIONING

If DTC Confirmation Procedure has been previously conducted, always perform the following procedure before conducting the next test.

- Turn ignition switch OFF and wait at least 10 seconds.
- Turn ignition switch ON.
- Turn ignition switch OFF and wait at least 10 seconds.

>> GO TO 2.

##### 2. PERFORM DTC CONFIRMATION PROCEDURE

- Turn ignition switch ON and wait at least 10 seconds.
- Press MAIN switch for at least 10 seconds, then release it and wait at least 10 seconds.
- Press DYNAMIC DRIVE ASSISTANCE SYSTEMS switch for at least 10 seconds, then release it and wait at least 10 seconds.
- Press CANCEL switch for at least 10 seconds, then release it and wait at least 10 seconds.
- Press RESUME/ACCELERATE switch for at least 10 seconds, then release it and wait at least 10 seconds.
- Press SET/COAST switch for at least 10 seconds, then release it and wait at least 10 seconds.
- Press DISTANCE switch for at least 10 seconds, then release it and wait at least 10 seconds.
- Check DTC.

##### Is DTC detected?

YES >> Go to [EC-889, "Diagnosis Procedure"](#).

NO >> INSPECTION END

#### Diagnosis Procedure

INFOID:000000007730027

##### 1. CHECK GROUND CONNECTION

- Turn ignition switch OFF.
- Check ground connection M95. Refer to Ground Inspection in [GI-47, "Circuit Inspection"](#).

##### Is the inspection result normal?

YES >> GO TO 2.

NO >> Repair or replace ground connection.

##### 2. CHECK ICC STEERING SWITCH CIRCUIT

###### With CONSULT

- Turn ignition switch ON.
- Select "MAIN SW", "DYNAMIC DRIVE ASSISTANCE SYSTEMS SW", "CANCEL SW", "RESUME/ACC SW", "SET SW" and "DIST SW" in "DATA MONITOR" mode with CONSULT.
- Check each item indication under the following conditions.

# P1564 ICC STEERING SWITCH

< DTC/CIRCUIT DIAGNOSIS >

[VQ37VHR FOR MEXICO]

| Monitor item                        | Condition                               | Indication |     |
|-------------------------------------|---|------------|-----|
| MAIN SW                             | MAIN switch                             | Pressed    | ON  |
|                                     |   | Released   | OFF |
| DYNAMIC DRIVE ASSISTANCE SYSTEMS SW | DYNAMIC DRIVE ASSISTANCE SYSTEMS switch | Pressed    | ON  |
|                                     |   | Released   | OFF |
| CANCEL SW                           | CANCEL switch                           | Pressed    | ON  |
|                                     |   | Released   | OFF |
| RESUME/ACC SW                       | RESUME/ACCELERATE switch                | Pressed    | ON  |
|                                     |   | Released   | OFF |
| SET SW                              | SET/COAST switch                        | Pressed    | ON  |
|                                     |   | Released   | OFF |
| DIST SW                             | DISTANCE switch                         | Pressed    | ON  |
|                                     |   | Released   | OFF |

## ⊗ Without CONSULT

- Turn ignition switch ON.
- Check the voltage between ECM harness connector terminals as per the following.

| ECM       |                                     |          | Condition  | Voltage (V) |
|-----------|-------------------------------------|----------|--|-------------|
| Connector | +                                   | -        |  |             |
|           | Terminal                            | Terminal |  |             |
| M107      | 101<br>(ICC steering switch signal) | 108      | MAIN switch: Pressed                             | Approx. 0   |
|           |                                     |          | DYNAMIC DRIVE ASSISTANCE SYSTEMS switch: Pressed | Approx. 1.0 |
|           |                                     |          | CANCEL switch: Pressed                           | Approx. 1.9 |
|           |                                     |          | DISTANCE switch: Pressed                         | Approx. 2.6 |
|           |                                     |          | SET/COAST switch: Pressed                        | Approx. 3.2 |
|           |                                     |          | RESUME/ACCELERATE switch: Pressed                | Approx. 3.7 |
|           |                                     |          | All ICC steering switches: Released              | Approx. 4.2 |

Is the inspection result normal?

- YES >> GO TO 8.  
NO >> GO TO 3.

## 3. CHECK ICC STEERING SWITCH GROUND CIRCUIT FOR OPEN AND SHORT

- Turn ignition switch OFF.
- Disconnect ECM harness connector.
- Disconnect combination switch harness connector.
- Check the continuity between combination switch and ECM harness connector.

| Combination switch | ECM      |           | Continuity |
|--------------------|----------|-----------|------------|
|                    | Terminal | Connector |            |
| 16                 | M107     | 108       | Existed    |

- Also check harness for short to ground and short to power.

Is the inspection result normal?

- YES >> GO TO 5.  
NO >> GO TO 4.

## 4. DETECT MALFUNCTIONING PART

Check the following.

- Combination switch (spiral cable)

# P1564 ICC STEERING SWITCH

< DTC/CIRCUIT DIAGNOSIS >

[VQ37VHR FOR MEXICO]

- Harness for open and short between ECM and combination switch

>> Repair open circuit, short to ground or short to power in harness or connectors.

## 5.CHECK ICC STEERING SWITCH INPUT SIGNAL CIRCUIT FOR OPEN AND SHORT

1. Check the continuity between combination switch and ECM harness connector.

| Combination switch |           | ECM      |  | Continuity |
|--------------------|-----------|----------|--|------------|
| Terminal           | Connector | Terminal |  |            |
| 13                 | M107      | 101      |  | Existed    |

2. Also check harness for short to ground and short to power.

Is the inspection result normal?

YES >> GO TO 7.

NO >> GO TO 6.

## 6.DETECT MALFUNCTIONING PART

Check the following.

- Combination switch (spiral cable)
- Harness for open and short between ECM and combination switch

>> Repair open circuit, short to ground or short to power in harness or connectors.

## 7.CHECK ICC STEERING SWITCH

Refer to [EC-891, "Component Inspection"](#).

Is the inspection result normal?

YES >> GO TO 8.

NO >> Replace ICC steering switch. Refer to [ST-31, "Exploded View"](#).

## 8.CHECK INTERMITTENT INCIDENT

Refer to [GI-44, "Intermittent Incident"](#).

>> INSPECTION END

## Component Inspection

INFOID:000000007730028

### 1.CHECK ICC STEERING SWITCH

1. Turn ignition switch OFF.
2. Disconnect combination switch (spiral cable) harness connector M303.
3. Check resistance between combination switch harness connector terminals under the following conditions.

| Combination switch |           | Condition  | Resistance ( $\Omega$ ) |
|--------------------|-----------|--|-------------------------|
| Connector          | Terminals |  |                         |
| M303               | 13 and 16 | MAIN switch: Pressed                             | Approx. 0               |
|                    |           | DYNAMIC DRIVE ASSISTANCE SYSTEMS switch: Pressed | Approx. 270             |
|                    |           | CANCEL switch: Pressed                           | Approx. 620             |
|                    |           | DISTANCE switch: Pressed                         | Approx. 1,090           |
|                    |           | SET/COAST switch: Pressed                        | Approx. 1,810           |
|                    |           | RESUME/ACCELERATE switch: Pressed                | Approx. 2,990           |
|                    |           | All ICC steering switches: Released              | Approx. 5,420           |

Is the inspection result normal?

YES >> INSPECTION END

## P1564 ICC STEERING SWITCH

< DTC/CIRCUIT DIAGNOSIS >

[VQ37VHR FOR MEXICO]

---

NO >> Replace ICC steering switch. Refer to [ST-31, "Exploded View"](#).

## P1568 ICC FUNCTION

### DTC Logic

INFOID:000000007730029

#### DTC DETECTION LOGIC

**NOTE:**

- If DTC P1568 is displayed with DTC UXXXX, first perform the trouble diagnosis for DTC UXXXX.
- If DTC P1568 is displayed with DTC P0605, first perform the trouble diagnosis for DTC P0605. Refer to [EC-819, "DTC Logic"](#).
- If DTC P1568 is displayed with DTC P0607, first perform the trouble diagnosis for DTC P0607. Refer to [EC-821, "DTC Logic"](#).

| DTC No. | Trouble Diagnosis Name | DTC Detecting Condition  | Possible Cause   |
|---------|------------------------|--|--|
| P1568   | ICC function           | ECM detects a difference between signals from ADAS control unit is out of specified range. | <ul style="list-style-type: none"> <li>• Harness or connectors (The CAN communication line is open or shorted.)</li> <li>• ADAS control unit</li> <li>• ECM</li> </ul> |

#### DTC CONFIRMATION PROCEDURE

##### 1. PRECONDITIONING

If DTC Confirmation Procedure has been previously conducted, always perform the following procedure before conducting the next test.

1. Turn ignition switch OFF and wait at least 10 seconds.
2. Turn ignition switch ON.
3. Turn ignition switch OFF and wait at least 10 seconds.

**TESTING CONDITION:**

**Step 4 may be conducted with the drive wheels lifted in the shop or by driving the vehicle. If a road test is expected to be easier, it is unnecessary to lift the vehicle.**

>> GO TO 2.

##### 2. PERFORM DTC CONFIRMATION PROCEDURE

1. Turn ignition switch ON.
2. Press MAIN switch on ICC steering switch.
3. Drive the vehicle at more than 40 km/h (25 MPH).

**CAUTION:**

**Always drive vehicle at a safe speed.**

4. Press SET/COAST switch.
5. Check DTC.

Is DTC detected?

- YES >> Go to [EC-893, "Diagnosis Procedure"](#).  
 NO >> INSPECTION END

#### Diagnosis Procedure

INFOID:000000007730030

##### 1. REPLACE ADAS CONTROL UNIT

1. Replace ADAS control unit.
2. Perform [CCS-70, "Work Procedure \(Vehicle-To-Vehicle Distance Control Mode\)"](#).
3. Check DTC of ADAS control unit. Refer to [CCS-31, "On Board Diagnosis Function"](#).

>> INSPECTION END

# P1572 ASCD BRAKE SWITCH

< DTC/CIRCUIT DIAGNOSIS >

[VQ37VHR FOR MEXICO]

## P1572 ASCD BRAKE SWITCH

### Description

INFOID:000000007730031

When the brake pedal is depressed, ASCD brake switch is turned OFF and stop lamp switch is turned ON. ECM detects the state of the brake pedal by those two types of input (ON/OFF signal). Refer to [EC-578, "AUTOMATIC SPEED CONTROL DEVICE \(ASCD\) : System Description"](#) for the ASCD function.

### DTC Logic

INFOID:000000007730032

### DTC DETECTION LOGIC

#### NOTE:

- If DTC P1572 is displayed with DTC P0605, first perform the trouble diagnosis for DTC P0605. Refer to [EC-819, "DTC Logic"](#).
- This self-diagnosis has the one trip detection logic. When malfunction A is detected, DTC is not stored in ECM memory. And in that case, 1st trip DTC and 1st trip freeze frame data are displayed. 1st trip DTC is erased when ignition switch is turned OFF. And even when malfunction A is detected in two consecutive trips, DTC is not stored in ECM memory.

| DTC No. | Trouble diagnosis name | DTC detecting condition |  | Possible cause   |
|---------|------------------------|-------------------------|--|--|
| P1572   | ASCD brake switch      | A)                      | When the vehicle speed is above 30 km/h (19 MPH), ON signals from the stop lamp switch and the ASCD brake switch are sent to the ECM at the same time. | <ul style="list-style-type: none"><li>• Harness or connectors (The stop lamp switch circuit is shorted.)</li><li>• Harness or connectors (The ASCD brake switch circuit is shorted.)</li><li>• Stop lamp switch</li><li>• ASCD brake switch</li><li>• Incorrect stop lamp switch installation</li><li>• Incorrect ASCD brake switch installation</li><li>• ECM</li></ul> |
|         |                        | B)                      | ASCD brake switch signal is not sent to ECM for extremely long time while the vehicle is being driven.   |  |

### DTC CONFIRMATION PROCEDURE

#### 1. PRECONDITIONING

If DTC Confirmation Procedure has been previously conducted, always perform the following procedure before conducting the next test.

1. Turn ignition switch OFF and wait at least 10 seconds.
2. Turn ignition switch ON.
3. Turn ignition switch OFF and wait at least 10 seconds.

#### NOTE:

The procedure for malfunction B is not described. It takes an extremely long time to complete the procedure for malfunction B. By performing the procedure for malfunction A, the condition that causes malfunction B can be detected.

>> GO TO 2.

#### 2. PERFORM DTC CONFIRMATION PROCEDURE FOR MALFUNCTION A

1. Start engine (VDC switch OFF).
2. Press MAIN switch and make sure that CRUISE lamp illuminates.
3. Drive the vehicle for at least 5 consecutive seconds under the following conditions.

#### CAUTION:

**Always drive vehicle at a safe speed.**

#### NOTE:

**This procedure may be conducted with the drive wheels lifted in the shop or by driving the vehicle. If a road test is expected to be easier, it is unnecessary to lift the vehicle.**

|                |                            |
|----------------|----------------------------|
| Vehicle speed  | More than 30 km/h (19 mph) |
| Selector lever | Suitable position          |

4. Check 1st trip DTC.

# P1572 ASCD BRAKE SWITCH

[VQ37VHR FOR MEXICO]

## < DTC/CIRCUIT DIAGNOSIS >

Is 1st trip DTC detected?

- YES >> Go to [EC-895, "Diagnosis Procedure"](#).
- NO >> GO TO 3.

### 3.PERFORM DTC CONFIRMATION PROCEDURE

1. Drive the vehicle for at least 5 consecutive seconds under the following conditions.

**CAUTION:**

**Always drive vehicle at a safe speed.**

**NOTE:**

**This procedure may be conducted with the drive wheels lifted in the shop or by driving the vehicle. If a road test is expected to be easier, it is unnecessary to lift the vehicle.**

|                  |   |
|------------------|---|
| Vehicle speed    | More than 30 km/h (19 mph)  |
| Selector lever   | Suitable position   |
| Driving location | Depress the brake pedal for more than 5 seconds so as not to come off from the above-mentioned vehicle speed. |

2. Check 1st trip DTC.

Is 1st trip DTC detected?

- YES >> Go to [EC-895, "Diagnosis Procedure"](#).
- NO >> INSPECTION END

## Diagnosis Procedure

INFOID:000000007730033

### 1.CHECK OVERALL FUNCTION-I

**Ⓜ With CONSULT**

1. Turn ignition switch ON.
2. Select "BRAKE SW1" in "DATA MONITOR" mode with CONSULT.
3. Check "BRAKE SW1" indication under the following conditions.

| Monitor item | Condition   |                    | Indication |
|--------------|-------------|--------------------|------------|
| BRAKE SW1    | Brake pedal | Slightly depressed | OFF        |
|              | Brake pedal | Fully released     | ON         |

**Ⓧ Without CONSULT**

1. Turn ignition switch ON.
2. Check the voltage between ECM harness connector terminals as per the following.

| Connector | ECM                               |     | Condition                         | Voltage (V)     |
|-----------|-----------------------------------|-----|-----------------------------------|-----------------|
|           | +                                 | -   |                                   |                 |
|           | Terminal                          |     |                                   |                 |
| M107      | 126<br>(ASCD brake switch signal) | 128 | Brake pedal<br>Slightly depressed | Approx. 0       |
|           |                                   |     | Brake pedal<br>Fully released     | Battery voltage |

Is the inspection result normal?

- YES >> GO TO 2.
- NO >> GO TO 3.

### 2.CHECK OVERALL FUNCTION-II

**Ⓜ With CONSULT**

Select "BRAKE SW2" and check indication under the following conditions.

# P1572 ASCD BRAKE SWITCH

< DTC/CIRCUIT DIAGNOSIS >

[VQ37VHR FOR MEXICO]

| Monitor item | Condition   |                    | Indication |
|--------------|-------------|--------------------|------------|
| BRAKE SW2    | Brake pedal | Slightly depressed | ON         |
|              |             | Fully released     | OFF        |

**⊗ Without CONSULT**

Check the voltage between ECM harness connector terminals as per the following.

| Connector | ECM                              |          | Condition                         | Voltage (V)     |
|-----------|----------------------------------|----------|-----------------------------------|-----------------|
|           | +                                | -        |                                   |                 |
|           | Terminal                         | Terminal |                                   |                 |
| M107      | 122<br>(Stop lamp switch signal) | 128      | Brake pedal<br>Slightly depressed | Battery voltage |
|           |                                  |          | Fully released                    | Approx. 0       |

Is the inspection result normal?

YES >> GO TO 13.

NO >> GO TO 8.

### 3. CHECK ASCD BRAKE SWITCH POWER SUPPLY CIRCUIT

1. Turn ignition switch OFF.
2. Disconnect ASCD brake switch harness connector.
3. Turn ignition switch ON.
4. Check the voltage between ASCD brake switch harness connector and ground.

| ASCD brake switch |          | Ground | Voltage         |
|-------------------|----------|--------|-----------------|
| Connector         | Terminal |        |                 |
| E109              | 1        | Ground | Battery voltage |

Is the inspection result normal?

YES >> GO TO 5.

NO >> GO TO 4.

### 4. DETECT MALFUNCTIONING PART

Check the following.

- Fuse block (J/B) connector E103
- 10 A fuse (No. 3)
- Harness for open or short between ASCD brake switch and fuse

>> Repair open circuit or short to ground in harness or connectors.

### 5. CHECK ASCD BRAKE SWITCH INPUT SIGNAL CIRCUIT FOR OPEN AND SHORT

1. Turn ignition switch OFF.
2. Disconnect ECM harness connector.
3. Check the continuity between ASCD brake switch harness connector and ECM harness connector.

| ASCD brake switch |          | ECM       |          | Continuity |
|-------------------|----------|-----------|----------|------------|
| Connector         | Terminal | Connector | Terminal |            |
| E109              | 2        | M107      | 126      | Existed    |

4. Also check harness for short to ground and short to power.

Is the inspection result normal?

YES >> GO TO 7.

NO >> GO TO 6.

### 6. DETECT MALFUNCTIONING PART

Check the following.

- Harness connectors E106, M6



# P1572 ASCD BRAKE SWITCH

< DTC/CIRCUIT DIAGNOSIS >

[VQ37VHR FOR MEXICO]

- Harness for open or short between ECM and ASCD brake switch

>> Repair open circuit, short to ground or short to power in harness or connectors.

## 7. CHECK ASCD BRAKE SWITCH

Refer to [EC-898. "Component Inspection \(ASCD Brake Switch\)"](#)

Is the inspection result normal?

YES >> GO TO 13.

NO >> Replace ASCD brake switch. Refer to [BR-18. "Exploded View"](#).

## 8. CHECK STOP LAMP SWITCH POWER SUPPLY CIRCUIT

1. Turn ignition switch OFF.
2. Disconnect stop lamp switch harness connector.
3. Check the voltage between stop lamp switch harness connector and ground.

| Stop lamp switch |          | Ground | Voltage         |
|------------------|----------|--------|-----------------|
| Connector        | Terminal |        |                 |
| E110             | 1        | Ground | Battery voltage |

Is the inspection result normal?

YES >> GO TO 10.

NO >> GO TO 9.

## 9. DETECT MALFUNCTIONING PART

Check the following.

- Fuse block (J/B) connector E103
- 10A fuse (No. 7)
- Harness for open or short between stop lamp switch and battery

>> Repair open circuit, short to ground or short to power in harness or connectors.

## 10. CHECK STOP LAMP SWITCH INPUT SIGNAL CIRCUIT FOR OPEN AND SHORT

1. Disconnect ECM harness connector.
2. Check the continuity between stop lamp switch harness connector and ECM harness connector.

| Stop lamp switch |          | ECM       |          | Continuity |
|------------------|----------|-----------|----------|------------|
| Connector        | Terminal | Connector | Terminal |            |
| E110             | 2        | M107      | 122      | Existed    |

3. Also check harness for short to ground and short to power.

Is the inspection result normal?

YES >> GO TO 12.

NO >> GO TO 11.

## 11. DETECT MALFUNCTIONING PART

Check the following.

- Fuse block (J/B) connectors E103, M2
- Harness for open or short between ECM and stop lamp switch

>> Repair open circuit, short to ground or short to power in harness or connectors.

## 12. CHECK STOP LAMP SWITCH

Refer to [EC-898. "Component Inspection \(Stop Lamp Switch\)"](#)

Is the inspection result normal?

YES >> GO TO 13.

NO >> Replace stop lamp switch. Refer to [BR-18. "Exploded View"](#).

# P1572 ASCD BRAKE SWITCH

< DTC/CIRCUIT DIAGNOSIS >

[VQ37VHR FOR MEXICO]

## 13.CHECK INTERMITTENT INCIDENT

Refer to [GI-44. "Intermittent Incident"](#).

>> INSPECTION END

### Component Inspection (ASCD Brake Switch)

INFOID:000000007730034

#### 1.CHECK ASCD BRAKE SWITCH-I

1. Turn ignition switch OFF.
2. Disconnect ASCD brake switch harness connector.
3. Check the continuity between ASCD brake switch terminals under the following conditions.

| Terminals | Condition   |                    | Continuity  |
|-----------|-------------|--------------------|-------------|
| 1 and 2   | Brake pedal | Fully released     | Existed     |
|           |             | Slightly depressed | Not existed |

Is the inspection result normal?

- YES >> INSPECTION END  
NO >> GO TO 2.

#### 2.CHECK ASCD BRAKE SWITCH-II

1. Adjust ASCD brake switch installation. Refer to [BR-19. "Inspection and Adjustment"](#).
2. Check the continuity between ASCD brake switch terminals under the following conditions.

| Terminals | Condition   |                    | Continuity  |
|-----------|-------------|--------------------|-------------|
| 1 and 2   | Brake pedal | Fully released     | Existed     |
|           |             | Slightly depressed | Not existed |

Is the inspection result normal?

- YES >> INSPECTION END  
NO >> Replace ASCD brake switch. Refer to [BR-18. "Exploded View"](#).

### Component Inspection (Stop Lamp Switch)

INFOID:000000007730035

#### 1.CHECK STOP LAMP SWITCH-I

1. Turn ignition switch OFF.
2. Disconnect stop lamp switch harness connector.
3. Check the continuity between stop lamp switch terminals under the following conditions.

| Terminals | Condition   |                    | Continuity  |
|-----------|-------------|--------------------|-------------|
| 1 and 2   | Brake pedal | Fully released     | Not existed |
|           |             | Slightly depressed | Existed     |

Is the inspection result normal?

- YES >> INSPECTION END  
NO >> GO TO 2.

#### 2.CHECK STOP LAMP SWITCH-II

1. Adjust stop lamp switch installation. Refer to [BR-19. "Inspection and Adjustment"](#).
2. Check the continuity between stop lamp switch terminals under the following conditions.

| Terminals | Condition   |                    | Continuity  |
|-----------|-------------|--------------------|-------------|
| 1 and 2   | Brake pedal | Fully released     | Not existed |
|           |             | Slightly depressed | Existed     |

Is the inspection result normal?

# P1572 ASCD BRAKE SWITCH

[VQ37VHR FOR MEXICO]

< DTC/CIRCUIT DIAGNOSIS >

YES >> INSPECTION END

NO >> Replace stop lamp switch. Refer to [BR-18, "Exploded View"](#).

A

EC

C

D

E

F

G

H

I

J

K

L

M

N

O

P

# P1572 ICC BRAKE SWITCH

< DTC/CIRCUIT DIAGNOSIS >

[VQ37VHR FOR MEXICO]

## P1572 ICC BRAKE SWITCH

### DTC Logic

INFOID:000000007730036

### DTC DETECTION LOGIC

#### NOTE:

- If DTC P1572 is displayed with DTC P0605, first perform the trouble diagnosis for DTC P0605. Refer to [EC-819, "DTC Logic"](#).
- This self-diagnosis has the one trip detection logic. When malfunction A is detected, DTC is not stored in ECM memory. And in that case, 1st trip DTC and 1st trip freeze frame data are displayed. 1st trip DTC is erased when ignition switch is turned OFF. And even when malfunction A is detected in two consecutive trips, DTC is not stored in ECM memory.

| DTC No. | Trouble diagnosis name | DTC detecting condition |  | Possible cause   |
|---------|------------------------|-------------------------|--|--|
| P1572   | ICC brake switch       | A)                      | ON signals from the stop lamp switch and the ICC brake switch are sent to ECM at the same time.      | <ul style="list-style-type: none"><li>• Harness or connectors (The stop lamp switch circuit is shorted.)</li><li>• Harness or connectors (The ICC brake switch circuit is shorted.)</li><li>• Stop lamp switch</li><li>• ICC brake switch</li><li>• ICC brake hold relay</li><li>• Incorrect stop lamp switch installation</li><li>• Incorrect ICC brake switch installation</li><li>• ECM</li></ul> |
|         |                        | B)                      | ICC brake switch signal is not sent to ECM for extremely long time while the vehicle is being driven |  |

### DTC CONFIRMATION PROCEDURE

#### 1. PRECONDITIONING

If DTC Confirmation Procedure has been previously conducted, always perform the following procedure before conducting the next test.

1. Turn ignition switch OFF and wait at least 10 seconds.
2. Turn ignition switch ON.
3. Turn ignition switch OFF and wait at least 10 seconds.

#### NOTE:

The procedure for malfunction B is not described. It takes an extremely long time to complete the procedure for malfunction B. By performing the procedure for malfunction A, the condition that causes malfunction B can be detected.

>> GO TO 2.

#### 2. PERFORM DTC CONFIRMATION PROCEDURE

1. Start engine (VDC switch OFF).
2. Press MAIN switch and make sure that CRUISE lamp illuminates.
3. Drive the vehicle for at least 5 consecutive seconds under the following conditions.

#### CAUTION:

**Always drive vehicle at a safe speed.**

#### NOTE:

**This procedure may be conducted with the drive wheels lifted in the shop or by driving the vehicle. If a road test is expected to be easier, it is unnecessary to lift the vehicle.**

|                |                            |
|----------------|----------------------------|
| Vehicle speed  | More than 30 km/h (19 mph) |
| Selector lever | Suitable position          |

4. Check 1st trip DTC.

Is 1st trip DTC detected?

- YES >> Go to [EC-901, "Diagnosis Procedure"](#).  
NO >> GO TO 3.

#### 3. PERFORM DTC CONFIRMATION PROCEDURE

1. Drive the vehicle for at least 5 consecutive seconds under the following conditions.

# P1572 ICC BRAKE SWITCH

< DTC/CIRCUIT DIAGNOSIS >

[VQ37VHR FOR MEXICO]

**CAUTION:**

Always drive vehicle at a safe speed.

**NOTE:**

This procedure may be conducted with the drive wheels lifted in the shop or by driving the vehicle. If a road test is expected to be easier, it is unnecessary to lift the vehicle.

|                  |   |
|------------------|---|
| Vehicle speed    | More than 30 km/h (19 mph)  |
| Selector lever   | Suitable position   |
| Driving location | Depress the brake pedal for more than 5 seconds so as not to come off from the above-mentioned vehicle speed. |

2. Check 1st trip DTC.

Is 1st trip DTC detected?

YES >> Go to [EC-901, "Diagnosis Procedure"](#).

NO >> INSPECTION END

## Diagnosis Procedure

INFOID:000000007730037

### 1. CHECK OVERALL FUNCTION-I

**④ With CONSULT**

- Turn ignition switch ON.
- Select "BRAKE SW1" in "DATA MONITOR" mode with CONSULT.
- Check "BRAKE SW1" indication under the following conditions.

| Monitor item | Condition   |                    | Indication |
|--------------|-------------|--------------------|------------|
|              | Brake pedal | Slightly depressed |            |
| BRAKE SW1    | Brake pedal | Slightly depressed | OFF        |
|              | Brake pedal | Fully released     | ON         |

**⊗ Without CONSULT**

- Turn ignition switch ON.
- Check the voltage between ECM harness connector terminals under the following conditions.

| Connector | ECM                              |          | Condition                         | Voltage (V)     |
|-----------|----------------------------------|----------|-----------------------------------|-----------------|
|           | +                                | -        |                                   |                 |
|           | Terminal                         | Terminal |                                   |                 |
| M107      | 126<br>(ICC brake switch signal) | 128      | Brake pedal<br>Slightly depressed | Approx. 0       |
|           |                                  |          | Brake pedal<br>Fully released     | Battery voltage |

Is the inspection result normal?

YES >> GO TO 2.

NO >> GO TO 3.

### 2. CHECK OVERALL FUNCTION-II

**④ With CONSULT**

Select "BRAKE SW2" and check indication under the following conditions.

| Monitor item | Condition   |                    | Indication |
|--------------|-------------|--------------------|------------|
|              | Brake pedal | Slightly depressed |            |
| BRAKE SW2    | Brake pedal | Slightly depressed | ON         |
|              |             | Fully released     | OFF        |

**⊗ Without CONSULT**

Check the voltage between ECM harness connector terminals as per the following.

# P1572 ICC BRAKE SWITCH

< DTC/CIRCUIT DIAGNOSIS >

[VQ37VHR FOR MEXICO]

| ECM       |                                  |          | Condition   | Voltage (V)        |                 |
|-----------|----------------------------------|----------|-------------|--------------------|-----------------|
| Connector | +                                | -        |             |                    |                 |
|           | Terminal                         | Terminal |             |                    |                 |
| M107      | 122<br>(Stop lamp switch signal) | 128      | Brake pedal | Slightly depressed | Battery voltage |
|           |                                  |          |             | Fully released     | Approx. 0       |

Is the inspection result normal?

YES >> GO TO 14.

NO >> GO TO 8.

## 3. CHECK ICC BRAKE SWITCH POWER SUPPLY CIRCUIT

1. Turn ignition switch OFF.
2. Disconnect ICC brake switch harness connector.
3. Turn ignition switch ON.
4. Check the voltage between ICC brake switch harness connector and ground.

| ICC brake switch |          | Ground | Voltage         |
|------------------|----------|--------|-----------------|
| Connector        | Terminal |        |                 |
| E114             | 1        | Ground | Battery voltage |

Is the inspection result normal?

YES >> GO TO 5.

NO >> GO TO 4.

## 4. DETECT MALFUNCTIONING PART

Check the following.

- Fuse block (J/B) connector E103
- 10 A fuse (No. 3)
- Harness for open or short between ICC brake switch and fuse

>> Repair open circuit or short to ground in harness or connectors.

## 5. CHECK ICC BRAKE SWITCH INPUT SIGNAL CIRCUIT FOR OPEN AND SHORT

1. Turn ignition switch OFF.
2. Disconnect ECM harness connector.
3. Check the continuity between ICC brake switch harness connector and ECM harness connector.

| ICC brake switch |          | ECM       |          | Continuity |
|------------------|----------|-----------|----------|------------|
| Connector        | Terminal | Connector | Terminal |            |
| E114             | 2        | M107      | 126      | Existed    |

4. Also check harness for short to ground and short to power.

Is the inspection result normal?

YES >> GO TO 7.

NO >> GO TO 6.

## 6. DETECT MALFUNCTIONING PART

Check the following.

- Harness connectors E106, M6
- Harness for open or short between ICC brake switch and ECM

>> Repair open circuit, short to ground or short to power in harness or connectors.

## 7. CHECK ICC BRAKE SWITCH

Refer to [EC-904, "Component Inspection \(ICC Brake Switch\)"](#).

# P1572 ICC BRAKE SWITCH

[VQ37VHR FOR MEXICO]

< DTC/CIRCUIT DIAGNOSIS >

Is the inspection result normal?

YES >> GO TO 14.

NO >> Replace ICC brake switch. Refer to [BR-18. "Exploded View"](#).

## 8. CHECK STOP LAMP SWITCH POWER SUPPLY CIRCUIT

1. Turn ignition switch OFF.
2. Disconnect stop lamp switch harness connector.
3. Disconnect ICC brake hold relay harness connector.
4. Check the voltage between stop lamp switch harness connector and ground.

| Stop lamp switch |          | Ground | Voltage         |
|------------------|----------|--------|-----------------|
| Connector        | Terminal |        |                 |
| E110             | 1        | Ground | Battery voltage |

5. Check the voltage between ICC brake hold relay harness connector and ground.

| ICC brake hold relay |          | Ground | Voltage         |
|----------------------|----------|--------|-----------------|
| Connector            | Terminal |        |                 |
| E92                  | 5        | Ground | Battery voltage |

Is the inspection result normal?

YES >> GO TO 10.

NO >> GO TO 9.

## 9. DETECT MALFUNCTIONING PART

Check the following.

- Fuse block (J/B) connector E103
- 10 A fuse (No. 7)
- Harness for open or short between battery and stop lamp switch
- Harness for open or short between battery and ICC brake hold relay

>> Repair open circuit or short to ground in harness or connectors.

## 10. CHECK STOP LAMP SWITCH INPUT SIGNAL CIRCUIT FOR OPEN AND SHORT

1. Disconnect ECM harness connector.
2. Check the continuity between stop lamp switch harness connector and ECM harness connector.

| Stop lamp switch |          | ECM       |          | Continuity |
|------------------|----------|-----------|----------|------------|
| Connector        | Terminal | Connector | Terminal |            |
| E110             | 2        | M107      | 122      | Existed    |

3. Check the continuity between ICC brake hold relay harness connector and ECM harness connector.

| ICC brake hold relay |          | ECM       |          | Continuity |
|----------------------|----------|-----------|----------|------------|
| Connector            | Terminal | Connector | Terminal |            |
| E92                  | 3        | M107      | 122      | Existed    |

4. Also check harness for short to ground and short to power.

Is the inspection result normal?

YES >> GO TO 12.

NO >> GO TO 11.

## 11. DETECT MALFUNCTIONING PART

Check the following.

- Fuse block (J/B) connector E103, M2
- Harness for open or short between ECM and stop lamp switch
- Harness for open or short between ECM and ICC brake hold relay

# P1572 ICC BRAKE SWITCH

< DTC/CIRCUIT DIAGNOSIS >

[VQ37VHR FOR MEXICO]

>> Repair open circuit, short to ground or short to power in harness or connectors.

## 12.CHECK STOP LAMP SWITCH

Refer to [EC-904. "Component Inspection \(Stop Lamp Switch\)".](#)

Is the inspection result normal?

YES >> GO TO 13.

NO >> Replace stop lamp switch. Refer to [BR-18. "Exploded View".](#)

## 13.CHECK ICC BRAKE HOLD RELAY

Refer to [EC-905. "Component Inspection \(ICC Brake Hold Relay\)".](#)

Is the inspection result normal?

YES >> GO TO 14.

NO >> Replace ICC brake hold relay.

## 14.CHECK INTERMITTENT INCIDENT

Refer to [GI-44. "Intermittent Incident".](#)

>> INSPECTION END

### Component Inspection (ICC Brake Switch)

INFOID:000000007730038

#### 1.CHECK ICC BRAKE SWITCH-I

1. Turn ignition switch OFF.
2. Disconnect ICC brake switch harness connector.
3. Check the continuity between ICC brake switch terminals under the following conditions.

| Terminals | Condition   |                    | Continuity  |
|-----------|-------------|--------------------|-------------|
| 1 and 2   | Brake pedal | Fully released     | Existed     |
|           |             | Slightly depressed | Not existed |

Is the inspection result normal?

YES >> INSPECTION END

NO >> GO TO 2.

#### 2.CHECK ICC BRAKE SWITCH-II

1. Adjust ICC brake switch installation. Refer to [BR-19. "Inspection and Adjustment".](#)
2. Check the continuity between ICC brake switch terminals under the following conditions.

| Terminals | Condition   |                    | Continuity  |
|-----------|-------------|--------------------|-------------|
| 1 and 2   | Brake pedal | Fully released     | Existed     |
|           |             | Slightly depressed | Not existed |

Is the inspection result normal?

YES >> INSPECTION END

NO >> Replace ICC brake switch. Refer to [BR-18. "Exploded View".](#)

### Component Inspection (Stop Lamp Switch)

INFOID:000000007730039

#### 1.CHECK STOP LAMP SWITCH-I

1. Turn ignition switch OFF.
2. Disconnect stop lamp switch harness connector.
3. Check the continuity between stop lamp switch terminals under the following conditions.



# P1572 ICC BRAKE SWITCH

< DTC/CIRCUIT DIAGNOSIS >

[VQ37VHR FOR MEXICO]

| Terminals | Condition   |                    | Continuity  |
|-----------|-------------|--------------------|-------------|
| 1 and 2   | Brake pedal | Fully released     | Not existed |
|           |             | Slightly depressed | Existed     |

Is the inspection result normal?

- YES >> INSPECTION END
- NO >> GO TO 2.

## 2.CHECK STOP LAMP SWITCH-II

1. Adjust stop lamp switch installation. Refer to [BR-19. "Inspection and Adjustment"](#).
2. Check the continuity between stop lamp switch terminals under the following conditions.

| Terminals | Condition   |                    | Continuity  |
|-----------|-------------|--------------------|-------------|
| 1 and 2   | Brake pedal | Fully released     | Not existed |
|           |             | Slightly depressed | Existed     |

Is the inspection result normal?

- YES >> INSPECTION END
- NO >> Replace stop lamp switch. Refer to [BR-18. "Exploded View"](#).

## Component Inspection (ICC Brake Hold Relay)

INFOID:000000007730040

### 1.CHECK ICC BRAKE HOLD RELAY

1. Turn ignition switch OFF.
2. Remove ICC brake hold relay.
3. Check the continuity between ICC brake hold relay terminals under the following conditions.

| Terminals | Condition   | Continuity  |
|-----------|---|-------------|
| 3 and 5   | 12V direct current supply between terminals 1 and 2 | Existed     |
|           | No current supply                                   | Not existed |

Is the inspection result normal?

- YES >> INSPECTION END
- NO >> Replace ICC brake hold relay

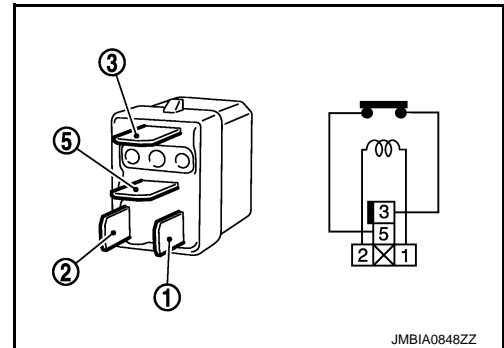

# P1574 ASCD VEHICLE SPEED SENSOR

< DTC/CIRCUIT DIAGNOSIS >

[VQ37VHR FOR MEXICO]

## P1574 ASCD VEHICLE SPEED SENSOR

### Description

INFOID:000000007730041

The ECM receives two vehicle speed signals via the CAN communication line. One is sent from “combination meter”, and the other is from TCM (Transmission control module). The ECM uses these signals for ASCD control. Refer to [EC-578, "AUTOMATIC SPEED CONTROL DEVICE \(ASCD\) : System Description"](#) for ASCD functions.

### DTC Logic

INFOID:000000007730042

#### DTC DETECTION LOGIC

##### NOTE:

- If DTC P1574 is displayed with DTC UXXXX, first perform the trouble diagnosis for DTC UXXXX.
- If DTC P1574 is displayed with DTC P0500, first perform the trouble diagnosis for DTC P0500. Refer to [EC-810, "DTC Logic"](#).
- If DTC P1574 is displayed with DTC P0605, first perform the trouble diagnosis for DTC P0605. Refer to [EC-819, "DTC Logic"](#).
- If DTC P1574 is displayed with DTC P0607, first perform the trouble diagnosis for DTC P0607. Refer to [EC-821, "DTC Logic"](#).

| DTC No. | Trouble diagnosis name    | DTC detecting condition   | Possible cause  |
|---------|---------------------------|---|---|
| P1574   | ASCD vehicle speed sensor | The difference between the two vehicle speed signals is out of the specified range. | <ul style="list-style-type: none"><li>• Harness or connectors<br/>(The CAN communication line is open or shorted.)</li><li>• Combination meter</li><li>• ABS actuator and electric unit (control unit)</li><li>• Wheel sensor</li><li>• TCM</li><li>• ECM</li></ul> |

#### DTC CONFIRMATION PROCEDURE

##### 1. PRECONDITIONING

If DTC Confirmation Procedure has been previously conducted, always perform the following procedure before conducting the next test.

1. Turn ignition switch OFF and wait at least 10 seconds.
2. Turn ignition switch ON.
3. Turn ignition switch OFF and wait at least 10 seconds.

>> GO TO 2.

##### 2. PERFORM DTC CONFIRMATION PROCEDURE

1. Start engine (VDC switch OFF).
2. Drive the vehicle at more than 40 km/h (25 MPH).

##### CAUTION:

**Always drive vehicle at a safe speed.**

##### NOTE:

**This procedure may be conducted with the drive wheels lifted in the shop or by driving the vehicle. If a road test is expected to be easier, it is unnecessary to lift the vehicle.**

3. Check DTC.

Is DTC detected?

- YES >> Go to [EC-906, "Diagnosis Procedure"](#).  
NO >> INSPECTION END

### Diagnosis Procedure

INFOID:000000007730043

##### 1. CHECK DTC WITH TCM

Check DTC with TCM. Refer to [TM-59, "Diagnosis Description"](#).

Is the inspection result normal?

# P1574 ASCD VEHICLE SPEED SENSOR

[VQ37VHR FOR MEXICO]

< DTC/CIRCUIT DIAGNOSIS >

- YES >> GO TO 2.
- NO >> Perform trouble shooting relevant to DTC indicated.

A

## 2.CHECK DTC WITH “ABS ACTUATOR AND ELECTRIC UNIT (CONTROL UNIT)”

Refer to [BRC-40. "CONSULT Function"](#).

Is the inspection result normal?

- YES >> GO TO 3.
- NO >> Repair or replace.

EC

## 3.CHECK DTC WITH “COMBINATION METER”

Refer to [MWI-31. "CONSULT Function"](#).

C

>> INSPECTION END

D

E

F

G

H

I

J

K

L

M

N

O

P

# P1574 ICC VEHICLE SPEED SENSOR

< DTC/CIRCUIT DIAGNOSIS >

[VQ37VHR FOR MEXICO]

## P1574 ICC VEHICLE SPEED SENSOR

### Description

INFOID:000000007730044

The ECM receives two vehicle speed signals via CAN communication line. One is sent from "combination meter", and the other is from TCM (Transmission control module). The ECM uses these signals for ICC control. Refer to [CCS-13, "System Description"](#) for ICC functions.

### DTC Logic

INFOID:000000007730045

#### DTC DETECTION LOGIC

##### NOTE:

- If DTC P1574 is displayed with DTC UXXXX, first perform the trouble diagnosis for DTC UXXXX.
- If DTC P1574 is displayed with DTC P0500, first perform the trouble diagnosis for DTC P0500. Refer to [EC-810, "DTC Logic"](#).
- If DTC P1574 is displayed with DTC P0605, first perform the trouble diagnosis for DTC P0605. Refer to [EC-819, "DTC Logic"](#).
- If DTC P1574 is displayed with DTC P0607, first perform the trouble diagnosis for DTC P0607. Refer to [EC-821, "DTC Logic"](#).

| DTC No. | Trouble diagnosis name   | DTC detecting condition   | Possible cause  |
|---------|--------------------------|---|---|
| P1574   | ICC vehicle speed sensor | The difference between the two vehicle speed signals is out of the specified range. | <ul style="list-style-type: none"><li>• Harness or connectors<br/>(The CAN communication line is open or shorted.)</li><li>• Combination meter</li><li>• ABS actuator and electric unit (control unit)</li><li>• Wheel sensor</li><li>• TCM</li><li>• ECM</li></ul> |

#### DTC CONFIRMATION PROCEDURE

##### 1. PRECONDITIONING

If DTC Confirmation Procedure has been previously conducted, always perform the following procedure before conducting the next test.

1. Turn ignition switch OFF and wait at least 10 seconds.
2. Turn ignition switch ON.
3. Turn ignition switch OFF and wait at least 10 seconds.

>> GO TO 2.

##### 2. PERFORM DTC CONFIRMATION PROCEDURE

1. Start engine (VDC switch OFF).
2. Drive the vehicle at more than 40 km/h (25 MPH).

##### CAUTION:

**Always drive vehicle at a safe speed.**

##### NOTE:

**This procedure may be conducted with the drive wheels lifted in the shop or by driving the vehicle. If a road test is expected to be easier, it is unnecessary to lift the vehicle.**

3. Check DTC.

Is DTC detected?

- YES >> Go to [EC-908, "Diagnosis Procedure"](#).  
NO >> INSPECTION END

### Diagnosis Procedure

INFOID:000000007730046

##### 1. CHECK DTC WITH TCM

Check DTC with TCM. Refer to [TM-59, "Diagnosis Description"](#).

Is the inspection result normal?

- YES >> GO TO 2.

# P1574 ICC VEHICLE SPEED SENSOR

[VQ37VHR FOR MEXICO]

< DTC/CIRCUIT DIAGNOSIS >

NO >> Perform trouble shooting relevant to DTC indicated.

## 2.CHECK DTC WITH “ABS ACTUATOR AND ELECTRIC UNIT (CONTROL UNIT)”

Refer to [BRC-40, "CONSULT Function"](#).

Is the inspection result normal?

YES >> GO TO 3.

NO >> Repair or replace.

## 3.CHECK DTC WITH “COMBINATION METER”

Check combination meter function.

Refer to [MWI-31, "CONSULT Function"](#).

>> INSPECTION END

A

EC

C

D

E

F

G

H

I

J

K

L

M

N

O

P

# P1606 VVEL CONTROL MODULE

< DTC/CIRCUIT DIAGNOSIS >

[VQ37VHR FOR MEXICO]

## P1606 VVEL CONTROL MODULE

### DTC Logic

INFOID:000000007730047

### DTC DETECTION LOGIC

| DTC No. | Trouble diagnosis name | DTC detecting condition   | Possible cause  |
|---------|------------------------|---|---|
| P1606   | VVEL control module    | <ul style="list-style-type: none"><li>• VVEL control module calculation function is malfunctioning.</li><li>• VVEL EEPROM system is malfunctioning.</li></ul> | <ul style="list-style-type: none"><li>• VVEL control module</li></ul> |

### DTC CONFIRMATION PROCEDURE

#### 1. PRECONDITIONING

If DTC Confirmation Procedure has been previously conducted, always perform the following procedure before conducting the next test.

1. Turn ignition switch OFF and wait at least 10 seconds.
2. Turn ignition switch ON.
3. Turn ignition switch OFF and wait at least 10 seconds.

#### TESTING CONDITION:

**Before performing the following procedure, confirm that battery voltage is more than 10 V at idle.**

>> GO TO 2.

#### 2. PERFORM DTC CONFIRMATION PROCEDURE

1. Turn ignition switch ON and wait at least 1 second.
2. Check DTC.

#### Is DTC detected?

- YES >> Go to [EC-910, "Diagnosis Procedure"](#).  
NO >> INSPECTION END

### Diagnosis Procedure

INFOID:000000007730048

#### 1. PERFORM DTC CONFIRMATION PROCEDURE

1. Turn ignition switch ON.
2. Erase DTC.
3. Perform DTC Confirmation Procedure.  
See [EC-910, "DTC Logic"](#).

#### Is the DTC P1606 displayed again?

- YES >> GO TO 2.  
NO >> INSPECTION END

#### 2. REPLACE VVEL CONTROL MODULE

1. Replace VVEL control module.
2. Go to [EC-654, "Work Procedure"](#).

>> INSPECTION END

# P1607 VVEL CONTROL MODULE

< DTC/CIRCUIT DIAGNOSIS >

[VQ37VHR FOR MEXICO]

## P1607 VVEL CONTROL MODULE

### DTC Logic

INFOID:000000007730049

### DTC DETECTION LOGIC

| DTC No. | Trouble diagnosis name      | DTC detecting condition  | Possible cause        |
|---------|-----------------------------|--|-----------------------|
| P1607   | VVEL control module circuit | • The internal circuit of the VVEL control module is malfunctioning. | • VVEL control module |

### DTC CONFIRMATION PROCEDURE

#### 1. PRECONDITIONING

If DTC Confirmation Procedure has been previously conducted, always perform the following procedure before conducting the next test.

1. Turn ignition switch OFF and wait at least 10 seconds.
2. Turn ignition switch ON.
3. Turn ignition switch OFF and wait at least 10 seconds.

#### TESTING CONDITION:

Before performing the following procedure, confirm that battery voltage is more than 10 V at idle.

>> GO TO 2.

#### 2. PERFORM DTC CONFIRMATION PROCEDURE

1. Start engine and let it idle for at least 1 second.
2. Check DTC.

#### Is DTC detected?

- YES >> Go to [EC-911, "Diagnosis Procedure"](#).  
NO >> INSPECTION END

### Diagnosis Procedure

INFOID:000000007730050

#### 1. PERFORM DTC CONFIRMATION PROCEDURE

1. Turn ignition switch ON.
2. Erase DTC.
3. Perform DTC Confirmation Procedure.  
See [EC-911, "DTC Logic"](#).

#### Is the DTC P1607 displayed again?

- YES >> GO TO 2.  
NO >> INSPECTION END

#### 2. REPLACE VVEL CONTROL MODULE

1. Replace VVEL control module.
2. Go to [EC-654, "Work Procedure"](#).

>> INSPECTION END

# P1608 VVEL SENSOR POWER SUPPLY

< DTC/CIRCUIT DIAGNOSIS >

[VQ37VHR FOR MEXICO]

## P1608 VVEL SENSOR POWER SUPPLY

### DTC Logic

INFOID:000000007730051

### DTC DETECTION LOGIC

| DTC No. | Trouble diagnosis name           | DTC detecting condition  | Possible cause   |
|---------|----------------------------------|--|--|
| P1608   | VVEL sensor power supply circuit | VVEL control module detects a voltage of power source for sensor is excessively low or high. | <ul style="list-style-type: none"><li>• Harness or connectors (VVEL control shaft position sensor power supply circuit is open or shorted.)</li><li>• VVEL control shaft position sensor</li><li>• VVEL control module</li></ul> |

### DTC CONFIRMATION PROCEDURE

#### 1. PRECONDITIONING

If DTC Confirmation Procedure has been previously conducted, always perform the following procedure before conducting the next test.

1. Turn ignition switch OFF and wait at least 10 seconds.
2. Turn ignition switch ON.
3. Turn ignition switch OFF and wait at least 10 seconds.

#### TESTING CONDITION:

Before performing the following procedure, confirm that battery voltage is more than 10 V at idle.

>> GO TO 2.

#### 2. PERFORM DTC CONFIRMATION PROCEDURE

1. Turn ignition switch ON and wait at least 1 second.
2. Check DTC.

#### Is DTC detected?

- YES >> Go to [EC-912. "Diagnosis Procedure"](#).  
NO >> INSPECTION END

### Diagnosis Procedure

INFOID:000000007730052

#### 1. CHECK GROUND CONNECTION

1. Turn ignition switch OFF.
2. Check ground connection M95. Refer to Ground Inspection in [GI-47. "Circuit Inspection"](#).

#### Is the inspection result normal?

- YES >> GO TO 2.  
NO >> Repair or replace ground connection.

#### 2. CHECK VVEL CONTROL SHAFT POSITION SENSOR POWER SUPPLY CIRCUIT

1. Disconnect VVEL control shaft position sensor harness connector.
2. Turn ignition switch ON.
3. Check the voltage between VVEL control shaft position sensor harness connector and ground.

| VVEL control shaft position sensor |           |          | Ground | Voltage (V) |
|------------------------------------|-----------|----------|--------|-------------|
| Bank                               | Connector | Terminal |        |             |
| 1                                  | F46       | 3        | Ground | Approx. 5   |
|                                    |           | 6        |        |             |
| 2                                  | F47       | 3        |        |             |
|                                    |           | 6        |        |             |

#### Is the inspection result normal?

- YES >> GO TO 7.  
NO >> GO TO 3.



# P1608 VVEL SENSOR POWER SUPPLY

< DTC/CIRCUIT DIAGNOSIS >

[VQ37VHR FOR MEXICO]

## 3. CHECK VVEL CONTROL SHAFT POSITION SENSOR POWER SUPPLY CIRCUIT FOR OPEN AND SHORT

1. Turn ignition switch OFF.
2. Disconnect VVEL control module harness connector.
3. Check the continuity between VVEL control shaft position sensor harness connector and VVEL control module harness connector.

| VVEL control shaft position sensor |           |          | VVEL control module |          | Continuity |
|------------------------------------|-----------|----------|---------------------|----------|------------|
| Bank                               | Connector | Terminal | Connector           | Terminal |            |
| 1                                  | F46       | 3        | E15                 | 9        | Existed    |
|                                    |           | 6        |                     | 22       |            |
| 2                                  | F47       | 3        |                     | 7        |            |
|                                    |           | 6        |                     | 20       |            |

4. Also check harness for short to ground and power.

Is the inspection result normal?

- YES >> GO TO 5.  
NO >> GO TO 4.

## 4. DETECT MALFUNCTIONING PART

Check the following.

- Harness connectors E20, F40
- Harness for open or short between VVEL control shaft position sensor and VVEL control module

>> Repair open circuit, short to ground or short to power in harness or connectors.

## 5. CHECK INTERMITTENT INCIDENT

Refer to [GI-44, "Intermittent Incident"](#).

Is the inspection result normal?

- YES >> GO TO 6.  
NO >> Repair or replace.

## 6. REPLACE VVEL CONTROL MODULE

1. Replace VVEL control module.
2. Go to [EC-654, "Work Procedure"](#).

>> INSPECTION END

## 7. CHECK INTERMITTENT INCIDENT

Refer to [GI-44, "Intermittent Incident"](#).

Is the inspection result normal?

- YES >> GO TO 8.  
NO >> Repair or replace.

## 8. REPLACE VVEL ACTUATOR SUB ASSEMBLY

1. Replace VVEL actuator sub assembly.
2. Go to [EC-913, "Special Repair Requirement"](#).

>> INSPECTION END

## Special Repair Requirement

INFOID:000000007730053

## 1. PERFORM VVEL CONTROL SHAFT POSITION SENSOR ADJUSTMENT

Refer to [EC-660, "Work Procedure"](#).

## P1608 VVEL SENSOR POWER SUPPLY

< DTC/CIRCUIT DIAGNOSIS >

[VQ37VHR FOR MEXICO]

---

>> GO TO 2.

### 2.PERFORM IDLE AIR VOLUME LEARNING

---

Refer to [EC-658, "Work Procedure"](#).

>> END

# P1805 BRAKE SWITCH

< DTC/CIRCUIT DIAGNOSIS >

[VQ37VHR FOR MEXICO]

## P1805 BRAKE SWITCH

### DTC Logic

INFOID:000000007730054

### DTC DETECTION LOGIC

| DTC No. | Trouble diagnosis name | DTC detecting condition   | Possible cause   |
|---------|------------------------|---|--|
| P1805   | Brake switch           | A brake switch signal is not sent to ECM for extremely long time while the vehicle is being driven. | <ul style="list-style-type: none"> <li>Harness or connectors (Stop lamp switch circuit is open or shorted.)</li> <li>Stop lamp switch</li> </ul> |

### DTC CONFIRMATION PROCEDURE

#### 1. PERFORM DTC CONFIRMATION PROCEDURE

- Turn ignition switch ON.
- Fully depress the brake pedal for at least 5 seconds.
- Erase the DTC.
- Check 1st trip DTC.

#### Is 1st trip DTC detected?

- YES >> Go to [EC-915, "Diagnosis Procedure"](#).
- NO >> INSPECTION END

### Diagnosis Procedure

INFOID:000000007730055

#### 1. CHECK STOP LAMP SWITCH CIRCUIT

- Turn ignition switch OFF.
- Check the stop lamp when depressing and releasing the brake pedal.

| Brake pedal        | Stop lamp       |
|--------------------|-----------------|
| Fully released     | Not illuminated |
| Slightly depressed | Illuminated     |

#### Is the inspection result normal?

- YES >> GO TO 4.
- NO >> GO TO 2.

#### 2. CHECK STOP LAMP SWITCH POWER SUPPLY CIRCUIT

- Disconnect stop lamp switch harness connector.
- Check the voltage between stop lamp switch harness connector and ground.

| Stop lamp switch |          | Ground | Voltage         |
|------------------|----------|--------|-----------------|
| Connector        | Terminal |        |                 |
| E110             | 1        | Ground | Battery voltage |

#### Is the inspection result normal?

- YES >> GO TO 4.
- NO >> GO TO 3.

#### 3. DETECT MALFUNCTIONING PART

Check the following.

- Fuse block (J/B) connector E103
- 10 A fuse (No. 7)
- Harness for open or short between stop lamp switch and battery

>> Repair open circuit, short to ground or short to power in harness or connectors.

#### 4. CHECK STOP LAMP SWITCH INPUT SIGNAL CIRCUIT FOR OPEN AND SHORT

# P1805 BRAKE SWITCH

[VQ37VHR FOR MEXICO]

## < DTC/CIRCUIT DIAGNOSIS >

1. Disconnect stop lamp switch harness connector.
2. Disconnect ECM harness connector.
3. Check the continuity between stop lamp switch harness connector and ECM harness connector.

| Stop lamp switch |          | ECM       |          | Continuity |
|------------------|----------|-----------|----------|------------|
| Connector        | Terminal | Connector | Terminal |            |
| E110             | 2        | M107      | 122      | Existed    |

4. Also check harness for short to ground and short to power.

### Is the inspection result normal?

YES >> GO TO 6.

NO >> GO TO 5.

## 5. DETECT MALFUNCTIONING PART

Check the following.

- Fuse block (J/B) connector E103, M2
- Harness for open or short between ECM and stop lamp switch

>> Repair open circuit, short to ground or short to power in harness or connectors.

## 6. CHECK STOP LAMP SWITCH

Refer to [EC-916, "Component Inspection \(Stop Lamp Switch\)"](#).

### Is the inspection result normal?

YES >> GO TO 7.

NO >> Replace stop lamp switch. Refer to [BR-18, "Exploded View"](#).

## 7. CHECK INTERMITTENT INCIDENT

Refer to [GI-44, "Intermittent Incident"](#).

>> INSPECTION END

## Component Inspection (Stop Lamp Switch)

INFOID:000000007730056

### 1. CHECK STOP LAMP SWITCH-I

1. Turn ignition switch OFF.
2. Disconnect stop lamp switch harness connector.
3. Check the continuity between stop lamp switch terminals under the following conditions.

| Terminals | Condition   |                    | Continuity  |
|-----------|-------------|--------------------|-------------|
| 1 and 2   | Brake pedal | Fully released     | Not existed |
|           |             | Slightly depressed | Existed     |

### Is the inspection result normal?

YES >> INSPECTION END

NO >> GO TO 2.

### 2. CHECK STOP LAMP SWITCH-II

1. Adjust stop lamp switch installation. Refer to [BR-19, "Inspection and Adjustment"](#).
2. Check the continuity between stop lamp switch terminals under the following conditions.

| Terminals | Condition   |                    | Continuity  |
|-----------|-------------|--------------------|-------------|
| 1 and 2   | Brake pedal | Fully released     | Not existed |
|           |             | Slightly depressed | Existed     |

### Is the inspection result normal?

YES >> INSPECTION END

# P1805 BRAKE SWITCH

< DTC/CIRCUIT DIAGNOSIS >

[VQ37VHR FOR MEXICO]

NO >> Replace stop lamp switch. Refer to [BR-18. "Exploded View"](#).

A

EC

C

D

E

F

G

H

I

J

K

L

M

N

O

P

# P2122, P2123 APP SENSOR

< DTC/CIRCUIT DIAGNOSIS >

[VQ37VHR FOR MEXICO]

## P2122, P2123 APP SENSOR

### DTC Logic

INFOID:000000007730057

#### DTC DETECTION LOGIC

##### NOTE:

If DTC P2122 or P2123 is displayed with DTC P0643, first perform the trouble diagnosis for DTC P0643. Refer to [EC-822, "DTC Logic"](#).

| DTC No. | Trouble diagnosis name                                 | DTC detecting condition   | Possible cause   |
|---------|--|---|--|
| P2122   | Accelerator pedal position sensor 1 circuit low input  | An excessively low voltage from the APP sensor 1 is sent to ECM.  | • Harness or connectors (APP sensor 1 circuit is open or shorted.) |
| P2123   | Accelerator pedal position sensor 1 circuit high input | An excessively high voltage from the APP sensor 1 is sent to ECM. | • Accelerator pedal position sensor (APP sensor 1)                 |

#### DTC CONFIRMATION PROCEDURE

##### 1. PRECONDITIONING

If DTC Confirmation Procedure has been previously conducted, always perform the following procedure before conducting the next test.

1. Turn ignition switch OFF and wait at least 10 seconds.
2. Turn ignition switch ON.
3. Turn ignition switch OFF and wait at least 10 seconds.

##### TESTING CONDITION:

Before performing the following procedure, confirm that battery voltage is more than 10 V at idle.

>> GO TO 2.

##### 2. PERFORM DTC CONFIRMATION PROCEDURE

1. Start engine and let it idle for 1 second.
2. Check DTC.

##### Is DTC detected?

- YES >> Go to [EC-918, "Diagnosis Procedure"](#).  
NO >> INSPECTION END

#### Diagnosis Procedure

INFOID:000000007730058

##### 1. CHECK GROUND CONNECTION

1. Turn ignition switch OFF.
2. Check ground connection M95. Refer to Ground Inspection in [GI-47, "Circuit Inspection"](#).

##### Is the inspection result normal?

- YES >> GO TO 2.  
NO >> Repair or replace ground connection.

##### 2. CHECK APP SENSOR 1 POWER SUPPLY CIRCUIT

1. Disconnect accelerator pedal position (APP) sensor harness connector.
2. Turn ignition switch ON.
3. Check the voltage between APP sensor harness connector and ground.

| APP sensor |          | Ground | Voltage (V) |
|------------|----------|--------|-------------|
| Connector  | Terminal |        |             |
| M153*1     | 6*1      | Ground | Approx. 5   |
| M9*2       | 5*2      |        |             |

\*1: With ICC

\*2: Without ICC

##### Is the inspection result normal?

# P2122, P2123 APP SENSOR

[VQ37VHR FOR MEXICO]

## < DTC/CIRCUIT DIAGNOSIS >

- YES >> GO TO 4.
- NO >> GO TO 3.

### 3. DETECT MALFUNCTIONING PART

Check the following.

- Harness connectors M6, E106
- Harness for open or short between ECM and accelerator pedal position sensor

>> Repair open circuit, short to ground or short to power in harness or connectors.

### 4. CHECK APP SENSOR 1 GROUND CIRCUIT FOR OPEN AND SHORT

1. Turn ignition switch OFF.
2. Disconnect ECM harness connector.
3. Check the continuity between APP sensor harness connector and ECM harness connector.

| APP sensor         |                 | ECM       |          | Continuity |
|--------------------|-----------------|-----------|----------|------------|
| Connector          | Terminal        | Connector | Terminal |            |
| M153 <sup>*1</sup> | 5 <sup>*1</sup> | M107      | 100      | Existed    |
| M9 <sup>*2</sup>   | 4 <sup>*2</sup> |           |          |            |

\*1: With ICC

\*2: Without ICC

4. Also check harness for short to ground and short to power.

Is the inspection result normal?

- YES >> GO TO 6.
- NO >> GO TO 5 (With ICC).
- NO >> Repair open circuit, short to ground or short to power in harness or connectors (Without ICC).

### 5. DETECT MALFUNCTIONING PART

Check the following.

- Harness connectors M150, M151
- Harness for open or short between ECM and accelerator pedal position sensor

>> Repair open circuit, short to ground or short to power in harness or connectors.

### 6. CHECK APP SENSOR INPUT SIGNAL CIRCUIT FOR OPEN AND SHORT

1. Check the continuity between APP sensor harness connector and ECM harness connector.

| APP sensor         |                 | ECM       |          | Continuity |
|--------------------|-----------------|-----------|----------|------------|
| Connector          | Terminal        | Connector | Terminal |            |
| M153 <sup>*1</sup> | 4 <sup>*1</sup> | M107      | 97       | Existed    |
| M9 <sup>*2</sup>   | 3 <sup>*2</sup> |           |          |            |

\*1: With ICC

\*2: Without ICC

2. Also check harness for short to ground and short to power.

Is the inspection result normal?

- YES >> GO TO 8.
- NO >> GO TO 7 (With ICC).
- NO >> Repair open circuit, short to ground or short to power in harness or connectors (Without ICC).

### 7. DETECT MALFUNCTIONING PART

Check the following.

- Harness connectors M150, M151
- Harness for open or short between ECM and accelerator pedal position sensor

>> Repair open circuit, short to ground or short to power in harness or connectors.

< DTC/CIRCUIT DIAGNOSIS >

**8.CHECK APP SENSOR**

Refer to [EC-920, "Component Inspection"](#).

Is the inspection result normal?

- YES >> GO TO 10.
- NO >> GO TO 9.

**9.REPLACE ACCELERATOR PEDAL ASSEMBLY**

1. Replace accelerator pedal assembly.
2. Go to [EC-920, "Special Repair Requirement"](#).

>> INSPECTION END

**10.CHECK INTERMITTENT INCIDENT**

Refer to [GI-44, "Intermittent Incident"](#).

>> INSPECTION END

**Component Inspection**

INFOID:000000007730059

**1.CHECK ACCELERATOR PEDAL POSITION SENSOR**

1. Turn ignition switch OFF.
2. Reconnect all harness connectors disconnected.
3. Turn ignition switch ON.
4. Check the voltage ECM harness connector terminals as per the following.

| ECM       |                   |          | Condition       | Voltage (V) |
|-----------|-------------------|----------|-----------------|-------------|
| Connector | +                 | -        |                 |             |
|           | Terminal          | Terminal |                 |             |
| M107      | 97 (APP sensor 1) | 100      | Fully released  | 0.45 - 1.0  |
|           |                   |          | Fully depressed | 4.2 - 4.8   |
|           | 98 (APP sensor 2) | 104      | Fully released  | 0.22 - 0.50 |
|           |                   |          | Fully depressed | 2.1 - 2.5   |

Is the inspection result normal?

- YES >> INSPECTION END
- NO >> GO TO 2.

**2.REPLACE ACCELERATOR PEDAL ASSEMBLY**

1. Replace accelerator pedal assembly.
2. Go to [EC-920, "Special Repair Requirement"](#).

>> INSPECTION END

**Special Repair Requirement**

INFOID:000000007730060

**1.PERFORM ACCELERATOR PEDAL RELEASED POSITION LEARNING**

Refer to [EC-656, "Work Procedure"](#).

>> GO TO 2.

**2.PERFORM THROTTLE VALVE CLOSED POSITION LEARNING**

Refer to [EC-657, "Work Procedure"](#).

>> GO TO 3.



# P2122, P2123 APP SENSOR

< DTC/CIRCUIT DIAGNOSIS >

[VQ37VHR FOR MEXICO]

## 3.PERFORM IDLE AIR VOLUME LEARNING

Refer to [EC-658. "Work Procedure"](#).

>> END

A

EC

C

D

E

F

G

H

I

J

K

L

M

N

O

P

# P2127, P2128 APP SENSOR

< DTC/CIRCUIT DIAGNOSIS >

[VQ37VHR FOR MEXICO]

## P2127, P2128 APP SENSOR

### DTC Logic

INFOID:000000007730061

### DTC DETECTION LOGIC

| DTC No. | Trouble diagnosis name                                 | DTC detecting condition   | Possible cause  |
|---------|--|---|---|
| P2127   | Accelerator pedal position sensor 2 circuit low input  | An excessively low voltage from the APP sensor 2 is sent to ECM.  | <ul style="list-style-type: none"><li>• Harness or connectors (APP sensor 2 circuit is open or shorted.) [CKP sensor (POS) circuit is shorted.] [CMP sensor (PHASE) (bank 2) circuit is open or shorted.] (Battery current sensor circuit is open or shorted.) (EVAP control system pressure sensor circuit is shorted.) (Refrigerant pressure sensor circuit is shorted.)</li><li>• Accelerator pedal position sensor (APP sensor 2)</li><li>• Crankshaft position sensor (POS)</li><li>• Camshaft position sensor (PHASE) (bank 2)</li><li>• Battery current sensor</li><li>• EVAP control system pressure sensor</li><li>• Refrigerant pressure sensor</li></ul> |
| P2128   | Accelerator pedal position sensor 2 circuit high input | An excessively high voltage from the APP sensor 2 is sent to ECM. |   |

### DTC CONFIRMATION PROCEDURE

#### 1. PRECONDITIONING

If DTC Confirmation Procedure has been previously conducted, always perform the following procedure before conducting the next test.

1. Turn ignition switch OFF and wait at least 10 seconds.
2. Turn ignition switch ON.
3. Turn ignition switch OFF and wait at least 10 seconds.

#### TESTING CONDITION:

**Before performing the following procedure, confirm that battery voltage is more than 10 V at idle.**

>> GO TO 2.

#### 2. PERFORM DTC CONFIRMATION PROCEDURE

1. Start engine and let it idle for 1 second.
2. Check DTC.

Is DTC detected?

- YES >> Go to [EC-922, "Diagnosis Procedure"](#).  
NO >> INSPECTION END

### Diagnosis Procedure

INFOID:000000007730062

#### 1. CHECK GROUND CONNECTION

1. Turn ignition switch OFF.
2. Check ground connection M95. Refer to Ground Inspection in [GI-47, "Circuit Inspection"](#).

Is the inspection result normal?

- YES >> GO TO 2.  
NO >> Repair or replace ground connection.

#### 2. CHECK APP SENSOR 2 POWER SUPPLY CIRCUIT-I

1. Disconnect accelerator pedal position (APP) sensor harness connector.
2. Turn ignition switch ON.
3. Check the voltage between APP sensor harness connector and ground.

# P2127, P2128 APP SENSOR

< DTC/CIRCUIT DIAGNOSIS >

[VQ37VHR FOR MEXICO]

| APP sensor                             |                                    | Ground | Voltage (Approx.) |
|--|------------------------------------|--------|-------------------|
| Connector                              | Terminal                           |        |                   |
| M153 <sup>*1</sup><br>M9 <sup>*2</sup> | 3 <sup>*1</sup><br>6 <sup>*2</sup> | Ground | 5 V               |

\*1: With ICC

\*2: Without ICC

Is the inspection result normal?

YES >> GO TO 7.

NO >> GO TO 3.

## 3.CHECK APP SENSOR 2 POWER SUPPLY CIRCUIT-II

1. Turn ignition switch OFF.
2. Disconnect ECM harness connector.
3. Check the continuity between APP sensor harness connector and ECM harness connector.

| APP sensor                             |                                    | ECM       |          | Continuity |
|--|------------------------------------|-----------|----------|------------|
| Connector                              | Terminal                           | Connector | Terminal |            |
| M153 <sup>*1</sup><br>M9 <sup>*2</sup> | 3 <sup>*1</sup><br>6 <sup>*2</sup> | M107      | 103      | Existed    |

\*1: With ICC

\*2: Without ICC

Is the inspection result normal?

YES >> GO TO 5.

NO >> GO TO 4 (With ICC).

NO >> Repair open circuit, short to ground or short to power in harness or connectors (Without ICC).

## 4.DETECT MALFUNCTIONING PART

Check the following.

- Harness connectors M150, M151
- Harness for open or short between ECM and accelerator pedal position sensor

>> Repair open circuit, short to ground or short to power in harness or connectors.

## 5.CHECK SENSOR POWER SUPPLY CIRCUIT

Check harness for short to power and short to ground, between the following terminals.

| ECM       |          | Sensor                              |  |                                    |
|-----------|----------|-------------------------------------|--|------------------------------------|
| Connector | Terminal | Name                                | Connector                              | Terminal                           |
| F101      | 46       | CKP sensor (POS)                    | F2                                     | 1                                  |
| F102      | 64       | CMP sensor (PHASE) (bank 2)         | F18                                    | 1                                  |
|           |          | Battery current sensor              | E21                                    |                                    |
| M107      | 103      | APP sensor                          | M153 <sup>*1</sup><br>M9 <sup>*2</sup> | 3 <sup>*1</sup><br>6 <sup>*2</sup> |
|           | 107      | EVAP control system pressure sensor | B73                                    | 3                                  |
|           |          | Refrigerant pressure sensor         | E77                                    | 3                                  |

\*1: With ICC

\*2: Without ICC

Is the inspection result normal?

YES >> GO TO 6.

NO >> Repair short to ground or short to power in harness or connectors.

< DTC/CIRCUIT DIAGNOSIS >

**6. CHECK COMPONENTS**

Check the following.

- Crankshaft position sensor (POS) (Refer to [EC-781, "Component Inspection"](#).)
- Camshaft position sensor (PHASE) (bank 2) (Refer to [EC-786, "Component Inspection"](#).)
- Battery current sensor (Refer to [EC-870, "Component Inspection"](#).)
- Refrigerant pressure sensor (Refer to [EC-967, "Diagnosis Procedure"](#).)

Is the inspection result normal?

- YES >> GO TO 13.  
 NO >> Replace malfunctioning component.

**7. CHECK APP SENSOR 2 GROUND CIRCUIT FOR OPEN AND SHORT**

1. Turn ignition switch OFF.
2. Disconnect ECM harness connector.
3. Check the continuity between APP sensor harness connector and ECM harness connector.

| APP sensor     |          | ECM       |          | Continuity |
|----------------|----------|-----------|----------|------------|
| Connector      | Terminal | Connector | Terminal |            |
| M153*1<br>M9*2 | 2        | M107      | 104      | Existed    |

\*1: With ICC  
 \*2: Without ICC

4. Also check harness for short to ground and short to power.

Is the inspection result normal?

- YES >> GO TO 9.  
 NO >> GO TO 8 (With ICC).  
 NO >> Repair open circuit, short to ground or short to power in harness or connectors (Without ICC).

**8. DETECT MALFUNCTIONING PART**

Check the following.

- Harness connectors M150, M151
- Harness for open or short between ECM and accelerator pedal position sensor

>> Repair open circuit, short to ground or short to power in harness or connectors.

**9. CHECK APP SENSOR 2 INPUT SIGNAL CIRCUIT FOR OPEN AND SHORT**

1. Check the continuity between APP sensor harness connector and ECM harness connector.

| APP sensor     |          | ECM       |          | Continuity |
|----------------|----------|-----------|----------|------------|
| Connector      | Terminal | Connector | Terminal |            |
| M153*1<br>M9*2 | 1        | M107      | 98       | Existed    |

\*1: With ICC  
 \*2: Without ICC

2. Also check harness for short to ground and short to power.

Is the inspection result normal?

- YES >> GO TO 11.  
 NO >> GO TO 10 (With ICC).  
 NO >> Repair open circuit, short to ground or short to power in harness or connectors (Without ICC).

**10. DETECT MALFUNCTIONING PART**

Check the following.

- Harness connectors M150, M151
- Harness for open or short between ECM and accelerator pedal position sensor

# P2127, P2128 APP SENSOR

< DTC/CIRCUIT DIAGNOSIS >

[VQ37VHR FOR MEXICO]

>> Repair open circuit, short to ground or short to power in harness or connectors.

## 11. CHECK APP SENSOR

Refer to [EC-925, "Component Inspection"](#).

Is the inspection result normal?

YES >> GO TO 13.

NO >> GO TO 12.

## 12. REPLACE ACCELERATOR PEDAL ASSEMBLY

1. Replace accelerator pedal assembly.
2. Go to [EC-925, "Special Repair Requirement"](#).

>> INSPECTION END

## 13. CHECK INTERMITTENT INCIDENT

Refer to [GI-44, "Intermittent Incident"](#).

>> INSPECTION END

## Component Inspection

INFOID:000000007730063

### 1. CHECK ACCELERATOR PEDAL POSITION SENSOR

1. Turn ignition switch OFF.
2. Reconnect all harness connectors disconnected.
3. Turn ignition switch ON.
4. Check the voltage ECM harness connector terminals as per the following.

| ECM       |                   |          | Condition       | Voltage (V) |
|-----------|-------------------|----------|-----------------|-------------|
| Connector | +                 | -        |                 |             |
|           | Terminal          | Terminal |                 |             |
| M107      | 97 (APP sensor 1) | 100      | Fully released  | 0.45 - 1.0  |
|           |                   |          | Fully depressed | 4.2 - 4.8   |
|           | 98 (APP sensor 2) | 104      | Fully released  | 0.22 - 0.50 |
|           |                   |          | Fully depressed | 2.1 - 2.5   |

Is the inspection result normal?

YES >> INSPECTION END

NO >> GO TO 2.

### 2. REPLACE ACCELERATOR PEDAL ASSEMBLY

1. Replace accelerator pedal assembly.
2. Go to [EC-920, "Special Repair Requirement"](#).

>> INSPECTION END

## Special Repair Requirement

INFOID:000000007730064

### 1. PERFORM ACCELERATOR PEDAL RELEASED POSITION LEARNING

Refer to [EC-656, "Work Procedure"](#).

>> GO TO 2.

### 2. PERFORM THROTTLE VALVE CLOSED POSITION LEARNING

Refer to [EC-657, "Work Procedure"](#).

## P2127, P2128 APP SENSOR

< DTC/CIRCUIT DIAGNOSIS >

[VQ37VHR FOR MEXICO]

---

>> GO TO 3.

### 3.PERFORM IDLE AIR VOLUME LEARNING

---

Refer to [EC-658, "Work Procedure"](#).

>> END

P2138 APP SENSOR

DTC Logic

INFOID:000000007730065

DTC DETECTION LOGIC

NOTE:

If DTC P2138 is displayed with DTC P0643, first perform the trouble diagnosis for DTC P0643. Refer to [EC-822, "DTC Logic"](#).

| DTC No. | Trouble diagnosis name                                      | DTC detecting condition   | Possible cause  |
|---------|---|---|---|
| P2138   | Accelerator pedal position sensor circuit range/performance | Rationally incorrect voltage is sent to ECM compared with the signals from APP sensor 1 and APP sensor 2. | <ul style="list-style-type: none"> <li>• Harness or connectors (APP sensor 2 circuit is open or shorted.) [CKP sensor (POS) circuit is shorted.] [CMP sensor (PHASE) (bank 2) circuit is open or shorted.] (Battery current sensor circuit is open or shorted.) (EVAP control system pressure sensor circuit is shorted.) (Refrigerant pressure sensor circuit is shorted.)</li> <li>• Accelerator pedal position sensor (APP sensor 2)</li> <li>• Crankshaft position sensor (POS)</li> <li>• Camshaft position sensor (PHASE) (bank 2)</li> <li>• Battery current sensor</li> <li>• EVAP control system pressure sensor</li> <li>• Refrigerant pressure sensor</li> </ul> |

DTC CONFIRMATION PROCEDURE

1. PRECONDITIONING

If DTC Confirmation Procedure has been previously conducted, always perform the following procedure before conducting the next test.

1. Turn ignition switch OFF and wait at least 10 seconds.
2. Turn ignition switch ON.
3. Turn ignition switch OFF and wait at least 10 seconds.

TESTING CONDITION:

Before performing the following procedure, confirm that battery voltage is more than 10 V at idle.

>> GO TO 2.

2. PERFORM DTC CONFIRMATION PROCEDURE

1. Start engine and let it idle for 1 second.
2. Check DTC.

Is DTC detected?

- YES >> Go to [EC-927, "Diagnosis Procedure"](#).  
 NO >> INSPECTION END

Diagnosis Procedure

INFOID:000000007730066

1. CHECK GROUND CONNECTION

1. Turn ignition switch OFF.
2. Check ground connection M95. Refer to Ground Inspection in [GI-47, "Circuit Inspection"](#).

Is the inspection result normal?

- YES >> GO TO 2.  
 NO >> Repair or replace ground connection.

2. CHECK APP SENSOR 1 POWER SUPPLY CIRCUIT

1. Disconnect accelerator pedal position (APP) sensor harness connector.
2. Turn ignition switch ON.
3. Check the voltage between APP sensor harness connector and ground.

# P2138 APP SENSOR

[VQ37VHR FOR MEXICO]

< DTC/CIRCUIT DIAGNOSIS >

| APP sensor                             |                                    | Ground | Voltage (Approx.) |
|--|------------------------------------|--------|-------------------|
| Connector                              | Terminal                           |        |                   |
| M153 <sup>*1</sup><br>M9 <sup>*2</sup> | 6 <sup>*1</sup><br>5 <sup>*2</sup> | Ground | 5 V               |

\*1: With ICC

\*2: Without ICC

Is the inspection result normal?

YES >> GO TO 4.

NO >> GO TO 3 (With ICC).

NO >> Repair open circuit, short to ground or short to power in harness or connectors (Without ICC).

## 3.DETECT MALFUNCTIONING PART

Check the following.

- Harness connectors M150, M151
- Harness for open or short between ECM and accelerator pedal position sensor

>> Repair open circuit, short to ground or short to power in harness or connectors.

## 4.CHECK APP SENSOR 2 POWER SUPPLY CIRCUIT-I

1. Turn ignition switch ON.
2. Check the voltage between APP sensor harness connector and ground.

| APP sensor                             |                                    | Ground | Voltage (Approx.) |
|--|------------------------------------|--------|-------------------|
| Connector                              | Terminal                           |        |                   |
| M153 <sup>*1</sup><br>M9 <sup>*2</sup> | 3 <sup>*1</sup><br>6 <sup>*2</sup> | Ground | 5 V               |

\*1: With ICC

\*2: Without ICC

Is the inspection result normal?

YES >> GO TO 9.

NO >> GO TO 5.

## 5.CHECK APP SENSOR 2 POWER SUPPLY CIRCUIT-II

1. Turn ignition switch OFF.
2. Disconnect ECM harness connector.
3. Check the continuity between APP sensor harness connector and ECM harness connector.

| APP sensor                             |                                    | ECM       |          | Continuity |
|--|------------------------------------|-----------|----------|------------|
| Connector                              | Terminal                           | Connector | Terminal |            |
| M153 <sup>*1</sup><br>M9 <sup>*2</sup> | 3 <sup>*1</sup><br>6 <sup>*2</sup> | M107      | 103      | Existed    |

\*1: With ICC

\*2: Without ICC

Is the inspection result normal?

YES >> GO TO 7.

NO >> GO TO 6 (With ICC).

NO >> Repair open circuit, short to ground or short to power in harness or connectors (Without ICC).

## 6.DETECT MALFUNCTIONING PART

Check the following.

- Harness connectors M105, M151
- Harness for open or short between ECM and accelerator pedal position sensor



>> Repair open circuit, short to ground or short to power in harness or connectors.

**7. CHECK SENSOR POWER SUPPLY CIRCUIT**

Check harness for short to power and short to ground, between the following terminals.

| ECM       |          | Sensor                              |  |                                    |
|-----------|----------|-------------------------------------|--|------------------------------------|
| Connector | Terminal | Name                                | Connector                              | Terminal                           |
| F101      | 46       | CKP sensor (POS)                    | F2                                     | 1                                  |
| F102      | 64       | CMP sensor (PHASE) (bank 2)         | F18                                    | 1                                  |
|           |          | Battery current sensor              | E21                                    |                                    |
| M107      | 103      | APP sensor                          | M153 <sup>*1</sup><br>M9 <sup>*2</sup> | 3 <sup>*1</sup><br>6 <sup>*2</sup> |
|           | 107      | EVAP control system pressure sensor | B73                                    | 3                                  |
|           |          | Refrigerant pressure sensor         | E77                                    | 3                                  |

\*1: With ICC

\*2: Without ICC

Is the inspection result normal?

YES >> GO TO 8.

NO >> Repair short to ground or short to power in harness or connectors.

**8. CHECK COMPONENTS**

Check the following.

- Crankshaft position sensor (POS) (Refer to [EC-781, "Component Inspection"](#).)
- Camshaft position sensor (PHASE) (bank 2) (Refer to [EC-786, "Component Inspection"](#).)
- Battery current sensor (Refer to [EC-870, "Component Inspection"](#).)
- Refrigerant pressure sensor (Refer to [EC-967, "Diagnosis Procedure"](#).)

Is the inspection result normal?

YES >> GO TO 15.

NO >> Replace malfunctioning component.

**9. CHECK APP SENSOR GROUND CIRCUIT FOR OPEN AND SHORT**

1. Turn ignition switch OFF.
2. Disconnect ECM harness connector.
3. Check the continuity between APP sensor harness connector and ECM harness connector.

| APP sensor                             |                 | ECM       |          | Continuity |
|--|-----------------|-----------|----------|------------|
| Connector                              | Terminal        | Connector | Terminal |            |
| M153 <sup>*1</sup><br>M9 <sup>*2</sup> | 5 <sup>*1</sup> | M107      | 100      | Existed    |
|  | 4 <sup>*2</sup> |           | 104      |            |
|  | 2               |           |          |            |

\*1: With ICC

\*2: Without ICC

4. Also check harness for short to ground and short to power.

Is the inspection result normal?

YES >> GO TO 11.

NO >> GO TO 10 (With ICC).

NO >> Repair open circuit, short to ground or short to power in harness or connectors (Without ICC).

**10. DETECT MALFUNCTIONING PART**

Check the following.

- Harness connectors M150, M151
- Harness for open or short between ECM and accelerator pedal position sensor

>> Repair open circuit, short to ground or short to power in harness or connectors.

**11.CHECK APP SENSOR INPUT SIGNAL CIRCUIT FOR OPEN AND SHORT**

1. Check the continuity between APP sensor harness connector and ECM harness connector.

| APP sensor     |          | ECM       |          | Continuity |
|----------------|----------|-----------|----------|------------|
| Connector      | Terminal | Connector | Terminal |            |
| M153*1<br>M9*2 | 4*1      | M107      | 97       | Existed    |
|                | 3*2      |           | 98       |            |
|                | 1        |           |          |            |

\*1: With ICC

\*2: Without ICC

2. Also check harness for short to ground and short to power.

Is the inspection result normal?

YES >> GO TO 13.

NO >> GO TO 12 (With ICC).

NO >> Repair open circuit, short to ground or short to power in harness or connectors (Without ICC).

**12.DETECT MALFUNCTIONING PART**

Check the following.

- Harness connectors M150, M151
- Harness for open or short between ECM and accelerator pedal position sensor

>> Repair open circuit, short to ground or short to power in harness or connectors.

**13.CHECK APP SENSOR**

Refer to [EC-930, "Component Inspection"](#).

Is the inspection result normal?

YES >> GO TO 15.

NO >> GO TO 14.

**14.REPLACE ACCELERATOR PEDAL ASSEMBLY**

1. Replace accelerator pedal assembly.
2. Go to [EC-931, "Special Repair Requirement"](#).

>> INSPECTION END

**15.CHECK INTERMITTENT INCIDENT**

Refer to [GI-44, "Intermittent Incident"](#).

>> INSPECTION END

**Component Inspection**

INFOID:000000007730067

**1.CHECK ACCELERATOR PEDAL POSITION SENSOR**

1. Turn ignition switch OFF.
2. Reconnect all harness connectors disconnected.
3. Turn ignition switch ON.
4. Check the voltage ECM harness connector terminals as per the following.

# P2138 APP SENSOR

< DTC/CIRCUIT DIAGNOSIS >

[VQ37VHR FOR MEXICO]

| ECM       |                   |          | Condition         | Voltage (V)    |            |
|-----------|-------------------|----------|-------------------|----------------|------------|
| Connector | +                 | -        |                   |                |            |
|           | Terminal          | Terminal |                   |                |            |
| M107      | 97 (APP sensor 1) | 100      | Accelerator pedal | Fully released | 0.45 - 1.0 |
|           |                   |          | Fully depressed   | 4.2 - 4.8      |            |
|           | 98 (APP sensor 2) | 104      | Fully released    | 0.22 - 0.50    |            |
|           |                   |          | Fully depressed   | 2.1 - 2.5      |            |

Is the inspection result normal?

YES >> INSPECTION END

NO >> GO TO 2.

## 2. REPLACE ACCELERATOR PEDAL ASSEMBLY

1. Replace accelerator pedal assembly.
2. Go to [EC-920, "Special Repair Requirement"](#).

>> INSPECTION END

## Special Repair Requirement

INFOID:000000007730068

### 1. PERFORM ACCELERATOR PEDAL RELEASED POSITION LEARNING

Refer to [EC-656, "Work Procedure"](#).

>> GO TO 2.

### 2. PERFORM THROTTLE VALVE CLOSED POSITION LEARNING

Refer to [EC-657, "Work Procedure"](#).

>> GO TO 3.

### 3. PERFORM IDLE AIR VOLUME LEARNING

Refer to [EC-658, "Work Procedure"](#).

>> END

A

EC

C

D

E

F

G

H

I

J

K

L

M

N

O

P

# P2A00, P2A03 A/F SENSOR 1

< DTC/CIRCUIT DIAGNOSIS >

[VQ37VHR FOR MEXICO]

## P2A00, P2A03 A/F SENSOR 1

### DTC Logic

INFOID:000000007730069

#### DTC DETECTION LOGIC

To judge the malfunction, the A/F signal computed by ECM from the A/F sensor 1 signal is monitored not it will shift to LEAN side or RICH side.

| DTC No. | Trouble diagnosis name   | DTC detecting condition   | Possible Cause   |
|---------|--|---|--|
| P2A00   | Air fuel ratio (A/F) sensor 1 (bank 1) circuit range/performance | <ul style="list-style-type: none"><li>The output voltage computed by ECM from the A/F sensor 1 signal is shifts to the lean side for a specified period.</li><li>The A/F signal computed by ECM from the A/F sensor 1 signal is shifts to the rich side for a specified period.</li></ul> | <ul style="list-style-type: none"><li>A/F sensor 1</li><li>A/F sensor 1 heater</li><li>Heated oxygen sensor 2</li><li>Fuel pressure</li><li>Fuel injector</li><li>Intake air leaks</li><li>Exhaust gas leaks</li></ul> |
| P2A03   | Air fuel ratio (A/F) sensor 1 (bank 2) circuit range/performance |   |  |

#### DTC CONFIRMATION PROCEDURE

##### 1. PRECONDITIONING

If DTC Confirmation Procedure has been previously conducted, always perform the following procedure before conducting the next test.

1. Turn ignition switch OFF and wait at least 10 seconds.
2. Turn ignition switch ON.
3. Turn ignition switch OFF and wait at least 10 seconds.

##### TESTING CONDITION:

**Before performing the following procedure, confirm that battery voltage is more than 11 V at idle.**

>> GO TO 2.

##### 2. PERFORM DTC CONFIRMATION PROCEDURE

1. Clear the mixture ratio self-learning value. Refer to [EC-662, "Work Procedure"](#).
2. Turn ignition switch OFF and wait at least 10 seconds.
3. Turn ignition switch ON.
4. Turn ignition switch OFF and wait at least 10 seconds.
5. Start engine and keep the engine speed between 3,500 and 4,000 rpm for 1 minute under no load.
6. Let engine idle for 1 minute.
7. Keep engine speed between 2,500 and 3,000 rpm for 20 minutes.
8. Check 1st trip DTC.

##### Is 1st trip DTC detected?

- YES >> Go to [EC-932, "Diagnosis Procedure"](#).  
NO >> INSPECTION END

#### Diagnosis Procedure

INFOID:000000007730070

##### 1. CHECK GROUND CONNECTION

1. Turn ignition switch OFF.
2. Check ground connection M95. Refer to Ground Inspection in [GI-47, "Circuit Inspection"](#).

##### Is the inspection result normal?

- YES >> GO TO 2.  
NO >> Repair or replace ground connection.

##### 2. RETIGHTEN A/F SENSOR 1 AND HEATED OXYGEN SENSOR 2

1. Loosen and retighten the A/F sensor 1 and heated oxygen sensor 2. Refer to [EM-36, "Removal and Installation"](#).

>> GO TO 3.

< DTC/CIRCUIT DIAGNOSIS >

**3.CHECK FOR EXHAUST GAS LEAK**

1. Start engine and run it at idle.
2. Listen for an exhaust gas leak before the three way catalyst 2.

Is exhaust gas leak detected?

- YES >> Repair or replace.  
 NO >> GO TO 4.

**4.CHECK FOR INTAKE AIR LEAK**

1. Start engine and run it at idle.
2. Listen for an intake air leak after the mass air flow sensor.

Is intake air leak detected?

- YES >> Repair or replace.  
 NO >> GO TO 5.

**5.CLEAR THE MIXTURE RATIO SELF-LEARNING VALUE**

1. Clear the mixture ratio self-learning value. Refer to [EC-662, "Work Procedure"](#).
2. Run engine for at least 10 minutes at idle speed.

Is the 1st trip DTC P0171, P0172, P0174 or P0175 detected? Is it difficult to start engine?

- YES >> Perform trouble diagnosis for DTC P0171, P0174 or P0172, P0175. Refer to [EC-755, "Diagnosis Procedure"](#) or [EC-759, "Diagnosis Procedure"](#).  
 NO >> GO TO 6.

**6.CHECK HARNESS CONNECTOR**

1. Turn ignition switch OFF.
2. Disconnect A/F sensor 1 harness connector.
3. Check harness connector for water.

**Water should not exit.**

Is the inspection result normal?

- YES >> GO TO 7.  
 NO >> Repair or replace harness connector.

**7.CHECK A/F SENSOR 1 POWER SUPPLY CIRCUIT**

1. Turn ignition switch ON.
2. Check the voltage between A/F sensor 1 harness connector and ground.

| DTC   | A/F sensor 1 |           |          | Ground | Voltage         |
|-------|--------------|-----------|----------|--------|-----------------|
|       | Bank         | Connector | Terminal |        |                 |
| P2A00 | 1            | F74       | 4        | Ground | Battery voltage |
| P2A03 | 2            | F75       | 4        |        |                 |

Is the inspection result normal?

- YES >> GO TO 9.  
 NO >> GO TO 8.

**8.DETECT MALFUNCTIONING PART**

Check the following.

- Harness connectors E20, F40
- IPDM E/R harness connector E7
- 15 A fuse (No. 45)
- Harness for open or short between A/F sensor 1 and fuse

>> Repair or replace harness or connectors.

**9.CHECK A/F SENSOR 1 INPUT SIGNAL CIRCUIT FOR OPEN AND SHORT**

1. Turn ignition switch OFF.

A  
 EC  
 C  
 D  
 E  
 F  
 G  
 H  
 I  
 J  
 K  
 L  
 M  
 N  
 O  
 P

# P2A00, P2A03 A/F SENSOR 1

[VQ37VHR FOR MEXICO]

## < DTC/CIRCUIT DIAGNOSIS >

2. Disconnect ECM harness connector.
3. Check the continuity between A/F sensor 1 harness connector and ECM harness connector.

| DTC   | A/F sensor 1 |           |          | ECM       |          | Continuity |
|-------|--------------|-----------|----------|-----------|----------|------------|
|       | Bank         | Connector | Terminal | Connector | Terminal |            |
| P2A00 | 1            | F74       | 1        | F102      | 57       | Existed    |
|       |              |           | 2        |           | 61       |            |
| P2A03 | 2            | F75       | 1        |           | 65       |            |
|       |              |           | 2        |           | 66       |            |

4. Check the continuity between A/F sensor 1 harness connector and ground, or ECM harness connector and ground.

| DTC   | A/F sensor 1 |           |          | Ground | Continuity  |
|-------|--------------|-----------|----------|--------|-------------|
|       | Bank         | Connector | Terminal |        |             |
| P2A00 | 1            | F74       | 1        | Ground | Not existed |
|       |              |           | 2        |        |             |
| P2A03 | 2            | F75       | 1        |        |             |
|       |              |           | 2        |        |             |

| DTC   | ECM  |           |          | Ground | Continuity  |
|-------|------|-----------|----------|--------|-------------|
|       | Bank | Connector | Terminal |        |             |
| P2A00 | 1    | F102      | 57       | Ground | Not existed |
|       |      |           | 61       |        |             |
| P2A03 | 2    |           | 65       |        |             |
|       |      |           | 66       |        |             |

5. Also check harness for short to power.

Is the inspection result normal?

YES >> GO TO 10.

NO >> Repair open circuit, short to ground or short to power in harness or connectors.

## 10.CHECK A/F SENSOR 1 HEATER

Refer to [EC-699, "Component Inspection"](#).

Is the inspection result normal?

YES >> GO TO 11.

NO >> GO TO 13.

## 11.CHECK HEATED OXYGEN SENSOR 2

Refer to [EC-737, "Component Inspection"](#).

Is the inspection result normal?

YES >> GO TO 12.

NO >> Replace malfunctioning heated oxygen sensor 2. Refer to [EX-5, "VQ37VHR : Exploded View"](#).

## 12.CHECK INTERMITTENT INCIDENT

Perform [GI-44, "Intermittent Incident"](#).

Is the inspection result normal?

YES >> GO TO 13.

NO >> Repair or replace.

## 13.REPLACE AIR FUEL RATIO (A/F) SENSOR 1

Replace air fuel ratio (A/F) sensor 1.

**CAUTION:**

# P2A00, P2A03 A/F SENSOR 1

[VQ37VHR FOR MEXICO]

< DTC/CIRCUIT DIAGNOSIS >

- Discard any A/F sensor which has been dropped from a height of more than 0.5 m (19.7 in) onto a hard surface such as a concrete floor; use a new one.
- Before installing new A/F sensor, clean exhaust system threads using Oxygen Sensor Thread Cleaner [commercial service tool (J-43897-18 or J-43897-12)] and approved Anti-seize Lubricant (commercial service tool).

Do you have CONSULT?

YES >> GO TO 14.

NO >> GO TO 15.

## 14. CONFIRM A/F ADJUSTMENT DATA

**Ⓜ With CONSULT**

1. Turn ignition switch ON.
2. Select "A/F ADJ-B1" and "A/F ADJ-B2" in "DATA MONITOR" mode with CONSULT.
3. Make sure that "0.000" is displayed on CONSULT screen.

Is "0.000" displayed?

YES >> INSPECTION END

NO >> GO TO 15.

## 15. CLEAR THE MIXTURE RATIO SELF-LEARNING VALUE

Clear the mixture ratio self-learning value. Refer to [EC-662. "Work Procedure"](#).

Do you have CONSULT?

YES >> GO TO 16.

NO >> INSPECTION END

## 16. CONFIRM A/F ADJUSTMENT DATA

**Ⓜ With CONSULT**

1. Turn ignition switch ON.
2. Select "A/F ADJ-B1" and "A/F ADJ-B2" in "DATA MONITOR" mode with CONSULT.
3. Make sure that "0.000" is displayed on CONSULT screen.

>> INSPECTION END

A  
EC  
C  
D  
E  
F  
G  
H  
I  
J  
K  
L  
M  
N  
O  
P

# ASCD BRAKE SWITCH

< DTC/CIRCUIT DIAGNOSIS >

[VQ37VHR FOR MEXICO]

## ASCD BRAKE SWITCH

### Component Function Check

INFOID:000000007730071

#### 1. CHECK ASCD BRAKE SWITCH FUNCTION

##### With CONSULT

1. Turn ignition switch ON.
2. Select "BRAKE SW1" in "DATA MONITOR" mode with CONSULT.
3. Check "BRAKE SW1" indication under the following conditions.

| Monitor item | Condition   |                    | Indication |
|--------------|-------------|--------------------|------------|
| BRAKE SW1    | Brake pedal | Slightly depressed | OFF        |
|              | Brake pedal | Fully released     | ON         |

##### Without CONSULT

1. Turn ignition switch ON.
2. Check the voltage between ECM harness connector terminals as per the following.

| Connector | ECM                               |          | Condition   |                    | Voltage (V)     |
|-----------|-----------------------------------|----------|-------------|--------------------|-----------------|
|           | +                                 | -        |             |                    |                 |
|           | Terminal                          | Terminal |             |                    |                 |
| M107      | 126<br>(ASCD brake switch signal) | 128      | Brake pedal | Slightly depressed | Approx. 0       |
|           |                                   |          | Brake pedal | Fully released     | Battery voltage |

Is the inspection result normal?

- YES >> INSPECTION END  
NO >> Go to [EC-936. "Diagnosis Procedure"](#).

### Diagnosis Procedure

INFOID:000000007730072

#### 1. CHECK ASCD BRAKE SWITCH POWER SUPPLY CIRCUIT

1. Turn ignition switch OFF.
2. Disconnect ASCD brake switch harness connector.
3. Turn ignition switch ON.
4. Check the voltage between ASCD brake switch harness connector and ground.

| ASCD brake switch |          | Ground | Voltage         |
|-------------------|----------|--------|-----------------|
| Connector         | Terminal |        |                 |
| E109              | 1        | Ground | Battery voltage |

Is the inspection result normal?

- YES >> GO TO 3.  
NO >> GO TO 2.

#### 2. DETECT MALFUNCTIONING PART

Check the following.

- Fuse block (J/B) connector E103
- 10 A fuse (No. 3)
- Harness for open or short between ASCD brake switch and fuse

>> Repair open circuit or short to ground in harness or connectors.

#### 3. CHECK ASCD BRAKE SWITCH INPUT SIGNAL CIRCUIT FOR OPEN AND SHORT

1. Turn ignition switch OFF.
2. Disconnect ECM harness connector.
3. Check the continuity between ASCD brake switch harness connector and ECM harness connector.



# ASCD BRAKE SWITCH

< DTC/CIRCUIT DIAGNOSIS >

[VQ37VHR FOR MEXICO]

| ASCD brake switch |          | ECM       |          | Continuity |
|-------------------|----------|-----------|----------|------------|
| Connector         | Terminal | Connector | Terminal |            |
| E109              | 2        | M107      | 126      | Existed    |

4. Also check harness for short to ground and short to power.

Is the inspection result normal?

- YES >> GO TO 5.
- NO >> GO TO 4.

## 4. DETECT MALFUNCTIONING PART

Check the following.

- Harness connectors E106, M6
- Harness for open or short between ECM and ASCD brake switch

>> Repair open circuit, short to ground or short to power in harness or connectors.

## 5. CHECK ASCD BRAKE SWITCH

Refer to [EC-937, "Component Inspection \(ASCD Brake Switch\)"](#)

Is the inspection result normal?

- YES >> GO TO 6.
- NO >> Replace ASCD brake switch. Refer to [BR-18, "Exploded View"](#).

## 6. CHECK INTERMITTENT INCIDENT

Refer to [GI-44, "Intermittent Incident"](#).

>> INSPECTION END

## Component Inspection (ASCD Brake Switch)

INFOID:000000007730073

### 1. CHECK ASCD BRAKE SWITCH-I

1. Turn ignition switch OFF.
2. Disconnect ASCD brake switch harness connector.
3. Check the continuity between ASCD brake switch terminals under the following conditions.

| Terminals | Condition   |                    | Continuity  |
|-----------|-------------|--------------------|-------------|
| 1 and 2   | Brake pedal | Fully released     | Existed     |
|           |             | Slightly depressed | Not existed |

Is the inspection result normal?

- YES >> INSPECTION END
- NO >> GO TO 2.

### 2. CHECK ASCD BRAKE SWITCH-II

1. Adjust ASCD brake switch installation. Refer to [BR-19, "Inspection and Adjustment"](#).
2. Check the continuity between ASCD brake switch terminals under the following conditions.

| Terminals | Condition   |                    | Continuity  |
|-----------|-------------|--------------------|-------------|
| 1 and 2   | Brake pedal | Fully released     | Existed     |
|           |             | Slightly depressed | Not existed |

Is the inspection result normal?

- YES >> INSPECTION END
- NO >> Replace ASCD brake switch. Refer to [BR-18, "Exploded View"](#).

## ASC D INDICATOR

### Component Function Check

INFOID:000000007730074

#### 1. CHECK ASC D INDICATOR FUNCTION

Check ASC D indicator under the following conditions.

| ASC D INDICATOR | CONDITION   | SPECIFICATION  |               |
|-----------------|---|--|---------------|
| CRUISE LAMP     | <ul style="list-style-type: none"> <li>• Ignition switch: ON</li> </ul>   | <ul style="list-style-type: none"> <li>• MAIN switch: Pressed at the 1st time → at the 2nd time</li> </ul> | ON → OFF      |
| SET LAMP        | <ul style="list-style-type: none"> <li>• MAIN switch: ON</li> <li>• When vehicle speed is between 40 km/h (25 MPH) and 144 km/h (89 MPH)</li> </ul> | <ul style="list-style-type: none"> <li>• ASC D: Operating</li> <li>• ASC D: Not operating</li> </ul>       | ON<br><br>OFF |

Is the inspection result normal?

YES >> INSPECTION END

NO >> Go to [EC-938, "Diagnosis Procedure"](#).

### Diagnosis Procedure

INFOID:000000007730075

#### 1. CHECK DTC

Check that DTC UXXXX is not displayed.

Is the inspection result normal?

YES >> GO TO 2.

NO >> Perform trouble diagnosis for DTC UXXXX.

#### 2. CHECK DTC WITH "COMBINATION METER"

Refer to [MWI-31, "CONSULT Function"](#).

Is the inspection result normal?

YES >> GO TO 3.

NO >> Repair or replace.

#### 3. CHECK INTERMITTENT INCIDENT

Refer to [GI-44, "Intermittent Incident"](#).

Is the inspection result normal?

YES >> Replace combination meter. Refer to [MWI-79, "Exploded View"](#).

NO >> Repair or replace.

COOLING FAN

Component Function Check

INFOID:000000007730076

1. CHECK COOLING FAN FUNCTION

 With CONSULT

1. Turn ignition switch ON.
2. Perform "FAN DUTY CONTROL" in "ACTIVE TEST" mode with CONSULT.
3. Make sure that cooling fan speed varies according to the percentage.

 Without CONSULT

1. Perform IPDM E/R auto active test and check cooling fan motors operation, refer to [PCS-12. "Diagnosis Description"](#).
2. Make sure that cooling fan operates.

Is the inspection result normal?

- YES >> INSPECTION END  
 NO >> Go to [EC-939. "Diagnosis Procedure"](#).

Diagnosis Procedure

INFOID:000000007730077

1. CHECK COOLING FAN CONTROL MODULE POWER SUPPLY CIRCUIT-I

1. Turn ignition switch OFF.
2. Disconnect cooling fan control module harness connector.
3. Turn ignition switch ON.
4. Check the voltage between cooling fan control module harness connector and ground.

| Cooling fan control module |          | Ground | Voltage         |
|----------------------------|----------|--------|-----------------|
| Connector                  | Terminal |        |                 |
| E37                        | 3        | Ground | Battery voltage |

Is the inspection result normal?

- YES >> GO TO 2.  
 NO >> GO TO 7.

2. CHECK COOLING FAN CONTROL MODULE GROUND CIRCUIT

1. Turn ignition switch OFF.
2. Check the continuity between cooling fan control module harness connector and ground.

| Cooling fan control module |          | Ground | Continuity |
|----------------------------|----------|--------|------------|
| Connector                  | Terminal |        |            |
| E37                        | 1        | Ground | Existed    |

3. Also check harness for short to power.

Is the inspection result normal?

- YES >> GO TO 3.  
 NO >> Repair open circuit or short to power in harness or connectors.

3. CHECK IPDM E/R GROUND CIRCUIT

1. Disconnect IPDM E/R harness connectors.
2. Check the continuity between IPDM E/R harness connector and ground.

| IPDM E/R  |          | Ground | Continuity |
|-----------|----------|--------|------------|
| Connector | Terminal |        |            |
| E5        | 11       | Ground | Existed    |
| E6        | 41       |        |            |

3. Also check harness for short to power.

# COOLING FAN

[VQ37VHR FOR MEXICO]

## < DTC/CIRCUIT DIAGNOSIS >

### Is the inspection result normal?

YES >> GO TO 4.

NO >> Repair open circuit or short to power in harness or connectors.

### 4. CHECK COOLING FAN CONTROL SIGNAL CIRCUIT

1. Disconnect IPDM E/R harness connector.
2. Check the continuity between IPDM E/R harness connector and cooling fan control module harness connector.

| IPDM E/R  |          | Cooling fan control module |          | Continuity |
|-----------|----------|----------------------------|----------|------------|
| Connector | Terminal | Connector                  | Terminal |            |
| E9        | 97       | E37                        | 2        | Existed    |

3. Also check harness for short to ground and short to power.

### Is the inspection result normal?

YES >> GO TO 5.

NO >> Repair open circuit, short to ground or short to power in harness or connectors.

### 5. CHECK COOLING FAN CONTROL MODULE OUTPUT SIGNAL CIRCUIT

1. Reconnect all harness connectors disconnected.
2. Disconnect cooling fan control module harness connectors.
3. Turn ignition switch ON.
4. Check the voltage between cooling fan control module harness connector and ground.

| Cooling fan control module |          | Ground | Voltage         |
|----------------------------|----------|--------|-----------------|
| Connector                  | Terminal |        |                 |
| E301                       | 4        | Ground | Battery voltage |
| E302                       | 6        |        |                 |

### Is the inspection result normal?

YES >> GO TO 6.

NO >> Replace cooling fan control module. Refer to [CO-18, "Exploded View"](#).

### 6. CHECK COOLING FAN MOTORS -1 AND -2

Refer to [EC-941, "Component Inspection \(Cooling Fan Motor\)"](#).

### Is the inspection result normal?

YES >> GO TO 11.

NO >> Replace cooling fan motor. Refer to [CO-18, "Exploded View"](#).

### 7. CHECK COOLING FAN CONTROL MODULE POWER SUPPLY CIRCUIT-II

1. Turn ignition switch OFF.
2. Disconnect cooling fan relay.
3. Turn ignition switch ON.
4. Check the voltage between cooling fan relay harness connector and ground.

| Cooling fan relay |          | Ground | Voltage         |
|-------------------|----------|--------|-----------------|
| Connector         | Terminal |        |                 |
| E17               | 1        | Ground | Battery voltage |
|                   | 3        |        |                 |

### Is the inspection result normal?

YES >> GO TO 9.

NO >> GO TO 8.

### 8. DETECT MALFUNCTIONING PART

Check the following.

- 10A fuse (No. 42)

# COOLING FAN

[VQ37VHR FOR MEXICO]

## < DTC/CIRCUIT DIAGNOSIS >

- IPDM E/R harness connector E7
- 50A fusible link (letter O)
- Harness for open or short between cooling fan relay and fuse
- Harness for open or short between cooling fan relay and battery

>> Repair open circuit, short to ground or short to power in harness or connectors.

### 9. CHECK COOLING FAN CONTROL MODULE POWER SUPPLY CIRCUIT-III

1. Turn ignition switch OFF.
2. Disconnect IPDM E/R harness connector.
3. Check the continuity between cooling fan relay harness connector and IPDM E/R harness connector.

| Cooling fan relay |          | IPDM E/R  |          | Continuity |
|-------------------|----------|-----------|----------|------------|
| Connector         | Terminal | Connector | Terminal |            |
| E17               | 2        | E7        | 73       | Existed    |

4. Check the continuity between cooling fan relay harness connector and cooling fan control module harness connector.

| Cooling fan relay |          | Cooling fan control module |          | Continuity |
|-------------------|----------|----------------------------|----------|------------|
| Connector         | Terminal | Connector                  | Terminal |            |
| E17               | 5        | E37                        | 3        | Existed    |

5. Also check harness for short to ground and short to power.

Is the inspection result normal?

YES >> GO TO 10.

NO >> Repair open circuit, short to ground or short to power in harness or connectors.

### 10. CHECK COOLING FAN RELAY

Refer to [EC-942, "Component Inspection \(Cooling Fan Relay\)"](#).

Is the inspection result normal?

YES >> GO TO 11.

NO >> Replace cooling fan relay.

### 11. CHECK INTERMITTENT INCIDENT

Perform [GI-44, "Intermittent Incident"](#).

Is the inspection result normal?

YES >> Replace IPDM E/R. Refer to [PCS-33, "Exploded View"](#).

NO >> Repair or replace harness connectors.

## Component Inspection (Cooling Fan Motor)

INFOID:000000007730078

### 1. CHECK COOLING FAN MOTOR

1. Turn ignition switch OFF.
2. Disconnect cooling fan control module harness connectors.
3. Supply cooling fan control module terminals with battery voltage and check operation.

| Cooling fan control module |           |          |     | Operation             |
|----------------------------|-----------|----------|-----|-----------------------|
| Motor                      | Connector | Terminal |     |                       |
|                            |           | (+)      | (-) |                       |
| 1                          | E301      | 4        | 5   | Cooling fan operates. |
| 2                          | E302      | 6        | 7   |                       |

Is the inspection result normal?

YES >> INSPECTION END

NO >> Replace cooling fan motor. Refer to [CO-18, "Exploded View"](#).

# COOLING FAN

< DTC/CIRCUIT DIAGNOSIS >

[VQ37VHR FOR MEXICO]

## Component Inspection (Cooling Fan Relay)

INFOID:000000007730079

### 1. CHECK COOLING FAN RELAY

1. Turn ignition switch OFF.
2. Remove cooling fan relay.
3. Check the continuity between cooling fan relay terminals under the following conditions.

| Terminals | Conditions   | Continuity  |
|-----------|--|-------------|
| 3 and 5   | 12 V direct current supply between terminals 1 and 2 | Existed     |
|           | No current supply                                    | Not existed |

Is the inspection result normal?

- YES >> INSPECTION END  
NO >> Replace cooling fan relay.

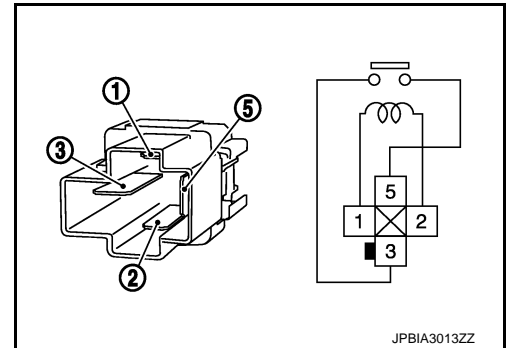

## ELECTRICAL LOAD SIGNAL

## Description

INFOID:000000007730080

The electrical load signal (Headlamp switch signal, rear window defogger switch signal, etc.) is transferred via the CAN communication line.

## Component Function Check

INFOID:000000007730081

## 1. CHECK REAR WINDOW DEFOGGER SWITCH FUNCTION

1. Turn ignition switch ON.
2. Connect CONSULT and select "DATA MONITOR" mode.
3. Select "LOAD SIGNAL" and check indication under the following conditions.

| Monitor item | Condition                   | Indication |     |
|--------------|-----------------------------|------------|-----|
| LOAD SIGNAL  | Rear window defogger switch | ON         | ON  |
|              |                             | OFF        | OFF |

Is the inspection result normal?

YES >> GO TO 2.

NO >> Go to [EC-943, "Diagnosis Procedure"](#).

## 2. CHECK LIGHTING SWITCH FUNCTION

Check "LOAD SIGNAL" indication under the following conditions.

| Monitor item | Condition       | Indication         |     |
|--------------|-----------------|--------------------|-----|
| LOAD SIGNAL  | Lighting switch | ON at 2nd position | ON  |
|              |                 | OFF                | OFF |

Is the inspection result normal?

YES >> GO TO 3.

NO >> Go to [EC-943, "Diagnosis Procedure"](#).

## 3. CHECK HEATER FAN CONTROL SWITCH FUNCTION

Select "HEATER FAN SW" and check indication under the following conditions.

| Monitor item  | Condition                 | Indication |     |
|---------------|---------------------------|------------|-----|
| HEATER FAN SW | Heater fan control switch | ON         | ON  |
|               |                           | OFF        | OFF |

Is the inspection result normal?

YES >> INSPECTION END

NO >> Go to [EC-943, "Diagnosis Procedure"](#).

## Diagnosis Procedure

INFOID:000000007730082

## 1. INSPECTION START

Confirm the malfunctioning circuit (rear window defogger, headlamp or heater fan). Refer to [EC-943, "Component Function Check"](#).

Which circuit is related to the incident?

Rear window defogger>>GO TO 2.

Headlamp>>GO TO 3.

Heater fan>>GO TO 4.

## 2. CHECK REAR WINDOW DEFOGGER SYSTEM

Refer to [DEF-11, "Work Flow"](#).

## ELECTRICAL LOAD SIGNAL

< DTC/CIRCUIT DIAGNOSIS >

[VQ37VHR FOR MEXICO]

---

>> INSPECTION END

### 3.CHECK HEADLAMP SYSTEM

---

Refer to [EXL-49, "Work Flow"](#).

>> INSPECTION END

### 4.CHECK HEATER FAN CONTROL SYSTEM

---

Refer to [HAC-68, "Work Flow"](#).

>> INSPECTION END



## FUEL INJECTOR

### Component Function Check

INFOID:000000007730083

#### 1.INSPECTION START

Turn ignition switch to START.

Are any cylinders ignited?

- YES >> GO TO 2.
- NO >> Go to [EC-945. "Diagnosis Procedure"](#).

#### 2.CHECK FUEL INJECTOR FUNCTION

##### With CONSULT

1. Start engine.
2. Perform "POWER BALANCE" in "ACTIVE TEST" mode with CONSULT.
3. Make sure that each circuit produces a momentary engine speed drop.

##### Without CONSULT

1. Start engine.
2. Listen to each fuel injector operating sound.

**Clicking sound should be heard.**

Is the inspection result normal?

- YES >> INSPECTION END
- NO >> Go to [EC-945. "Diagnosis Procedure"](#).

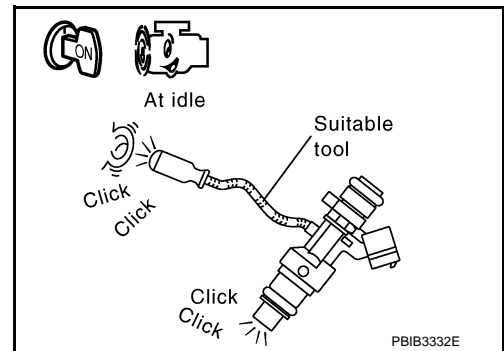

### Diagnosis Procedure

INFOID:000000007730084

#### 1.CHECK FUEL INJECTOR POWER SUPPLY CIRCUIT

1. Turn ignition switch OFF.
2. Disconnect fuel injector harness connector.
3. Turn ignition switch ON.
4. Check the voltage between fuel injector harness connector and ground.

| Fuel injector |           |          | Ground | Voltage         |
|---------------|-----------|----------|--------|-----------------|
| Cylinder      | Connector | Terminal |        |                 |
| 1             | F121      | 1        | Ground | Battery voltage |
| 2             | F122      | 1        |        |                 |
| 3             | F123      | 1        |        |                 |
| 4             | F124      | 1        |        |                 |
| 5             | F125      | 1        |        |                 |
| 6             | F126      | 1        |        |                 |

Is the inspection result normal?

- YES >> GO TO 3.
- NO >> GO TO 2.

#### 2.DETECT MALFUNCTIONING PART

Check the following.

- Harness connectors E20, F40
- Harness connectors F30, F120
- IPDM E/R harness connector E7
- 10 A fuse (No. 44)

# FUEL INJECTOR

[VQ37VHR FOR MEXICO]

< DTC/CIRCUIT DIAGNOSIS >

- Harness for open or short between fuel injector and fuse

>> Repair open circuit, short to ground or short to power in harness or connectors.

## 3.CHECK FUEL INJECTOR OUTPUT SIGNAL CIRCUIT FOR OPEN AND SHORT

1. Turn ignition switch OFF.
2. Disconnect ECM harness connector.
3. Check the continuity between fuel injector harness connector and ECM harness connector.

| Fuel injector |           |          | ECM       |          | Continuity |
|---------------|-----------|----------|-----------|----------|------------|
| Cylinder      | Connector | Terminal | Connector | Terminal |            |
| 1             | F121      | 2        | F102      | 89       | Existed    |
| 2             | F122      | 2        |           | 85       |            |
| 3             | F123      | 2        |           | 81       |            |
| 4             | F124      | 2        |           | 90       |            |
| 5             | F125      | 2        |           | 86       |            |
| 6             | F126      | 2        |           | 82       |            |

4. Also check harness for short to ground and short to power.

Is the inspection result normal?

- YES >> GO TO 5.  
NO >> GO TO 4

## 4.DETECT MALFUNCTIONING PART

Check the following.

- Harness connectors F30, F120
- Harness for open or short between fuel injector and ECM

>> Repair open circuit, short to ground or short to power in harness or connectors.

## 5.CHECK FUEL INJECTOR

Refer to [EC-946, "Component Inspection"](#).

Is the inspection result normal?

- YES >> GO TO 6.  
NO >> Replace malfunctioning fuel injector. Refer to [EM-39, "Exploded View"](#).

## 6.CHECK INTERMITTENT INCIDENT

Refer to [GI-44, "Intermittent Incident"](#).

Is the inspection result normal?

- YES >> Replace IPDM E/R. Refer to [PCS-33, "Exploded View"](#).  
NO >> Repair open circuit, short to ground or short to power in harness or connectors.

## Component Inspection

INFOID:000000007730085

### 1.CHECK FUEL INJECTOR

1. Turn ignition switch OFF.
2. Disconnect fuel injector harness connector.
3. Check resistance between fuel injector terminals as follows.

| Terminals | Resistance (Ω)                          |
|-----------|---|
| 1 and 2   | 11.1 - 14.3 [at 10 - 60°C (60 - 140°F)] |

Is the inspection result normal?

- YES >> INSPECTION END  
NO >> Replace malfunctioning fuel injector. Refer to [EM-39, "Exploded View"](#).

# FUEL PUMP

< DTC/CIRCUIT DIAGNOSIS >

[VQ37VHR FOR MEXICO]

## FUEL PUMP

### Component Function Check

INFOID:000000007730086

#### 1.CHECK FUEL PUMP FUNCTION

1. Turn ignition switch ON.
2. Pinch fuel feed hose (1) with two fingers.

**Fuel pressure pulsation should be felt on the fuel feed hose for 1 second after ignition switch is turned ON.**

Is the inspection result normal?

- YES >> INSPECTION END  
NO >> [EC-947, "Diagnosis Procedure"](#).

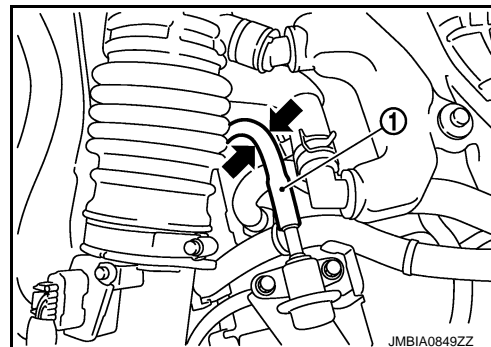

### Diagnosis Procedure

INFOID:000000007730087

#### 1.CHECK FUEL PUMP POWER SUPPLY CIRCUIT-I

1. Turn ignition switch OFF.
2. Disconnect ECM harness connector.
3. Turn ignition switch ON.
4. Check the voltage between ECM harness connector and ground.

| ECM       |          | Ground | Voltage         |
|-----------|----------|--------|-----------------|
| Connector | Terminal |        |                 |
| F101      | 22       | Ground | Battery voltage |

Is the inspection result normal?

- YES >> GO TO 4.  
NO >> GO TO 2.

#### 2.CHECK FUEL PUMP POWER SUPPLY CIRCUIT-II

Check the voltage between IPDM E/R harness connector and ground.

| IPDM E/R  |          | Ground | Voltage         |
|-----------|----------|--------|-----------------|
| Connector | Terminal |        |                 |
| E7        | 77       | Ground | Battery voltage |

Is the inspection result normal?

- YES >> GO TO 3.  
NO >> GO TO 10.

#### 3.DETECT MALFUNCTIONING PART

Check the following.

- Harness connectors E20, F40
- Harness for open or short between IPDM E/R and ECM

>> Repair open circuit, short to ground or short to power in harness or connectors.

#### 4.CHECK FUEL PUMP POWER SUPPLY CIRCUIT-III

1. Turn ignition switch OFF.
2. Reconnect all harness connectors disconnected.
3. Disconnect "fuel level sensor unit and fuel pump" harness connector.
4. Turn ignition switch ON.

# FUEL PUMP

< DTC/CIRCUIT DIAGNOSIS >

[VQ37VHR FOR MEXICO]

5. Check the voltage between “fuel level sensor unit and fuel pump” harness connector and ground.

| Fuel level sensor unit and fuel pump |          | Ground | Voltage   |
|--------------------------------------|----------|--------|---|
| Connector                            | Terminal |        |   |
| B241                                 | 1        | Ground | Battery voltage should exist for 1 second after ignition switch is turned ON. |

Is the inspection result normal?

YES >> GO TO 8.

NO >> GO TO 5.

## 5.CHECK 15A FUSE

1. Turn ignition switch OFF.
2. Disconnect 15A fuse (No. 41) from IPDM E/R.
3. Check 15 A fuse.

Is the inspection result normal?

YES >> GO TO 6.

NO >> Replace fuse.

## 6.CHECK FUEL PUMP POWER SUPPLY CIRCUIT-IV

1. Disconnect IPDM E/R harness connector.
2. Check the continuity between IPDM E/R harness connector and “fuel level sensor unit and fuel pump” harness connector.

| IPDM E/R  |          | Fuel level sensor unit and fuel pump |          | Continuity |
|-----------|----------|--------------------------------------|----------|------------|
| Connector | Terminal | Connector                            | Terminal |            |
| E5        | 13       | B241                                 | 1        | Existed    |

3. Also check harness for short to ground and short to power.

Is the inspection result normal?

YES >> GO TO 10.

NO >> GO TO 7.

## 7.DETECT MALFUNCTIONING PART

Check the following.

- Harness connectors E105, B3
- Harness connectors B51, B230
- IPDM E/R harness connector E5
- Harness for open or short between IPDM E/R and “fuel level sensor unit and fuel pump”

>> Repair open circuit, short to ground or short to power in harness or connectors.

## 8.CHECK FUEL PUMP GROUND CIRCUIT

1. Turn ignition switch OFF.
2. Check the continuity between “fuel level sensor unit and fuel pump” harness connector and ground.

| Fuel level sensor unit and fuel pump |          | Ground | Continuity |
|--------------------------------------|----------|--------|------------|
| Connector                            | Terminal |        |            |
| B241                                 | 3        | Ground | Existed    |

3. Also check harness for short to power.

Is the inspection result normal?

YES >> GO TO 9.

NO >> Repair open circuit or short to power in harness or connectors.

## 9.CHECK FUEL PUMP

# FUEL PUMP

[VQ37VHR FOR MEXICO]

< DTC/CIRCUIT DIAGNOSIS >

Refer to [EC-949, "Component Inspection"](#).

Is the inspection result normal?

YES >> GO TO 10.

NO >> Replace fuel pump. Refer to [FL-5, "Exploded View"](#).

## 10.CHECK INTERMITTENT INCIDENT

Refer to [GI-44, "Intermittent Incident"](#).

Is the inspection result normal?

YES >> Replace IPDM E/R. Refer to [PCS-33, "Exploded View"](#).

NO >> Repair or replace harness or connectors.

## Component Inspection

INFOID:000000007730088

## 1.CHECK FUEL PUMP

1. Turn ignition switch OFF.
2. Disconnect "fuel level sensor unit and fuel pump" harness connector.
3. Check resistance between "fuel level sensor unit and fuel pump" terminals as follows.

| Terminals | Resistance ( $\Omega$ )    |
|-----------|----------------------------|
| 1 and 3   | 0.2 - 5.0 [at 25°C (77°F)] |

Is the inspection result normal?

YES >> INSPECTION END

NO >> Replace "fuel level sensor unit and fuel pump". Refer to [FL-5, "Exploded View"](#).

A  
EC  
C  
D  
E  
F  
G  
H  
I  
J  
K  
L  
M  
N  
O  
P

## ICC BRAKE SWITCH

### Component Function Check

INFOID:000000007730089

#### 1. CHECK ICC BRAKE SWITCH FUNCTION

**④ With CONSULT**

1. Turn ignition switch ON.
2. Select "BRAKE SW1" in "DATA MONITOR" mode with CONSULT.
3. Check "BRAKE SW1" indication under the following conditions.

| Monitor item | Condition   |                    | Indication |
|--------------|-------------|--------------------|------------|
| BRAKE SW1    | Brake pedal | Slightly depressed | OFF        |
|              | Brake pedal | Fully released     | ON         |

**⊗ Without CONSULT**

1. Turn ignition switch ON.
2. Check the voltage between ECM harness connector terminals as per the following.

| ECM       |                                  |          | Condition   | Voltage (V)        |                 |
|-----------|----------------------------------|----------|-------------|--------------------|-----------------|
| Connector | +                                | -        |             |                    |                 |
|           |                                  | Terminal | Terminal    |                    |                 |
| M107      | 126<br>(ICC brake switch signal) | 128      | Brake pedal | Slightly depressed | Approx. 0       |
|           |                                  |          |             | Fully released     | Battery voltage |

Is the inspection result normal?

- YES >> INSPECTION END  
 NO >> Go to [EC-950, "Diagnosis Procedure"](#).

### Diagnosis Procedure

INFOID:000000007730090

#### 1. CHECK ICC BRAKE SWITCH POWER SUPPLY CIRCUIT

1. Turn ignition switch OFF.
2. Disconnect ICC brake switch harness connector.
3. Turn ignition switch ON.
4. Check the voltage between ICC brake switch harness connector and ground.

| ICC brake switch |          | Ground | Voltage         |
|------------------|----------|--------|-----------------|
| Connector        | Terminal |        |                 |
| E114             | 1        | Ground | Battery voltage |

Is the inspection result normal?

- YES >> GO TO 3.  
 NO >> GO TO 2.

#### 2. DETECT MALFUNCTIONING PART

Check the following.

- Fuse block (J/B) connector E103
- 10A fuse (No. 3)
- Harness for open or short between ICC brake switch and fuse

>> Repair open circuit or short to ground in harness or connectors.

#### 3. CHECK ICC BRAKE SWITCH INPUT SIGNAL CIRCUIT FOR OPEN AND SHORT

1. Turn ignition switch OFF.
2. Disconnect ECM harness connector.

# ICC BRAKE SWITCH

[VQ37VHR FOR MEXICO]

## < DTC/CIRCUIT DIAGNOSIS >

3. Check the continuity between ICC brake switch harness connector and ECM harness connector.

| ICC brake switch |          | ECM       |          | Continuity |
|------------------|----------|-----------|----------|------------|
| Connector        | Terminal | Connector | Terminal |            |
| E114             | 2        | M107      | 126      | Existed    |

4. Also check harness for short to ground and short to power.

Is the inspection result normal?

YES >> GO TO 5.

NO >> GO TO 4.

## 4. DETECT MALFUNCTIONING PART

Check the following.

- Harness connectors E106, M6
- Harness for open or short between ICC brake switch and ECM

>> Repair open circuit, short to ground or short to power in harness or connectors.

## 5. CHECK ICC BRAKE SWITCH

Refer to [EC-951, "Component Inspection \(ICC Brake Switch\)"](#).

Is the inspection result normal?

YES >> GO TO 6.

NO >> Replace ICC brake switch. Refer to [BR-18, "Exploded View"](#).

## 6. CHECK INTERMITTENT INCIDENT

Refer to [GI-44, "Intermittent Incident"](#).

>> INSPECTION END

## Component Inspection (ICC Brake Switch)

INFOID:000000007730091

### 1. CHECK ICC BRAKE SWITCH-I

1. Turn ignition switch OFF.
2. Disconnect ICC brake switch harness connector.
3. Check the continuity between ICC brake switch terminals under the following conditions.

| Terminals | Condition   |                    | Continuity  |
|-----------|-------------|--------------------|-------------|
| 1 and 2   | Brake pedal | Fully released     | Existed     |
|           |             | Slightly depressed | Not existed |

Is the inspection result normal?

YES >> INSPECTION END

NO >> GO TO 2.

### 2. CHECK ICC BRAKE SWITCH-II

1. Adjust ICC brake switch installation. Refer to [BR-19, "Inspection and Adjustment"](#).
2. Check the continuity between ICC brake switch terminals under the following conditions.

| Terminals | Condition   |                    | Continuity  |
|-----------|-------------|--------------------|-------------|
| 1 and 2   | Brake pedal | Fully released     | Existed     |
|           |             | Slightly depressed | Not existed |

Is the inspection result normal?

YES >> INSPECTION END

NO >> Replace ICC brake switch. Refer to [BR-18, "Exploded View"](#).

IGNITION SIGNAL

Component Function Check

INFOID:000000007730092

1.INSPECTION START

Turn ignition switch OFF, and restart engine.

Does the engine start?

- YES-1 >> With CONSULT: GO TO 2.
- YES-2 >> Without CONSULT: GO TO 3.
- No >> Go to [EC-952, "Diagnosis Procedure"](#).

2.CHECK IGNITION SIGNAL FUNCTION

**With CONSULT**

1. Perform "POWER BALANCE" in "ACTIVE TEST" mode with CONSULT.
2. Make sure that each circuit produces a momentary engine speed drop.

Is the inspection result normal?

- YES >> INSPECTION END
- NO >> Go to [EC-952, "Diagnosis Procedure"](#).

3.CHECK IGNITION SIGNAL FUNCTION

**Without CONSULT**

1. Let engine idle.
2. Read the voltage signal between ECM harness connector terminals under the following conditions with an oscilloscope.

| ECM       |          |           |          | Voltage signal |
|-----------|----------|-----------|----------|----------------|
| +         |          | -         |          |                |
| Connector | Terminal | Connector | Terminal |                |
| F101      | 11       | M107      | 128      |                |
|           | 12       |           |          |                |
|           | 15       |           |          |                |
|           | 16       |           |          |                |
|           | 19       |           |          |                |
|           | 20       |           |          |                |

**NOTE:**

The pulse cycle changes depending on rpm at idle.

Is the inspection result normal?

- YES >> INSPECTION END
- NO >> Go to [EC-952, "Diagnosis Procedure"](#).

Diagnosis Procedure

INFOID:000000007730093

1.CHECK IGNITION COIL POWER SUPPLY CIRCUIT-I

1. Turn ignition switch OFF, wait at least 10 seconds and then turn it ON.
2. Check the voltage between ECM harness connector terminals as per the following.

| ECM       |          |          | Voltage         |
|-----------|----------|----------|-----------------|
| Connector | +        | -        |                 |
|           | Terminal | Terminal |                 |
| M107      | 125      | 128      | Battery voltage |

Is the inspection result normal?

- YES >> GO TO 2.



# IGNITION SIGNAL

[VQ37VHR FOR MEXICO]

< DTC/CIRCUIT DIAGNOSIS >

NO >> Go to [EC-682. "Diagnosis Procedure"](#).

## 2.CHECK IGNITION COIL POWER SUPPLY CIRCUIT-II

1. Turn ignition switch OFF.
2. Disconnect condenser harness connector.
3. Turn ignition switch ON.
4. Check the voltage between condenser harness connector and ground.

| Condenser |          | Ground | Voltage         |
|-----------|----------|--------|-----------------|
| Connector | Terminal |        |                 |
| F8        | 1        | Ground | Battery voltage |

Is the inspection result normal?

YES >> GO TO 5.

NO >> GO TO 3.

## 3.CHECK IGNITION COIL POWER SUPPLY CIRCUIT-III

1. Turn ignition switch OFF.
2. Disconnect IPDM E/R harness connector.
3. Check the continuity between IPDM E/R harness connector and condenser harness connector.

| IPDM E/R  |          | Condenser |          | Continuity |
|-----------|----------|-----------|----------|------------|
| Connector | Terminal | Connector | Terminal |            |
| E5        | 5        | F8        | 1        | Existed    |

4. Also check harness for short to ground and short to power.

Is the inspection result normal?

YES >> Go to [EC-682. "Diagnosis Procedure"](#).

NO >> GO TO 4.

## 4.DETECT MALFUNCTIONING PART

Check the following.

- Harness connectors E20, F40
- Harness for open or short between IPDM E/R and condenser

>> Repair open circuit, short to ground or short to power in harness or connectors.

## 5.CHECK CONDENSER GROUND CIRCUIT FOR OPEN AND SHORT

1. Turn ignition switch OFF.
2. Check the continuity between condenser harness connector and ground.

| Condenser |          | Ground | Continuity |
|-----------|----------|--------|------------|
| Connector | Terminal |        |            |
| F8        | 2        | Ground | Existed    |

3. Also check harness for short to power.

Is the inspection result normal?

YES >> GO TO 6.

NO >> Repair open circuit or short to power in harness or connectors.

## 6.CHECK CONDENSER

Refer to [EC-956. "Component Inspection \(Condenser\)"](#)

Is the inspection result normal?

YES >> GO TO 7.

NO >> Replace condenser.

## 7.CHECK IGNITION COIL POWER SUPPLY CIRCUIT-IV

# IGNITION SIGNAL

[VQ37VHR FOR MEXICO]

## < DTC/CIRCUIT DIAGNOSIS >

1. Reconnect all harness connectors disconnected.
2. Disconnect ignition coil harness connector.
3. Turn ignition switch ON.
4. Check the voltage between ignition coil harness connector and ground.

| Ignition coil |           |          | Ground | Voltage         |
|---------------|-----------|----------|--------|-----------------|
| Cylinder      | Connector | Terminal |        |                 |
| 1             | F11       | 3        | Ground | Battery voltage |
| 2             | F12       | 3        |        |                 |
| 3             | F13       | 3        |        |                 |
| 4             | F14       | 3        |        |                 |
| 5             | F15       | 3        |        |                 |
| 6             | F16       | 3        |        |                 |

Is the inspection result normal?

- YES >> GO TO 9.  
NO >> GO TO 8.

## 8.DETECT MALFUNCTIONING PART

Check the following.

- Harness connector F40, E20
- Harness for open or short between ignition coil and harness connector F40

>> Repair or replace harness or connectors.

## 9.CHECK IGNITION COIL GROUND CIRCUIT FOR OPEN AND SHORT

1. Turn ignition switch OFF.
2. Check the continuity between ignition coil harness connector and ground.

| Ignition coil |           |          | Ground | Continuity |
|---------------|-----------|----------|--------|------------|
| Cylinder      | Connector | Terminal |        |            |
| 1             | F11       | 2        | Ground | Existed    |
| 2             | F12       | 2        |        |            |
| 3             | F13       | 2        |        |            |
| 4             | F14       | 2        |        |            |
| 5             | F15       | 2        |        |            |
| 6             | F16       | 2        |        |            |

3. Also check harness for short to power.

Is the inspection result normal?

- YES >> GO TO 10.  
NO >> Repair open circuit or short to power in harness or connectors.

## 10.CHECK IGNITION COIL OUTPUT SIGNAL CIRCUIT FOR OPEN AND SHORT

1. Disconnect ECM harness connector.
2. Check the continuity between ignition coil harness connector and ECM harness connector.

# IGNITION SIGNAL

< DTC/CIRCUIT DIAGNOSIS >

[VQ37VHR FOR MEXICO]

| Ignition coil |           |          | ECM       |          | Continuity |
|---------------|-----------|----------|-----------|----------|------------|
| Cylinder      | Connector | Terminal | Connector | Terminal |            |
| 1             | F11       | 1        | F101      | 20       | Existed    |
| 2             | F12       | 1        |           | 16       |            |
| 3             | F13       | 1        |           | 12       |            |
| 4             | F14       | 1        |           | 11       |            |
| 5             | F15       | 1        |           | 15       |            |
| 6             | F16       | 1        |           | 19       |            |

3. Also check harness for short to ground and short to power.

Is the inspection result normal?

YES >> GO TO 11.

NO >> Repair open circuit, short to ground or short to power in harness or connectors.

## 11.CHECK IGNITION COIL WITH POWER TRANSISTOR

Refer to [EC-955, "Component Inspection \(Ignition Coil with Power Transistor\)"](#).

Is the inspection result normal?

YES >> GO TO 12.

NO >> Replace malfunctioning ignition coil with power transistor. Refer to [EM-39, "Exploded View"](#).

## 12.CHECK INTERMITTENT INCIDENT

Refer to [GI-44, "Intermittent Incident"](#).

>> INSPECTION END

## Component Inspection (Ignition Coil with Power Transistor)

INFOID:000000007730094

### 1.CHECK IGNITION COIL WITH POWER TRANSISTOR-I

1. Turn ignition switch OFF.
2. Disconnect ignition coil harness connector.
3. Check resistance between ignition coil terminals as per the following.

| Terminals | Resistance ( $\Omega$ ) [at 25°C (77°F)] |
|-----------|--|
| 1 and 2   | Except 0 or $\infty$                     |
| 1 and 3   | Except 0                                 |
| 2 and 3   |  |

Is the inspection result normal?

YES >> GO TO 2.

NO >> Replace malfunctioning ignition coil with power transistor. Refer to [EM-39, "Exploded View"](#).

### 2.CHECK IGNITION COIL WITH POWER TRANSISTOR-II

#### **CAUTION:**

**Perform the following procedure in a place where with no combustible objects and good ventilation.**

1. Turn ignition switch OFF.
2. Reconnect all harness connectors disconnected.

# IGNITION SIGNAL

[VQ37VHR FOR MEXICO]

## < DTC/CIRCUIT DIAGNOSIS >

- Remove fuel pump fuse (1) in IPDM E/R (2) to release fuel pressure.

**NOTE:**

Do not use CONSULT to release fuel pressure, or fuel pressure applies again during the following procedure.

- Start engine.
- After engine stalls, crank it two or three times to release all fuel pressure.
- Turn ignition switch OFF.
- Remove all ignition coil harness connectors to avoid the electrical discharge from the ignition coils.
- Remove ignition coil and spark plug of the cylinder to be checked.
- Crank engine for 5 seconds or more to remove combustion gas in the cylinder.
- Connect spark plug and harness connector to ignition coil.
- Fix ignition coil using a rope etc. with gap of 13 - 17 mm (0.52 - 0.66 in) between the edge of the spark plug and grounded metal portion as shown in the figure.
- Crank engine for about three seconds, and check whether spark is generated between the spark plug and the grounded metal portion.

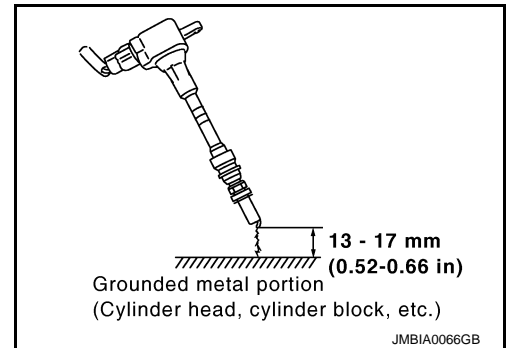
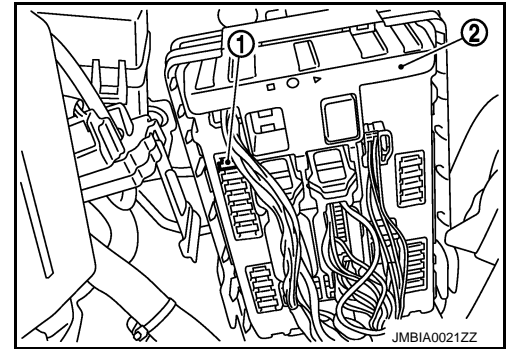

**Spark should be generated.**

**CAUTION:**

- Never place the spark plug and the ignition coil within 50 cm (19.7 in) each other. Be careful not to get an electrical shock while checking, because the electrical discharge voltage becomes 20 kV or more.
- It might damage the ignition coil if the gap of more than 17 mm (0.66 in) is made.

**NOTE:**

When the gap is less than 13 mm (0.52 in), spark might be generated even if the coil is malfunctioning.

Is the inspection result normal?

YES >> INSPECTION END

NO >> Replace malfunctioning ignition coil with power transistor. Refer to [EM-39, "Exploded View"](#).

## Component Inspection (Condenser)

INFOID:000000007730095

### 1. CHECK CONDENSER

- Turn ignition switch OFF.
- Disconnect condenser harness connector.
- Check resistance between condenser terminals as per the following.

| Terminals | Resistance (MΩ)          |
|-----------|--------------------------|
| 1 and 2   | Above 1 [at 25°C (77°F)] |

Is the inspection result normal?

YES >> INSPECTION END

NO >> Replace condenser.

# MALFUNCTION INDICATOR LAMP

< DTC/CIRCUIT DIAGNOSIS >

[VQ37VHR FOR MEXICO]

## MALFUNCTION INDICATOR LAMP

### Component Function Check

INFOID:000000007730096

#### 1.CHECK MIL FUNCTION

1. Turn ignition switch ON.
2. Make sure that MIL illuminates.

Is the inspection result normal?

- YES >> INSPECTION END  
NO >> Go to [EC-957. "Diagnosis Procedure"](#).

### Diagnosis Procedure

INFOID:000000007730097

#### 1.CHECK DTC

Check that DTC UXXXX is not displayed.

Is the inspection result normal?

- YES >> GO TO 2.  
NO >> Perform trouble diagnosis for DTC UXXXX.

#### 2.CHECK DTC WITH "COMBINATION METER"

Refer to [MWI-31. "CONSULT Function"](#).

Is the inspection result normal?

- YES >> GO TO 3.  
NO >> Repair or replace.

#### 3.CHECK INTERMITTENT INCIDENT

Refer to [GI-44. "Intermittent Incident"](#).

Is the inspection result normal?

- YES >> Replace combination meter. Refer to [MWI-79. "Exploded View"](#).  
NO >> Repair or replace.

A  
EC  
C  
D  
E  
F  
G  
H  
I  
J  
K  
L  
M  
N  
O  
P

# MAP (MANIFOLD ABSOLUTE PRESSURE) SENSOR

< DTC/CIRCUIT DIAGNOSIS >

[VQ37VHR FOR MEXICO]

## MAP (MANIFOLD ABSOLUTE PRESSURE) SENSOR

### Component Function Check

INFOID:000000007803066

#### 1. CHECK MAP SENSOR FUNCTION

1. Start engine and warm it up to normal operating temperature.
2. Turn ignition switch OFF, wait at least 5 seconds and then turn ON.
3. Check the voltage between ECM harness connector terminals as follows.

| ECM       |          |           |          |
|-----------|----------|-----------|----------|
| +         |          | -         |          |
| Connector | Terminal | Connector | Terminal |
| F101      | 38       | F102      | 96       |

**NOTE:**

Since this sensor is an absolute pressure sensor and is subject to ambient pressure and altitude, check voltage after a lapse of one minute or more after stopping the engine.

4. Measure the atmospheric pressure.

**NOTE:**

As the atmospheric pressure described on the synoptic chart is the value at sea level, compensate the pressure with the following chart.

| Altitude (m) | Compensated pressure (hPa) |
|--------------|----------------------------|
| 0            | 0                          |
| 200          | -24                        |
| 400          | -47                        |
| 600          | -70                        |
| 800          | -92                        |
| 1000         | -114                       |
| 1500         | -168                       |
| 2000         | -218                       |

5. Check the MAP sensor value corresponding to the atmospheric pressure.

| Atmospheric pressure (hPa) | Voltage (V) |
|----------------------------|-------------|
| 800                        | 3.1 – 3.7   |
| 850                        | 3.3 – 3.9   |
| 900                        | 3.5 – 4.1   |
| 950                        | 3.8 – 4.3   |
| 1000                       | 4.0 – 4.6   |
| 1050                       | 4.2 – 4.8   |

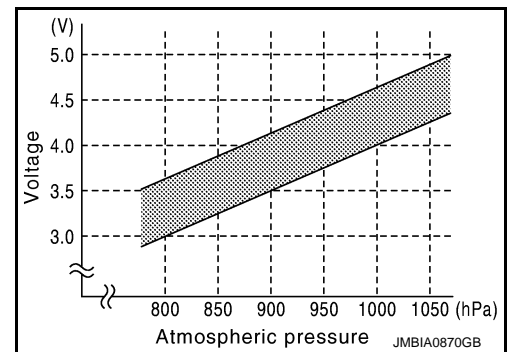

Is the inspection result normal?

YES >> INSPECTION END

NO >> Proceed to [EC-958. "Diagnosis Procedure"](#).

### Diagnosis Procedure

INFOID:000000007803067

#### 1. CHECK MAP SENSOR POWER SUPPLY CIRCUIT-I

1. Disconnect MAP sensor harness connector.
2. Turn ignition switch ON.
3. Check the voltage between MAP sensor harness connector terminals.

# MAP (MANIFOLD ABSOLUTE PRESSURE) SENSOR

< DTC/CIRCUIT DIAGNOSIS >

[VQ37VHR FOR MEXICO]

| MAP sensor |          |   | Voltage<br>(Approx.) |
|------------|----------|---|----------------------|
| Connector  | +        | - |                      |
|            | Terminal |   |                      |
| F50        | 1        | 3 | 5 V                  |

Is the inspection result normal?

- YES >> GO TO 6.
- NO >> GO TO 2.

## 2.CHECK MAP SENSOR POWER SUPPLY CIRCUIT-II

Check the voltage between MAP sensor harness connector and ground.

| +          |          | -      | Voltage<br>(Approx.) |
|------------|----------|--------|----------------------|
| MAP sensor |          |        |                      |
| Connector  | Terminal |        |                      |
| F50        | 1        | Ground | 5 V                  |

Is inspection result normal?

- YES >> GO TO 4.
- NO >> GO TO 3.

## 3.CHECK MAP SENSOR POWER SUPPLY CIRCUIT-III

1. Turn ignition switch OFF.
2. Disconnect ECM harness connector.
3. Check the continuity between MAP sensor harness connector and ECM harness connector.

| +          |          | -         |          | Continuity |
|------------|----------|-----------|----------|------------|
| MAP sensor |          | ECM       |          |            |
| Connector  | Terminal | Connector | Terminal |            |
| F50        | 1        | F102      | 60       | Existed    |

4. Also check harness for short to ground and to power.

Is the inspection result normal?

- YES >> Perform the trouble diagnosis for ignition power supply circuit. Refer to [EC-682. "Diagnosis Procedure"](#).
- NO >> Repair or replace error-detected parts.

## 4.CHECK MAP SENSOR GROUND CIRCUIT

1. Turn ignition switch OFF.
2. Disconnect ECM harness connector.
3. Check the continuity between MAP sensor harness connector and ECM harness connector.

| +          |          | -         |          | Continuity |
|------------|----------|-----------|----------|------------|
| MAP sensor |          | ECM       |          |            |
| Connector  | Terminal | Connector | Terminal |            |
| F50        | 3        | F103      | 96       | Existed    |

Is inspection result normal?

- YES >> GO TO 5.
- NO >> Repair or replace error-detected parts.

## 5.CHECK ECM GROUND CIRCUIT

Check the continuity between ECM harness connector and the ground.

# MAP (MANIFOLD ABSOLUTE PRESSURE) SENSOR

< DTC/CIRCUIT DIAGNOSIS >

[VQ37VHR FOR MEXICO]

| +         |          | -      | Continuity |
|-----------|----------|--------|------------|
| ECM       |          |        |            |
| Connector | Terminal |        |            |
| F101      | 8        | ground | Existed    |
| M107      | 123      |        |            |
|           | 124      |        |            |
|           | 127      |        |            |
|           | 128      |        |            |

Is inspection result normal?

YES >> Check intermittent incident. Refer to [GI-44, "Intermittent Incident"](#).

NO >> Repair or replace error-detected parts.

## 6.CHECK MAP SENSOR INPUT SIGNAL CIRCUIT

1. Check the continuity between MAP sensor harness connector and ECM harness connector.

| +          |          | -         |          | Continuity |
|------------|----------|-----------|----------|------------|
| MAP sensor |          | ECM       |          |            |
| Connector  | Terminal | Connector | Terminal |            |
| F50        | 2        | F101      | 38       | Existed    |

2. Also check harness for short to ground and to power.

Is the inspection result normal?

YES >> GO TO 7.

NO >> Repair or replace error-detected parts.

## 7.CHECK MAP SENSOR

Refer to [EC-960, "Component Inspection"](#).

Is the inspection result normal?

YES >> Check intermittent incident. Refer to [GI-44, "Intermittent Incident"](#).

NO >> Replace MAP sensor. Refer to [EM-31, "Exploded View"](#).

## Component Inspection

INFOID:000000007803068

### 1.CHECK MAP SENSOR

1. Turn ignition switch OFF.
2. Reconnect harness connector disconnected.
3. Start engine and keep the engine speed at idle.
4. Check the voltage between ECM harness connector terminals.

| +         |          | -         |          |
|-----------|----------|-----------|----------|
| ECM       |          |           |          |
| Connector | Terminal | Connector | Terminal |
| F101      | 38       | F102      | 96       |

5. Confirm the difference of the voltage when engine is stopped and at idling is within the values shown in the following chart.

| Intake manifold vacuum [kPa (mmHg)] | Voltage difference (V) |
|-------------------------------------|------------------------|
| -40 (-300)                          | 1.5 – 2.0              |
| -53.3 (-400)                        | 2.0 – 2.6              |



# MAP (MANIFOLD ABSOLUTE PRESSURE) SENSOR

< DTC/CIRCUIT DIAGNOSIS >

[VQ37VHR FOR MEXICO]

| Intake manifold vacuum [kPa (mmHg)] | Voltage difference (V) |
|-------------------------------------|------------------------|
| -66.7 (-500)                        | 2.6 – 3.2              |
| -80 (-600)                          | 3.2 – 3.8              |

Is the inspection result normal?

YES >> INSPECTION END

NO >> Replace MAP sensor. Refer to [EM-31, "Exploded View"](#).

A

EC

C

D

E

F

G

H

I

J

K

L

M

N

O

P

# ON BOARD REFUELING VAPOR RECOVERY (ORVR)

< DTC/CIRCUIT DIAGNOSIS >

[VQ37VHR FOR MEXICO]

## ON BOARD REFUELING VAPOR RECOVERY (ORVR)

### Component Function Check

INFOID:000000007730098

#### 1.CHECK ORVR FUNCTION

Check whether the following symptoms are present.

- Fuel odor from EVAP canister is strong.
- Cannot refuel/Fuel odor from the fuel filler opening is strong while refueling.

Are any symptoms present?

- YES >> Go to [EC-962, "Diagnosis Procedure"](#).  
NO >> INSPECTION END

### Diagnosis Procedure

INFOID:000000007730099

#### 1.INSPECTION START

Check whether the following symptoms are present.

- A: Fuel odor from EVAP canister is strong.  
B: Cannot refuel/Fuel odor from the fuel filler opening is strong while refueling.

Which symptom is present?

- A >> GO TO 2.  
B >> GO TO 7.

#### 2.CHECK EVAP CANISTER

1. Remove EVAP canister with EVAP canister vent control valve and EVAP control system pressure sensor attached.
2. Weigh the EVAP canister with EVAP canister vent control valve and EVAP control system pressure sensor attached.

**The weight should be less than 2.1 kg (4.6 lb).**

Is the inspection result normal?

- YES >> GO TO 3.  
NO >> GO TO 4.

#### 3.CHECK IF EVAP CANISTER IS SATURATED WITH WATER

Check if water will drain from EVAP canister (1).

- 2: EVAP canister vent control valve

Does water drain from the EVAP canister?

- YES >> GO TO 4.  
NO >> GO TO 6.

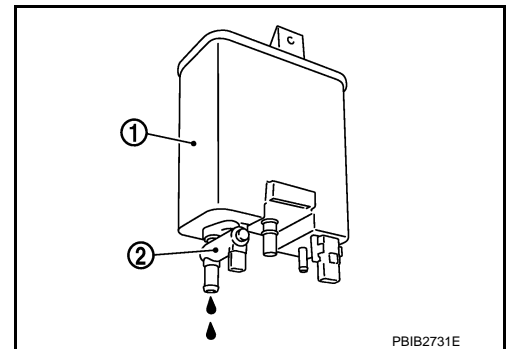

#### 4.REPLACE EVAP CANISTER

Replace EVAP canister with a new one.

>> GO TO 5.

#### 5.DETECT MALFUNCTIONING PART

Check the EVAP hose between EVAP canister and vehicle frame for clogging or poor connection.

>> Repair or replace EVAP hose.

#### 6.CHECK REFUELING EVAP VAPOR CUT VALVE

Refer to [EC-964, "Component Inspection"](#).

# ON BOARD REFUELING VAPOR RECOVERY (ORVR)

[VQ37VHR FOR MEXICO]

< DTC/CIRCUIT DIAGNOSIS >

Is the inspection result normal?

YES >> INSPECTION END

NO >> Replace refueling EVAP vapor cut valve with fuel tank. Refer to [FL-10. "Exploded View"](#).

## 7.CHECK EVAP CANISTER

1. Remove EVAP canister with EVAP canister vent control valve and EVAP control system pressure sensor attached.

2. Weigh the EVAP canister with EVAP canister vent control valve and EVAP control system pressure sensor attached.

**The weight should be less than 2.1 kg (4.6 lb).**

Is the inspection result normal?

YES >> GO TO 8.

NO >> GO TO 9.

## 8.CHECK IF EVAP CANISTER IS SATURATED WITH WATER

Check if water will drain from EVAP canister (1).

2 : EVAP canister vent control valve

Does water drain from the EVAP canister?

YES >> GO TO 9.

NO >> GO TO 11.

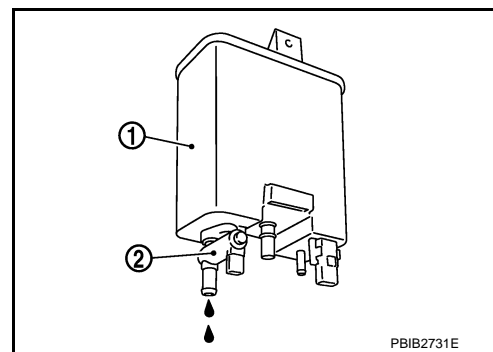

## 9.REPLACE EVAP CANISTER

Replace EVAP canister with a new one.

>> GO TO 10.

## 10.DETECT MALFUNCTIONING PART

Check the EVAP hose between EVAP canister and vehicle frame for clogging or poor connection.

>> Repair or replace EVAP hose.

## 11.CHECK VENT HOSES AND VENT TUBES

Check hoses and tubes between EVAP canister and refueling control valve for clogging, kinks, looseness and improper connection.

Is the inspection result normal?

YES >> GO TO 12.

NO >> Repair or replace hoses and tubes.

## 12.CHECK FILLER NECK TUBE

Check recirculation line for clogging, dents and cracks.

Is the inspection result normal?

YES >> GO TO 13.

NO >> Replace filler neck tube.

## 13.CHECK REFUELING EVAP VAPOR CUT VALVE

Refer to [EC-964. "Component Inspection"](#).

Is the inspection result normal?

YES >> GO TO 14.

NO >> Replace refueling EVAP vapor cut valve with fuel tank. Refer to [FL-10. "Exploded View"](#).

## 14.CHECK FUEL FILLER TUBE

Check filler neck tube and hose connected to the fuel tank for clogging, dents and cracks.

# ON BOARD REFUELING VAPOR RECOVERY (ORVR)

[VQ37VHR FOR MEXICO]

< DTC/CIRCUIT DIAGNOSIS >

Is the inspection result normal?

YES >> GO TO 15.

NO >> Replace fuel filler tube. Refer to [FL-10, "Exploded View"](#).

## 15.CHECK ONE-WAY FUEL VALVE-I

Check one-way valve for clogging.

Is the inspection result normal?

YES >> GO TO 16.

NO >> Repair or replace one-way fuel valve with fuel tank. Refer to [FL-10, "Exploded View"](#).

## 16.CHECK ONE-WAY FUEL VALVE-II

1. Make sure that fuel is drained from the tank.
2. Remove fuel filler tube and hose.
3. Check one-way fuel valve for operation as follows.  
When a stick is inserted, the valve should open, when removing stick it should close.

**Do not drop any material into the tank.**

Is the inspection result normal?

YES >> INSPECTION END

NO >> Replace fuel filler tube or replace one-way fuel valve with fuel tank. Refer to [FL-10, "Exploded View"](#).

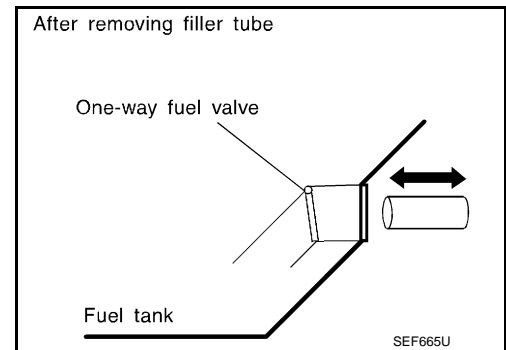

INFOID:000000007730100

## Component Inspection

### 1.INSPECTION START

Do you have CONSULT?

Do you have CONSULT?

YES >> GO TO 2.

NO >> GO TO 3.

### 2.CHECK REFUELING EVAP VAPOR CUT VALVE

**ⓅWith CONSULT**

1. Turn ignition switch OFF.
2. Remove fuel tank. Refer to [FL-10, "Removal and Installation"](#).
3. Drain fuel from the tank as follows:
  - Remove fuel feed hose located on the fuel gauge retainer.
  - Connect a spare fuel hose, one side to fuel gauge retainer where the hose was removed and the other side to a fuel container.
  - Drain fuel using "FUEL PUMP RELAY" in "ACTIVE TEST" mode with CONSULT.
4. Check refueling EVAP vapor cut valve for being stuck to close as follows.  
Blow air into the refueling EVAP vapor cut valve (from the end of EVAP/ORVR line hose), and check that the air flows freely into the tank.
5. Check refueling EVAP vapor cut valve for being stuck to open as follows.
  - Connect vacuum pump to hose end.
  - Remove fuel gauge retainer with fuel gauge unit.

**Always replace O-ring with new one.**

  - Turn fuel tank upside down.

# ON BOARD REFUELING VAPOR RECOVERY (ORVR)

[VQ37VHR FOR MEXICO]

## < DTC/CIRCUIT DIAGNOSIS >

- Apply vacuum pressure to hose end [-13.3 kPa (-0.136 kg/cm<sup>3</sup>, -1.93 psi)] with fuel gauge retainer remaining open and check that the pressure is applicable.

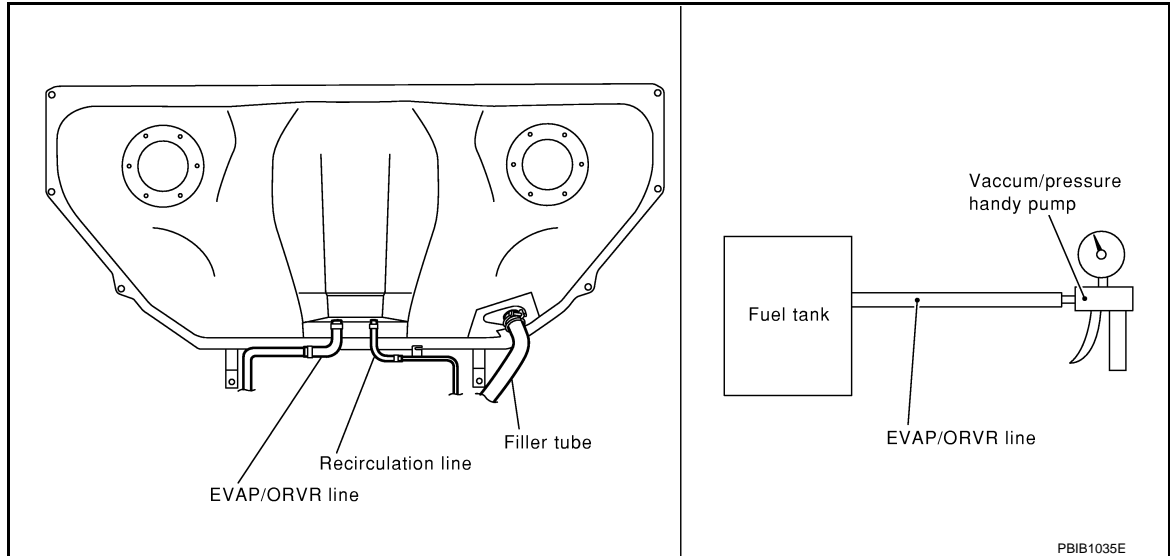

Is the inspection result normal?

YES >> INSPECTION END

NO >> Replace refueling EVAP vapor cut valve with fuel tank.

## 3. CHECK REFUELING EVAP VAPOR CUT VALVE

### ⊗ Without CONSULT

1. Turn ignition switch OFF.
  2. Remove fuel tank. Refer to [FL-10. "Removal and Installation"](#).
  3. Drain fuel from the tank as follows:
    - Remove fuel gauge retainer.
    - Drain fuel from the tank using a handy pump into a fuel container.
  4. Check refueling EVAP vapor cut valve for being stuck to close as follows.  
Blow air into the refueling EVAP vapor cut valve (from the end of EVAP/ORVR line hose), and check that the air flows freely into the tank.
  5. Check refueling EVAP vapor cut valve for being stuck to open as follows.
    - Connect vacuum pump to hose end.
    - Remove fuel gauge retainer with fuel gauge unit.
- Always replace O-ring with new one.**
- Turn fuel tank upside down.
  - Apply vacuum pressure to hose end [-13.3 kPa (-0.136 kg/cm<sup>3</sup>, -1.93 psi)] with fuel gauge retainer remaining open and check that the pressure is applicable.

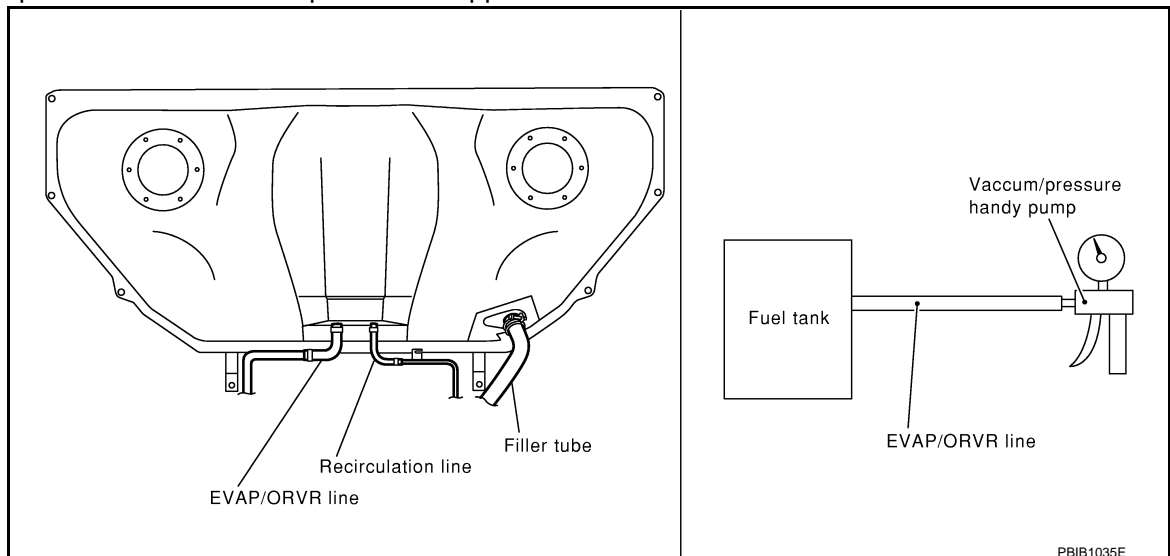

## ON BOARD REFUELING VAPOR RECOVERY (ORVR)

< DTC/CIRCUIT DIAGNOSIS >

[VQ37VHR FOR MEXICO]

---

Is the inspection result normal?

YES >> INSPECTION END

NO >> Replace refueling EVAP vapor cut valve with fuel tank. Refer to [FL-10. "Exploded View"](#).

# REFRIGERANT PRESSURE SENSOR

< DTC/CIRCUIT DIAGNOSIS >

[VQ37VHR FOR MEXICO]

## REFRIGERANT PRESSURE SENSOR

### Component Function Check

INFOID:000000007730101

#### 1. CHECK REFRIGERANT PRESSURE SENSOR FUNCTION

1. Start engine and warm it up to normal operating temperature.
2. Turn A/C switch and blower fan switch ON.
3. Check the voltage between ECM harness connector terminals as per the following.

| Connector | ECM   |          | Voltage (V) |
|-----------|---|----------|-------------|
|           | +   | -        |             |
|           | Terminal                                    | Terminal |             |
| M107      | 105<br>(Refrigerant pressure sensor signal) | 112      | 1.0 - 4.0   |

Is the inspection result normal?

- YES >> INSPECTION END  
NO >> Go to [EC-967, "Diagnosis Procedure"](#).

### Diagnosis Procedure

INFOID:000000007730102

#### 1. CHECK GROUND CONNECTION

1. Turn A/C switch and blower fan switch OFF.
2. Turn ignition switch OFF.
3. Check ground connection M95. Refer to Ground Inspection in [GI-47, "Circuit Inspection"](#).

Is the inspection result normal?

- YES >> GO TO 2.  
NO >> Repair or replace ground connection.

#### 2. CHECK REFRIGERANT PRESSURE SENSOR POWER SUPPLY CIRCUIT

1. Disconnect refrigerant pressure sensor harness connector.
2. Turn ignition switch ON.
3. Check the voltage between refrigerant pressure sensor harness connector and ground.

| Refrigerant pressure sensor |          | Ground | Voltage (V) |
|-----------------------------|----------|--------|-------------|
| Connector                   | Terminal |        |             |
| E77                         | 3        | Ground | Approx. 5   |

Is the inspection result normal?

- YES >> GO TO 4.  
NO >> GO TO 3.

#### 3. DETECT MALFUNCTIONING PART

Check the following.

- Harness connectors M6, E106
- Harness for open or short between ECM and refrigerant pressure sensor

>> Repair open circuit, short to ground or short to power in harness or connectors.

#### 4. CHECK REFRIGERANT PRESSURE SENSOR GROUND CIRCUIT FOR OPEN AND SHORT

1. Turn ignition switch OFF.
2. Disconnect ECM harness connector.
3. Check the continuity between refrigerant pressure sensor harness connector and ECM harness connector.

# REFRIGERANT PRESSURE SENSOR

< DTC/CIRCUIT DIAGNOSIS >

[VQ37VHR FOR MEXICO]

| Refrigerant pressure sensor |          | ECM       |          | Continuity |
|-----------------------------|----------|-----------|----------|------------|
| Connector                   | Terminal | Connector | Terminal |            |
| E77                         | 1        | M107      | 112      | Existed    |

4. Also check harness for short to ground and short to power.

Is the inspection result normal?

- YES >> GO TO 6.
- NO >> GO TO 5.

## 5. DETECT MALFUNCTIONING PART

Check the following.

- Harness connectors M6, E106
- Harness for open or short between ECM and refrigerant pressure sensor

>> Repair open circuit, short to ground or short to power in harness or connectors.

## 6. CHECK REFRIGERANT PRESSURE SENSOR INPUT SIGNAL CIRCUIT FOR OPEN AND SHORT

1. Check the continuity between refrigerant pressure sensor harness connector and ECM harness connector.

| Refrigerant pressure sensor |          | ECM       |          | Continuity |
|-----------------------------|----------|-----------|----------|------------|
| Connector                   | Terminal | Connector | Terminal |            |
| E77                         | 2        | M107      | 105      | Existed    |

2. Also check harness for short to ground and short to power.

Is the inspection result normal?

- YES >> GO TO 8.
- NO >> GO TO 7.

## 7. DETECT MALFUNCTIONING PART

Check the following.

- Harness connectors M6, E106
- Harness for open or short between ECM and refrigerant pressure sensor

>> Repair open circuit, short to ground or short to power in harness or connectors.

## 8. CHECK INTERMITTENT INCIDENT

Refer to [GI-44, "Intermittent Incident"](#).

Is the inspection result normal?

- YES >> Replace refrigerant pressure sensor. Refer to [HA-39, "Exploded View"](#).
- NO >> Repair or replace.



# ENGINE CONTROL SYSTEM SYMPTOMS

< SYMPTOM DIAGNOSIS >

[VQ37VHR FOR MEXICO]

## SYMPTOM DIAGNOSIS

### ENGINE CONTROL SYSTEM SYMPTOMS

#### Symptom Table

INFOID:000000007730103

#### SYSTEM — BASIC ENGINE CONTROL SYSTEM

|   |                                       | SYMPTOM                          |              |                              |                        |                                 |                    |                    |                  |                        |                                  |                            |                           | Reference page |  |
|---|---------------------------------------|----------------------------------|--------------|------------------------------|------------------------|---------------------------------|--------------------|--------------------|------------------|------------------------|----------------------------------|----------------------------|---------------------------|----------------|--|
|   |                                       | HARD/NO START/RESTART (EXCP. HA) | ENGINE STALL | HESITATION/SURGING/FLAT SPOT | SPARK KNOCK/DETONATION | LACK OF POWER/POOR ACCELERATION | HIGH IDLE/LOW IDLE | ROUGH IDLE/HUNTING | IDLING VIBRATION | SLOW/NO RETURN TO IDLE | OVERHEATS/WATER TEMPERATURE HIGH | EXCESSIVE FUEL CONSUMPTION | EXCESSIVE OIL CONSUMPTION |                | BATTERY DEAD (UNDER CHARGE)  |
| Warranty symptom code                     |                                       | AA                               | AB           | AC                           | AD                     | AE                              | AF                 | AG                 | AH               | AJ                     | AK                               | AL                         | AM                        | HA             |  |
| Fuel                                      | Fuel pump circuit                     | 1                                | 1            | 2                            | 3                      | 2                               |                    | 2                  | 2                |                        |                                  | 3                          |                           | 2              | <a href="#">EC-947</a>   |
|   | Fuel pressure regulator system        | 3                                | 3            | 4                            | 4                      | 4                               | 4                  | 4                  | 4                | 4                      |                                  | 4                          |                           |                | <a href="#">EC-667</a>   |
|   | Fuel injector circuit                 | 1                                | 1            | 2                            | 3                      | 2                               |                    | 2                  | 2                |                        |                                  | 2                          |                           |                | <a href="#">EC-945</a>   |
|   | Evaporative emission system           | 3                                | 3            | 4                            | 4                      | 4                               | 4                  | 4                  | 4                | 4                      | 4                                | 4                          |                           |                | <a href="#">EC-580</a>   |
| Air                                       | Positive crankcase ventilation system | 3                                | 3            | 4                            | 4                      | 4                               | 4                  | 4                  | 4                | 4                      | 4                                | 4                          | 1                         |                | <a href="#">EC-979</a>   |
|   | Incorrect idle speed adjustment       |                                  |              |                              |                        |                                 | 1                  | 1                  | 1                | 1                      |                                  | 1                          |                           |                | <a href="#">EC-663</a>   |
|   | Electric throttle control actuator    | 1                                | 1            | 2                            | 3                      | 3                               | 2                  | 2                  | 2                | 2                      |                                  | 2                          |                           | 2              | <a href="#">EC-853</a> ,<br><a href="#">EC-860</a>   |
| Ignition                                  | Incorrect ignition timing adjustment  | 3                                | 3            | 1                            | 1                      | 1                               |                    | 1                  | 1                |                        |                                  | 1                          |                           |                | <a href="#">EC-663</a>   |
|   | Ignition circuit                      | 1                                | 1            | 2                            | 2                      | 2                               |                    | 2                  | 2                |                        |                                  | 2                          |                           |                | <a href="#">EC-952</a>   |
| Main power supply and ground circuit      |                                       | 2                                | 2            | 3                            | 3                      | 3                               |                    | 3                  | 3                |                        | 2                                | 3                          |                           |                | <a href="#">EC-682</a>   |
| Mass air flow sensor circuit              |                                       | 1                                |              |                              | 2                      |                                 |                    |                    |                  |                        |                                  |                            |                           |                | <a href="#">EC-706</a>   |
| Engine coolant temperature sensor circuit |                                       |                                  |              |                              | 3                      |                                 |                    |                    |                  |                        |                                  |                            |                           |                |  |
| Air fuel ratio (A/F) sensor 1 circuit     |                                       |                                  | 1            | 2                            | 3                      | 2                               |                    | 2                  | 2                |                        |                                  | 2                          |                           |                | <a href="#">EC-719</a> ,<br><a href="#">EC-723</a> ,<br><a href="#">EC-726</a> ,<br><a href="#">EC-729</a> ,<br><a href="#">EC-932</a> |
| Throttle position sensor circuit          |                                       |                                  |              |                              |                        |                                 |                    |                    |                  |                        |                                  |                            |                           |                |  |
| Accelerator pedal position sensor circuit |                                       |                                  |              | 3                            | 2                      | 1                               |                    |                    |                  |                        |                                  |                            |                           |                | <a href="#">EC-918</a> ,<br><a href="#">EC-922</a> ,<br><a href="#">EC-927</a>   |
| Knock sensor circuit                      |                                       |                                  |              | 2                            |                        |                                 |                    |                    |                  |                        |                                  | 3                          |                           |                | <a href="#">EC-776</a>   |
| Engine oil temperature sensor             |                                       |                                  |              | 4                            |                        | 1                               |                    |                    |                  |                        |                                  | 3                          |                           |                | <a href="#">EC-765</a>   |

# ENGINE CONTROL SYSTEM SYMPTOMS

< SYMPTOM DIAGNOSIS >

[VQ37VHR FOR MEXICO]

|  | SYMPTOM                          |              |                              |                        |                                 |                    |                    |                  |                        |                                  |                            |                           | Reference<br>page |  |
|--|----------------------------------|--------------|------------------------------|------------------------|---------------------------------|--------------------|--------------------|------------------|------------------------|----------------------------------|----------------------------|---------------------------|-------------------|--|
|  | HARD/NO START/RESTART (EXCP. HA) | ENGINE STALL | HESITATION/SURGING/FLAT SPOT | SPARK KNOCK/DETONATION | LACK OF POWER/POOR ACCELERATION | HIGH IDLE/LOW IDLE | ROUGH IDLE/HUNTING | IDLING VIBRATION | SLOW/NO RETURN TO IDLE | OVERHEATS/WATER TEMPERATURE HIGH | EXCESSIVE FUEL CONSUMPTION | EXCESSIVE OIL CONSUMPTION |                   | BATTERY DEAD (UNDER CHARGE)                        |
| Warranty symptom code                              | AA                               | AB           | AC                           | AD                     | AE                              | AF                 | AG                 | AH               | AJ                     | AK                               | AL                         | AM                        | HA                |  |
| Crankshaft position sensor (POS) circuit           | 2                                | 2            |                              |                        |                                 |                    |                    |                  |                        |                                  |                            |                           |                   | <a href="#">EC-779</a>                             |
| Camshaft position sensor (PHASE) circuit           | 3                                | 2            |                              |                        |                                 |                    |                    |                  |                        |                                  |                            |                           |                   | <a href="#">EC-783</a>                             |
| Vehicle speed signal circuit                       |                                  | 2            | 3                            |                        | 3                               |                    |                    |                  |                        |                                  | 3                          |                           |                   | <a href="#">EC-810</a>                             |
| Power steering pressure sensor circuit             |                                  | 2            |                              |                        |                                 |                    | 3                  | 3                |                        |                                  |                            |                           |                   | <a href="#">EC-815</a>                             |
| ECM  | 2                                | 2            | 3                            | 3                      | 3                               | 3                  | 3                  | 3                | 3                      | 3                                | 3                          |                           |                   | <a href="#">EC-817</a> ,<br><a href="#">EC-819</a> |
| Intake valve timing control solenoid valve circuit |                                  | 3            | 2                            |                        | 1                               | 3                  | 2                  | 2                | 3                      |                                  | 3                          |                           |                   | <a href="#">EC-703</a>                             |
| Manifold absolute pressure (MAP) sensor            |                                  |              |                              |                        |                                 |                    |                    |                  |                        |                                  | 3                          |                           |                   | <a href="#">EC-958</a>                             |
| VVEL control module                                | 3                                |              | 4                            | 4                      | 3                               |                    |                    |                  |                        |                                  |                            |                           |                   | <a href="#">EC-910</a> ,<br><a href="#">EC-911</a> |
| VVEL actuator motor                                | 3                                |              | 4                            | 4                      | 3                               |                    |                    |                  |                        |                                  |                            |                           |                   | <a href="#">EC-836</a>                             |
| VVEL actuator motor relay                          | 3                                |              | 4                            | 4                      | 3                               |                    |                    |                  |                        |                                  |                            |                           |                   | <a href="#">EC-840</a>                             |
| VVEL actuator shaft position sensor                | 3                                |              | 4                            | 4                      | 3                               |                    |                    |                  |                        |                                  |                            |                           |                   | <a href="#">EC-833</a>                             |
| PNP signal circuit                                 |                                  |              | 3                            |                        | 3                               |                    | 3                  | 3                |                        |                                  | 3                          |                           |                   | <a href="#">EC-825</a>                             |
| Refrigerant pressure sensor circuit                |                                  | 2            |                              |                        |                                 | 3                  |                    |                  | 3                      |                                  | 4                          |                           |                   | <a href="#">EC-967</a>                             |
| Electrical load signal circuit                     |                                  |              |                              |                        |                                 |                    | 3                  |                  |                        |                                  |                            |                           |                   | <a href="#">EC-943</a>                             |
| Air conditioner circuit                            | 2                                | 2            | 3                            | 3                      | 3                               | 3                  | 3                  | 3                | 3                      |                                  | 3                          |                           | 2                 | <a href="#">HAC-68</a>                             |
| ABS actuator and electric unit (control unit)      |                                  |              | 4                            |                        |                                 |                    |                    |                  |                        |                                  |                            |                           |                   | <a href="#">BRC-55</a>                             |

1 - 6: The numbers refer to the order of inspection.

(continued on next page)

## SYSTEM — ENGINE MECHANICAL & OTHER

# ENGINE CONTROL SYSTEM SYMPTOMS

< SYMPTOM DIAGNOSIS >

[VQ37VHR FOR MEXICO]

|                       |   | SYMPTOM                          |              |                              |                        |                                 |                    |                    |                  |                        |                                  |                            |                           | Reference<br>page                                 |                             |   |   |   |  |   |   |  |  |   |   |                        |  |
|-----------------------|---|----------------------------------|--------------|------------------------------|------------------------|---------------------------------|--------------------|--------------------|------------------|------------------------|----------------------------------|----------------------------|---------------------------|---|-----------------------------|---|---|---|--|---|---|--|--|---|---|------------------------|--|
|                       |   | HARD/NO START/RESTART (EXCP. HA) | ENGINE STALL | HESITATION/SURGING/FLAT SPOT | SPARK KNOCK/DETONATION | LACK OF POWER/POOR ACCELERATION | HIGH IDLE/LOW IDLE | ROUGH IDLE/HUNTING | IDLING VIBRATION | SLOW/NO RETURN TO IDLE | OVERHEATS/WATER TEMPERATURE HIGH | EXCESSIVE FUEL CONSUMPTION | EXCESSIVE OIL CONSUMPTION |   | BATTERY DEAD (UNDER CHARGE) |   |   |   |  |   |   |  |  |   |   |                        |  |
| Warranty symptom code |   | AA                               | AB           | AC                           | AD                     | AE                              | AF                 | AG                 | AH               | AJ                     | AK                               | AL                         | AM                        | HA  |                             |   |   |   |  |   |   |  |  |   |   |                        |  |
| Fuel                  | Fuel tank   | 5                                | 5            |                              |                        |                                 |                    |                    |                  |                        |                                  |                            |                           | <a href="#">FL-12</a>                             |                             |   |   |   |  |   |   |  |  |   |   |                        |  |
|                       | Fuel piping   |                                  |              | 5                            | 5                      | 5                               |                    | 5                  | 5                |                        | 5                                |                            |                           | <a href="#">EM-48</a>                             |                             |   |   |   |  |   |   |  |  |   |   |                        |  |
|                       | Vapor lock  |                                  |              |                              |                        |                                 |                    |                    |                  |                        |                                  |                            |                           |   | —                           |   |   |   |  |   |   |  |  |   |   |                        |  |
|                       | Valve deposit   |                                  |              |                              |                        |                                 |                    |                    |                  |                        |                                  |                            |                           |   | —                           |   |   |   |  |   |   |  |  |   |   |                        |  |
|                       | Poor fuel (Heavy weight gasoline, Low octane)   | 5                                |              |                              | 5                      | 5                               | 5                  |                    | 5                | 5                      |                                  |                            | 5                         |   | —                           |   |   |   |  |   |   |  |  |   |   |                        |  |
| Air                   | Air duct  |                                  |              |                              |                        |                                 |                    |                    |                  |                        |                                  |                            |                           | <a href="#">EM-30</a>                             |                             |   |   |   |  |   |   |  |  |   |   |                        |  |
|                       | Air cleaner   |                                  |              |                              |                        |                                 |                    |                    |                  |                        |                                  |                            |                           | <a href="#">EM-30</a>                             |                             |   |   |   |  |   |   |  |  |   |   |                        |  |
|                       | Air leakage from air duct (Mass air flow sensor — electric throttle control actuator) | 5                                | 5            | 5                            |                        | 5                               |                    | 5                  | 5                |                        |                                  | 5                          |                           | <a href="#">EM-30</a>                             |                             |   |   |   |  |   |   |  |  |   |   |                        |  |
|                       | Electric throttle control actuator  |                                  |              | 5                            |                        | 5                               |                    |                    | 5                |                        |                                  |                            |                           | <a href="#">EM-31</a>                             |                             |   |   |   |  |   |   |  |  |   |   |                        |  |
|                       | Air leakage from intake manifold/Collector/Gasket                                     |                                  |              |                              |                        |                                 |                    |                    |                  |                        |                                  |                            |                           |   | <a href="#">EM-35</a>       |   |   |   |  |   |   |  |  |   |   |                        |  |
|                       |   |                                  |              |                              |                        |                                 |                    |                    |                  |                        |                                  |                            |                           |   |                             |   |   |   |  |   |   |  |  |   |   |                        |  |
|                       |   |                                  |              |                              |                        |                                 |                    |                    |                  |                        |                                  |                            |                           |   |                             |   |   |   |  |   |   |  |  |   |   |                        |  |
| Cranking              | Battery   |                                  |              |                              |                        |                                 |                    |                    |                  |                        |                                  |                            |                           | <a href="#">PG-142</a>                            |                             |   |   |   |  |   |   |  |  |   |   |                        |  |
|                       | Generator circuit   | 1                                | 1            | 1                            |                        | 1                               |                    | 1                  | 1                |                        |                                  |                            | 1                         | <a href="#">CHG-14,</a><br><a href="#">CHG-15</a> |                             |   |   |   |  |   |   |  |  |   |   |                        |  |
|                       | Starter circuit   | 3                                |              |                              |                        |                                 |                    |                    |                  |                        |                                  | 1                          |                           | <a href="#">STR-18</a>                            |                             |   |   |   |  |   |   |  |  |   |   |                        |  |
|                       | Signal plate  | 6                                |              |                              |                        |                                 |                    |                    |                  |                        |                                  |                            |                           | <a href="#">EM-132</a>                            |                             |   |   |   |  |   |   |  |  |   |   |                        |  |
|                       | PNP signal circuit  | 4                                |              |                              |                        |                                 |                    |                    |                  |                        |                                  |                            |                           | <a href="#">TM-102</a>                            |                             |   |   |   |  |   |   |  |  |   |   |                        |  |
| Engine                | Cylinder head   | 5                                | 5            | 5                            | 5                      | 5                               | 5                  | 5                  | 5                | 5                      | 5                                | 5                          | 5                         | 5   | <a href="#">EM-119</a>      |   |   |   |  |   |   |  |  |   |   |                        |  |
|                       | Cylinder head gasket  |                                  |              |                              |                        |                                 |                    |                    |                  |                        |                                  |                            |                           |   |                             | 4 | 3 |   |  |   |   |  |  |   |   |                        |  |
|                       | Cylinder block  |                                  |              |                              |                        |                                 |                    |                    |                  |                        |                                  |                            |                           |   |                             |   |   |   |  |   |   |  |  |   |   |                        |  |
|                       | Piston  |                                  |              |                              |                        |                                 |                    |                    |                  |                        |                                  |                            |                           |   |                             |   |   |   |  |   |   |  |  |   | 4 |                        |  |
|                       | Piston ring   |                                  |              |                              |                        |                                 |                    |                    |                  |                        |                                  |                            |                           |   |                             |   |   |   |  |   |   |  |  |   |   |                        |  |
|                       | Connecting rod  | 6                                |              |                              |                        |                                 |                    |                    |                  |                        |                                  |                            |                           |   | 6                           | 6 | 6 | 6 |  | 6 | 6 |  |  | 6 |   | <a href="#">EM-132</a> |  |
|                       | Bearing   |                                  |              |                              |                        |                                 |                    |                    |                  |                        |                                  |                            |                           |   |                             |   |   |   |  |   |   |  |  |   |   |                        |  |
|                       | Crankshaft  |                                  |              |                              |                        |                                 |                    |                    |                  |                        |                                  |                            |                           |   |                             |   |   |   |  |   |   |  |  |   |   |                        |  |
| Valve mechanism       | Timing chain  |                                  |              |                              |                        |                                 |                    |                    |                  |                        |                                  |                            |                           |   | <a href="#">EM-67</a>       |   |   |   |  |   |   |  |  |   |   |                        |  |
|                       | Camshaft  |                                  |              |                              |                        |                                 |                    |                    |                  |                        |                                  |                            |                           |   | <a href="#">EM-106</a>      |   |   |   |  |   |   |  |  |   |   |                        |  |
|                       | Intake valve timing control   | 5                                | 5            | 5                            | 5                      | 5                               |                    | 5                  | 5                |                        |                                  | 5                          |                           | <a href="#">EM-67</a>                             |                             |   |   |   |  |   |   |  |  |   |   |                        |  |
|                       | Intake valve  |                                  |              |                              |                        |                                 |                    |                    |                  |                        |                                  |                            |                           |   |                             |   |   |   |  |   |   |  |  |   |   |                        |  |
|                       | Exhaust valve   |                                  |              |                              |                        |                                 |                    |                    |                  |                        |                                  |                            | 3                         | <a href="#">EM-119</a>                            |                             |   |   |   |  |   |   |  |  |   |   |                        |  |

A  
EC  
C  
D  
E  
F  
G  
H  
I  
J  
K  
L  
M  
N  
O  
P

# ENGINE CONTROL SYSTEM SYMPTOMS

< SYMPTOM DIAGNOSIS >

[VQ37VHR FOR MEXICO]

|   |  | SYMPTOM                          |              |                              |                        |                                 |                    |                    |                  |                        |                                  |                            |                           | Reference<br>page |  |
|---|--|----------------------------------|--------------|------------------------------|------------------------|---------------------------------|--------------------|--------------------|------------------|------------------------|----------------------------------|----------------------------|---------------------------|-------------------|--|
|   |  | HARD/NO START/RESTART (EXCP. HA) | ENGINE STALL | HESITATION/SURGING/FLAT SPOT | SPARK KNOCK/DETONATION | LACK OF POWER/POOR ACCELERATION | HIGH IDLE/LOW IDLE | ROUGH IDLE/HUNTING | IDLING VIBRATION | SLOW/NO RETURN TO IDLE | OVERHEATS/WATER TEMPERATURE HIGH | EXCESSIVE FUEL CONSUMPTION | EXCESSIVE OIL CONSUMPTION |                   | BATTERY DEAD (UNDER CHARGE)  |
| Warranty symptom code                             |  | AA                               | AB           | AC                           | AD                     | AE                              | AF                 | AG                 | AH               | AJ                     | AK                               | AL                         | AM                        | HA                |  |
| Exhaust   | Exhaust manifold/Tube/Muffler/Gasket                 | 5                                | 5            | 5                            | 5                      | 5                               |                    | 5                  | 5                |                        |                                  | 5                          |                           |                   | <a href="#">EM-38</a> ,<br><a href="#">EX-4</a>                          |
|   | Three way catalyst                                   |                                  |              |                              |                        |                                 |                    |                    |                  |                        |                                  |                            |                           |                   |  |
| Lubrica-<br>tion                                  | Oil pan/Oil strainer/Oil pump/Oil filter/Oil gallery | 5                                | 5            | 5                            | 5                      | 5                               |                    | 5                  | 5                |                        |                                  | 5                          |                           |                   | <a href="#">EM-48</a> ,<br><a href="#">LU-11</a> , <a href="#">LU-15</a> |
|   | Oil level (Low)/Filthy oil                           |                                  |              |                              |                        |                                 |                    |                    |                  |                        |                                  |                            |                           |                   | <a href="#">LU-7</a>   |
| Cooling   | Radiator/Hose/Radiator filler cap                    |                                  |              |                              |                        |                                 |                    |                    |                  |                        |                                  |                            |                           |                   | <a href="#">CO-12</a> ,<br><a href="#">CO-12</a>                         |
|   | Thermostat   |                                  |              |                              |                        |                                 |                    |                    |                  | 5                      |                                  |                            |                           |                   | <a href="#">CO-24</a>  |
|   | Water pump   |                                  |              |                              |                        |                                 |                    |                    |                  |                        |                                  |                            |                           |                   | <a href="#">CO-22</a>  |
|   | Water gallery  | 5                                | 5            | 5                            | 5                      | 5                               |                    | 5                  | 5                |                        | 4                                | 5                          |                           |                   | <a href="#">CO-26</a>  |
|   | Cooling fan  |                                  |              |                              |                        |                                 |                    |                    |                  |                        |                                  |                            |                           |                   | <a href="#">CO-19</a>  |
|   | Coolant level (Low)/Contaminated coolant             |                                  |              |                              |                        |                                 |                    |                    |                  |                        | 5                                |                            |                           |                   | <a href="#">CO-8</a>   |
| IVIS (INFINITI Vehicle Immobilizer System — NATS) |  | 1                                | 1            |                              |                        |                                 |                    |                    |                  |                        |                                  |                            |                           |                   | <a href="#">SEC-36</a>   |

1 - 6: The numbers refer to the order of inspection.

# INFINITI DRIVE MODE SELECTOR

< SYMPTOM DIAGNOSIS >

[VQ37VHR FOR MEXICO]

## INFINITI DRIVE MODE SELECTOR

### Symptom Table

INFOID:000000007730104

#### SYSTEM - DRIVE MODE SELECTOR -

| Malfunction  | Check item   |  | Probable malfunctioning part/Action   |
|--|--|--|---|
| ECO pedal reaction force is not generated when in ECO mode.  | Only ECO pedal reaction force is not generated. [Intelligent pedal (distance control assist) operates normally.] | The central switch of the navigation system operates normally. | Perform self-diagnosis of the engine control system. Refer to <a href="#">EC-628, "DTC Index"</a> .   |
|  |  | The central switch of the navigation system malfunctions.      | Perform self-diagnosis of the navigation system. Refer to <a href="#">AV-97, "Symptom Table"</a> (BASE AUDIO WITHOUT NAVIGATION) or <a href="#">AV-252, "Symptom Table"</a> (BOSE AUDIO WITH NAVIGATION)  |
|  | Intelligent pedal (distance control assist) reaction force is not generated as well.                             |  | Perform self-diagnosis of the ADAS control unit, ICC sensor, and Accelerator pedal actuator. <ul style="list-style-type: none"> <li>• ADAS C/U: Refer to <a href="#">DAS-40, "DTC Index"</a>.</li> <li>• ICC SENSOR: Refer to <a href="#">DAS-98, "DTC Index"</a>.</li> <li>• ACCELERATOR PEDAL ACTUATOR: Refer to <a href="#">DAS-101, "DTC Index"</a>.</li> </ul> |
| When in ECO mode, settings of ECO pedal reaction force cannot be changed or vehicle behavior does not agree to the settings. | Intelligent pedal (distance control assist) reaction force has a malfunction as well.                            |  | Perform self-diagnosis of the ADAS control unit, ICC sensor, and Accelerator pedal actuator. <ul style="list-style-type: none"> <li>• ADAS C/U: Refer to <a href="#">DAS-40, "DTC Index"</a>.</li> <li>• ICC SENSOR: Refer to <a href="#">DAS-98, "DTC Index"</a>.</li> <li>• ACCELERATOR PEDAL ACTUATOR: Refer to <a href="#">DAS-101, "DTC Index"</a>.</li> </ul> |
|  | Intelligent pedal (distance control assist) reaction force is normal.  | The central switch of the navigation system operates normally. | Perform self-diagnosis of the engine control system. Refer to <a href="#">EC-628, "DTC Index"</a> .   |
|  |  | The central switch of the navigation system malfunctions.      | Perform self-diagnosis of the navigation system. Refer to <a href="#">AV-97, "Symptom Table"</a> (BASE AUDIO WITHOUT NAVIGATION) or <a href="#">AV-252, "Symptom Table"</a> (BOSE AUDIO WITH NAVIGATION)  |

A  
EC  
C  
D  
E  
F  
G  
H  
I  
J  
K  
L  
M  
N  
O  
P

## NORMAL OPERATING CONDITION

### Description

INFOID:000000007730105

#### FUEL CUT CONTROL (AT NO LOAD AND HIGH ENGINE SPEED)

If the engine speed is above 2,400 rpm under no load (for example, the selector lever position is neutral and engine speed is over 2,400 rpm) fuel will be cut off after some time. The exact time when the fuel is cut off varies based on engine speed. However, if the engine speed is above 4,500 rpm, fuel will be cut off in a few seconds. Fuel cut will be operated until the engine speed reaches 1,500 rpm, then fuel cut will be cancelled.

**NOTE:**

This function is different from deceleration control listed under Multiport Fuel Injection (MFI) System, [EC-573](#). "[MULTIPOINT FUEL INJECTION SYSTEM : System Description](#)".

#### TORQUE CUT CONTROL (AT HIGH ENGINE OIL TEMPERATURE)

ECM receives engine oil temperature signal from engine oil temperature sensor.

To avoid VVEL performance, ECM performs the engine torque cut control at high engine oil temperature.

If engine oil temperature is too high, engine oil viscosity will change. As a result, engine oil pressure is decreased. This control is to control the VVEL operating angle by operating the VVEL actuator sub assembly.

If this control is operated, engine performance will decrease, then maximum engine speed is reduced a little, for example.

# PERIODIC MAINTENANCE

## IDLE SPEED

### Inspection

INFOID:000000007730106

A

EC

### CHECK IDLE SPEED

 **With CONSULT**

Check idle speed in "DATA MONITOR" mode of "ENGINE" using CONSULT.

C

 **With GST**

Check idle speed with Service \$01 of GST.

D

E

F

G

H

I

J

K

L

M

N

O

P

# IGNITION TIMING

< PERIODIC MAINTENANCE >

[VQ37VHR FOR MEXICO]

## IGNITION TIMING

### Inspection

INFOID:000000007730107

### CHECK IGNITION TIMING

1. Attach timing light to loop wire as shown.

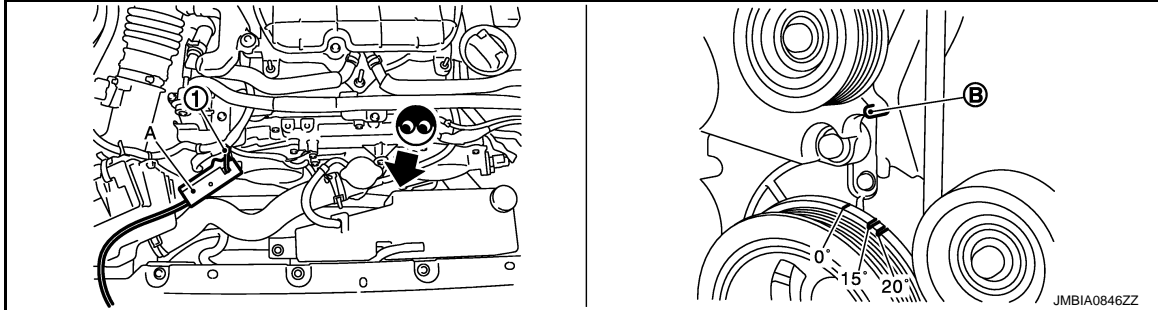

1. Loop wire
- A. Timing light
- B. Timing indicator

2. Check ignition timing.



# EVAP LEAK CHECK

< PERIODIC MAINTENANCE >

[VQ37VHR FOR MEXICO]

## EVAP LEAK CHECK

### Inspection

INFOID:000000007730108

#### CAUTION:

- Do not use compressed air or a high pressure pump.
- Do not exceed 4.12 kPa (0.042 kg/cm<sup>2</sup>, 0.6 psi) of pressure in EVAP system.

#### NOTE:

- Do not start engine.
- Improper installation of EVAP service port adapter to the EVAP service port may cause a leak.

#### Ⓟ WITH CONSULT

1. To locate the EVAP leak, install EVAP service port adapter and pressure pump to EVAP service port.
2. Turn ignition switch ON.
3. Select the "EVAP SYSTEM CLOSE" of "WORK SUPPORT" mode with CONSULT.
4. Touch "START". A bar graph (Pressure indicating display) will appear on the screen.
5. Apply positive pressure to the EVAP system until the pressure indicator reaches the middle of the bar graph.
6. Remove EVAP service port adapter and hose with pressure pump.
7. Locate the leak using a leak detector. Refer to [EC-580, "EVAP-ORATIVE EMISSION SYSTEM : System Diagram"](#).

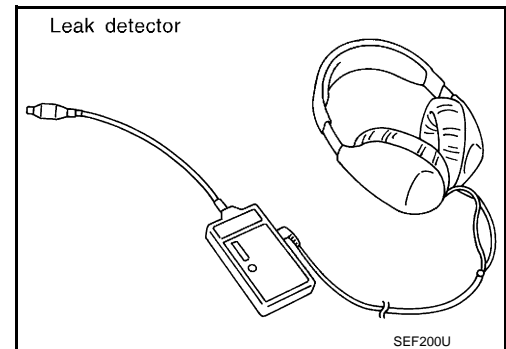
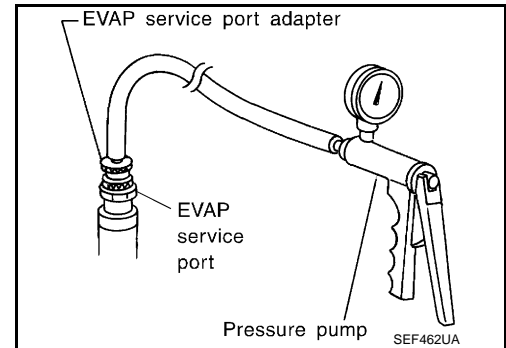

#### ⓧ WITHOUT CONSULT

1. To locate the EVAP leak, install EVAP service port adapter and pressure pump to EVAP service port.
2. Apply battery voltage between the terminals of EVAP canister vent control valve to make a closed EVAP system.
3. To locate the leak, deliver positive pressure to the EVAP system until pressure gauge points reach 1.38 to 2.76 kPa (0.014 to 0.028 kg/cm<sup>2</sup>, 0.2 to 0.4 psi).
4. Remove EVAP service port adapter and hose with pressure pump.

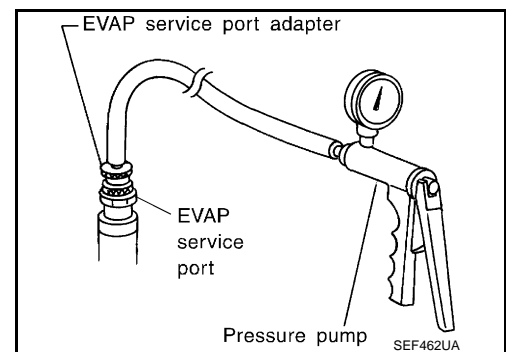

A  
EC  
C  
D  
E  
F  
G  
H  
I  
J  
K  
L  
M  
N  
O  
P

## EVAP LEAK CHECK

< PERIODIC MAINTENANCE >

[VQ37VHR FOR MEXICO]

5. Locate the leak using a leak detector. Refer to [EC-580, "EVAPORATIVE EMISSION SYSTEM : System Diagram"](#).

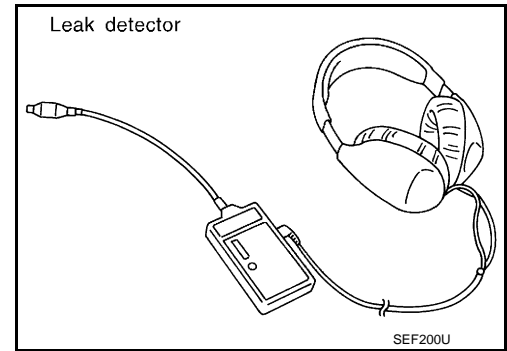

# POSITIVE CRANKCASE VENTILATION

< PERIODIC MAINTENANCE >

[VQ37VHR FOR MEXICO]

## POSITIVE CRANKCASE VENTILATION

### Inspection

INFOID:000000007730109

#### 1. CHECK PCV VALVE

With engine running at idle, remove PCV valve from rocker cover. A properly working valve makes a hissing noise as air passes through it. A strong vacuum should be felt immediately when a finger is placed over valve inlet.

Is the inspection result normal?

- YES >> INSPECTION END
- NO >> Replace PCV valve.

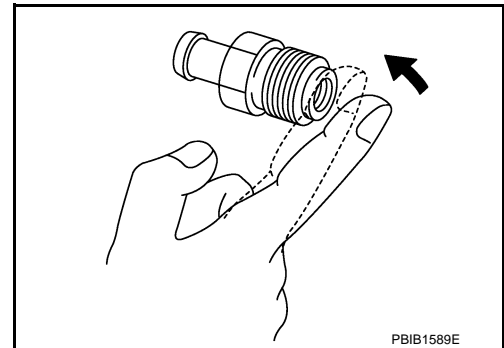

A

EC

C

D

E

F

G

H

I

J

K

L

M

N

O

P

&lt; REMOVAL AND INSTALLATION &gt;

# REMOVAL AND INSTALLATION

## ECM

### Removal and Installation

INFOID:000000007730110

#### REMOVAL

1. Remove the instrument lower cover. Refer to [IP-12, "Exploded View"](#).
2. Remove the dash side finisher (LH). Refer to [INT-34, "DASH SIDE FINISHER : Removal and Installation"](#).
3. Remove the ECM cover bolts (A) and remove ECM cover (1).

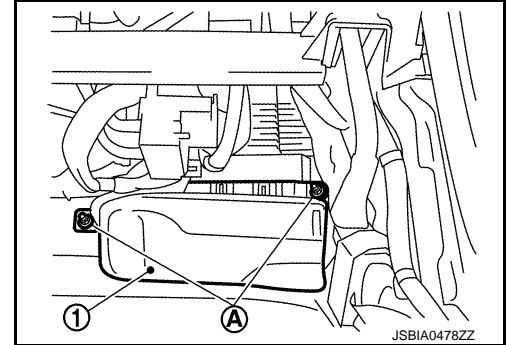

4. Disconnect ECM harness connectors.
5. Remove ECM bracket bolt (A)
6. Slide the ECM bracket (1) upward and then remove ECM bracket with ECM.
7. Remove ECM bracket bolts (B) and separate ECM (2) and ECM bracket.

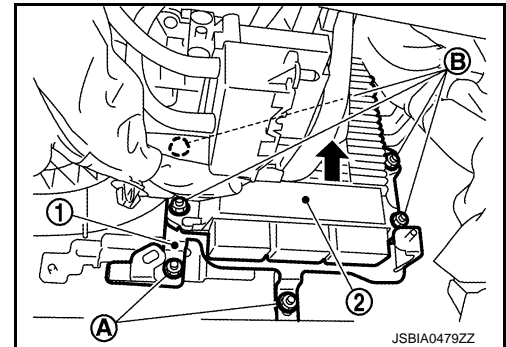

#### INSTALLATION

Install in the reverse order of removal.

**CAUTION:**

**Must be perform additional service when replacing ECM. Refer to [EC-653, "Work Procedure"](#).**

# VVEL CONTROL MODULE

< REMOVAL AND INSTALLATION >

[VQ37VHR FOR MEXICO]

## VVEL CONTROL MODULE

### Removal and Installation

INFOID:000000007730111

#### REMOVAL

1. Remove hoodledge cover (RH) and cowl top cover (RH). Refer to [EXT-21, "Exploded View"](#).
2. Remove the battery and battery tray. Refer to [PG-142, "Exploded View"](#).
3. Remove VVEL control module bracket bolts (A).
4. Remove the ground harness fix bolt (B).
5. Remove VVEL control module bracket (1).

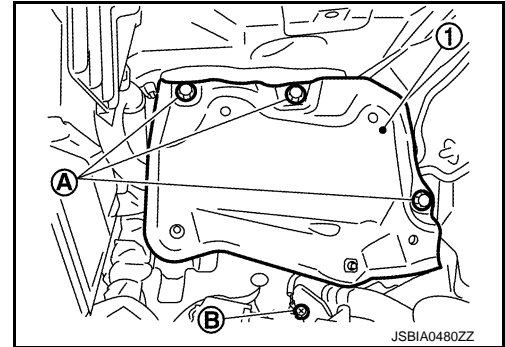

6. Disconnect VVEL control module harness connector.
7. Remove the fix bolts (A). And then separate VVEL control module (1), ground harness (2) and VVEL control module bracket (3).

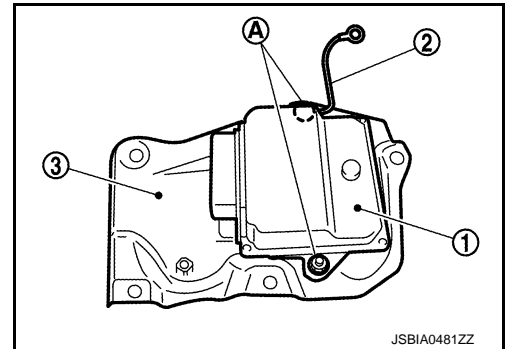

#### INSTALLATION

Install in the reverse order of removal.

#### **CAUTION:**

**Must be perform additional service when replacing VVEL control module. Refer to [EC-654, "Work Procedure"](#).**

# SERVICE DATA AND SPECIFICATIONS (SDS)

< SERVICE DATA AND SPECIFICATIONS (SDS)

[VQ37VHR FOR MEXICO]

## SERVICE DATA AND SPECIFICATIONS (SDS)

### SERVICE DATA AND SPECIFICATIONS (SDS)

#### Idle Speed

INFOID:000000007730117

| Condition                     | Specification |
|-------------------------------|---------------|
| No load* (in P or N position) | 650 ± 50 rpm  |

\*: Under the following conditions

- A/C switch: OFF
- Electric load: OFF (Lights, heater fan & rear window defogger)
- Steering wheel: Kept in straight-ahead position

#### Ignition Timing

INFOID:000000007730118

| Condition                     | Specification |
|-------------------------------|---------------|
| No load* (in P or N position) | 10 ± 2° BTDC  |

\*: Under the following conditions

- A/C switch: OFF
- Electric load: OFF (Lights, heater fan & rear window defogger)
- Steering wheel: Kept in straight-ahead position

#### Calculated Load Value

INFOID:000000007730119

| Condition    | Specification (Using CONSULT or GST) |
|--------------|--------------------------------------|
| At idle      | 5 – 35 %                             |
| At 2,500 rpm | 5 – 35 %                             |

#### Mass Air Flow Sensor

INFOID:000000007730120

|                                      |  |
|--------------------------------------|--|
| Supply voltage                       | Battery voltage (11 – 14 V)                            |
| Output voltage at idle               | 0.7 – 1.2 V*   |
| Mass air flow (Using CONSULT or GST) | 2.0 – 6.0 g/s at idle*<br>7.0 – 20.0 g/s at 2,500 rpm* |

\*: Engine is warmed up to normal operating temperature and running under no load.

PRECAUTION

PRECAUTIONS

Precaution for Supplemental Restraint System (SRS) "AIR BAG" and "SEAT BELT PRE-TENSIONER"

INFOID:000000007188839

The Supplemental Restraint System such as "AIR BAG" and "SEAT BELT PRE-TENSIONER", used along with a front seat belt, helps to reduce the risk or severity of injury to the driver and front passenger for certain types of collision. This system includes seat belt switch inputs and dual stage front air bag modules. The SRS system uses the seat belt switches to determine the front air bag deployment, and may only deploy one front air bag, depending on the severity of a collision and whether the front occupants are belted or unbelted. Information necessary to service the system safely is included in the "SRS AIR BAG" and "SEAT BELT" of this Service Manual.

**WARNING:**

Always observe the following items for preventing accidental activation.

- To avoid rendering the SRS inoperative, which could increase the risk of personal injury or death in the event of a collision that would result in air bag inflation, all maintenance must be performed by an authorized NISSAN/INFINITI dealer.
- Improper maintenance, including incorrect removal and installation of the SRS, can lead to personal injury caused by unintentional activation of the system. For removal of Spiral Cable and Air Bag Module, see "SRS AIR BAG".
- Never use electrical test equipment on any circuit related to the SRS unless instructed to in this Service Manual. SRS wiring harnesses can be identified by yellow and/or orange harnesses or harness connectors.

PRECAUTIONS WHEN USING POWER TOOLS (AIR OR ELECTRIC) AND HAMMERS

**WARNING:**

Always observe the following items for preventing accidental activation.

- When working near the Air Bag Diagnosis Sensor Unit or other Air Bag System sensors with the ignition ON or engine running, never use air or electric power tools or strike near the sensor(s) with a hammer. Heavy vibration could activate the sensor(s) and deploy the air bag(s), possibly causing serious injury.
- When using air or electric power tools or hammers, always switch the ignition OFF, disconnect the battery, and wait at least 3 minutes before performing any service.

Precaution for Procedure without Cowl Top Cover

INFOID:000000007188840

When performing the procedure after removing cowl top cover, cover the lower end of windshield with urethane, etc.

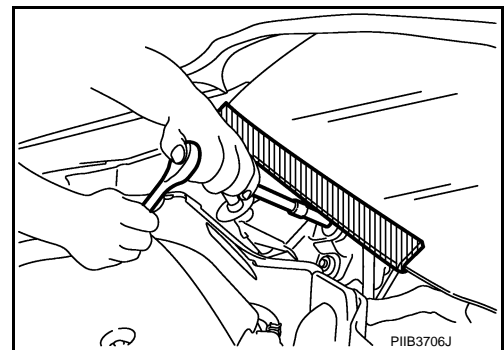

Precautions For Xenon Headlamp Service

INFOID:000000007188841

**WARNING:**

Comply with the following warnings to prevent any serious accident.

- Disconnect the battery cable (negative terminal) or the power supply fuse before installing, removing, or touching the xenon headlamp (bulb included). The xenon headlamp contains high-voltage generated parts.
- Never work with wet hands.
- Check the xenon headlamp ON-OFF status after assembling it to the vehicle. Never turn the xenon headlamp ON in other conditions. Connect the power supply to the vehicle-side connector.

A  
EC  
C  
D  
E  
F  
G  
H  
I  
J  
K  
L  
M  
N  
O  
P

# PRECAUTIONS

< PRECAUTION >

[VK56VD FOR USA AND CANADA]

(Turning it ON outside the lamp case may cause fire or visual impairments.)

- Never touch the bulb glass immediately after turning it OFF. It is extremely hot.

## CAUTION:

Comply with the following cautions to prevent any error and malfunction.

- Install the xenon bulb securely. (Insufficient bulb socket installation may melt the bulb, the connector, the housing, etc. by high-voltage leakage or corona discharge.)
- Never perform HID circuit inspection with a tester.
- Never touch the xenon bulb glass with hands. Never put oil and grease on it.
- Dispose of the used xenon bulb after packing it in thick vinyl without breaking it.
- Never wipe out dirt and contamination with organic solvent (thinner, gasoline, etc.).

## On Board Diagnostic (OBD) System of Engine and A/T

INFOID:000000007188842

The ECM has an on board diagnostic system. It will illuminate the malfunction indicator lamp (MIL) to warn the driver of a malfunction causing emission deterioration.

## CAUTION:

- Always turn the ignition switch OFF and disconnect the negative battery cable before any repair or inspection work. The open/short circuit of related switches, sensors, solenoid valves, etc. will cause the MIL to illuminate.
- Always connect and lock the connectors securely after work. A loose (unlocked) connector will cause the MIL to illuminate due to the open circuit. (Be sure the connector is free from water, grease, dirt, bent terminals, etc.)
- Certain systems and components, especially those related to OBD, may use a new style slide-locking type harness connector. For description and how to disconnect, refer to [EC-1033, "Diagnosis Description"](#).
- Always route and secure the harnesses properly after work. The interference of the harness with a bracket, etc. may cause the MIL to illuminate due to the short circuit.
- Always connect rubber tubes properly after work. A misconnected or disconnected rubber tube may cause the MIL to illuminate due to the malfunction of the EVAP system or fuel injection system, etc.
- Always erase the unnecessary malfunction information (repairs completed) from the ECM and TCM (Transmission control module) before returning the vehicle to the customer.

## General Precautions

INFOID:000000007188843

- Always use a 12 volt battery as power source.
- Never attempt to disconnect battery cables while engine is running.
- Before connecting or disconnecting the ECM harness connector, turn ignition switch OFF and disconnect negative battery cable. Failure to do so may damage the ECM because battery voltage is applied to ECM even if ignition switch is turned OFF.
- Before removing parts, turn ignition switch OFF and then disconnect battery ground cable.

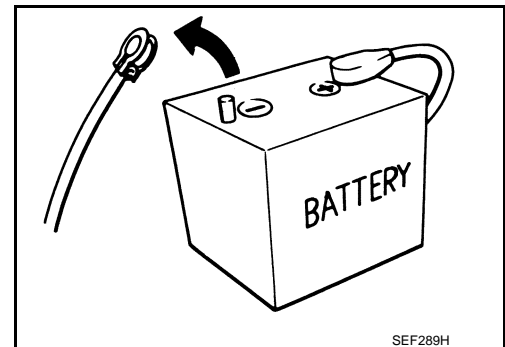

- Never disassemble ECM.
- If a battery cable is disconnected, the memory will return to the ECM value.  
The ECM will now start to self-control at its initial value. Thus, engine operation can vary slightly in this case. However, this is not an indication of a malfunction. Never replace parts because of a slight variation.
- If the battery is disconnected, the following emission-related diagnostic information will be lost within 24 hours.

- Diagnostic trouble codes
- 1st trip diagnostic trouble codes
- Freeze frame data
- 1st trip freeze frame data
- System readiness test (SRT) codes
- Test values

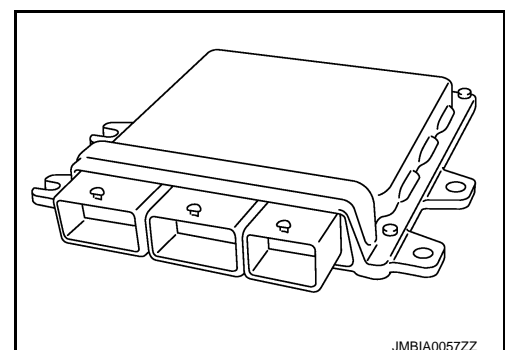



# PRECAUTIONS

[VK56VD FOR USA AND CANADA]

## < PRECAUTION >

- When connecting ECM harness connector (A), fasten (B) it securely with a lever as far as it will go as shown in the figure.
  - ECM (1)
  - Loosen (C)

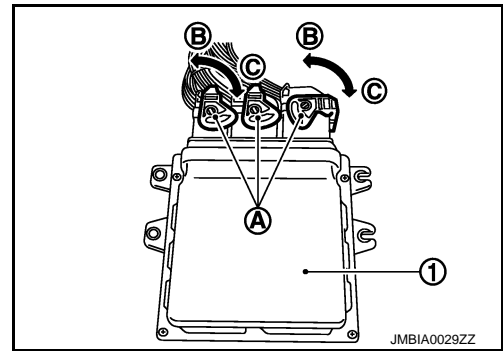

- When connecting or disconnecting pin connectors into or from ECM, never damage pin terminals (bends or break). Check that there are not any bends or breaks on ECM pin terminal, when connecting pin connectors.
- Securely connect ECM harness connectors. A poor connection can cause an extremely high (surge) voltage to develop in coil and condenser, thus resulting in damage to ICs.
- Keep engine control system harness at least 10 cm (4 in) away from adjacent harness, to prevent engine control system malfunctions due to receiving external noise, degraded operation of ICs, etc.
- Keep engine control system parts and harness dry.
- Before replacing ECM, perform ECM Terminals and Reference Value inspection and check that ECM functions properly. Refer to [EC-1055, "Reference Value"](#).
- Handle mass air flow sensor carefully to avoid damage.
- Never clean mass air flow sensor with any type of detergent.
- Never disassemble electric throttle control actuator.
- Even a slight leakage in the air intake system can cause serious incidents.
- Never shock or jar the camshaft position sensor, crankshaft position sensor.

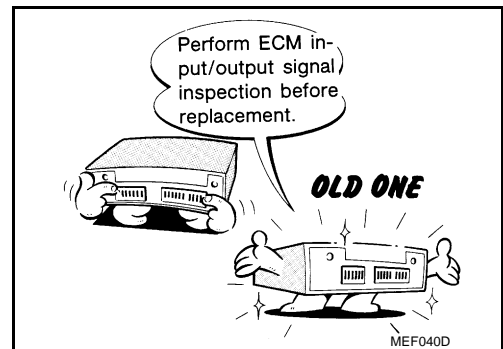
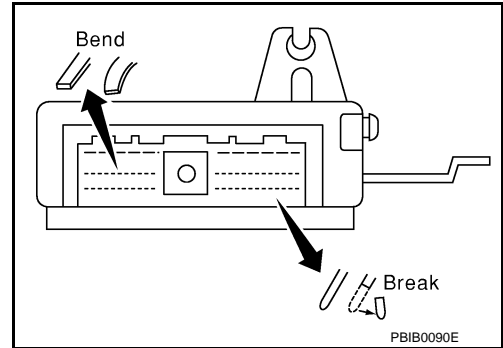

- After performing each TROUBLE DIAGNOSIS, perform DTC Confirmation Procedure or Component Function Check. The DTC should not be displayed in the DTC Confirmation Procedure if the repair is completed. The Component Function Check should be a good result if the repair is completed.

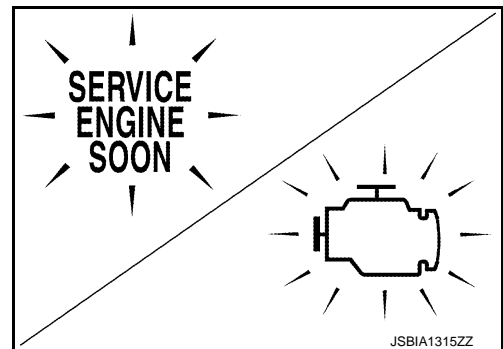

A  
EC  
C  
D  
E  
F  
G  
H  
I  
J  
K  
L  
M  
N  
O  
P

# PRECAUTIONS

[VK56VD FOR USA AND CANADA]

## < PRECAUTION >

- When measuring ECM signals with a circuit tester, never allow the two tester probes to contact. Accidental contact of probes will cause a short circuit and damage the ECM power transistor.

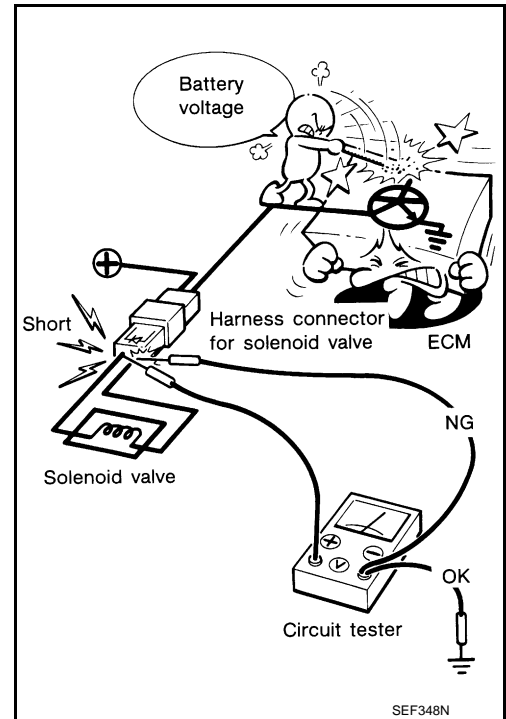

- B1 indicates bank 1, B2 indicates bank 2 as shown in the figure.
- Never operate fuel pump when there is no fuel in lines.
- Tighten fuel hose clamps to the specified torque.

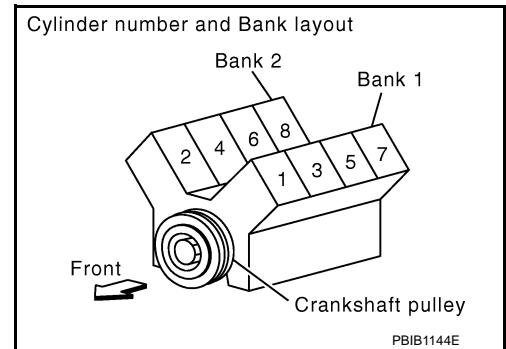

- Never depress accelerator pedal when starting.
- Immediately after starting, never rev up engine unnecessarily.
- Never rev up engine just prior to shutdown.

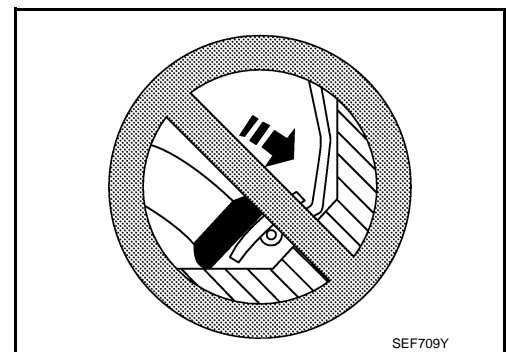

## PRECAUTIONS

[VK56VD FOR USA AND CANADA]

< PRECAUTION >

- When installing C.B. ham radio or a mobile phone, be sure to observe the following as it may adversely affect electronic control systems depending on installation location.
- Keep the antenna as far as possible from the electronic control units.
- Keep the antenna feeder line more than 20 cm (8 in) away from the harness of electronic controls. Never let them run parallel for a long distance.
- Adjust the antenna and feeder line so that the standing-wave ratio can be kept smaller.
- Be sure to ground the radio to vehicle body.

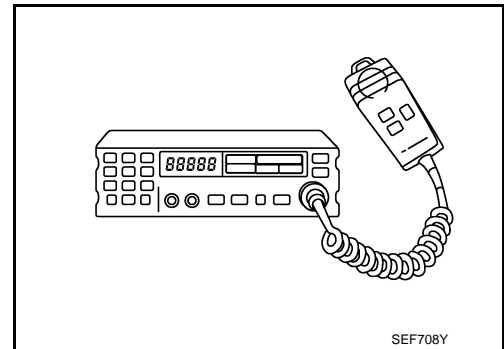

A

EC

C

D

E

F

G

H

I

J

K

L

M

N

O

P

# PREPARATION

< PREPARATION >

[VK56VD FOR USA AND CANADA]

## PREPARATION

### PREPARATION

#### Special Service Tools

INFOID:000000007188844

| Tool number<br>(Kent-Moore No.)<br>Tool name | Description             |
|--|-------------------------|
| KV10120000<br>(—)<br>Fuel tube adapter       | Measuring fuel pressure |

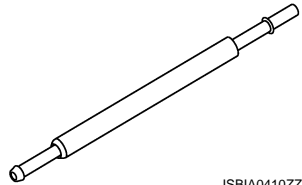

#### Commercial Service Tools

INFOID:000000007188845

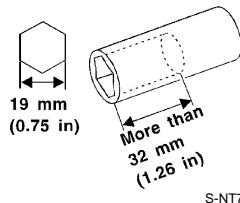
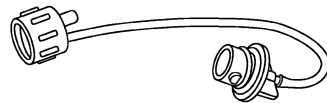
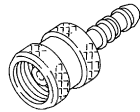
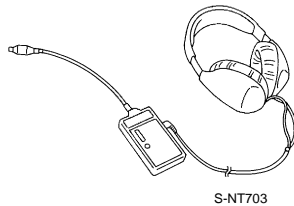

| Tool name<br>(Kent-Moore No.)                      | Description  |
|--|--|
| Leak detector<br>i.e.: (J-41416)                   | Locates the EVAP leak                                  |
| EVAP service port<br>adapter<br>i.e.: (J-41413-OB) | Applies positive pressure through EVAP service port    |
| Fuel filler cap adapter<br>i.e.: (MLR-8382)        | Checks fuel tank vacuum relief valve opening pressure  |
| Socket wrench                                      | Removes and installs engine coolant temperature sensor |



# PREPARATION

< PREPARATION >

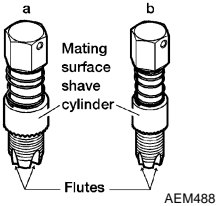
[VK56VD FOR USA AND CANADA]

| Tool name<br>(Kent-Moore No.)   | Description  | A                          |
|---|--|----------------------------|
| <p>Oxygen sensor thread cleaner<br/>i.e.: (J-43897-18)<br/>(J-43897-12)</p>                                | <p>Reconditions the exhaust system threads before installing a new oxygen sensor. Use with anti-seize lubricant shown below.<br/><b>a: 18 mm diameter with pitch 1.5 mm for Zirconia Oxygen Sensor</b><br/><b>b: 12 mm diameter with pitch 1.25 mm for Titania Oxygen Sensor</b></p> | <p>EC</p> <p>C</p>         |
| <p>Anti-seize lubricant<br/>i.e.: (Permatex™ 133AR or equivalent meeting MIL specification MIL-A-907)</p>  | <p>Lubricates oxygen sensor thread cleaning tool when reconditioning exhaust system threads.</p>   | <p>D</p> <p>E</p> <p>F</p> |

G

H

I

J

K

L

M

N

O

P

# COMPONENT PARTS

< SYSTEM DESCRIPTION >

[VK56VD FOR USA AND CANADA]

## SYSTEM DESCRIPTION

### COMPONENT PARTS

#### ENGINE CONTROL SYSTEM

#### ENGINE CONTROL SYSTEM : Component Parts Location

INFOID:000000007187142

#### ENGINE ROOM COMPARTMENT

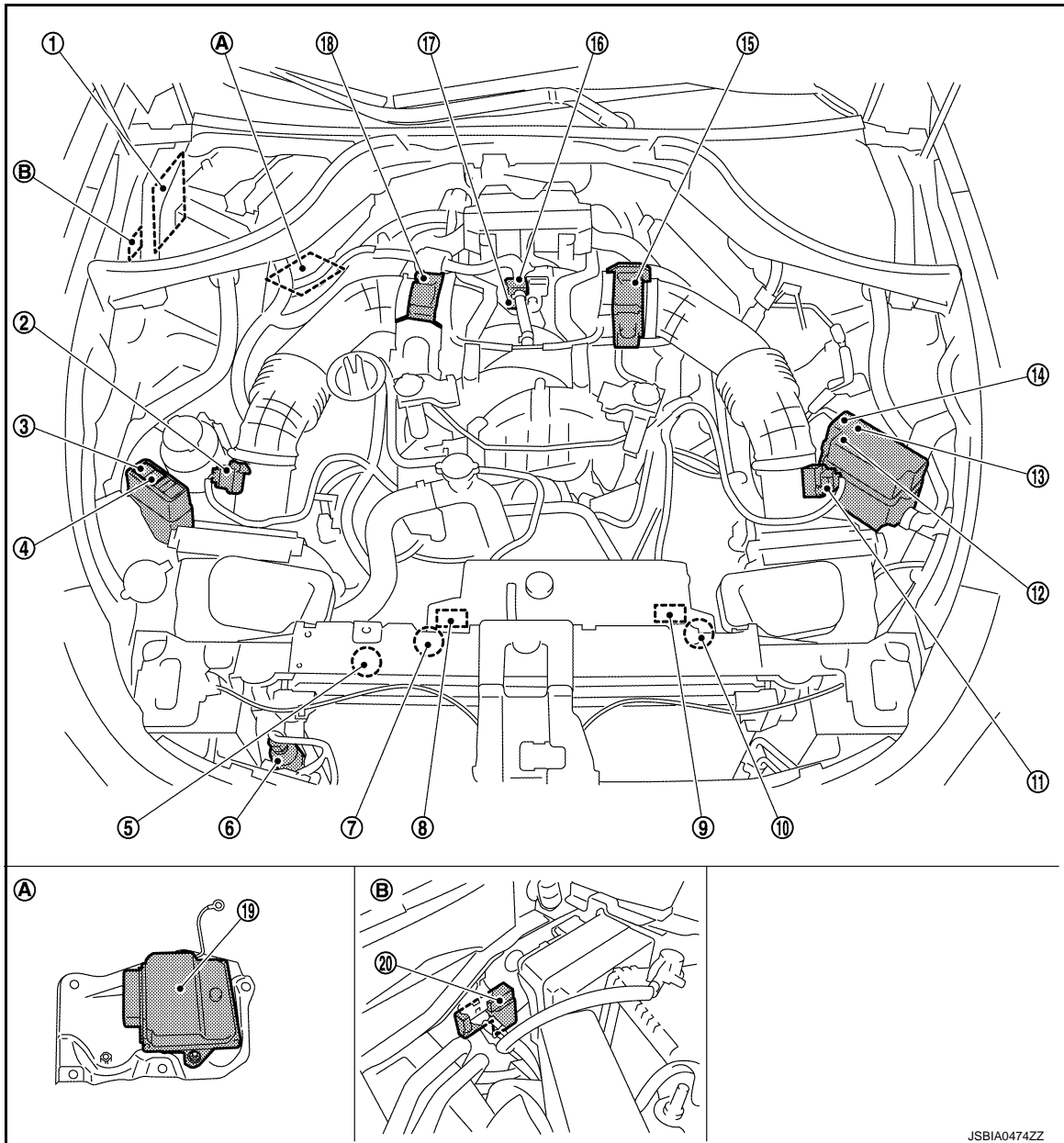

- |   |   |                                 |
|---|---|---------------------------------|
| 1. IPDM E/R<br><a href="#">PCS-5. "IPDM E/R : Component Parts Location"</a> | 2. Mass air flow sensor   | 3. Cooling fan relay 2          |
| 4. Injector relay 2   | 5. Power steering pressure sensor<br><a href="#">ST-76. "2WD : Exploded View"</a> (2WD models)<br><a href="#">ST-78. "AWD : Exploded View"</a> (AWD models) | 6. Refrigerant pressure sensor  |
| 7. Cooling fan motor 2  | 8. Cooling fan control module 2   | 9. Cooling fan control module 1 |

# COMPONENT PARTS

< SYSTEM DESCRIPTION >

[VK56VD FOR USA AND CANADA]

- |  |  |  |
|--|--|--|
| 10. Cooling fan motor 1                                  | 11. Mass air flow sensor<br>(with intake air temperature sensor)<br>(bank 1) | 12. Injector relay 1                               |
| 13. VVEL actuator motor relay                            | 14. Cooling fan relay 1  | 15. Electric throttle control actuator<br>(bank 1) |
| 16. EVAP canister purge volume control<br>solenoid valve | 17. Manifold absolute pressure (MAP)<br>sensor                               | 18. Electric throttle control actuator<br>(bank 2) |
| 19. VVEL control module                                  | 20. Battery current sensor<br>(with battery temperature sensor)              |  |
| A. Under the battery tray<br>(View with upside-down)     | B. Body side in battery case   |  |

## ENGINE COMPARTMENT

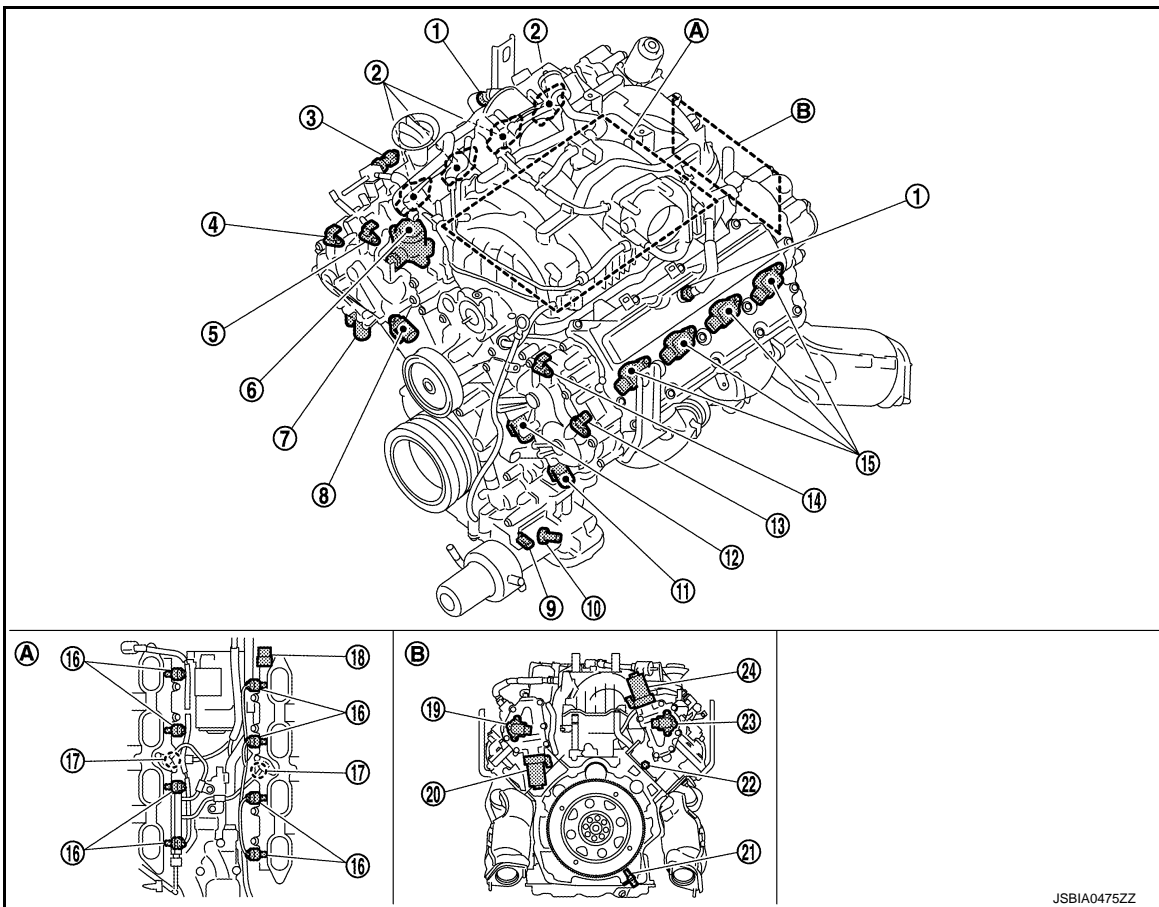

- |   |  |   |
|---|--|---|
| 1. Positive crankcase ventilation (PCV) valve             | 2. Ignition coil (with power transistor) and spark plug (bank 2) | 3. Low fuel pressure sensor                                       |
| 4. Exhaust valve timing control position sensor (bank 2)  | 5. Camshaft position sensor (bank 2)                             | 6. High pressure fuel pump  |
| 7. Exhaust valve timing control solenoid valve (bank 2)   | 8. Intake valve timing control solenoid valve (bank 2)           | 9. Engine oil temperature sensor                                  |
| 10. Engine oil pressure sensor                            | 11. Exhaust valve timing control solenoid valve (bank 1)         | 12. Intake valve timing control solenoid valve (bank 1)           |
| 13. Exhaust valve timing control position sensor (bank 1) | 14. Camshaft position sensor (bank 1)                            | 15. Ignition coil (with power transistor) and spark plug (bank 1) |
| 16. Fuel injector   | 17. Knock sensor   | 18. Fuel rail pressure sensor                                     |
| 19. VVEL control shaft position sensor (bank 1)           | 20. VVEL actuator motor (bank 1)                                 | 21. Crankshaft position sensor                                    |

# COMPONENT PARTS

[VK56VD FOR USA AND CANADA]

## < SYSTEM DESCRIPTION >

- |   |   |                                  |
|---|---|----------------------------------|
| 22. Engine coolant temperature sensor                               | 23. VVEL control shaft position sensor (bank 2) | 24. VVEL actuator motor (bank 2) |
| A. Top view of the engine<br>(View with intake manifold is removed) | B. Rear view of the engine                      |                                  |

## EXHAUST COMPARTMENT

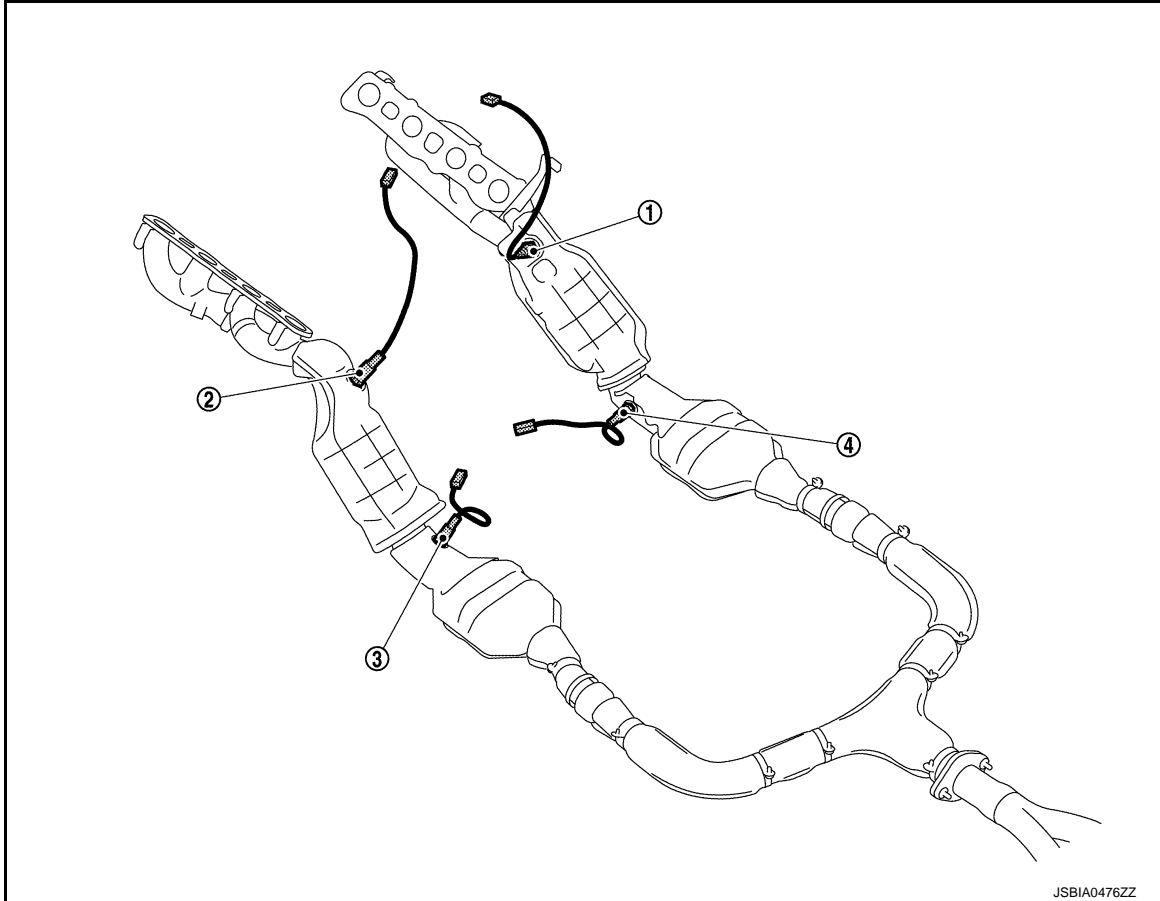

- |                                    |                          |                                    |
|------------------------------------|--------------------------|------------------------------------|
| 1. A/F sensor 1 (bank 2)           | 2. A/F sensor 1 (bank 1) | 3. Heated oxygen sensor 2 (bank 1) |
| 4. Heated oxygen sensor 2 (bank 2) |                          |                                    |

## BODY COMPARTMENT



# COMPONENT PARTS

< SYSTEM DESCRIPTION >

[VK56VD FOR USA AND CANADA]

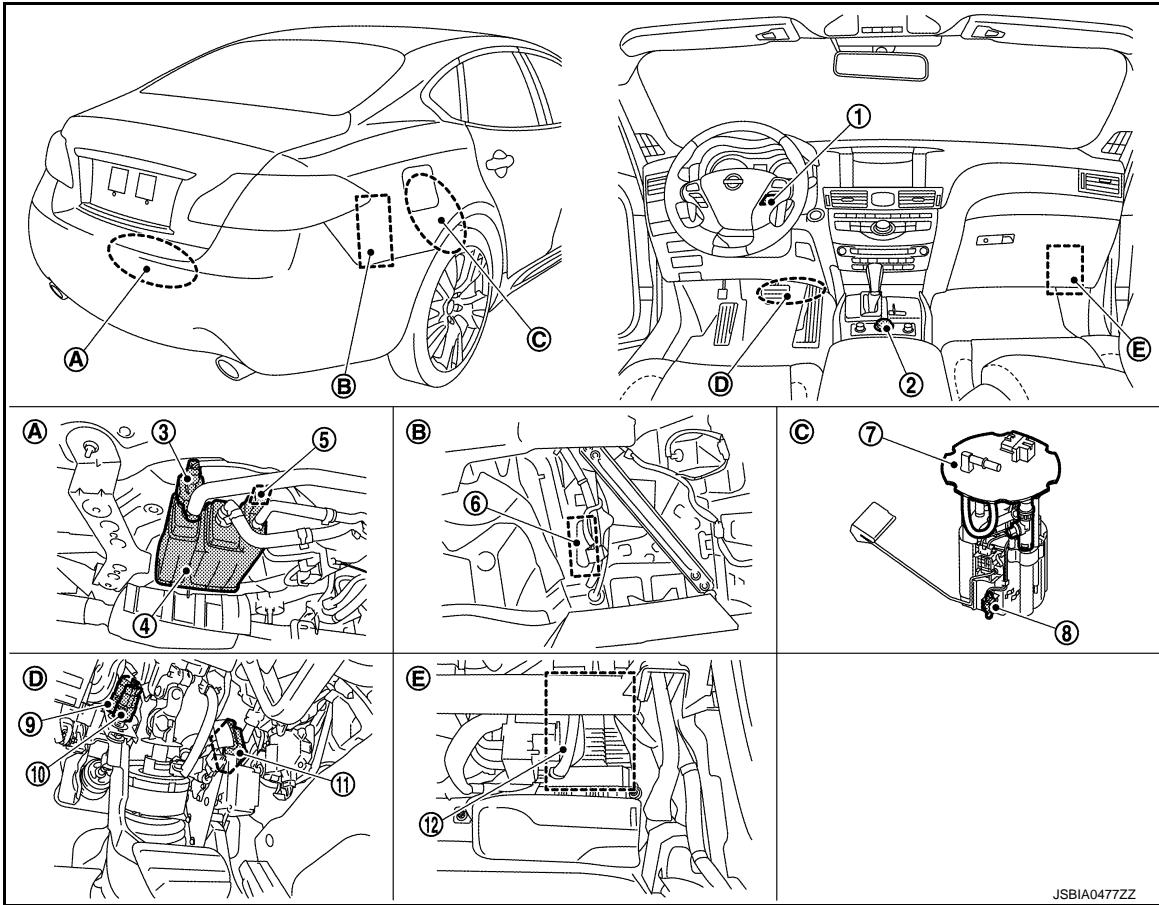

- |   |  |                                     |
|---|--|-------------------------------------|
| 1. ASCD steering switch<br>ICC steering switch                | 2. Drive mode select switch            | 3. EVAP canister vent control valve |
| 4. EVAP canister  | 5. EVAP control system pressure sensor | 6. Fuel pump control module (FPCM)  |
| 7. Fuel level sensor unit, fuel filter and fuel pump assembly | 8. Fuel tank temperature sensor        | 9. Stop lamp switch                 |
| 10. ASCD brake switch<br>ICC brake switch                     | 11. Accelerator pedal position sensor  | 12. ECM                             |

## ENGINE CONTROL SYSTEM : Component Description

INFOID:000000007187143

| Component                           | Reference  |
|-------------------------------------|--|
| ECM                                 | <a href="#">EC-999. "ECM"</a>  |
| Malfunction indicator lamp          | <a href="#">EC-1006. "Malfunction Indicator Lamp (MIL)"</a>                          |
| Ignition coil with power transistor | <a href="#">EC-1005. "Ignition Coil With Power Transistor"</a>                       |
| Accelerator pedal position sensor   | <a href="#">EC-996. "Accelerator Pedal Position Sensor"</a>                          |
| Mass air flow sensor                | <a href="#">EC-1006. "Mass Air Flow Sensor (With Intake Air Temperature Sensor)"</a> |
| Intake air temperature sensor       |  |
| Electric throttle control actuator  | <a href="#">EC-999. "Electric Throttle Control Actuator"</a>                         |
| Throttle control motor              |  |
| Throttle position sensor            |  |
| Crankshaft position sensor          | <a href="#">EC-998. "Crankshaft Position Sensor"</a>                                 |
| Camshaft position sensor            | <a href="#">EC-997. "Camshaft Position Sensor"</a>                                   |
| Engine coolant temperature sensor   | <a href="#">EC-1000. "Engine Coolant Temperature Sensor"</a>                         |

# COMPONENT PARTS

< SYSTEM DESCRIPTION >

[VK56VD FOR USA AND CANADA]

| Component  | Reference  |
|--|--|
| Engine oil pressure sensor                               | <a href="#">EC-1000, "Engine Oil Pressure Sensor"</a>                              |
| Engine oil temperature sensor                            | <a href="#">EC-1000, "Engine Oil Temperature Sensor"</a>                           |
| Fuel injector  | <a href="#">EC-1002, "Fuel Injector"</a>   |
| Low pressure fuel pump                                   | <a href="#">EC-1006, "Low Pressure Fuel Pump"</a>                                  |
| Low fuel pressure sensor                                 | <a href="#">EC-1006, "Low Fuel Pressure Sensor"</a>                                |
| Fuel pump control module (FPCM)                          | <a href="#">EC-1004, "Fuel Pump Control Module"</a>                                |
| High pressure fuel pump                                  | <a href="#">EC-1003, "High Pressure Fuel Pump"</a>                                 |
| Fuel tank temperature sensor                             | <a href="#">EC-1002, "Fuel Tank Temperature Sensor"</a>                            |
| Fuel rail pressure sensor                                | <a href="#">EC-1004, "Fuel Rail Pressure Sensor"</a>                               |
| A/F sensor 1   | <a href="#">EC-996, "Air Fuel Ratio (A/F) Sensor 1"</a>                            |
| A/F sensor 1 heater                                      |  |
| Heated oxygen sensor 2                                   | <a href="#">EC-1003, "Heated Oxygen Sensor 2"</a>                                  |
| Heated oxygen sensor 2 heater                            |  |
| Manifold absolute pressure sensor                        | <a href="#">EC-1006, "Manifold Absolute Pressure Sensor"</a>                       |
| Knock sensor   | <a href="#">EC-1005, "Knock Sensor"</a>  |
| Power steering pressure sensor                           | <a href="#">EC-1007, "Power Steering Pressure (PSP) Sensor"</a>                    |
| Cooling fan control module                               | <a href="#">EC-998, "Cooling Fan"</a>  |
| Cooling fan motor  |  |
| Intake valve timing control solenoid valve               | <a href="#">EC-1005, "Intake Valve Timing Control Solenoid Valve"</a>              |
| Exhaust valve timing control position sensor             | <a href="#">EC-1002, "Exhaust Valve Timing Control Position Sensor"</a>            |
| Exhaust valve timing control solenoid valve              | <a href="#">EC-1002, "Exhaust Valve Timing Control Solenoid Valve"</a>             |
| VVEL control module                                      | <a href="#">EC-1008, "VVEL Control Module"</a>                                     |
| VVEL actuator motor relay                                | <a href="#">EC-1008, "VVEL Actuator Motor Relay"</a>                               |
| VVEL actuator motor                                      | <a href="#">EC-1008, "VVEL Actuator Motor"</a>                                     |
| VVEL control shaft position sensor                       | <a href="#">EC-1008, "VVEL Control Shaft Position Sensor"</a>                      |
| EVAP control system pressure sensor                      | <a href="#">EC-1001, "EVAP Control System Pressure Sensor"</a>                     |
| EVAP canister vent control valve                         | <a href="#">EC-1001, "EVAP Canister Vent Control Valve"</a>                        |
| EVAP canister purge volume control solenoid valve        | <a href="#">EC-1001, "EVAP Canister Purge Volume Control Solenoid Valve"</a>       |
| PCV valve  | <a href="#">EC-1009, "Positive Crankcase Ventilation"</a>                          |
| Brake booster pressure sensor (Vacuum sensor)            | <a href="#">BRC-12, "Vacuum Sensor"</a>  |
| Battery current sensor (with battery temperature sensor) | <a href="#">EC-997, "Battery Current Sensor (With Battery Temperature Sensor)"</a> |
| Refrigerant pressure sensor                              | <a href="#">EC-1007, "Refrigerant Pressure Sensor"</a>                             |
| Stop lamp switch   | <a href="#">EC-1007, "Stop Lamp Switch"</a>  |
| ASCD brake switch  | <a href="#">EC-996, "ASCD Brake Switch"</a>  |
| ASCD steering switch                                     | <a href="#">EC-996, "ASCD Steering Switch"</a>                                     |
| Information display                                      | <a href="#">EC-1005, "Information Display"</a>                                     |
| ICC steering switch                                      | <a href="#">EC-1004, "ICC Steering Switch"</a>                                     |
| ICC brake switch   | <a href="#">EC-1004, "ICC Brake Switch"</a>  |

## Infiniti Drive Mode Selector

# COMPONENT PARTS

< SYSTEM DESCRIPTION >

[VK56VD FOR USA AND CANADA]

## Infiniti Drive Mode Selector : Component Parts Location

INFOID:000000007187144

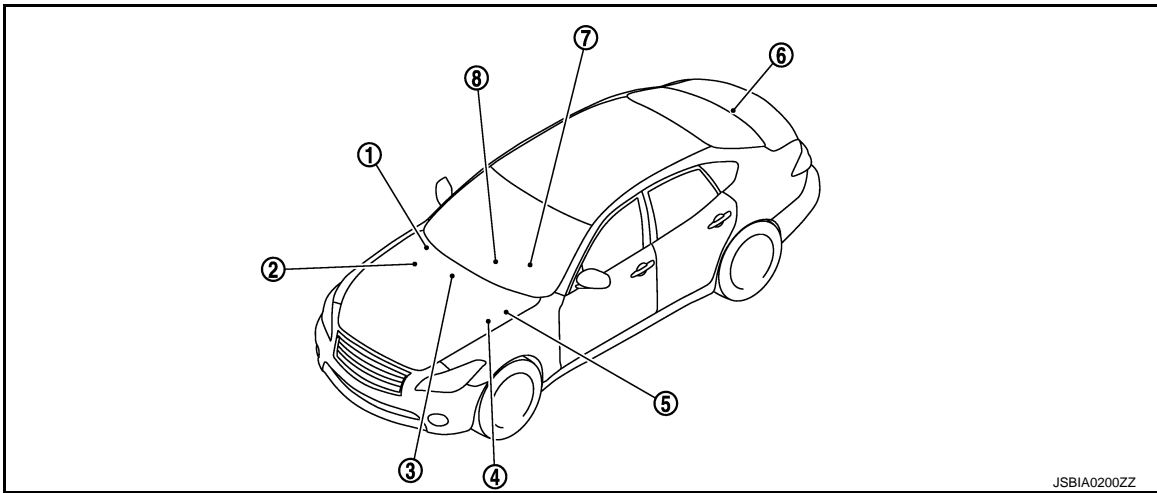

- |   |  |   |
|---|--|---|
| <p>1. A/C auto amp.<br/>Refer to <a href="#">MWI-6, "METER SYSTEM : Component Parts Location"</a> (WITH FOREST AIR).<br/>Refer to <a href="#">HAC-10, "AUTOMATIC AIR CONDITIONING SYSTEM (WITHOUT FOREST AIR) : Component Parts Location"</a> (WITHOUT FOREST AIR).</p> | <p>2. ECM<br/>Refer to <a href="#">EC-990, "ENGINE CONTROL SYSTEM : Component Parts Location"</a>.</p> | <p>3. AV control unit<br/>Refer to <a href="#">AV-10, "Component Parts Location"</a> (BASE AUDIO WITHOUT NAVIGATION).<br/>Refer to <a href="#">AV-127, "Component Parts Location"</a> (BOSE AUDIO WITH NAVIGATION).</p> |
| <p>4. Accelerator pedal actuator</p>  | <p>5. Combination meter<br/>(Vehicle information display, and ECO drive indicator)</p>                 | <p>6. ADAS control unit<br/><a href="#">DAS-14, "Component Parts Location"</a>.</p>   |
| <p>7. TCM<br/><a href="#">TM-10, "A/T CONTROL SYSTEM : Component Parts Location"</a>.</p>   | <p>8. Drive mode select switch</p>   |   |

## Infiniti Drive Mode Selector : Component Description

INFOID:000000007187145

| Part name                | Description   |
|--------------------------|---|
| Drive mode select switch | Transmits an ON/OFF state signal of STANDARD, SPORT, ECO, or SNOW mode to the A/C auto amp.   |
| A/C auto amp.            | Transmits an input signal (ON/OFF state of each mode) received from the drive mode select switch to the TCM, combination meter, 4WAS main control unit, and ADAS control unit via CAN communication.  |
| AV control unit          | Transmits an ECO pedal* reaction force setting signal (Standard/Soft/OFF) to ECM via CAN communication. This signal determines reaction force of the accelerator pedal.   |
| TCM                      | Transmits a state of a mode received from the A/C auto amp. to ECM.   |
| ECM                      | <ul style="list-style-type: none"> <li>Receives a ECO mode signal from TCM and controls throttle angle characteristics and torque.</li> <li>Determines reaction force in accordance with the accelerator pedal operation when in ECO mode and transmits an ECO pedal* reaction force control signal to the ADAS control unit. When receiving the ECO pedal* reaction force setting signal (Standard/Soft/OFF) from the AV control unit, ECM updates ECO pedal* reaction force. Furthermore, ECM sends back the received signal to the AV control unit for confirmation.</li> <li>Controls the ECO drive indicator when in ECO mode. The ECO drive indicator turns ON or blinks (with ECO pedal*) according to accelerator pedal operation.</li> </ul> |
| Combination meter        | <ul style="list-style-type: none"> <li>Indicates a mode state on the vehicle information display, based on a mode state signal received from the A/C auto amp.</li> <li>Turns ON or blinks (with ECO pedal*) the ECO drive indicator according to a request from ECM when in ECO mode.</li> </ul>   |

# COMPONENT PARTS

< SYSTEM DESCRIPTION >

[VK56VD FOR USA AND CANADA]

| Part name                  | Description   |
|----------------------------|---|
| ADAS control unit          | Controls accelerator pedal reaction force of the accelerator pedal actuator when in ECO mode, based on an ECO pedal* reaction force control signal received from ECM. |
| Accelerator pedal actuator | Applies reaction force to the accelerator pedal when in ECO mode, based on an accelerator pedal reaction force control signal received from the ADAS control unit.    |

\*: ECO pedal control is only for vehicles with intelligent pedal (distance control assist).

## Accelerator Pedal Position Sensor

INFOID:000000007187146

The accelerator pedal position sensor is installed on the accelerator pedal assembly. The sensor detects the accelerator position and sends a signal to the ECM.

Accelerator pedal position sensor has two sensors. These sensors are a kind of potentiometer which transform the accelerator pedal position into output voltage, and emit the voltage signals to the ECM. The ECM judges the current opening angle of the accelerator pedal from these signals and controls the throttle control motor based on these signals.

Idle position of the accelerator pedal is determined by the ECM receiving the signal from the accelerator pedal position sensor. The ECM uses this signal for engine operations such as fuel cut.

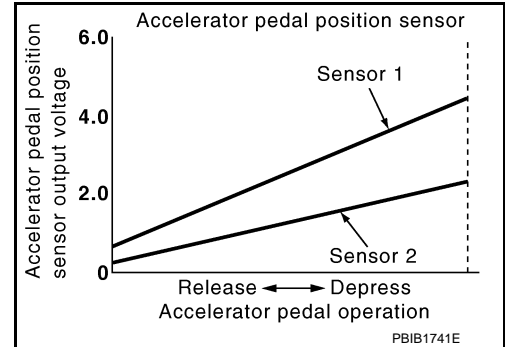

## Air Fuel Ratio (A/F) Sensor 1

INFOID:000000007187147

### DESCRIPTION

The sensor element of the A/F sensor 1 is composed an electrode layer, which transports ions. It has a heater in the element.

The sensor is capable of precise measurement  $\lambda = 1$ , but also in the lean and rich range. Together with its control electronics, the sensor outputs a clear, continuous signal throughout a wide  $\lambda$  range.

The exhaust gas components diffuse through the diffusion layer at the sensor cell. An electrode layer is applied voltage, and this current relative oxygen density in lean. Also this current relative hydrocarbon density in rich.

Therefore, the A/F sensor 1 is able to indicate air fuel ratio by this electrode layer of current. In addition, a heater is integrated in the sensor to ensure the required operating temperature of approximately 760°C (1,400°F).

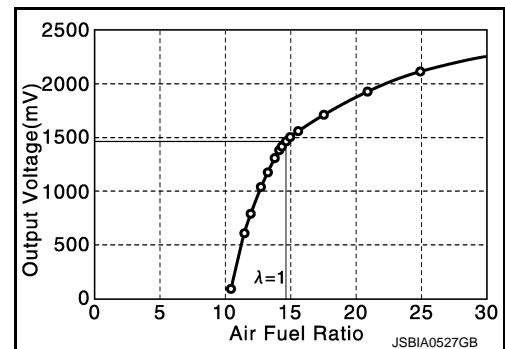

### A/F SENSOR 1 HEATER

A/F sensor 1 heater is integrated in the sensor.

The ECM performs ON/OFF duty control of the A/F sensor 1 heater corresponding to the engine operating condition to keep the temperature of A/F sensor 1 element within the specified range.

### ASCD Brake Switch

INFOID:000000007187148

When the brake pedal is depressed, ASCD brake switch is turned OFF and stop lamp switch is turned ON. ECM detects the state of the brake pedal by those two types of input (ON/OFF signal).

### ASCD Steering Switch

INFOID:000000007187149

ASCD steering switch has variant values of electrical resistance for each button. ECM reads voltage variation of switch, and determines which button is operated.

# COMPONENT PARTS

< SYSTEM DESCRIPTION >

[VK56VD FOR USA AND CANADA]

## Battery Current Sensor (With Battery Temperature Sensor)

INFOID:000000007187150

### OUTLINE

The power generation voltage variable control enables fuel consumption to be decreased by reducing the engine load which is caused by the power generation of the generator.

Based on sensor signals, ECM judges whether or not the power generation voltage variable control is performed. When performing the power generation voltage variable control, ECM calculates the target power generation voltage based on the sensor signal. And ECM sends the calculated value as the power generation command value to IPDM E/R. For the details of the power generation voltage variable control, refer to [CHG-8. "POWER GENERATION VOLTAGE VARIABLE CONTROL SYSTEM : System Description"](#).

#### CAUTION:

**Never connect the electrical component or the ground wire directly to the battery terminal. The connection causes the malfunction of the power generation voltage variable control, and then the battery discharge may occur.**

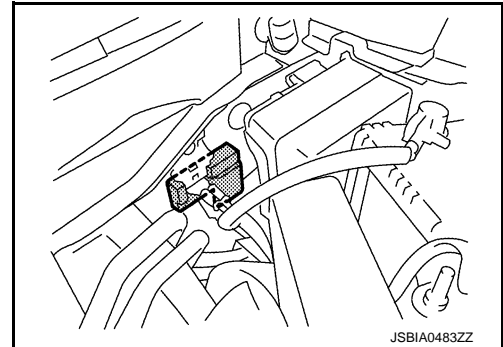

### BATTERY CURRENT SENSOR

The battery current sensor is installed to the battery negative cable. The sensor measures the charging/discharging current of the battery.

### BATTERY TEMPERATURE SENSOR

Battery temperature sensor is integrated in battery current sensor. The sensor measures temperature around the battery. The electrical resistance of the thermistor decreases as temperature increases.

#### <Reference data>

| Temperature [°C (°F)] | Voltage* (V) | Resistance (kΩ) |
|-----------------------|--------------|-----------------|
| 25 (77)               | 3.333        | 1.9 - 2.1       |
| 90 (194)              | 0.969        | 0.222 - 0.258   |

\*: These data are reference values and are measured between battery temperature sensor signal terminal and sensor ground.

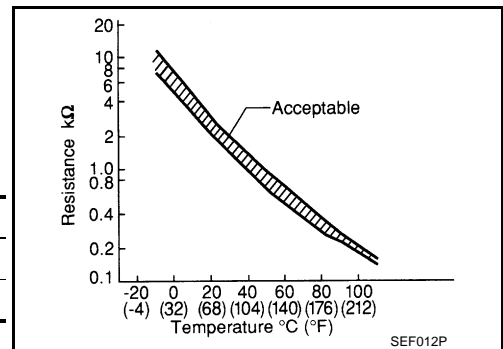

## Camshaft Position Sensor

INFOID:000000007187151

The camshaft position sensor senses the protrusion of the signal plate installed to the camshaft (INT) front end to identify a particular cylinder. The camshaft position sensor senses the piston position.

When the crankshaft position sensor system becomes inoperative, the camshaft position sensor provides various controls of engine parts instead, utilizing timing of cylinder identification signals.

The sensor consists of a permanent magnet and Hall IC.

When engine is running, the high and low parts of the teeth cause the gap with the sensor to change.

The changing gap causes the magnetic field near the sensor to change.

Due to the changing magnetic field, the voltage from the sensor changes.

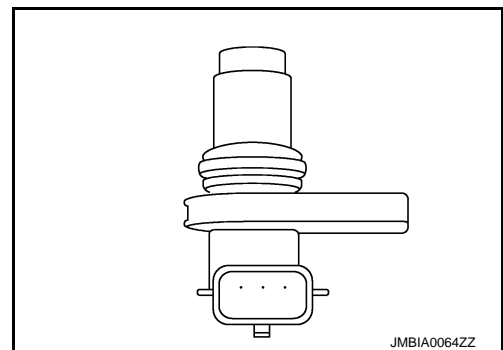

# COMPONENT PARTS

< SYSTEM DESCRIPTION >

[VK56VD FOR USA AND CANADA]

ECM receives the signals as shown in the figure.

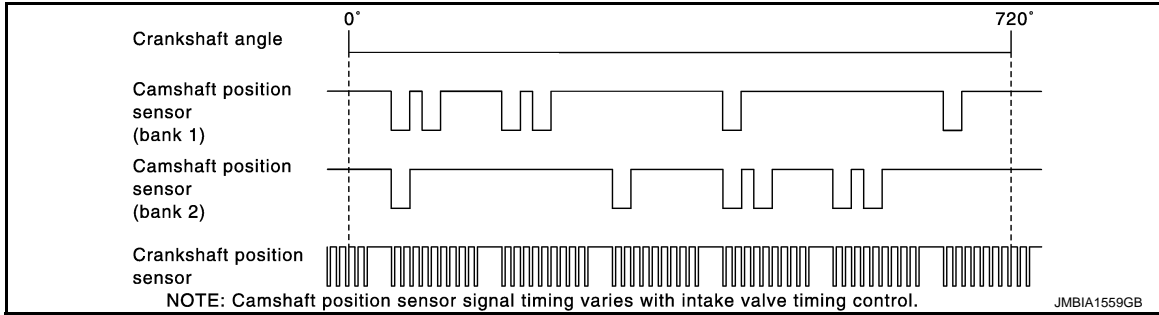

## Cooling Fan

INFOID:000000007187152

### COOLING FAN CONTROL MODULE

Cooling fan control module receives ON/OFF pulse duty signal from IPDM E/R. Corresponding to this ON/OFF pulse duty signal, cooling fan control module sends cooling fan motor operating voltage to cooling fan motor. The revolution speed of cooling fan motor is controlled by duty cycle of the voltage.

### COOLING FAN MOTOR

Cooling fan motor receives cooling fan motor operating voltage from cooling fan control module. The revolution speed of cooling fan motor is controlled by duty cycle of the voltage.

## Crankshaft Position Sensor

INFOID:000000007187153

The crankshaft position sensor is located on the cylinder block facing the gear teeth (cogs) of the signal plate. It detects the fluctuation of the engine revolution.

The sensor consists of a permanent magnet and Hall IC.

When the engine is running, the high and low parts of the teeth cause the gap with the sensor to change.

The changing gap causes the magnetic field near the sensor to change.

Due to the changing magnetic field, the voltage from the sensor changes.

The ECM receives the voltage signal and detects the fluctuation of the engine revolution.

ECM receives the signals as shown in the figure.

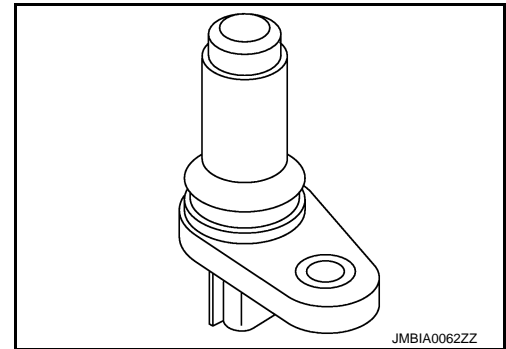

JMBIA0062ZZ

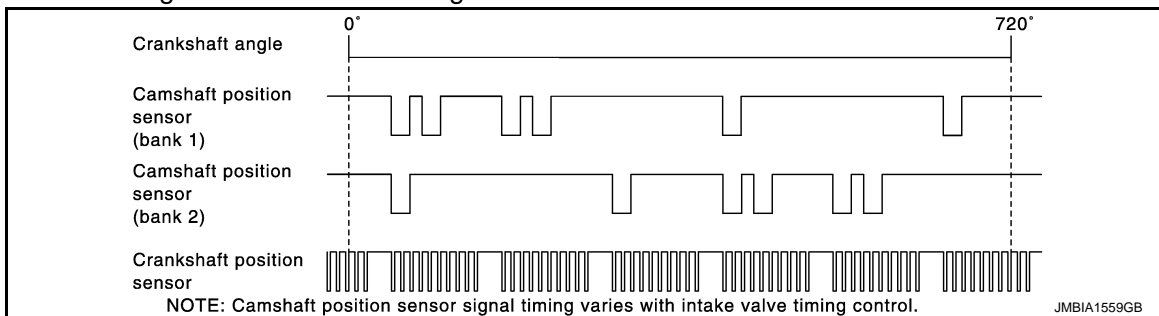

# COMPONENT PARTS

< SYSTEM DESCRIPTION >

[VK56VD FOR USA AND CANADA]

## ECM

INFOID:000000007187154

- ECM (Engine Control Module) controls the engine.
- The ECM consists of a microcomputer and connectors for transmitting/receiving signals and for supplying power. Furthermore, the ECM is equipped with an injector driver unit and actuates the fuel injector at a high voltage (approximately 70 V at the maximum).
- ECM is equipped with ECM temperature sensors. If ECM is overheated, ECM controls output torque to prevent damage to itself.
- Battery voltage is supplied to the ECM even when the ignition switch is turned OFF for the ECM memory function of the DTC memory, the air-fuel ratio feedback compensation value memory, the idle air volume learning value memory, etc.

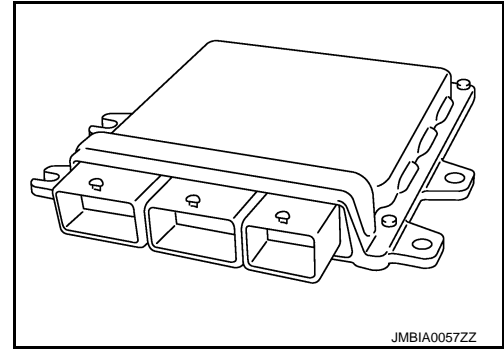

## Electric Throttle Control Actuator

INFOID:000000007187155

### OUTLINE

Electric throttle control actuator consists of throttle body, throttle valve, throttle control motor and throttle position sensor.

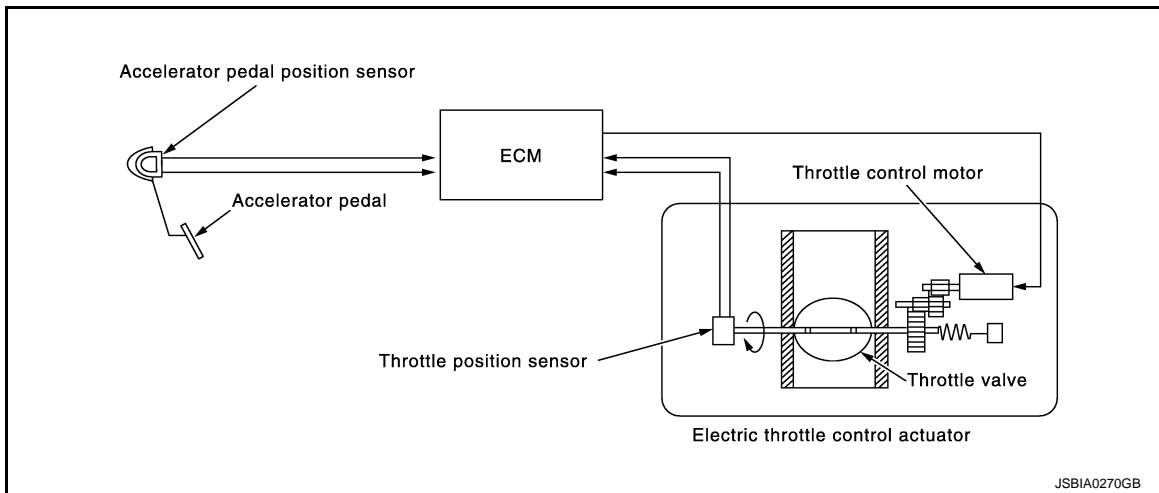

### THROTTLE CONTROL MOTOR

The throttle control motor is operated by the ECM and it opens and closes the throttle valve. The current opening angle of the throttle valve is detected by the throttle position sensor. The throttle position sensor provides feedback to the ECM, when opens/closes the throttle valve in response to driving conditions via the throttle control motor.

### THROTTLE POSITION SENSOR

The throttle position sensor responds to the throttle valve movement. The throttle position sensor has two sensors. These sensors are a kind of potentiometer which transform the throttle valve position into output voltage, and emit the voltage signal to the ECM. The ECM judges the current opening angle of the throttle valve from these signals and controls the throttle valve opening angle in response to driving conditions via the throttle control motor.

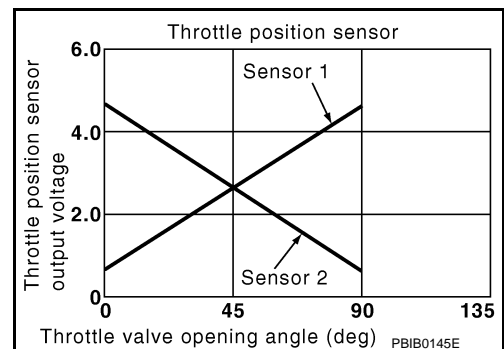

# COMPONENT PARTS

< SYSTEM DESCRIPTION >

[VK56VD FOR USA AND CANADA]

## Engine Coolant Temperature Sensor

INFOID:000000007187156

The engine coolant temperature sensor is used to detect the engine coolant temperature. The sensor modifies a voltage signal from the ECM. The modified signal returns to the ECM as the engine coolant temperature input. The sensor uses a thermistor which is sensitive to the change in temperature. The electrical resistance of the thermistor decreases as temperature increases.

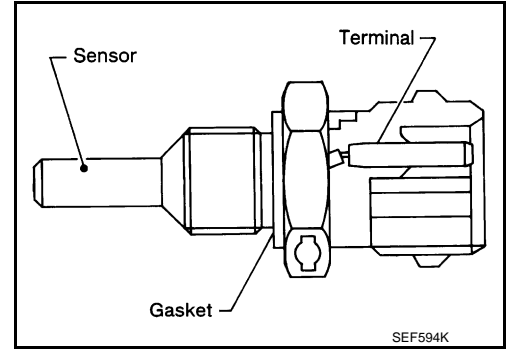

### <Reference data>

| Engine coolant temperature<br>[°C (°F)] | Voltage* (V) | Resistance (kΩ) |
|---|--------------|-----------------|
| -10 (14)                                | 4.4          | 7.0 - 11.4      |
| 20 (68)                                 | 3.5          | 2.1 - 2.9       |
| 50 (122)                                | 2.2          | 0.68 - 1.00     |
| 90 (194)                                | 0.9          | 0.236 - 0.260   |

\*: These data are reference values and are measured between ECM terminals.

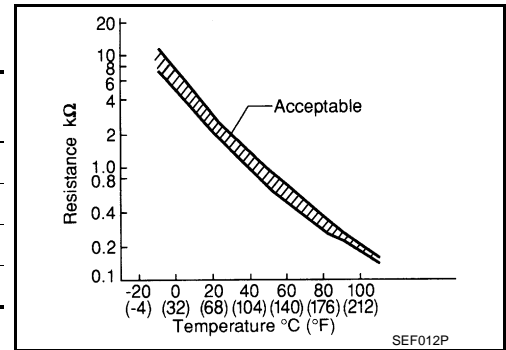

## Engine Oil Pressure Sensor

INFOID:000000007187157

The engine oil pressure (EOP) sensor is detects engine oil pressure and transmits a voltage signal to the ECM.

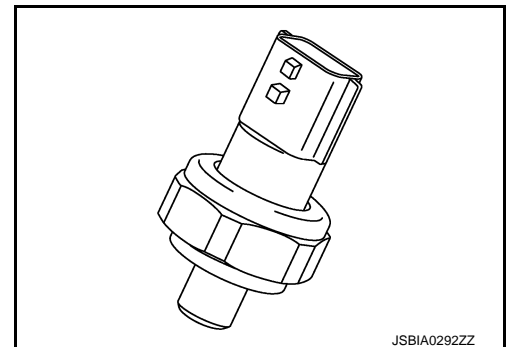

## Engine Oil Temperature Sensor

INFOID:000000007187158

The engine oil temperature sensor is used to detect the engine oil temperature. The sensor modifies a voltage signal from the ECM. The modified signal returns to the ECM as the engine oil temperature input. The sensor uses a thermistor which is sensitive to the change in temperature. The electrical resistance of the thermistor decreases as temperature increases.

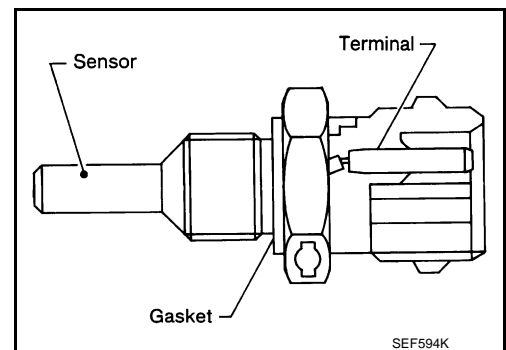



# COMPONENT PARTS

< SYSTEM DESCRIPTION >

[VK56VD FOR USA AND CANADA]

## <Reference data>

| Engine oil temperature<br>[°C (°F)] | Voltage* (V) | Resistance (kΩ) |
|-------------------------------------|--------------|-----------------|
| -10 (14)                            | 4.4          | 7.0 - 11.4      |
| 20 (68)                             | 3.5          | 2.1 - 2.9       |
| 50 (122)                            | 2.2          | 0.68 - 1.00     |
| 90 (194)                            | 0.9          | 0.236 - 0.260   |
| 110 (230)                           | 0.6          | 0.143 - 0.153   |

\*: These data are reference values and are measured between ECM terminals.

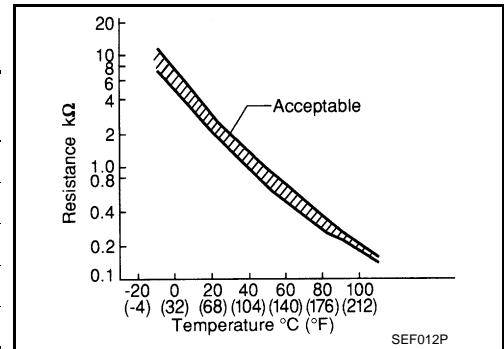

## EVAP Control System Pressure Sensor

INFOID:000000007187159

The EVAP control system pressure sensor detects pressure in the purge line. The sensor output voltage to the ECM increases as pressure increases.

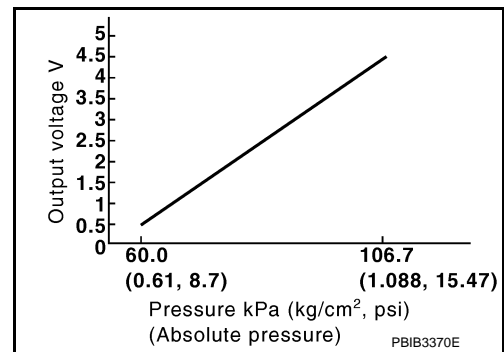

## EVAP Canister Vent Control Valve

INFOID:000000007187160

The EVAP canister vent control valve is located on the EVAP canister and is used to seal the canister vent.

This solenoid valve responds to signals from the ECM. When the ECM sends an ON signal, the coil in the solenoid valve is energized. A plunger then moves to seal the canister vent. The ability to seal the vent is necessary for the on board diagnosis of other evaporative emission control system components.

This solenoid valve is used only for diagnosis, and usually remains opened.

When the vent is closed, under normal purge conditions, the evaporative emission control system is depressurized and allows "EVAP Control System" diagnosis.

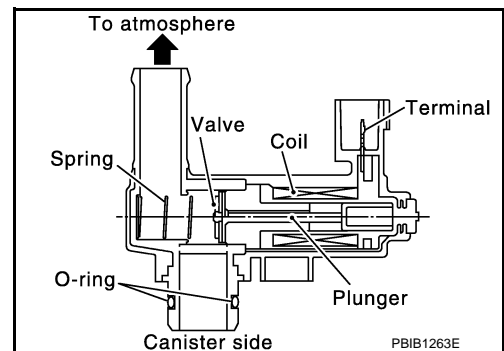

## EVAP Canister Purge Volume Control Solenoid Valve

INFOID:000000007187161

The EVAP canister purge volume control solenoid valve is used to control the flow rate of fuel vapor from the EVAP canister. The EVAP canister purge volume control solenoid valve is moved by ON/OFF pulses from the ECM. The longer the ON pulse, the greater the amount of fuel vapor that will flow through the valve.

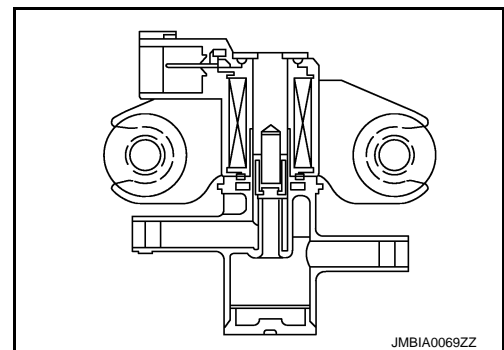

# COMPONENT PARTS

< SYSTEM DESCRIPTION >

[VK56VD FOR USA AND CANADA]

## Exhaust Valve Timing Control Position Sensor

INFOID:000000007187162

Exhaust valve timing control position sensor detects the protrusion of the signal plate installed to the exhaust camshaft front end. This sensor signal is used for sensing a position of the exhaust camshaft.

This sensor uses a Hall IC.

Based on the position of the exhaust camshaft, ECM controls exhaust valve timing control solenoid valve to optimize the shut/open timing of exhaust valve for the driving condition.

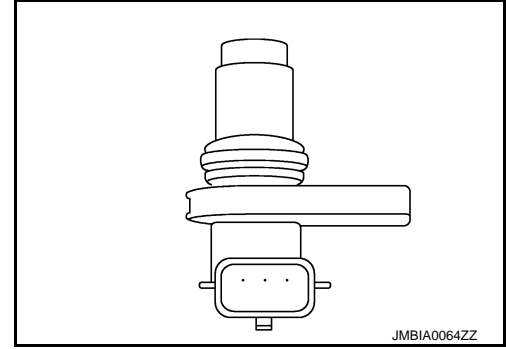

JMBIA0064ZZ

## Exhaust Valve Timing Control Solenoid Valve

INFOID:000000007187163

Exhaust valve timing control solenoid valve is activated by ON/OFF pulse duty (ratio) signals from the ECM.

The exhaust valve timing control solenoid valve changes the oil amount and direction of flow through exhaust valve timing control unit or stops oil flow.

The longer pulse width retards valve angle.

The shorter pulse width advances valve angle.

When ON and OFF pulse widths become equal, the solenoid valve stops oil pressure flow to fix the exhaust valve angle at the control position.

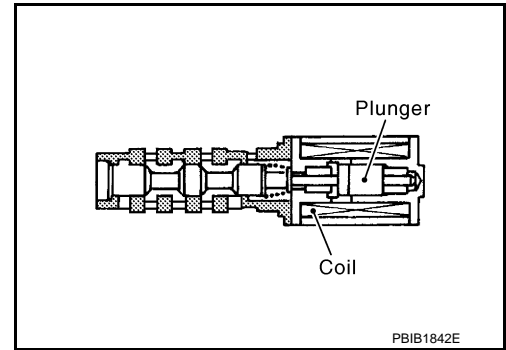

PBIB1842E

## Fuel Injector

INFOID:000000007187164

For the fuel injector, a high pressure fuel injector is used and this enables a high-pressure fuel injection at a high voltage within a short time. The ECM is equipped with an injector driver unit and actuates the fuel injector at a high voltage (approximately 65 V at the maximum).

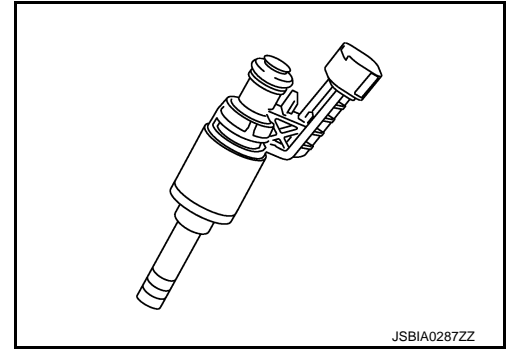

JSBIA0287ZZ

## Fuel Tank Temperature Sensor

INFOID:000000007187165

The fuel tank temperature sensor is used to detect the fuel temperature inside the fuel tank. The sensor modifies a voltage signal from the ECM. The modified signal returns to the ECM as the fuel temperature input. The sensor uses a thermistor which is sensitive to the change in temperature. The electrical resistance of the thermistor decreases as temperature increases.

### <Reference data>

| Fuel temperature [°C (°F)] | Voltage* (V) | Resistance (kΩ) |
|----------------------------|--------------|-----------------|
| 20 (68)                    | 3.5          | 2.3 - 2.7       |
| 50 (122)                   | 2.2          | 0.79 - 0.90     |

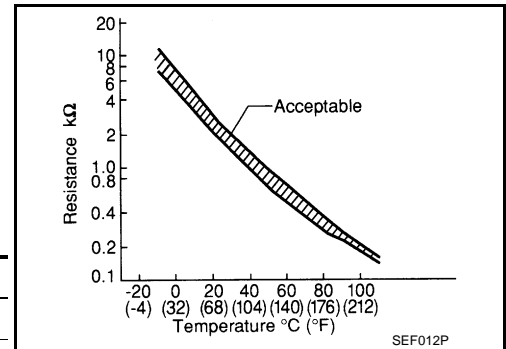

SEF012P

\*: These data are reference values and are measured between ECM terminals.

# COMPONENT PARTS

< SYSTEM DESCRIPTION >

[VK56VD FOR USA AND CANADA]

INFOID:000000007187166

## Heated Oxygen Sensor 2

### DESCRIPTION

The heated oxygen sensor 2, after three way catalyst (manifold), monitors the oxygen level in the exhaust gas on each bank.

Even if switching characteristics of the air fuel ratio (A/F) sensor 1 are shifted, the air fuel ratio is controlled to stoichiometric, by the signal from the heated oxygen sensor 2.

This sensor is made of ceramic zirconia. The zirconia generates voltage from approximately 1 V in richer conditions to 0 V in leaner conditions.

Under normal conditions the heated oxygen sensor 2 is not used for engine control operation.

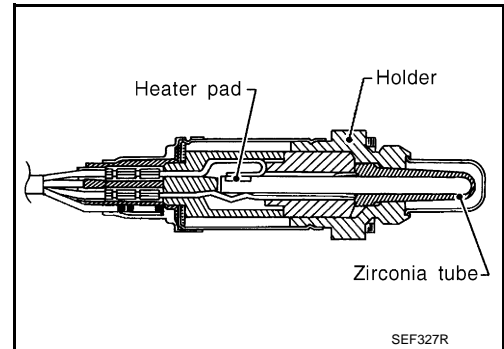

### HEATED OXYGEN SENSOR 2 HEATER

Heated oxygen sensor 2 heater is integrated in the sensor.

The ECM performs ON/OFF control of the heated oxygen sensor 2 heater corresponding to the engine speed, amount of intake air and engine coolant temperature.

| Engine speed   | Heated oxygen sensor 2 heater |
|--|-------------------------------|
| Above 3,600 rpm  | OFF                           |
| Below 3,600 rpm after the following conditions are met. <ul style="list-style-type: none"> <li>• Engine: After warming up</li> <li>• Keeping the engine speed between 3,500 and 4,000 rpm for 1 minute and at idle for 1 minute under no load</li> </ul> | ON                            |

## High Pressure Fuel Pump

INFOID:000000007187167

The high pressure fuel pump is installed at the front of the engine bank 2 side and activated by the camshaft. ECM controls the high pressure fuel pump control solenoid valve built into the high pressure fuel pump and adjusts the amount of discharge by changing the suction timing of the low pressure fuel.

### Operating Description

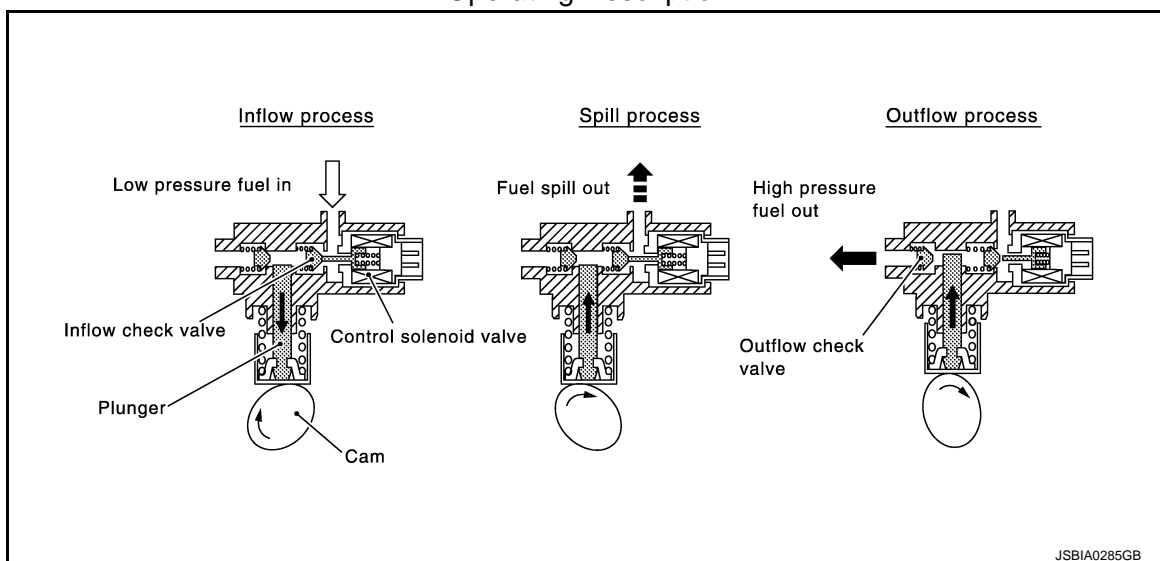

# COMPONENT PARTS

< SYSTEM DESCRIPTION >

[VK56VD FOR USA AND CANADA]

Operating Chart

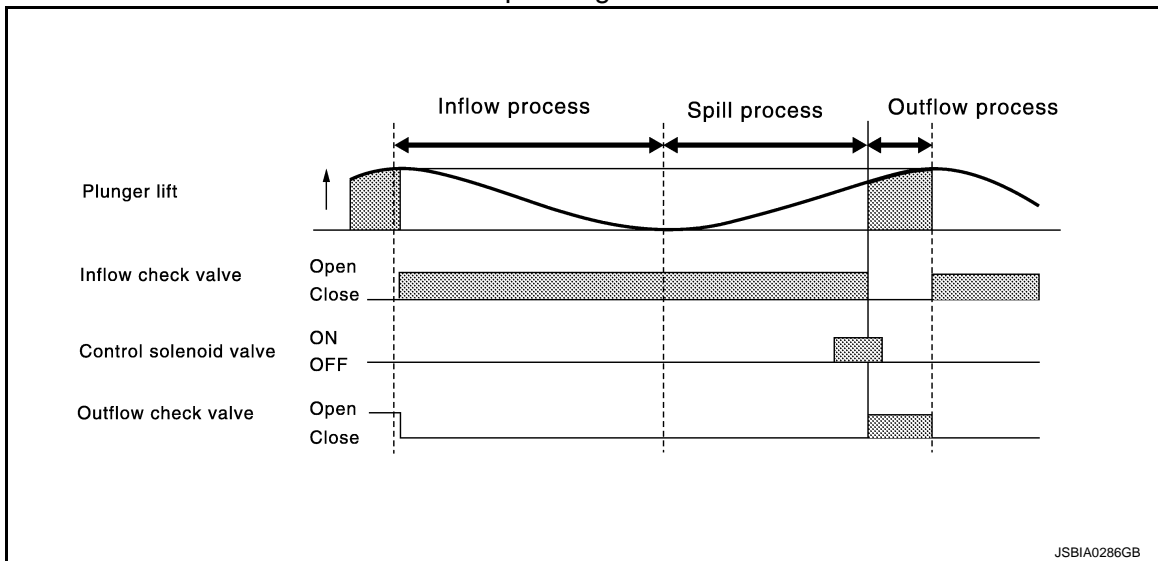

## Fuel Pump Control Module

INFOID:000000007187168

The fuel pump control module (FPCM) controls the discharging volume of the fuel pump by transmitting the FPCM control signals (Low/Mid/High) depending on driving conditions.

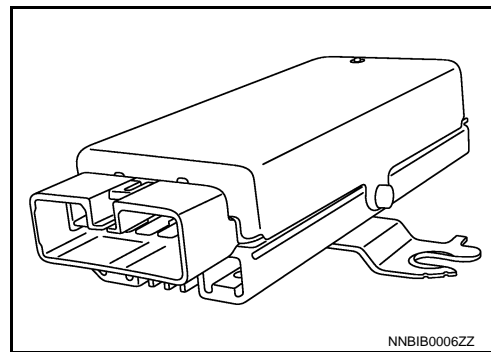

## Fuel Rail Pressure Sensor

INFOID:000000007187169

The fuel rail pressure (FRP) sensor is placed to the fuel rail and measures fuel pressure in the fuel rail. The sensor transmits voltage signal to the ECM. As the pressure increases, the voltage rises. The ECM controls the fuel pressure in the fuel rail by operating high pressure fuel pump. The ECM uses the signal from fuel rail pressure sensor as a feedback signal.

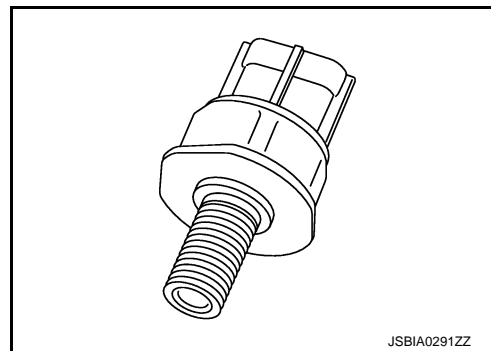

## ICC Brake Switch

INFOID:000000007187170

When the brake pedal is depressed, ICC brake switch is turned OFF and stop lamp switch is turned ON. ECM detects the state of the brake pedal by those two types of input (ON/OFF signal).

## ICC Steering Switch

INFOID:000000007187171

ICC steering switch has variant values of electrical resistance for each button. ECM reads voltage variation of switch, and determines which button is operated.

## Ignition Coil With Power Transistor

INFOID:000000007187172

The ignition signal from the ECM is sent to and amplified by the power transistor. The power transistor turns ON and OFF the ignition coil primary circuit. This ON/OFF operation induces the proper high voltage in the coil secondary circuit.

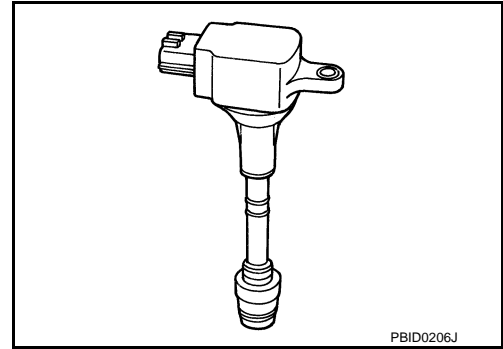

PBID0206J

## Information Display

INFOID:000000007187173

The operation mode of the ASCD is indicated on the information display in the combination meter. When turning ON the MAIN switch of the ASCD steering switch, the CRUISE indicator turns ON, CRUISE is indicated on the information display and the operation mode turns to standby mode. When turning ON the SET/COAST switch while the vehicle is driven at the ASCD setting condition speed range, the SET indicator turns ON and the set speed is indicated on the information display. When the canceling conditions come into effect, CANCEL is indicated on the information display.

## Intake Valve Timing Control Solenoid Valve

INFOID:000000007187174

Intake valve timing control solenoid valve is activated by ON/OFF pulse duty (ratio) signals from the ECM.

The intake valve timing control solenoid valve changes the oil amount and direction of flow through intake valve timing control unit or stops oil flow.

The longer pulse width advances valve angle.

The shorter pulse width retards valve angle.

When ON and OFF pulse widths become equal, the solenoid valve stops oil pressure flow to fix the intake valve angle at the control position.

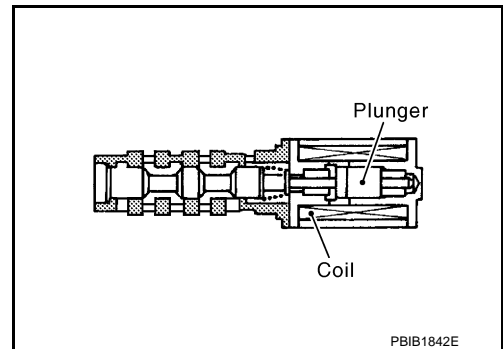

PBIB1842E

## Knock Sensor

INFOID:000000007187175

The knock sensor is attached to the cylinder block. It senses engine knocking using a piezoelectric element. A knocking vibration from the cylinder block is sensed as vibrational pressure. This pressure is converted into a voltage signal and sent to the ECM.

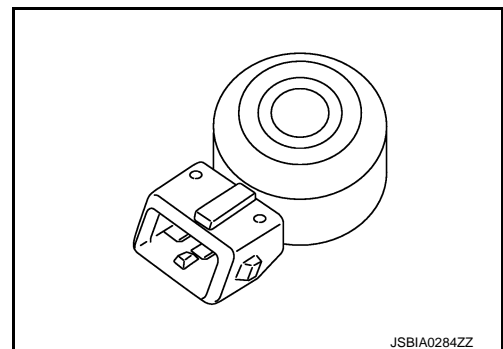

JSBIA0284ZZ

A  
EC  
C  
D  
E  
F  
G  
H  
I  
J  
K  
L  
M  
N  
O  
P

# COMPONENT PARTS

< SYSTEM DESCRIPTION >

[VK56VD FOR USA AND CANADA]

## Low Fuel Pressure Sensor

INFOID:000000007187176

The low fuel pressure sensor is installed to low fuel pressure piping and measures the low fuel pressure. The sensor transmits voltage signal to the ECM. As the pressure increases, the voltage rises.

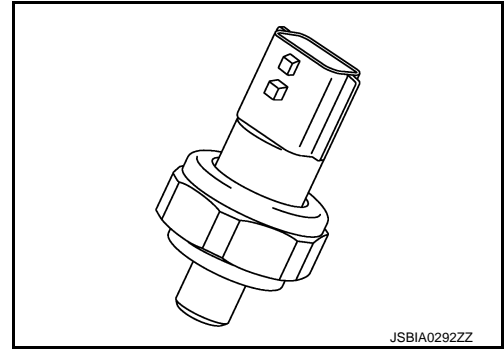

## Low Pressure Fuel Pump

INFOID:000000007187177

The low pressure fuel pump is integrated with a fuel pressure regulator and a fuel filter. This pump is built into the fuel tank. ECM controls the low pressure fuel pump via FPCM.

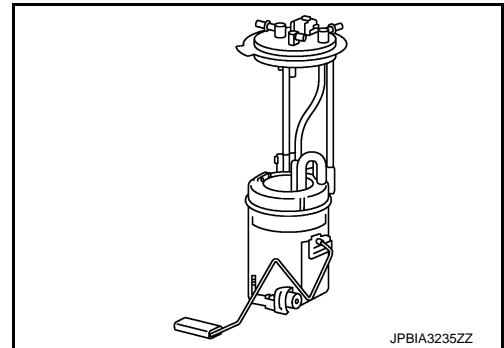

## Malfunction Indicator Lamp (MIL)

INFOID:000000007187178

The Malfunction Indicator Lamp (MIL) is located on the combination meter.

The MIL will illuminate when the ignition switch is turned ON without the engine running. This is a bulb check.

When the engine is started, the MIL should turn off. If the MIL remains illuminated, the on board diagnostic system has detected an engine system malfunction.

For details, refer to [EC-1033, "Diagnosis Description"](#).

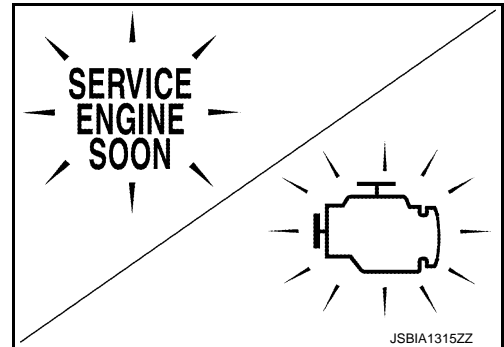

## Manifold Absolute Pressure Sensor

INFOID:000000007187179

The manifold absolute pressure (MAP) sensor is installed on the intake manifold collector. Detects intake manifold pressure, and transmits a voltage signal to the ECM.

The sensor uses a silicon diaphragm which is sensitive to the change in pressure. As the pressure increases, the voltage rises.

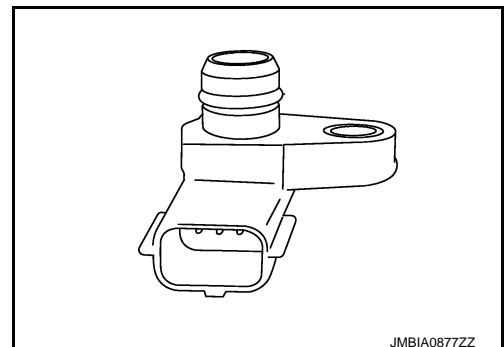

## Mass Air Flow Sensor (With Intake Air Temperature Sensor)

INFOID:000000007187180

## MASS AIR FLOW SENSOR

# COMPONENT PARTS

## < SYSTEM DESCRIPTION >

[VK56VD FOR USA AND CANADA]

The mass air flow sensor (1) is placed in the stream of intake air. It measures the intake flow rate by measuring a part of the entire intake flow. The mass air flow sensor controls the temperature of the hot wire to a certain amount. The heat generated by the hot wire is reduced as the intake air flows around it. The greater air flow, the greater the heat loss.

Therefore, the electric current supplied to hot wire is changed to maintain the temperature of the hot wire as air flow increases. The ECM detects the air flow by means of this current change.

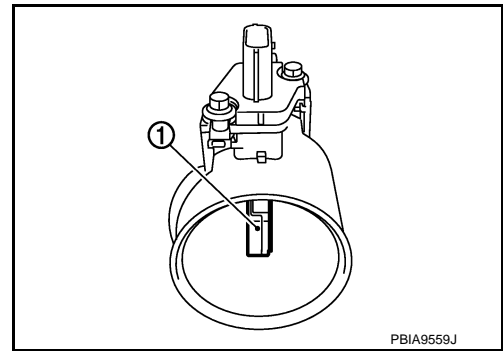

### INTAKE AIR TEMPERATURE SENSOR

The intake air temperature sensor is built-into the mass air flow sensor. The sensor detects intake air temperature and transmits a signal to the ECM.

The temperature sensing unit uses a thermistor which is sensitive to the change in temperature. Electrical resistance of the thermistor decreases in response to the rise in temperature.

#### <Reference data>

| Intake air temperature<br>[°C (°F)] | Voltage* (V) | Resistance (kΩ) |
|-------------------------------------|--------------|-----------------|
| 25 (77)                             | 3.3          | 1.94 - 2.06     |
| 80 (176)                            | 1.2          | 0.293 - 0.349   |

\*: These data are reference values and are measured between ECM terminals.

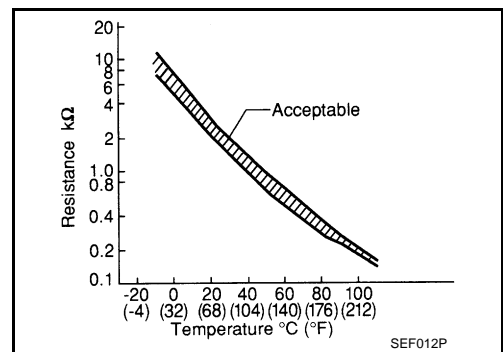

### Power Steering Pressure (PSP) Sensor

INFOID:000000007187181

Power steering pressure (PSP) sensor is installed to the power steering high-pressure tube and detects a power steering load.

This sensor is a potentiometer which transforms the power steering load into output voltage, and emits the voltage signal to the ECM. The ECM controls the electric throttle control actuator and adjusts the throttle valve opening angle to increase the engine speed and adjusts the idle speed for the increased load.

### Refrigerant Pressure Sensor

INFOID:000000007187182

The refrigerant pressure sensor is installed at the condenser of the air conditioner system. The sensor uses an electrostatic volume pressure transducer to convert refrigerant pressure to voltage. The voltage signal is sent to ECM, and ECM controls cooling fan system.

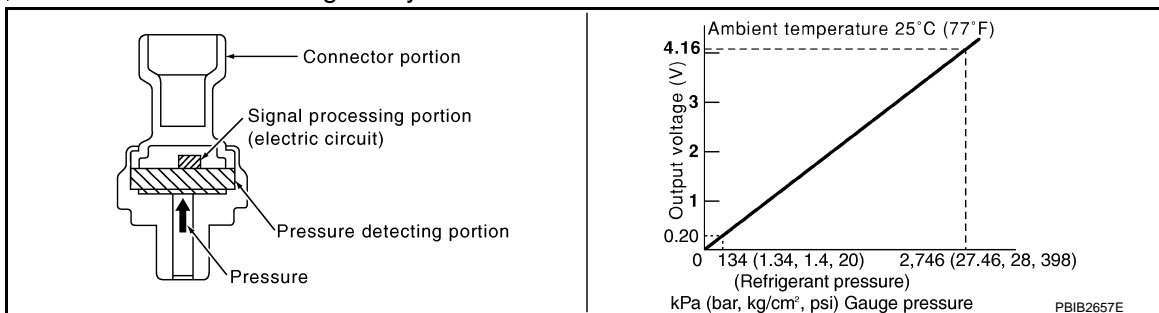

### Stop Lamp Switch

INFOID:000000007187183

Brake switch signal is applied to the ECM through the stop lamp switch when the brake pedal is depressed. This signal is used mainly to decrease the engine speed when the vehicle is being driven.

### < SYSTEM DESCRIPTION >

#### VVEL Actuator Motor

INFOID:000000007187184

The VVEL actuator motor rotates the control shaft according to the control signal from the VVEL control module. The VVEL control module judges whether the VVEL actuator motor controls the angle properly by the VVEL control shaft position sensor signal.

#### VVEL Actuator Motor Relay

INFOID:000000007187185

Power supply for the VVEL actuator motor is provided to the VVEL control module via VVEL actuator motor relay. VVEL actuator motor relay is ON/OFF controlled by the VVEL control module. In addition, when the VVEL actuator motor relay cannot be controlled by the VVEL control module for some reason, it ON/OFF controlled by ECM.

#### VVEL Control Module

INFOID:000000007187186

The VVEL control module consists of a microcomputer and connectors for signal input and output and for power supply. The VVEL control module controls VVEL system.

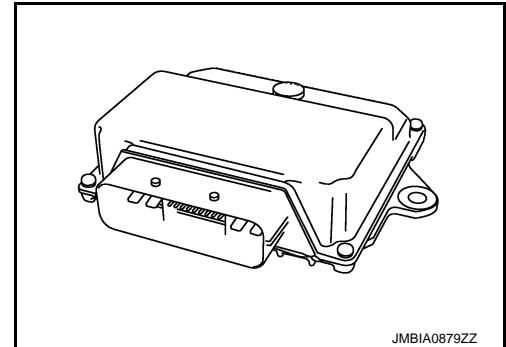

#### VVEL Control Shaft Position Sensor

INFOID:000000007187187

VVEL control shaft position sensor (1) is placed on VVEL actuator sub assembly and detects the control shaft position angle. A magnet is pressed into the arm on the edge of control shaft. The magnetic field changes as the magnet rotates together with the arm resulting in the output voltage change of the sensor. VVEL control module detects the actual position angle through the voltage change and sends the signal to ECM.

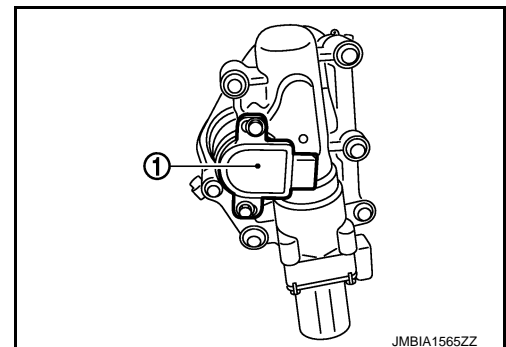



# STRUCTURE AND OPERATION

< SYSTEM DESCRIPTION >

[VK56VD FOR USA AND CANADA]

## STRUCTURE AND OPERATION

### Positive Crankcase Ventilation

INFOID:000000007187188

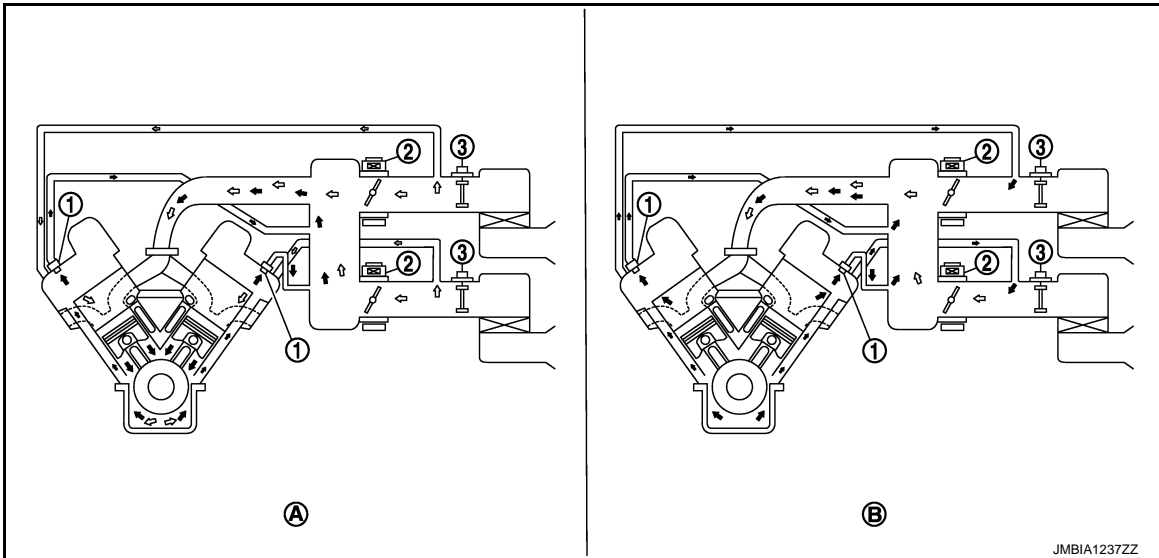

- 1. PCV valve
  - 2. Electric throttle control actuator
  - 3. Mass air flow sensor
- A. Normal condition      B. Hi-load condition

⇐: Fresh air

⇐: Blow-by air

This system returns blow-by gas to the intake manifold.

The positive crankcase ventilation (PCV) valve is provided to conduct crankcase blow-by gas to the intake manifold.

During partial throttle operation of the engine, the intake manifold sucks the blow-by gas through the PCV valve.

Normally, the capacity of the valve is sufficient to handle any blow-by and a small amount of ventilating air. The ventilating air is drawn from the air inlet tubes into the crankcase. In this process the air passes through the hose connecting air inlet tubes to rocker cover.

Under full-throttle condition, the manifold vacuum is insufficient to draw the blow-by flow through the valve. The flow goes through the hose connection in the reverse direction.

On vehicles with an excessively high blow-by, the valve does not meet the requirement. This is because some of the flow will go through the hose connection to the air inlet tubes under all conditions.

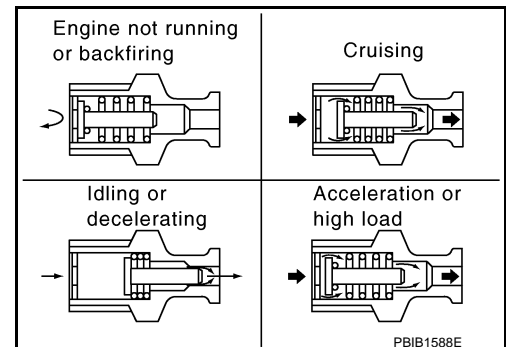

# STRUCTURE AND OPERATION

< SYSTEM DESCRIPTION >

[VK56VD FOR USA AND CANADA]

## On Board Refueling Vapor Recovery (ORVR)

INFOID:000000007187189

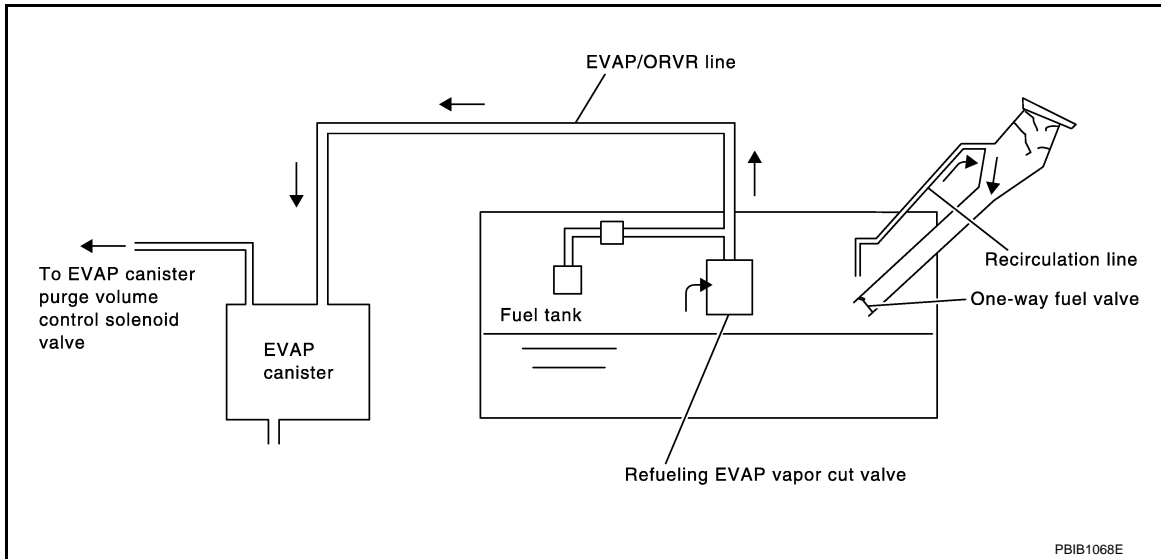

From the beginning of refueling, the air and vapor inside the fuel tank go through refueling EVAP vapor cut valve and EVAP/ORVR line to the EVAP canister. The vapor is absorbed by the EVAP canister and the air is released to the atmosphere.

When the refueling has reached the full level of the fuel tank, the refueling EVAP vapor cut valve is closed and refueling is stopped because of auto shut-off. The vapor which was absorbed by the EVAP canister is purged during driving.

### **WARNING:**

**When conducting inspections below, be sure to observe the following:**

- Put a “CAUTION: FLAMMABLE” sign in workshop.
- Never smoke while servicing fuel system. Keep open flames and sparks away from work area.
- Always furnish the workshop with a CO<sub>2</sub> fire extinguisher.

### **CAUTION:**

- Before removing fuel line parts, carry out the following procedures:
  - Put drained fuel in an explosion-proof container and put lid on securely.
  - Release fuel pressure from fuel line. Refer to [EC-1127, "Work Procedure"](#).
  - Disconnect battery ground cable.
- Always replace O-ring when the fuel gauge retainer is removed.
- Never kink or twist hose and tube when they are installed.
- Never tighten hose and clamps excessively to avoid damaging hoses.
- After installation, run engine and check for fuel leaks at connections.
- Never attempt to top off the fuel tank after the fuel pump nozzle shuts off automatically. Continued refueling may cause fuel overflow, resulting in fuel spray and possibly a fire.

< SYSTEM DESCRIPTION >

SYSTEM  
ENGINE CONTROL SYSTEM

ENGINE CONTROL SYSTEM : System Diagram

INFOID:000000007187190

A

EC

C

D

E

F

G

H

I

J

K

L

M

N

O

P

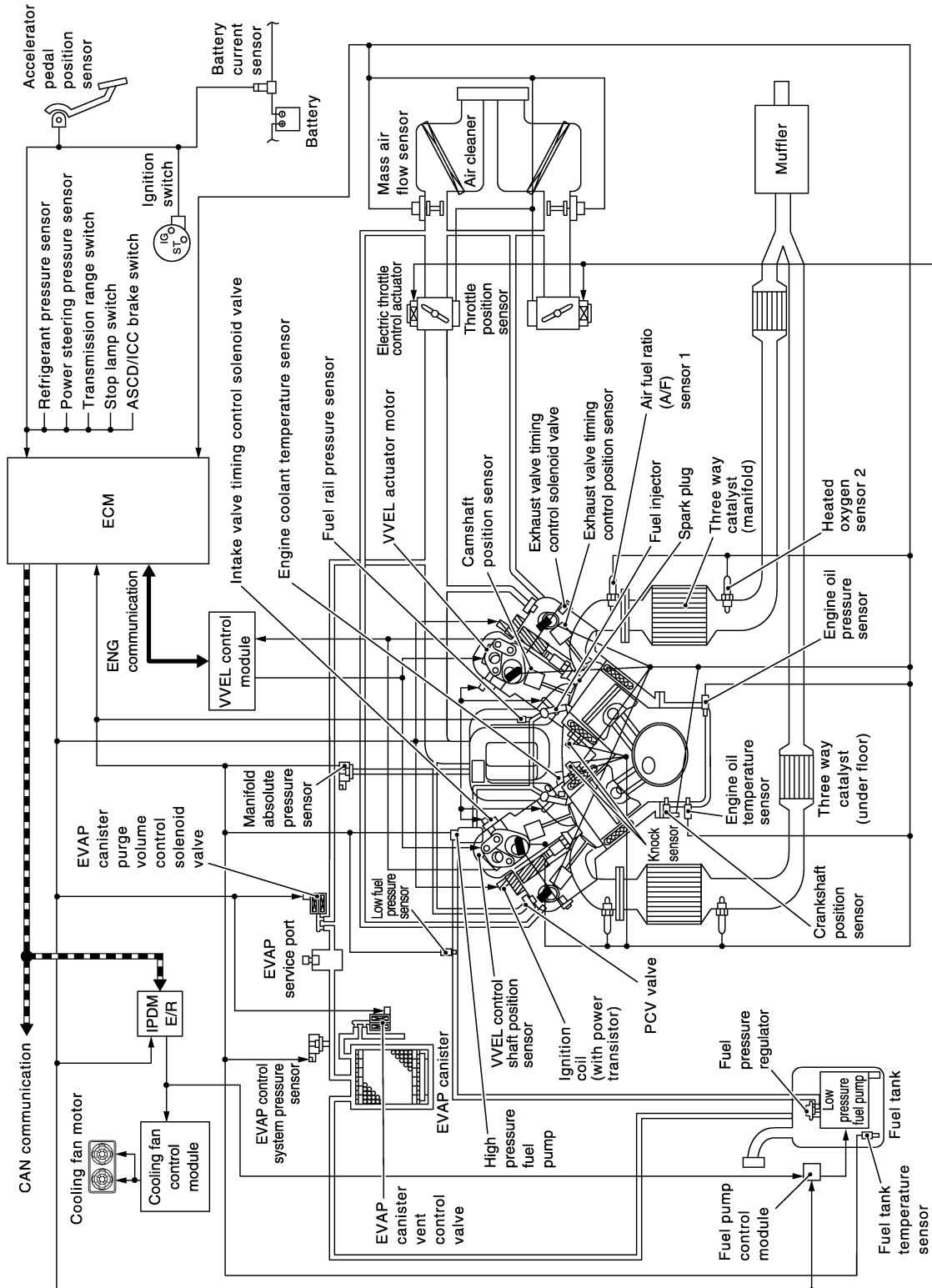

JSBIA0368GB

ENGINE CONTROL SYSTEM : System Description

INFOID:000000007187191

ECM performs various controls such as fuel injection control and ignition timing control.

# SYSTEM

< SYSTEM DESCRIPTION >

[VK56VD FOR USA AND CANADA]

## DIRECT INJECTION GASOLINE SYSTEM

### DIRECT INJECTION GASOLINE SYSTEM : System Diagram

INFOID:000000007187192

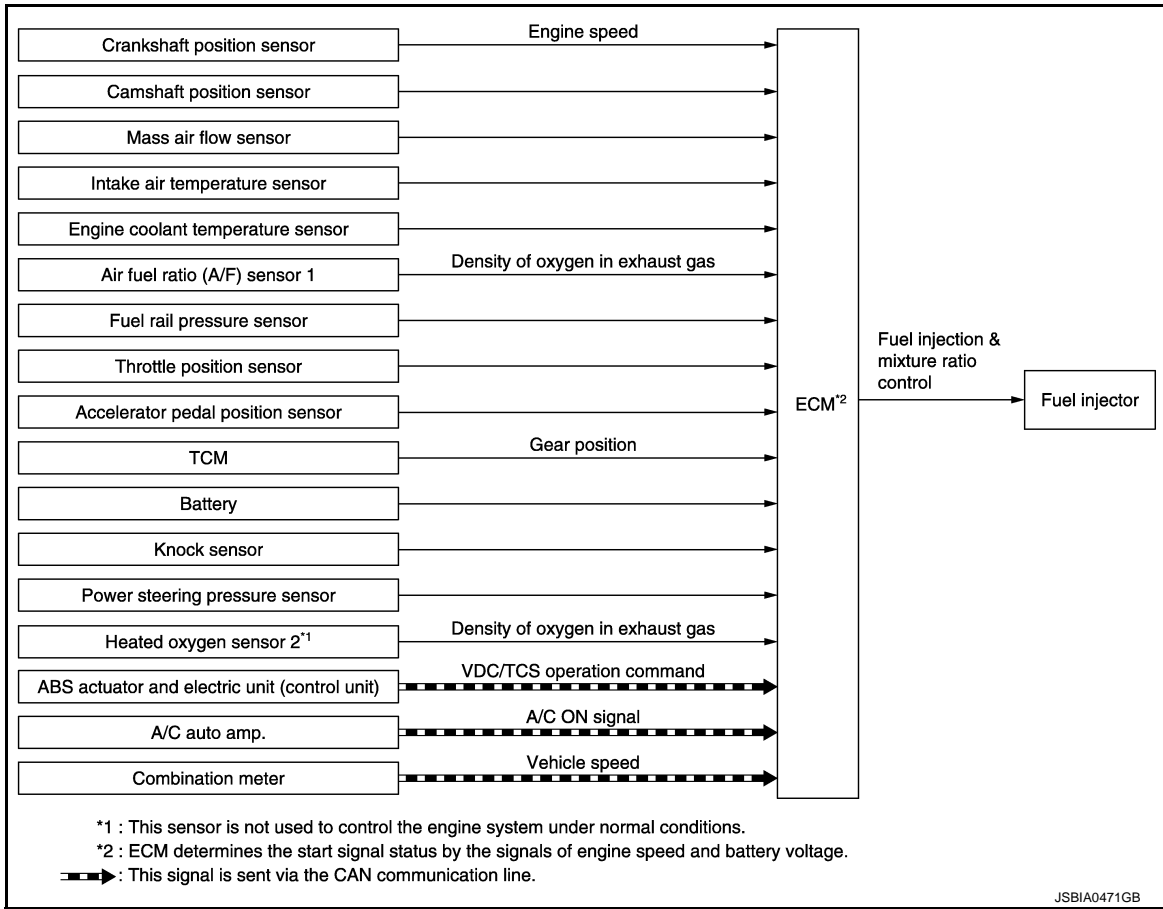

### DIRECT INJECTION GASOLINE SYSTEM : System Description

INFOID:000000007187193

#### INPUT/OUTPUT SIGNAL CHART

# SYSTEM

< SYSTEM DESCRIPTION >

[VK56VD FOR USA AND CANADA]

| Sensor  | Input signal to ECM               | ECM function                           | Actuator      |    |
|---|-----------------------------------|--|---------------|----|
| Crankshaft position sensor                    | Engine speed*2                    | Fuel injection & mixture ratio control | Fuel injector | A  |
| Camshaft position sensor                      | Camshaft position                 |  |               | EC |
| Mass air flow sensor                          | Amount of intake air              |  |               | C  |
| Intake air temperature sensor                 | Intake air temperature            |  |               | D  |
| Engine coolant temperature sensor             | Engine coolant temperature        |  |               | E  |
| Air fuel ratio (A/F) sensor 1                 | Density of oxygen in exhaust gas  |  |               | F  |
| Fuel rail pressure sensor                     | Fuel rail pressure                |  |               | G  |
| Throttle position sensor                      | Throttle position                 |  |               | H  |
| Accelerator pedal position sensor             | Accelerator pedal position        |  |               | I  |
| TCM   | Park/neutral position             |  |               | J  |
| Battery                                       | Battery voltage*2                 |  |               | K  |
| Knock sensor                                  | Engine knocking condition         |  |               | L  |
| Power steering pressure sensor                | Power steering operation          |  |               | M  |
| Heated oxygen sensor 2*1                      | Density of oxygen in exhaust gas  |  |               | N  |
| ABS actuator and electric unit (control unit) | VDC/TCS operation command         |  |               | O  |
| A/C auto amp.                                 | A/C ON signal<br>Blower ON signal |  |               | P  |
| Combination meter                             | Vehicle speed                     |  |               |    |

\*1: This sensor is not used to control the engine system under normal conditions.

\*2: ECM determines the start signal status by the signals of engine speed and battery voltage.

## SYSTEM DESCRIPTION

The adoption of the direct fuel injection method enables more accurate adjustment of fuel injection quantity by injecting atomized high-pressure fuel directly into the cylinder. This method allows high-powered engine, low fuel consumption, and emissions-reduction.

The amount of fuel injected from the fuel injector is determined by the ECM. The ECM controls the length of time the valve remains open (injection pulse duration). The amount of fuel injected is a program value in the ECM memory. The program value is preset by engine operating conditions. These conditions are determined by input signals (for engine speed and intake air and fuel rail pressure) from the crankshaft position sensor, camshaft position sensor, mass air flow sensor and the fuel rail pressure sensor.

## VARIOUS FUEL INJECTION INCREASE/DECREASE COMPENSATION

In addition, the amount of fuel injected is compensated to improve engine performance under various operating conditions as listed below.

<Fuel increase>

- During warm-up
- When starting the engine
- During acceleration
- Hot-engine operation
- When selector lever position is changed from N to D
- High-load, high-speed operation

<Fuel decrease>

- During deceleration
- During high engine speed operation

## FUEL INJECTION CONTROL

### Stratified-charge Combustion

Stratified-charge combustion is a combustion method which enables extremely lean combustion by injecting fuel in the latter half of a compression process, collecting combustible air-fuel around the spark plug, and forming fuel-free airspace around the mixture.

Right after a start with the engine cold, the catalyst warm-up is accelerated by stratified-charge combustion.

## Homogeneous Combustion

Homogeneous combustion is a combustion method that fuel is injected during intake process so that combustion occurs in the entire combustion chamber, as is common with conventional methods.

As for a start except for starts with the engine cold, homogeneous combustion occurs.

## MIXTURE RATIO FEEDBACK CONTROL (CLOSED LOOP CONTROL)

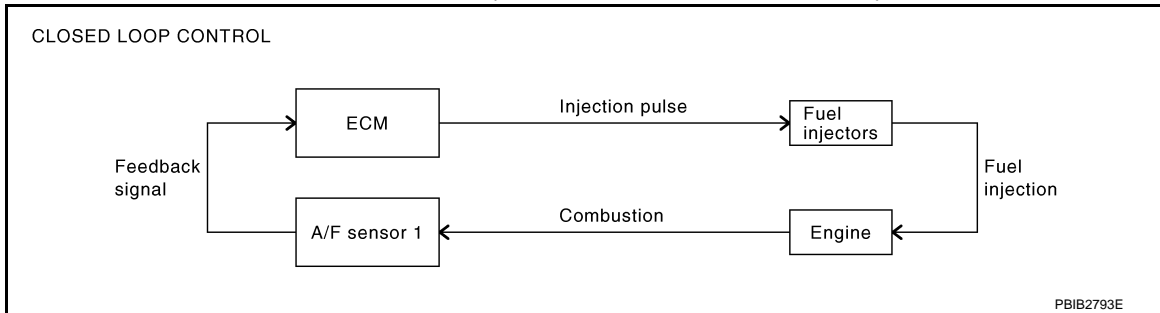

The mixture ratio feedback system provides the best air-fuel mixture ratio for driveability and emission control. The three way catalyst (manifold) can better reduce CO, HC and NOx emissions. This system uses A/F sensor 1 in the exhaust manifold to monitor whether the engine operation is rich or lean. The ECM adjusts the injection pulse width according to the sensor voltage signal. For more information about A/F sensor 1, refer to [EC-996, "Air Fuel Ratio \(A/F\) Sensor 1"](#). This maintains the mixture ratio within the range of stoichiometric (ideal air-fuel mixture).

This stage is referred to as the closed loop control condition.

Heated oxygen sensor 2 is located downstream of the three way catalyst (manifold). Even if the switching characteristics of A/F sensor 1 shift, the air-fuel ratio is controlled to stoichiometric by the signal from heated oxygen sensor 2.

### • Open Loop Control

The open loop system condition refers to when the ECM detects any of the following conditions. Feedback control stops in order to maintain stabilized fuel combustion.

- Deceleration and acceleration
- High-load, high-speed operation
- Malfunction of A/F sensor 1 or its circuit
- Insufficient activation of A/F sensor 1 at low engine coolant temperature
- High engine coolant temperature
- During warm-up
- After shifting from N to D
- When starting the engine

## MIXTURE RATIO SELF-LEARNING CONTROL

The mixture ratio feedback control system monitors the mixture ratio signal transmitted from A/F sensor 1. This feedback signal is then sent to the ECM. The ECM controls the basic mixture ratio as close to the theoretical mixture ratio as possible. However, the basic mixture ratio is not necessarily controlled as originally designed. Both manufacturing differences (i.e., mass air flow sensor hot wire) and characteristic changes during operation (i.e., fuel injector clogging) directly affect mixture ratio.

Accordingly, the difference between the basic and theoretical mixture ratios is monitored in this system. This is then computed in terms of "injection pulse duration" to automatically compensate for the difference between the two ratios.

"Fuel trim" refers to the feedback compensation value compared against the basic injection duration. Fuel trim includes "short-term fuel trim" and "long-term fuel trim".

"Short term fuel trim" is the short-term fuel compensation used to maintain the mixture ratio at its theoretical value. The signal from A/F sensor 1 indicates whether the mixture ratio is RICH or LEAN compared to the theoretical value. The signal then triggers a reduction in fuel volume if the mixture ratio is rich, and an increase in fuel volume if it is lean.

"Long-term fuel trim" is overall fuel compensation carried out over time to compensate for continual deviation of the "short-term fuel trim" from the central value. Continual deviation will occur due to individual engine differences, wear over time and changes in the usage environment.

## FUEL INJECTION TIMING

Sequential Direct Injection Gasoline System

# SYSTEM

## < SYSTEM DESCRIPTION >

[VK56VD FOR USA AND CANADA]

Fuel is injected into each cylinder during each engine cycle according to the ignition order.

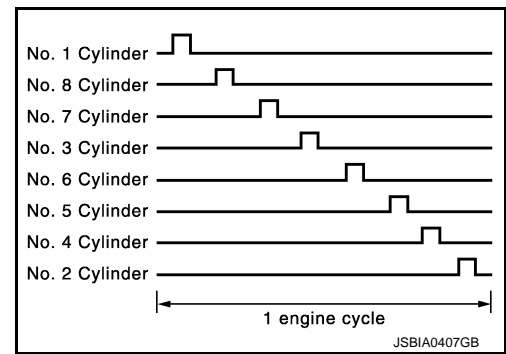

### STRATIFIED-CHARGE START CONTROL

The use of the stratified-charge combustion method enables emissions-reduction when starting the engine with engine coolant temperature between 5°C (41°F) and 40°C (104°F).

### FUEL SHUT-OFF

Fuel to each cylinder is shut-off during deceleration, operation of the engine at excessively high speed or operation of the vehicle at excessively high speed.

### FUEL PRESSURE CONTROL

### FUEL PRESSURE CONTROL : System Diagram

INFOID:000000007187194

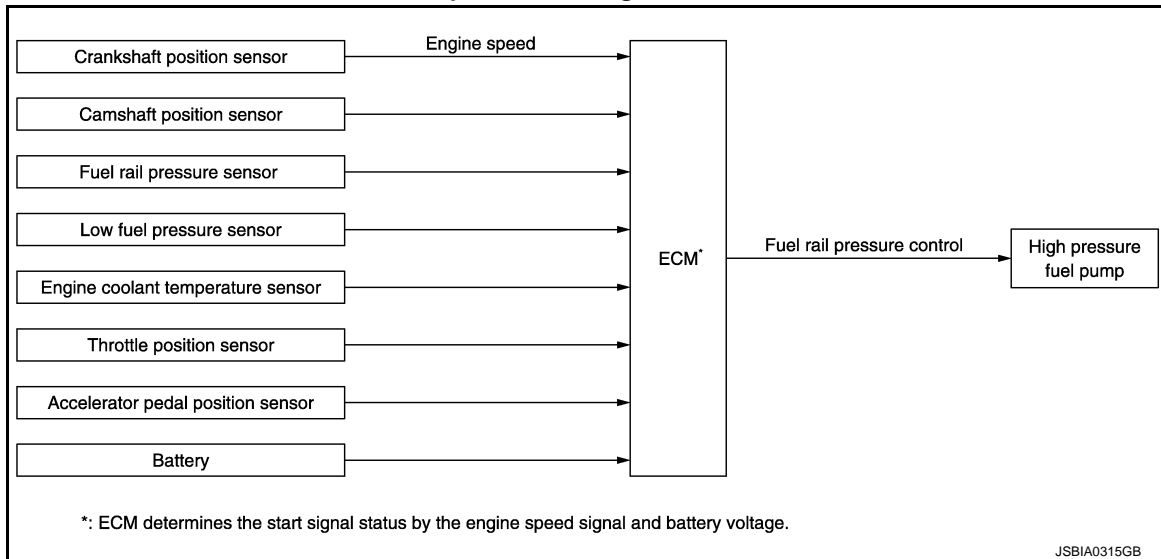

### FUEL PRESSURE CONTROL : System Description

INFOID:000000007187195

### INPUT/OUTPUT SIGNAL CHART

| Sensor                            | Input signal to ECM        | ECM function                           | Actuator      |
|-----------------------------------|----------------------------|--|---------------|
| Crankshaft position sensor        | Engine speed               | Fuel injection & mixture ratio control | Fuel injector |
| Camshaft position sensor          | Camshaft position          |  |               |
| Fuel rail pressure sensor         | Fuel rail pressure         |  |               |
| Low fuel pressure sensor          | Low fuel pressure          |  |               |
| Engine coolant temperature sensor | Engine coolant temperature |  |               |
| Throttle position sensor          | Throttle position          |  |               |
| Accelerator pedal position sensor | Accelerator pedal position |  |               |
| Battery                           | Battery voltage            |  |               |

# SYSTEM

< SYSTEM DESCRIPTION >

[VK56VD FOR USA AND CANADA]

## SYSTEM DESCRIPTION

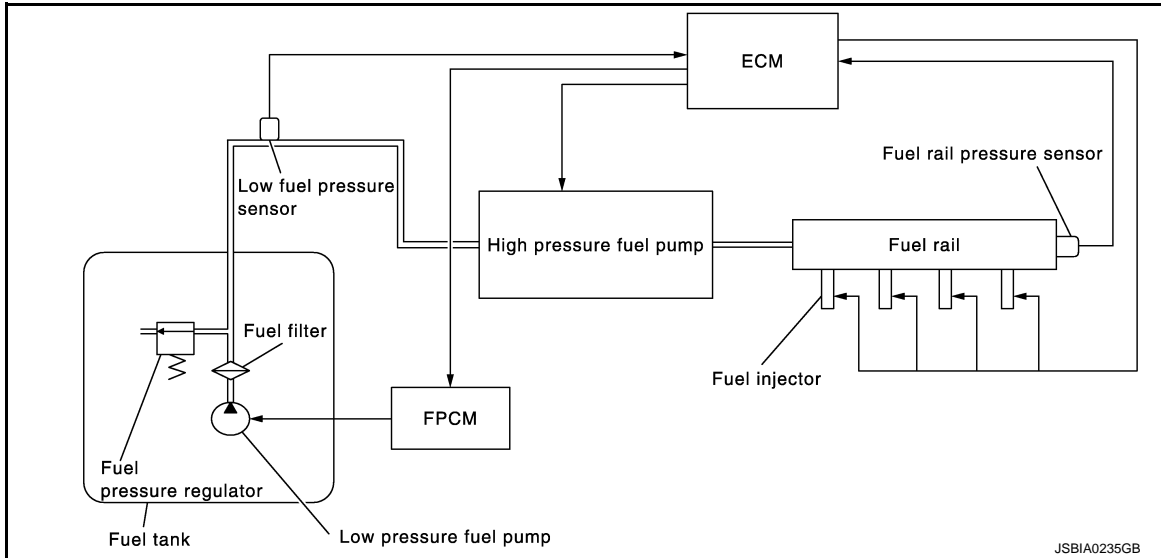

### Low fuel pressure control

- The low fuel pressure pump is controlled by the fuel pump control module (FPCM) and pumps fuel according to a driving condition. The pumped fuel passes through the fuel filter and is sent to the high pressure fuel pump. FPCM controls the low pressure fuel pump, according to a signal from ECM as shown in the table below.

| Conditions  | Amount of fuel flow | Supplied voltage               |
|---|---------------------|--------------------------------|
| After a laps of 1 second after ignition ON  | OFF                 | 0 V                            |
| <ul style="list-style-type: none"> <li>For 1 second after ignition ON (engine coolant temperature is 5°C (41°F) or less, or 40°C (104°F) or more)</li> <li>For 1 second after turning ignition switch ON</li> <li>Engine is running under low load and low speed conditions</li> </ul>                              | Low                 | Approximately 8.5 V            |
| <ul style="list-style-type: none"> <li>For 1 second after ignition ON (engine coolant temperature is 5°C (41°F) or more, or 40°C (104°F) or less)</li> <li>Engine cranking</li> <li>Engine coolant temperature is below 10°C (50°F)</li> <li>Engine is running under high load and high speed conditions</li> </ul> | High                | Battery voltage<br>(11 – 14 V) |
| Except the above  | Mid                 | Approximately 10 V             |

- Low fuel pressure is adjusted by the fuel pressure regulator.

### High fuel pressure control

The high pressure fuel pump raises the pressure of the fuel sent from the low pressure fuel pump. Actuated by the camshaft, the high pressure fuel pump activates the high pressure fuel pump solenoid based on a signal received from ECM, and adjusts the amount of discharge by changing the timing of closing the inlet check valve to control fuel rail pressure.

## COOLING FAN CONTROL



# SYSTEM

< SYSTEM DESCRIPTION >

[VK56VD FOR USA AND CANADA]

## COOLING FAN CONTROL : System Diagram

INFOID:000000007187196

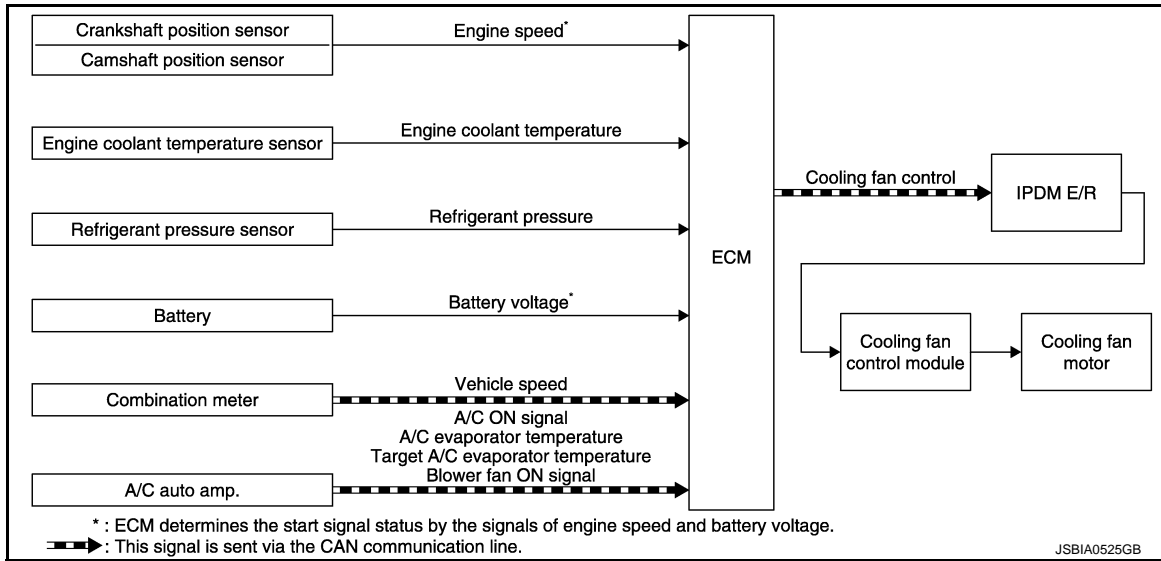

## COOLING FAN CONTROL : System Description

INFOID:000000007187197

### INPUT/OUTPUT SIGNAL CHART

| Sensor   | Input signal to ECM                             | ECM function        | Actuator  |
|--|---|---------------------|---|
| Crankshaft position sensor<br>Camshaft position sensor | Engine speed* <sup>1</sup>                      | Cooling fan control | IPDM E/R<br>↓<br>Cooling fan control module<br>↓<br>Cooling fan motor |
| Engine coolant temperature sensor                      | Engine coolant temperature                      |                     |   |
| Refrigerant pressure sensor                            | Refrigerant pressure                            |                     |   |
| Battery  | Battery voltage* <sup>1</sup>                   |                     |   |
| Combination meter                                      | Vehicle speed* <sup>2</sup>                     |                     |   |
| A/C auto amp.  | A/C ON signal* <sup>2</sup>                     |                     |   |
|  | A/C evaporator temperature* <sup>2</sup>        |                     |   |
|  | Target A/C evaporator temperature* <sup>2</sup> |                     |   |
|  | Blower ON signal                                |                     |   |

\*1: The ECM determines the start signal status by the signals of engine speed and battery voltage.

\*2: This signal is sent to ECM via the CAN communication line.

### SYSTEM DESCRIPTION

ECM controls cooling fan speed corresponding to vehicle speed, engine coolant temperature, air conditioner ON signal, refrigerant pressure, target A/C evaporator temperature and A/C evaporator temperature.

Cooling fan control signal is sent to IPDM E/R from ECM via the CAN communication line. Then, IPDM E/R sends ON/OFF pulse duty signal to cooling fan control module. Corresponding to this ON/OFF pulse duty signal, cooling fan control module gives cooling fan motor operating voltage to cooling fan motors. Cooling fan speed is controlled by duty cycle of cooling fan motor operating voltage sent from cooling fan control module.

### ELECTRIC IGNITION SYSTEM

# SYSTEM

< SYSTEM DESCRIPTION >

[VK56VD FOR USA AND CANADA]

## ELECTRIC IGNITION SYSTEM : System Diagram

INFOID:000000007187198

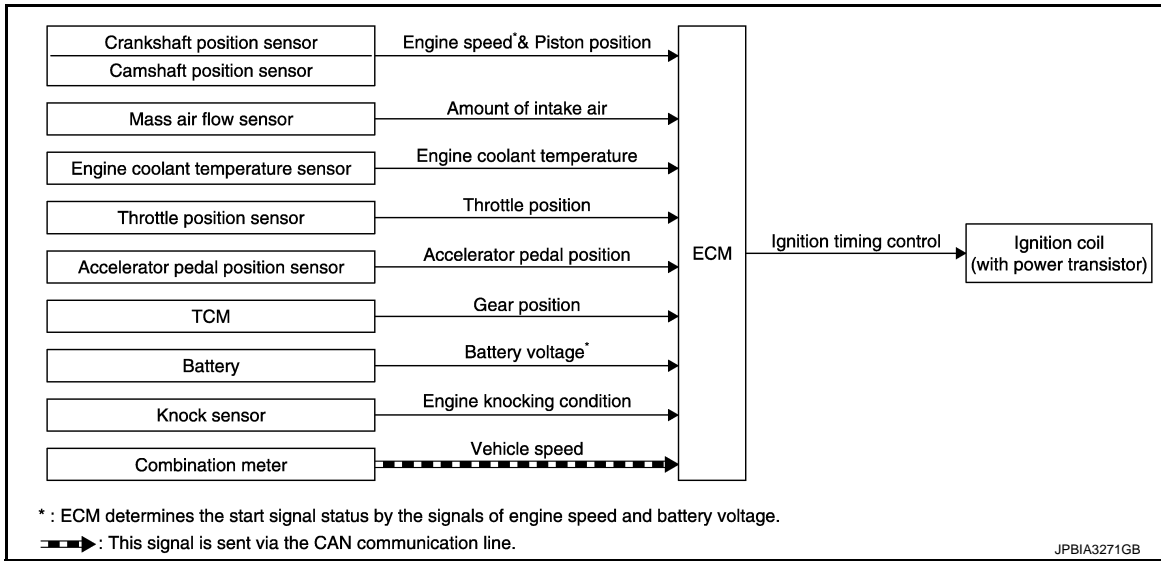

## ELECTRIC IGNITION SYSTEM : System Description

INFOID:000000007187199

### INPUT/OUTPUT SIGNAL CHART

| Sensor                            | Input signal to ECM                           | ECM function            | Actuator                              |
|-----------------------------------|---|-------------------------|---------------------------------------|
| Crankshaft position sensor        | Engine speed* <sup>1</sup><br>Piston position | Ignition timing control | Ignition coil (with power transistor) |
| Camshaft position sensor          |   |                         |                                       |
| Mass air flow sensor              | Amount of intake air                          |                         |                                       |
| Engine coolant temperature sensor | Engine coolant temperature                    |                         |                                       |
| Throttle position sensor          | Throttle position                             |                         |                                       |
| Accelerator pedal position sensor | Accelerator pedal position                    |                         |                                       |
| TCM                               | Gear position                                 |                         |                                       |
| Battery                           | Battery voltage* <sup>1</sup>                 |                         |                                       |
| Knock sensor                      | Engine knocking                               |                         |                                       |
| Combination meter                 | Vehicle speed* <sup>2</sup>                   |                         |                                       |

\*1: ECM determines the start signal status by the signals of engine speed and battery voltage.

\*2: This signal is sent to the ECM via the CAN communication line.

### SYSTEM DESCRIPTION

Ignition order: 1 - 8 - 7 - 3 - 6 - 5 - 4 - 2

The ignition timing is controlled by the ECM to maintain the best air-fuel ratio for every running condition of the engine. The ignition timing data is stored in the ECM.

The ECM receives information such as the injection pulse width and camshaft position sensor signal. Computing this information, ignition signals are transmitted to the power transistor.

During the following conditions, the ignition timing is revised by the ECM according to the other data stored in the ECM.

- At starting
- During warm-up
- At idle
- At low battery voltage
- During acceleration

The knock sensor retard system is designed only for emergencies. The basic ignition timing is programmed within the anti-knocking zone, if recommended fuel is used under dry conditions. The retard system does not operate under normal driving conditions. If engine knocking occurs, the knock sensor monitors the condition. The signal is transmitted to the ECM. The ECM retards the ignition timing to eliminate the knocking condition.

# SYSTEM

< SYSTEM DESCRIPTION >

[VK56VD FOR USA AND CANADA]

## INTAKE VALVE TIMING CONTROL

### INTAKE VALVE TIMING CONTROL : System Diagram

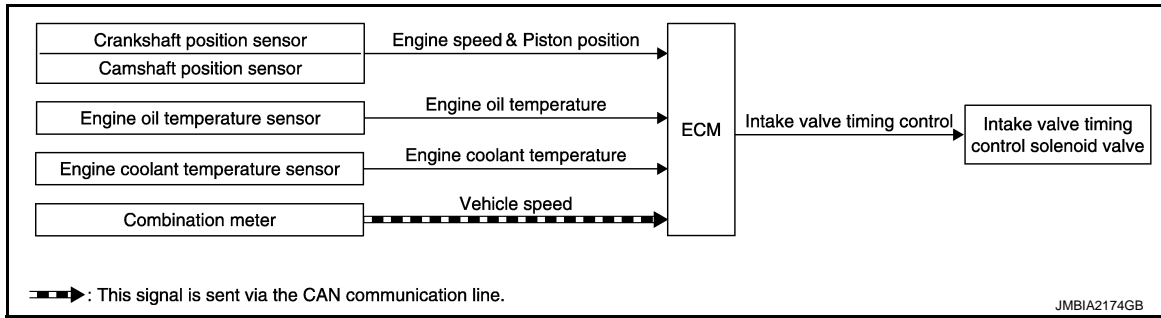

### INTAKE VALVE TIMING CONTROL : System Description

INFOID:000000007187201

#### INPUT/OUTPUT SIGNAL CHART

| Sensor                            | Input signal to ECM              | ECM function                | Actuator                                   |
|-----------------------------------|----------------------------------|-----------------------------|--|
| Crankshaft position sensor        | Engine speed and piston position | Intake valve timing control | Intake valve timing control solenoid valve |
| Camshaft position sensor          |                                  |                             |  |
| Engine oil temperature sensor     | Engine oil temperature           |                             |  |
| Engine coolant temperature sensor | Engine coolant temperature       |                             |  |
| Combination meter                 | Vehicle speed*                   |                             |  |

\*: This signal is sent to the ECM via the CAN communication line.

#### SYSTEM DESCRIPTION

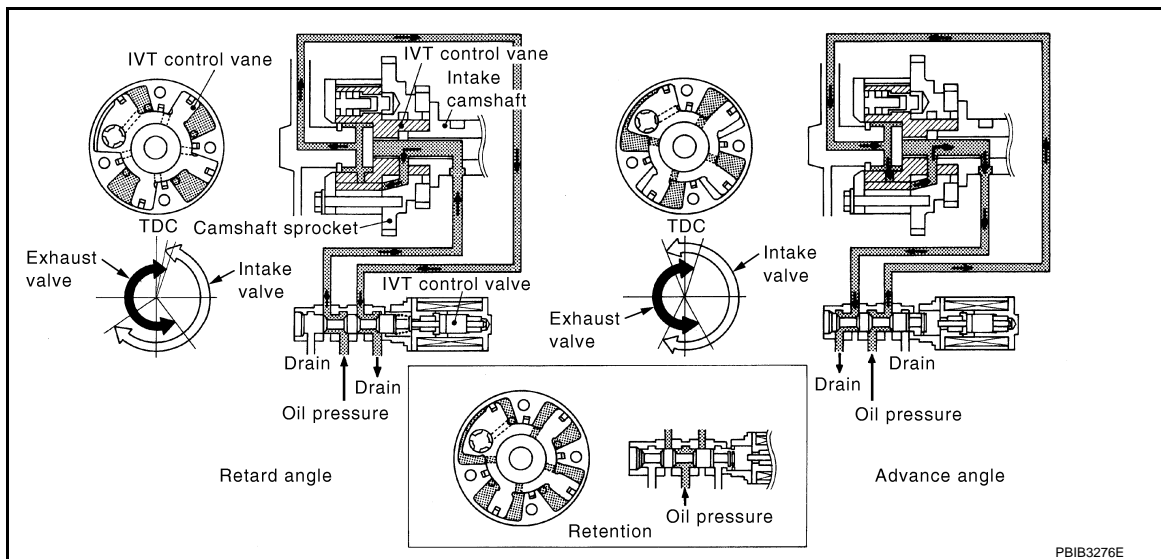

This mechanism hydraulically controls cam phases continuously with the fixed operating angle of the intake valve.

The ECM receives signals such as crankshaft position, camshaft position, engine speed, and engine coolant temperature. Then, the ECM sends ON/OFF pulse duty signals to the intake valve timing control solenoid valve depending on driving status. This makes it possible to control the shut/open timing of the intake valve to increase engine torque in low/mid speed range and output in high speed range.

#### EXHAUST VALVE TIMING CONTROL

# SYSTEM

< SYSTEM DESCRIPTION >

[VK56VD FOR USA AND CANADA]

## EXHAUST VALVE TIMING CONTROL : System Diagram

INFOID:000000007187202

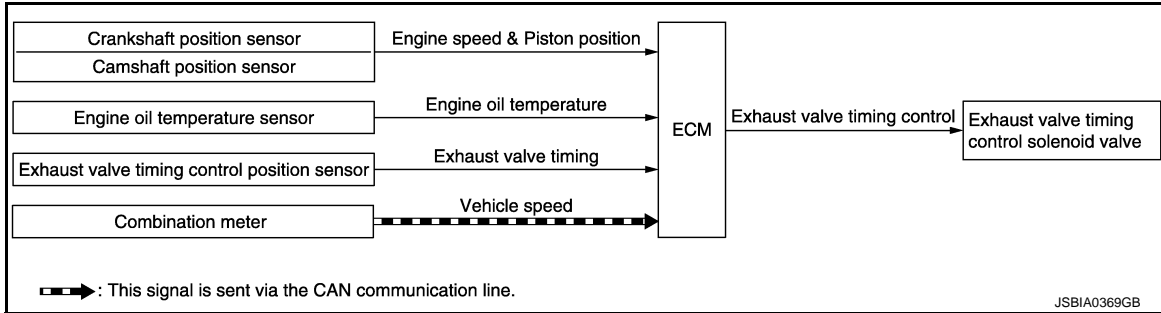

## EXHAUST VALVE TIMING CONTROL : System Description

INFOID:000000007187203

### INPUT/OUTPUT SIGNAL CHART

| Sensor                                       | Input signal to ECM              | ECM function                 | Actuator                                    |
|--|----------------------------------|------------------------------|---|
| Crankshaft position sensor                   | Engine speed and piston position | Exhaust valve timing control | Exhaust valve timing control solenoid valve |
| Camshaft position sensor                     |                                  |                              |   |
| Engine oil temperature sensor                | Engine oil temperature           |                              |   |
| Exhaust valve timing control position sensor | Exhaust valve timing signal      |                              |   |
| Combination meter                            | Vehicle speed*                   |                              |   |

\*: This signal is sent to the ECM via the CAN Communication line

### SYSTEM DESCRIPTION

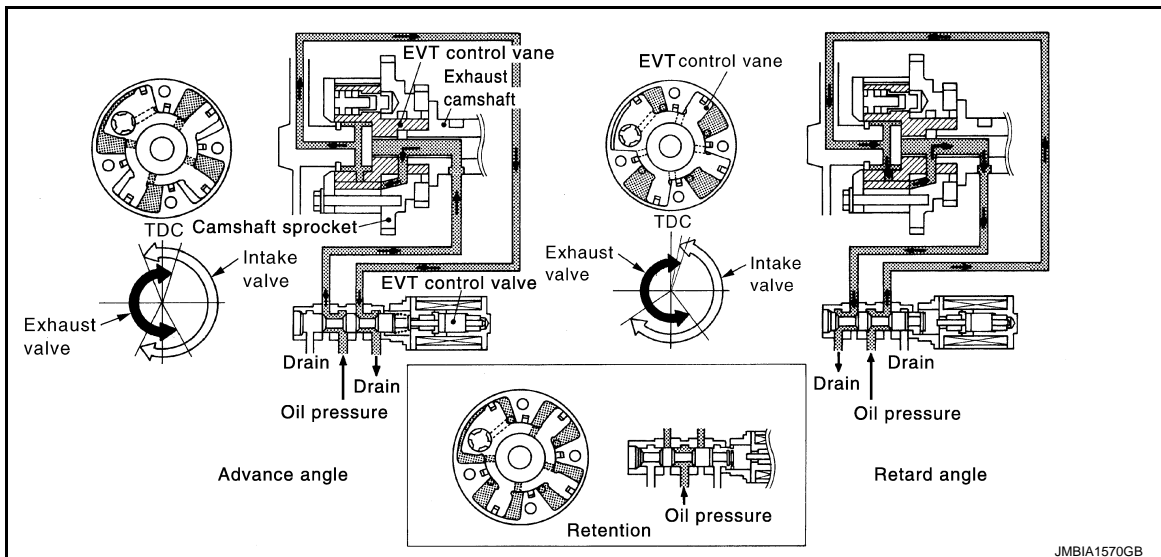

This mechanism hydraulically controls cam phases continuously with the fixed operating angle of the exhaust valve.

The ECM receives signals such as crankshaft position, camshaft position, engine speed, and engine oil temperature. Then, the ECM sends ON/OFF pulse duty signals to the exhaust valve timing control solenoid valve depending on driving status. This makes it possible to control the shut/open timing of the exhaust valve to increase engine torque and output in a range of high engine speed.

### VVEL SYSTEM

# SYSTEM

< SYSTEM DESCRIPTION >

[VK56VD FOR USA AND CANADA]

## VVEL SYSTEM : System Diagram

INFOID:000000007187204

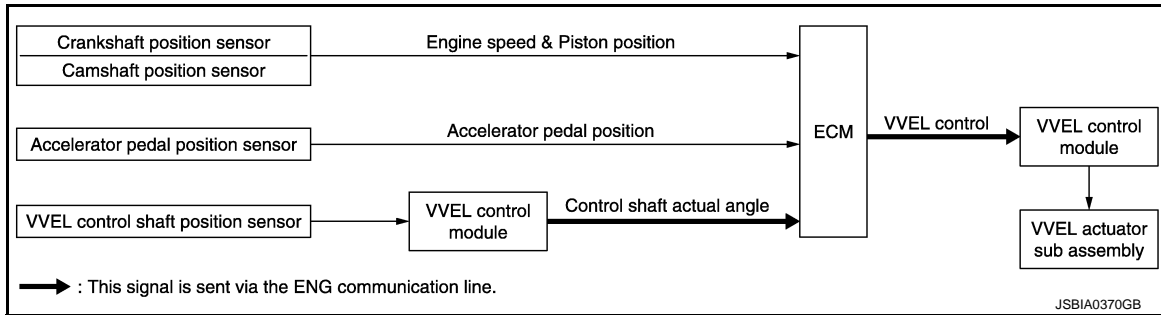

## VVEL SYSTEM : System Description

INFOID:000000007187205

### INPUT/OUTPUT SIGNAL CHART

| Sensor   | Input signal to ECM              | ECM function | Actuator   |
|--|----------------------------------|--------------|--|
| Camshaft position sensor<br>Crankshaft position sensor         | Engine speed and piston position | VVEL control | VVEL control module<br>↓<br>VVEL actuator sub assembly |
| Accelerator pedal position sensor                              | Accelerator pedal position       |              |  |
| VVEL control shaft position sensor<br>↓<br>VVEL control module | Control shaft actual angle       |              |  |

### SYSTEM DESCRIPTION

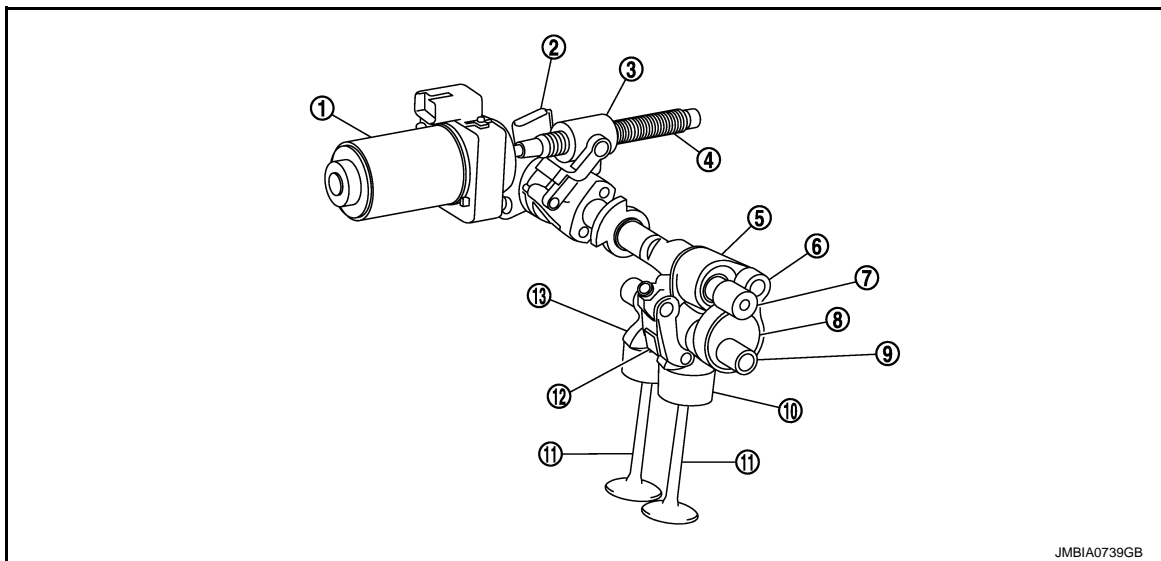

- |                        |                                       |                   |
|------------------------|---------------------------------------|-------------------|
| 1. VVEL actuator motor | 2. VVEL control shaft position sensor | 3. Ball screw nut |
| 4. Ball screw shaft    | 5. Rocker arm                         | 6. Link A         |
| 7. Control shaft       | 8. Eccentric cam                      | 9. Drive shaft    |
| 10. Valve lifter       | 11. Intake valve                      | 12. Link B        |
| 13. Output cam         |                                       |                   |

VVEL (Variable Valve Event & Lift) is a system that controls valve event and valve lift continuously. Rotational movement of the drive shaft equipped with eccentric cam is transmitted to output cam via the rocker arm and two kinds of links to depress the intake valve. ECM decides the target valve lift according to the driving condition and sends the command signal to the VVEL control module. The VVEL control module controls the rotation of the control shaft using the VVEL actuator motor and changes the movement of the output cam by shifting the link supporting point. As a result, valve lift changes continuously to improve engine output and response.

# SYSTEM

< SYSTEM DESCRIPTION >

[VK56VD FOR USA AND CANADA]

## EVAPORATIVE EMISSION SYSTEM

### EVAPORATIVE EMISSION SYSTEM : System Diagram

INFOID:000000007187206

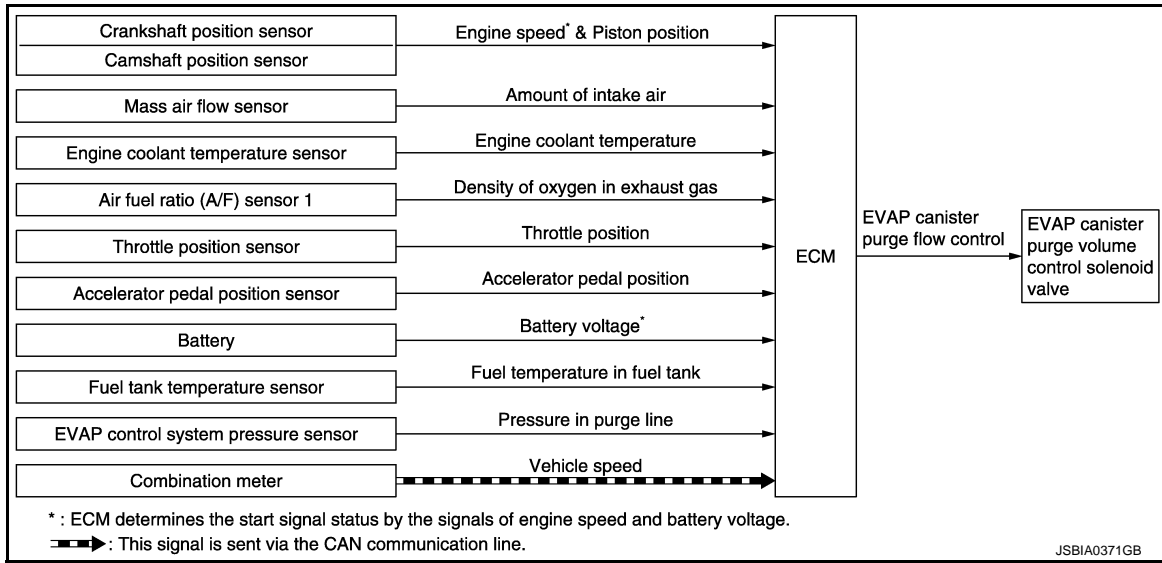

### EVAPORATIVE EMISSION SYSTEM : System Description

INFOID:000000007187207

#### INPUT/OUTPUT SIGNAL CHART

| Sensor   | Input signal to ECM   | ECM function                        | Actuator   |
|--|---|-------------------------------------|--|
| Crankshaft position sensor<br>Camshaft position sensor | Engine speed* <sup>1</sup>  | EVAP canister<br>purge flow control | EVAP canister purge volume<br>control solenoid valve |
| Mass air flow sensor                                   | Amount of intake air  |                                     |  |
| Engine coolant temperature sensor                      | Engine coolant temperature  |                                     |  |
| Battery  | Battery voltage* <sup>1</sup>                                       |                                     |  |
| Throttle position sensor                               | Throttle position   |                                     |  |
| Accelerator pedal position sensor                      | Accelerator pedal position  |                                     |  |
| Air fuel ratio (A/F) sensor 1                          | Density of oxygen in exhaust gas<br>(Mixture ratio feedback signal) |                                     |  |
| Fuel tank temperature sensor                           | Fuel temperature in fuel tank                                       |                                     |  |
| EVAP control system pressure sensor                    | Pressure in purge line  |                                     |  |
| Combination meter                                      | Vehicle speed* <sup>2</sup>   |                                     |  |

\*1: ECM determines the start signal status by the signals of engine speed and battery voltage.

\*2: This signal is sent to the ECM via the CAN communication line.

# SYSTEM

< SYSTEM DESCRIPTION >

[VK56VD FOR USA AND CANADA]

## SYSTEM DESCRIPTION

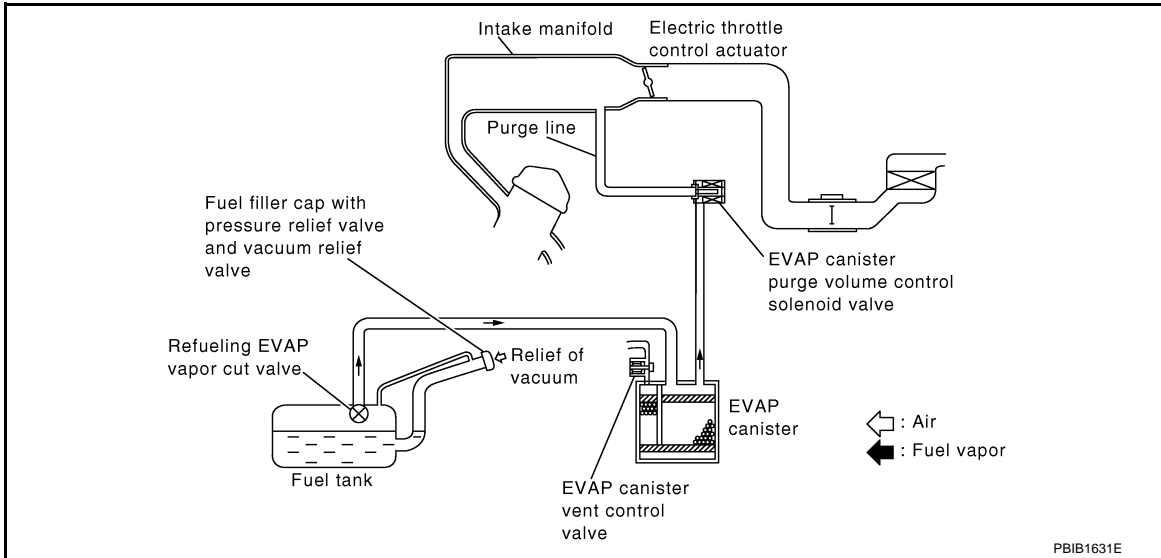

The evaporative emission system is used to reduce hydrocarbons emitted into the atmosphere from the fuel system. This reduction of hydrocarbons is accomplished by activated charcoals in the EVAP canister. The fuel vapor in the sealed fuel tank is led into the EVAP canister which contains activated carbon and the vapor is stored there when the engine is not operating or when refueling to the fuel tank. The vapor in the EVAP canister is purged by the air through the purge line to the intake manifold when the engine is operating. EVAP canister purge volume control solenoid valve is controlled by ECM. When the engine operates, the flow rate of vapor controlled by EVAP canister purge volume control solenoid valve is proportionally regulated as the air flow increases. EVAP canister purge volume control solenoid valve also shuts off the vapor purge line during decelerating and idling.

## AIR CONDITIONING CUT CONTROL

### AIR CONDITIONING CUT CONTROL : System Diagram

INFOID:000000007187208

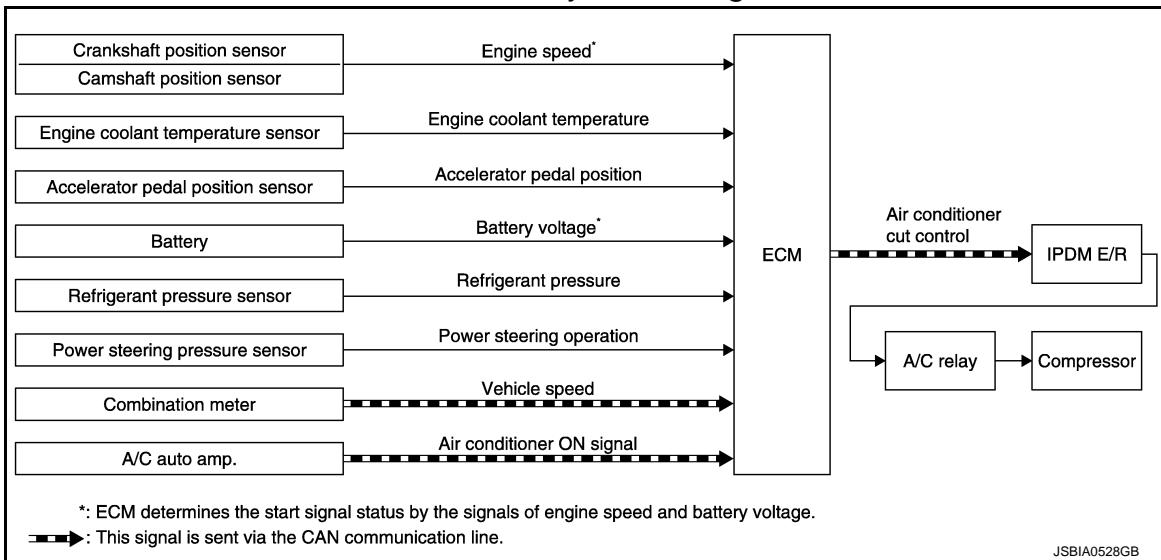

### AIR CONDITIONING CUT CONTROL : System Description

INFOID:000000007187209

#### INPUT/OUTPUT SIGNAL CHART

# SYSTEM

< SYSTEM DESCRIPTION >

[VK56VD FOR USA AND CANADA]

| Sensor   | Input signal to ECM                 | ECM function                   | Actuator                                      |
|--|-------------------------------------|--------------------------------|---|
| Crankshaft position sensor<br>Camshaft position sensor | Engine speed*1                      | Air conditioner<br>cut control | IPDM E/R<br>↓<br>A/C relay<br>↓<br>Compressor |
| Engine coolant temperature sensor                      | Engine coolant temperature          |                                |   |
| Accelerator pedal position sensor                      | Accelerator pedal position          |                                |   |
| Battery  | Battery voltage*1                   |                                |   |
| Refrigerant pressure sensor                            | Refrigerant pressure                |                                |   |
| Power steering pressure sensor                         | Power steering operation            |                                |   |
| A/C auto amp.  | A/C ON signal*2                     |                                |   |
|  | A/C evaporator temperature*2        |                                |   |
|  | Target A/C evaporator temperature*2 |                                |   |
|  | Blower ON signal                    |                                |   |
| Combination meter                                      | Vehicle speed*2                     |                                |   |

\*1: The ECM determines the start signal status by the signals of engine speed and battery voltage.

\*2: This signal is sent to ECM via the CAN communication line.

## SYSTEM DESCRIPTION

This system improves engine operation when the air conditioner is used.

Under the following conditions, the air conditioner is turned off.

- When the accelerator pedal is fully depressed.
- When cranking the engine.
- At high engine speeds.
- When the engine coolant temperature becomes excessively high.
- When operating power steering during low engine speed or low vehicle speed.
- When engine speed is excessively low.
- When refrigerant pressure is excessively low or high.

## ALTERNATOR POWER GENERATION VOLTAGE VARIABLE CONTROL SYSTEM

### ALTERNATOR POWER GENERATION VOLTAGE VARIABLE CONTROL SYSTEM : System Description

INFOID:000000007768661

The alternator power generation voltage variable control system controls the amount of power generation, according to a battery loaded condition. ECM judges a battery condition, according to a signal received from the battery current sensor which detects a charge/discharge current. ECM then transmits a signal to IPDM E/R to command power generation via CAN communication. IPDM E/R transmits a power generation control signal to the alternator so that the system can control the amount of power generation. The voltage of power generation is lowered during battery low-load conditions and boosted under heavy load conditions. In this way, the system reduces the engine load through the adequate power generation control.

For details, refer to [CHG-8. "POWER GENERATION VOLTAGE VARIABLE CONTROL SYSTEM : System Diagram"](#).

### AUTOMATIC SPEED CONTROL DEVICE (ASCD)



# SYSTEM

< SYSTEM DESCRIPTION >

[VK56VD FOR USA AND CANADA]

## AUTOMATIC SPEED CONTROL DEVICE (ASCD) : System Diagram

INFOID:000000007187210

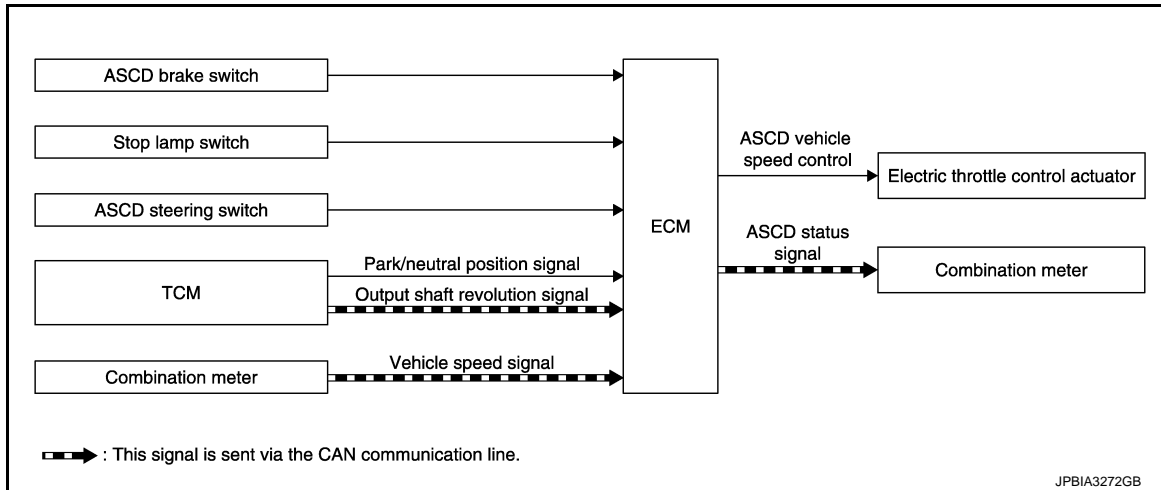

## AUTOMATIC SPEED CONTROL DEVICE (ASCD) : System Description

INFOID:000000007187211

### INPUT/OUTPUT SIGNAL CHART

| Sensor               | Input signal to ECM             | ECM function               | Actuator                           |
|----------------------|---------------------------------|----------------------------|------------------------------------|
| ASCD brake switch    | Brake pedal operation           | ASCD vehicle speed control | Electric throttle control actuator |
| Stop lamp switch     | Brake pedal operation           |                            |                                    |
| ASCD steering switch | ASCD steering switch operation  |                            |                                    |
| TCM                  | Park/neutral position signal    | ASCD status signal         | Combination meter                  |
|                      | Output shaft revolution signal* |                            |                                    |
| Combination meter    | Vehicle speed*                  |                            |                                    |

\*: This signal is sent to the ECM via the CAN communication line

### BASIC ASCD SYSTEM

- Automatic Speed Control Device (ASCD) allows a driver to keep vehicle at predetermined constant speed without depressing accelerator pedal. Driver can be set the vehicle speed in the set speed range.
- ECM controls throttle angle of electric throttle control actuator to regulate engine speed.
- Operation status of ASCD is indicated in combination meter.
- If any malfunction occurs in the ASCD system, it automatically deactivates the ASCD control.

Refer to [EC-1030. "AUTOMATIC SPEED CONTROL DEVICE \(ASCD\) : Switch Name and Function"](#) for ASCD operating instructions.

### CAUTION:

**Always drive vehicle in a safe manner according to traffic conditions and obey all traffic laws.**

### CAN COMMUNICATION

#### CAN COMMUNICATION : System Description

INFOID:000000007187212

CAN (Controller Area Network) is a serial communication line for real time application. It is an on-vehicle multiplex communication line with high data communication speed and excellent error detection ability. Many electronic control units are equipped onto a vehicle, and each control unit shares information and links with other control units during operation (not independent). In CAN communication, control units are connected with 2 communication lines (CAN H line, CAN L line) allowing a high rate of information transmission with less wiring. Each control unit transmits/receives data but selectively reads required data only.

Refer to [LAN-35. "CAN COMMUNICATION SYSTEM : CAN Communication Signal Chart"](#), about CAN communication for detail.

### FUEL FILLER CAP WARNING SYSTEM

# SYSTEM

< SYSTEM DESCRIPTION >

[VK56VD FOR USA AND CANADA]

## FUEL FILLER CAP WARNING SYSTEM : System Diagram

INFOID:000000007195226

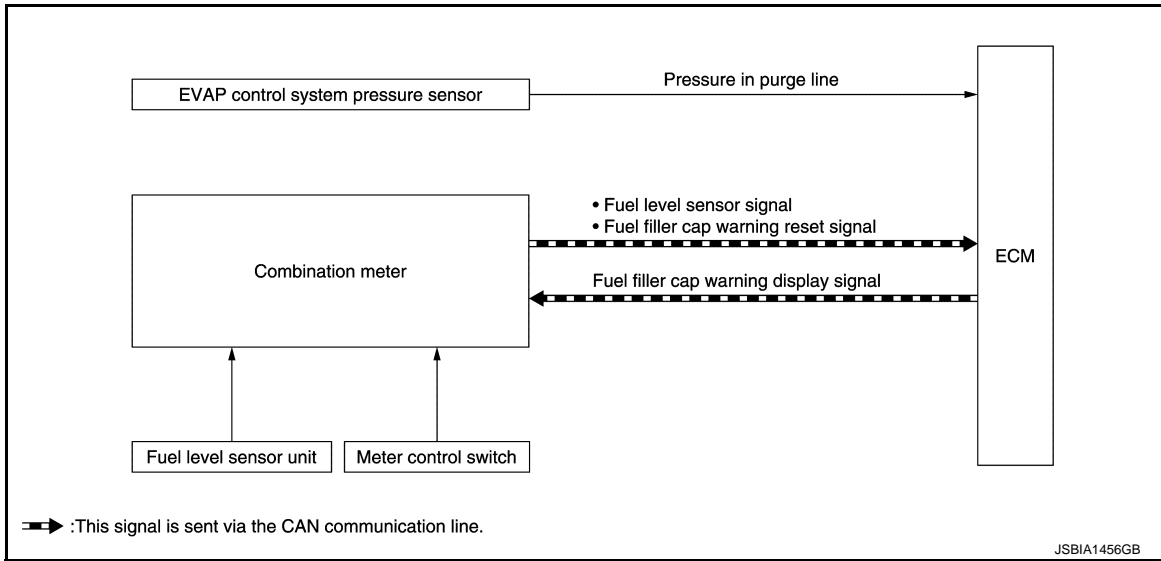

## FUEL FILLER CAP WARNING SYSTEM : System Description

INFOID:000000007195227

### INPUT/OUTPUT SIGNAL CHART

#### Input

| Unit/Sensor                         | Input signal to ECM                   | ECM function                    |
|-------------------------------------|---------------------------------------|---------------------------------|
| EVAP control system pressure sensor | Pressure in purge line                | Fuel filler cap warning control |
| Combination meter                   | Fuel level sensor signal*             |                                 |
|                                     | Fuel filler cap warning reset signal* |                                 |

\*: This signal is sent to the ECM via the CAN communication line.

#### Output

| Unit | Output signal                           | Actuator          |
|------|---|-------------------|
| ECM  | Fuel filler cap warning display signal* | Combination meter |

\*: This signal is sent to the combination meter via the CAN communication line.

### SYSTEM DESCRIPTION

The fuel filler cap warning system alerts the driver to the prevention of the fuel filler being left uncapped and malfunction occurrences after refueling, by turning ON the fuel filler cap warning display on the combination meter.

ECM judges a refueled state, based on a fuel level signal transmitted from the combination meter.

When a very small leak is detected through the EVAP leak diagnosis performed after judging the refueled state, ECM transmits a fuel filler cap warning display signal (request for display ON) to the combination meter via CAN communication.

When receiving the signal, the combination meter turns ON the fuel filler cap warning display.

#### **CAUTION:**

**Check fuel filler cap installation condition when the fuel filler cap warning display turns ON.**

#### Reset Operation

The fuel filler cap warning lamp turns OFF, according to any condition listed below:

- Reset operation is performed by operating the meter control switch on the combination meter. Refer to [MWI-19. "INFORMATION DISPLAY : System Description"](#).
- When the reset operation is performed, the combination meter transmits a fuel filler cap warning reset signal to ECM via CAN communication. ECM transmits a fuel filler cap warning display signal (request for display OFF) to the combination meter via CAN communication. When receiving the signal, the combination meter turns OFF the fuel filler cap warning display.
- EVAP leak diagnosis result is normal.
- Fuel refilled.
- DTC erased by using CONSULT.

**NOTE:**

MIL turns ON if a malfunction is detected in leak diagnosis results again at the trip after the fuel filler cap warning display turns ON/OFF.

## Infiniti Drive Mode Selector

### Infiniti Drive Mode Selector : System Description

INFOID:000000007187213

#### System Diagram

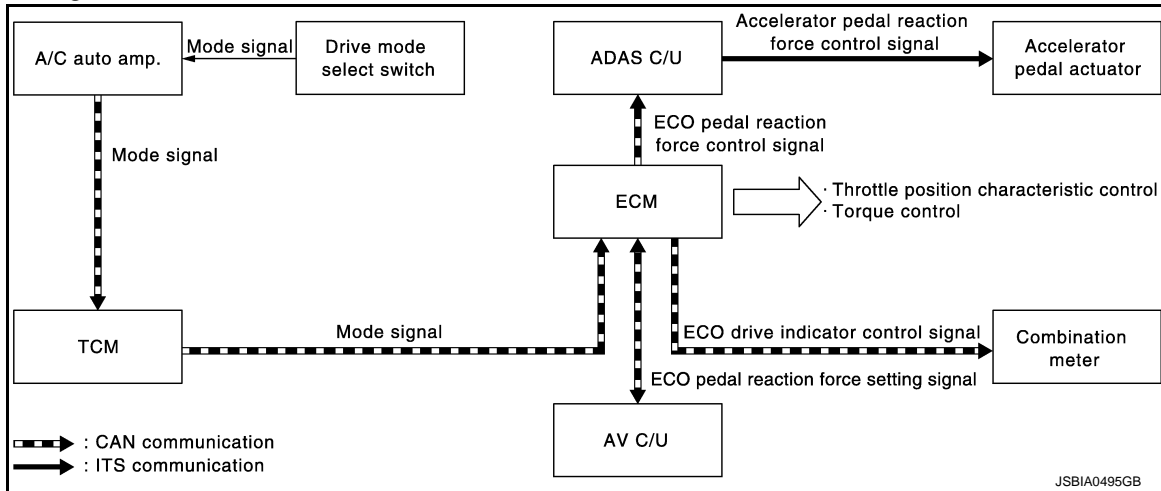

**NOTE:**

- This section provides descriptions only about the control by ECM.  
For overall control, refer to [DMS-5, "Infiniti Drive Mode Selector : System Description"](#).
- ECO pedal control is only for vehicles with intelligent pedal (distance control assist).

#### Infiniti drive mode selector

- A/C auto amp. receives an operation state signal of the drive mode select switch and transmits a mode signal (see below) to TCM via CAN communication.
  - STANDARD: ON/OFF
  - SPORT: ON/OFF
  - ECO: ON/OFF
  - SNOW: ON/OFF
- TCM transmits a mode state signal to ECM via CAN communication, based on a ECO mode signal received from the A/C auto amp.
- ECM controls throttle angle characteristics and torque appropriate to each mode, based on a ECO mode signal received from TCM via CAN communication.
- The combination meter turns ON or blinks (with ECO pedal) the ECO drive indicator when in ECO mode, based on a ECO drive indicator control signal received from ECM via CAN communication.

#### ECO pedal control

- The AV control unit transmits an ECO pedal reaction force setting signal (Standard/Soft/OFF) to ECM via CAN communication.

**NOTE:**

- An ECO pedal reaction force setting signal which determines reaction force of the accelerator pedal can be selected on the settings screen of the Multi AV system.
- ECM transmits an ECO pedal reaction force control signal to the ADAS control unit via CAN communication, based on a ECO mode signal received from TCM via CAN communication and an ECO pedal reaction force setting signal received from the AV control unit via CAN communication.
- ECM sends back an ECO pedal reaction force setting signal received from the AV control unit to the AV control unit for confirmation.
- The ADAS control unit controls pedal reaction force of the accelerator pedal actuator via ITS communication, based on an ECO pedal reaction force control signal received from the ADAS control unit.

#### Control

- With the drive mode selector, a drive mode select switch installed at the top of the center console switches a vehicle drive mode, changes throttle angle characteristics, and controls torque and ECO pedal.
- Vehicle characteristics are controlled in the following modes, on the basis of STANDARD mode ("●" position of the drive mode select switch).

# SYSTEM

## < SYSTEM DESCRIPTION >

[VK56VD FOR USA AND CANADA]

- SPORT: Changing throttle angle characteristics allows to use a high engine performance range and increases driving performance.
- ECO: Changing throttle angle characteristics and controlling torque, ECO drive indicator, and ECO pedal enhance fuel economy in actual traffic.
- SNOW: Changing throttle angle characteristics enhances driving performance on roads with a low coefficient of friction.

| Control item | Vehicle drive mode |     |      | Description   |
|--------------|--------------------|-----|------|---|
|              | SPORT              | ECO | SNOW |   |
| Engine       | ×                  | ×   | ×    | Changes throttle angle and controls torque*1 and the ECO drive indicator*1. |
| ECO pedal*2  |                    | ×   |      | Controls ECO pedal (Accelerator pedal reaction force control).              |

\*1: Torque control and the ECO drive indicator is available only when in ECO mode.

\*2: ECO pedal control is only for vehicles with an intelligent pedal (distance control assist).

### ECO drive indicator control

- ECO drive indicator turns ON or blinks (with ECO pedal) when in ECO mode, according to the operation of the accelerator pedal.
- For vehicles with ECO pedal, the blinking timing of the ECO drive indicator (green) synchronizes to the generation timing of ECO pedal reaction force.

| ECO drive indicator                      | Driving condition   |
|--|---|
| ON (Green)                               | Within the ECO drive range.   |
| Blink (Green) (if so equipped ECO pedal) | Likely over the ECO drive range.  |
| ON (Orange)                              | Over the ECO drive range.   |
| OFF                                      | Low-speed range [approx. 3 MPH (4.8 km/h) or less] and high-speed range [approx. 90 MPH (144 km/h) or more] |

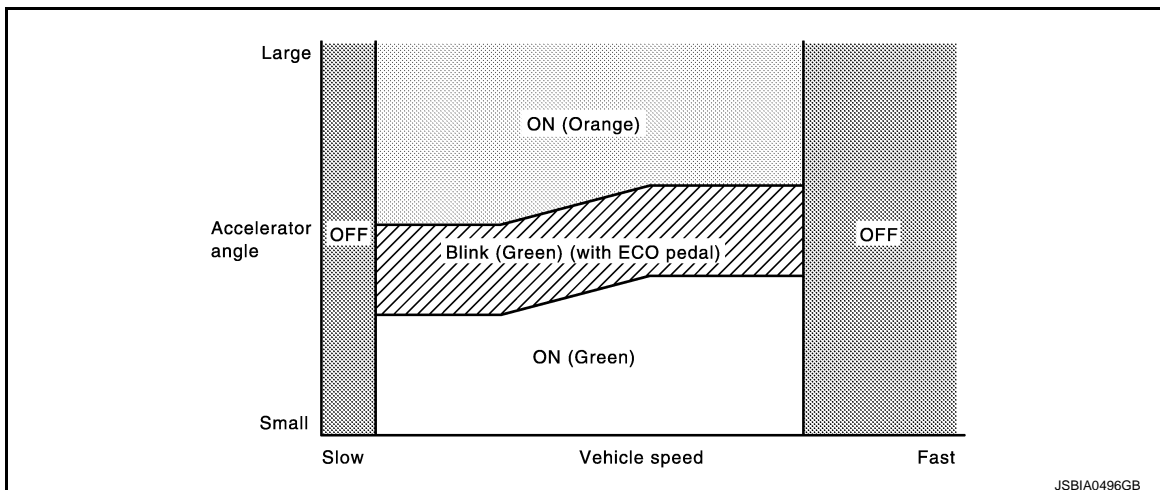

### NOTE:

ECO drive indicator turns OFF under the following conditions.

- Intelligent cruise control in operation.
- Selector lever is in R range.

### ECO pedal control

- Increasing reaction force of the accelerator pedal supports ECO driving in accordance with the accelerator pedal operation when in ECO mode.
- The level of reaction force to the accelerator pedal can be changed among Standard/Soft/OFF on the navigation screen. ECO pedal reaction force can be turned OFF even when in ECO mode.
- The generation timing of ECO pedal reaction force synchronizes to the blinking timing of the ECO drive indicator (Green).

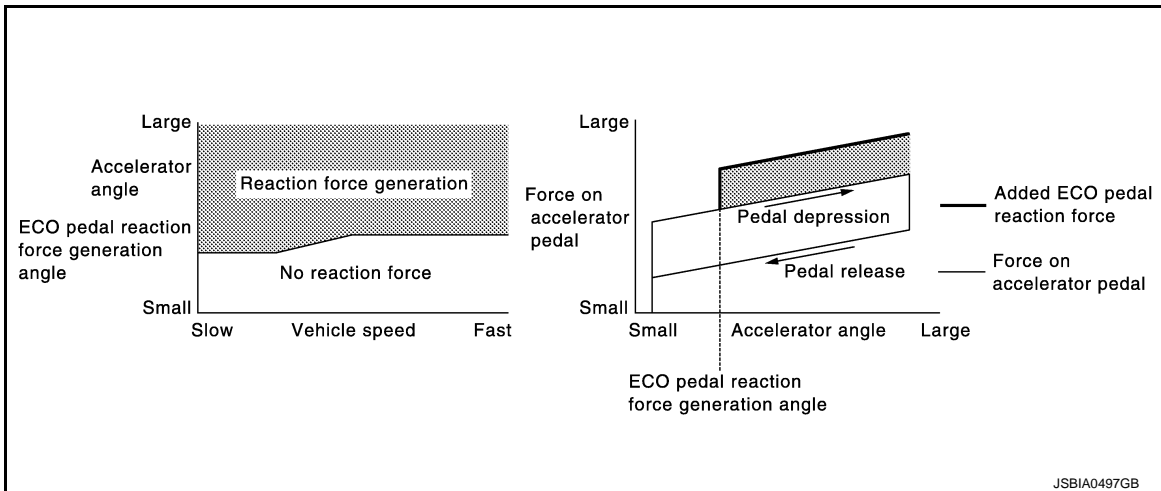

**NOTE:**

- When switching from ECO mode to the other mode by operating the drive mode select switch, ECO pedal reaction force is generated in common with ECO mode until the accelerator pedal is released.
- ECO pedal reaction force is not generated under the following conditions.
  - Intelligent cruise control is in operation.
  - Accelerator pedal is depressed quickly.
  - Selector lever is in N or R range.

A  
EC  
C  
D  
E  
F  
G  
H  
I  
J  
K  
L  
M  
N  
O  
P

# OPERATION

< SYSTEM DESCRIPTION >

[VK56VD FOR USA AND CANADA]

## OPERATION

### AUTOMATIC SPEED CONTROL DEVICE (ASCD)

### AUTOMATIC SPEED CONTROL DEVICE (ASCD) : Switch Name and Function

INFOID:000000007187214

#### SWITCHES AND INDICATORS

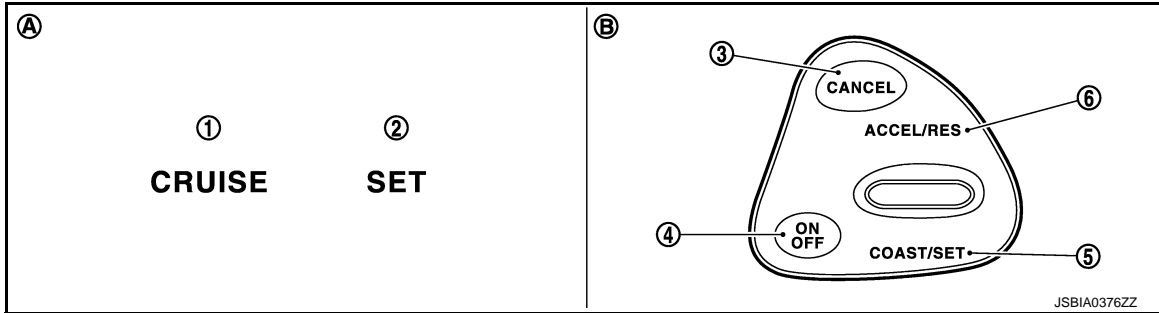

- |   |                     |                             |
|---|---------------------|-----------------------------|
| 1. CRUISE indicator                               | 2. SET indicator    | 3. CANCEL switch            |
| 4. ASCD MAIN switch                               | 5. SET/COAST switch | 6. RESUME/ACCELERATE switch |
| A. On the combination meter (Information display) |                     |                             |
| B. On the steering wheel                          |                     |                             |

#### SET SPEED RANGE

ASCD system can be set the following vehicle speed.

|                         |                         |
|-------------------------|-------------------------|
| Minimum speed (Approx.) | Maximum speed (Approx.) |
| 40 km/h (25 MPH)        | 143 km/h (88 MPH)       |

#### SWITCH OPERATION

| Item              | Function   |
|-------------------|--|
| CANCEL switch     | Cancels the cruise control driving.  |
| RESUME/ACCELERATE | <ul style="list-style-type: none"> <li>Resumes the set speed.</li> <li>Increases speed incrementally during cruise control driving.</li> </ul>     |
| SET/COAST         | <ul style="list-style-type: none"> <li>Sets desired cruise speed.</li> <li>Decreases speed incrementally during cruise control driving.</li> </ul> |
| ASCD MAIN switch  | Master switch to activate the ASCD system.   |

#### CANCEL OPERATION

When any of following conditions exist, cruise operation will be canceled.

- CANCEL switch is pressed
- ASCD MAIN switch pressed (Set speed is cleared)
- More than 2 switches at ASCD steering switch are pressed at the same time (Set speed will be cleared)
- Brake pedal is depressed
- Selector lever position is changed to N, P or R
- Vehicle speed decreased to 13 km/h (8 MPH) lower than the set speed
- TCS system is operated

When the ECM detects any of the following conditions, the ECM will cancel the cruise operation and inform the driver by blinking indicator.

- Engine coolant temperature is slightly higher than the normal operating temperature, CRUISE indicator may blink slowly.  
When the engine coolant temperature decreases to the normal operating temperature, CRUISE indicator will stop blinking and the cruise operation will be able to work by pressing SET/COAST switch or RESUME/ACCELERATE switch.
- Malfunction for some self-diagnoses regarding ASCD control: SET indicator will blink quickly.

**OPERATION**

**[VK56VD FOR USA AND CANADA]**

**< SYSTEM DESCRIPTION >**

If MAIN switch is turned to OFF during ASCD is activated, all of ASCD operations will be canceled and vehicle speed memory will be erased.

A

**EC**

C

D

E

F

G

H

I

J

K

L

M

N

O

P

## HANDLING PRECAUTION

### Infiniti Drive Mode Selector

INFOID:000000007187215

#### ECO DRIVE INDICATOR LAMP CONTROL

- ECO drive indicator turns OFF under the following conditions.
  - While driving at low speeds [3 MPH (4.8 km/h) or less] or high speeds [90 MPH (144 km/h) or more].
  - Intelligent cruise control is in operation.
  - Selector lever is in R range.

#### ECO PEDAL CONTROL

- When switching from ECO mode to the other mode by operating the drive mode select switch, ECO pedal reaction force is generated in common with ECO mode until the accelerator pedal is released.
- ECO pedal reaction force is not generated under the following conditions.
  - Intelligent cruise control is in operation.
  - Accelerator pedal is depressed quickly.
  - Selector lever is in N or R range.
  - ECO pedal reaction force setting is OFF.

**NOTE:**

ECO pedal control is only for vehicles with an intelligent pedal (distance control assist).

#### ENGINE OUTPUT CHARACTERISTICS AFTER SWITCHING MODE

- Engine output characteristics after switching mode by operating the drive mode select switch are as follows.
  - After switching mode to a mode that engine output increase, engine output characteristics are changed by releasing the accelerator pedal.
  - After switching mode to a mode that engine output decreases, engine output characteristics are changed immediately.
- When an accelerator angle is constant, engine output characteristics are as follows.
  - SPORT > STANDARD > ECO > SNOW

Output characteristics of each mode

| Control mode | Engine output                           |
|--------------|---|
| SPORT        | Increase                                |
| STANDARD     | Normal                                  |
| ECO          | Decrease                                |
| SNOW         | Decrease (More reduction than ECO mode) |



# ON BOARD DIAGNOSTIC (OBD) SYSTEM

< SYSTEM DESCRIPTION >

[VK56VD FOR USA AND CANADA]

## ON BOARD DIAGNOSTIC (OBD) SYSTEM

### Diagnosis Description

INFOID:000000007187216

This system is an on board diagnostic system that records exhaust emission-related diagnostic information and detects a sensors/actuator-related malfunction. A malfunction is indicated by the malfunction indicator lamp (MIL) and stored in control module memory as a DTC. The diagnostic information can be obtained with the diagnostic tool (GST: Generic Scan Tool).

A  
EC  
C  
D  
E  
F  
G  
H  
I  
J  
K  
L  
M  
N  
O  
P

### GST (Generic Scan Tool)

INFOID:000000007187217

When GST is connected with a data link connector equipped on the vehicle side, it will communicate with the control module equipped in the vehicle and then enable various kinds of diagnostic tests. Refer to [EC-1033](#), "[Diagnosis Description](#)".

# DIAGNOSIS SYSTEM (ECM)

< SYSTEM DESCRIPTION >

[VK56VD FOR USA AND CANADA]

## DIAGNOSIS SYSTEM (ECM)

### DIAGNOSIS DESCRIPTION

#### DIAGNOSIS DESCRIPTION : 1st Trip Detection Logic and Two Trip Detection Logic

INFOID:000000007229406

When a malfunction is detected for the first time, 1st trip DTC and 1st trip Freeze Frame data are stored in the ECM memory. The MIL will not illuminate at this stage. <1st trip>

If the same malfunction is detected again during the next drive, the DTC and Freeze Frame data are stored in the ECM memory, and the MIL illuminates. The MIL illuminates at the same time when the DTC is stored. <2nd trip> The "trip" in the "Two Trip Detection Logic" means a driving mode in which self-diagnosis is performed during vehicle operation. Specific on board diagnostic items will cause the ECM to illuminate or blink the MIL, and store DTC and Freeze Frame data, even in the 1st trip, as shown below.

×: Applicable —: Not applicable

| Items   | MIL      |             |          |             | DTC                 |                     | 1st trip DTC        |                     |
|---|----------|-------------|----------|-------------|---------------------|---------------------|---------------------|---------------------|
|   | 1st trip |             | 2nd trip |             | 1st trip displaying | 2nd trip displaying | 1st trip displaying | 2nd trip displaying |
|   | Blinking | Illuminated | Blinking | Illuminated |                     |                     |                     |                     |
| Misfire (Possible three way catalyst damage) — DTC: P0300 – P0308 is being detected | ×        | —           | —        | —           | —                   | —                   | ×                   | —                   |
| Misfire (Possible three way catalyst damage) — DTC: P0300 – P0308 is being detected | —        | —           | ×        | —           | —                   | ×                   | —                   | —                   |
| One trip detection diagnoses (Refer to <a href="#">EC-1083, "DTC Index"</a> .)      | —        | ×           | —        | —           | ×                   | —                   | —                   | —                   |
| Except above  | —        | —           | —        | ×           | —                   | ×                   | ×                   | —                   |

#### DIAGNOSIS DESCRIPTION : DTC and Freeze Frame Data

INFOID:000000007229407

##### DTC AND 1ST TRIP DTC

The 1st trip DTC (whose number is the same as the DTC number) is displayed for the latest self-diagnostic result obtained. If the ECM memory was cleared previously, and the 1st trip DTC did not recur, the 1st trip DTC will not be displayed.

If a malfunction is detected during the 1st trip, the 1st trip DTC is saved in the ECM memory. The MIL will not light up (two trip detection logic). If the same malfunction is not detected in the 2nd trip (meeting the required driving pattern), the 1st trip DTC is cleared from the ECM memory. If the same malfunction is detected in the 2nd trip, both the 1st trip DTC and DTC are saved in the ECM memory and the MIL lights up. In other words, the DTC is stored in the ECM memory and the MIL lights up when the same malfunction occurs in two consecutive trips. If a 1st trip DTC is stored and a non-diagnostic operation is performed between the 1st and 2nd trips, only the 1st trip DTC will continue to be stored. For malfunctions that blink or light up the MIL during the 1st trip, the DTC and 1st trip DTC are stored in the ECM memory.

For malfunctions in which 1st trip DTCs are displayed, refer to [EC-1083, "DTC Index"](#). These items are required by legal regulations to continuously monitor the system/component. In addition, the items monitored non-continuously are also displayed on CONSULT.

1st trip DTC is specified in Service \$07 of SAE J1979/ISO 15031-5. 1st trip DTC detection occurs without illuminating the MIL and therefore does not warn the driver of a malfunction.

When a 1st trip DTC is detected, check, print out or write down and erase (1st trip) DTC and Freeze Frame data as specified in Work Flow procedure Step 2, refer to [EC-1108, "Work Flow"](#). Then perform DTC Confirmation Procedure or Component Function Check to try to duplicate the malfunction. If the malfunction is duplicated, the item requires repair.

##### FREEZE FRAME DATA AND 1ST TRIP FREEZE FRAME DATA

The ECM records the driving conditions such as fuel system status, calculated load value, engine coolant temperature, short term fuel trim, long term fuel trim, engine speed, vehicle speed, absolute throttle position, base fuel schedule and intake air temperature at the moment a malfunction is detected.

Data which are stored in the ECM memory, along with the 1st trip DTC, are called 1st trip freeze frame data. The data, stored together with the DTC data, are called freeze frame data and displayed on CONSULT or GST. The 1st trip freeze frame data can only be displayed on the CONSULT screen.

# DIAGNOSIS SYSTEM (ECM)

[VK56VD FOR USA AND CANADA]

## < SYSTEM DESCRIPTION >

Only one set of freeze frame data (either 1st trip freeze frame data or freeze frame data) can be stored in the ECM. 1st trip freeze frame data is stored in the ECM memory along with the 1st trip DTC. There is no priority for 1st trip freeze frame data and it is updated each time a different 1st trip DTC is detected. However, once freeze frame data (2nd trip detection/MIL on) is stored in the ECM memory, 1st trip freeze frame data is no longer stored. Remember, only one set of freeze frame data can be stored in the ECM. The ECM has the following priorities to update the data.

| Priority | Items                      |  |
|----------|----------------------------|--|
| 1        | Freeze frame data          | Misfire — DTC: P0300 – P0308<br>Fuel Injection System Function — DTC: P0171, P0172, P0174, P0175 |
| 2        |                            | Except the above items   |
| 3        | 1st trip freeze frame data |  |

For example, the EGR malfunction (Priority: 2) was detected and the freeze frame data was saved in the 2nd trip. After that when the misfire (Priority: 1) is detected in another trip, the freeze frame data will be updated from the EGR malfunction to the misfire. The 1st trip freeze frame data is updated each time a different malfunction is detected. There is no priority for 1st trip freeze frame data. However, once freeze frame data is stored in the ECM memory, 1st trip freeze data is no longer stored (because only one freeze frame data or 1st trip freeze frame data can be stored in the ECM). If freeze frame data is stored in the ECM memory and freeze frame data with the same priority occurs later, the first (original) freeze frame data remains unchanged in the ECM memory.

Both 1st trip freeze frame data and freeze frame data (along with the DTCs) are cleared when the ECM memory is erased.

## DIAGNOSIS DESCRIPTION : Counter System

INFOID:000000007229408

### RELATIONSHIP BETWEEN MIL, 1ST TRIP DTC, DTC, AND DETECTABLE ITEMS

- When a malfunction is detected for the first time, the 1st trip DTC and the 1st trip freeze frame data are stored in the ECM memory.
- When the same malfunction is detected in two consecutive trips, the DTC and the freeze frame data are stored in the ECM memory, and the MIL will come on.
- The MIL will turn OFF after the vehicle is driven 3 times (driving pattern B) with no malfunction. The drive is counted only when the recorded driving pattern is met (as stored in the ECM). If another malfunction occurs while counting, the counter will reset.
- The DTC and the freeze frame data will be stored until the vehicle is driven 40 times (driving pattern A) without the same malfunction recurring (except for Misfire and Fuel Injection System). For Misfire and Fuel Injection System, the DTC and freeze frame data will be stored until the vehicle is driven 80 times (driving pattern C) without the same malfunction recurring. The “TIME” in “SELF-DIAGNOSTIC RESULTS” mode of CONSULT will count the number of times the vehicle is driven.
- The 1st trip DTC is not displayed when the self-diagnosis results in OK for the 2nd trip.

### COUNTER SYSTEM CHART

| Items                               | Fuel Injection System | Misfire           | Other          |
|-------------------------------------|-----------------------|-------------------|----------------|
| MIL (turns OFF)                     | 3 (pattern B)         | 3 (pattern B)     | 3 (pattern B)  |
| DTC, Freeze Frame Data (no display) | 80 (pattern C)        | 80 (pattern C)    | 40 (pattern A) |
| 1st Trip DTC (clear)                | 1 (pattern C), *1     | 1 (pattern C), *1 | 1 (pattern B)  |
| 1st Trip Freeze Frame Data (clear)  | *1, *2                | *1, *2            | 1 (pattern B)  |

For details about patterns B and C under “Fuel Injection System” and “Misfire”, see “EXPLANATION FOR DRIVING PATTERNS FOR “MISFIRE <EXHAUST QUALITY DETERIORATION>”, “FUEL INJECTION SYSTEM”.

For details about patterns A and B under Other, see “EXPLANATION FOR DRIVING PATTERNS FOR “MISFIRE <EXHAUST QUALITY DETERIORATION>”, “FUEL INJECTION SYSTEM”.

- \*1: Clear timing is at the moment OK is detected.
- \*2: Clear timing is when the same malfunction is detected in the 2nd trip.

Relationship Between MIL, DTC, 1st Trip DTC and Driving Patterns for “Misfire <Exhaust Quality Deterioration>”, “Fuel Injection System”

# DIAGNOSIS SYSTEM (ECM)

< SYSTEM DESCRIPTION >

[VK56VD FOR USA AND CANADA]

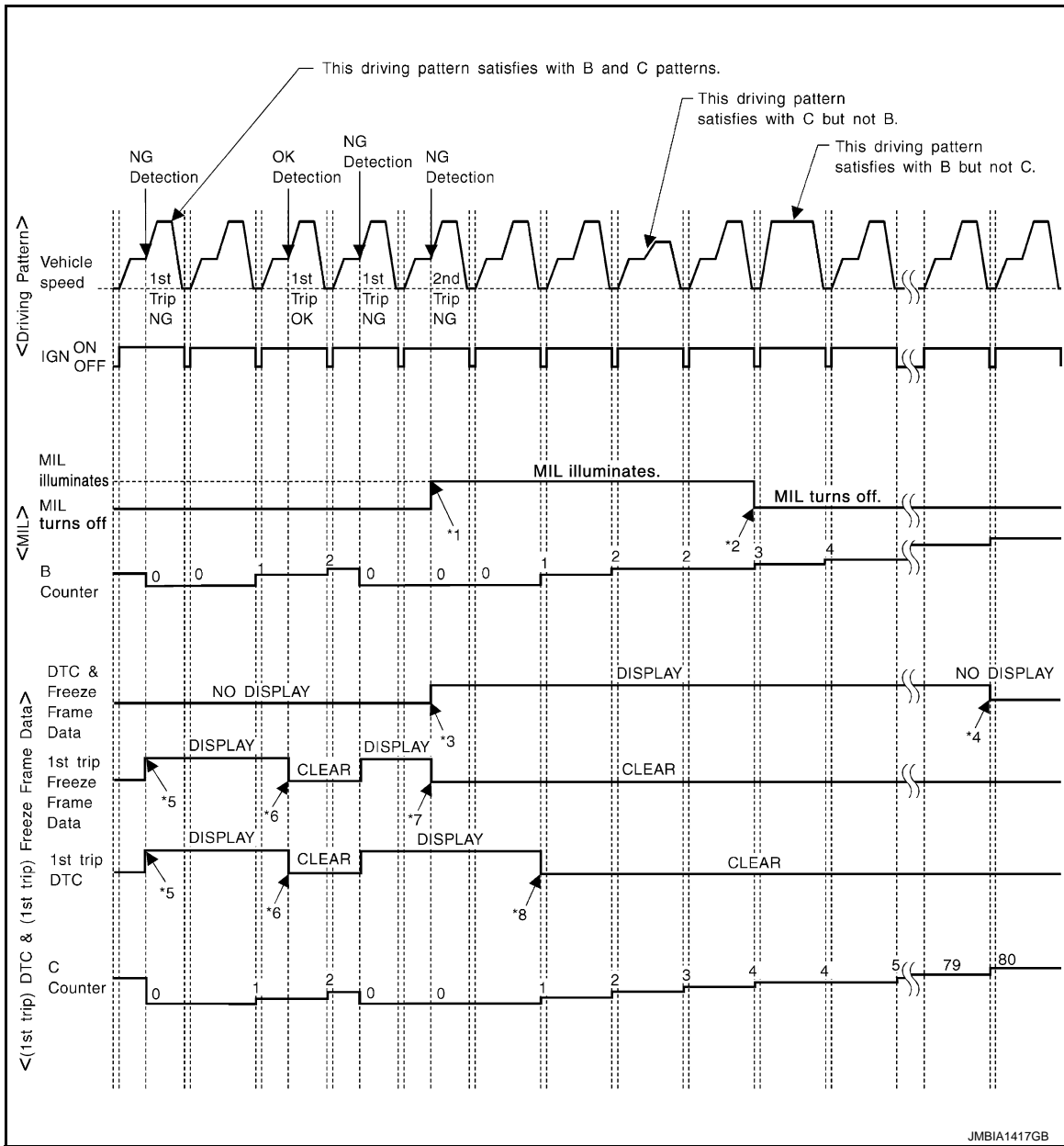

- \*1: When the same malfunction is detected in two consecutive trips, MIL will light up.
- \*2: MIL will turn OFF after vehicle is driven 3 times (pattern B) without any malfunctions.
- \*3: When the same malfunction is detected in two consecutive trips, the DTC and the freeze frame data will be stored in ECM.
- \*4: The DTC and the freeze frame data will not be displayed any longer after vehicle is driven 80 times (pattern C) without the same malfunction. (The DTC and the freeze frame data still remain in ECM.)
- \*5: When a malfunction is detected for the first time, the 1st trip DTC and the 1st trip freeze frame data will be stored in ECM.
- \*6: The 1st trip DTC and the 1st trip freeze frame data will be cleared at the moment OK is detected.
- \*7: When the same malfunction is detected in the 2nd trip, the 1st trip freeze frame data will be cleared.
- \*8: 1st trip DTC will be cleared when vehicle is driven once (pattern C) without the same malfunction after DTC is stored in ECM.

Explanation for Driving Patterns for "Misfire <Exhaust Quality Deterioration>", "Fuel Injection System"

Driving Pattern B

Refer to [EC-1038. "DIAGNOSIS DESCRIPTION : Driving Pattern"](#).

# DIAGNOSIS SYSTEM (ECM)

[VK56VD FOR USA AND CANADA]

## < SYSTEM DESCRIPTION >

### Driving Pattern C

Refer to [EC-1038](#), "DIAGNOSIS DESCRIPTION : Driving Pattern".

Example:

If the stored freeze frame data is as per the following:

Engine speed: 850 rpm, Calculated load value: 30%, Engine coolant temperature: 80°C (176°F)

To be satisfied with driving pattern C, the vehicle should run under the following conditions:

Engine speed: 475 – 1,225 rpm, Calculated load value: 27 – 33%, Engine coolant temperature: more than 70°C (158°F)

Relationship Between MIL, DTC, 1st Trip DTC and Driving Patterns Except For "Misfire <Exhaust Quality Deterioration>", "Fuel Injection System"

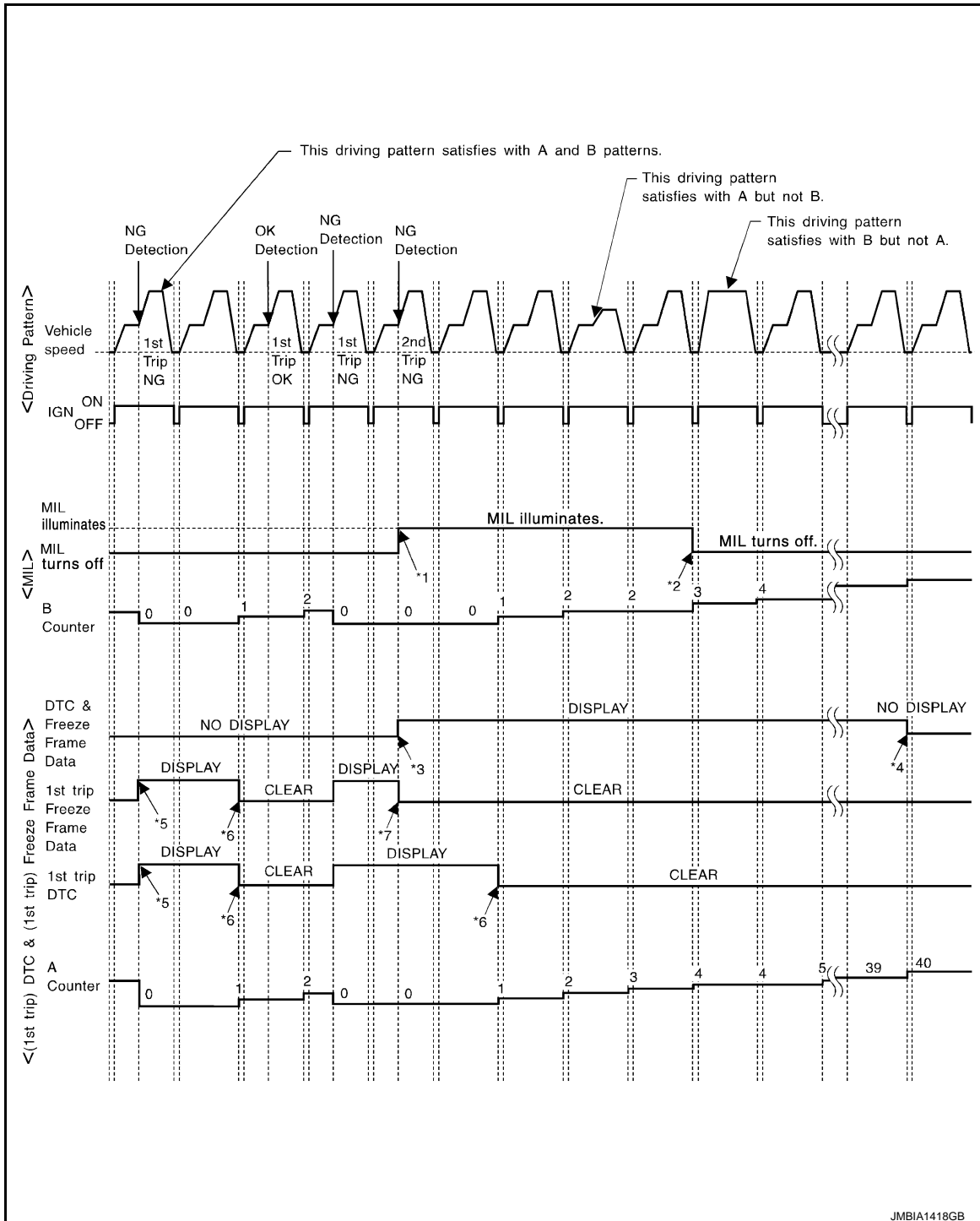

JMBIA1418GB

# DIAGNOSIS SYSTEM (ECM)

[VK56VD FOR USA AND CANADA]

## < SYSTEM DESCRIPTION >

- \*1: When the same malfunction is detected in two consecutive trips, MIL will light up.
- \*2: MIL will turn OFF after vehicle is driven 3 times (pattern B) without any malfunctions.
- \*3: When the same malfunction is detected in two consecutive trips, the DTC and the freeze frame data will be stored in ECM.
- \*4: The DTC and the freeze frame data will not be displayed any longer after vehicle is driven 40 times (pattern A) without the same malfunction. (The DTC and the freeze frame data still remain in ECM.)
- \*5: When a malfunction is detected for the first time, the 1st trip DTC and the 1st trip freeze frame data will be stored in ECM.
- \*6: 1st trip DTC will be cleared after vehicle is driven once (pattern B) without the same malfunction.
- \*7: When the same malfunction is detected in the 2nd trip, the 1st trip freeze frame data will be cleared.

Explanation for Driving Patterns Except for “Misfire <Exhaust Quality Deterioration>”, “Fuel Injection System”

Driving Pattern A

Refer to [EC-1038, "DIAGNOSIS DESCRIPTION : Driving Pattern"](#).

Driving Pattern B

Refer to [EC-1038, "DIAGNOSIS DESCRIPTION : Driving Pattern"](#).

## DIAGNOSIS DESCRIPTION : Driving Pattern

INFOID:000000007229409

### **CAUTION:**

**Always drive at a safe speed.**

### DRIVING PATTERN A

Driving pattern A means a trip satisfying the following conditions.

- Engine speed reaches 400 rpm or more.
- Engine coolant temperature rises by 20°C (32°F) or more after starting the engine.
- Engine coolant temperature reaches 70°C (158°F) or more.
- The ignition switch is turned from ON to OFF.

#### **NOTE:**

- When the same malfunction is detected regardless of driving conditions, reset the counter of driving pattern A.
- When the above conditions are satisfied without detecting the same malfunction, reset the counter of driving pattern A.

### DRIVING PATTERN B

Driving pattern B means a trip satisfying the following conditions.

- Engine speed reaches 400 rpm or more.
- Engine coolant temperature reaches 70°C (158°F) or more.
- Vehicle speed of 70 – 120 km/h (44 – 75 MPH) is maintained for 60 seconds or more under the control of closed loop.
- Vehicle speed of 30 – 60 km/h (19 – 37 MPH) is maintained for 10 seconds or more under the control of closed loop.
- Under the closed loop control condition, the following state reaches 12 seconds or more in total: Vehicle speed of 4 km/h (2 MPH) or less with idling condition.
- The state of driving at 10 km/h (7 MPH) or more reaches 10 minutes or more in total.
- A lapse of 22 minutes or more after engine start.

#### **NOTE:**

- Drive the vehicle at a constant velocity.
- When the same malfunction is detected regardless of driving conditions, reset the counter of driving pattern B.
- When the above conditions are satisfied without detecting the same malfunction, reset the counter of driving pattern B.

### DRIVING PATTERN C

Driving pattern C means operating vehicle as per the following:

The following conditions should be satisfied at the same time:

Engine speed: (Engine speed in the freeze frame data)  $\pm 375$  rpm

# DIAGNOSIS SYSTEM (ECM)

[VK56VD FOR USA AND CANADA]

## < SYSTEM DESCRIPTION >

Calculated load value: (Calculated load value in the freeze frame data) x (1±0.1) [%]

Engine coolant temperature condition:

- When the freeze frame data shows lower than 70°C (158°F), engine coolant temperature should be lower than 70°C (158°F).
- When the freeze frame data shows higher than or equal to 70°C (158°F), engine coolant temperature should be higher than or equal to 70°C (158°F).

### NOTE:

- When the same malfunction is detected regardless of the above vehicle conditions, reset the counter of driving pattern C.
- When the above conditions are satisfied without detecting the same malfunction, reset the counter of driving pattern C.
- The 1st trip DTC will be cleared when C counter is counted once without the same malfunction after DTC is stored in ECM.

## DRIVING PATTERN D

Driving pattern D means a trip satisfying the following conditions.

- The state of driving at 40 km/h (25 MPH) reaches 300 seconds or more in total.
- Idle speed lasts 30 seconds or more.
- A lapse of 600 seconds or more after engine start.

### NOTE:

- When the same malfunction is detected regardless of driving conditions, reset the counter of driving pattern D.
- When the above conditions are satisfied without detecting the same malfunction, reset the counter of driving pattern D.

## DIAGNOSIS DESCRIPTION : System Readiness Test (SRT) Code

INFOID:000000007229410

System Readiness Test (SRT) code is specified in Service \$01 of SAE J1979/ISO 15031-5.

As part of an enhanced emissions test for Inspection & Maintenance (I/M), certain states require the status of SRT be used to indicate whether the ECM has completed self-diagnosis of major emission systems and components. Completion must be verified in order for the emissions inspection to proceed.

If a vehicle is rejected for a State emissions inspection due to one or more SRT items indicating "INCMP", use the information in this Service Manual to set the SRT to "CMPLT".

In most cases the ECM will automatically complete its self-diagnosis cycle during normal usage, and the SRT status will indicate "CMPLT" for each application system. Once set as "CMPLT", the SRT status remains "CMPLT" until the self-diagnosis memory is erased.

Occasionally, certain portions of the self-diagnostic test may not be completed as a result of the customer's normal driving pattern; the SRT will indicate "INCMP" for these items.

### NOTE:

The SRT will also indicate "INCMP" if the self-diagnosis memory is erased for any reason or if the ECM memory power supply is interrupted for several hours.

If, during the state emissions inspection, the SRT indicates "CMPLT" for all test items, the inspector will continue with the emissions test. However, if the SRT indicates "INCMP" for one or more of the SRT items the vehicle is returned to the customer untested.

### NOTE:

If MIL is ON during the state emissions inspection, the vehicle is also returned to the customer untested even though the SRT indicates "CMPLT" for all test items. Therefore, it is important to check SRT ("CMPLT") and DTC (No DTCs) before the inspection.

## SRT SET TIMING

SRT is set as "CMPLT" after self-diagnosis has been performed one or more times. Completion of SRT is done regardless of whether the result is OK or NG. The set timing is different between OK and NG results and is shown in the table below.

# DIAGNOSIS SYSTEM (ECM)

[VK56VD FOR USA AND CANADA]

< SYSTEM DESCRIPTION >

| Self-diagnosis result |        | Example        |                |         |              |                        |        |     |
|-----------------------|--------|----------------|----------------|---------|--------------|------------------------|--------|-----|
|                       |        | Diagnosis      | Ignition cycle |         |              |                        |        |     |
|                       |        |                | ← ON →         | OFF     | ← ON →       | OFF                    | ← ON → | OFF |
| All OK                | Case 1 | P0400          | OK (1)         | — (1)   | OK (2)       | — (2)                  |        |     |
|                       |        | P0402          | OK (1)         | — (1)   | — (1)        | OK (2)                 |        |     |
|                       |        | P1402          | OK (1)         | OK (2)  | — (2)        | — (2)                  |        |     |
|                       |        | SRT of EGR     | “CMPLT”        | “CMPLT” | “CMPLT”      | “CMPLT”                |        |     |
|                       | Case 2 | P0400          | OK (1)         | — (1)   | — (1)        | — (1)                  |        |     |
|                       |        | P0402          | — (0)          | — (0)   | OK (1)       | — (1)                  |        |     |
|                       |        | P1402          | OK (1)         | OK (2)  | — (2)        | — (2)                  |        |     |
|                       |        | SRT of EGR     | “INCMP”        | “INCMP” | “CMPLT”      | “CMPLT”                |        |     |
| NG exists             | Case 3 | P0400          | OK             | OK      | —            | —                      |        |     |
|                       |        | P0402          | —              | —       | —            | —                      |        |     |
|                       |        | P1402          | NG             | —       | NG           | NG<br>(Consecutive NG) |        |     |
|                       |        | (1st trip) DTC | 1st trip DTC   | —       | 1st trip DTC | DTC<br>(= MIL ON)      |        |     |
|                       |        | SRT of EGR     | “INCMP”        | “INCMP” | “INCMP”      | “CMPLT”                |        |     |

OK: Self-diagnosis is carried out and the result is OK.

NG: Self-diagnosis is carried out and the result is NG.

—: Self-diagnosis is not carried out.

When all SRT related self-diagnoses show OK results in a single cycle (Ignition OFF-ON-OFF), the SRT will indicate “CMPLT”. → Case 1 above

When all SRT related self-diagnoses show OK results through several different cycles, the SRT will indicate “CMPLT” at the time the respective self-diagnoses have at least one OK result. → Case 2 above

If one or more SRT related self-diagnoses show NG results in 2 consecutive cycles, the SRT will also indicate “CMPLT”. → Case 3 above

The table above shows that the minimum number of cycles for setting SRT as “INCMP” is the number one (1) for each self-diagnosis (Case 1 & 2) or the number two (2) for one of self-diagnoses (Case 3). However, in preparation for the state emissions inspection, it is unnecessary for each self-diagnosis to be executed twice (Case 3) for the following reasons:

- The SRT will indicate “CMPLT” at the time the respective self-diagnoses have one (1) OK result.
- The emissions inspection requires “CMPLT” of the SRT only with OK self-diagnosis results.
- During SRT driving pattern, the 1st trip DTC (NG) is detected prior to “CMPLT” of SRT and the self-diagnosis memory must be erased from the ECM after repair.
- If the 1st trip DTC is erased, all the SRT will indicate “INCMP”.

**NOTE:**

SRT can be set as “CMPLT” together with the DTC(s). Therefore, DTC check must always be carried out prior to the state emission inspection even though the SRT indicates “CMPLT”.

## DIAGNOSIS DESCRIPTION : Permanent Diagnostic Trouble Code (Permanent DTC)

INFOID:000000007229411

Permanent DTC is defined in SAE J1979/ISO 15031-5 Service \$0A.

ECM stores a DTC issuing a command of turning on MIL as a permanent DTC and keeps storing the DTC as a permanent DTC until ECM judges that there is no presence of malfunction.

Permanent DTCs cannot be erased by using the erase function of CONSULT or Generic Scan Tool (GST) and by disconnecting the battery to shut off power to ECM. This prevents a vehicle from passing the in-use inspection without repairing a malfunctioning part.

When not passing the state in-use inspection due to more than one permanent DTC, permanent DTCs should be erased, referring to this manual.

**NOTE:**

- The important items in in-use inspection are that MIL is not ON, SRT test items are set, and permanent DTCs are not included.
- Permanent DTCs do not apply for regions that permanent DTCs are not regulated by law.



< SYSTEM DESCRIPTION >

## PERMANENT DTC SET TIMING

The setting timing of permanent DTC is stored in ECM with the lighting of MIL when a DTC is confirmed.

## DIAGNOSIS DESCRIPTION : Malfunction Indicator Lamp (MIL)

INFOID:000000007229412

When emission-related ECU detects a malfunction in the emission control systems components and/or the powertrain control components (which affect vehicle emissions), it turns on/blinks MIL to inform the driver that a malfunction has been detected.

1. The MIL illuminates when ignition switch is turned ON (engine is not running).

**NOTE:**

Check the MIL circuit if MIL does not illuminate. Refer to [EC-1534, "Component Function Check"](#).

2. When the engine is started, the MIL should go off.

**NOTE:**

If MIL continues to illuminate/blink, perform self-diagnoses and inspect/repair accordingly because an emission-related ECU has detected a malfunction in the emission control systems components and/or the powertrain control components (which affect vehicle emissions).

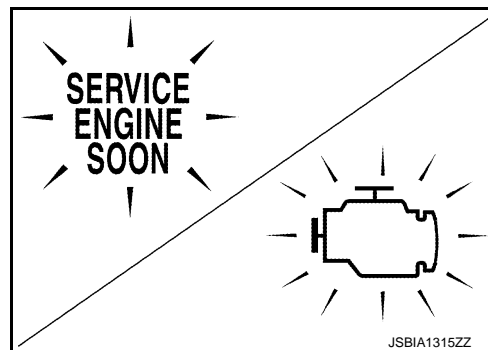

## On Board Diagnosis Function

INFOID:000000007187224

### ON BOARD DIAGNOSIS ITEM

The on board diagnostic system has the following functions.

| Diagnostic test mode                          | Function  |
|---|---|
| Bulb check                                    | MIL can be checked.   |
| SRT status                                    | ECM can read if SRT codes are set.  |
| Malfunction warning                           | If ECM detects a malfunction, it illuminates or blinks MIL to inform the driver that a malfunction has been detected.             |
| Self-diagnostic results                       | DTCs or 1st trip DTCs stored in ECM can be read.  |
| Accelerator pedal released position learning  | ECM can learn the accelerator pedal released position. Refer to <a href="#">EC-1120, "Description"</a> .                          |
| Throttle valve closed position learning       | ECM can learn the throttle valve closed position. Refer to <a href="#">EC-1121, "Description"</a> .                               |
| Idle air volume learning                      | ECM can learn the idle air volume. Refer to <a href="#">EC-1122, "Description"</a> .  |
| VVEL control shaft position sensor adjustment | The initial position of the VVEL control shaft position sensor can be adjusted. Refer to <a href="#">EC-1124, "Description"</a> . |

## BLUB CHECK MODE

### Description

This function allows damage inspection in the MIL bulb (blown, open circuit, etc.).

### Operation Procedure

1. Turn ignition switch ON.
2. The MIL on the instrument panel should stay ON.  
If it remains OFF, check MIL circuit. Refer to [EC-1534, "Diagnosis Procedure"](#).

## SRT STATUS MODE

### Description

This function allows to read if ECM has completed the self-diagnoses of major emission control systems and components. For SRT, refer to [EC-1039, "DIAGNOSIS DESCRIPTION : System Readiness Test \(SRT\) Code"](#).

### Operation Procedure

1. Turn ignition switch ON and wait 20 seconds.
2. SRT status is indicated as shown blow.
  - ECM continues to illuminate MIL if all SRT codes are set.

# DIAGNOSIS SYSTEM (ECM)

[VK56VD FOR USA AND CANADA]

## < SYSTEM DESCRIPTION >

- ECM blinks MIL for about 10 seconds if all SRT codes are not set.

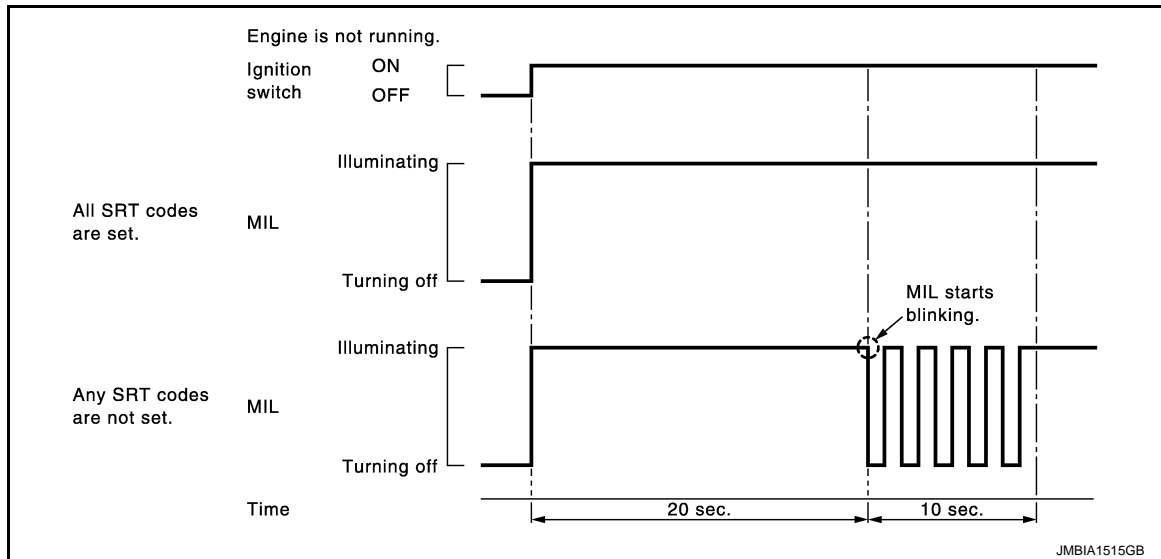

## MALFUNCTION WARNING MODE

### Description

In this function ECM turns on or blinks MIL when it detects a malfunction in the emission control system components and/or the powertrain control components (which affect vehicle emissions) to inform the driver that a malfunction has been detected.

### Operation Procedure

1. Turn ignition switch ON.
2. Check that MIL illuminates.  
If it remains OFF, check MIL circuit. Refer to [EC-1534, "Diagnosis Procedure"](#).
3. Start engine and let it idle.
  - For two trip detection logic diagnoses, ECM turns on MIL when it detects the same malfunction twice in the two consecutive driving cycles.
  - For 1st trip detection logic diagnoses, ECM turns on MIL when it detects a malfunction in one driving cycle.
  - ECM blinks MIL when it detects a malfunction that may damage the three way catalyst (misfire).

## SELF-DIAGNOSTIC RESULTS MODE

### Description

This function allows to indicate DTCs or 1st trip DTCs stored in ECM according to the number of times MIL is blinking.

### How to Set Self-diagnostic Results Mode

#### NOTE:

- It is better to count the time accurately with a clock.
  - It is impossible to switch the diagnostic mode when an accelerator pedal position sensor circuit has a malfunction.
  - After ignition switch is turned off, ECM is always released from the "Self-diagnostic results" mode.
1. Confirm that accelerator pedal is fully released, turn ignition switch ON and wait 3 seconds.
  2. Repeat the following procedure quickly five times within 5 seconds.
    - Fully depress the accelerator pedal.
    - Fully release the accelerator pedal.
  3. Wait 7 seconds, fully depress the accelerator pedal and keep it depressed for approx. 10 seconds until the MIL starts blinking.

#### NOTE:

Do not release the accelerator pedal for 10 seconds if MIL starts blinking during this period. This blinking is displaying SRT status and is continued for another 10 seconds.

4. Fully release the accelerator pedal.  
ECM has entered to "Self-diagnostic results" mode.

# DIAGNOSIS SYSTEM (ECM)

[VK56VD FOR USA AND CANADA]

## < SYSTEM DESCRIPTION >

### NOTE:

Wait until the same DTC (or 1st trip DTC) appears to completely confirm all DTCs.

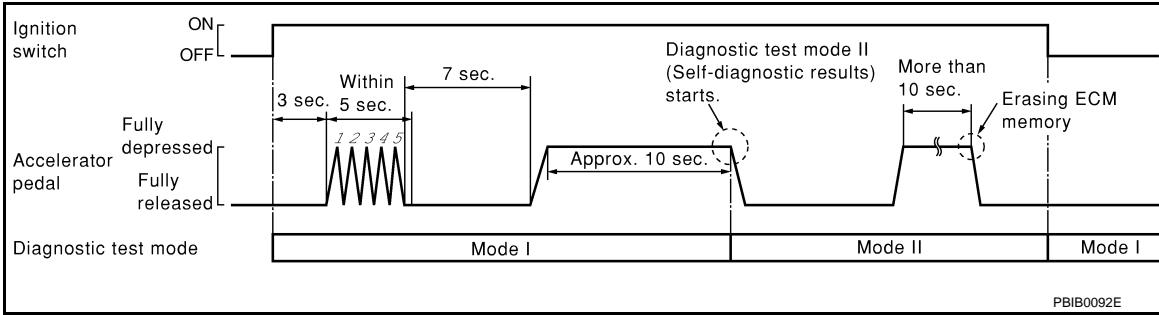

### How to Read Self-diagnostic Results

The DTC and 1st trip DTC are indicated by the number of blinks of the MIL as shown below.

The DTC and 1st trip DTC are displayed at the same time. If the MIL does not illuminate in diagnostic test mode I (Malfunction warning), all displayed items are 1st trip DTCs. If only one code is displayed when the MIL illuminates in "malfunction warning" mode, it is a DTC; if two or more codes are displayed, they may be either DTCs or 1st trip DTCs. DTC No. is same as that of 1st trip DTC. These unidentified codes can be identified by using the CONSULT or GST. A DTC will be used as an example for how to read a code.

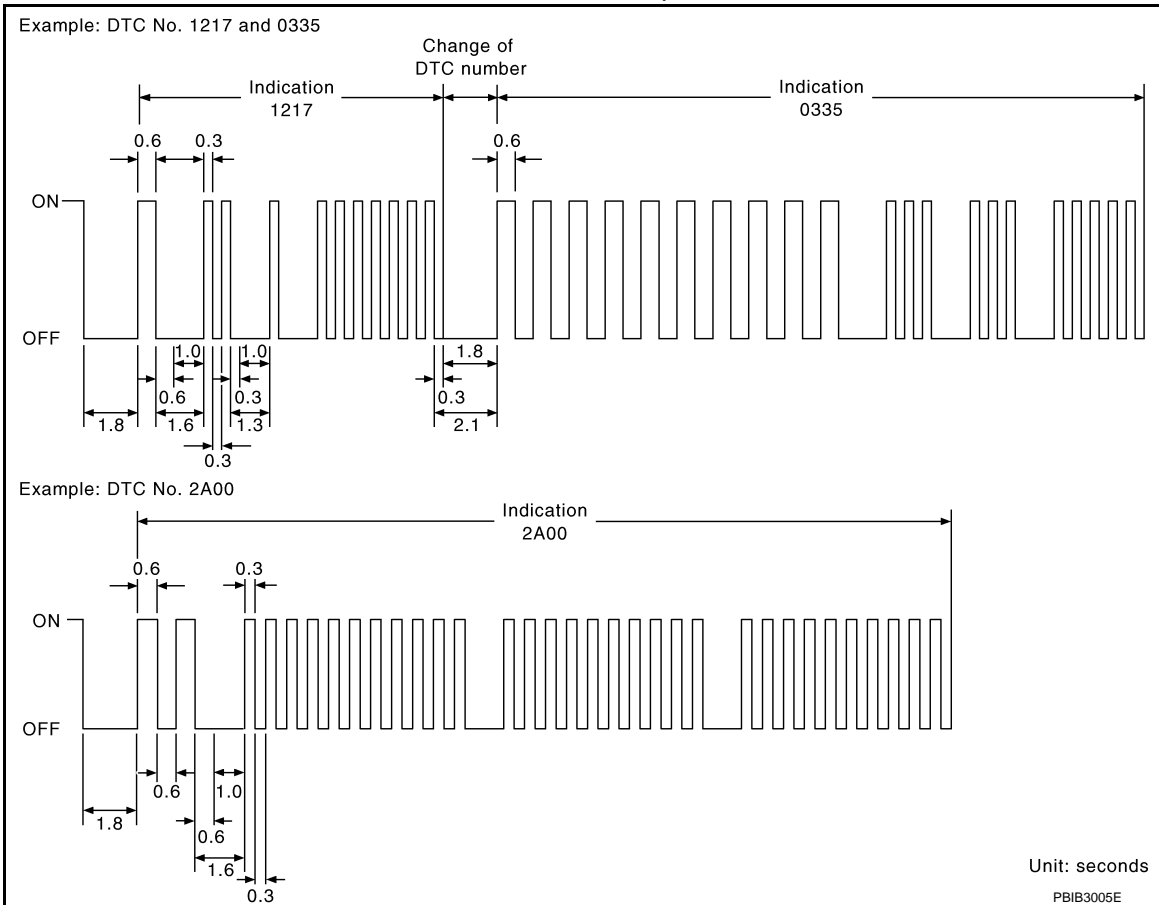

A particular trouble code can be identified by the number of four-digit numeral flashes per the following.

| Number  | 0  | 1 | 2 | 3 | 4 | 5 | 6 | 7 | 8 | 9 | A  | B  | C  | D  | E  | F  |
|---------|----|---|---|---|---|---|---|---|---|---|----|----|----|----|----|----|
| Flashes | 10 | 1 | 2 | 3 | 4 | 5 | 6 | 7 | 8 | 9 | 11 | 12 | 13 | 14 | 15 | 16 |

The length of time the 1,000th-digit numeral flashes on and off is 1.2 seconds consisting of an ON (0.6-seconds) - OFF (0.6-seconds) cycle.

The 100th-digit numeral and lower digit numerals consist of a 0.3-seconds ON and 0.3-seconds OFF cycle.

A change from one digit numeral to another occurs at an interval of 1.0-second OFF. In other words, the later numeral appears on the display 1.3 seconds after the former numeral has disappeared.

A change from one trouble code to another occurs at an interval of 1.8-seconds OFF.

# DIAGNOSIS SYSTEM (ECM)

[VK56VD FOR USA AND CANADA]

## < SYSTEM DESCRIPTION >

In this way, all the detected malfunctions are classified by their DTC numbers. The DTC 0000 refers to no malfunction. Refer to [EC-1083, "DTC Index"](#).

### How to Erase Self-diagnostic Results

By performing this procedure, ECM memory is erased and the following diagnostic information is erased as well.

- Diagnostic trouble codes
- 1st trip diagnostic trouble codes
- Freeze frame data
- 1st trip freeze frame data
- System readiness test (SRT) codes
- Test values

#### **NOTE:**

Also, if a battery terminal is disconnected, ECM memory is erased and the diagnostic information as listed above is erased. (The amount of time required for erasing may vary from a few seconds to several hours.)

1. Turn ignition switch OFF and wait at least 10 seconds.
2. Turn ignition switch ON.
3. Turn ignition switch OFF and wait at least 10 seconds.
4. Turn ignition switch ON.
5. Set ECM in "Self-diagnostic results" mode.
6. The diagnostic information has been erased from the backup memory in the ECM.  
Fully depress the accelerator pedal and keep it depressed for more than 10 seconds.
7. Fully release the accelerator pedal, and confirm the DTC 0000 is displayed.

## CONSULT Function

INFOID:000000007187225

### FUNCTION

| Diagnostic test mode   | Function  |
|------------------------|---|
| Work support           | This mode enables a technician to adjust some devices faster and more accurately by following the indications on the CONSULT unit.      |
| Self diagnostic result | Self-diagnostic results such as 1st trip DTC, DTCs and 1st trip freeze frame data or freeze frame data can be read and erased quickly.* |
| Data monitor           | Input/Output data in the ECM can be read.   |
| Active test            | Diagnostic Test Mode in which CONSULT drives some actuators apart from the ECMs and also shifts some parameters in a specified range.   |
| DTC & SRT confirmation | The status of system monitoring tests and the self-diagnosis status/results can be confirmed.   |
| Function test          | This mode is used to inform customers when the vehicle requires periodic maintenance.   |
| ECU identification     | ECM part number can be read.  |

\*: The following emission-related diagnostic information is cleared when the ECM memory is erased.

- Diagnostic trouble codes
- 1st trip diagnostic trouble codes
- Freeze frame data
- 1st trip freeze frame data
- System readiness test (SRT) codes
- Test values

## WORK SUPPORT MODE

### Work Item

# DIAGNOSIS SYSTEM (ECM)

< SYSTEM DESCRIPTION >

[VK56VD FOR USA AND CANADA]

| WORK ITEM             | CONDITION  | USAGE   |
|-----------------------|--|---|
| IDLE AIR VOL LEARN    | <ul style="list-style-type: none"> <li>The idle air volume that keeps the engine speed within the specified range is memorized in ECM.</li> </ul>  | When learning the idle air volume                 |
| EVAP SYSTEM CLOSE     | <p>Close the EVAP canister vent control valve in order to make EVAP system close under the following conditions.</p> <ul style="list-style-type: none"> <li>Ignition switch ON</li> <li>Engine not running</li> <li>Ambient air temperature is above 0°C (32°F).</li> <li>No vacuum and no high pressure in EVAP system</li> <li>Fuel tank temperature is more than 0°C (32°F).</li> <li>Within 10 minutes after starting "EVAP SYSTEM CLOSE"</li> <li>When trying to execute "EVAP SYSTEM CLOSE" under the condition except above, CONSULT will discontinue it and display appropriate instruction.</li> </ul> <p><b>NOTE:</b><br/>When starting engine, CONSULT may display "Battery voltage is low. Charge battery", even when using a charged battery.</p> | When detecting EVAP vapor leak in the EVAP system |
| FUEL PRESSURE RELEASE | <ul style="list-style-type: none"> <li>Fuel pump will stop by touching "START" during idling. Crank a few times after engine stalls.</li> </ul>  | When releasing fuel pressure from fuel line       |
| SELF-LEARNING CONT    | <ul style="list-style-type: none"> <li>The coefficient of self-learning control mixture ratio returns to the original coefficient.</li> </ul>  | When clearing mixture ratio self-learning value   |
| VIN REGISTRATION      | <ul style="list-style-type: none"> <li>VIN can be registered in ECM.</li> </ul>  | When registering VIN in ECM                       |
| VVEL POS SEN ADJ PREP | <ul style="list-style-type: none"> <li>Use this item only when replacing VVEL actuator sub assembly.</li> <li>Ignition switch ON and engine stopped</li> </ul>   | When adjusting VVEL control shaft position sensor |
| TARGET IDLE RPM ADJ*  | <ul style="list-style-type: none"> <li>Idle condition</li> </ul>   | When setting target idle speed                    |
| TARGET IGN TIM ADJ*   | <ul style="list-style-type: none"> <li>Idle condition</li> </ul>   | When adjusting target ignition timing             |
| CLSD THL POS LEARN    | <ul style="list-style-type: none"> <li>Ignition switch ON and engine stopped</li> </ul>  | When learning the throttle valve closed position  |

\*: This function is not necessary in the usual service procedure.

## SELF-DIAG RESULTS MODE

### Self Diagnostic Item

Regarding items of DTC and 1st trip DTC, refer to [EC-1083, "DTC Index"](#).

### How to Read DTC and 1st Trip DTC

DTCs and 1st trip DTCs related to the malfunction are displayed in "Self-diag results".

- When ECM detects a 1st trip DTC, "1t" is displayed for "TIME".
- When ECM has detected a current DTC, "0" is displayed for "TIME".
- If "TIME" is neither "0" nor "1t", the DTC occurred in the past and ECM shows the number of times the vehicle has been driven since the last detection of the DTC.

### How to Erase DTC and 1st Trip DTC

#### NOTE:

- If the ignition switch stays ON after repair work, be sure to turn ignition switch OFF once. Wait at least 10 seconds and then turn it ON (engine stopped) again.
- If the DTC is not for A/T related items (see [EC-1083, "DTC Index"](#)), skip step 1.
  - Erase DTC in TCM. Refer to [TM-59, "Diagnosis Description"](#).
  - Select "ENGINE" with CONSULT.
  - Select "SELF-DIAG RESULTS".
  - Touch "ERASE". (DTC in ECM will be erased.)

### Freeze Frame Data and 1st Trip Freeze Frame Data

# DIAGNOSIS SYSTEM (ECM)

[VK56VD FOR USA AND CANADA]

## < SYSTEM DESCRIPTION >

| Freeze frame data item*      | Description   |
|------------------------------|---|
| DIAG TROUBLE CODE [PXXXX]    | <ul style="list-style-type: none"> <li>The engine control component part/control system has a trouble code the is displayed as PXXXX. (Refer to <a href="#">EC-1083, "DTC Index".</a>)</li> </ul>   |
| CAL/LD VALUE [%]             | <ul style="list-style-type: none"> <li>The calculated load value at the moment a malfunction is detected is displayed.</li> </ul>   |
| COOLANT TEMP [°C] or [°F]    | <ul style="list-style-type: none"> <li>The engine coolant temperature at the moment a malfunction is detected is displayed.</li> </ul>  |
| L-FUEL TRM-B1 [%]            | <ul style="list-style-type: none"> <li>"Long-term fuel trim" at the moment a malfunction is detected is displayed.</li> <li>The long-term fuel trim indicates much more gradual feedback compensation to the base fuel schedule than short-term fuel trim.</li> </ul>   |
| L-FUEL TRM-B2 [%]            |   |
| S-FUEL TRM-B1 [%]            | <ul style="list-style-type: none"> <li>"Short-term fuel trim" at the moment a malfunction is detected is displayed.</li> <li>The short-term fuel trim indicates dynamic or instantaneous feedback compensation to the base fuel schedule.</li> </ul>  |
| S-FUEL TRM-B2 [%]            |   |
| ENGINE SPEED [rpm]           | <ul style="list-style-type: none"> <li>The engine speed at the moment a malfunction is detected is displayed.</li> </ul>  |
| VEHICL SPEED [km/h] or [mph] | <ul style="list-style-type: none"> <li>The vehicle speed at the moment a malfunction is detected is displayed.</li> </ul>   |
| INT MANI PRES [kPa]          | <ul style="list-style-type: none"> <li>These items are displayed but are not applicable to this model.</li> </ul>   |
| ABSOL TH-P/S [%]             | <ul style="list-style-type: none"> <li>The throttle valve opening angle at the moment a malfunction is detected is displayed.</li> </ul>  |
| B/FUEL SCHDL [msec]          | <ul style="list-style-type: none"> <li>The base fuel schedule at the moment a malfunction is detected is displayed.</li> </ul>  |
| INT/A TEMP SE [°C] or [°F]   | <ul style="list-style-type: none"> <li>The intake air temperature at the moment a malfunction is detected is displayed.</li> </ul>  |
| FUEL SYS-B1                  | <ul style="list-style-type: none"> <li>"Fuel injection system status" at the moment a malfunction is detected is displayed.</li> <li>One of the following mode is displayed.<br/>                     Mode2: Open loop due to detected system malfunction<br/>                     Mode3: Open loop due to driving conditions (power enrichment, deceleration enleanment)<br/>                     Mode4: Closed loop - using oxygen sensor(s) as feedback for fuel control<br/>                     Mode5: Open loop - has not yet satisfied condition to go to closed loop</li> </ul> |
| FUEL SYS-B2                  |   |
| COMBUST CONDITON             | <ul style="list-style-type: none"> <li>These items are displayed but are not applicable to this model.</li> </ul>   |

\*: The items are the same as those of 1st trip freeze frame data.

## DATA MONITOR MODE

### Monitored Item

×: Applicable

| Monitored item | Unit | Description  | Remarks   |
|----------------|------|--|---|
| ENG SPEED      | rpm  | <ul style="list-style-type: none"> <li>Indicates the engine speed computed from the signal of the crankshaft position sensor and camshaft position sensor.</li> </ul>          | <ul style="list-style-type: none"> <li>Accuracy becomes poor if engine speed drops below the idle rpm.</li> <li>If the signal is interrupted while the engine is running, an abnormal value may be indicated.</li> </ul>  |
| MAS A/F SE-B1  | V    | <ul style="list-style-type: none"> <li>The signal voltage of the mass air flow sensor is displayed.</li> </ul>   | <ul style="list-style-type: none"> <li>When the engine is stopped, a certain value is indicated.</li> <li>When engine is running, specification range is indicated in "SPEC".</li> </ul>  |
| MAS A/F SE-B2  |      |  |   |
| B/FUEL SCHDL   | msec | <ul style="list-style-type: none"> <li>"Base fuel schedule" indicates the fuel injection pulse width programmed into ECM, prior to any learned on board correction.</li> </ul> | <ul style="list-style-type: none"> <li>When engine is running, specification range is indicated in "SPEC".</li> </ul>   |
| A/F ALPHA-B1   | %    | <ul style="list-style-type: none"> <li>The mean value of the air-fuel ratio feedback correction factor per cycle is indicated.</li> </ul>                                      | <ul style="list-style-type: none"> <li>When the engine is stopped, a certain value is indicated.</li> <li>This data also includes the data for the air-fuel ratio learning control.</li> <li>When engine is running, specification range is indicated in "SPEC".</li> </ul> |
| A/F ALPHA-B2   |      |  |   |

# DIAGNOSIS SYSTEM (ECM)

[VK56VD FOR USA AND CANADA]

## < SYSTEM DESCRIPTION >

| Monitored item  | Unit        | Description   | Remarks  |
|-----------------|-------------|---|--|
| COOLAN TEMP/S   | °C or °F    | <ul style="list-style-type: none"> <li>The engine coolant temperature (determined by the signal voltage of the engine coolant temperature sensor) is displayed.</li> </ul>  | <ul style="list-style-type: none"> <li>When the engine coolant temperature sensor is open or short-circuited, ECM enters fail-safe mode. The engine coolant temperature determined by the ECM is displayed.</li> </ul> |
| A/F SEN1 (B1)   | V           | <ul style="list-style-type: none"> <li>The A/F signal computed from the input signal of the air fuel ratio (A/F) sensor 1 is displayed.</li> </ul>  |  |
| A/F SEN1 (B2)   |             |   |  |
| HO2S2 (B1)      | V           | <ul style="list-style-type: none"> <li>The signal voltage of the heated oxygen sensor 2 is displayed.</li> </ul>  |  |
| HO2S2 (B2)      |             |   |  |
| HO2S2 MNTR (B1) | RICH/LEAN   | <ul style="list-style-type: none"> <li>Display of heated oxygen sensor 2 signal:<br/>RICH: means the amount of oxygen after three way catalyst is relatively small.<br/>LEAN: means the amount of oxygen after three way catalyst is relatively large.</li> </ul>           | <ul style="list-style-type: none"> <li>When the engine is stopped, a certain value is indicated.</li> </ul>  |
| HO2S2 MNTR (B2) |             |   |  |
| VHCL SPEED SE   | km/h or mph | <ul style="list-style-type: none"> <li>The vehicle speed computed from the vehicle speed signal sent from combination meter is displayed.</li> </ul>  |  |
| BATTERY VOLT    | V           | <ul style="list-style-type: none"> <li>The power supply voltage of ECM is displayed.</li> </ul>   |  |
| ACCEL SEN 1     | V           | <ul style="list-style-type: none"> <li>The accelerator pedal position sensor signal voltage is displayed.</li> </ul>  | <ul style="list-style-type: none"> <li>ACCEL SEN 2 signal is converted by ECM internally. Thus, they differs from ECM terminal voltage signal.</li> </ul>  |
| ACCEL SEN 2     |             |   |  |
| TP SEN 1-B1     | V           | <ul style="list-style-type: none"> <li>The throttle position sensor signal voltage is displayed.</li> </ul>   | <ul style="list-style-type: none"> <li>TP SEN 2-B1 signal is converted by ECM internally. Thus, they differs from ECM terminal voltage signal.</li> </ul>  |
| TP SEN 2-B1     |             |   |  |
| FUEL T/TMP SE   | °C or °F    | <ul style="list-style-type: none"> <li>The fuel temperature (determined by the signal voltage of the fuel tank temperature sensor) is displayed.</li> </ul>   |  |
| EVAP SYS PRES   | V           | <ul style="list-style-type: none"> <li>The signal voltage of EVAP control system pressure sensor is displayed.</li> </ul>   |  |
| FUEL LEVEL SE   | V           | <ul style="list-style-type: none"> <li>The signal voltage of the fuel level sensor is displayed.</li> </ul>   |  |
| START SIGNAL    | ON/OFF      | <ul style="list-style-type: none"> <li>Indicates start signal status [ON/OFF] computed by the ECM according to the signals of engine speed and battery voltage.</li> </ul>  | <ul style="list-style-type: none"> <li>After starting the engine, [OFF] is displayed regardless of the starter signal.</li> </ul>  |
| CLSD THL POS    | ON/OFF      | <ul style="list-style-type: none"> <li>Indicates idle position [ON/OFF] computed by ECM according to the accelerator pedal position sensor signal.</li> </ul>   |  |
| AIR COND SIG    | ON/OFF      | <ul style="list-style-type: none"> <li>Indicates [ON/OFF] condition of the air conditioner switch as determined by the air conditioner signal.</li> </ul>   |  |
| PW/ST SIGNAL    | ON/OFF      | <ul style="list-style-type: none"> <li>[ON/OFF] condition of the power steering system (determined by the signal voltage of the power steering pressure sensor signal) is indicated.</li> </ul>   |  |
| LOAD SIGNAL     | ON/OFF      | <ul style="list-style-type: none"> <li>Indicates [ON/OFF] condition from the electrical load signal.<br/>ON: Rear window defogger switch is ON and/or lighting switch is in 2nd position.<br/>OFF: Both rear window defogger switch and lighting switch are OFF.</li> </ul> |  |
| IGNITION SW     | ON/OFF      | <ul style="list-style-type: none"> <li>Indicates [ON/OFF] condition from ignition switch signal.</li> </ul>   |  |
| HEATER FAN SW   | ON/OFF      | <ul style="list-style-type: none"> <li>Indicates [ON/OFF] condition from the heater blower ON signal.</li> </ul>  |  |
| BRAKE SW        | ON/OFF      | <ul style="list-style-type: none"> <li>Indicates [ON/OFF] condition from the stop lamp switch signal.</li> </ul>  |  |

# DIAGNOSIS SYSTEM (ECM)

[VK56VD FOR USA AND CANADA]

< SYSTEM DESCRIPTION >

| Monitored item  | Unit        | Description  | Remarks  |
|-----------------|-------------|--|--|
| INJ PULSE-B1    | msec        | <ul style="list-style-type: none"> <li>Indicates the actual fuel injection pulse width compensated by ECM according to the input signals.</li> </ul>   | <ul style="list-style-type: none"> <li>When the engine is stopped, a certain computed value is indicated.</li> </ul> |
| INJ PULSE-B2    |             |  |  |
| IGN TIMING      | BTDC        | <ul style="list-style-type: none"> <li>Indicates the ignition timing computed by ECM according to the input signals.</li> </ul>  | <ul style="list-style-type: none"> <li>When the engine is stopped, a certain value is indicated.</li> </ul>          |
| COMBUSTION      | —           | <ul style="list-style-type: none"> <li>These items are displayed but are not applicable to this model.</li> </ul>  |  |
| CAL/LD VALUE    | %           | <ul style="list-style-type: none"> <li>"Calculated load value" indicates the value of the current air flow divided by peak air flow.</li> </ul>  |  |
| MASS AIRFLOW    | g/s         | <ul style="list-style-type: none"> <li>Indicates the mass air flow computed by ECM according to the signal voltage of the mass air flow sensor.</li> </ul>   |  |
| PURG VOL C/V    | %           | <ul style="list-style-type: none"> <li>Indicates the EVAP canister purge volume control solenoid valve control value computed by the ECM according to the input signals.</li> <li>The opening becomes larger as the value increases.</li> </ul>  |  |
| EXH/V TIM B1    | °CA         | <ul style="list-style-type: none"> <li>Indicates [°CA] of exhaust camshaft retard angle.</li> </ul>  |  |
| EXH/V TIM B2    |             |  |  |
| INT/V SOL (B1)  | %           | <ul style="list-style-type: none"> <li>The control value of the intake valve timing control solenoid valve (determined by ECM according to the input signals) is indicated.</li> <li>The advance angle becomes larger as the value increases.</li> </ul>   |  |
| INT/V SOL (B2)  |             |  |  |
| AIR COND RLY    | ON/OFF      | <ul style="list-style-type: none"> <li>The air conditioner relay control condition (determined by ECM according to the input signals) is indicated.</li> </ul>   |  |
| VENT CONT/V     | ON/OFF      | <ul style="list-style-type: none"> <li>The control condition of the EVAP canister vent control valve (determined by ECM according to the input signals) is indicated.</li> <li>ON: Closed</li> <li>OFF: Open</li> </ul>  |  |
| THRTL RELAY     | ON/OFF      | <ul style="list-style-type: none"> <li>Indicates the throttle control motor relay control condition determined by the ECM according to the input signals.</li> </ul>   |  |
| A/F S1 HTR (B1) | %           | <ul style="list-style-type: none"> <li>Air fuel ratio (A/F) sensor 1 heater control value computed by ECM according to the input signals.</li> <li>The current flow to the heater becomes larger as the value increases.</li> </ul>  |  |
| A/F S1 HTR (B2) |             |  |  |
| HO2S2 HTR (B1)  | ON/OFF      | <ul style="list-style-type: none"> <li>Indicates [ON/OFF] condition of heated oxygen sensor 2 heater determined by ECM according to the input signals.</li> </ul>  |  |
| HO2S2 HTR (B2)  |             |  |  |
| ALT DUTY SIG    | ON/OFF      | <ul style="list-style-type: none"> <li>The control condition of the power generation voltage variable control (determined by ECM according to the input signals) is indicated.</li> <li>ON: Power generation voltage variable control is active.</li> <li>OFF: Power generation voltage variable control is inactive.</li> </ul> |  |
| I/P PULLY SPD   | rpm         | <ul style="list-style-type: none"> <li>Indicates the engine speed computed from the input speed sensor signal.</li> </ul>  |  |
| VEHICLE SPEED   | km/h or mph | <ul style="list-style-type: none"> <li>The vehicle speed computed from the vehicle speed signal sent from TCM is displayed.</li> </ul>   |  |



# DIAGNOSIS SYSTEM (ECM)

[VK56VD FOR USA AND CANADA]

< SYSTEM DESCRIPTION >

| Monitored item | Unit        | Description  | Remarks |
|----------------|-------------|--|---------|
| IDL A/V LEARN  | YET/CMPLT   | <ul style="list-style-type: none"> <li>Displays the condition of Idle Air Volume Learning<br/>YET: Idle air volume learning has not been performed yet.</li> <li>CMPLT: Idle air volume learning has already been performed successfully.</li> </ul>                                       | A       |
| TRVL AFTER MIL | km or mile  | <ul style="list-style-type: none"> <li>Distance traveled while MIL is activated.</li> </ul>  | C       |
| ENG OIL TEMP   | °C or °F    | <ul style="list-style-type: none"> <li>The engine oil temperature (determined by the signal voltage of the engine oil temperature sensor) is displayed.</li> </ul>   | D       |
| VHCL SPEED SE  | km/h or mph | <ul style="list-style-type: none"> <li>The vehicle speed computed from the vehicle speed signal sent from unified meter and combination meter is displayed.</li> </ul>   | E       |
| SET VHCL SPD   | km/h or mph | <ul style="list-style-type: none"> <li>The preset vehicle speed is displayed.</li> </ul>   | F       |
| MAIN SW        | ON/OFF      | <ul style="list-style-type: none"> <li>Indicates [ON/OFF] condition from MAIN switch signal.</li> </ul>  | G       |
| CANCEL SW      | ON/OFF      | <ul style="list-style-type: none"> <li>Indicates [ON/OFF] condition from CANCEL switch signal.</li> </ul>  | H       |
| RESUME/ACC SW  | ON/OFF      | <ul style="list-style-type: none"> <li>Indicates [ON/OFF] condition from RESUME/ACCELERATE switch signal.</li> </ul>   | I       |
| SET SW         | ON/OFF      | <ul style="list-style-type: none"> <li>Indicates [ON/OFF] condition from SET/COAST switch signal.</li> </ul>   | J       |
| BRAKE SW1      | ON/OFF      | <ul style="list-style-type: none"> <li>Indicates [ON/OFF] condition from ASCD brake switch signal.</li> </ul>  | K       |
| BRAKE SW2      | ON/OFF      | <ul style="list-style-type: none"> <li>Indicates [ON/OFF] condition of stop lamp switch signal.</li> </ul>   | L       |
| DIST SW        | ON/OFF      | <ul style="list-style-type: none"> <li>Indicates [ON/OFF] condition from DISTANCE switch signal.</li> </ul>  | M       |
| VHCL SPD CUT   | NON/CUT     | <ul style="list-style-type: none"> <li>Indicates the vehicle cruise condition.<br/>NON: Vehicle speed is maintained at the ASCD set speed.</li> <li>CUT: Vehicle speed decreased to excessively low compared with the ASCD set speed, and ASCD operation is cut off.</li> </ul>            | N       |
| LO SPEED CUT   | NON/CUT     | <ul style="list-style-type: none"> <li>Indicates the vehicle cruise condition.<br/>NON: Vehicle speed is maintained at the ASCD set speed.</li> <li>CUT: Vehicle speed decreased to excessively low, and ASCD operation is cut off.</li> </ul>   | O       |
| AT OD MONITOR  | ON/OFF      | <ul style="list-style-type: none"> <li>Indicates [ON/OFF] condition of A/T O/D according to the input signal from the TCM.</li> </ul>  | P       |
| AT OD CANCEL   | ON/OFF      | <ul style="list-style-type: none"> <li>Indicates [ON/OFF] condition of A/T O/D cancel request signal.</li> </ul>   |         |
| CRUISE LAMP    | ON/OFF      | <ul style="list-style-type: none"> <li>Indicates [ON/OFF] condition of CRUISE indicator determined by the ECM according to the input signals.</li> </ul>   |         |
| SET LAMP       | ON/OFF      | <ul style="list-style-type: none"> <li>Indicates [ON/OFF] condition of SET indicator determined by the ECM according to the input signals.</li> </ul>  |         |
| EXH V/T LEARN  | YET/CMPLT   | <ul style="list-style-type: none"> <li>Display the condition of Exhaust Valve Timing Control Learning<br/>YET: Exhaust Valve Timing Control Learning has not been performed yet.</li> <li>CMPLT: Exhaust Valve Timing Control Learning has already been performed successfully.</li> </ul> |         |

EC

# DIAGNOSIS SYSTEM (ECM)

< SYSTEM DESCRIPTION >

[VK56VD FOR USA AND CANADA]

| Monitored item  | Unit      | Description  | Remarks   |
|-----------------|-----------|--|---|
| FAN DUTY        | %         | <ul style="list-style-type: none"> <li>Indicates a command value for cooling fan. The value is calculated by ECM based on input signals.</li> </ul>  |   |
| AC EVA TEMP     | °C or °F  | <ul style="list-style-type: none"> <li>Indicates A/C evaporator temperature sent from "A/C auto amp."</li> </ul>   |   |
| AC EVA TARGET   | °C or °F  | <ul style="list-style-type: none"> <li>Indicates target A/C evaporator temperature sent from "A/C auto amp."</li> </ul>  |   |
| ALT DUTY        | %         | <ul style="list-style-type: none"> <li>Indicates the duty ratio of the power generation command value. The ratio is calculated by ECM based on the battery current sensor signal.</li> </ul>   |   |
| BAT CUR SEN     | mV        | <ul style="list-style-type: none"> <li>The signal voltage of battery current sensor is displayed.</li> </ul>   |   |
| A/F ADJ-B1      | —         | <ul style="list-style-type: none"> <li>Indicates the correction of a factor stored in ECM. The factor is calculated from the difference between the target air-fuel ratio stored in ECM and the air-fuel ratio calculated from A/F sensor 1 signal.</li> </ul> |   |
| A/F ADJ-B2      |           |  |   |
| TP SEN 1-B2     | V         | <ul style="list-style-type: none"> <li>The throttle position sensor signal voltage is displayed.</li> </ul>  | <ul style="list-style-type: none"> <li>TP SEN 2-B2 signal is converted by ECM internally. Thus, they differs from ECM terminal voltage signal.</li> </ul> |
| TP SEN 2-B2     |           |  |   |
| P/N POSI SW     | ON/OFF    | <ul style="list-style-type: none"> <li>Indicates [ON/OFF] condition from the park/neutral position (PNP) signal.</li> </ul>  |   |
| INT/A TEMP SE   | °C or °F  | <ul style="list-style-type: none"> <li>The intake air temperature (determined by the signal voltage of the intake air temperature sensor) is indicated.</li> </ul>   |   |
| AC PRESS SEN    | V         | <ul style="list-style-type: none"> <li>The signal voltage from the refrigerant pressure sensor is displayed.</li> </ul>  |   |
| FUEL PRESS SEN  | MPa       | <ul style="list-style-type: none"> <li>Indicates the fuel rail pressure computed by ECM according to the input signals</li> </ul>  |   |
| PRESS REG       | %         | <ul style="list-style-type: none"> <li>Displays control duty of the high pressure fuel pump solenoid valve.</li> </ul>   |   |
| FUEL INJB1      | msec      | <ul style="list-style-type: none"> <li>ECM-calculated injection pulse width of the fuel injector on the Bank 1 side.</li> </ul>  |   |
| FUEL INJB2      | msec      | <ul style="list-style-type: none"> <li>ECM-calculated injection pulse width of the fuel injector on the Bank 2 side.</li> </ul>  |   |
| INT/V TIM (B1)  | °CA       | <ul style="list-style-type: none"> <li>Indicates [°CA] of intake camshaft advance angle.</li> </ul>  |   |
| INT/V TIM (B2)  |           |  |   |
| MAP SENSOR      | V         | <ul style="list-style-type: none"> <li>The signal voltage from the manifold absolute pressure (MAP) sensor is displayed.</li> </ul>  |   |
| EVAP LEAK DIAG  | YET/CMPLT | <ul style="list-style-type: none"> <li>Indicates the condition of EVAP leak diagnosis. YET: EVAP leak diagnosis has not been performed yet. CMPLT: EVAP leak diagnosis has been performed successfully.</li> </ul>   |   |
| EVAP DIAG READY | ON/OFF    | <ul style="list-style-type: none"> <li>Indicates the ready condition of EVAP leak diagnosis. ON: Diagnosis has been ready condition. OFF: Diagnosis has not been ready condition.</li> </ul>   |   |
| VVEL LEARN      | YET/DONE  | <ul style="list-style-type: none"> <li>Display the condition of VVEL learning YET: VVEL learning has not been performed yet. DONE: VVEL learning has already been performed successfully.</li> </ul>   |   |

# DIAGNOSIS SYSTEM (ECM)

[VK56VD FOR USA AND CANADA]

## < SYSTEM DESCRIPTION >

| Monitored item       | Unit           | Description   | Remarks |
|----------------------|----------------|---|---------|
| VVEL SEN LEARN-B1    | V              | <ul style="list-style-type: none"> <li>Indicates the VVEL learning value.</li> </ul>  |         |
| VVEL SEN LEARN-B2    |                |   |         |
| VVEL POSITION SEN-B1 | V              | <ul style="list-style-type: none"> <li>The VVEL control shaft position sensor signal voltage is displayed.</li> </ul>   |         |
| VVEL POSITION SEN-B2 |                |   |         |
| VVEL TIM-B1          | deg            | <ul style="list-style-type: none"> <li>Indicates [deg] of VVEL control shaft angle.</li> </ul>  |         |
| VVEL TIM-B2          |                |   |         |
| FPCM                 | HI/MID/LOW/OFF | <ul style="list-style-type: none"> <li>The control condition of the fuel pump control module (FPCM) (determined by ECM according to the input signals) is indicated.</li> </ul> |         |
| BAT TEMP SEN         | V              | <ul style="list-style-type: none"> <li>The signal voltage from the battery temperature sensor is displayed.</li> </ul>  |         |
| THRTL STK CNT B1*    | —              | —   |         |
| THRTL STK CNT B2*    |                |   |         |
| HO2 S2 DIAG2 (B2)    | CMP/INCMP      | <ul style="list-style-type: none"> <li>These items are displayed but are not applicable to this model.</li> </ul>   |         |
| HO2 S2 DIAG2 (B1)    | CMP/INCMP      |   |         |
| FUEL INJ TIMG        | deg            | <ul style="list-style-type: none"> <li>Indicates the fuel injection timing computed by ECM according to the input signals.</li> </ul>   |         |
| H/P FUEL PUMP DEG    | deg            | <ul style="list-style-type: none"> <li>Displays ECM-calculated fuel discharge position of the high pressure fuel pump.</li> </ul>   |         |
| FUEL PRES SEN V      | mV             | <ul style="list-style-type: none"> <li>The signal voltage of FRP sensor is displayed.</li> </ul>  |         |
| L/FUEL PRES SEN      | MPa            | <ul style="list-style-type: none"> <li>Displays a pressure value calculated from a low fuel pressure sensor voltage.</li> </ul>   |         |
| L/FUEL PRES SEN V    | mV             | <ul style="list-style-type: none"> <li>The signal voltage of low fuel pressure sensor is displayed.</li> </ul>  |         |
| EOP SENSOR           | mV             | <ul style="list-style-type: none"> <li>The signal voltage of EOP sensor is displayed.</li> </ul>  |         |
| ECM TEMP 1           | °C or °F       | <ul style="list-style-type: none"> <li>Displays a temperature calculated from a signal of ECM temperature sensor 1.</li> </ul>  |         |
| ECM TEMP 2           | °C or °F       | <ul style="list-style-type: none"> <li>Displays a temperature calculated from a signal of ECM temperature sensor 2.</li> </ul>  |         |
| FUEL PUMP DUTY       | %              | <ul style="list-style-type: none"> <li>The control condition of the fuel pump control module (FPCM) (determined by ECM according to the input signals) is indicated.</li> </ul> |         |

\*: The item is indicated, but not used.

### NOTE:

Any monitored item that does not match the vehicle being diagnosed is deleted from the display automatically.

## ACTIVE TEST MODE

Test Item

# DIAGNOSIS SYSTEM (ECM)

< SYSTEM DESCRIPTION >

[VK56VD FOR USA AND CANADA]

| TEST ITEM            | CONDITION   | JUDGMENT   | CHECK ITEM (REMEDY)   |
|----------------------|---|--|---|
| VENT CONTROL/V       | <ul style="list-style-type: none"> <li>Ignition switch: ON (Engine stopped)</li> <li>Turn solenoid valve ON and OFF with the CONSULT and listen to operating sound.</li> </ul>  | Solenoid valve makes an operating sound.               | <ul style="list-style-type: none"> <li>Harness and connectors</li> <li>Solenoid valve</li> </ul>  |
| ENG COOLANT TEMP     | <ul style="list-style-type: none"> <li>Engine: Return to the original non-standard condition</li> <li>Change the engine coolant temperature using CONSULT.</li> </ul>   | If malfunctioning symptom disappears, see CHECK ITEM.  | <ul style="list-style-type: none"> <li>Harness and connectors</li> <li>Engine coolant temperature sensor</li> <li>Fuel injector</li> </ul>  |
| FUEL INJECTION       | <ul style="list-style-type: none"> <li>Engine: Return to the original non-standard condition</li> <li>Change the amount of fuel injection using CONSULT.</li> </ul>   | If malfunctioning symptom disappears, see CHECK ITEM.  | <ul style="list-style-type: none"> <li>Harness and connectors</li> <li>Fuel injector</li> <li>Air fuel ratio (A/F) sensor 1</li> </ul>  |
| FUEL/T TEMP SEN      | <ul style="list-style-type: none"> <li>Change the fuel tank temperature using CONSULT.</li> </ul>   |  |   |
| PURG VOL CONT/V      | <ul style="list-style-type: none"> <li>Engine: After warming up, run engine at 1,500 rpm.</li> <li>Change the EVAP canister purge volume control solenoid valve opening percent using CONSULT.</li> </ul>               | Engine speed changes according to the opening percent. | <ul style="list-style-type: none"> <li>Harness and connectors</li> <li>Solenoid valve</li> </ul>  |
| FAN DUTY CONTROL*    | <ul style="list-style-type: none"> <li>Ignition switch: ON</li> <li>Change duty ratio using CONSULT.</li> </ul>   | Cooling fan speed changes.                             | <ul style="list-style-type: none"> <li>Harness and connectors</li> <li>Cooling fan motor</li> <li>Cooling fan relay</li> <li>Cooling fan control module</li> <li>IPDM E/R</li> </ul>      |
| ALTERNATOR DUTY      | <ul style="list-style-type: none"> <li>Engine: Idle</li> <li>Change duty ratio using CONSULT.</li> </ul>  | Battery voltage changes.                               | <ul style="list-style-type: none"> <li>Harness and connectors</li> <li>IPDM E/R</li> <li>Alternator</li> </ul>  |
| EXH V/T ASSIGN ANGLE | <ul style="list-style-type: none"> <li>Engine: Return to the original non-standard condition</li> <li>Change exhaust valve timing using CONSULT.</li> </ul>   | If malfunctioning symptom disappears, see CHECK ITEM.  | <ul style="list-style-type: none"> <li>Harness and connectors</li> <li>Exhaust valve timing control magnet retarder</li> </ul>  |
| POWER BALANCE        | <ul style="list-style-type: none"> <li>Engine: After warming up, idle the engine.</li> <li>A/C switch OFF</li> <li>Selector lever: P or N</li> <li>Cut off each injector signal one at a time using CONSULT.</li> </ul> | Engine runs rough or stops.                            | <ul style="list-style-type: none"> <li>Harness and connectors</li> <li>Compression</li> <li>Fuel injector</li> <li>Power transistor</li> <li>Spark plug</li> <li>Ignition coil</li> </ul> |
| INT V/T ASSIGN ANGLE | <ul style="list-style-type: none"> <li>Engine: Return to the original non-standard condition</li> <li>Change intake valve timing using CONSULT.</li> </ul>  | If malfunctioning symptom disappears, see CHECK ITEM.  | <ul style="list-style-type: none"> <li>Harness and connectors</li> <li>Intake valve timing control solenoid valve</li> </ul>  |
| IGNITION TIMING      | <ul style="list-style-type: none"> <li>Engine: Return to the original non-standard condition</li> <li>Timing light: Set</li> <li>Retard the ignition timing using CONSULT.</li> </ul>                                   | If malfunctioning symptom disappears, see CHECK ITEM.  | <ul style="list-style-type: none"> <li>Perform Idle Air Volume Learning.</li> </ul>   |
| FPCM                 | <ul style="list-style-type: none"> <li>Engine: Return to the original trouble condition</li> <li>Select "LOW", "MID" and "HI" with CONSULT.</li> </ul>  | Fuel pump speed changes or stops.                      | <ul style="list-style-type: none"> <li>Harness and connectors</li> <li>Fuel pump control module (FPCM)</li> </ul>   |

\*: Leaving cooling fan OFF with CONSULT while engine is running may cause the engine to overheat.

## DTC & SRT CONFIRMATION MODE

### SRT STATUS Mode

- For items whose SRT codes are set, "CMPLT" is displayed on the CONSULT screen; for items whose SRT codes are not set, "INCMP" is displayed.

# DIAGNOSIS SYSTEM (ECM)

[VK56VD FOR USA AND CANADA]

## < SYSTEM DESCRIPTION >

- “SRT STATUS” provides the presence or absence of permanent DTCs stored in ECM memory.

### PERMANENT DTC STATUS Mode

How to display permanent DTC status

1. Turn ignition switch OFF and wait at least 10 seconds.
2. Turn ignition switch ON.
3. Turn ignition switch OFF and wait at least 10 seconds.
4. Turn ignition switch ON.
5. Select “PERMANENT DTC STATUS” in “DTC & SRT CONFIRMATION” mode with CONSULT.

#### NOTE:

Permanent DTCs stored in ECM memory are displayed on the CONSULT screen to show if a driving pattern required for erasing permanent DTCs is complete (CMPLT) or incomplete (INCMP).

#### CAUTION:

Since the “PERMANENT DTC STATUS” screen displays the previous trip information, repeat the following twice to update the information: “Ignition switch OFF”, “Wait for more than 10 seconds” and “Ignition switch ON”.

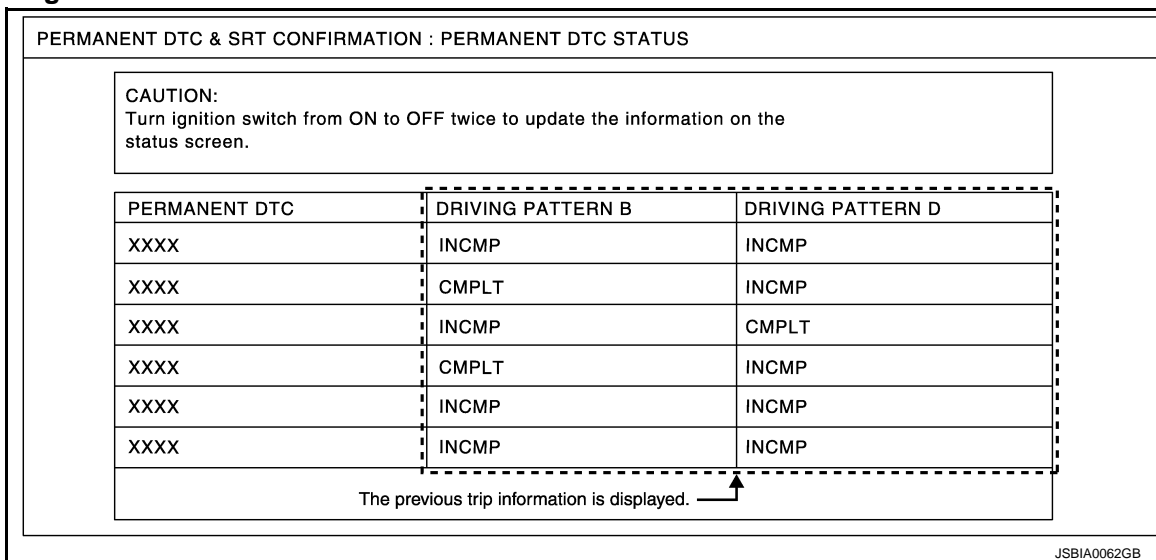

#### NOTE:

This mode is not used in regions that permanent DTCs are not regulated by law.

### SRT WORK SUPPORT Mode

This mode enables a technician to drive a vehicle to set the SRT while monitoring the SRT status.

### PERMANENT DTC WORK SUPPORT Mode

This mode enables a technician to drive a vehicle to complete the driving pattern that is required for erasing permanent DTC.

#### NOTE:

This mode is not used in regions that permanent DTCs are not regulated by law.

### DTC WORK SUPPORT Mode

| Test mode | Test item                 | Corresponding DTC No. | Reference page                       |
|-----------|---------------------------|-----------------------|--------------------------------------|
| HO2S2     | HO2S2 (B1) P1146          | P0138                 | <a href="#">EC-1250, "DTC Logic"</a> |
|           | HO2S2 (B1) P1147          | P0137                 | <a href="#">EC-1244, "DTC Logic"</a> |
|           | HO2S2 (B1) P0139          | P0139                 | <a href="#">EC-1258, "DTC Logic"</a> |
|           | HO2S2 (B2) P1166          | P0158                 | <a href="#">EC-1250, "DTC Logic"</a> |
|           | HO2S2 (B2) P1167          | P0157                 | <a href="#">EC-1244, "DTC Logic"</a> |
|           | HO2S2 (B2) P0159          | P0159                 | <a href="#">EC-1258, "DTC Logic"</a> |
| A/F SEN1  | A/F SEN1 (B1) P1278/P1279 | P0133                 | <a href="#">EC-1239, "DTC Logic"</a> |
|           | A/F SEN1 (B1) P1276       | P0130                 | <a href="#">EC-1229, "DTC Logic"</a> |
|           | A/F SEN1 (B2) P1288/P1289 | P0153                 | <a href="#">EC-1239, "DTC Logic"</a> |
|           | A/F SEN1 (B2) P1286       | P0150                 | <a href="#">EC-1229, "DTC Logic"</a> |

# DIAGNOSIS SYSTEM (ECM)

[VK56VD FOR USA AND CANADA]

< SYSTEM DESCRIPTION >

| Test mode          | Test item                 | Corresponding DTC No. | Reference page                       |
|--------------------|---------------------------|-----------------------|--------------------------------------|
| EVAPORATIVE SYSTEM | EVP V/S LEAK P0456/P1456* | P0456                 | <a href="#">EC-1355. "DTC Logic"</a> |
|                    | PURG VOL CN/V P1444       | P0443                 | <a href="#">EC-1324. "DTC Logic"</a> |
|                    | PURG FLOW P0441           | P0441                 | <a href="#">EC-1319. "DTC Logic"</a> |

\*: DTC P1456 does not apply to Y51 models but appears in DTC Work Support Mode screens.

# ECU DIAGNOSIS INFORMATION

## ECM

### Reference Value

INFOID:000000007187416

### VALUES ON THE DIAGNOSIS TOOL

#### NOTE:

- Specification data are reference values.
- Specification data are output/input values which are detected or supplied by the ECM at the connector.
  - \* Specification data may not be directly related to their components signals/values/operations.
    - i.e. Adjust ignition timing with a timing light before monitoring IGN TIMING, because the monitor may show the specification data in spite of the ignition timing not being adjusted to the specification data. This IGN TIMING monitors the data calculated by the ECM according to the signals input from the camshaft position sensor and other ignition timing related sensors.

#### CONSULT MONITOR ITEM

| Monitor Item    | Condition  |                                       | Values/Status                                      |
|-----------------|--|---------------------------------------|--|
| ENG SPEED       | • Run engine and compare CONSULT value with the tachometer indication.   |                                       | Almost the same speed as the tachometer indication |
| MAS A/F SE-B1   | See <a href="#">EC-1142</a> , "Description".   |                                       |  |
| MAS A/F SE-B2   | See <a href="#">EC-1142</a> , "Description".   |                                       |  |
| B/FUEL SCHDL    | See <a href="#">EC-1142</a> , "Description".   |                                       |  |
| A/F ALPHA-B1    | See <a href="#">EC-1142</a> , "Description".   |                                       |  |
| A/F ALPHA-B2    | See <a href="#">EC-1142</a> , "Description".   |                                       |  |
| COOLAN TEMP/S   | • Ignition switch: ON  |                                       | Indicates engine coolant temperature               |
| A/F SEN1 (B1)   | • Engine: After warming up   | Maintaining engine speed at 2,000 rpm | Fluctuates around 1.5 V                            |
| A/F SEN1 (B2)   | • Engine: After warming up   | Maintaining engine speed at 2,000 rpm | Fluctuates around 1.5 V                            |
| HO2S2 (B1)      | <ul style="list-style-type: none"> <li>• Revving engine from idle up to 3,000 rpm quickly after the following conditions are met.</li> <li>- Engine: After warming up</li> <li>- After keeping engine speed between 3,500 and 4,000 rpm for 1 minute and at idle for 1 minute under no load</li> </ul> |                                       | 0 - 0.3 V ↔ Approx. 0.6 - 1.0 V                    |
| HO2S2 (B2)      | <ul style="list-style-type: none"> <li>• Revving engine from idle up to 3,000 rpm quickly after the following conditions are met.</li> <li>- Engine: After warming up</li> <li>- After keeping engine speed between 3,500 and 4,000 rpm for 1 minute and at idle for 1 minute under no load</li> </ul> |                                       | 0 - 0.3 V ↔ Approx. 0.6 - 1.0 V                    |
| HO2S2 MNTR (B1) | <ul style="list-style-type: none"> <li>• Revving engine from idle up to 3,000 rpm quickly after the following conditions are met.</li> <li>- Engine: After warming up</li> <li>- After keeping engine speed between 3,500 and 4,000 rpm for 1 minute and at idle for 1 minute under no load</li> </ul> |                                       | LEAN ↔ RICH  |
| HO2S2 MNTR (B2) | <ul style="list-style-type: none"> <li>• Revving engine from idle up to 3,000 rpm quickly after the following conditions are met.</li> <li>- Engine: After warming up</li> <li>- After keeping engine speed between 3,500 and 4,000 rpm for 1 minute and at idle for 1 minute under no load</li> </ul> |                                       | LEAN ↔ RICH  |
| VHCL SPEED SE   | • Turn drive wheels and compare CONSULT value with the speedometer indication.   |                                       | Almost the same speed as speedometer indication    |
| BATTERY VOLT    | • Ignition switch: ON (Engine stopped)   |                                       | 11 - 14 V  |
| ACCEL SEN 1     | • Ignition switch: ON (Engine stopped)   | Accelerator pedal: Fully released     | 0.45 - 1.0 V                                       |
|                 |  | Accelerator pedal: Fully depressed    | 4.4 - 4.8 V  |
| ACCEL SEN 2*1   | • Ignition switch: ON (Engine stopped)   | Accelerator pedal: Fully released     | 0.45 - 1.0 V                                       |
|                 |  | Accelerator pedal: Fully depressed    | 4.3 - 4.8 V  |

# ECM

< ECU DIAGNOSIS INFORMATION >

[VK56VD FOR USA AND CANADA]

| Monitor Item  | Condition   |  | Values/Status   |
|---------------|---|--|---|
| TP SEN 1-B1   | <ul style="list-style-type: none"> <li>Ignition switch: ON (Engine stopped)</li> <li>Selector lever: D position</li> </ul>                                    | Accelerator pedal: Fully released                                    | More than 0.36 V  |
|               |   | Accelerator pedal: Fully depressed                                   | Less than 4.75 V  |
| TP SEN 2-B1*1 | <ul style="list-style-type: none"> <li>Ignition switch: ON (Engine stopped)</li> <li>Selector lever: D position</li> </ul>                                    | Accelerator pedal: Fully released                                    | More than 0.36 V  |
|               |   | Accelerator pedal: Fully depressed                                   | Less than 4.75 V  |
| FUEL T/TMP SE | <ul style="list-style-type: none"> <li>Ignition switch: ON</li> </ul>   |  | Indicates fuel tank temperature                                 |
| EVAP SYS PRES | <ul style="list-style-type: none"> <li>Ignition switch: ON</li> </ul>   |  | Approx. 1.8 - 4.8 V   |
| FUEL LEVEL SE | <ul style="list-style-type: none"> <li>Ignition switch: ON</li> </ul>   |  | Depending on fuel level of fuel tank                            |
| START SIGNAL  | <ul style="list-style-type: none"> <li>Ignition switch: ON → START → ON</li> </ul>  |  | OFF → ON → OFF  |
| CLSD THL POS  | <ul style="list-style-type: none"> <li>Ignition switch: ON (Engine stopped)</li> </ul>  | Accelerator pedal: Fully released                                    | ON  |
|               |   | Accelerator pedal: Slightly depressed                                | OFF   |
| AIR COND SIG  | <ul style="list-style-type: none"> <li>Engine: After warming up, idle the engine</li> </ul>   | Air conditioner switch: OFF  | OFF   |
|               |   | Air conditioner switch: ON (Compressor operates.)                    | ON  |
| PW/ST SIGNAL  | <ul style="list-style-type: none"> <li>Engine: After warming up, idle the engine</li> </ul>   | Steering wheel: Not being turned                                     | OFF   |
|               |   | Steering wheel: Being turned   | ON  |
| LOAD SIGNAL   | <ul style="list-style-type: none"> <li>Ignition switch: ON</li> </ul>   | Rear window defogger switch: ON and/or Lighting switch: 2nd position | ON  |
|               |   | Rear window defogger switch and lighting switch: OFF                 | OFF   |
| IGNITION SW   | <ul style="list-style-type: none"> <li>Ignition switch: ON → OFF → ON</li> </ul>  |  | ON → OFF → ON   |
| HEATER FAN SW | <ul style="list-style-type: none"> <li>Engine: After warming up, idle the engine</li> </ul>   | Blower fan switch: ON  | ON  |
|               |   | Blower fan switch: OFF   | OFF   |
| BRAKE SW      | <ul style="list-style-type: none"> <li>Ignition switch: ON</li> </ul>   | Brake pedal: Fully released  | OFF   |
|               |   | Brake pedal: Slightly depressed                                      | ON  |
| INJ PULSE-B1  | <ul style="list-style-type: none"> <li>Engine: After warming up</li> <li>Selector lever: P or N position</li> <li>A/C switch: OFF</li> <li>No load</li> </ul> | Idle   | 2.0 - 3.0 msec  |
|               |   | 2,000 rpm  | 1.9 - 2.9 msec  |
| INJ PULSE-B2  | <ul style="list-style-type: none"> <li>Engine: After warming up</li> <li>Selector lever: P or N position</li> <li>A/C switch: OFF</li> <li>No load</li> </ul> | Idle   | 2.0 - 3.0 msec  |
|               |   | 2,000 rpm  | 1.9 - 2.9 msec  |
| IGN TIMING    | <ul style="list-style-type: none"> <li>Engine: After warming up</li> <li>Selector lever: P or N position</li> <li>A/C switch: OFF</li> <li>No load</li> </ul> | Idle   | 1 - 4°BTDC  |
|               |   | 2,000 rpm  | 25 - 45°BTDC  |
| COMBUSTION    |   | —  | These items are displayed but are not applicable to this model. |
| CAL/LD VALUE  | <ul style="list-style-type: none"> <li>Engine: After warming up</li> <li>Selector lever: P or N position</li> <li>A/C switch: OFF</li> <li>No load</li> </ul> | Idle   | 5 - 35%   |
|               |   | 2,500 rpm  | 5 - 35%   |
| MASS AIRFLOW  | <ul style="list-style-type: none"> <li>Engine: After warming up</li> <li>Selector lever: P or N position</li> <li>A/C switch: OFF</li> <li>No load</li> </ul> | Idle   | 2.0 - 6.0 g/s   |
|               |   | 2,500 rpm  | 7.0 - 20.0 g/s  |



# ECM

< ECU DIAGNOSIS INFORMATION >

[VK56VD FOR USA AND CANADA]

| Monitor Item    | Condition   | Values/Status                                       |
|-----------------|---|---|
| PURG VOL C/V    | <ul style="list-style-type: none"> <li>Engine: After warming up</li> <li>Selector lever: P or N position</li> <li>A/C switch: OFF</li> <li>No load</li> </ul> Idle<br>(Accelerator pedal: Not depressed even slightly, after engine starting.)                                  | 0%  |
|                 | 2,000 rpm   | 5%  |
| EXH/V TIM B1    | <ul style="list-style-type: none"> <li>Engine: After warming up</li> <li>Selector lever: P or N position</li> <li>A/C switch: OFF</li> <li>No load</li> </ul> Idle  | -5° - 5°C   |
|                 | Around 2,500 rpm while the engine speed is rising   | Approx. 0 - 30°C                                    |
| EXH/V TIM B2    | <ul style="list-style-type: none"> <li>Engine: After warming up</li> <li>Selector lever: P or N position</li> <li>A/C switch: OFF</li> <li>No load</li> </ul> Idle  | -5 - 5°C  |
|                 | Around 2,500 rpm while the engine speed is rising   | Approx. 0 - 30°C                                    |
| INT/V SOL (B1)  | <ul style="list-style-type: none"> <li>Engine: After warming up</li> <li>Selector lever: P or N position</li> <li>A/C switch: OFF</li> <li>No load</li> </ul> Idle  | 0 - 2%  |
|                 | 2,000 rpm   | Approx. 0 - 50%                                     |
| INT/V SOL (B2)  | <ul style="list-style-type: none"> <li>Engine: After warming up</li> <li>Selector lever: P or N position</li> <li>A/C switch: OFF</li> <li>No load</li> </ul> Idle  | 0 - 2%  |
|                 | 2,000 rpm   | Approx. 0 - 50%                                     |
| AIR COND RLY    | <ul style="list-style-type: none"> <li>Engine: After warming up, idle the engine</li> </ul> A/C switch: OFF   | OFF   |
|                 | A/C switch: ON<br>(Compressor operates)   | ON  |
| VENT CONT/V     | <ul style="list-style-type: none"> <li>Ignition switch: ON</li> </ul>   | OFF   |
| THRTL RELAY     | <ul style="list-style-type: none"> <li>Ignition switch: ON</li> </ul>   | ON  |
| A/F S1 HTR (B1) | <ul style="list-style-type: none"> <li>Engine: After warming up, idle the engine<br/>(More than 140 seconds after starting engine)</li> </ul>   | 4 - 100%  |
| A/F S1 HTR (B2) | <ul style="list-style-type: none"> <li>Engine: After warming up, idle the engine<br/>(More than 140 seconds after starting engine)</li> </ul>   | 4 - 100%  |
| HO2S2 HTR (B1)  | <ul style="list-style-type: none"> <li>Engine speed: Below 3,600 rpm after the following conditions are met.</li> <li>- Engine: After warming up</li> <li>- Keeping the engine speed between 3,500 and 4,000 rpm for 1 minute and at idle for 1 minute under no load</li> </ul> | ON  |
|                 | <ul style="list-style-type: none"> <li>Engine speed: Above 3,600 rpm</li> </ul>   | OFF   |
| HO2S2 HTR (B2)  | <ul style="list-style-type: none"> <li>Engine speed: Below 3,600 rpm after the following conditions are met.</li> <li>- Engine: After warming up</li> <li>- Keeping the engine speed between 3,500 and 4,000 rpm for 1 minute and at idle for 1 minute under no load</li> </ul> | ON  |
|                 | <ul style="list-style-type: none"> <li>Engine speed: Above 3,600 rpm</li> </ul>   | OFF   |
| ALT DUTY SIG    | <ul style="list-style-type: none"> <li>Power generation voltage variable control: Operating</li> </ul>  | ON  |
|                 | <ul style="list-style-type: none"> <li>Power generation voltage variable control: Not operating</li> </ul>  | OFF   |
| I/P PULLY SPD   | <ul style="list-style-type: none"> <li>Vehicle speed: More than 20 km/h (12 MPH)</li> </ul>   | Almost the same speed as the tachometer indication  |
| VEHICLE SPEED   | <ul style="list-style-type: none"> <li>Turn drive wheels and compare CONSULT value with the speedometer indication.</li> </ul>  | Almost the same speed as the speedometer indication |
| IDL A/V LEARN   | <ul style="list-style-type: none"> <li>Engine: Running</li> </ul> Idle air volume learning has not been performed yet.  | YET   |
|                 | Idle air volume learning has already been performed successfully.   | CMPLT   |
| TRVL AFTER MIL  | <ul style="list-style-type: none"> <li>Ignition switch: ON</li> </ul> Vehicle has traveled after MIL has illuminated.   | 0 - 65,535 km<br>(0 - 40,723 miles)                 |
| ENG OIL TEMP    | <ul style="list-style-type: none"> <li>Engine: After warming up</li> </ul>  | More than 70°C (158°F)                              |
| VHCL SPEED SE   | <ul style="list-style-type: none"> <li>Turn drive wheels and compare CONSULT value with the speedometer indication.</li> </ul>  | Almost the same speed as the speedometer indication |

A

EC

C

D

E

F

G

H

I

J

K

L

M

N

O

P

# ECM

< ECU DIAGNOSIS INFORMATION >

[VK56VD FOR USA AND CANADA]

| Monitor Item                         | Condition   |   | Values/Status   |
|--------------------------------------|---|---|---|
| SET VHCL SPD                         | • Engine: Running   | ASCD: Operating   | The preset vehicle speed is displayed                                 |
| MAIN SW                              | • Ignition switch: ON   | MAIN switch: Pressed  | ON  |
|                                      |   | MAIN switch: Released   | OFF   |
| CANCEL SW                            | • Ignition switch: ON   | CANCEL switch: Pressed  | ON  |
|                                      |   | CANCEL switch: Released   | OFF   |
| RESUME/ACC SW                        | • Ignition switch: ON   | RESUME/ACCELERATE switch: Pressed                                 | ON  |
|                                      |   | RESUME/ACCELERATE switch: Released                                | OFF   |
| SET SW                               | • Ignition switch: ON   | SET/COAST switch: Pressed   | ON  |
|                                      |   | SET/COAST switch: Released  | OFF   |
| BRAKE SW1<br>(ASCD/ICC brake switch) | • Ignition switch: ON   | Brake pedal: Fully released                                       | ON  |
|                                      |   | Brake pedal: Slightly depressed                                   | OFF   |
| BRAKE SW2<br>(Stop lamp switch)      | • Ignition switch: ON   | Brake pedal: Fully released                                       | OFF   |
|                                      |   | Brake pedal: Slightly depressed                                   | ON  |
| DIST SW                              | • Ignition switch: ON   | DISTANCE switch: Pressed  | ON  |
|                                      |   | DISTANCE switch: Released   | OFF   |
| VHCL SPD CUT                         | • Ignition switch: ON   |   | NON   |
| LO SPEED CUT                         | • Ignition switch: ON   |   | NON   |
| AT OD MONITOR                        | • Ignition switch: ON   |   | OFF   |
| AT OD CANCEL                         | • Ignition switch: ON   |   | OFF   |
| CRUISE LAMP                          | • Ignition switch: ON   | MAIN switch: Pressed at the 1st time → at the 2nd time            | ON → OFF  |
| SET LAMP                             | • MAIN switch: ON<br>• When vehicle speed is between 40 km/h (25 MPH) and 144 km/h (89 MPH)                               | ASCD: Operating   | ON  |
|                                      |   | ASCD: Not operating   | OFF   |
| EXH V/T LEARN                        | • Engine: Running   | Exhaust Valve Timing Control Learning has not been performed yet. | YET   |
|                                      |   | Exhaust Valve Timing Control Learning has not been performed yet. | CMPLT   |
| FAN DUTY                             | • Engine: Running   |   | 0 - 100%  |
| AC EVA TEMP                          | • Engine: Running   |   | Indicates A/C evaporator temperature sent from "A/C auto amp."        |
| AC EVA TARGET                        | • Engine: Running   |   | Indicates target A/C evaporator temperature sent from "A/C auto amp." |
| ALT DUTY                             | • Engine: Idle  |   | 0 - 80%   |
| BAT CUR SEN                          | • Engine speed: Idle<br>• Battery: Fully charged*2<br>• Selector lever: P or N position<br>• A/C switch: OFF<br>• No load |   | Approx. 2,600 - 3,500 mV  |
| A/F ADJ-B1                           | • Engine: Running   |   | -0.330 - 0.330  |
| A/F ADJ-B2                           | • Engine: Running   |   | -0.330 - 0.330  |
| TP SEN 1-B2                          | • Ignition switch: ON (Engine stopped)<br>• Selector lever: D position  | Accelerator pedal: Fully released                                 | More than 0.36 V  |
|                                      |   | Accelerator pedal: Fully depressed                                | Less than 4.75 V  |

# ECM

< ECU DIAGNOSIS INFORMATION >

[VK56VD FOR USA AND CANADA]

| Monitor Item         | Condition   |  | Values/Status   |
|----------------------|---|--|---|
| TP SEN 2-B2*1        | <ul style="list-style-type: none"> <li>Ignition switch: ON (Engine stopped)</li> <li>Selector lever: D position</li> </ul>  | Accelerator pedal: Fully released                      | More than 0.36 V                                      |
|                      |   | Accelerator pedal: Fully depressed                     | Less than 4.75 V                                      |
| P/N POSI SW          | <ul style="list-style-type: none"> <li>Ignition switch: ON</li> </ul>   | Selector lever: P or N                                 | ON  |
|                      |   | Selector lever: Except above position                  | OFF   |
| INT/A TEMP SE        | <ul style="list-style-type: none"> <li>Ignition switch: ON</li> </ul>   |  | Indicates intake air temperature                      |
| AC PRESS SEN         | <ul style="list-style-type: none"> <li>Engine: Idle</li> <li>Both A/C switch and blower fan switch: ON (Compressor operates)</li> </ul>                                   |  | 1.0 - 4.0 V   |
| FUEL PRES SEN        | <ul style="list-style-type: none"> <li>Engine: After warming up</li> <li>Selector lever: P or N position</li> <li>A/C switch: OFF</li> <li>No load</li> </ul>             | Idle   | Approx. 2.74 MPa                                      |
|                      |   | 2,000 rpm  | Approx. 3.0 MPa                                       |
| PRESS REG            | <ul style="list-style-type: none"> <li>Engine: After warming up</li> <li>Selector lever: P or N position</li> <li>A/C switch: OFF</li> <li>No load</li> </ul>             | Idle   | Approx. 82.5%   |
|                      |   | 2,000 rpm  | Approx. 90.0%   |
| FUEL INJ B1          | <ul style="list-style-type: none"> <li>Engine: After warming up</li> <li>Selector lever: P or N position</li> <li>A/C switch: OFF</li> <li>No load</li> </ul>             | Idle   | Approx. 1.4 msec                                      |
|                      |   | 2,000 rpm  | Approx. 1.0 msec                                      |
| FUEL INJ B2          | <ul style="list-style-type: none"> <li>Engine: After warming up</li> <li>Selector lever: P or N position</li> <li>A/C switch: OFF</li> <li>No load</li> </ul>             | Idle   | Approx. 1.4 msec                                      |
|                      |   | 2,000 rpm  | Approx. 1.0 msec                                      |
| INT/V TIM (B1)       | <ul style="list-style-type: none"> <li>Engine: After warming up</li> <li>Selector lever: P or N position</li> <li>A/C switch: OFF</li> <li>No load</li> </ul>             | Idle   | -5 - 5°C  |
|                      |   | 2,000 rpm  | Approx. 0 - 30°C                                      |
| INT/V TIM (B2)       | <ul style="list-style-type: none"> <li>Engine: After warming up</li> <li>Selector lever: P or N position</li> <li>A/C switch: OFF</li> <li>No load</li> </ul>             | Idle   | -5 - 5°C  |
|                      |   | 2,000 rpm  | Approx. 0 - 30°C                                      |
| VVEL LEARN           | <ul style="list-style-type: none"> <li>Ignition switch: OFF → ON (After warming up)</li> </ul>  | VVEL learning has not been performed yet.              | YET   |
|                      |   | VVEL learning has already been performed successfully. | DONE  |
| MAP SENSOR           | <ul style="list-style-type: none"> <li>Engine: After warming up</li> <li>Selector lever: P or N position</li> <li>A/C switch: OFF</li> <li>No load</li> </ul>             | Idle   | Approx. 1.0 V   |
|                      |   | 2,000 rpm  | Approx. 1.35 V  |
| EVAP LEAK DIAG       | <ul style="list-style-type: none"> <li>Ignition switch: ON</li> </ul>   |  | Indicates the condition of EVAP leak diagnosis.       |
| EVAP DIAG READY      | <ul style="list-style-type: none"> <li>Ignition switch: ON</li> </ul>   |  | Indicates the ready condition of EVAP leak diagnosis. |
| VVEL SEN LEARN-B1    | <ul style="list-style-type: none"> <li>VVEL learning has already been performed successfully</li> </ul>   |  | Approx. 0.30 - 0.80 V                                 |
| VVEL SEN LEARN-B2    | <ul style="list-style-type: none"> <li>VVEL learning has already been performed successfully</li> </ul>   |  | Approx. 0.30 - 0.80 V                                 |
| VVEL POSITION SEN-B1 | <ul style="list-style-type: none"> <li>Engine: After warming up</li> <li>Selector lever: P or N position</li> <li>A/C switch: OFF</li> <li>No load</li> </ul>             | Idle   | Approx. 0.25 - 1.50 V                                 |
|                      |   | When revving engine up to 2,000 rpm quickly            | Approx. 0.25 - 4.75 V                                 |
| VVEL POSITION SEN-B2 | <ul style="list-style-type: none"> <li>Engine: After warming up</li> <li>Selector lever: P or N position</li> <li>Air conditioner switch: OFF</li> <li>No load</li> </ul> | Idle   | Approx. 0.25 - 1.50 V                                 |
|                      |   | When revving engine up to 2,000 rpm quickly            | Approx. 0.25 - 4.75 V                                 |

A

EC

C

D

E

F

G

H

I

J

K

L

M

N

O

P

# ECM

< ECU DIAGNOSIS INFORMATION >

[VK56VD FOR USA AND CANADA]

| Monitor Item      | Condition  | Values/Status   |  |
|-------------------|--|---|--|
| VVEL TIM-B1       | <ul style="list-style-type: none"> <li>• Engine: After warming up</li> <li>• Selector lever: P or N position</li> <li>• A/C switch: OFF</li> <li>• No load</li> </ul>        | Idle<br>Approx. 0 - 23 deg  |  |
|                   | When revving engine up to 2,000 rpm quickly  | Approx. 0 - 90 deg  |  |
| VVEL TIM-B2       | <ul style="list-style-type: none"> <li>• Engine: After warming up</li> <li>• Selector lever: P or N position</li> <li>• A/C switch: OFF</li> <li>• No load</li> </ul>        | Idle<br>Approx. 0 - 23 deg  |  |
|                   | When revving engine up to 2,000 rpm quickly  | Approx. 0 - 90 deg  |  |
| FPCM              | <ul style="list-style-type: none"> <li>• Engine: After warming up</li> <li>• Selector lever: P or N position</li> <li>• A/C switch: OFF</li> <li>• No load</li> </ul>        | <ul style="list-style-type: none"> <li>• Engine: Cranking</li> </ul>  | HI   |
|                   |  | <ul style="list-style-type: none"> <li>• Revving engine from idle to 4,000 rpm quickly</li> </ul>                             | MID  |
|                   |  | <ul style="list-style-type: none"> <li>• Engine: Idle</li> <li>• Engine coolant temperature: More than 10°C (50°F)</li> </ul> | LOW  |
| BAT TEMP SEN      | <ul style="list-style-type: none"> <li>• Engine: After warming up</li> <li>• Selector lever: P or N position</li> <li>• A/C switch: OFF</li> <li>• No load</li> </ul>        | Idle  | Indicates the temperature around the battery.        |
| THRTL STK CNT B1  | Not used.  |   | —  |
| THRTL STK CNT B2  |  |   |  |
| HO2 S2 DIAG2 (B2) | <ul style="list-style-type: none"> <li>• DTC P0139 self-diagnosis (slow response) is incomplete.</li> <li>• DTC P0139 self-diagnosis (slow response) is complete.</li> </ul> |   | IMCMP  |
|                   |  |   | CMPLT  |
| HO2 S2 DIAG2 (B1) | <ul style="list-style-type: none"> <li>• DTC P0139 self-diagnosis (slow response) is incomplete.</li> <li>• DTC P0139 self-diagnosis (slow response) is complete.</li> </ul> |   | IMCMP  |
|                   |  |   | CMPLT  |
| FUEL INJ TIMG     | <ul style="list-style-type: none"> <li>• Engine: After warming up</li> <li>• Selector lever: P or N position</li> <li>• A/C switch: OFF</li> <li>• No load</li> </ul>        | Idle  | Approx. 16 deg                                       |
|                   |  | 2,000 rpm   | Approx. -170 deg                                     |
| H/P FUEL PUMP DEG | <ul style="list-style-type: none"> <li>• Engine: After warming up</li> <li>• Selector lever: P or N position</li> <li>• A/C switch: OFF</li> <li>• No load</li> </ul>        | Idle  | Approx. 211.0 deg                                    |
|                   |  | 2,000 rpm   | Approx. 206.0 deg                                    |
| FUEL PRES SEN V   | <ul style="list-style-type: none"> <li>• Engine: After warming up</li> <li>• Selector lever: P or N position</li> <li>• A/C switch: OFF</li> <li>• No load</li> </ul>        | Idle  | Approx. 820 – 1,220 mV                               |
|                   |  | Revving engine from idle to 4,000 rpm quickly   | Approx. 820 – 3,060 mV                               |
| L/FUEL PRES SEN   | <ul style="list-style-type: none"> <li>• Engine: After warming up</li> <li>• Selector lever: P or N position</li> <li>• A/C switch: OFF</li> <li>• No load</li> </ul>        | Idle  | Approx. 0.45 MPa                                     |
|                   |  | 2,000 rpm   | Approx. 0.45 MPa                                     |
| L/FUEL PRES SEN V | <ul style="list-style-type: none"> <li>• Engine: After warming up</li> <li>• Selector lever: P or N position</li> <li>• A/C switch: OFF</li> <li>• No load</li> </ul>        | Idle  | Approx. 3250 mV                                      |
|                   |  | 3,000 rpm   | Approx. 3100 mV                                      |
| EOP SENSOR        | <ul style="list-style-type: none"> <li>• Engine: After warming up</li> <li>• Selector lever: P or N position</li> <li>• A/C switch: OFF</li> <li>• No load</li> </ul>        | Idle  | Approx. 1450 mV                                      |
|                   |  | 2,000 rpm   | Approx. 2850 mV                                      |
| ECM TEMP 1        | <ul style="list-style-type: none"> <li>• Engine: After warming up</li> <li>• Selector lever: P or N position</li> <li>• A/C switch: OFF</li> <li>• No load</li> </ul>        | Idle  | Indicates the temperature of ECM internal circuit 1. |

# ECM

< ECU DIAGNOSIS INFORMATION >

[VK56VD FOR USA AND CANADA]

| Monitor Item   | Condition   | Values/Status  |
|----------------|---|--|
| ECM TEMP 2     | <ul style="list-style-type: none"> <li>Engine: After warming up</li> <li>Selector lever: P or N position</li> <li>A/C switch: OFF</li> <li>No load</li> </ul> <p style="text-align: center;">Idle</p>               | Indicates the temperature of ECM internal circuit 2. |
| FUEL PUMP DUTY | <ul style="list-style-type: none"> <li>Engine: After warming up</li> <li>Shift lever: P or N</li> <li>Air conditioner switch: OFF</li> <li>No load</li> </ul> <p style="text-align: center;">Engine speed: Idle</p> | 30 - 40%   |

\*1: Accelerator pedal position sensor 2 signal and throttle position sensor 2 signal are converted by ECM internally. Thus, they differ from ECM terminals voltage signal.

\*2: Before measuring the terminal voltage, confirm that the battery is fully charged. Refer to [PG-135. "How to Handle Battery"](#).

## TERMINAL LAYOUT

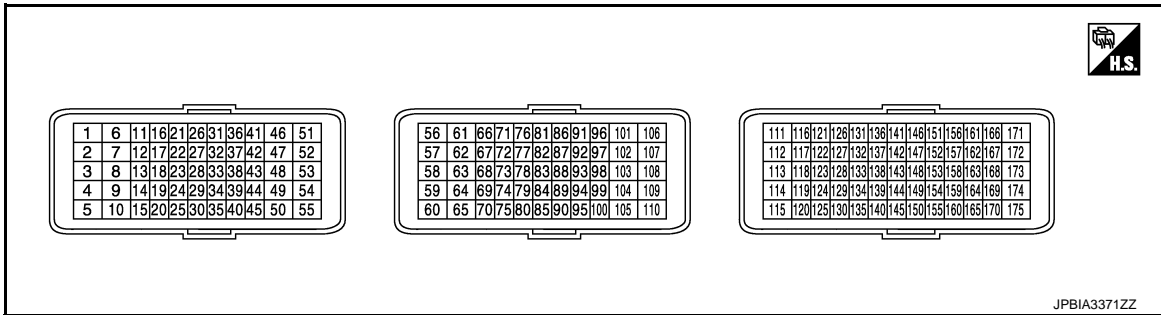

## PHYSICAL VALUES

### NOTE:

- Specification data are reference values and are measured between each terminals.
- Pulse signal is measured by CONSULT.

| Terminal No.<br>(Wire color) |            | Description  |                  | Condition  | Value<br>(Approx.)   |
|------------------------------|------------|--|------------------|--|--|
| +                            | -          | Signal name  | Input/<br>Output |  |  |
| 1<br>(Y)<br>2<br>(L)         | 175<br>(B) | Fuel injector No. 8 (HI)<br>Fuel injector No. 5 (HI) | Output           | [Engine is running] <ul style="list-style-type: none"> <li>Warm-up condition</li> <li>Idle speed</li> </ul> <b>NOTE:</b><br>The pulse cycle changes depending on rpm at idle | BATTERY VOLTAGE<br>(11 - 14 V)★<br>100mSec/div<br><br>20V/div<br>JPBIA3345ZZ |
|                              |            |  |                  | [Engine is running] <ul style="list-style-type: none"> <li>Warm-up condition</li> <li>Engine speed: 2,000 rpm</li> </ul>   | BATTERY VOLTAGE<br>(11 - 14 V)★<br>100mSec/div<br><br>20V/div<br>JPBIA3347ZZ |

# ECM

< ECU DIAGNOSIS INFORMATION >

[VK56VD FOR USA AND CANADA]

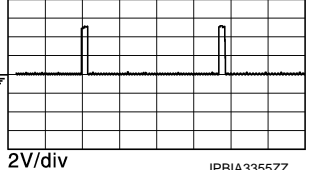
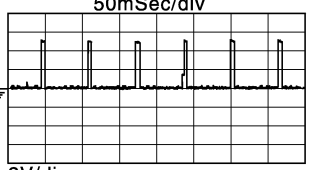
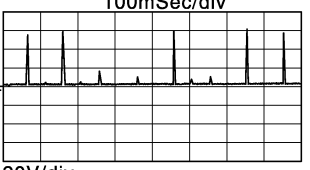
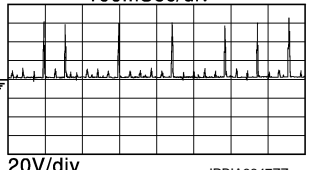
| Terminal No.<br>(Wire color) |            | Description  |                  | Condition  | Value<br>(Approx.)   |
|------------------------------|------------|--|------------------|--|--|
| +                            | -          | Signal name  | Input/<br>Output |  |  |
| 3<br>(Y)<br>4<br>(L)         | 175<br>(B) | Fuel injector No. 3 (LO)<br>Fuel injector No. 2 (LO) | Input            | [Engine is running]<br>• Warm-up condition<br>• Idle speed<br><b>NOTE:</b><br>The pulse cycle changes depending on rpm at idle | BATTERY VOLTAGE<br>(11 - 14 V)★<br>   |
|                              |            |  |                  | [Engine is running]<br>• Warm-up condition<br>• Engine speed: 2,000 rpm  | BATTERY VOLTAGE<br>(11 - 14 V)★<br>   |
| 5<br>(B)                     | —          | ECM ground   | —                | —  | —  |
| 6<br>(BR)<br>7<br>(B/W)      | 175<br>(B) | Fuel injector No. 3 (HI)<br>Fuel injector No. 2 (HI) | Output           | [Engine is running]<br>• Warm-up condition<br>• Idle speed<br><b>NOTE:</b><br>The pulse cycle changes depending on rpm at idle | BATTERY VOLTAGE<br>(11 - 14 V)★<br> |
|                              |            |  |                  | [Engine is running]<br>• Warm-up condition<br>• Engine speed: 2,000 rpm  | BATTERY VOLTAGE<br>(11 - 14 V)★<br> |

# ECM

< ECU DIAGNOSIS INFORMATION >

[VK56VD FOR USA AND CANADA]

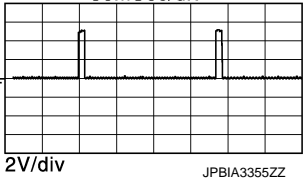
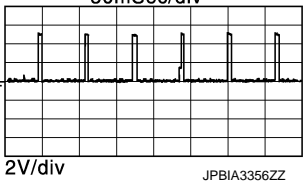
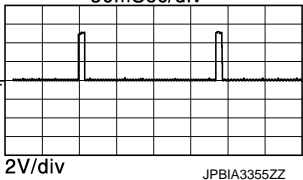
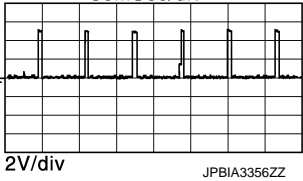
| Terminal No.<br>(Wire color)                     |            | Description  |                  | Condition  | Value<br>(Approx.)   |
|--|------------|--|------------------|--|--|
| +  | -          | Signal name  | Input/<br>Output |  |  |
| 8<br>(BR)<br>9<br>(B/W)                          | 175<br>(B) | Fuel injector No. 8 (LO)<br>Fuel injector No. 5 (LO)   | Input            | [Engine is running]<br>• Warm-up condition<br>• Idle speed<br><b>NOTE:</b><br>The pulse cycle changes depending on rpm at idle | BATTERY VOLTAGE<br>(11 - 14 V)★<br> |
|  |            |  |                  | [Engine is running]<br>• Warm-up condition<br>• Engine speed: 2,000 rpm  | BATTERY VOLTAGE<br>(11 - 14 V)★<br> |
| 10<br>(GR)                                       | —          | ECM ground   | —                | —  | —  |
| 11<br>(LG)                                       | 175<br>(B) | PNP signal   | Input            | [Ignition switch: ON]<br>• Selector lever: P or N position   | BATTERY VOLTAGE<br>(11 - 14 V)   |
|  |            |  |                  | [Ignition switch: ON]<br>• Selector lever: Except above position   | 0 V  |
| 12<br>(O)<br>13<br>(L)<br>14<br>(G)<br>15<br>(R) | 175<br>(B) | Ignition signal No. 1<br>Ignition signal No. 2<br>Ignition signal No. 3<br>Ignition signal No. 4 | Input            | [Engine is running]<br>• Warm-up condition<br>• Idle speed<br><b>NOTE:</b><br>The pulse cycle changes depending on rpm at idle | 0 - 0.2 V★<br>                    |
|  |            |  |                  | [Engine is running]<br>• Warm-up condition<br>• Engine speed: 2,000 rpm  | 0.1 - 0.4 V★<br>                  |

A  
EC  
C  
D  
E  
F  
G  
H  
I  
J  
K  
L  
M  
N  
O  
P

# ECM

< ECU DIAGNOSIS INFORMATION >

[VK56VD FOR USA AND CANADA]

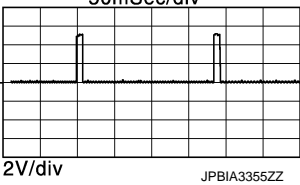
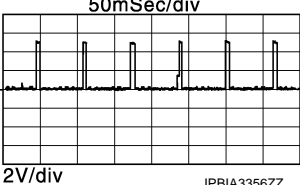
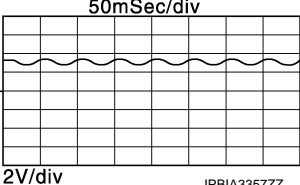
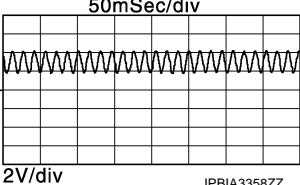
| Terminal No.<br>(Wire color)                      |            | Description  | Input/<br>Output | Condition  | Value<br>(Approx.)   |
|---|------------|--|------------------|--|--|
| +   | -          | Signal name  |                  |  |  |
| 17<br>(LG)<br>18<br>(V)<br>19<br>(L)<br>20<br>(G) | 175<br>(B) | Ignition signal No. 5<br>Ignition signal No. 6<br>Ignition signal No. 7<br>Ignition signal No. 8 | Input            | [Engine is running]<br>• Warm-up condition<br>• Idle speed<br><b>NOTE:</b><br>The pulse cycle changes depending on rpm at idle | 0 - 0.2 V★<br>    |
|   |            |  |                  | [Engine is running]<br>• Warm-up condition<br>• Engine speed: 2,000 rpm  | 0.1 - 0.4 V★<br>  |
| 21<br>(R)   | 25<br>(P)  | Intake air temperature sensor  | Input            | [Engine is running]  | 0 - 4.8 V<br>Output voltage varies with intake air temperature.                                      |
| 22<br>(GR) <sup>*1</sup><br>(B) <sup>*2</sup>     | 25<br>(P)  | Mass air flow sensor (bank 1)  | Input            | [Engine is running]<br>• Warm-up condition<br>• Idle speed   | 0.95 - 1.35 V  |
|   |            |  |                  | [Engine is running]<br>• Warm-up condition<br>• Engine speed: 2,500 rpm  | 1.3 - 1.7 V  |
| 23<br>(B)   | 45<br>(V)  | Low fuel pressure sensor   | Input            | [Engine is running]<br>• Warm-up condition<br>• Idle speed   | 2.4 - 3.6 V<br> |
|   |            |  |                  | [Engine is running]<br>• Warm-up condition<br>• Engine speed: 2,000 rpm  | 2.4 - 3.6 V<br> |
| 24<br>(B) <sup>*1</sup><br>(BR) <sup>*2</sup>     | 30<br>(O)  | Mass air flow sensor (bank 2)  | Input            | [Engine is running]<br>• Warm-up condition<br>• Idle speed   | 0.95 - 1.35 V  |
|   |            |  |                  | [Engine is running]<br>• Warm-up condition<br>• Engine speed: 2,500 rpm  | 1.3 - 1.7 V  |
| 25<br>(P)   | —          | Sensor ground<br>[Mass air flow sensor (bank 1)/<br>Intake air temperature sensor]               | —                | —  | —  |
| 27<br>(G)   | 45<br>(V)  | Sensor power supply<br>(Power steering pressure sensor/<br>Low fuel pressure sensor)             | —                | [Ignition switch: ON]  | 5 V  |



# ECM

< ECU DIAGNOSIS INFORMATION >

[VK56VD FOR USA AND CANADA]

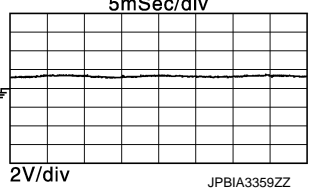
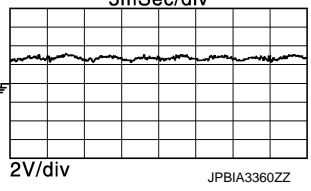
| Terminal No.<br>(Wire color) |           | Description   |                  | Condition   | Value<br>(Approx.)  |
|------------------------------|-----------|---|------------------|---|---|
| +                            | -         | Signal name   | Input/<br>Output |   |   |
| 28<br>(W)                    | 40<br>(B) | Sensor power supply<br>(Fuel rail pressure sensor/Engine oil pressure sensor)   | —                | [Ignition switch: ON]   | 5 V   |
| 29<br>(W)                    | 35<br>(—) | Knock sensor (bank 1)   | Input            | [Engine is running]<br>• Idle speed   | 2.5 V*3   |
| 30<br>(O)                    | —         | Sensor ground<br>[Mass air flow sensor (bank 2)]  | —                | —   | —   |
| 31<br>(G)                    | 40<br>(B) | Fuel rail pressure sensor   | Input            | [Engine is running]<br>• Warm-up condition<br>• Idle speed                                    | 0.82 - 1.22 V   |
|                              |           |   |                  | [Engine is running]<br>• Warm-up condition<br>• Revving engine from idle to 4,000 rpm quickly | 0.82 - 3.06 V   |
| 32<br>(Y)                    | 40<br>(B) | Engine coolant temperature sensor   | Input            | [Engine is running]   | 0 - 4.8 V<br>Output voltage varies with engine coolant temperature.                             |
| 33<br>(GR)                   | 35<br>(—) | Knock sensor (bank 2)   | Input            | [Engine is running]<br>• Idle speed   | 2.5 V*3   |
| 35<br>(—)                    | —         | Sensor ground<br>(Knock sensor)   | —                | —   | —   |
| 39<br>(LG)                   | 45<br>(V) | Power steering pressure sensor  | Input            | [Engine is running]<br>• Steering wheel: Being turned   | 0.5 - 4.5 V   |
|                              |           |   |                  | [Engine is running]<br>• Steering wheel: Not being turned                                     | 0.4 - 0.8 V   |
| 40<br>(B)                    | —         | Sensor ground<br>(Fuel rail pressure sensor/Engine oil pressure sensor/Engine coolant temperature sensor/Engine oil temperature sensor) | —                | —   | —   |
| 41<br>(Y)                    | 40<br>(B) | Engine oil pressure sensor  | Input            | [Engine is running]<br>• Warm-up condition<br>• Idle speed                                    | 1.3 V★<br> |
|                              |           |   |                  | [Engine is running]<br>• Warm-up condition<br>• Engine speed: 2,000 rpm                       | 2.7 V★<br> |
| 42<br>(L)*1<br>(B)*2         | 40<br>(B) | Engine oil temperature sensor   | Input            | [Engine is running]   | 0 - 4.8 V<br>Output voltage varies with engine oil temperature.                                 |
| 45<br>(V)                    | —         | Sensor ground<br>(Power steering pressure sensor/ Low fuel pressure sensor)   | —                | —   | —   |

A  
EC  
C  
D  
E  
F  
G  
H  
I  
J  
K  
L  
M  
N  
O  
P

# ECM

< ECU DIAGNOSIS INFORMATION >

[VK56VD FOR USA AND CANADA]

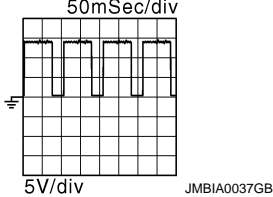
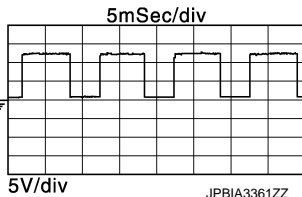
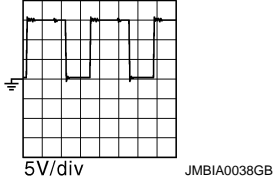
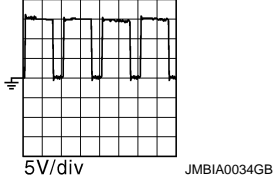
| Terminal No.<br>(Wire color) |            | Description  | Input/<br>Output | Condition  | Value<br>(Approx.)  |
|------------------------------|------------|--|------------------|--|---|
| +                            | -          |  |                  |  |   |
| 46<br>(LG)                   | 175<br>(B) | Fuel injector driver power supply                    | Input            | [Ignition switch: ON]  | BATTERY VOLTAGE<br>(11 - 14 V)  |
| 47<br>(BR)                   | 175<br>(B) | Heated oxygen sensor 2 heater (bank 1)               | Input            | [Engine is running] <ul style="list-style-type: none"> <li>• Engine speed: Below 3,600 rpm after the following conditions are met</li> <li>- Engine: after warming up</li> <li>- Keeping the engine speed between 3,500 and 4,000 rpm for 1 minute and at idle for 1 minute under no load</li> </ul> | 10 V★<br>        |
|                              |            |  |                  | [Ignition switch: ON] <ul style="list-style-type: none"> <li>• Engine: Stopped</li> <li>[Engine is running]</li> <li>• Engine speed: Above 3,600 rpm</li> </ul>  | BATTERY VOLTAGE<br>(11 - 14 V)  |
| 48<br>(Y)                    | 175<br>(B) | A/F sensor 1 heater (bank 1)                         | Input            | [Engine is running] <ul style="list-style-type: none"> <li>• Warm-up condition</li> <li>• Idle speed (More than 140 seconds after starting engine)</li> </ul>  | 2.9 - 8.8 V★<br> |
| 49<br>(GR)                   | 175<br>(B) | Intake valve timing control solenoid valve (bank 2)  | Output           | [Engine is running] <ul style="list-style-type: none"> <li>• Warm-up condition</li> <li>• Idle speed</li> </ul>  | BATTERY VOLTAGE<br>(11 - 14 V)  |
|                              |            |  |                  | [Engine is running] <ul style="list-style-type: none"> <li>• Warm-up condition</li> <li>• Engine speed: 2,000rpm</li> </ul>  | 7 - 12 V★<br>  |
| 50<br>(V)                    | 175<br>(B) | Exhaust valve timing control solenoid valve (bank 2) | Output           | [Engine is running] <ul style="list-style-type: none"> <li>• Warm-up condition</li> <li>• Idle speed</li> </ul>  | BATTERY VOLTAGE<br>(11 - 14 V)  |
|                              |            |  |                  | [Engine is running] <ul style="list-style-type: none"> <li>• Warm-up condition</li> <li>• Around 2,500 rpm while the engine speed is rising</li> </ul>   | 7 - 12 V★<br>  |
| 51<br>(W)                    | 175<br>(B) | Fuel injector driver power supply                    | Output           | [Engine is running] <ul style="list-style-type: none"> <li>• Warm-up condition</li> <li>• Idle speed</li> </ul>  | BATTERY VOLTAGE<br>(11 - 14 V)  |

# ECM

< ECU DIAGNOSIS INFORMATION >

[VK56VD FOR USA AND CANADA]

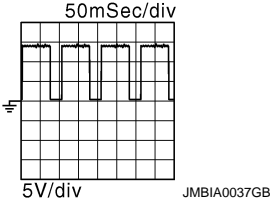
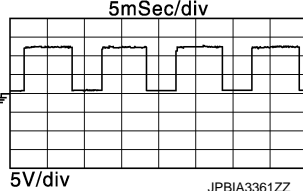
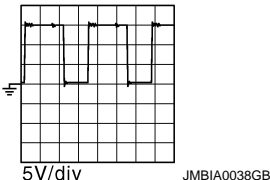
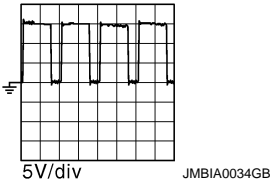
| Terminal No.<br>(Wire color) |            | Description  |                  | Condition  | Value<br>(Approx.)  |
|------------------------------|------------|--|------------------|--|---|
| +                            | -          | Signal name  | Input/<br>Output |  |   |
| 52<br>(G)                    | 175<br>(B) | Heated oxygen sensor 2 heater (bank 2)               | Output           | [Engine is running] <ul style="list-style-type: none"> <li>• Engine speed: Below 3,600 rpm after the following conditions are met</li> <li>- Engine: after warming up</li> <li>- Keeping the engine speed between 3,500 and 4,000 rpm for 1 minute and at idle for 1 minute under no load</li> </ul> | 10 V★<br>        |
|                              |            |  |                  | [Ignition switch: ON] <ul style="list-style-type: none"> <li>• Engine: Stopped</li> </ul> [Engine is running] <ul style="list-style-type: none"> <li>• Engine speed: Above 3,600 rpm</li> </ul>  | BATTERY VOLTAGE<br>(11 - 14 V)  |
| 53<br>(P)                    | 175<br>(B) | A/F sensor 1 heater (bank 2)                         | Output           | [Engine is running] <ul style="list-style-type: none"> <li>• Warm-up condition</li> <li>• Idle speed (More than 140 seconds after starting engine)</li> </ul>  | 2.9 - 8.8 V★<br> |
| 54<br>(SB)                   | 175<br>(B) | Intake valve timing control solenoid valve (bank 1)  | Output           | [Engine is running] <ul style="list-style-type: none"> <li>• Warm-up condition</li> <li>• Idle speed</li> </ul>  | BATTERY VOLTAGE<br>(11 - 14 V)  |
|                              |            |  |                  | [Engine is running] <ul style="list-style-type: none"> <li>• Warm-up condition</li> <li>• Engine speed: 2,000rpm</li> </ul>  | 7 - 12 V★<br>  |
| 55<br>(R)                    | 175<br>(B) | Exhaust valve timing control solenoid valve (bank 1) | Output           | [Engine is running] <ul style="list-style-type: none"> <li>• Warm-up condition</li> <li>• Idle speed</li> </ul>  | BATTERY VOLTAGE<br>(11 - 14 V)  |
|                              |            |  |                  | [Engine is running] <ul style="list-style-type: none"> <li>• Warm-up condition</li> <li>• Around 2,500 rpm while the engine speed is rising</li> </ul>   | 7 - 12 V★<br>  |

A  
EC  
C  
D  
E  
F  
G  
H  
I  
J  
K  
L  
M  
N  
O  
P

# ECM

< ECU DIAGNOSIS INFORMATION >

[VK56VD FOR USA AND CANADA]

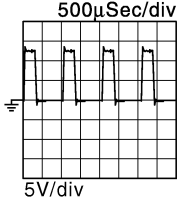
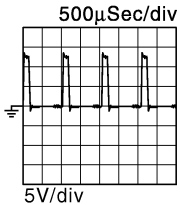
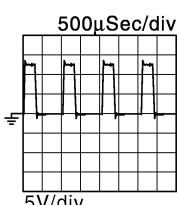
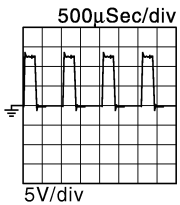
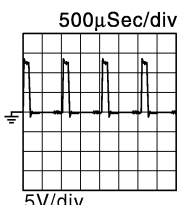
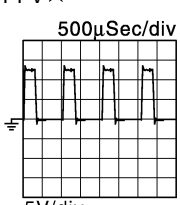
| Terminal No.<br>(Wire color) |            | Description                                |                  | Condition  | Value<br>(Approx.)   |
|------------------------------|------------|--|------------------|--|--|
| +                            | -          | Signal name                                | Input/<br>Output |  |  |
| 57<br>(L)                    | 175<br>(B) | Throttle control motor (bank 1)<br>(Open)  | Output           | [Ignition switch: ON]<br>• Engine: Stopped<br>• Selector lever: D<br>• Accelerator pedal: Fully depressed                                  | 0 - 14 V★<br><br><small>JMBIA0031GB</small>   |
|                              |            |  |                  | [Ignition switch: ON]<br>• Engine: Stopped<br>• Selector lever: D position<br>• Accelerator pedal: Fully released                          | 0 - 14 V★<br><br><small>JMBIA0032GB</small>   |
| 58<br>(G)                    | 175<br>(B) | Throttle control motor (bank 2)<br>(Close) | Output           | [Ignition switch: ON]<br>• Engine: Stopped<br>• Selector lever: D position<br>• Accelerator pedal: In the middle of<br>releasing operation | 0 - 14 V★<br><br><small>JMBIA0031GB</small>  |
| 60<br>(B/W)                  | —          | Shield                                     | —                | —  | —  |
| 62<br>(R)                    | 175<br>(B) | Throttle control motor (bank 2)<br>(Open)  | Output           | [Ignition switch: ON]<br>• Engine: Stopped<br>• Selector lever: D<br>• Accelerator pedal: Fully depressed                                  | 0 - 14 V★<br><br><small>JMBIA0031GB</small> |
|                              |            |  |                  | [Ignition switch: ON]<br>• Engine: Stopped<br>• Selector lever: D position<br>• Accelerator pedal: Fully released                          | 0 - 14 V★<br><br><small>JMBIA0032GB</small> |
| 63<br>(P)                    | 175<br>(B) | Throttle control motor (bank 1)<br>(Close) | Output           | [Ignition switch: ON]<br>• Engine: Stopped<br>• Selector lever: D position<br>• Accelerator pedal: In the middle of<br>releasing operation | 0 - 14 V★<br><br><small>JMBIA0031GB</small> |

# ECM

< ECU DIAGNOSIS INFORMATION >

[VK56VD FOR USA AND CANADA]

| Terminal No.<br>(Wire color) |             | Description  |                  | Condition   | Value<br>(Approx.)                  |
|------------------------------|-------------|--|------------------|---|-------------------------------------|
| +                            | -           | Signal name  | Input/<br>Output |   |                                     |
| 64<br>(GR)                   | 175<br>(B)  | EVAP canister purge volume control solenoid valve  | Output           | [Engine is running] <ul style="list-style-type: none"> <li>• Idle speed</li> <li>• Accelerator pedal: Not depressed even slightly, after engine starting</li> </ul>           | BATTERY VOLTAGE<br>(11 - 14 V)★<br> |
|                              |             |  |                  | [Engine is running] <ul style="list-style-type: none"> <li>• Engine speed: About 2,000 rpm (More than 100 seconds after starting engine)</li> </ul>                           | BATTERY VOLTAGE<br>(11 - 14 V)★<br> |
| 67<br>(R)                    | 175<br>(B)  | Manifold absolute pressure sensor  | Input            | [Engine is running] <ul style="list-style-type: none"> <li>• Warm-up condition</li> <li>• Idle speed</li> </ul>   | 1.2 V                               |
|                              |             |  |                  | [Engine is running] <ul style="list-style-type: none"> <li>• Warm-up condition</li> <li>• Engine speed: 2,000 rpm</li> </ul>  | 1.5 V                               |
| 68<br>(L)                    | —           | Sensor ground<br>[Camshaft position sensor (bank 1)/Exhaust valve timing control position sensor (bank 1)] | —                | —   | —                                   |
| 69<br>(O/L)                  | —           | Sensor ground<br>[Throttle position sensor (bank 2)]   | —                | —   | —                                   |
| 70<br>(G)                    | —           | Sensor ground<br>(Manifold absolute pressure sensor)   | —                | —   | —                                   |
| 71<br>(O)                    | 69<br>(O/L) | Throttle position sensor 1 (bank 2)  | Input            | [Ignition switch: ON] <ul style="list-style-type: none"> <li>• Engine: Stopped</li> <li>• Selector lever: D position</li> <li>• Accelerator pedal: Fully released</li> </ul>  | More than 0.36 V                    |
|                              |             |  |                  | [Ignition switch: ON] <ul style="list-style-type: none"> <li>• Engine: Stopped</li> <li>• Selector lever: D position</li> <li>• Accelerator pedal: Fully depressed</li> </ul> | Less than 4.75 V                    |

A

EC

C

D

E

F

G

H

I

J

K

L

M

N

O

P

# ECM

< ECU DIAGNOSIS INFORMATION >

[VK56VD FOR USA AND CANADA]

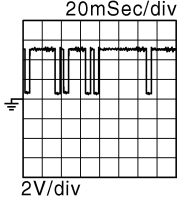
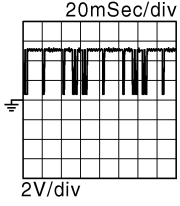
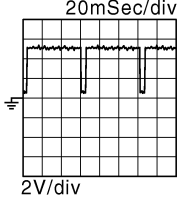
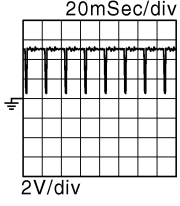
| Terminal No.<br>(Wire color) |            | Description   |                  | Condition   | Value<br>(Approx.)  |
|------------------------------|------------|---|------------------|---|---|
| +                            | -          | Signal name   | Input/<br>Output |   |   |
| 73<br>(B)                    | 99<br>(R)  | Camshaft position sensor<br>(bank 2)                          | Input            | [Engine is running]<br>• Warm-up condition<br>• Idle speed<br><b>NOTE:</b><br>The pulse cycle changes depending<br>on rpm at idle | 3.0 - 5.0 V★<br> JMBIA0045GB   |
|                              |            |   |                  | [Engine is running]<br>• Engine speed: 2,000 rpm  | 3.0 - 5.0 V★<br> JMBIA0046GB   |
| 74<br>(L/W)                  | 175<br>(B) | A/F sensor 1 (bank 2)   | Input            | [Ignition switch: ON]   | 2.5 V   |
| 75<br>(R)                    | 68<br>(L)  | Exhaust valve timing control<br>position sensor (bank 1)      | Input            | [Engine is running]<br>• Warm-up condition<br>• Idle speed<br><b>NOTE:</b><br>The pulse cycle changes depending<br>on rpm at idle | 4.0 - 5.0 V★<br> JMBIA0043GB  |
|                              |            |   |                  | [Engine is running]<br>• Warm-up condition<br>• Engine speed: 2,000 rpm   | 4.0 - 5.0 V★<br> JMBIA0044GB |
| 76<br>(B)                    | 86<br>(L)  | Sensor power supply<br>(Crankshaft position sensor)           | —                | [Ignition switch: ON]   | 5 V   |
| 77<br>(B)                    | 68<br>(L)  | Sensor power supply<br>[Camshaft position sensor<br>(bank 1)] | —                | [Ignition switch: ON]   | 5 V   |
| 78<br>(L/R)                  | 175<br>(B) | A/F sensor 1 (bank 2)   | Input            | [Engine is running]<br>• Warm-up condition<br>• Engine speed: 2,000 rpm   | 2.2 - 2.8V<br>Output voltage varies with air fuel<br>ratio.   |
| 79<br>(B)                    | 97<br>(G)  | Throttle position sensor 2<br>(bank 1)                        | Input            | [Ignition switch: ON]<br>• Engine: Stopped<br>• Selector lever: D position<br>• Accelerator pedal: Fully released                 | Less than 4.75 V  |
|                              |            |   |                  | [Ignition switch: ON]<br>• Engine: Stopped<br>• Selector lever: D position<br>• Accelerator pedal: Fully depressed                | More than 0.36 V  |
| 80<br>(L)                    | 175<br>(B) | Sensor power supply<br>[A/F sensor 1 (bank 2)]                | —                | [Ignition switch: ON]   | 3.0 V   |

# ECM

## < ECU DIAGNOSIS INFORMATION >

## [VK56VD FOR USA AND CANADA]

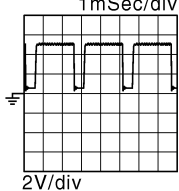
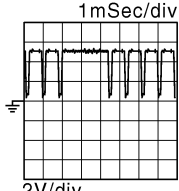
| Terminal No.<br>(Wire color) |             | Description  | Input/<br>Output | Condition   | Value<br>(Approx.)   |
|------------------------------|-------------|--|------------------|---|--|
| +                            | -           |  |                  |   |  |
| 81<br>(W)                    | 97<br>(G)   | Sensor power supply<br>[Throttle position sensor (bank 1)] | —                | [Ignition switch: ON]   | 5 V  |
| 82<br>(W)                    | 69<br>(O/L) | Sensor power supply<br>[Throttle position sensor (bank 2)] | —                | [Ignition switch: ON]   | 5 V  |
| 83<br>(L)                    | 175<br>(B)  | Sensor power supply<br>[Camshaft position sensor (bank 2)] | —                | [Ignition switch: ON]   | 5 V  |
| 85<br>(W)                    | 175<br>(B)  | Sensor power supply<br>(Manifold absolute pressure sensor) | —                | [Ignition switch: ON]   | 5 V  |
| 86<br>(L)                    | 98<br>(R)   | Crankshaft position sensor                                 | Input            | [Engine is running]<br>• Warm-up condition<br>• Idle speed<br><b>NOTE:</b><br>The pulse cycle changes depending on rpm at idle  | 4.0 - 5.0 V★<br>  |
|                              |             |  |                  | [Engine is running]<br>• Engine speed: 2,000 rpm  | 4.0 - 5.0 V★<br> |
| 87<br>(BR)                   | 100<br>(P)  | Heated oxygen sensor 2 (bank 2)                            | Input            | [Engine is running]<br>• Revving engine from idle to 3,000 rpm quickly after the following conditions are met<br>- Engine: after warming up<br>- Keeping the engine speed between 3,500 and 4,000 rpm for 1 minute and at idle for 1 minute under no load | 0 - 1.0 V  |
| 88<br>(L/W)                  | 175<br>(B)  | A/F sensor 1 (bank 1)                                      | Input            | [Engine is running]<br>• Warm-up condition<br>• Engine speed: 2,000 rpm   | 2.2 - 2.8 V<br>Output voltage varies with air fuel ratio.  |
| 89<br>(W/L)                  | 69<br>(O/L) | Throttle position sensor 2 (bank 2)                        | Input            | [Ignition switch: ON]<br>• Engine: Stopped<br>• Selector lever: D position<br>• Accelerator pedal: Fully released   | Less than 4.75 V   |
|                              |             |  |                  | [Ignition switch: ON]<br>• Engine: Stopped<br>• Selector lever: D position<br>• Accelerator pedal: Fully depressed  | More than 0.36 V   |
| 90<br>(L/R)                  | 175<br>(B)  | Sensor power supply<br>[A/F sensor 1 (bank 1)]             | —                | [Ignition switch: ON]   | 3.0 V  |

A

EC

C

D

E

F

G

H

I

J

K

L

M

N

O

P

# ECM

< ECU DIAGNOSIS INFORMATION >

[VK56VD FOR USA AND CANADA]

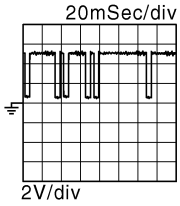
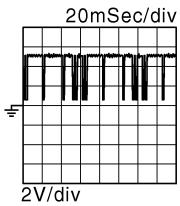
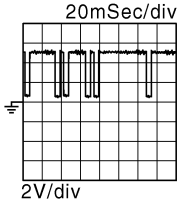
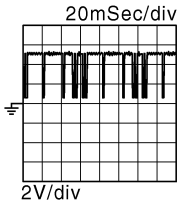
| Terminal No.<br>(Wire color) |            | Description  | Input/<br>Output | Condition  | Value<br>(Approx.)   |
|------------------------------|------------|--|------------------|--|--|
| +                            | -          | Signal name  |                  |  |  |
| 91<br>(R)                    | 175<br>(B) | Throttle position sensor 1<br>(bank 1)                   | Input            | [Ignition switch: ON]<br>• Engine: Stopped<br>• Selector lever: D position<br>• Accelerator pedal: Fully released  | More than 0.36 V   |
|                              |            |  |                  | [Ignition switch: ON]<br>• Engine: Stopped<br>• Selector lever: D position<br>• Accelerator pedal: Fully depressed   | Less than 4.75 V   |
| 93<br>(B)                    | 99<br>(R)  | Exhaust valve timing control<br>position sensor (bank 2) | Input            | [Engine is running]<br>• Warm-up condition<br>• Idle speed<br><b>NOTE:</b><br>The pulse cycle changes depending<br>on rpm at idle  | 3.0 - 5.0 V★<br><br>JMBIA0045GB   |
|                              |            |  |                  | [Engine is running]<br>• Engine speed: 2,000 rpm   | 3.0 - 5.0 V★<br><br>JMBIA0046GB  |
| 94<br>(L)                    | 175<br>(B) | A/F sensor 1 (bank 1)                                    | Input            | [Ignition switch: ON]  | 2.0 V  |
| 95<br>(R)                    | 68<br>(L)  | Camshaft position sensor<br>(bank 1)                     | Input            | [Engine is running]<br>• Warm-up condition<br>• Idle speed<br><b>NOTE:</b><br>The pulse cycle changes depending<br>on rpm at idle  | 3.0 - 5.0 V★<br><br>JMBIA0045GB |
|                              |            |  |                  | [Engine is running]<br>• Engine speed: 2,000 rpm   | 3.0 - 5.0 V★<br><br>JMBIA0046GB |
| 96<br>(Y)                    | 100<br>(P) | Heated oxygen sensor 2 (bank<br>1)                       | Input            | [Engine is running]<br>• Revving engine from idle to 3,000<br>rpm quickly after the following condi-<br>tions are met<br>- Engine: after warming up<br>- Keeping the engine speed between<br>3,500 and 4,000 rpm for 1 minute<br>and at idle for 1 minute under no<br>load | 0 - 1.0 V  |
| 97<br>(G)                    | —          | Sensor ground<br>[Throttle position sensor (bank<br>1)]  | —                | —  | —  |



# ECM

< ECU DIAGNOSIS INFORMATION >

[VK56VD FOR USA AND CANADA]

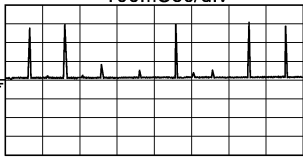
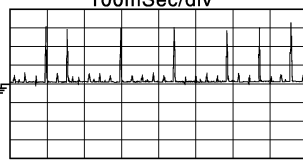
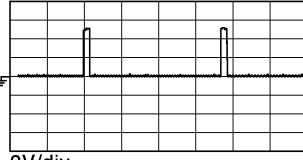
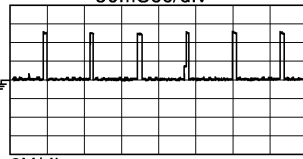

| Terminal No.<br>(Wire color) |            | Description   |                  | Condition   | Value<br>(Approx.)  |
|------------------------------|------------|---|------------------|---|---|
| +                            | -          | Signal name   | Input/<br>Output |   |   |
| 98<br>(R)                    | —          | Sensor ground<br>(Crankshaft position sensor)   | —                | —   | —   |
| 99<br>(R)                    | —          | Sensor ground<br>[Camshaft position sensor<br>(bank 2)/Exhaust valve timing<br>control position sensor (bank<br>2)] | —                | —   | —   |
| 100<br>(P)                   | —          | Sensor ground<br>(Heated oxygen sensor 2)   | —                | —   | —   |
| 101<br>(Y)<br>102<br>(L)     | 175<br>(B) | Fuel injector No. 1 (HI)<br>Fuel injector No. 6 (HI)  | Input            | [Engine is running]<br>• Warm-up condition<br>• Idle speed<br><b>NOTE:</b><br>The pulse cycle changes depending<br>on rpm at idle | BATTERY VOLTAGE<br>(11 - 14 V)★<br>100mSec/div<br><br>20V/div<br><small>JPBIA3345ZZ</small>  |
|                              |            |   |                  | [Engine is running]<br>• Warm-up condition<br>• Engine speed: 2,000 rpm   | BATTERY VOLTAGE<br>(11 - 14 V)★<br>100mSec/div<br><br>20V/div<br><small>JPBIA3347ZZ</small> |
| 103<br>(B/W)<br>104<br>(BR)  | 175<br>(B) | Fuel injector No. 7 (LO)<br>Fuel injector No. 4 (LO)  | Output           | [Engine is running]<br>• Warm-up condition<br>• Idle speed<br><b>NOTE:</b><br>The pulse cycle changes depending<br>on rpm at idle | BATTERY VOLTAGE<br>(11 - 14 V)★<br>50mSec/div<br><br>2V/div<br><small>JPBIA3355ZZ</small>  |
|                              |            |   |                  | [Engine is running]<br>• Warm-up condition<br>• Engine speed: 2,000 rpm   | BATTERY VOLTAGE<br>(11 - 14 V)★<br>50mSec/div<br><br>2V/div<br><small>JPBIA3356ZZ</small>  |

A  
EC  
C  
D  
E  
F  
G  
H  
I  
J  
K  
L  
M  
N  
O  
P

# ECM

## < ECU DIAGNOSIS INFORMATION >

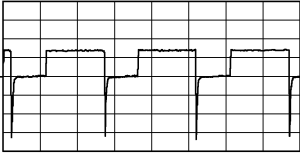
## [VK56VD FOR USA AND CANADA]

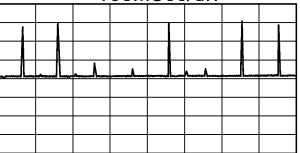
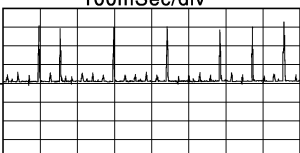
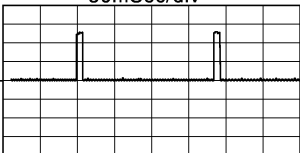
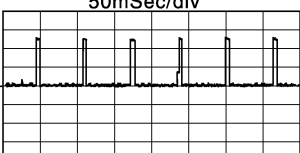
| Terminal No.<br>(Wire color) |            | Description  |                  | Condition  | Value<br>(Approx.)   |
|------------------------------|------------|--|------------------|--|--|
| +                            | -          | Signal name  | Input/<br>Output |  |  |
| 105<br>(W)                   | 175<br>(B) | High pressure fuel pump (HI)                         | Input            | [Engine is running]<br>• Warm-up condition<br>• Idle speed<br><b>NOTE:</b><br>The pulse cycle changes depending on rpm at idle | BATTERY VOLTAGE<br>(11 - 14 V)★<br><br><small>JPBIA3340ZZ</small>   |
|                              |            |  |                  | [Engine is running]<br>• Warm-up condition<br>• Engine speed: 2,000 rpm  | BATTERY VOLTAGE<br>(11 - 14 V)★<br><br><small>JPBIA3341ZZ</small>   |
| 106<br>(L)<br>107<br>(Y)     | 175<br>(B) | Fuel injector No. 7 (HI)<br>Fuel injector No. 4 (HI) | Output           | [Engine is running]<br>• Warm-up condition<br>• Idle speed<br><b>NOTE:</b><br>The pulse cycle changes depending on rpm at idle | BATTERY VOLTAGE<br>(11 - 14 V)★<br><br><small>JPBIA3345ZZ</small>  |
|                              |            |  |                  | [Engine is running]<br>• Warm-up condition<br>• Engine speed: 2,000 rpm  | BATTERY VOLTAGE<br>(11 - 14 V)★<br><br><small>JPBIA3347ZZ</small> |
| 108<br>(BR)<br>109<br>(B/W)  | 175<br>(B) | Fuel injector No. 1 (LO)<br>Fuel injector No. 6 (LO) | Output           | [Engine is running]<br>• Warm-up condition<br>• Idle speed<br><b>NOTE:</b><br>The pulse cycle changes depending on rpm at idle | BATTERY VOLTAGE<br>(11 - 14 V)★<br><br><small>JPBIA3355ZZ</small> |
|                              |            |  |                  | [Engine is running]<br>• Warm-up condition<br>• Engine speed: 2,000 rpm  | BATTERY VOLTAGE<br>(11 - 14 V)★<br><br><small>JPBIA3356ZZ</small> |

# ECM

< ECU DIAGNOSIS INFORMATION >

[VK56VD FOR USA AND CANADA]

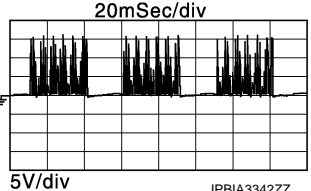
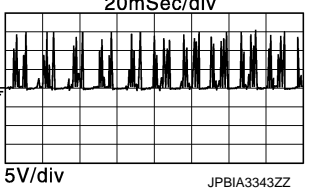
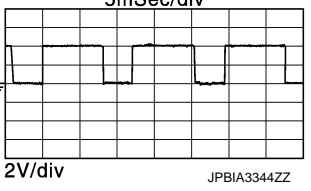
| Terminal No.<br>(Wire color) |  | Description  |                  | Condition  | Value<br>(Approx.)   |
|------------------------------|--|--|------------------|--|--|
| +                            | -  | Signal name  | Input/<br>Output |  |  |
| 110<br>(B)                   | 175<br>(B)                                     | High pressure fuel pump (LO)                                 | Input            | [Engine is running]<br>• Warm-up condition<br>• Idle speed<br><b>NOTE:</b><br>The pulse cycle changes depending on rpm at idle | BATTERY VOLTAGE<br>(11 - 14 V)★<br> |
|                              |  |  |                  | [Engine is running]<br>• Warm-up condition<br>• Engine speed: 2,000 rpm  | BATTERY VOLTAGE<br>(11 - 14 V)★<br> |
| 111<br>(W)                   | 175<br>(B)                                     | Fuel injector driver power supply                            | Input            | [Ignition switch: ON]  | BATTERY VOLTAGE<br>(11 - 14 V)   |
| 112<br>(W)                   | 175<br>(B)                                     | Fuel injector driver power supply                            | Input            | [Ignition switch: ON]  | BATTERY VOLTAGE<br>(11 - 14 V)   |
| 114<br>(B)                   | —  | ECM ground<br>(Fuel injector)                                | —                | —  | —  |
| 115<br>(B)                   | —  | ECM ground<br>(Fuel injector)                                | —                | —  | —  |
| 120<br>(G)                   | 175<br>(B)                                     | EVAP canister vent control valve                             | Output           | [Ignition switch: ON]  | BATTERY VOLTAGE<br>(11 - 14 V)   |
| 122<br>(V)                   | 175<br>(B)                                     | VVEL actuator motor relay abort signal (VVEL control module) | Input            | [Ignition switch: ON]  | 0 V  |
| 123<br>(BG)                  | 175<br>(B)                                     | Throttle control motor relay                                 | Output           | [Ignition switch: ON → OFF]  | 0 - 1.0 V<br>↓<br>BATTERY VOLTAGE<br>(11 - 14 V)<br>↓<br>0 V   |
|                              |  |  |                  | [Ignition switch: ON]  | 0 - 1.0 V  |
| 125<br>(P)                   | 175<br>(B)                                     | Fuel pump control module (FPCM)                              | Output           | [When cranking engine]   | 0 - 0.5 V  |
|                              |  |  |                  | [Engine is running]<br>• Warm-up condition   | 0 - 4.0 V★<br>                    |
| 126<br>(Y)                   | 129<br>(BR) <sup>*1</sup><br>(B) <sup>*2</sup> | Accelerator pedal position sensor 2                          | Input            | [Ignition switch: ON]<br>• Engine: Stopped<br>• Accelerator pedal: Fully released  | 0.22 - 0.5 V   |
|                              |  |  |                  | [Ignition switch: ON]<br>• Engine: Stopped<br>• Accelerator pedal: Fully depressed   | 2.1 - 2.5 V  |

A  
EC  
C  
D  
E  
F  
G  
H  
I  
J  
K  
L  
M  
N  
O  
P

# ECM

< ECU DIAGNOSIS INFORMATION >

[VK56VD FOR USA AND CANADA]

| Terminal No.<br>(Wire color)                   |  | Description   | Input/<br>Output | Condition  | Value<br>(Approx.) |
|--|--|---|------------------|--|--------------------|
| +  | -  | Signal name   |                  |  |                    |
| 128<br>(SB)                                    | 130<br>(Y)                                     | ASCDC steering switch   | Input            | [Ignition switch: ON]<br>• ASCDC steering switch: OFF                              | 4 V                |
|  |  |   |                  | [Ignition switch: ON]<br>• MAIN switch: Pressed                                    | 0 V                |
|  |  |   |                  | [Ignition switch: ON]<br>• CANCEL switch: Pressed                                  | 1 V                |
|  |  |   |                  | [Ignition switch: ON]<br>• RESUME/ACCELERATE switch:<br>Pressed                    | 3 V                |
|  |  |   |                  | [Ignition switch: ON]<br>• SET/COAST switch: Pressed                               | 2 V                |
| 128<br>(SB)                                    | 175<br>(B)                                     | ICC steering switch   | Input            | [Ignition switch: ON]<br>• ICC steering switch: OFF                                | 4.2 V              |
|  |  |   |                  | [Ignition switch: ON]<br>• MAIN switch: Pressed                                    | 0 V                |
|  |  |   |                  | [Ignition switch: ON]<br>• CANCEL switch: Pressed                                  | 1.9 V              |
|  |  |   |                  | [Ignition switch: ON]<br>• RESUME/ACCELERATE switch:<br>Pressed                    | 3.7 V              |
|  |  |   |                  | [Ignition switch: ON]<br>• SET/COAST switch: Pressed                               | 3.2 V              |
|  |  |   |                  | [Ignition switch: ON]<br>• DISTANCE switch: Pressed                                | 2.6 V              |
|  |  |   |                  | [Ignition switch: ON]<br>• DYNAMIC DRIVE ASSISTANCE<br>switch: Pressed             | 1.0 V              |
| 129<br>(BR) <sup>*1</sup><br>(B) <sup>*2</sup> | —  | Sensor ground<br>(Accelerator pedal position<br>sensor 2)   | —                | —  | —                  |
| 130<br>(Y)                                     | —  | Sensor ground<br>(ASCDC steering switch)  | —                | —  | —                  |
| 131<br>(L)                                     | 129<br>(BR) <sup>*1</sup><br>(B) <sup>*2</sup> | Sensor power supply<br>(Accelerator pedal position<br>sensor 2)   | —                | [Ignition switch: ON]  | 5 V                |
| 133<br>(BG)                                    | 150<br>(V)                                     | Sensor power supply<br>[Refrigerant pressure sensor/<br>Battery current sensor/EVAP<br>control system pressure sen-<br>sor] | —                | [Ignition switch: ON]  | 5 V                |
| 134<br>(P)                                     | 175<br>(B)                                     | Fuel temperature sensor   | Input            | [Engine is running]<br>• Warm-up condition   | 2.8 V              |
| 136<br>(R)                                     | 140<br>(W)                                     | Accelerator pedal position<br>sensor 1  | Input            | [Ignition switch: ON]<br>• Engine: Stopped<br>• Accelerator pedal: Fully released  | 0.45 - 1.0 V       |
|  |  |   |                  | [Ignition switch: ON]<br>• Engine: Stopped<br>• Accelerator pedal: Fully depressed | 4.4 - 4.8 V        |
| 137<br>(G)                                     | 140<br>(W)                                     | Sensor power supply<br>(Accelerator pedal position<br>sensor 1)   | —                | [Ignition switch: ON]  | 5 V                |

# ECM

< ECU DIAGNOSIS INFORMATION >

[VK56VD FOR USA AND CANADA]

| Terminal No.<br>(Wire color) |            | Description   |                  | Condition   | Value<br>(Approx.)             |
|------------------------------|------------|---|------------------|---|--------------------------------|
| +                            | -          | Signal name   | Input/<br>Output |   |                                |
| 138<br>(P)                   | 175<br>(B) | Battery current sensor  | Input            | [Engine is running]<br>• Battery: Fully charged*4<br>• Idle speed   | 2.6 - 3.5 V                    |
| 139<br>(BG)                  | 175<br>(B) | Battery temperature sensor  | Input            | [Engine is running]<br>• Battery temperature: 25°C<br>• Idle speed  | 3.3 V                          |
| 140<br>(W)                   | —          | Sensor ground<br>(Accelerator pedal position<br>sensor 1)   | —                | —   | —                              |
| 141<br>(G)                   | 175<br>(B) | Ignition switch   | Input            | [Ignition switch: OFF]  | 0 V                            |
|                              |            |   |                  | [Ignition switch: ON]   | BATTERY VOLTAGE<br>(11 - 14 V) |
| 142<br>(GR)                  | 175<br>(B) | Fuel pump control module<br>(FPCM) check  | Input            | [When cranking engine]  | 0 V                            |
|                              |            |   |                  | [Engine is running]<br>• Warm-up condition<br>• Idle speed  | 9 V                            |
| 143<br>(P)                   | 175<br>(B) | Fuel tank pressure sensor   | Input            | [Engine is running]<br>• Warm-up condition  | 4 V                            |
| 144<br>(LG)                  | 150<br>(V) | Refrigerant pressure sensor   | Input            | [Engine is running]<br>• Warm-up condition<br>• Both A/C switch and blower fan mo-<br>tor switch: ON (Compressor oper-<br>ates) | 1.0 - 4.0 V                    |
| 146<br>(L)                   | —          | CAN communication line  | —                | —   | —                              |
| 147<br>(BR)                  | 175<br>(B) | ASCD/ICC brake switch   | Input            | [Ignition switch: ON]<br>• Brake pedal: Slightly depressed  | 0 V                            |
|                              |            |   |                  | [Ignition switch: ON]<br>• Brake pedal: Fully released  | BATTERY VOLTAGE<br>(11 - 14 V) |
| 150<br>(V)                   | —          | Sensor ground<br>[Refrigerant pressure sensor/<br>Battery current sensor/EVAP<br>control system pressure sen-<br>sor] | —                | —   | —                              |
| 151<br>(P)                   | —          | CAN communication line  | —                | —   | —                              |
| 156<br>(W)                   | 175<br>(B) | Power supply for ECM (Back-<br>up)  | Input            | [Ignition switch: OFF]  | BATTERY VOLTAGE<br>(11 - 14 V) |
| 158<br>(P)                   | 175<br>(B) | Stop lamp switch  | Input            | [Ignition switch: OFF]<br>• Brake pedal: Fully released   | 0 V                            |
|                              |            |   |                  | [Ignition switch: OFF]<br>• Brake pedal: Slightly depressed   | BATTERY VOLTAGE<br>(11 - 14 V) |
| 161<br>(Y)                   | —          | ENG communication line  | —                | —   | —                              |
| 163<br>(W)                   | 175<br>(B) | ECM relay (Self shut-off)   | Output           | [Engine is running]<br>[Ignition switch: OFF]<br>• A few seconds after turning ignition<br>switch OFF                           | 0 - 1.5 V                      |
|                              |            |   |                  | [Ignition switch: OFF]<br>• More than a few seconds after turn-<br>ing ignition switch OFF                                      | BATTERY VOLTAGE<br>(11 - 14 V) |

A

EC

C

D

E

F

G

H

I

J

K

L

M

N

O

P

# ECM

< ECU DIAGNOSIS INFORMATION >

[VK56VD FOR USA AND CANADA]

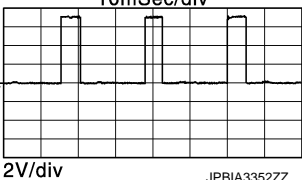
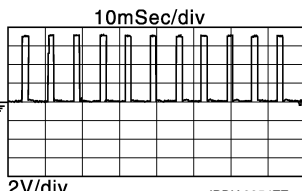
| Terminal No.<br>(Wire color) |            | Description                         |                  | Condition  | Value<br>(Approx.)  |
|------------------------------|------------|-------------------------------------|------------------|--|---|
| +                            | -          | Signal name                         | Input/<br>Output |  |   |
| 166<br>(BG)                  | —          | ENG communication line              | —                | —  | —   |
| 169<br>(V)                   | 175<br>(B) | Engine speed signal output          | Input            | [Engine is running] <ul style="list-style-type: none"> <li>• Warm-up condition</li> <li>• Idle speed</li> </ul> <b>NOTE:</b><br>The pulse cycle changes depending on rpm at idle | 0 - 7.0 V★<br> |
|                              |            |                                     |                  | [Engine is running] <ul style="list-style-type: none"> <li>• Warm-up condition</li> <li>• Engine speed: 2,000 rpm</li> </ul>   | 0 - 7.0 V★<br> |
| 171<br>(SB)                  | 175<br>(B) | Power supply for ECM                | Input            | [Ignition switch: ON]  | BATTERY VOLTAGE<br>(11 - 14 V)  |
| 172<br>(SB)                  | 175<br>(B) | Power supply for ECM                | Input            | [Ignition switch: ON]  | BATTERY VOLTAGE<br>(11 - 14 V)  |
| 173<br>(R)                   | 175<br>(B) | Throttle control motor power supply | Input            | [Ignition switch: ON]  | BATTERY VOLTAGE<br>(11 - 14 V)  |
| 174<br>(B)                   | —          | ECM ground                          | —                | —  | —   |
| 175<br>(B)                   | —          | ECM ground                          | —                | —  | —   |

★: Average voltage for pulse signal (Actual pulse signal can be confirmed by oscilloscope.)

\*1: With ICC.

\*2: Without ICC.

\*3: This may vary depending on internal resistance of the tester.

\*4: Before measuring the terminal voltage, confirm that the battery is fully charged. Refer to [PG-135, "How to Handle Battery"](#).

## Fail-safe

INFOID:000000007187417

## NON DTC RELATED ITEM

| Detected items                     | Engine operating condition in fail-safe mode                       | Remarks   | Reference page                                 |
|------------------------------------|--|---|--|
| Malfunction indicator lamp circuit | Engine speed will not rise more than 2,500 rpm due to the fuel cut | When there is an open circuit on MIL circuit, the ECM cannot warn the driver by illuminating MIL when there is malfunction on engine control system.<br>Therefore, when electrical controlled throttle and part of ECM related diagnoses are continuously detected as NG for 5 trips, ECM warns the driver that engine control system malfunctions and MIL circuit is open by means of operating the fail-safe function.<br>The fail-safe function also operates when above diagnoses except MIL circuit are detected and demands the driver to repair the malfunction. | <a href="#">EC-1534, "Diagnosis Procedure"</a> |

## DTC RELATED ITEM

# ECM

< ECU DIAGNOSIS INFORMATION >

[VK56VD FOR USA AND CANADA]

| DTC No.  | Detected items                                       | Engine operating condition in fail-safe mode   |  | A           |  |   |              |   |              |                       |  |                  |
|--|--|--|--|-------------|--|---|--------------|---|--------------|-----------------------|--|------------------|
| U0113<br>U1003<br>U1024  | Can communication circuit                            | VVEL actuator motor relay is turned off, and VVEL value is become at a minimum angle. Engine speed will not rise more than 3,500 rpm due to the fuel cut.  |  | EC          |  |   |              |   |              |                       |  |                  |
| P0011<br>P0021   | Intake valve timing control                          | The signal is not energized to the intake valve timing control solenoid valve and the valve control does not function.   |  |             |  |   |              |   |              |                       |  |                  |
| P0014<br>P0024   | Exhaust valve timing control                         | The signal is not energized to the exhaust valve timing control magnet retarder and the magnet retarder control does not function.   |  | C           |  |   |              |   |              |                       |  |                  |
| P0087  | FRP control system                                   | <ul style="list-style-type: none"> <li>• Engine torque is limited.</li> <li>• VVEL value is maintained at a fixed angle.</li> </ul>  |  | D           |  |   |              |   |              |                       |  |                  |
| P0088  |  | Engine speed is limited.   |  |             |  |   |              |   |              |                       |  |                  |
| P008A  | Low fuel pressure control system                     | Engine torque is limited.  |  | E           |  |   |              |   |              |                       |  |                  |
| P0090  | FRP control system                                   | <ul style="list-style-type: none"> <li>• Engine torque is limited.</li> <li>• VVEL value is maintained at a fixed angle.</li> </ul>  |  |             |  |   |              |   |              |                       |  |                  |
| P0102<br>P0103<br>P010C<br>P010D   | Mass air flow sensor circuit                         | Engine speed will not rise more than 2,400 rpm due to the fuel cut.  |  | F           |  |   |              |   |              |                       |  |                  |
| P0117<br>P0118   | Engine coolant temperature sensor circuit            | <p>Engine coolant temperature will be determined by ECM based on the following condition. CONSULT displays the engine coolant temperature decided by ECM.</p> <table border="1" style="width: 100%; border-collapse: collapse;"> <thead> <tr> <th style="text-align: left;">Condition</th> <th style="text-align: center;">Engine coolant temperature decided (CONSULT display)</th> </tr> </thead> <tbody> <tr> <td style="vertical-align: top;">Just as ignition switch is turned ON or START</td> <td style="text-align: center;">40°C (104°F)</td> </tr> <tr> <td style="vertical-align: top;">Approx. 4 minutes or more after engine starting</td> <td style="text-align: center;">80°C (176°F)</td> </tr> <tr> <td style="vertical-align: top;">Except as shown above</td> <td style="text-align: center;">40 - 80°C (104 - 176°F)<br/>(Depends on the time)</td> </tr> </tbody> </table> <p>When the fail-safe system for engine coolant temperature sensor is activated, the cooling fan operates while engine is running.</p> |  | Condition   | Engine coolant temperature decided (CONSULT display) | Just as ignition switch is turned ON or START | 40°C (104°F) | Approx. 4 minutes or more after engine starting | 80°C (176°F) | Except as shown above | 40 - 80°C (104 - 176°F)<br>(Depends on the time) | G<br>H<br>I<br>J |
| Condition  | Engine coolant temperature decided (CONSULT display) |  |  |             |  |   |              |   |              |                       |  |                  |
| Just as ignition switch is turned ON or START  | 40°C (104°F)   |  |  |             |  |   |              |   |              |                       |  |                  |
| Approx. 4 minutes or more after engine starting  | 80°C (176°F)   |  |  |             |  |   |              |   |              |                       |  |                  |
| Except as shown above  | 40 - 80°C (104 - 176°F)<br>(Depends on the time)     |  |  |             |  |   |              |   |              |                       |  |                  |
| P0122<br>P0123<br>P0222<br>P0223<br>P0227<br>P0228<br>P1239<br>P2132<br>P2133<br>P2135 | Throttle position sensor                             | <p>The ECM controls the electric throttle control actuator in regulating the throttle opening in order for the idle position to be within +10 degrees.</p> <p>The ECM regulates the opening speed of the throttle valve to be slower than the normal condition.</p> <p>Therefore, the acceleration will be poor.</p>   |  | K<br>L<br>M |  |   |              |   |              |                       |  |                  |
| P0190  | FRP sensor   | <ul style="list-style-type: none"> <li>• Engine speed is limited.</li> <li>• High pressure fuel pump is activated at maximum discharge pressure.</li> </ul>  |  | N           |  |   |              |   |              |                       |  |                  |
| P0196<br>P0197<br>P0198  | Engine oil temperature sensor                        | Exhaust valve timing control does not function.  |  | O           |  |   |              |   |              |                       |  |                  |
| P0201<br>P0202<br>P0203<br>P0204<br>P0205<br>P0206<br>P0207<br>P0208                   | Injector   | <ul style="list-style-type: none"> <li>• Engine torque is limited.</li> <li>• Fuel injection shut-off of malfunction cylinder.</li> <li>• Mixture ratio feedback control does not function.</li> <li>• Idle engine speed is increased.</li> </ul>  |  | P           |  |   |              |   |              |                       |  |                  |
| P0500  | Vehicle speed sensor                                 | The cooling fan operates (Highest) while engine is running.  |  |             |  |   |              |   |              |                       |  |                  |

# ECM

< ECU DIAGNOSIS INFORMATION >

[VK56VD FOR USA AND CANADA]

| DTC No.                 | Detected items                     | Engine operating condition in fail-safe mode   |
|-------------------------|------------------------------------|--|
| P0524                   | Engine oil pressure                | The signal is not energized to the intake valve timing control solenoid valve and the valve control does not function.<br>Engine speed will not rise more than 2,400 rpm due to the fuel cut.  |
| P0605                   | ECM                                | (When ECM calculation function is malfunctioning:)<br>ECM stops the electric throttle control actuator control, throttle valve is maintained at a fixed opening (approx. 5 degrees) by the return spring.<br>ECM deactivates ASCD operation.   |
| P0607                   | ECM                                | VVEL actuator motor relay is turned off, and VVEL value is become at a minimum angle.<br>Engine speed will not rise more than 3,500 rpm due to the fuel cut.   |
| P062B                   | ECM                                | Type1<br><ul style="list-style-type: none"> <li>• Engine torque is limited.</li> <li>• Idle engine speed is increased.</li> <li>• Fuel injector power supply shut-off.</li> <li>• High fuel pressure limitation.</li> </ul> Type2<br><ul style="list-style-type: none"> <li>• Engine torque is limited.</li> <li>• Fuel injection shut-off of malfunction cylinder.</li> <li>• Mixture ratio feedback control does not function.</li> <li>• Idle engine speed is increased.</li> </ul>   |
| P0643                   | Sensor power supply                | ECM stops the electric throttle control actuator control, throttle valve is maintained at a fixed opening (approx. 5 degrees) by the return spring.  |
| P1087<br>P1088          | VVEL control function              | VVEL of normal bank is controlled at VVEL angle of abnormal bank.<br>Engine speed will not rise more than 3,500 rpm due to the fuel cut.   |
| P1089<br>P1092          | VVEL control shaft position sensor | VVEL value is maintained at a fixed angle.<br>Engine speed will not rise more than 3,500 rpm due to the fuel cut   |
| P1608                   | VVEL control shaft position sensor | VVEL actuator motor relay is turned off, and VVEL value is become at a minimum angle.<br>Engine speed will not rise more than 3,500 rpm due to the fuel cut.   |
| P1090<br>P1093          | VVEL actuator motor                | VVEL of normal bank is controlled at VVEL angle of abnormal bank.<br>Engine speed will not rise more than 3,500 rpm due to the fuel cut.<br>VVEL actuator motor relay is turned off, and VVEL value is become at a minimum angle.<br>Engine speed will not rise more than 3,500 rpm due to the fuel cut.   |
| P1091                   | VVEL actuator motor relay          | VVEL actuator motor relay is turned off, and VVEL value is become at a minimum angle.<br>Engine speed will not rise more than 3,500 rpm due to the fuel cut.   |
| P1197                   | Out of gas                         | <ul style="list-style-type: none"> <li>• Engine torque is limited.</li> <li>• VVEL value is maintained at a fixed angle.</li> </ul>  |
| P1233<br>P2101          | Electric throttle control function | ECM stops the electric throttle control actuator control, throttle valve is maintained at a fixed opening (approx. 5 degrees) by the return spring.  |
| P1236<br>P2118          | Throttle control motor             | ECM stops the electric throttle control actuator control, throttle valve is maintained at a fixed opening (approx. 5 degrees) by the return spring.  |
| P1238<br>P2119          | Electric throttle control actuator | (When electric throttle control actuator does not function properly due to the return spring malfunction:)<br>ECM controls the electric throttle actuator by regulating the throttle opening around the idle position. The engine speed will not rise more than 2,000 rpm.<br>(When throttle valve opening angle in fail-safe mode is not in specified range:)<br>ECM controls the electric throttle control actuator because of regulating the throttle opening to 20 degrees or less.<br>(When ECM detects the throttle valve is stuck open:)<br>While the vehicle is being driven, it slows down gradually by fuel cut. After the vehicle stops, the engine stalls.<br>The engine can restart in the N or P position, and engine speed will not exceed 1,000 rpm or more. |
| P1290<br>P2100<br>P2103 | Throttle control motor relay       | ECM stops the electric throttle control actuator control, throttle valve is maintained at a fixed opening (approx. 5 degrees) by the return spring.  |
| P1606                   | VVEL control module                | VVEL actuator motor relay is turned off, and VVEL value is become at a minimum angle.<br>Engine speed will not rise more than 3,500 rpm due to the fuel cut.   |



# ECM

< ECU DIAGNOSIS INFORMATION >

[VK56VD FOR USA AND CANADA]

| DTC No.                                   | Detected items                    | Engine operating condition in fail-safe mode  |                   |
|---|-----------------------------------|---|-------------------|
| P1805                                     | Brake switch                      | ECM controls the electric throttle control actuator by regulating the throttle opening to a small range.<br>Therefore, acceleration will be poor.   |                   |
|   |                                   | Vehicle condition   | Driving condition |
|   |                                   | When engine is idling   | Normal            |
|   |                                   | When accelerating   | Poor acceleration |
| P2122<br>P2123<br>P2127<br>P2128<br>P2138 | Accelerator pedal position sensor | The ECM controls the electric throttle control actuator in regulating the throttle opening in order for the idle position to be within +10 degrees.<br>The ECM regulates the opening speed of the throttle valve to be slower than the normal condition.<br>Therefore, the acceleration will be poor. |                   |
| P2539                                     | Low fuel pressure sensor          | Engine torque is limited.   |                   |

## DTC Inspection Priority Chart

INFOID:000000007187418

If some DTCs are displayed at the same time, perform inspections one by one based on the following priority chart.

A  
EC  
C  
D  
E  
F  
G  
H  
I  
J  
K  
L  
M  
N  
O  
P

| Priority | Detected items (DTC)   |
|----------|--|
| 1        | <ul style="list-style-type: none"> <li>• U0101 CAN communication line</li> <li>• U0113 U1003 CAN communication line</li> <li>• U1001 CAN communication line</li> <li>• U1024 VVEL CAN communication line</li> <li>• P006A P0101 P0102 P0103 P010B P010C P010D Mass air flow sensor</li> <li>• P010A Manifold absolute pressure sensor</li> <li>• P0111 P0112 P0113 P0127 Intake air temperature sensor</li> <li>• P0116 P0117 P0118 P0125 Engine coolant temperature sensor</li> <li>• P0122 P0123 P0222 P0223 P0227 P0228 P1225 P1226 P1234 P1235 P1239 P2132 P2133 P2135 Throttle position sensor</li> <li>• P0128 Thermostat function</li> <li>• P0181 P0182 P0183 Fuel tank temperature sensor</li> <li>• P0196 P0197 P0198 Engine oil temperature sensor</li> <li>• P0327 P0328 P0332 P0333 Knock sensor</li> <li>• P0335 Crankshaft position sensor</li> <li>• P0340 P0345 Camshaft position sensor</li> <li>• P0460 P0461 P0462 P0463 Fuel level sensor</li> <li>• P0500 Vehicle speed sensor</li> <li>• P0520 EOP sensor</li> <li>• P0605 P0607 P0611 P062B ECM</li> <li>• P0643 Sensor power supply</li> <li>• P0700 TCM</li> <li>• P0705 P0850 Transmission range switch</li> <li>• P1089 P1092 P1608 VVEL control shaft position sensor</li> <li>• P1197 Out of gas*</li> <li>• P1220 Fuel pump control module (FPCM)</li> <li>• P1423 P1424 Cold start control</li> <li>• P1550 P1551 P1552 P1553 P1554 Battery current sensor</li> <li>• P1556 P1557 Battery temperature sensor</li> <li>• P1606 P1607 VVEL control module</li> <li>• P1610 - P1615 NATS</li> <li>• P1806 Brake booster pressure sensor</li> <li>• P2122 P2123 P2127 P2128 P2138 Accelerator pedal position sensor</li> <li>• P2539 P2541 P2542 Low fuel pressure sensor</li> </ul> |

# ECM

< ECU DIAGNOSIS INFORMATION >

[VK56VD FOR USA AND CANADA]

| Priority | Detected items (DTC)  |                                       |
|----------|---|---------------------------------------|
| 2        | <ul style="list-style-type: none"> <li>• P0031 P0032 P0051 P0052 Air fuel ratio (A/F) sensor 1 heater</li> <li>• P0037 P0038 P0057 P0058 Heated oxygen sensor 2 heater</li> <li>• P0075 P0081 Intake valve timing control solenoid valve</li> <li>• P0078 P0084 Exhaust valve timing control solenoid valve</li> <li>• P0090 High pressure fuel pump</li> <li>• P0130 P0131 P0132 P0133 P0150 P0151 P0152 P0153 P2A00 P2A03 Air fuel ratio (A/F) sensor 1</li> <li>• P0137 P0138 P0139 P0157 P0158 P0159 Heated oxygen sensor 2</li> <li>• P0190 - P0193 FRP sensor</li> <li>• P0441 EVAP control system purge flow monitoring</li> <li>• P0443 P0444 P0445 EVAP canister purge volume control solenoid valve</li> <li>• P0447 P0448 EVAP canister vent control valve</li> <li>• P0451 P0452 P0453 EVAP control system pressure sensor</li> <li>• P0550 Power steering pressure sensor</li> <li>• P0603 ECM power supply</li> <li>• P0710 P0717 P0720 P0729 P0730 P0731 P0732 P0733 P0734 P0735 P0740 P0744 P0745 P0750 P0775 P0780 P0795 P1730 P1734 P2713 P2722 P2731 P2807 A/T related sensors, solenoid valves and switches</li> <li>• P1078 P1084 Exhaust valve timing control position sensor</li> <li>• P1087 P1088 VVEL system</li> <li>• P1090 P1093 VVEL actuator motor</li> <li>• P1091 VVEL actuator motor relay</li> <li>• P1217 Engine over temperature (OVERHEAT)</li> <li>• P1233 P2101 Electric throttle control function</li> <li>• P1236 P2118 Throttle control motor</li> <li>• P1805 Brake switch</li> <li>• P2100 P2103 Throttle control motor relay</li> <li>• P2101 Electric throttle control function</li> </ul> | A<br>EC<br>C<br>D<br>E<br>F<br>G<br>H |
| 3        | <ul style="list-style-type: none"> <li>• P0011 P0021 Intake valve timing control</li> <li>• P0014 P0024 Exhaust valve timing control</li> <li>• P0087, P0088 FRP control system</li> <li>• P008A Low fuel pressure control system</li> <li>• P008B Low fuel pressure control system</li> <li>• P0106 Manifold absolute pressure sensor</li> <li>• P0171 P0172 P0174 P0175 Fuel injection system function</li> <li>• P0201 - P0208 Injector</li> <li>• P0300 - P0308 Misfire</li> <li>• P0420 P0430 Three way catalyst function</li> <li>• P0456 EVAP control system (VERY SMALL LEAK)</li> <li>• P0506 P0507 Idle speed control system</li> <li>• P050A P050B P050E Cold start control</li> <li>• P0524 Engine oil pressure</li> <li>• P100A P100B VVEL system</li> <li>• P1148 P1168 Closed loop control</li> <li>• P1212 TCS communication line</li> <li>• P1238 P2119 Electric throttle control actuator</li> <li>• P1564 ASCD steering switch / ICC steering switch</li> <li>• P1568 ICC command value</li> <li>• P1572 ASCD brake switch / ICC brake switch</li> <li>• P1574 ASCD vehicle speed sensor / ICC vehicle speed sensor</li> <li>• P1715 Input speed sensor</li> </ul>   | I<br>J<br>K<br>L<br>M<br>N            |

**NOTE:**

\*: If "P1197" is displayed with other DTC in priority 1, perform trouble diagnosis for "P1197" first.

## DTC Index

INFOID:000000007187419

×: Applicable —: Not applicable

| DTC*1            |       | Items<br>(CONSULT screen terms) | SRT<br>code | Trip | MIL | Permanent<br>DTC group*4 | Reference<br>page       |
|------------------|-------|---------------------------------|-------------|------|-----|--------------------------|-------------------------|
| CONSULT<br>GST*2 | ECM*3 |                                 |             |      |     |                          |                         |
| U0101            | 0101  | LOST COMM (TCM)                 | —           | 1    | ×   | B                        | <a href="#">EC-1153</a> |
| U0113            | 0113  | CAN COMM CIRCUIT                | —           | 1    | ×   | B                        | <a href="#">EC-1154</a> |

# ECM

< ECU DIAGNOSIS INFORMATION >

[VK56VD FOR USA AND CANADA]

| DTC*1            |             | Items<br>(CONSULT screen terms)                                     | SRT<br>code | Trip  | MIL               | Permanent<br>DTC group*4 | Reference<br>page       |
|------------------|-------------|---|-------------|---|-------------------|--------------------------|-------------------------|
| CONSULT<br>GST*2 | ECM*3       |   |             |   |                   |                          |                         |
| U1001            | 1001*4      | CAN COMM CIRCUIT  | —           | 2<br>(with AS-<br>CD)<br>1 or 2<br>(with ICC) | —                 | B                        | <a href="#">EC-1156</a> |
| U1003            | 1003        | CAN COMM CIRCUIT  | —           | 2   | —                 | —                        | <a href="#">EC-1154</a> |
| U1024            | 1024        | VVEL CAN COMM CIRCUIT   | —           | 1   | ×                 | B                        | <a href="#">EC-1157</a> |
| <b>P0000</b>     | <b>0000</b> | <b>NO DTC IS DETECTED.<br/>FURTHER TESTING<br/>MAY BE REQUIRED.</b> | —           | —   | <b>Blinking*7</b> | —                        | —                       |
| P0011            | 0011        | INT/V TIM CONT-B1   | ×           | 2   | ×                 | B                        | <a href="#">EC-1165</a> |
| P0014            | 0014        | EXH/V TIM CONT-B1   | —           | 2   | ×                 | B                        | <a href="#">EC-1169</a> |
| P0021            | 0021        | INT/V TIM CONT-B2   | ×           | 2   | ×                 | B                        | <a href="#">EC-1165</a> |
| P0024            | 0024        | EXH/V TIM CONT-B2   | —           | 2   | ×                 | B                        | <a href="#">EC-1169</a> |
| P0031            | 0031        | A/F SEN1 HTR (B1)   | —           | 2   | ×                 | B                        | <a href="#">EC-1173</a> |
| P0032            | 0032        | A/F SEN1 HTR (B1)   | —           | 2   | ×                 | B                        | <a href="#">EC-1173</a> |
| P0037            | 0037        | HO2S2 HTR (B1)  | —           | 2   | ×                 | B                        | <a href="#">EC-1176</a> |
| P0038            | 0038        | HO2S2 HTR (B1)  | —           | 2   | ×                 | B                        | <a href="#">EC-1176</a> |
| P0051            | 0051        | A/F SEN1 HTR (B2)   | —           | 2   | ×                 | B                        | <a href="#">EC-1173</a> |
| P0052            | 0052        | A/F SEN1 HTR (B2)   | —           | 2   | ×                 | B                        | <a href="#">EC-1173</a> |
| P0057            | 0057        | HO2S2 HTR (B2)  | —           | 2   | ×                 | B                        | <a href="#">EC-1176</a> |
| P0058            | 0058        | HO2S2 HTR (B2)  | —           | 2   | ×                 | B                        | <a href="#">EC-1176</a> |
| P006A            | 006A        | MAP-MAF CORELTION-B1  | —           | 2   | ×                 | B                        | <a href="#">EC-1159</a> |
| P0075            | 0075        | INT/V TIM V/CIR-B1  | —           | 2   | ×                 | B                        | <a href="#">EC-1179</a> |
| P0078            | 0078        | EX V/T ACT/CIRC-B1  | —           | 2   | ×                 | B                        | <a href="#">EC-1182</a> |
| P0081            | 0081        | INT/V TIM V/CIR-B2  | —           | 2   | ×                 | B                        | <a href="#">EC-1179</a> |
| P0084            | 0084        | EX V/T ACT/CIRC-B2  | —           | 2   | ×                 | B                        | <a href="#">EC-1182</a> |
| P0087            | 0087        | LOW FUEL PRES   | —           | 2   | ×                 | B                        | <a href="#">EC-1188</a> |
| P0088            | 0088        | HIGH FUEL PRES  | —           | 2   | ×                 | B                        | <a href="#">EC-1192</a> |
| P008A            | 008A        | LOW FUEL PRES SYS   | —           | 2   | ×                 | B                        | <a href="#">EC-1185</a> |
| P008B            | 008B        | LOW FUEL PRES SYS   | —           | 2   | ×                 | B                        | <a href="#">EC-1187</a> |
| P0090            | 0090        | FUEL PUMP   | —           | 2   | ×                 | B                        | <a href="#">EC-1195</a> |
| P0101            | 0101        | MAF SEN/CIRCUIT-B1  | —           | 2   | ×                 | B                        | <a href="#">EC-1159</a> |
| P0102            | 0102        | MAF SEN/CIRCUIT-B1  | —           | 1   | ×                 | B                        | <a href="#">EC-1198</a> |
| P0103            | 0103        | MAF SEN/CIRCUIT-B1  | —           | 1   | ×                 | B                        | <a href="#">EC-1198</a> |
| P0106            | 0106        | ABSL PRES SEN/CIRC  | —           | 2   | ×                 | B                        | <a href="#">EC-1204</a> |
| P010A            | 010A        | ABSL PRES SEN/CIRC  | —           | 2   | ×                 | B                        | <a href="#">EC-1208</a> |
| P010B            | 010B        | MAF SEN/CIRCUIT-B2  | —           | 2   | ×                 | B                        | <a href="#">EC-1159</a> |
| P010C            | 010C        | MAF SEN/CIRCUIT-B2  | —           | 1   | ×                 | B                        | <a href="#">EC-1198</a> |
| P010D            | 010D        | MAF SEN/CIRCUIT-B2  | —           | 1   | ×                 | B                        | <a href="#">EC-1198</a> |
| P0111            | 0111        | IAT SENSOR 1 B1   | —           | 2   | ×                 | A                        | <a href="#">EC-1211</a> |
| P0112            | 0112        | IAT SEN/CIRCUIT-B1  | —           | 2   | ×                 | B                        | <a href="#">EC-1213</a> |
| P0113            | 0113        | IAT SEN/CIRCUIT-B1  | —           | 2   | ×                 | B                        | <a href="#">EC-1213</a> |
| P0116            | 0116        | ECT SEN/CIRC  | —           | 2   | ×                 | A                        | <a href="#">EC-1215</a> |

# ECM

< ECU DIAGNOSIS INFORMATION >

[VK56VD FOR USA AND CANADA]

| DTC*1            |       | Items<br>(CONSULT screen terms) | SRT<br>code | Trip | MIL | Permanent<br>DTC group*4 | Reference<br>page       |
|------------------|-------|---------------------------------|-------------|------|-----|--------------------------|-------------------------|
| CONSULT<br>GST*2 | ECM*3 |                                 |             |      |     |                          |                         |
| P0117            | 0117  | ECT SEN/CIRC                    | —           | 1    | ×   | B                        | <a href="#">EC-1218</a> |
| P0118            | 0118  | ECT SEN/CIRC                    | —           | 1    | ×   | B                        | <a href="#">EC-1218</a> |
| P0122            | 0122  | TP SEN 2/CIRC-B1                | —           | 1    | ×   | B                        | <a href="#">EC-1220</a> |
| P0123            | 0123  | TP SEN 2/CIRC-B1                | —           | 1    | ×   | B                        | <a href="#">EC-1220</a> |
| P0125            | 0125  | ECT SENSOR                      | —           | 2    | ×   | B                        | <a href="#">EC-1223</a> |
| P0127            | 0127  | IAT SENSOR-B1                   | —           | 2    | ×   | B                        | <a href="#">EC-1225</a> |
| P0128            | 0128  | THERMSTAT FNCTN                 | —           | 2    | ×   | B                        | <a href="#">EC-1227</a> |
| P0130            | 0130  | A/F SENSOR1 (B1)                | ×           | 2    | ×   | A                        | <a href="#">EC-1229</a> |
| P0131            | 0131  | A/F SENSOR1 (B1)                | —           | 2    | ×   | B                        | <a href="#">EC-1233</a> |
| P0132            | 0132  | A/F SENSOR1 (B1)                | —           | 2    | ×   | B                        | <a href="#">EC-1236</a> |
| P0133            | 0133  | A/F SENSOR1 (B1)                | ×           | 2    | ×   | A                        | <a href="#">EC-1239</a> |
| P0137            | 0137  | HO2S2 (B1)                      | ×           | 2    | ×   | A                        | <a href="#">EC-1244</a> |
| P0138            | 0138  | HO2S2 (B1)                      | ×           | 2    | ×   | A                        | <a href="#">EC-1250</a> |
| P0139            | 0139  | HO2S2 (B1)                      | ×           | 2    | ×   | A                        | <a href="#">EC-1258</a> |
| P0150            | 0150  | A/F SENSOR1 (B2)                | ×           | 2    | ×   | A                        | <a href="#">EC-1229</a> |
| P0151            | 0151  | A/F SENSOR1 (B2)                | —           | 2    | ×   | B                        | <a href="#">EC-1233</a> |
| P0152            | 0152  | A/F SENSOR1 (B2)                | —           | 2    | ×   | B                        | <a href="#">EC-1236</a> |
| P0153            | 0153  | A/F SENSOR1 (B2)                | ×           | 2    | ×   | A                        | <a href="#">EC-1239</a> |
| P0157            | 0157  | HO2S2 (B2)                      | ×           | 2    | ×   | A                        | <a href="#">EC-1244</a> |
| P0158            | 0158  | HO2S2 (B2)                      | ×           | 2    | ×   | A                        | <a href="#">EC-1250</a> |
| P0159            | 0159  | HO2S2 (B2)                      | ×           | 2    | ×   | A                        | <a href="#">EC-1258</a> |
| P0171            | 0171  | FUEL SYS-LEAN-B1                | —           | 2    | ×   | B                        | <a href="#">EC-1264</a> |
| P0172            | 0172  | FUEL SYS-RICH-B1                | —           | 2    | ×   | B                        | <a href="#">EC-1268</a> |
| P0174            | 0174  | FUEL SYS-LEAN-B2                | —           | 2    | ×   | B                        | <a href="#">EC-1264</a> |
| P0175            | 0175  | FUEL SYS-RICH-B2                | —           | 2    | ×   | B                        | <a href="#">EC-1268</a> |
| P0181            | 0181  | FTT SENSOR                      | —           | 2    | ×   | A and B                  | <a href="#">EC-1272</a> |
| P0182            | 0182  | FTT SEN/CIRCUIT                 | —           | 2    | ×   | B                        | <a href="#">EC-1276</a> |
| P0183            | 0183  | FTT SEN/CIRCUIT                 | —           | 2    | ×   | B                        | <a href="#">EC-1276</a> |
| P0190            | 0190  | FUEL PRES SEN/CIRC              | —           | 1    | ×   | B                        | <a href="#">EC-1279</a> |
| P0191            | 0191  | FRP SENSOR A                    | —           | 2    | ×   | A                        | <a href="#">EC-1279</a> |
| P0192            | 0192  | FRP SEN/CIRC                    | —           | 2    | ×   | B                        | <a href="#">EC-1279</a> |
| P0193            | 0193  | FRP SEN/CIRC                    | —           | 2    | ×   | B                        | <a href="#">EC-1279</a> |
| P0196            | 0196  | EOT SENSOR                      | —           | 2    | ×   | A and B                  | <a href="#">EC-1287</a> |
| P0197            | 0197  | EOT SEN/CIRC                    | —           | 2    | ×   | B                        | <a href="#">EC-1291</a> |
| P0198            | 0198  | EOT SEN/CIRC                    | —           | 2    | ×   | B                        | <a href="#">EC-1291</a> |
| P0201            | 0201  | INJECTOR CIRC-CYL1              | —           | 2    | ×   | B                        | <a href="#">EC-1293</a> |
| P0202            | 0202  | INJECTOR CIRC-CYL2              | —           | 2    | ×   | B                        | <a href="#">EC-1293</a> |
| P0203            | 0203  | INJECTOR CIRC-CYL3              | —           | 2    | ×   | B                        | <a href="#">EC-1293</a> |
| P0204            | 0204  | INJECTOR CIRC-CYL4              | —           | 2    | ×   | B                        | <a href="#">EC-1293</a> |
| P0205            | 0205  | INJECTOR CIRC-CYL5              | —           | 2    | ×   | B                        | <a href="#">EC-1293</a> |
| P0206            | 0206  | INJECTOR CIRC-CYL6              | —           | 2    | ×   | B                        | <a href="#">EC-1293</a> |
| P0207            | 0207  | INJECTOR CIRC-CYL7              | —           | 2    | ×   | B                        | <a href="#">EC-1293</a> |

A

EC

C

D

E

F

G

H

I

J

K

L

M

N

O

P

# ECM

< ECU DIAGNOSIS INFORMATION >

[VK56VD FOR USA AND CANADA]

| DTC*1            |       | Items<br>(CONSULT screen terms) | SRT<br>code | Trip   | MIL | Permanent<br>DTC group*4 | Reference<br>page       |
|------------------|-------|---------------------------------|-------------|--------|-----|--------------------------|-------------------------|
| CONSULT<br>GST*2 | ECM*3 |                                 |             |        |     |                          |                         |
| P0208            | 0208  | INJECTOR CIRC-CYL8              | —           | 2      | ×   | B                        | <a href="#">EC-1293</a> |
| P0222            | 0222  | TP SEN 1/CIRC-B1                | —           | 1      | ×   | B                        | <a href="#">EC-1294</a> |
| P0223            | 0223  | TP SEN 1/CIRC-B1                | —           | 1      | ×   | B                        | <a href="#">EC-1294</a> |
| P0227            | 0227  | TP SEN 2/CIRC-B2                | —           | 1      | ×   | B                        | <a href="#">EC-1220</a> |
| P0228            | 0228  | TP SEN 2/CIRC-B2                | —           | 1      | ×   | B                        | <a href="#">EC-1220</a> |
| P0300            | 0300  | MULTI CYL MISFIRE               | —           | 1 or 2 | ×   | B                        | <a href="#">EC-1297</a> |
| P0301            | 0301  | CYL 1 MISFIRE                   | —           | 1 or 2 | ×   | B                        | <a href="#">EC-1297</a> |
| P0302            | 0302  | CYL 2 MISFIRE                   | —           | 1 or 2 | ×   | B                        | <a href="#">EC-1297</a> |
| P0303            | 0303  | CYL 3 MISFIRE                   | —           | 1 or 2 | ×   | B                        | <a href="#">EC-1297</a> |
| P0304            | 0304  | CYL 4 MISFIRE                   | —           | 1 or 2 | ×   | B                        | <a href="#">EC-1297</a> |
| P0305            | 0305  | CYL 5 MISFIRE                   | —           | 1 or 2 | ×   | B                        | <a href="#">EC-1297</a> |
| P0306            | 0306  | CYL 6 MISFIRE                   | —           | 1 or 2 | ×   | B                        | <a href="#">EC-1297</a> |
| P0307            | 0307  | CYL 7 MISFIRE                   | —           | 1 or 2 | ×   | B                        | <a href="#">EC-1297</a> |
| P0308            | 0308  | CYL 8 MISFIRE                   | —           | 1 or 2 | ×   | B                        | <a href="#">EC-1297</a> |
| P0327            | 0327  | KNOCK SEN/CIRC-B1               | —           | 2      | ×   | —                        | <a href="#">EC-1303</a> |
| P0328            | 0328  | KNOCK SEN/CIRC-B1               | —           | 2      | ×   | —                        | <a href="#">EC-1303</a> |
| P0332            | 0332  | KNOCK SEN/CIRC-B2               | —           | 2      | ×   | B                        | <a href="#">EC-1303</a> |
| P0333            | 0333  | KNOCK SEN/CIRC-B2               | —           | 2      | ×   | B                        | <a href="#">EC-1303</a> |
| P0335            | 0335  | CKP SEN/CIRCUIT                 | —           | 2      | ×   | B                        | <a href="#">EC-1305</a> |
| P0340            | 0340  | CMP SEN/CIRC-B1                 | —           | 2      | ×   | B                        | <a href="#">EC-1309</a> |
| P0345            | 0345  | CMP SEN/CIRC-B2                 | —           | 2      | ×   | B                        | <a href="#">EC-1309</a> |
| P0420            | 0420  | TW CATALYST SYS-B1              | ×           | 2      | ×   | A                        | <a href="#">EC-1314</a> |
| P0430            | 0430  | TW CATALYST SYS-B2              | ×           | 2      | ×   | A                        | <a href="#">EC-1314</a> |
| P0441            | 0441  | EVAP PURG FLOW/MON              | ×           | 2      | ×   | A                        | <a href="#">EC-1319</a> |
| P0443            | 0443  | PURG VOLUME CONT/V              | —           | 2      | ×   | A                        | <a href="#">EC-1324</a> |
| P0444            | 0444  | PURG VOLUME CONT/V              | —           | 2      | ×   | B                        | <a href="#">EC-1329</a> |
| P0445            | 0445  | PURG VOLUME CONT/V              | —           | 2      | ×   | B                        | <a href="#">EC-1329</a> |
| P0447            | 0447  | VENT CONTROL VALVE              | —           | 2      | ×   | B                        | <a href="#">EC-1332</a> |
| P0448            | 0448  | VENT CONTROL VALVE              | —           | 2      | ×   | B                        | <a href="#">EC-1336</a> |
| P0451            | 0451  | EVAP SYS PRES SEN               | —           | 2      | ×   | A                        | <a href="#">EC-1340</a> |
| P0452            | 0452  | EVAP SYS PRES SEN               | —           | 2      | ×   | B                        | <a href="#">EC-1344</a> |
| P0453            | 0453  | EVAP SYS PRES SEN               | —           | 2      | ×   | B                        | <a href="#">EC-1349</a> |
| P0456            | 0456  | EVAP VERY SML LEAK              | ×*6         | 2      | ×   | A                        | <a href="#">EC-1355</a> |
| P0460            | 0460  | FUEL LEV SEN SLOSH              | —           | 2      | ×   | A                        | <a href="#">EC-1361</a> |
| P0461            | 0461  | FUEL LEVEL SENSOR               | —           | 2      | ×   | B                        | <a href="#">EC-1362</a> |
| P0462            | 0462  | FUEL LEVL SEN/CIRC              | —           | 2      | ×   | B                        | <a href="#">EC-1364</a> |
| P0463            | 0463  | FUEL LEVL SEN/CIRC              | —           | 2      | ×   | B                        | <a href="#">EC-1364</a> |
| P0500            | 0500  | VEHICLE SPEED SEN A*5           | —           | 2      | ×   | B                        | <a href="#">EC-1365</a> |
| P0506            | 0506  | ISC SYSTEM                      | —           | 2      | ×   | B                        | <a href="#">EC-1367</a> |
| P0507            | 0507  | ISC SYSTEM                      | —           | 2      | ×   | B                        | <a href="#">EC-1369</a> |
| P050A            | 050A  | COLD START CONTROL              | —           | 2      | ×   | A                        | <a href="#">EC-1371</a> |
| P050B            | 050B  | COLD START CONTROL              | —           | 2      | ×   | A                        | <a href="#">EC-1371</a> |

# ECM

< ECU DIAGNOSIS INFORMATION >

[VK56VD FOR USA AND CANADA]

| DTC*1            |       | Items<br>(CONSULT screen terms) | SRT<br>code | Trip   | MIL    | Permanent<br>DTC group*4 | Reference<br>page       |
|------------------|-------|---------------------------------|-------------|--------|--------|--------------------------|-------------------------|
| CONSULT<br>GST*2 | ECM*3 |                                 |             |        |        |                          |                         |
| P050E            | 050E  | COLD START CONTROL              | —           | 2      | ×      | A                        | <a href="#">EC-1371</a> |
| P0520            | 0520  | EOP SENSOR/SWITCH               | —           | 1      | —      | B                        | <a href="#">EC-1373</a> |
| P0524            | 0524  | ENGINE OIL PRESSURE             | —           | 2      | ×      | B                        | <a href="#">EC-1376</a> |
| P0550            | 0550  | PW ST P SEN/CIRC                | —           | 2      | —      | B                        | <a href="#">EC-1379</a> |
| P0603            | 0603  | ECM BACK UP/CIRCUIT             | —           | 2      | ×      | B                        | <a href="#">EC-1382</a> |
| P0605            | 0605  | ECM                             | —           | 1 or 2 | × or — | B                        | <a href="#">EC-1384</a> |
| P0607            | 0607  | ECM                             | —           | 1      | ×      | B                        | <a href="#">EC-1386</a> |
| P0611            | 0611  | FIC MODULE                      | —           | 2      | ×      | —                        | <a href="#">EC-1387</a> |
| P062B            | 062B  | ECM                             | —           | 2      | × or — | B                        | <a href="#">EC-1388</a> |
| P0643            | 0643  | SENSOR POWER/CIRC               | —           | 1      | ×      | B                        | <a href="#">EC-1389</a> |
| P0705            | 0705  | T/M RANGE SENSOR A              | —           | 2      | ×      | B                        | <a href="#">TM-102</a>  |
| P0710            | 0710  | FLUID TEMP SENSOR A*8           | —           | 2      | ×      | B                        | <a href="#">TM-103</a>  |
| P0717            | 0717  | INPUT SPEED SENSOR A            | —           | 2      | ×      | B                        | <a href="#">TM-105</a>  |
| P0720            | 0720  | OUTPUT SPEED SENSOR*5           | —           | 2      | ×      | B                        | <a href="#">TM-106</a>  |
| P0729            | 0729  | 6GR INCORRECT RATIO*8           | —           | 2      | ×      | B                        | <a href="#">TM-110</a>  |
| P0730            | 0730  | INCORRECT GR RATIO              | —           | 2      | ×      | B                        | <a href="#">TM-112</a>  |
| P0731            | 0731  | 1GR INCORRECT RATIO*8           | —           | 2      | ×      | B                        | <a href="#">TM-114</a>  |
| P0732            | 0732  | 2GR INCORRECT RATIO*8           | —           | 2      | ×      | B                        | <a href="#">TM-116</a>  |
| P0733            | 0733  | 3GR INCORRECT RATIO*8           | —           | 2      | ×      | B                        | <a href="#">TM-118</a>  |
| P0734            | 0734  | 4GR INCORRECT RATIO*8           | —           | 2      | ×      | B                        | <a href="#">TM-120</a>  |
| P0735            | 0735  | 5GR INCORRECT RATIO*8           | —           | 2      | ×      | B                        | <a href="#">TM-122</a>  |
| P0740            | 0740  | TORQUE CONVERTER                | —           | 2      | ×      | B                        | <a href="#">TM-124</a>  |
| P0744            | 0744  | TORQUE CONVERTER                | —           | 2      | ×      | B                        | <a href="#">TM-125</a>  |
| P0745            | 0745  | PC SOLENOID A                   | —           | 2      | ×      | B                        | <a href="#">TM-127</a>  |
| P0750            | 0750  | SHIFT SOLENOID A                | —           | 2      | ×      | B                        | <a href="#">TM-128</a>  |
| P0775            | 0775  | PC SOLENOID B                   | —           | 2      | ×      | B                        | <a href="#">TM-129</a>  |
| P0780            | 0780  | SHIFT                           | —           | 1      | ×      | B                        | <a href="#">TM-130</a>  |
| P0795            | 0795  | PC SOLENOID C                   | —           | 2      | ×      | B                        | <a href="#">TM-132</a>  |
| P0850            | 0850  | P-N POS SW/CIRCUIT              | —           | 2      | ×      | B                        | <a href="#">EC-1391</a> |
| P100A            | 100A  | VVEL SYSTEM-B1                  | —           | 2      | ×      | B                        | <a href="#">EC-1394</a> |
| P100B            | 100B  | VVEL SYSTEM-B2                  | —           | 2      | ×      | B                        | <a href="#">EC-1394</a> |
| P1078            | 1078  | EXH TIM SEN/CIRC-B1             | —           | 2      | ×      | B                        | <a href="#">EC-1398</a> |
| P1084            | 1084  | EXH TIM SEN/CIRC-B2             | —           | 2      | ×      | B                        | <a href="#">EC-1398</a> |
| P1087            | 1087  | VVEL SYSTEM-B1                  | —           | 1      | ×      | B                        | <a href="#">EC-1401</a> |
| P1088            | 1088  | VVEL SYSTEM-B2                  | —           | 1      | ×      | B                        | <a href="#">EC-1401</a> |
| P1089            | 1089  | VVEL POS SEN/CIRC-B1            | —           | 1      | ×      | B                        | <a href="#">EC-1402</a> |
| P1090            | 1090  | VVEL ACTR MOT-B1                | —           | 1      | ×      | B                        | <a href="#">EC-1405</a> |
| P1091            | 1091  | VVEL ACTR MOT PWR               | —           | 1 or 2 | ×      | B                        | <a href="#">EC-1408</a> |
| P1092            | 1092  | VVEL POS SEN/CIRC-B2            | —           | 1      | ×      | B                        | <a href="#">EC-1402</a> |
| P1093            | 1093  | VVEL ACTR MOT-B2                | —           | 1      | ×      | B                        | <a href="#">EC-1405</a> |
| P1148            | 1148  | CLOSED LOOP-B1                  | —           | 1      | ×      | A                        | <a href="#">EC-1411</a> |

A

EC

C

D

E

F

G

H

I

J

K

L

M

N

O

P

# ECM

< ECU DIAGNOSIS INFORMATION >

[VK56VD FOR USA AND CANADA]

| DTC*1            |       | Items<br>(CONSULT screen terms) | SRT<br>code | Trip   | MIL    | Permanent<br>DTC group*4 | Reference<br>page   |
|------------------|-------|---------------------------------|-------------|--------|--------|--------------------------|---|
| CONSULT<br>GST*2 | ECM*3 |                                 |             |        |        |                          |   |
| P1168            | 1168  | CLOSED LOOP-B2                  | —           | 1      | ×      | A                        | <a href="#">EC-1411</a>   |
| P1197            | 1197  | FUEL RUN OUT                    | —           | 2      | —      | B                        | <a href="#">EC-1291</a>   |
| P1212            | 1212  | TCS/CIRC                        | —           | 2      | —      | B                        | <a href="#">EC-1414</a>   |
| P1217            | 1217  | ENG OVER TEMP                   | —           | 1      | ×      | B                        | <a href="#">EC-1415</a>   |
| P1220            | 1220  | FPCM                            | —           | 1      | —      | B                        | <a href="#">EC-1418</a>   |
| P1225            | 1225  | CTP LEARNING-B1                 | —           | 2      | —      | —                        | <a href="#">EC-1421</a>   |
| P1226            | 1226  | CTP LEARNING-B1                 | —           | 2      | —      | —                        | <a href="#">EC-1422</a>   |
| P1233            | 1233  | ETC FNCTN/CIRC-B2               | —           | 1      | ×      | B                        | <a href="#">EC-1423</a>   |
| P1234            | 1234  | CTP LEARNING-B2                 | —           | 2      | —      | B                        | <a href="#">EC-1421</a>   |
| P1235            | 1235  | CTP LEARNING-B2                 | —           | 2      | —      | B                        | <a href="#">EC-1422</a>   |
| P1236            | 1236  | ETC MOT-B2                      | —           | 1      | ×      | B                        | <a href="#">EC-1427</a>   |
| P1238            | 1238  | ETC ACTR-B2                     | —           | 1      | ×      | B                        | <a href="#">EC-1429</a>   |
| P1239            | 1239  | TP SENSOR-B2                    | —           | 1      | ×      | B                        | <a href="#">EC-1431</a>   |
| P1423            | 1423  | COLD START CONTROL              | —           | 2      | ×      | A                        | <a href="#">EC-1434</a>   |
| P1424            | 1424  | COLD START CONTROL              | —           | 2      | ×      | A                        | <a href="#">EC-1434</a>   |
| P1550            | 1550  | BAT CURRENT SENSOR              | —           | 2      | —      | B                        | <a href="#">EC-1436</a>   |
| P1551            | 1551  | BAT CURRENT SENSOR              | —           | 2      | —      | B                        | <a href="#">EC-1440</a>   |
| P1552            | 1552  | BAT CURRENT SENSOR              | —           | 2      | —      | B                        | <a href="#">EC-1440</a>   |
| P1553            | 1553  | BAT CURRENT SENSOR              | —           | 2      | —      | B                        | <a href="#">EC-1444</a>   |
| P1554            | 1554  | BAT CURRENT SENSOR              | —           | 2      | —      | B                        | <a href="#">EC-1448</a>   |
| P1556            | 1556  | BAT TMP SEN/CIRC                | —           | 2      | —      | —                        | <a href="#">EC-1452</a>   |
| P1557            | 1557  | BAT TMP SEN/CIRC                | —           | 2      | —      | —                        | <a href="#">EC-1452</a>   |
| P1564            | 1564  | ASCD SW                         | —           | 1      | —      | B                        | <a href="#">EC-1455</a><br>(with ASCD)<br><a href="#">EC-1458</a><br>(with ICC) |
| P1568            | 1568  | ICC COMMAND VALUE               | —           | 1      | —      | B                        | <a href="#">EC-1461</a>   |
| P1572            | 1572  | ASCD BRAKE SW                   | —           | 1      | —      | B                        | <a href="#">EC-1462</a><br>(with ASCD)<br><a href="#">EC-1467</a><br>(with ICC) |
| P1574            | 1574  | ASCD VHL SPD SEN                | —           | 1      | —      | B                        | <a href="#">EC-1473</a><br>(with ASCD)<br><a href="#">EC-1475</a><br>(with ICC) |
| P1606            | 1606  | VVEL CONTROL MODULE             | —           | 1 or 2 | × or — | B                        | <a href="#">EC-1477</a>   |
| P1607            | 1607  | VVEL CONTROL MODULE             | —           | 1      | ×      | B                        | <a href="#">EC-1478</a>   |
| P1608            | 1608  | VVEL SENSOR POWER/CIRC          | —           | 1      | ×      | B                        | <a href="#">EC-1479</a>   |
| P1610            | 1610  | LOCK MODE                       | —           | 2      | —      | —                        | <a href="#">SEC-41</a>  |
| P1611            | 1611  | ID DISCORD IMMU-ECM             | —           | 2      | —      | —                        | <a href="#">SEC-42</a>  |
| P1612            | 1612  | CHAIN OF ECM-IMMU               | —           | 2      | —      | —                        | <a href="#">SEC-43</a>  |
| P1614            | 1614  | CHAIN OF IMMU-KEY               | —           | 2      | —      | —                        | <a href="#">SEC-44</a>  |
| P1715            | 1715  | IN PULY SPEED                   | —           | 2      | —      | —                        | <a href="#">EC-1481</a>   |
| P1730            | 1730  | INTERLOCK                       | —           | 2      | ×      | —                        | <a href="#">TM-136</a>  |
| P1734            | 1734  | 7GR INCORRECT RATIO*8           | —           | 2      | ×      | —                        | <a href="#">TM-138</a>  |



# ECM

< ECU DIAGNOSIS INFORMATION >

[VK56VD FOR USA AND CANADA]

| DTC*1            |       | Items<br>(CONSULT screen terms) | SRT<br>code | Trip | MIL | Permanent<br>DTC group*4 | Reference<br>page       |
|------------------|-------|---------------------------------|-------------|------|-----|--------------------------|-------------------------|
| CONSULT<br>GST*2 | ECM*3 |                                 |             |      |     |                          |                         |
| P1805            | 1805  | BRAKE SW/CIRCUIT                | —           | 2    | —   | B                        | <a href="#">EC-1482</a> |
| P1806            | 1806  | BRAKE VACUUM SEN                | —           | 2    | ×   | B                        | <a href="#">BRC-111</a> |
| P2100            | 2100  | ETC MOT PWR-B1                  | —           | 1    | ×   | B                        | <a href="#">EC-1485</a> |
| P2101            | 2101  | ETC FNCTN/CIRC-B1               | —           | 1    | ×   | B                        | <a href="#">EC-1423</a> |
| P2103            | 2103  | ETC MOT PWR                     | —           | 1    | ×   | B                        | <a href="#">EC-1485</a> |
| P2118            | 2118  | ETC MOT-B1                      | —           | 1    | ×   | B                        | <a href="#">EC-1427</a> |
| P2119            | 2119  | ETC ACTR-B1                     | —           | 1    | ×   | B                        | <a href="#">EC-1429</a> |
| P2122            | 2122  | APP SEN 1/CIRC                  | —           | 1    | ×   | B                        | <a href="#">EC-1487</a> |
| P2123            | 2123  | APP SEN 1/CIRC                  | —           | 1    | ×   | B                        | <a href="#">EC-1487</a> |
| P2127            | 2127  | APP SEN 2/CIRC                  | —           | 1    | ×   | B                        | <a href="#">EC-1490</a> |
| P2128            | 2128  | APP SEN 2/CIRC                  | —           | 1    | ×   | B                        | <a href="#">EC-1490</a> |
| P2132            | 2132  | TP SEN 1/CIRC-B2                | —           | 1    | ×   | —                        | <a href="#">EC-1294</a> |
| P2133            | 2133  | TP SEN 1/CIRC-B2                | —           | 1    | ×   | —                        | <a href="#">EC-1294</a> |
| P2135            | 2135  | TP SENSOR-B1                    | —           | 1    | ×   | B                        | <a href="#">EC-1431</a> |
| P2138            | 2138  | APP SENSOR                      | —           | 1    | ×   | B                        | <a href="#">EC-1494</a> |
| P2539            | 2539  | LOW FUEL PRES SEN               | —           | 2    | ×   | B                        | <a href="#">EC-1499</a> |
| P2541            | 2541  | LOW FUEL PRES SEN               | —           | 2    | ×   | B                        | <a href="#">EC-1499</a> |
| P2542            | 2542  | LOW FUEL PRES SEN               | —           | 2    | ×   | B                        | <a href="#">EC-1499</a> |
| P2713            | 2713  | PC SOLENOID D                   | —           | 2    | ×   | —                        | <a href="#">TM-146</a>  |
| P2722            | 2722  | PC SOLENOID E                   | —           | 2    | ×   | —                        | <a href="#">TM-147</a>  |
| P2731            | 2731  | PC SOLENOID F                   | —           | 2    | ×   | —                        | <a href="#">TM-148</a>  |
| P2807            | 2807  | PC SOLENOID G                   | —           | 2    | ×   | —                        | <a href="#">TM-149</a>  |
| P2A00            | 2A00  | A/F SENSOR1 (B1)                | —           | 2    | ×   | A                        | <a href="#">EC-1503</a> |
| P2A03            | 2A03  | A/F SENSOR1 (B2)                | —           | 2    | ×   | A                        | <a href="#">EC-1503</a> |

\*1: 1st trip DTC No. is the same as DTC No.

\*2: This number is prescribed by SAE J2012/ISO 15031-6.

\*3: In Diagnostic Test Mode II (Self-diagnostic results), this number is controlled by NISSAN.

\*4: Refer to [EC-1136, "Description"](#).

\*5: The troubleshooting for this DTC needs CONSULT.

\*6: When the fail safe operations for both self-diagnoses occur, the MIL illuminates.

\*7: SRT code will not be set if the self-diagnostic result is NG.

\*8: When the ECM is in the mode that displays SRT status, MIL may blink. For the details, refer to "How to Display SRT Status".

\*9: When erasing this DTC, always use CONSULT or GST.

## Test Value and Test Limit

INFOID:000000007768682

The following is the information specified in Service \$06 of SAE J1979/ISO 15031-5.

The test value is a parameter used to determine whether a system/circuit diagnostic test is OK or NG while being monitored by the ECM during self-diagnosis. The test limit is a reference value which is specified as the maximum or minimum value and is compared with the test value being monitored.

These data (test value and test limit) are specified by On Board Monitor ID (OBDMID), Test ID (TID), Unit and Scaling ID and can be displayed on the GST screen.

The items of the test value and test limit will be displayed with GST screen which items are provided by the ECM. (e.g., if bank 2 is not applied on this vehicle, only the items of bank 1 are displayed)

# ECM

< ECU DIAGNOSIS INFORMATION >

[VK56VD FOR USA AND CANADA]

| Item | OBD-MID | Self-diagnostic test item              | DTC   | Test value and Test limit (GST display) |                     | Description   |
|------|---------|--|-------|---|---------------------|---|
|      |         |  |       | TID                                     | Unit and Scaling ID |   |
| HO2S | 01H     | Air fuel ratio (A/F) sensor 1 (Bank 1) | P0131 | 83H                                     | 0BH                 | Minimum sensor output voltage for test cycle              |
|      |         |  | P0131 | 84H                                     | 0BH                 | Maximum sensor output voltage for test cycle              |
|      |         |  | P0130 | 85H                                     | 0BH                 | Minimum sensor output voltage for test cycle              |
|      |         |  | P0130 | 86H                                     | 0BH                 | Maximum sensor output voltage for test cycle              |
|      |         |  | P0133 | 87H                                     | 04H                 | Response rate: Response ratio (lean to rich)              |
|      |         |  | P0133 | 88H                                     | 04H                 | Response rate: Response ratio (rich to lean)              |
|      |         |  | P2A00 | 89H                                     | 84H                 | The amount of shift in air fuel ratio                     |
|      |         |  | P2A00 | 8AH                                     | 84H                 | The amount of shift in air fuel ratio                     |
|      |         |  | P0130 | 8BH                                     | 0BH                 | Difference in sensor output voltage                       |
|      |         |  | P0133 | 8CH                                     | 83H                 | Response gain at the limited frequency                    |
|      |         |  | P014C | 8DH                                     | 04H                 | O2 sensor slow response - Rich to lean bank 1 sensor 1    |
|      |         |  | P014C | 8EH                                     | 04H                 | O2 sensor slow response - Rich to lean bank 1 sensor 1    |
|      |         |  | P014D | 8FH                                     | 84H                 | O2 sensor slow response - Lean to rich bank 1 sensor 1    |
|      |         |  | P014D | 90H                                     | 84H                 | O2 sensor slow response - Lean to rich bank 1 sensor 1    |
|      |         |  | P015A | 91H                                     | 01H                 | O2 sensor delayed response - Rich to lean bank 1 sensor 1 |
|      |         |  | P015A | 92H                                     | 01H                 | O2 sensor delayed response - Rich to lean bank 1 sensor 1 |
|      |         |  | P015B | 93H                                     | 01H                 | O2 sensor delayed response - Lean to rich bank 1 sensor 1 |
|      |         |  | P015B | 94H                                     | 01H                 | O2 sensor delayed response - Lean to rich bank 1 sensor 1 |
|      | 02H     | Heated oxygen sensor 2 (Bank 1)        | P0138 | 07H                                     | 0CH                 | Minimum sensor output voltage for test cycle              |
|      |         |  | P0137 | 08H                                     | 0CH                 | Maximum sensor output voltage for test cycle              |
|      |         |  | P0138 | 80H                                     | 0CH                 | Sensor output voltage                                     |
|      |         |  | P0139 | 81H                                     | 0CH                 | Difference in sensor output voltage                       |
|      |         |  | P0139 | 82H                                     | 11H                 | Rear O2 sensor delay response diagnosis                   |
|      | 03H     | Heated oxygen sensor 3 (Bank 1)        | P0143 | 07H                                     | 0CH                 | Minimum sensor output voltage for test cycle              |
|      |         |  | P0144 | 08H                                     | 0CH                 | Maximum sensor output voltage for test cycle              |
|      |         |  | P0146 | 80H                                     | 0CH                 | Sensor output voltage                                     |
|      |         |  | P0145 | 81H                                     | 0CH                 | Difference in sensor output voltage                       |

# ECM

< ECU DIAGNOSIS INFORMATION >

[VK56VD FOR USA AND CANADA]

| Item | OBD-MID | Self-diagnostic test item              | DTC   | Test value and Test limit (GST display) |                     | Description   |
|------|---------|--|-------|---|---------------------|---|
|      |         |  |       | TID                                     | Unit and Scaling ID |   |
| HO2S | 05H     | Air fuel ratio (A/F) sensor 1 (Bank 2) | P0151 | 83H                                     | 0BH                 | Minimum sensor output voltage for test cycle              |
|      |         |  | P0151 | 84H                                     | 0BH                 | Maximum sensor output voltage for test cycle              |
|      |         |  | P0150 | 85H                                     | 0BH                 | Minimum sensor output voltage for test cycle              |
|      |         |  | P0150 | 86H                                     | 0BH                 | Maximum sensor output voltage for test cycle              |
|      |         |  | P0153 | 87H                                     | 04H                 | Response rate: Response ratio (lean to rich)              |
|      |         |  | P0153 | 88H                                     | 04H                 | Response rate: Response ratio (rich to lean)              |
|      |         |  | P2A03 | 89H                                     | 84H                 | The amount of shift in air fuel ratio                     |
|      |         |  | P2A03 | 8AH                                     | 84H                 | The amount of shift in air fuel ratio                     |
|      |         |  | P0150 | 8BH                                     | 0BH                 | Difference in sensor output voltage                       |
|      |         |  | P0153 | 8CH                                     | 83H                 | Response gain at the limited frequency                    |
|      |         |  | P014E | 8DH                                     | 04H                 | O2 sensor slow response - Rich to lean bank 2 sensor 1    |
|      |         |  | P014E | 8EH                                     | 04H                 | O2 sensor slow response - Rich to lean bank 2 sensor 1    |
|      |         |  | P014F | 8FH                                     | 84H                 | O2 sensor slow response - Lean to rich bank 2 sensor 1    |
|      |         |  | P014F | 90H                                     | 84H                 | O2 sensor slow response - Lean to rich bank 2 sensor 1    |
|      |         |  | P015C | 91H                                     | 01H                 | O2 sensor delayed response - Rich to lean bank 2 sensor 1 |
|      |         |  | P015C | 92H                                     | 01H                 | O2 sensor delayed response - Rich to lean bank 2 sensor 1 |
|      |         |  | P015D | 93H                                     | 01H                 | O2 sensor delayed response - Lean to rich bank 2 sensor 1 |
|      |         |  | P015D | 94H                                     | 01H                 | O2 sensor delayed response - Lean to rich bank 2 sensor 1 |
|      | 06H     | Heated oxygen sensor 2 (Bank 2)        | P0158 | 07H                                     | 0CH                 | Minimum sensor output voltage for test cycle              |
|      |         |  | P0157 | 08H                                     | 0CH                 | Maximum sensor output voltage for test cycle              |
|      |         |  | P0158 | 80H                                     | 0CH                 | Sensor output voltage                                     |
|      |         |  | P0159 | 81H                                     | 0CH                 | Difference in sensor output voltage                       |
|      |         |  | P0159 | 82H                                     | 11H                 | Rear O2 sensor delay response diagnosis                   |
|      | 07H     | Heated oxygen sensor 3 (Bank2)         | P0163 | 07H                                     | 0CH                 | Minimum sensor output voltage for test cycle              |
|      |         |  | P0164 | 08H                                     | 0CH                 | Maximum sensor output voltage for test cycle              |
|      |         |  | P0166 | 80H                                     | 0CH                 | Sensor output voltage                                     |
|      |         |  | P0165 | 81H                                     | 0CH                 | Difference in sensor output voltage                       |

A

EC

C

D

E

F

G

H

I

J

K

L

M

N

O

P

# ECM

< ECU DIAGNOSIS INFORMATION >

[VK56VD FOR USA AND CANADA]

| Item       | OBD-MID | Self-diagnostic test item           | DTC   | Test value and Test limit (GST display) |                     | Description  |
|------------|---------|-------------------------------------|-------|---|---------------------|--|
|            |         |                                     |       | TID                                     | Unit and Scaling ID |  |
| CATALYST   | 21H     | Three way catalyst function (Bank1) | P0420 | 80H                                     | 01H                 | O2 storage index   |
|            |         |                                     | P0420 | 82H                                     | 01H                 | Switching time lag engine exhaust index value  |
|            |         |                                     | P2423 | 83H                                     | 0CH                 | Difference in 3rd O2 sensor output voltage   |
|            |         |                                     | P2423 | 84H                                     | 84H                 | O2 storage index in HC trap catalyst   |
|            | 22H     | Three way catalyst function (Bank2) | P0430 | 80H                                     | 01H                 | O2 storage index   |
|            |         |                                     | P0430 | 82H                                     | 01H                 | Switching time lag engine exhaust index value  |
|            |         |                                     | P2424 | 83H                                     | 0CH                 | Difference in 3rd O2 sensor output voltage   |
|            |         |                                     | P2424 | 84H                                     | 84H                 | O2 storage index in HC trap catalyst   |
| EGR SYSTEM | 31H     | EGR function                        | P0400 | 80H                                     | 96H                 | Low flow faults: EGR temp change rate (short term)                                   |
|            |         |                                     | P0400 | 81H                                     | 96H                 | Low flow faults: EGR temp change rate (long term)                                    |
|            |         |                                     | P0400 | 82H                                     | 96H                 | Low flow faults: Difference between max EGR temp and EGR temp under idling condition |
|            |         |                                     | P0400 | 83H                                     | 96H                 | Low flow faults: Max EGR temp  |
|            |         |                                     | P1402 | 84H                                     | 96H                 | High Flow Faults: EGR temp increase rate   |
| VVT SYSTEM | 35H     | VVT Monitor (Bank1)                 | P0011 | 80H                                     | 9DH                 | VTC intake function diagnosis (VTC alignment check diagnosis)                        |
|            |         |                                     | P0014 | 81H                                     | 9DH                 | VTC exhaust function diagnosis (VTC alignment check diagnosis)                       |
|            |         |                                     | P0011 | 82H                                     | 9DH                 | VTC intake function diagnosis (VTC drive failure diagnosis)                          |
|            |         |                                     | P0014 | 83H                                     | 9DH                 | VTC exhaust function diagnosis (VTC drive failure diagnosis)                         |
|            |         |                                     | P100A | 84H                                     | 10H                 | VEL slow response diagnosis  |
|            |         |                                     | P1090 | 85H                                     | 10H                 | VEL servo system diagnosis   |
|            | 36H     | VVT Monitor (Bank2)                 | P0021 | 80H                                     | 9DH                 | VTC intake function diagnosis (VTC alignment check diagnosis)                        |
|            |         |                                     | P0024 | 81H                                     | 9DH                 | VTC exhaust function diagnosis (VTC alignment check diagnosis)                       |
|            |         |                                     | P0021 | 82H                                     | 9DH                 | VTC intake function diagnosis (VTC drive failure diagnosis)                          |
|            |         |                                     | P0024 | 83H                                     | 9DH                 | VTC exhaust function diagnosis (VTC drive failure diagnosis)                         |
|            |         |                                     | P100B | 84H                                     | 10H                 | VEL slow response diagnosis  |
|            |         |                                     | P1093 | 85H                                     | 10H                 | VEL servo system diagnosis   |

# ECM

< ECU DIAGNOSIS INFORMATION >

[VK56VD FOR USA AND CANADA]

| Item             | OBD-MID           | Self-diagnostic test item                  | DTC                                   | Test value and Test limit (GST display) |  | Description   |
|------------------|-------------------|--|---------------------------------------|---|--|---|
|                  |                   |  |                                       | TID                                     | Unit and Scaling ID  |   |
| EVAP SYSTEM      | 39H               | EVAP control system leak (Cap Off)         | P0455                                 | 80H                                     | 0CH  | Difference in pressure sensor output voltage before and after pull down |
|                  | 3BH               | EVAP control system leak (Small leak)      | P0442                                 | 80H                                     | 05H  | Leak area index (for more than 0.04 inch)                               |
|                  | 3CH               | EVAP control system leak (Very small leak) | P0456                                 | 80H                                     | 05H  | Leak area index (for more than 0.02 inch)                               |
|                  |                   |  | P0456                                 | 81H                                     | FDH  | Maximum internal pressure of EVAP system during monitoring              |
|                  |                   |  | P0456                                 | 82H                                     | FDH  | Internal pressure of EVAP system at the end of monitoring               |
| 3DH              | Purge flow system | P0441                                      | 83H                                   | 0CH                                     | Difference in pressure sensor output voltage before and after vent control valve close |   |
| O2 SENSOR HEATER | 41H               | A/F sensor 1 heater (Bank 1)               | Low Input: P0031<br>High Input: P0032 | 81H                                     | 0BH  | Converted value of heater electric current to voltage                   |
|                  | 42H               | Heated oxygen sensor 2 heater (Bank 1)     | Low Input: P0037<br>High Input: P0038 | 80H                                     | 0CH  | Converted value of heater electric current to voltage                   |
|                  | 43H               | Heated oxygen sensor 3 heater (Bank 1)     | P0043                                 | 80H                                     | 0CH  | Converted value of heater electric current to voltage                   |
|                  | 45H               | A/F sensor 1 heater (Bank 2)               | Low Input: P0051<br>High Input: P0052 | 81H                                     | 0BH  | Converted value of heater electric current to voltage                   |
|                  | 46H               | Heated oxygen sensor 2 heater (Bank 2)     | Low Input: P0057<br>High Input: P0058 | 80H                                     | 0CH  | Converted value of heater electric current to voltage                   |
|                  | 47H               | Heated oxygen sensor 3 heater (Bank 2)     | P0063                                 | 80H                                     | 0CH  | Converted value of heater electric current to voltage                   |
| SECONDARY AIR    | 71H               | Secondary air system                       | P0411                                 | 80H                                     | 01H  | Secondary air injection system incorrect flow detected                  |
|                  |                   |  | Bank1: P0491<br>Bank2: P0492          | 81H                                     | 01H  | Secondary air injection system insufficient flow                        |
|                  |                   |  | P2445                                 | 82H                                     | 01H  | Secondary air injection system pump stuck off                           |
|                  |                   |  | P2448                                 | 83H                                     | 01H  | Secondary air injection system high airflow                             |
|                  |                   |  | Bank1: P2440<br>Bank2: P2442          | 84H                                     | 01H  | Secondary air injection system switching valve stuck open               |
|                  |                   |  | P2440                                 | 85H                                     | 01H  | Secondary air injection system switching valve stuck open               |
|                  |                   |  | P2444                                 | 86H                                     | 01H  | Secondary air injection system pump stuck on                            |
| FUEL SYSTEM      | 81H               | Fuel injection system function (Bank 1)    | P0171 or P0172                        | 80H                                     | 2FH  | Long term fuel trim   |
|                  |                   |  | P0171 or P0172                        | 81H                                     | 24H  | The number of lambda control clamped                                    |
|                  |                   |  | P117A                                 | 82H                                     | 03H  | Cylinder A/F imbalance monitoring                                       |
|                  | 82H               | Fuel injection system function (Bank 2)    | P0174 or P0175                        | 80H                                     | 2FH  | Long term fuel trim   |
|                  |                   |  | P0174 or P0175                        | 81H                                     | 24H  | The number of lambda control clamped                                    |
|                  |                   |  | P117B                                 | 82H                                     | 03H  | Cylinder A/F imbalance monitoring                                       |

A

EC

C

D

E

F

G

H

I

J

K

L

M

N

O

P

# ECM

< ECU DIAGNOSIS INFORMATION >

[VK56VD FOR USA AND CANADA]

| Item    | OBD-MID | Self-diagnostic test item  | DTC   | Test value and Test limit (GST display) |                     | Description  |
|---------|---------|----------------------------|-------|---|---------------------|--|
|         |         |                            |       | TID                                     | Unit and Scaling ID |  |
| MISFIRE | A1H     | Multiple cylinder misfires | P0301 | 80H                                     | 24H                 | Misfiring counter at 1000 revolution of the first cylinder     |
|         |         |                            | P0302 | 81H                                     | 24H                 | Misfiring counter at 1000 revolution of the second cylinder    |
|         |         |                            | P0303 | 82H                                     | 24H                 | Misfiring counter at 1000 revolution of the third cylinder     |
|         |         |                            | P0304 | 83H                                     | 24H                 | Misfiring counter at 1000 revolution of the fourth cylinder    |
|         |         |                            | P0305 | 84H                                     | 24H                 | Misfiring counter at 1000 revolution of the fifth cylinder     |
|         |         |                            | P0306 | 85H                                     | 24H                 | Misfiring counter at 1000 revolution of the sixth cylinder     |
|         |         |                            | P0307 | 86H                                     | 24H                 | Misfiring counter at 1000 revolution of the seventh cylinder   |
|         |         |                            | P0308 | 87H                                     | 24H                 | Misfiring counter at 1000 revolution of the eighth cylinder    |
|         |         |                            | P0300 | 88H                                     | 24H                 | Misfiring counter at 1000 revolution of the multiple cylinders |
|         |         |                            | P0301 | 89H                                     | 24H                 | Misfiring counter at 200 revolution of the first cylinder      |
|         |         |                            | P0302 | 8AH                                     | 24H                 | Misfiring counter at 200 revolution of the second cylinder     |
|         |         |                            | P0303 | 8BH                                     | 24H                 | Misfiring counter at 200 revolution of the third cylinder      |
|         |         |                            | P0304 | 8CH                                     | 24H                 | Misfiring counter at 200 revolution of the fourth cylinder     |
|         |         |                            | P0305 | 8DH                                     | 24H                 | Misfiring counter at 200 revolution of the fifth cylinder      |
|         |         |                            | P0306 | 8EH                                     | 24H                 | Misfiring counter at 200 revolution of the sixth cylinder      |
|         |         |                            | P0307 | 8FH                                     | 24H                 | Misfiring counter at 200 revolution of the seventh cylinder    |
|         |         |                            | P0308 | 90H                                     | 24H                 | Misfiring counter at 200 revolution of the eighth cylinder     |
|         |         |                            | P0300 | 91H                                     | 24H                 | Misfiring counter at 1000 revolution of the single cylinder    |
|         |         |                            | P0300 | 92H                                     | 24H                 | Misfiring counter at 200 revolution of the single cylinder     |
|         |         |                            | P0300 | 93H                                     | 24H                 | Misfiring counter at 200 revolution of the multiple cylinders  |

# ECM

< ECU DIAGNOSIS INFORMATION >

[VK56VD FOR USA AND CANADA]

| Item    | OBD-MID | Self-diagnostic test item | DTC   | Test value and Test limit (GST display) |                     | Description  |
|---------|---------|---------------------------|-------|---|---------------------|--|
|         |         |                           |       | TID                                     | Unit and Scaling ID |  |
| MISFIRE | A2H     | No. 1 cylinder misfire    | P0301 | 0BH                                     | 24H                 | EWMA (Exponential Weighted Moving Average) misfire counts for last 10 driving cycles |
|         |         |                           | P0301 | 0CH                                     | 24H                 | Misfire counts for last/current driving cycles                                       |
|         | A3H     | No. 2 cylinder misfire    | P0302 | 0BH                                     | 24H                 | EWMA (Exponential Weighted Moving Average) misfire counts for last 10 driving cycles |
|         |         |                           | P0302 | 0CH                                     | 24H                 | Misfire counts for last/current driving cycles                                       |
|         | A4H     | No. 3 cylinder misfire    | P0303 | 0BH                                     | 24H                 | EWMA (Exponential Weighted Moving Average) misfire counts for last 10 driving cycles |
|         |         |                           | P0303 | 0CH                                     | 24H                 | Misfire counts for last/current driving cycles                                       |
|         | A5H     | No. 4 cylinder misfire    | P0304 | 0BH                                     | 24H                 | EWMA (Exponential Weighted Moving Average) misfire counts for last 10 driving cycles |
|         |         |                           | P0304 | 0CH                                     | 24H                 | Misfire counts for last/current driving cycles                                       |
|         | A6H     | No. 5 cylinder misfire    | P0305 | 0BH                                     | 24H                 | EWMA (Exponential Weighted Moving Average) misfire counts for last 10 driving cycles |
|         |         |                           | P0305 | 0CH                                     | 24H                 | Misfire counts for last/current driving cycles                                       |
|         | A7H     | No. 6 cylinder misfire    | P0306 | 0BH                                     | 24H                 | EWMA (Exponential Weighted Moving Average) misfire counts for last 10 driving cycles |
|         |         |                           | P0306 | 0CH                                     | 24H                 | Misfire counts for last/current driving cycles                                       |
|         | A8H     | No. 7 cylinder misfire    | P0307 | 0BH                                     | 24H                 | EWMA (Exponential Weighted Moving Average) misfire counts for last 10 driving cycles |
|         |         |                           | P0307 | 0CH                                     | 24H                 | Misfire counts for last/current driving cycles                                       |
|         | A9H     | No. 8 cylinder misfire    | P0308 | 0BH                                     | 24H                 | EWMA (Exponential Weighted Moving Average) misfire counts for last 10 driving cycles |
|         |         |                           | P0308 | 0CH                                     | 24H                 | Misfire counts for last/current driving cycles                                       |

A  
EC  
C  
D  
E  
F  
G  
H  
I  
J  
K  
L  
M  
N  
O  
P

# VVEL CONTROL MODULE

< ECU DIAGNOSIS INFORMATION >

[VK56VD FOR USA AND CANADA]

## VVEL CONTROL MODULE

### Reference Value

INFOID:000000007187421

### TERMINAL LAYOUT

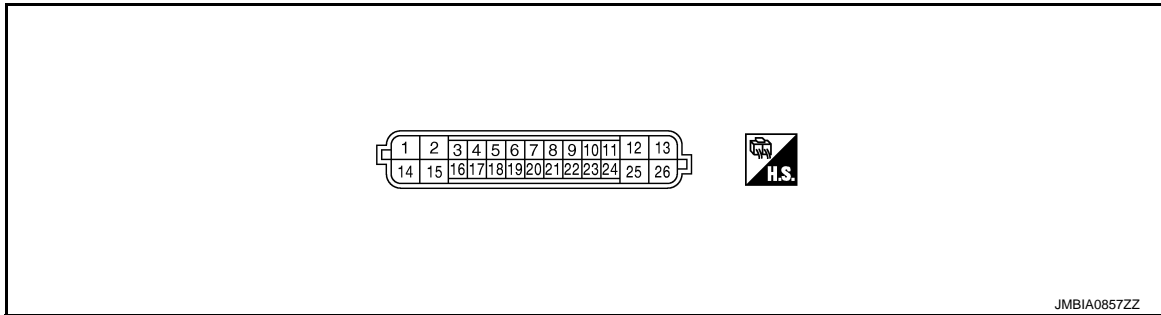

### PHYSICAL VALUES

#### NOTE:

- VVEL control module is located under the battery. Temporarily remove the battery to check voltage of the terminals.
- Specification data are reference values and are measured between each terminals.
- Pulse signal is measured by CONSULT.

| Terminal No. |             | Description   |              | Condition   | Value (Approx.)               |
|--------------|-------------|---|--------------|---|-------------------------------|
| +            | -           | Signal name   | Input/Output |   |                               |
| 1<br>(W)     | 14<br>(B/R) | VVEL actuator motor power supply (bank 2)                     | Input        | [Ignition switch: ON]   | BATTERY VOLTAGE<br>(11 - 14V) |
| 2<br>(L/B)   | 14<br>(B/R) | VVEL actuator motor (High lift) (bank 2)                      | Output       | [Engine is running]<br>• Warm-up condition<br>• Idle speed                                  | 0 - 14 V★<br><br>JMBIA0854ZZ  |
|              |             |   |              | [Engine is running]<br>• Warm-up condition<br>• When revving engine up to 2,000 rpm quickly | 0 - 14 V★<br><br>JMBIA0855ZZ  |
| 3<br>(Y)     | 6<br>(B)    | VVEL control shaft position sensor 1 (bank 1)                 | Input        | [Engine is running]<br>• Warm-up condition<br>• Idle speed                                  | 0.25 - 1.40 V                 |
|              |             |   |              | [Engine is running]<br>• Warm-up condition<br>• When revving engine up to 3,000 rpm quickly | 0.25 - 4.75 V                 |
| 4<br>(W)     | —           | Sensor ground [VVEL control shaft position sensor 1 (bank 2)] | —            | —   | —                             |



# VVEL CONTROL MODULE

< ECU DIAGNOSIS INFORMATION >

[VK56VD FOR USA AND CANADA]

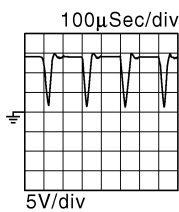
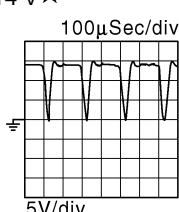
| Terminal No. |             | Description   |              | Condition   | Value (Approx.)  |
|--------------|-------------|---|--------------|---|--|
| +            | -           | Signal name   | Input/Output |   |  |
| 5<br>(L)     | 4<br>(W)    | VVEL control shaft position sensor 1 (bank 2)                       | Input        | [Engine is running]<br>• Warm-up condition<br>• Idle speed                                  | 0.25 - 1.40 V  |
|              |             |   |              | [Engine is running]<br>• Warm-up condition<br>• When revving engine up to 3,000 rpm quickly | 0.25 - 4.75 V  |
| 6<br>(B)     | —           | Sensor ground [VVEL control shaft position sensor 1 (bank 1)]       | —            | —   | —  |
| 7<br>(W)     | 6<br>(B)    | Sensor power supply [VVEL control shaft position sensor 1 (bank 1)] | —            | [Ignition switch: ON]   | 5 V  |
| 8<br>(R)     | 14<br>(B/R) | Power supply for VVEL control module                                | —            | [Ignition switch: ON]   | BATTERY VOLTAGE (11 - 14 V)  |
| 9<br>(B)     | 4<br>(W)    | Sensor power supply [VVEL position sensor 1 (bank 2)]               | —            | [Ignition switch: ON]   | 5 V  |
| 11<br>(GR)   | —           | ENG communication line  | Input/Output | —   | —  |
| 12<br>(L/B)  | 14<br>(B/R) | VVEL actuator motor (High lift) (bank 1)                            | Output       | [Engine is running]<br>• Warm-up condition<br>• Idle speed                                  | 0 - 14 V★<br>  |
|              |             |   |              | [Engine is running]<br>• Warm-up condition<br>• When revving engine up to 3,000 rpm quickly | 0 - 14 V★<br> |
| 13<br>(W)    | 14<br>(B/R) | VVEL actuator motor power supply (bank 1)                           | Input        | [Ignition switch: ON]   | BATTERY VOLTAGE (11 - 14 V)  |
| 14<br>(B/R)  | —           | VVEL control module ground  | —            | —   | —  |

A  
EC  
C  
D  
E  
F  
G  
H  
I  
J  
K  
L  
M  
N  
O  
P

# VVEL CONTROL MODULE

< ECU DIAGNOSIS INFORMATION >

[VK56VD FOR USA AND CANADA]

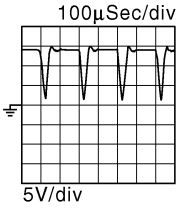
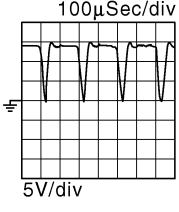
| Terminal No. |             | Description  |              | Condition   | Value (Approx.)  |
|--------------|-------------|--|--------------|---|--|
| +            | -           | Signal name  | Input/Output |   |  |
| 15<br>(L/W)  | 14<br>(B/R) | VVEL actuator motor<br>(Low lift) (bank 2)                             | Output       | [Engine is running]<br>• Warm-up condition<br>• Idle speed                                  | 0 - 14 V★<br> |
|              |             |  |              | [Engine is running]<br>• Warm-up condition<br>• When revving engine up to 3,000 rpm quickly | 0 - 14 V★<br> |
| 16<br>(G)    | 19<br>(L)   | VVEL control shaft position sensor 2 (bank 1)                          | Input        | [Engine is running]<br>• Warm-up condition<br>• Idle speed                                  | 3.50 - 4.75 V  |
|              |             |  |              | [Engine is running]<br>• Warm-up condition<br>• When revving engine up to 3,000 rpm quickly | 0.25 - 4.75 V  |
| 17<br>(Y)    | —           | Sensor ground<br>[VVEL control shaft position sensor 2 (bank 2)]       | —            | —   | —  |
| 18<br>(R)    | 17<br>(L)   | VVEL control shaft position sensor 2 (bank 2)                          | Input        | [Engine is running]<br>• Warm-up condition<br>• Idle speed                                  | 3.50 - 4.75 V  |
|              |             |  |              | [Engine is running]<br>• Warm-up condition<br>• When revving engine up to 3,000 rpm quickly | 0.25 - 4.75 V  |
| 19<br>(L)    | —           | Sensor ground<br>[VVEL control shaft position sensor 2 (bank 1)]       | —            | —   | —  |
| 20<br>(R)    | 19<br>(L)   | Sensor power supply<br>[VVEL control shaft position sensor 2 (bank 1)] | —            | [Ignition switch: ON]   | 5 V  |
| 21<br>(V)    | 14<br>(B/R) | VVEL actuator motor relay abort signal<br>[ECM]                        | Input        | [Engine is running]<br>• Warm-up condition<br>• Idle speed                                  | 0 V  |
| 22<br>(G)    | 17<br>(Y)   | Sensor power supply<br>[VVEL control shaft position sensor 2 (bank 2)] | —            | [Ignition switch: ON]   | 5 V  |
| 23<br>(P)    | 14<br>(B/R) | VVEL control motor relay   | Output       | [Ignition switch: OFF]  | BATTERY VOLTAGE<br>(11 - 14 V)   |
|              |             |  |              | [Ignition switch: ON]   | 0 - 1.0 V  |
| 24<br>(L)    | —           | ENG communication line   | Input/Output | —   | —  |

# VVEL CONTROL MODULE

< ECU DIAGNOSIS INFORMATION >

[VK56VD FOR USA AND CANADA]

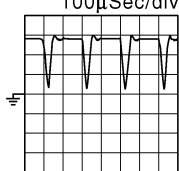
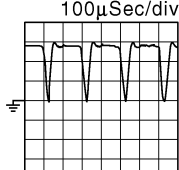
| Terminal No. |             | Description                               |              | Condition  | Value (Approx.)   |
|--------------|-------------|---|--------------|--|---|
| +            | -           | Signal name                               | Input/Output |  |   |
| 25<br>(L/W)  | 14<br>(B/R) | VVEL control motor<br>(Low lift) (bank 1) | Output       | [Engine is running] <ul style="list-style-type: none"> <li>• Warm-up condition</li> <li>• Idle speed</li> </ul>                                  | 0 - 14 V★<br>100μSec/div<br><br>5V/div JMBIA0854ZZ |
|              |             |   |              | [Engine is running] <ul style="list-style-type: none"> <li>• Warm-up condition</li> <li>• When revving engine up to 3,000 rpm quickly</li> </ul> | 0 - 14 V★<br>100μSec/div<br><br>5V/div JMBIA0855ZZ |

★: Average voltage for pulse signal (Actual pulse signal can be confirmed by oscilloscope.)

A  
EC  
C  
D  
E  
F  
G  
H  
I  
J  
K  
L  
M  
N  
O  
P

# ENGINE CONTROL SYSTEM

[VK56VD FOR USA AND CANADA]

< WIRING DIAGRAM >

## WIRING DIAGRAM

### ENGINE CONTROL SYSTEM

#### Wiring Diagram

INFOID:000000006883298

For connector terminal arrangements, harness layouts, and alphabets in a  (option abbreviation; if not described in wiring diagram), refer to [GI-12, "Connector Information"](#).

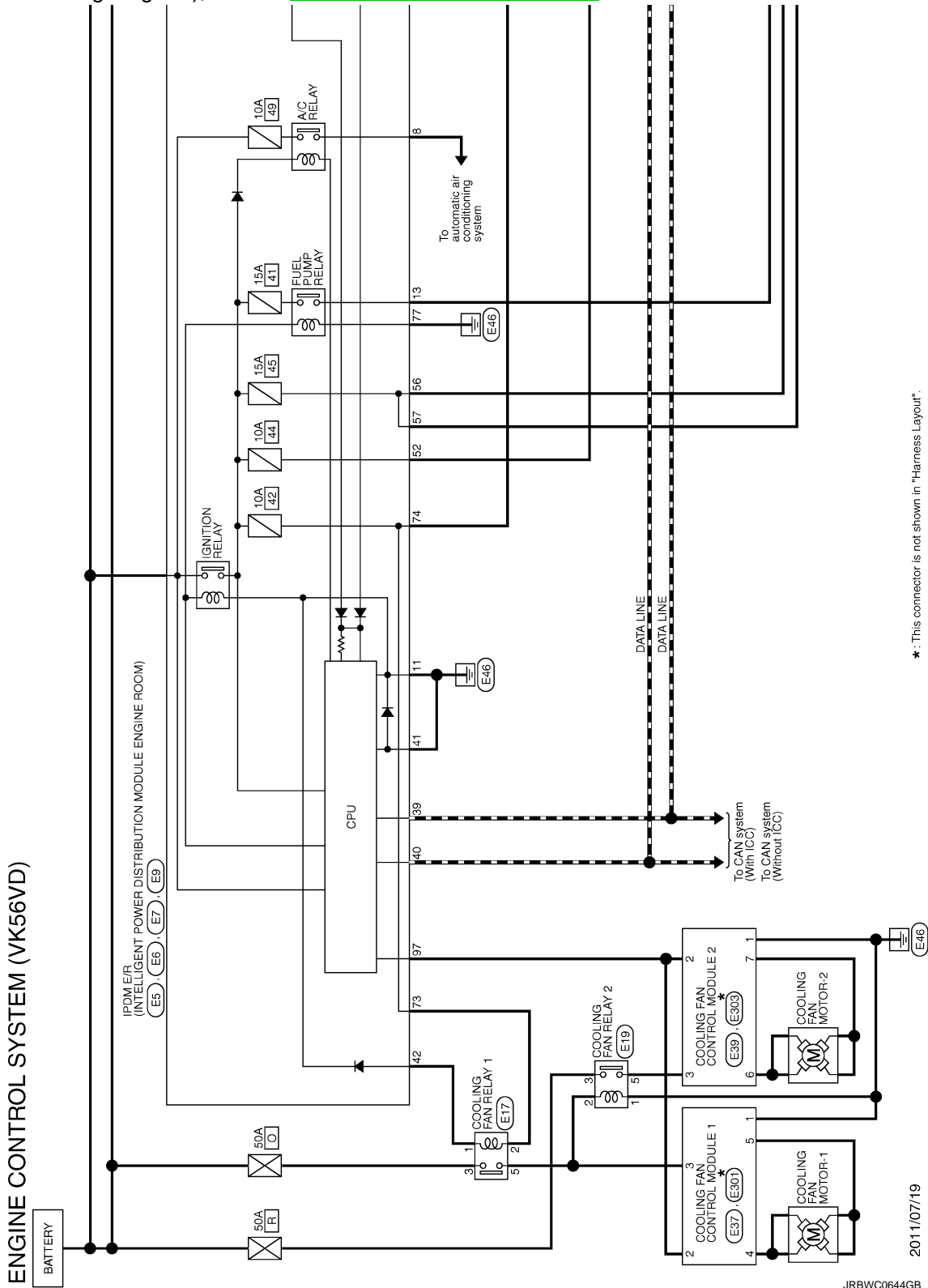

\*: This connector is not shown in "Harness Layout".

# ENGINE CONTROL SYSTEM

[VK56VD FOR USA AND CANADA]

< WIRING DIAGRAM >

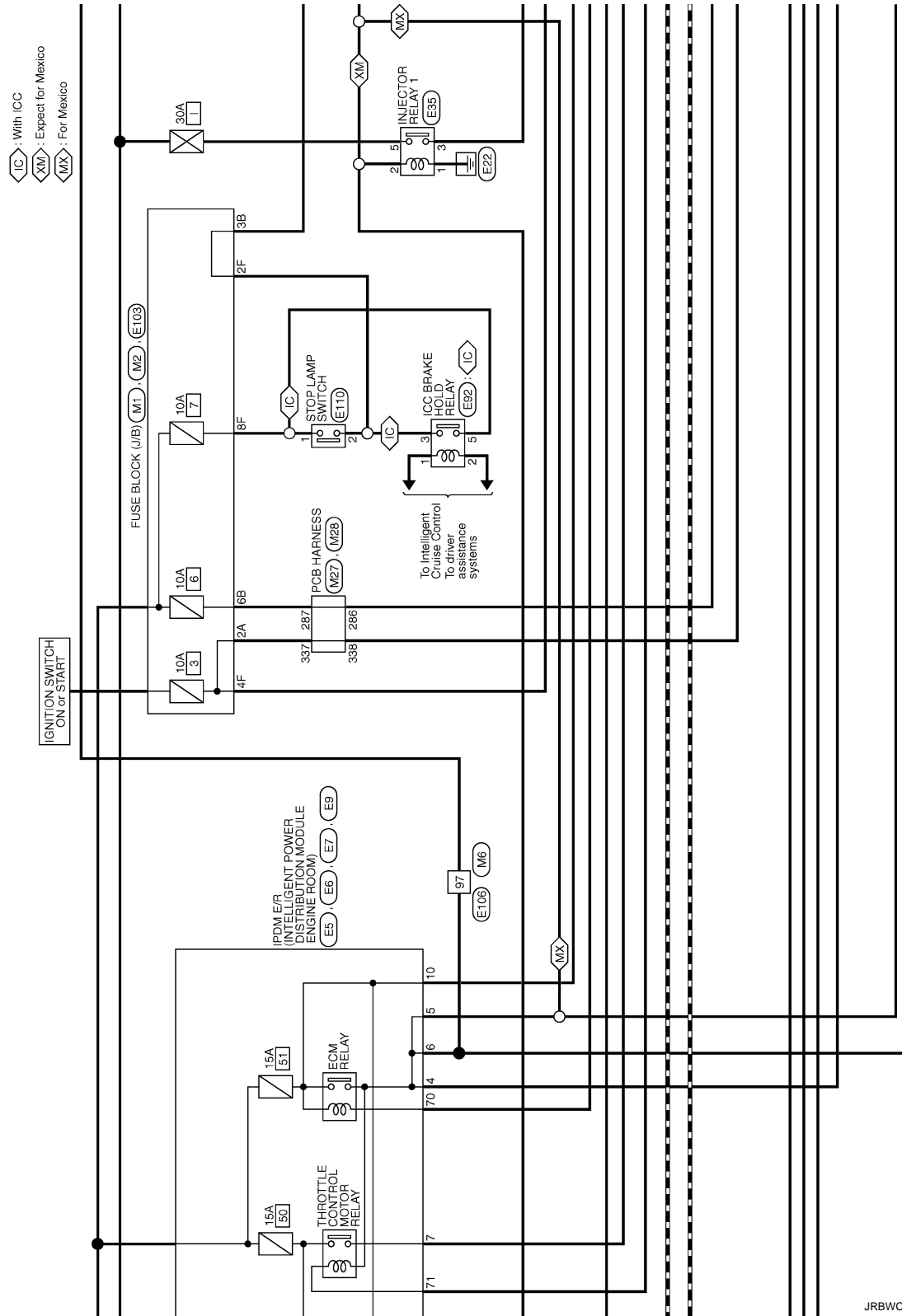

JRBWC0645GB

A  
EC  
C  
D  
E  
F  
G  
H  
I  
J  
K  
L  
M  
N  
O  
P

# ENGINE CONTROL SYSTEM

[VK56VD FOR USA AND CANADA]

< WIRING DIAGRAM >

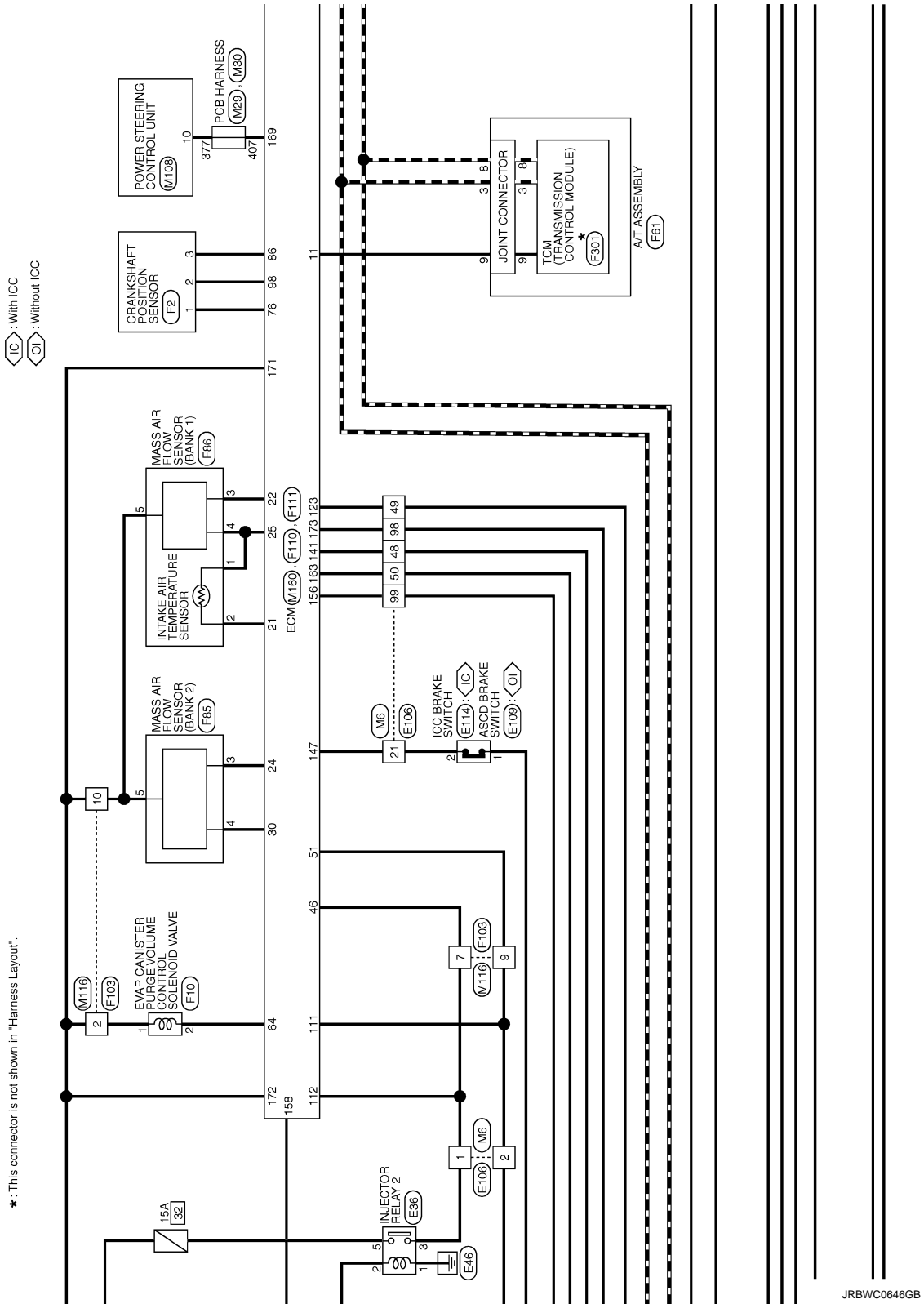

JRBWC0646GB

# ENGINE CONTROL SYSTEM

[VK56VD FOR USA AND CANADA]

< WIRING DIAGRAM >

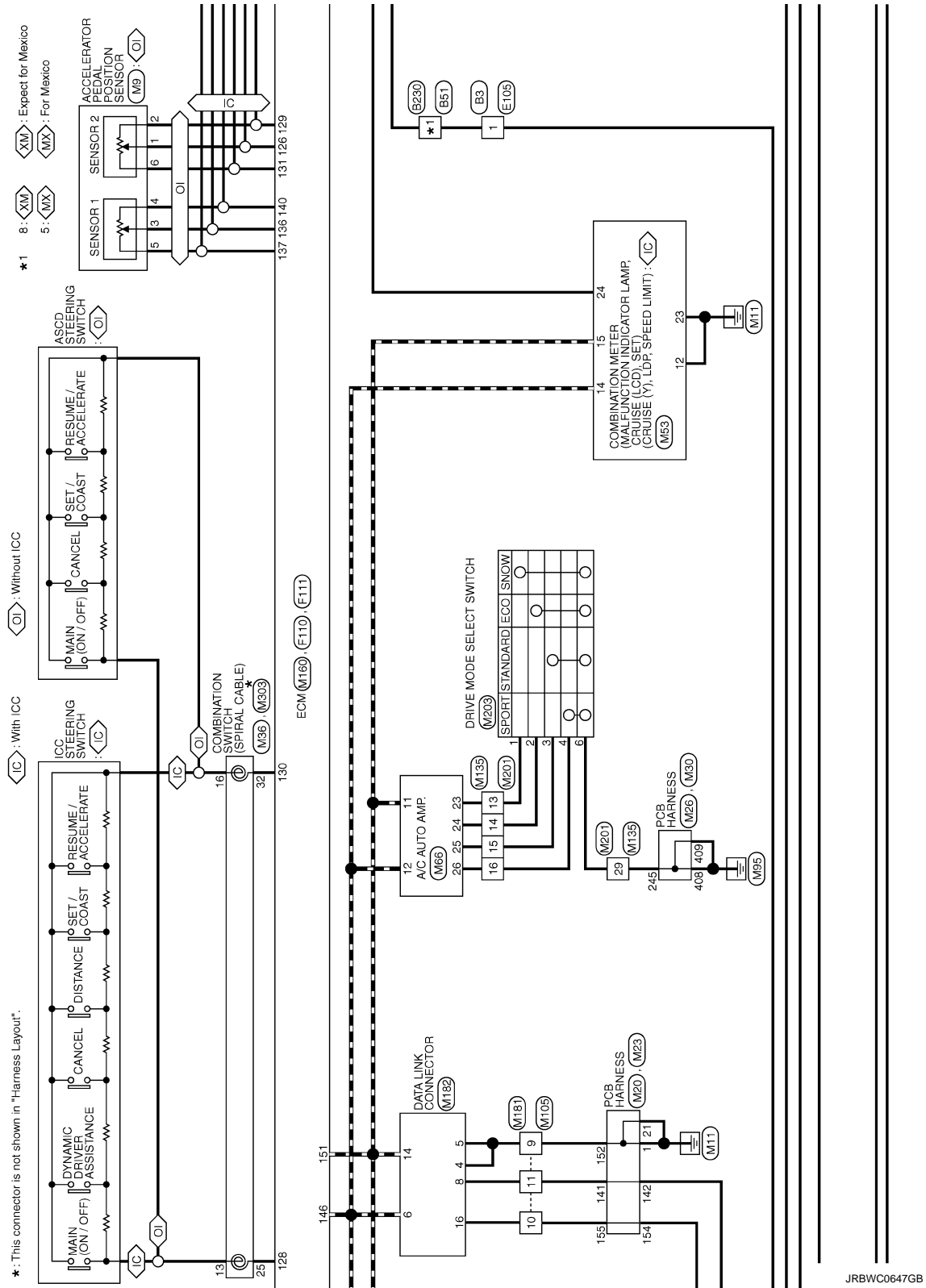

JRBWC0647GB

A  
EC  
C  
D  
E  
F  
G  
H  
I  
J  
K  
L  
M  
N  
O  
P

# ENGINE CONTROL SYSTEM

[VK56VD FOR USA AND CANADA]

< WIRING DIAGRAM >

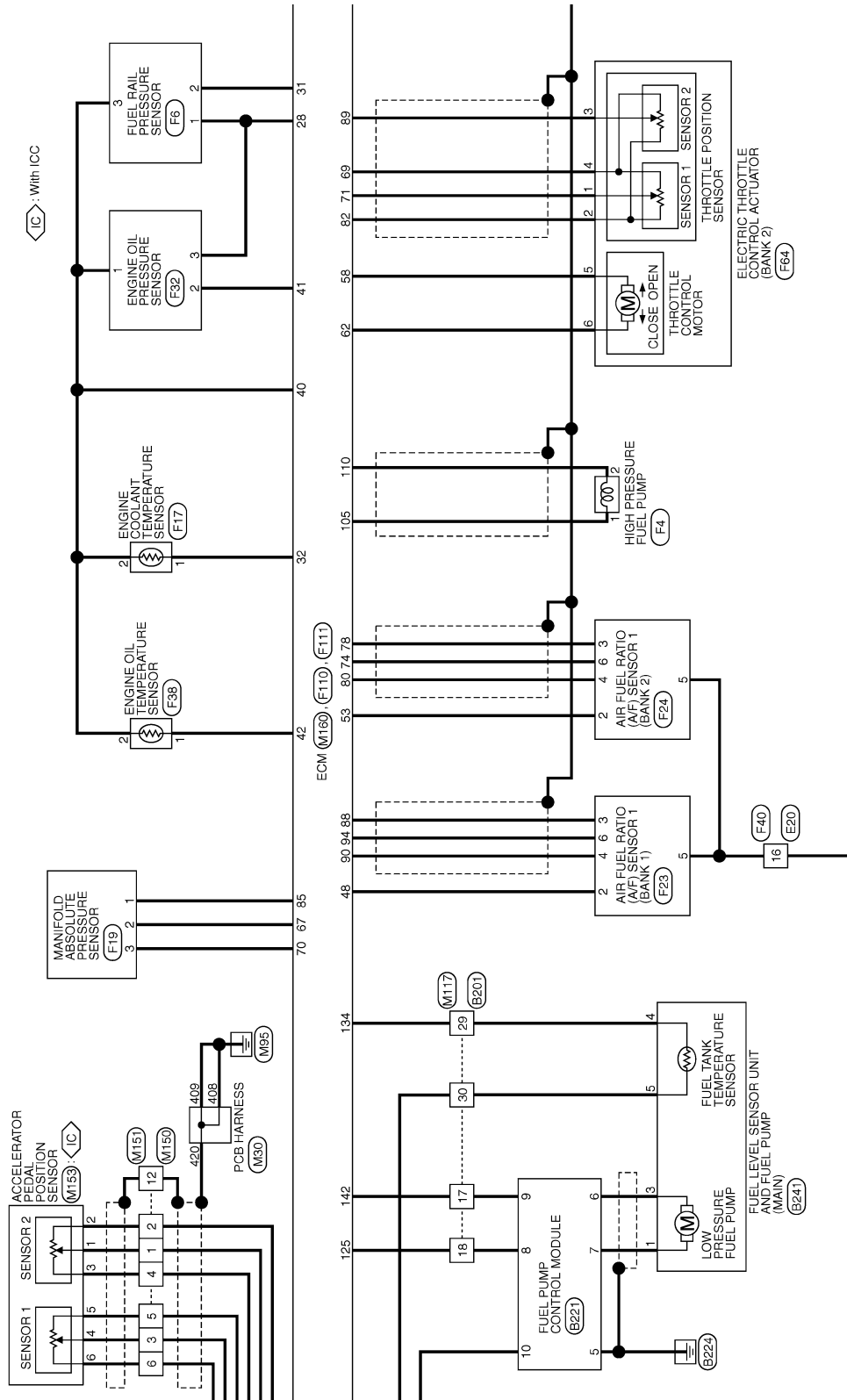

JRBWC0648GB



# ENGINE CONTROL SYSTEM

[VK56VD FOR USA AND CANADA]

< WIRING DIAGRAM >

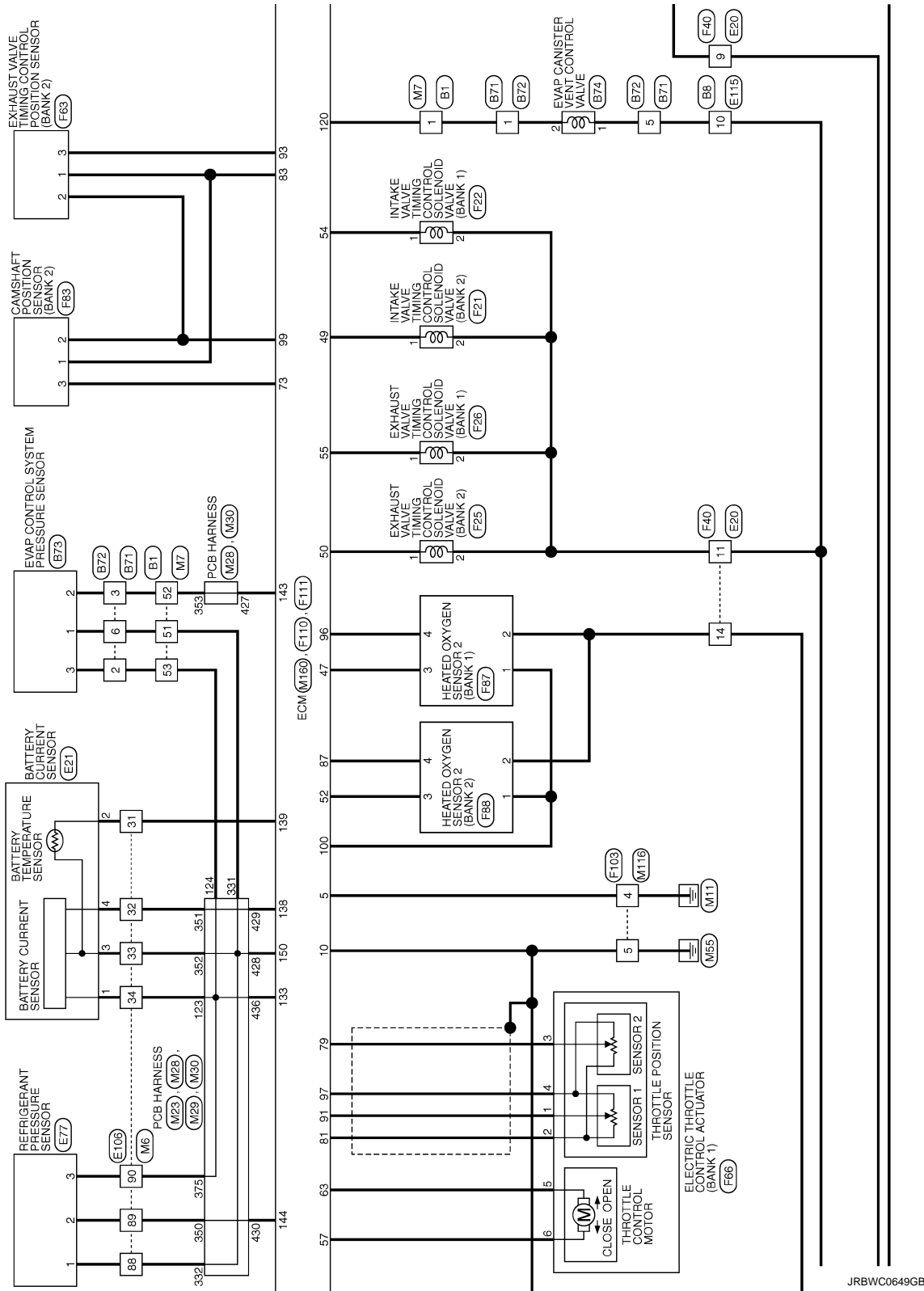

JRBWC0649GB

A  
EC  
C  
D  
E  
F  
G  
H  
I  
J  
K  
L  
M  
N  
O  
P

# ENGINE CONTROL SYSTEM

[VK56VD FOR USA AND CANADA]

< WIRING DIAGRAM >

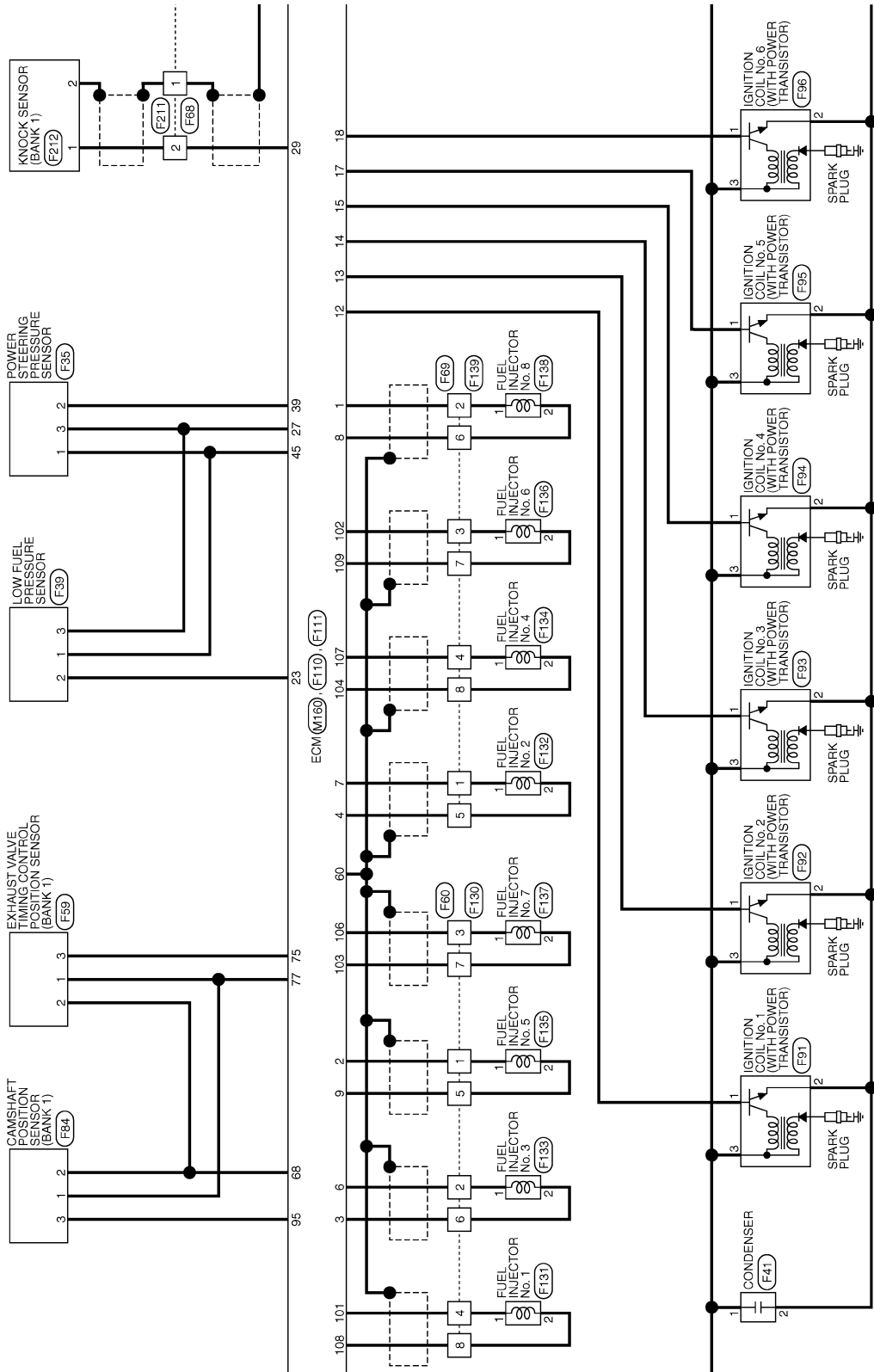

JRBWC0650GB

# ENGINE CONTROL SYSTEM

[VK56VD FOR USA AND CANADA]

< WIRING DIAGRAM >

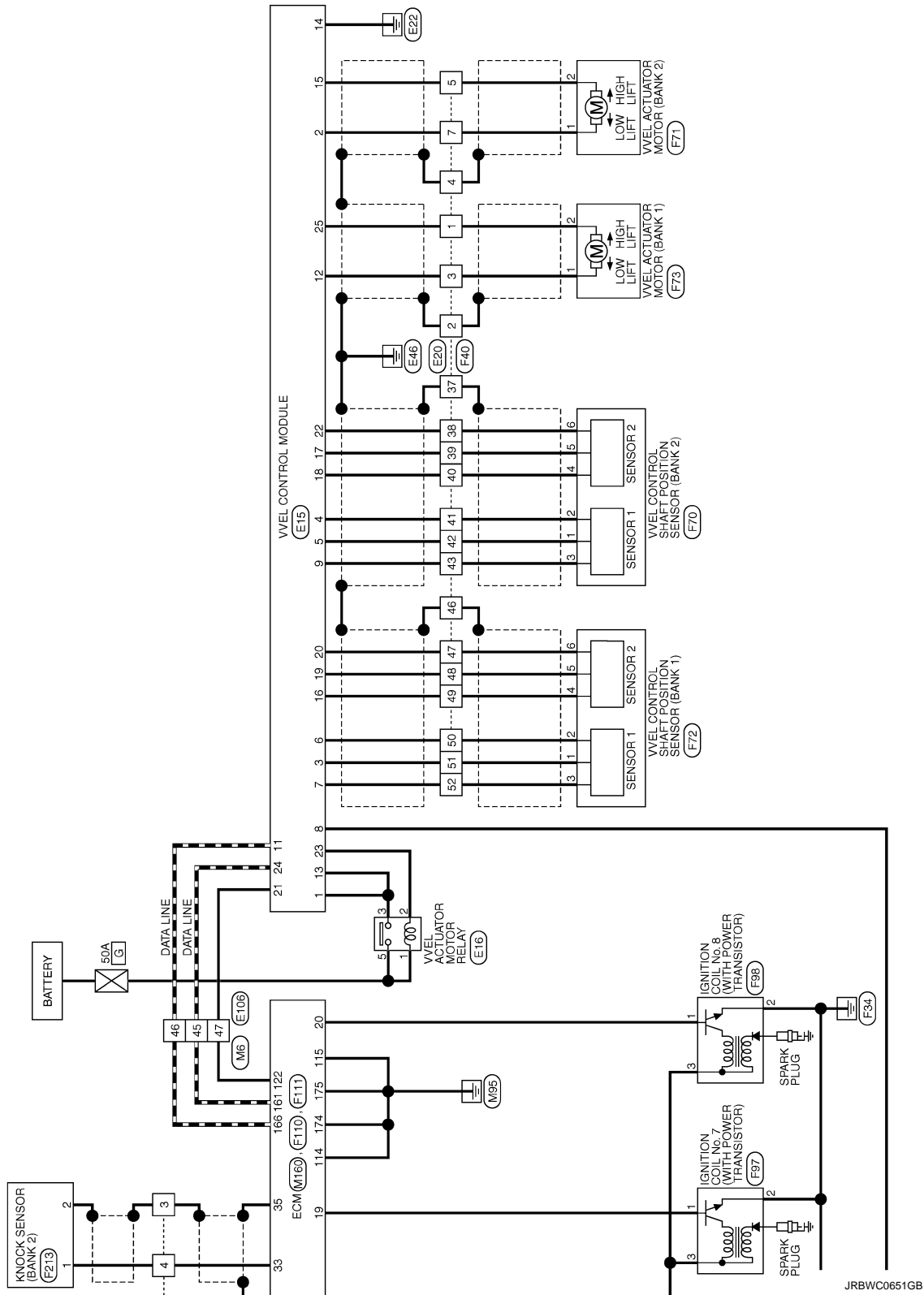

JRBWC0651GB

A  
EC  
C  
D  
E  
F  
G  
H  
I  
J  
K  
L  
M  
N  
O  
P

# DIAGNOSIS AND REPAIR WORKFLOW

< BASIC INSPECTION >

[VK56VD FOR USA AND CANADA]

## BASIC INSPECTION

### DIAGNOSIS AND REPAIR WORKFLOW

#### Work Flow

INFOID:000000007187422

#### OVERALL SEQUENCE

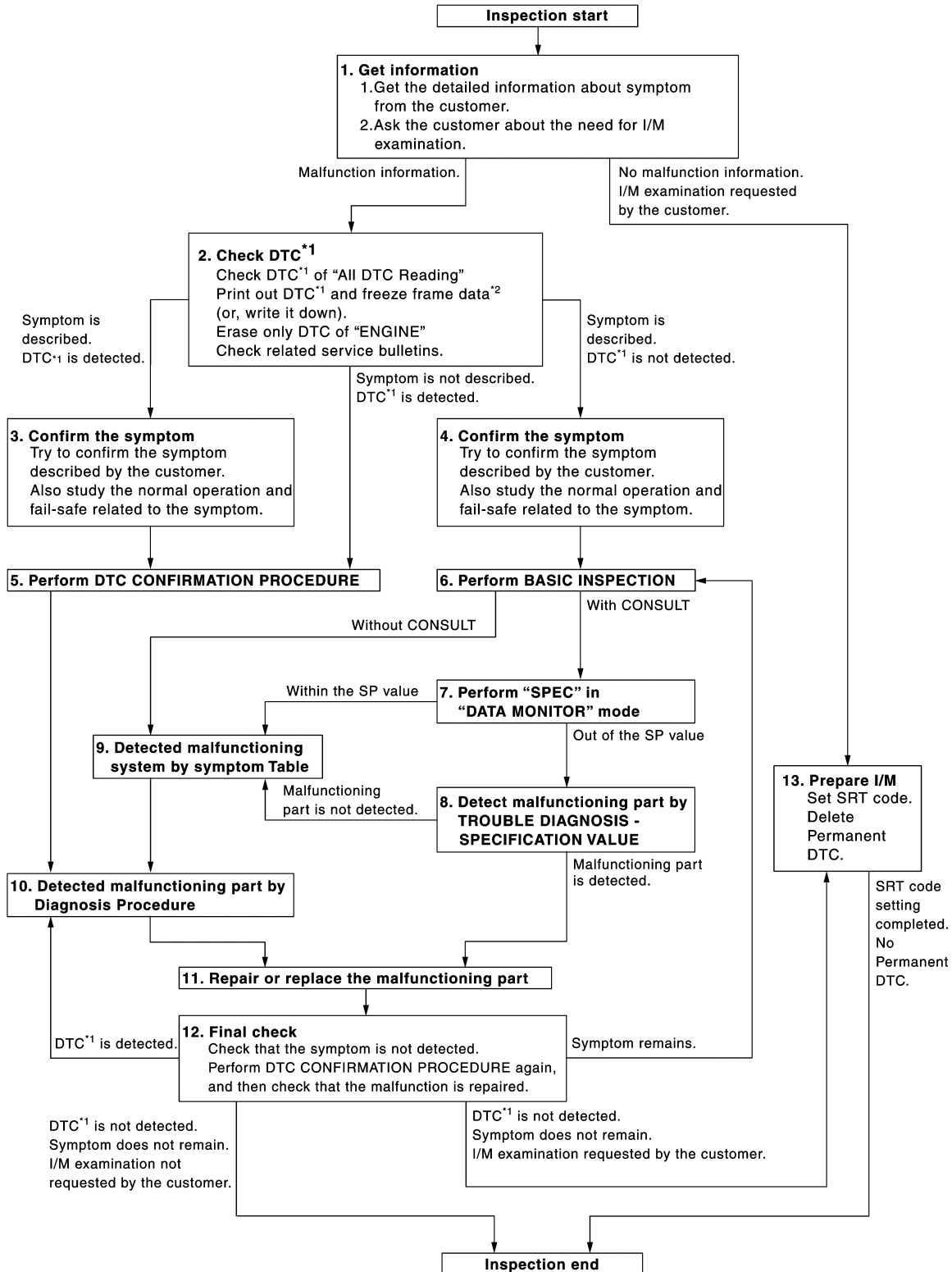

JSBIA0123GB

# DIAGNOSIS AND REPAIR WORKFLOW

< BASIC INSPECTION >

[VK56VD FOR USA AND CANADA]

\*1: Include 1st trip DTC.

\*2: Include 1st trip freeze frame data.

## DETAILED FLOW

### 1. GET INFORMATION FOR SYMPTOM

1. Get the detailed information from the customer about the symptom (the condition and the environment when the incident/malfunction occurred) using the "Diagnostic Work Sheet". (Refer to [EC-1111, "Diagnostic Work Sheet"](#).)
2. Ask if the customer requests I/M examination.

Malfunction information, obtained>>GO TO 2.

No malfunction information, but a request for I/M examination>>GO TO 13.

### 2. CHECK DTC

1. Check DTC.
2. Perform the following procedure if DTC is displayed.
  - Record DTC and freeze frame data. (Print them out with CONSULT or GST.)
  - Erase DTC.
  - Study the relationship between the cause detected by DTC and the symptom described by the customer. (Symptom Matrix Chart is useful. Refer to [EC-1541, "Symptom Table"](#).)
3. Check related service bulletins for information.

Are any symptoms described and any DTCs detected?

Symptom is described, DTC is detected>>GO TO 3.

Symptom is described, DTC is not detected>>GO TO 4.

Symptom is not described, DTC is detected>>GO TO 5.

### 3. CONFIRM THE SYMPTOM

Try to confirm the symptom described by the customer (except MIL ON).

Also study the normal operation and fail-safe related to the symptom. Refer to [EC-1547, "Description"](#) and [EC-1078, "Fail-safe"](#).

Diagnosis Work Sheet is useful to verify the incident.

Verify relation between the symptom and the condition when the symptom is detected.

>> GO TO 5.

### 4. CONFIRM THE SYMPTOM

Try to confirm the symptom described by the customer.

Also study the normal operation and fail-safe related to the symptom. Refer to [EC-1541, "Symptom Table"](#) and [EC-1078, "Fail-safe"](#).

Diagnosis Work Sheet is useful to verify the incident.

Verify relation between the symptom and the condition when the symptom is detected.

>> GO TO 6.

### 5. PERFORM DTC CONFIRMATION PROCEDURE

Perform DTC CONFIRMATION PROCEDURE for the displayed DTC, and then check that DTC is detected again.

If two or more DTCs are detected, refer to [EC-1081, "DTC Inspection Priority Chart"](#) and determine trouble diagnosis order.

#### NOTE:

- Freeze frame data is useful if the DTC is not detected.
- Perform Component Function Check if DTC CONFIRMATION PROCEDURE is not included on Service Manual. This simplified check procedure is an effective alternative though DTC cannot be detected during this check.

If the result of Component Function Check is NG, it is the same as the detection of DTC by DTC CONFIRMATION PROCEDURE.

Is DTC detected?

# DIAGNOSIS AND REPAIR WORKFLOW

[VK56VD FOR USA AND CANADA]

< BASIC INSPECTION >

- YES >> GO TO 10.  
NO >> Check according to [GI-44, "Intermittent Incident"](#).

## 6. PERFORM BASIC INSPECTION

Perform [EC-1113, "Work Procedure"](#).

Will CONSULT be used?

- YES >> GO TO 7.  
NO >> GO TO 9.

## 7. PERFORM SPEC IN DATA MONITOR MODE

Ⓟ With CONSULT

Check that "MAS A/F SE-B1", "MAS A/F SE-B2", "B/FUEL SCHDL", "A/F ALPHA-B1" and "A/F ALPHA-B2" are within the SP value using "SPEC" in "DATA MONITOR" mode with CONSULT. Refer to [EC-1142, "Component Function Check"](#).

Is the measurement value within the SP value?

- YES >> GO TO 9.  
NO >> GO TO 8.

## 8. DETECT MALFUNCTIONING PART BY TROUBLE DIAGNOSIS - SPECIFICATION VALUE

Detect malfunctioning part according to [EC-1143, "Diagnosis Procedure"](#).

Is a malfunctioning part detected?

- YES >> GO TO 11.  
NO >> GO TO 9.

## 9. DETECT MALFUNCTIONING SYSTEM BY SYMPTOM TABLE

Detect malfunctioning system according to [EC-1541, "Symptom Table"](#) based on the confirmed symptom in step 4, and determine the trouble diagnosis order based on possible causes and symptoms.

>> GO TO 10.

## 10. DETECT MALFUNCTIONING PART BY DIAGNOSIS PROCEDURE

Inspect according to Diagnosis Procedure of the system.

### NOTE:

The Diagnosis Procedure in EC section described based on open circuit inspection. A short circuit inspection is also required for the circuit check in the Diagnosis Procedure. For details, refer to [GI-47, "Circuit Inspection"](#).

Is a malfunctioning part detected?

- YES >> GO TO 11.  
NO >> Monitor input data from related sensors or check voltage of related ECM terminals using CONSULT. Refer to [EC-1055, "Reference Value"](#).

## 11. REPAIR OR REPLACE THE MALFUNCTIONING PART

1. Repair or replace the malfunctioning part.
2. Reconnect parts or connectors disconnected during Diagnosis Procedure again after repair and replacement.
3. Check DTC. If DTC is displayed, erase it.

>> GO TO 12.

## 12. FINAL CHECK

When DTC was detected in step 2, perform DTC CONFIRMATION PROCEDURE or Component Function Check again, and then check that the malfunction have been completely repaired.

When symptom was described from the customer, refer to confirmed symptom in step 3 or 4, and check that the symptom is not detected.

Is DTC detected and does symptom remain?

- YES-1 >> DTC is detected: GO TO 10.  
YES-2 >> Symptom remains: GO TO 6.

# DIAGNOSIS AND REPAIR WORKFLOW

[VK56VD FOR USA AND CANADA]

## < BASIC INSPECTION >

NO-1 >> Before returning the vehicle to the customer, always erase unnecessary DTC in ECM and TCM (Transmission Control Module). If the completion of SRT is needed, drive vehicle under the specific driving pattern. Refer to [EC-1130, "Description"](#).

NO-2 >> I/M examination, requested from the customer: GO TO 13.

## 13. PREPARE FOR I/M EXAMINATION

1. Set SRT codes. Refer to [EC-1130, "Description"](#).
2. Erase permanent DTCs. Refer to [EC-1136, "Description"](#).

>> INSPECTION END

## Diagnostic Work Sheet

INFOID:000000007187423

### DESCRIPTION

There are many operating conditions that lead to the malfunction of engine components. A good grasp of such conditions can make troubleshooting faster and more accurate.

In general, each customer feels differently about symptoms. It is important to fully understand the symptoms or conditions for a customer complaint.

Utilize a diagnostic worksheet like the WORKSHEET SAMPLE below in order to organize all the information for troubleshooting.

Some conditions may cause the MIL to illuminate or blink, and DTC to be detected. Examples:

- Vehicle ran out of fuel, which caused the engine to misfire.
- Fuel filler cap was left off or incorrectly screwed on, allowing fuel to evaporate into the atmosphere.

### KEY POINTS

**WHAT** ..... Vehicle & engine model  
**WHEN** ..... Date, Frequencies  
**WHERE**..... Road conditions  
**HOW** ..... Operating conditions,  
Weather conditions,  
Symptoms

SEF907L

# DIAGNOSIS AND REPAIR WORKFLOW

< BASIC INSPECTION >

[VK56VD FOR USA AND CANADA]

## WORKSHEET SAMPLE

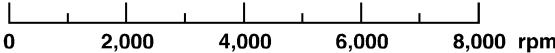
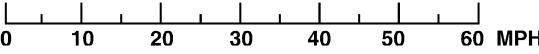
|                            |                                       |  |  |
|----------------------------|---------------------------------------|--|--|
| Customer name MR/MS        |                                       | Model & Year   | VIN  |
| Engine #                   |                                       | Trans.   | Mileage  |
| Incident Date              |                                       | Manuf. Date  | In Service Date  |
| Fuel and fuel filler cap   |                                       | <input type="checkbox"/> Vehicle ran out of fuel causing misfire<br><input type="checkbox"/> Fuel filler cap was left off or incorrectly screwed on.   |  |
| Symptoms                   | <input type="checkbox"/> Startability | <input type="checkbox"/> Impossible to start <input type="checkbox"/> No combustion <input type="checkbox"/> Partial combustion<br><input type="checkbox"/> Partial combustion affected by throttle position<br><input type="checkbox"/> Partial combustion NOT affected by throttle position<br><input type="checkbox"/> Possible but hard to start <input type="checkbox"/> Others [                      ]  |  |
|                            | <input type="checkbox"/> Idling       | <input type="checkbox"/> No fast idle <input type="checkbox"/> Unstable <input type="checkbox"/> High idle <input type="checkbox"/> Low idle<br><input type="checkbox"/> Others [                      ]   |  |
|                            | <input type="checkbox"/> Driveability | <input type="checkbox"/> Stumble <input type="checkbox"/> Surge <input type="checkbox"/> Knock <input type="checkbox"/> Lack of power<br><input type="checkbox"/> Intake backfire <input type="checkbox"/> Exhaust backfire<br><input type="checkbox"/> Others [                      ]  |  |
|                            | <input type="checkbox"/> Engine stall | <input type="checkbox"/> At the time of start <input type="checkbox"/> While idling<br><input type="checkbox"/> While accelerating <input type="checkbox"/> While decelerating<br><input type="checkbox"/> Just after stopping <input type="checkbox"/> While loading  |  |
| Incident occurrence        |                                       | <input type="checkbox"/> Just after delivery <input type="checkbox"/> Recently<br><input type="checkbox"/> In the morning <input type="checkbox"/> At night <input type="checkbox"/> In the daytime  |  |
| Frequency                  |                                       | <input type="checkbox"/> All the time <input type="checkbox"/> Under certain conditions <input type="checkbox"/> Sometimes   |  |
| Weather conditions         |                                       | <input type="checkbox"/> Not affected  |  |
|                            |                                       | Weather  | <input type="checkbox"/> Fine <input type="checkbox"/> Raining <input type="checkbox"/> Snowing <input type="checkbox"/> Others [                      ]   |
|                            |                                       | Temperature  | <input type="checkbox"/> Hot <input type="checkbox"/> Warm <input type="checkbox"/> Cool <input type="checkbox"/> Cold <input type="checkbox"/> Humid   °F |
| Engine conditions          |                                       | <input type="checkbox"/> Cold <input type="checkbox"/> During warm-up <input type="checkbox"/> After warm-up<br><br>Engine speed<br>   |  |
| Road conditions            |                                       | <input type="checkbox"/> In town <input type="checkbox"/> In suburbs <input type="checkbox"/> Highway <input type="checkbox"/> Off road (up/down)  |  |
| Driving conditions         |                                       | <input type="checkbox"/> Not affected<br><input type="checkbox"/> At starting <input type="checkbox"/> While idling <input type="checkbox"/> At racing<br><input type="checkbox"/> While accelerating <input type="checkbox"/> While cruising<br><input type="checkbox"/> While decelerating <input type="checkbox"/> While turning (RH/LH)<br><br>Vehicle speed<br> |  |
| Malfunction indicator lamp |                                       | <input type="checkbox"/> Turned on <input type="checkbox"/> Not turned on  |  |

MTBL0017



**BASIC INSPECTION**

**Work Procedure**

INFOID:000000007187424

**1.INSPECTION START**

1. Check service records for any recent repairs that may indicate a related malfunction, or a current need for scheduled maintenance.
2. Open engine hood and check the following:
  - Harness connectors for improper connections
  - Wiring harness for improper connections, pinches and cut
  - Vacuum hoses for splits, kinks and improper connections
  - Hoses and ducts for leakage
  - Air cleaner clogging
  - Gasket
3. Check that electrical or mechanical loads are not applied.
  - Headlamp switch is OFF.
  - Air conditioner switch is OFF.
  - Rear window defogger switch is OFF.
  - Steering wheel is in the straight-ahead position, etc.
4. Start engine and warm it up until engine coolant temperature indicator points to the middle of gauge. Check that engine stays below 1,000 rpm.

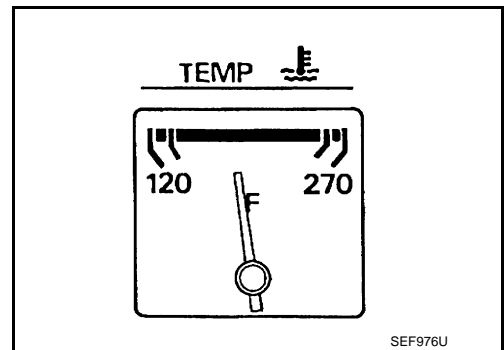
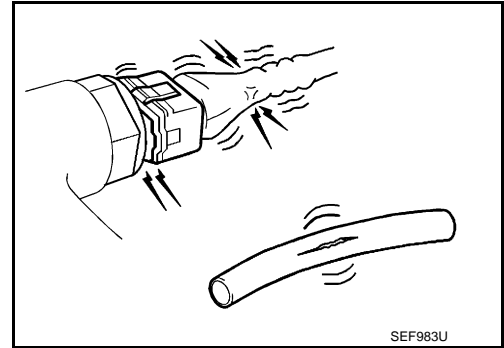

5. Run engine at approximately 2,000 rpm for approximately 2 minutes under no load.
6. Check that no DTC is displayed with CONSULT or GST.

Are any DTCs detected?

- YES >> GO TO 2.
- NO >> GO TO 3.

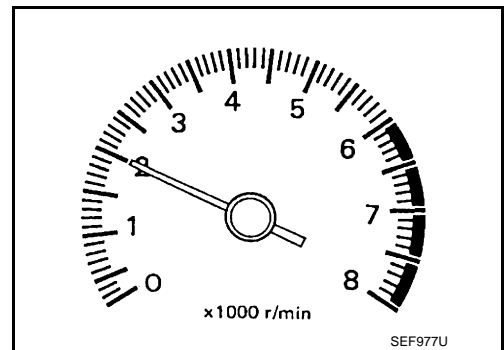

**2.REPAIR OR REPLACE**

Repair or replace components as necessary according to corresponding Diagnosis Procedure.

>> GO TO 3

**3.CHECK IDLE SPEED**

1. Run engine at approximately 2,000 rpm for approximately 2 minutes under no load.

A  
EC  
C  
D  
E  
F  
G  
H  
I  
J  
K  
L  
M  
N  
O  
P

# BASIC INSPECTION

[VK56VD FOR USA AND CANADA]

## < BASIC INSPECTION >

- Rev engine between 2,000 and 3,000 rpm 2 or 3 times under no load, then run engine at idle speed for approximately 1 minute.
- Check idle speed.  
For procedure, refer to [EC-1548, "Inspection"](#).  
For specification, refer to [EC-1556, "Idle Speed"](#).

Is the inspection result normal?

- YES >> GO TO 10.  
NO >> GO TO 4.

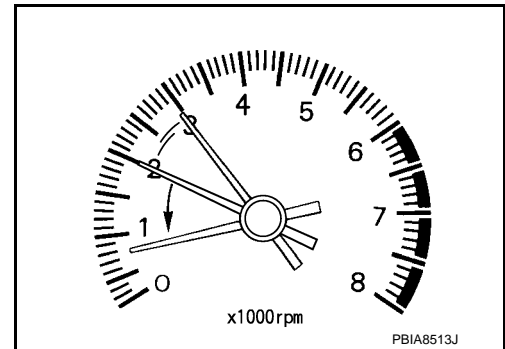

## 4.PERFORM ACCELERATOR PEDAL RELEASED POSITION LEARNING

- Stop engine.
- Perform [EC-1120, "Work Procedure"](#).

>> GO TO 5.

## 5.PERFORM THROTTLE VALVE CLOSED POSITION LEARNING

Perform [EC-1121, "Work Procedure"](#).

>> GO TO 6.

## 6.PERFORM IDLE AIR VOLUME LEARNING

Perform [EC-1122, "Work Procedure"](#).

Is Idle Air Volume Learning carried out successfully?

- YES >> GO TO 7.  
NO >> Follow the instruction of Idle Air Volume Learning. Then GO TO 4.

## 7.CHECK IDLE SPEED AGAIN

- Start engine and warm it up to normal operating temperature.
- Check idle speed.  
For procedure, refer to [EC-1548, "Inspection"](#).  
For specification, refer to [EC-1556, "Idle Speed"](#).

Is the inspection result normal?

- YES >> GO TO 10.  
NO >> GO TO 8.

## 8.DETECT MALFUNCTIONING PART

Check the Following.

- Check camshaft position sensor and circuit. Refer to [EC-1309, "DTC Logic"](#).
- Check crankshaft position sensor and circuit. Refer to [EC-1305, "DTC Logic"](#).

Is the inspection result normal?

- YES >> GO TO 9.  
NO >> Repair or replace malfunctioning part. Then GO TO 4.

## 9.CHECK ECM FUNCTION

- Substitute with a non-malfunctioning ECM to check ECM function. (ECM may be the cause of the incident, although this is rare.)
- Perform initialization of IVIS (NATS) system and registration of all IVIS (NATS) ignition key IDs. Refer to [SEC-39, "ECM : Work Procedure"](#).

>> GO TO 4.

## 10.CHECK IGNITION TIMING

- Run engine at idle.
- Check ignition timing with a timing light.  
For procedure, refer to [EC-1549, "Inspection"](#).

# BASIC INSPECTION

[VK56VD FOR USA AND CANADA]

< BASIC INSPECTION >

For specification, refer to [EC-1556, "Ignition Timing"](#).

Is the inspection result normal?

- YES >> GO TO 19.  
NO >> GO TO 11.

## 11.PERFORM ACCELERATOR PEDAL RELEASED POSITION LEARNING

1. Stop engine.
2. Perform [EC-1120, "Work Procedure"](#).

>> GO TO 12.

## 12.PERFORM THROTTLE VALVE CLOSED POSITION LEARNING

Perform [EC-1121, "Work Procedure"](#).

>> GO TO 13.

## 13.PERFORM IDLE AIR VOLUME LEARNING

Perform [EC-1122, "Work Procedure"](#).

Is Idle Air Volume Learning carried out successfully?

- YES >> GO TO 14.  
NO >> Follow the instruction of Idle Air Volume Learning. Then GO TO 4.

## 14.CHECK IDLE SPEED AGAIN

1. Start engine and warm it up to normal operating temperature.
2. Check idle speed.  
For procedure, refer to [EC-1548, "Inspection"](#).  
For specification, refer to [EC-1556, "Idle Speed"](#).

Is the inspection result normal?

- YES >> GO TO 15.  
NO >> GO TO 17.

## 15.CHECK IGNITION TIMING AGAIN

1. Run engine at idle.
2. Check ignition timing with a timing light.  
For procedure, refer to [EC-1549, "Inspection"](#).  
For specification, refer to [EC-1556, "Ignition Timing"](#).

Is the inspection result normal?

- YES >> GO TO 19.  
NO >> GO TO 16.

## 16.CHECK TIMING CHAIN INSTALLATION

Check timing chain installation. Refer to [EM-244, "Inspection"](#).

Is the inspection result normal?

- YES >> GO TO 17.  
NO >> Repair the timing chain installation. Then GO TO 4.

## 17.DETECT MALFUNCTIONING PART

Check the following.

- Check camshaft position sensor and circuit. Refer to [EC-1309, "DTC Logic"](#).
- Check crankshaft position sensor and circuit. Refer to [EC-1305, "DTC Logic"](#).

Is the inspection result normal?

- YES >> GO TO 18.  
NO >> Repair or replace malfunctioning part. Then GO TO 4.

## 18.CHECK ECM FUNCTION

1. Substitute with a non-malfunctioning ECM to check ECM function. (ECM may be the cause of the incident, although this is rare.)

A

EC

C

D

E

F

G

H

I

J

K

L

M

N

O

P

## BASIC INSPECTION

< BASIC INSPECTION >

[VK56VD FOR USA AND CANADA]

---

2. Perform initialization of IVIS (NATS) system and registration of all IVIS (NATS) ignition key IDs. Refer to .

>> GO TO 4.

**19.**INSPECTION END

---

If ECM is replaced during this BASIC INSPECTION procedure, perform [EC-1117. "Work Procedure"](#).

>> INSPECTION END

# ADDITIONAL SERVICE WHEN REPLACING ECM

< BASIC INSPECTION >

[VK56VD FOR USA AND CANADA]

## ADDITIONAL SERVICE WHEN REPLACING ECM

### Description

INFOID:000000007187425

When replacing ECM, the following procedure must be performed.

### Work Procedure

INFOID:000000007187426

**1.**PERFORM INITIALIZATION OF IVIS (NATS) SYSTEM AND REGISTRATION OF ALL IVIS (NATS) IGNITION KEY IDS

Perform initialization of IVIS (NATS) system and registration of all IVIS (NATS) ignition key IDs. Refer to [SEC-39, "ECM : Work Procedure"](#).

>> GO TO 2.

**2.**PERFORM VIN REGISTRATION

Perform VIN registration. Refer to [EC-1119, "Work Procedure"](#).

>> GO TO 3.

**3.**PERFORM ACCELERATOR PEDAL RELEASED POSITION LEARNING

Perform accelerator pedal released position learning. Refer to [EC-1120, "Work Procedure"](#).

>> GO TO 4.

**4.**PERFORM THROTTLE VALVE CLOSED POSITION LEARNING

Perform throttle valve closed position learning. Refer to [EC-1121, "Work Procedure"](#).

>> GO TO 5.

**5.**PERFORM IDLE AIR VOLUME LEARNING

Perform idle air volume learning. Refer to [EC-1122, "Work Procedure"](#).

>> WORK END

A

EC

C

D

E

F

G

H

I

J

K

L

M

N

O

P

## ADDITIONAL SERVICE WHEN REPLACING VVEL CONTROL MODULE

< BASIC INSPECTION >

[VK56VD FOR USA AND CANADA]

---

## ADDITIONAL SERVICE WHEN REPLACING VVEL CONTROL MODULE

### Description

INFOID:000000007187427

When replacing VVEL control module, the following procedure must be performed.

### Work Procedure

INFOID:000000007187428

#### 1. PERFORM IDLE AIR VOLUME LEARNING

---

Perform idle air volume learning. Refer to [EC-1122, "Work Procedure"](#).

>> WORK END

# VIN REGISTRATION

< BASIC INSPECTION >

[VK56VD FOR USA AND CANADA]

## VIN REGISTRATION

### Description

INFOID:000000007187429

VIN Registration is an operation to register VIN in ECM. It must be performed each time ECM is replaced.

#### NOTE:

Accurate VIN which is registered in ECM may be required for Inspection & Maintenance (I/M).

### Work Procedure

INFOID:000000007187430

#### 1. CHECK VIN

Check the VIN of the vehicle and note it. Refer to [GI-35. "Information About Identification or Model Code"](#).

>> GO TO 2.

#### 2. PERFORM VIN REGISTRATION

 With CONSULT

1. Turn ignition switch ON with engine stopped.
2. Select "VIN REGISTRATION" in "WORK SUPPORT" mode.
3. Follow the instructions on the CONSULT display.

>> END

A

EC

C

D

E

F

G

H

I

J

K

L

M

N

O

P

# ACCELERATOR PEDAL RELEASED POSITION LEARNING

< BASIC INSPECTION >

[VK56VD FOR USA AND CANADA]

---

## ACCELERATOR PEDAL RELEASED POSITION LEARNING

### Description

INFOID:000000007187431

Accelerator Pedal Released Position Learning is a function of ECM to learn the fully released position of the accelerator pedal by monitoring the accelerator pedal position sensor output signal. It must be performed each time the harness connector of the accelerator pedal position sensor or ECM is disconnected.

### Work Procedure

INFOID:000000007187432

#### 1. START

---

1. Check that accelerator pedal is fully released.
2. Turn ignition switch ON and wait at least 2 seconds.
3. Turn ignition switch OFF and wait at least 10 seconds.
4. Turn ignition switch ON and wait at least 2 seconds.
5. Turn ignition switch OFF and wait at least 10 seconds.

>> END



# THROTTLE VALVE CLOSED POSITION LEARNING

< BASIC INSPECTION >

[VK56VD FOR USA AND CANADA]

## THROTTLE VALVE CLOSED POSITION LEARNING

### Description

INFOID:000000007187433

Throttle Valve Closed Position Learning is a function of ECM to learn the fully closed position of the throttle valve by monitoring the throttle position sensor output signal. It must be performed each time the harness connector of the electric throttle control actuator or ECM is disconnected or electric throttle control actuator inside is cleaned.

### Work Procedure

INFOID:000000007187434

#### 1. START

##### ④ With CONSULT

1. Turn ignition switch ON.
2. Select "CLSD THL POS LEARN" in "WORK SUPPORT" mode.
3. Follow the instructions on the CONSULT display.
4. Turn ignition switch OFF and wait at least 10 seconds.  
Check that throttle valve moves during the above 10 seconds by confirming the operating sound.

##### ⊗ Without CONSULT

1. Start the engine.  
**NOTE:**  
Engine coolant temperature is 25°C (77°F) or less before engine starts.
2. Warm up the engine.  
**NOTE:**  
Raise engine coolant temperature until it reaches 65°C (149°F) or more.
3. Turn ignition switch OFF and wait at least 10 seconds.  
Check that throttle valve moves during the above 10 seconds by confirming the operating sound.

>> END

A  
EC  
C  
D  
E  
F  
G  
H  
I  
J  
K  
L  
M  
N  
O  
P

## IDLE AIR VOLUME LEARNING

### Description

INFOID:000000007187435

Idle Air Volume Learning is a function of ECM to learn the idle air volume that keeps engine idle speed within the specific range. It must be performed under the following conditions:

- Each time the electric throttle control actuator or ECM is replaced.
- Idle speed or ignition timing is out of the specification.

### Work Procedure

INFOID:000000007187436

#### 1. PRECONDITIONING

Check that all of the following conditions are satisfied.

Learning will be cancelled if any of the following conditions are missed for even a moment.

- Battery voltage: More than 12.9 V (At idle)
- Engine coolant temperature: 70 - 105°C (158 - 221°F)
- Selector lever position: P or N
- Electric load switch: OFF  
(Air conditioner, headlamp, rear window defogger)

**On vehicles equipped with daytime light systems, if the parking brake is applied before the engine is started the headlamp will not illuminate.**

- Steering wheel: Neutral (Straight-ahead position)
- Vehicle speed: Stopped
- Transmission: Warmed-up
- With CONSULT: Drive vehicle until "ATF TEMP 2" in "DATA MONITOR" mode of "A/T" system indicates less than 0.9 V.
- Without CONSULT: Drive vehicle for 10 minutes.

Will CONSULT be used?

- YES >> GO TO 2.
- NO >> GO TO 3.

#### 2. PERFORM IDLE AIR VOLUME LEARNING

With CONSULT

1. Perform Accelerator Pedal Released Position Learning. Refer to [EC-1120, "Work Procedure"](#).
2. Perform Throttle Valve Closed Position Learning. [EC-1121, "Work Procedure"](#).
3. Start engine and warm it up to normal operating temperature.
4. Select "IDLE AIR VOL LEARN" in "WORK SUPPORT" mode.
5. Touch "START" and wait 20 seconds.

Is "CMPLT" displayed on CONSULT screen?

- YES >> GO TO 4.
- NO >> GO TO 5.

#### 3. PERFORM IDLE AIR VOLUME LEARNING

Without CONSULT

**NOTE:**

- **It is better to count the time accurately with a clock.**
- **It is impossible to switch the diagnostic mode when an accelerator pedal position sensor circuit has a malfunction.**

1. Perform Accelerator Pedal Released Position Learning. Refer to [EC-1120, "Work Procedure"](#).
2. Perform Throttle Valve Closed Position Learning. [EC-1121, "Work Procedure"](#).
3. Start engine and warm it up to normal operating temperature.
4. Turn ignition switch OFF and wait at least 10 seconds.
5. Confirm that accelerator pedal is fully released, turn ignition switch ON and wait 3 seconds.
6. Repeat the following procedure quickly 5 times within 5 seconds.
  - Fully depress the accelerator pedal.
  - Fully release the accelerator pedal.
7. Wait 7 seconds, fully depress the accelerator pedal for approx. 20 seconds until the MIL stops blinking and turns ON.
8. Fully release the accelerator pedal within 3 seconds after the MIL turns ON.

# IDLE AIR VOLUME LEARNING

[VK56VD FOR USA AND CANADA]

< BASIC INSPECTION >

9. Start engine and let it idle.
10. Wait 20 seconds.

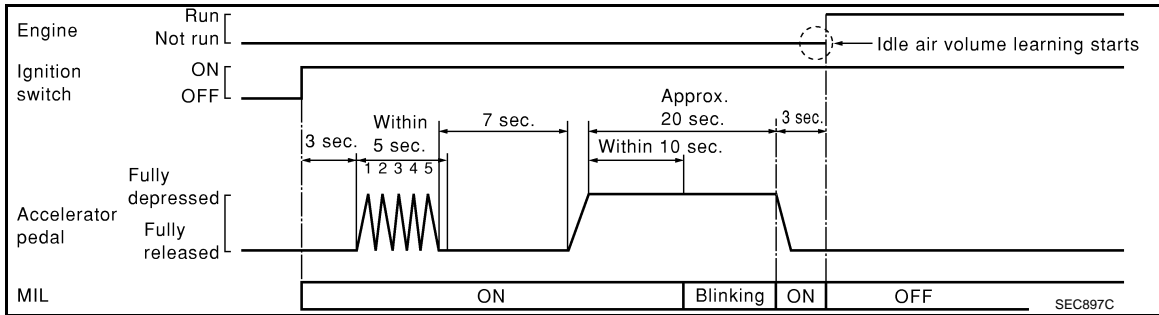

>> GO TO 4.

## 4. CHECK IDLE SPEED AND IGNITION TIMING

Rev up engine two or three times and check that idle speed and ignition timing are within the specifications. For procedure, refer to [EC-1556. "Idle Speed"](#) and [EC-1556. "Ignition Timing"](#). For specifications, refer to [EC-1556. "Idle Speed"](#) and [EC-1556. "Ignition Timing"](#).

Is the inspection result normal?

- YES >> INSPECTION END
- NO >> GO TO 5.

## 5. DETECT MALFUNCTIONING PART-I

Check the following

- Check that throttle valve is fully closed.
- Check PCV valve operation.
- Check that downstream of throttle valve is free from air leakage.

Is the inspection result normal?

- YES >> GO TO 6.
- NO >> Repair or replace malfunctioning part.

## 6. DETECT MALFUNCTIONING PART-II

Engine component parts and their installation condition are questionable. Check and eliminate the cause of the incident.

It is useful to perform "TROUBLE DIAGNOSIS - SPECIFICATION VALUE". Refer to [EC-1142. "Description"](#). If any of the following conditions occur after the engine has started, eliminate the cause of the incident and perform Idle Air Volume Learning again:

- Engine stalls.
- Incorrect idle.

>> INSPECTION END

# VVEL CONTROL SHAFT POSITION SENSOR ADJUSTMENT

< BASIC INSPECTION >

[VK56VD FOR USA AND CANADA]

## VVEL CONTROL SHAFT POSITION SENSOR ADJUSTMENT

### Description

INFOID:000000007187437

VVEL control shaft position sensor adjustment is an operation to adjust the initial position of the VVEL control shaft position sensor.

It must be performed each time VVEL actuator sub assembly is replaced.

#### CAUTION:

- It must be performed only on the replaced bank side.
- It must not be performed except when VVEL actuator sub assembly is replaced. If by any chance the adjustment is performed, replace VVEL actuator sub assembly.

### Work Procedure

INFOID:000000007187438

#### 1. START

Will CONSULT be used?

Will CONSULT be used?

YES >> GO TO 2.

NO >> GO TO 3.

#### 2. PERFORM VVEL CONTROL SHAFT POSITION SENSOR ADJUSTMENT

##### Ⓟ With CONSULT

1. Turn ignition switch ON.
2. Select "VVEL POS SEN ADJ PREP" in "WORK SUPPORT" mode with CONSULT.
3. Touch "Start" and wait a few seconds.
4. Check that "CMPLT" is displayed on CONSULT screen.
5. Select "VVEL POSITION SEN-B1" or "VVEL POSITION SEN-B2" in "DATA MONITOR" mode with CONSULT.
6. Loosen the VVEL control shaft position sensor mounting bolts (1).
7. Turn the VVEL control shaft position sensor (2) clockwise and counterclockwise while monitoring the output voltage of "VVEL POSITION SEN-B1" or "VVEL POSITION SEN-B2" and adjust the output voltage to be within the standard value.

**Voltage: 500 ± 48 mV**

8. Tighten the VVEL control shaft position sensor mounting bolts.

**Ⓜ: 7.0 N•m (0.71 kg•m, 62 in•lb)**

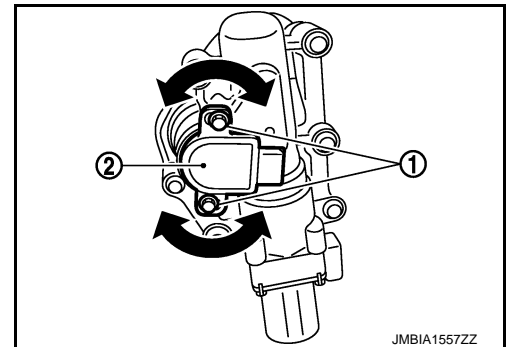

9. Reconfirm that the output voltage of "VVEL POSITION SEN-B1" or "VVEL POSITION SEN-B2" is within the standard value.

**Voltage: 500 ± 48 mV**

#### NOTE:

If it varies from the standard value after the mounting bolts are tightened, perform steps 6 to 8 again.

10. Turn ignition switch OFF and wait at least 10 seconds.
11. Start engine and warm it up to normal operating temperature.
12. Turn ignition switch OFF and wait at least 10 seconds.
13. Perform idle air volume learning. Refer to [EC-1122, "Work Procedure"](#).

>> INSPECTION END

#### 3. PERFORM VVEL CONTROL SHAFT POSITION SENSOR ADJUSTMENT

##### ⓧ Without CONSULT

1. Disconnect VVEL control shaft position sensor harness connector.
2. Remove VVEL actuator motor relay.
3. Turn ignition switch ON, wait at least 5 seconds and then turn it OFF.

# VVEL CONTROL SHAFT POSITION SENSOR ADJUSTMENT

[VK56VD FOR USA AND CANADA]

## < BASIC INSPECTION >

4. Reconnect all harness connectors disconnected.
5. Install VVEL actuator motor relay.
6. Turn ignition switch ON and wait at least 5 seconds.
7. Loosen the VVEL control shaft position sensor mounting bolts (1).
8. Turn the VVEL control shaft position sensor (2) clockwise and counterclockwise while monitoring the output voltage between the VVEL control module terminals with a tester and adjust the output voltage to be within the standard value.

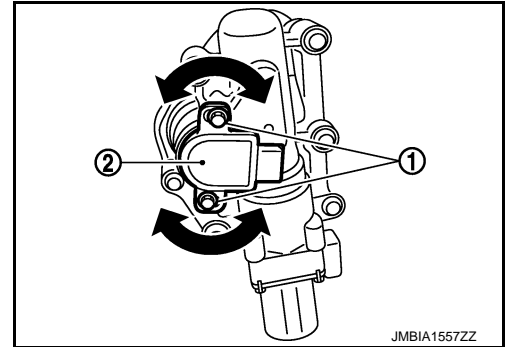

| VVEL control module |           |          |          | Voltage     |
|---------------------|-----------|----------|----------|-------------|
| Bank                | Connector | +        | -        |             |
|                     |           | Terminal | Terminal |             |
| 1                   | E15       | 3        | 6        | 500 ± 48 mV |
| 2                   |           | 5        | 4        |             |

9. Tighten the VVEL control shaft position sensor mounting bolts.



**7.0 N•m (0.71 kg-m, 62 in-lb)**

10. Reconfirm that the output voltage of VVEL control shaft position sensor is within the standard value.

| VVEL control module |           |          |          | Voltage     |
|---------------------|-----------|----------|----------|-------------|
| Bank                | Connector | +        | -        |             |
|                     |           | Terminal | Terminal |             |
| 1                   | E15       | 3        | 6        | 500 ± 48 mV |
| 2                   |           | 5        | 4        |             |

### NOTE:

If it varies from the standard value after the mounting bolts are tightened, perform steps 7 to 9 again.

11. Turn ignition switch OFF and wait at least 10 seconds.
12. Start engine and warm it up to normal operating temperature.
13. Turn ignition switch OFF and wait at least 10 seconds.
14. Perform Idle Air Volume Learning. Refer to [EC-1122, "Work Procedure"](#).

>> INSPECTION END

# MIXTURE RATIO SELF-LEARNING VALUE CLEAR

< BASIC INSPECTION >

[VK56VD FOR USA AND CANADA]

---

## MIXTURE RATIO SELF-LEARNING VALUE CLEAR

### Description

INFOID:000000007187439

This describes how to erase the mixture ratio self-learning value. For the actual procedure, follow the instructions in "Diagnosis Procedure".

### Work Procedure

INFOID:000000007187440

#### 1. START

---

##### With CONSULT

1. Start engine and warm it up to normal operating temperature.
2. Select "SELF-LEARNING CONT" in "WORK SUPPORT" mode with CONSULT.
3. Clear mixture ratio self-learning value by touching "CLEAR".

##### With GST

1. Start engine and warm it up to normal operating temperature.
2. Turn ignition switch OFF.
3. Disconnect mass air flow sensor (bank 1) harness connector.
4. Restart engine and let it idle for at least 5 seconds.
5. Stop engine and reconnect mass air flow sensor (bank 1) harness connector.
6. Select Service \$03 with GST. Check DTC P0102 is detected.
7. Select Service \$04 with GST to erase the DTC P0102.

>> END

## FUEL PRESSURE

### Work Procedure

INFOID:000000007187441

### FUEL PRESSURE RELEASE

#### Ⓜ WITH CONSULT

1. Turn ignition switch ON.
2. Perform "FUEL PRESSURE RELEASE" in "WORK SUPPORT" mode with CONSULT.
3. Start engine.
4. After engine stalls, crank it two or three times to release all fuel pressure.
5. Turn ignition switch OFF.

#### ⓧ WITHOUT CONSULT

1. Remove fuel pump fuse in IPDM E/R.
  - NOTE:**
  - For the fuse number, refer to [EC-1100, "Wiring Diagram"](#).
  - For the fuse arrangement, refer to [PG-41, "Connector and Terminal Arrangement"](#).
2. Start engine.
3. After engine stalls, crank it two or three times to release all fuel pressure.
4. Turn ignition switch OFF.
5. Reinstall fuel pump fuse after servicing fuel system.

### LOW FUEL PRESSURE CHECK

#### CAUTION:

- Before disconnecting fuel line, release fuel pressure from fuel line to eliminate danger.
- The fuel hose connection method used when taking fuel pressure check must not be used for other purposes.
- Be careful not to scratch or put debris around connection area when servicing, so that the quick connector maintains seal ability with O-rings inside.
- Do not perform fuel pressure check with electrical systems operating (i.e. lights, rear defogger, A/C, etc.) Fuel pressure gauge may indicate false readings due to varying engine load and changes in manifold vacuum.

#### NOTE:

Prepare pans or saucers under the disconnected fuel line because the fuel may spill out. The fuel pressure cannot be completely released because this models do not have fuel return system.

1. Release fuel pressure to zero.
2. Prepare fuel hose for fuel pressure check (B) and fuel tube adapter [SST (KV10120000)] (D), then connect fuel pressure gauge (A).

- ⇐ To quick connector
- ← To fuel tube (engine side)
- C : Hose clamp

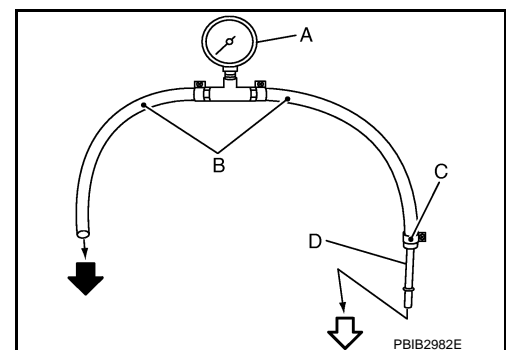

#### CAUTION:

- Use suitable fuel hose for fuel pressure check (genuine NISSAN fuel hose without quick connector).
  - To avoid unnecessary force or tension to hose, use moderately long fuel hose for fuel pressure check.
  - Do not use the fuel hose for checking fuel pressure with damage or cracks on it.
  - Use Pressure Gauge to check fuel pressure.
3. Disconnect fuel feed hose from fuel tube. Refer to [EM-193, "Exploded View"](#).

#### CAUTION:

Do not twist or kink fuel hose because it is plastic hose.

# FUEL PRESSURE

< BASIC INSPECTION >

[VK56VD FOR USA AND CANADA]

- Connect fuel hose for fuel pressure check (1) to fuel tube (engine side) with clamp (2) as shown in the figure.

5 : No.2 spool

**CAUTION:**

- Wipe off oil or dirt from hose insertion part using cloth moistened with gasoline.
- Apply proper amount of gasoline between top of the fuel tube (3) and No.1 spool (4).
- Insert fuel hose for fuel pressure check until it touches the No.1 spool on fuel tube.
- Use NISSAN genuine hose clamp (part number: 16439 N4710 or 16439 40U00).
- When reconnecting fuel line, always use new clamps.
- Use a torque driver to tighten clamps.
- Install hose clamp to the position within 1 - 2 mm (0.04 - 0.08 in).

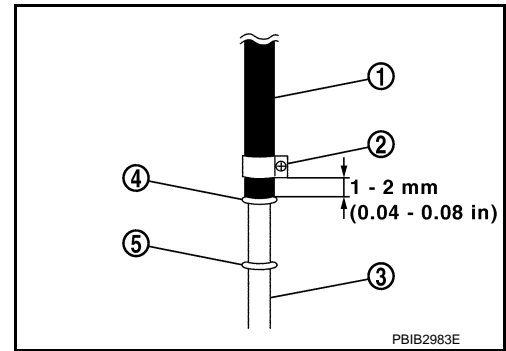

**Tightening torque : 1 - 1.5 N·m (0.1 - 0.15 kg·m, 9 - 13 in·lb)**

- Make sure that clamp screw does not contact adjacent parts.

- Connect fuel tube adapter (C) to quick connector (1).

A : Fuel pressure gauge

B : Fuel hose for fuel pressure check

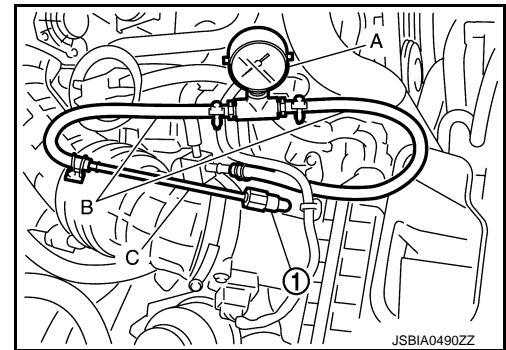

- After connecting fuel hose for fuel pressure check, pull the hose with a force of approximately 98 N (10 kg, 22 lb) to confirm fuel tube does not come off.

- Reinstall the part removed at Step 3.

**NOTE:**

Install the part to allow smooth engine starts.

- Turn ignition switch ON and check for fuel leakage.
- Start engine and check for fuel leakage.
- Read the indication of fuel pressure gauge.

**CAUTION:**

- Do not perform fuel pressure check with system operating. Fuel pressure gauge may indicate false readings.
- During fuel pressure check, confirm for fuel leakage from fuel connection every 3 minutes.

**At idling : Approximately 450 kPa (4.6 kg/cm<sup>2</sup>, 65 psi)**

## HIGH FUEL PRESSURE CHECK

**NOTE:**

Since the fuel pressure gauge kit cannot be connected, follow the method shown below to check high fuel pressure.

Ⓜ WITH CONSULT

- Start engine.
- Check "FUEL PRES SEN V" in "DATA MONITOR" mode with CONSULT.

| Monitor Item    | Condition                                     | Values/Status  |
|-----------------|---|----------------|
| FUEL PRES SEN V | Idle  | 820 – 1,220 mV |
|                 | Revving engine from idle to 4,000 rpm quickly | 820 – 3,060 mV |



# FUEL PRESSURE

< BASIC INSPECTION >

[VK56VD FOR USA AND CANADA]

⊗ WITHOUT CONSULT

1. Start engine.
2. Check the voltage between ECM harness connector and ground.

| ECM       |          |           |          | Condition   | Voltage       |
|-----------|----------|-----------|----------|---|---------------|
| +         |          | -         |          |   |               |
| Connector | Terminal | Connector | Terminal |   |               |
| F110      | 31       | F110      | 40       | [Engine is running]<br>• Warm-up condition<br>• Idle speed                                    | 0.82 – 1,22 V |
|           |          |           |          | [Engine is running]<br>• Warm-up condition<br>• Revving engine from idle to 4,000 rpm quickly | 0.82 – 3,06 V |

A  
EC  
C  
D  
E  
F  
G  
H  
I  
J  
K  
L  
M  
N  
O  
P

# HOW TO SET SRT CODE

< BASIC INSPECTION >

[VK56VD FOR USA AND CANADA]

## HOW TO SET SRT CODE

### Description

INFOID:000000007187442

### OUTLINE

In order to set all SRTs, the self-diagnoses as in the "SRT ITEM" table must have been performed at least once. Each diagnosis may require actual driving for a long period of time under various conditions.

### SRT ITEM

The table below shows required self-diagnostic items to set the SRT to "CMPLT".

| SRT item*1<br>(CONSULT indication) | Required self-diagnostic items to set the SRT to "CMPLT" | Corresponding DTC No.      |
|------------------------------------|--|----------------------------|
| CATALYST                           | Three way catalyst function                              | P0420, P0430               |
| EVAP SYSTEM                        | EVAP control system purge flow monitoring                | P0441                      |
|                                    | EVAP control system                                      | P0456                      |
| HO2S                               | Air fuel ratio (A/F) sensor 1                            | P0130, P0133, P0150, P0153 |
|                                    | Heated oxygen sensor 2                                   | P0137, P0157               |
|                                    | Heated oxygen sensor 2                                   | P0138, P0158               |
|                                    | Heated oxygen sensor 2                                   | P0139, P0159               |
| EGR/VVT SYSTEM                     | Intake valve timing control function                     | P0011, P0021               |

\*1: Though displayed on the CONSULT screen, "HO2S HTR" is not SRT item.

### SRT SERVICE PROCEDURE

# HOW TO SET SRT CODE

< BASIC INSPECTION >

[VK56VD FOR USA AND CANADA]

If a vehicle has failed the state emissions inspection due to one or more SRT items indicating "INCMP", review the flowchart diagnostic sequence on the next page, referring to the following flowchart.

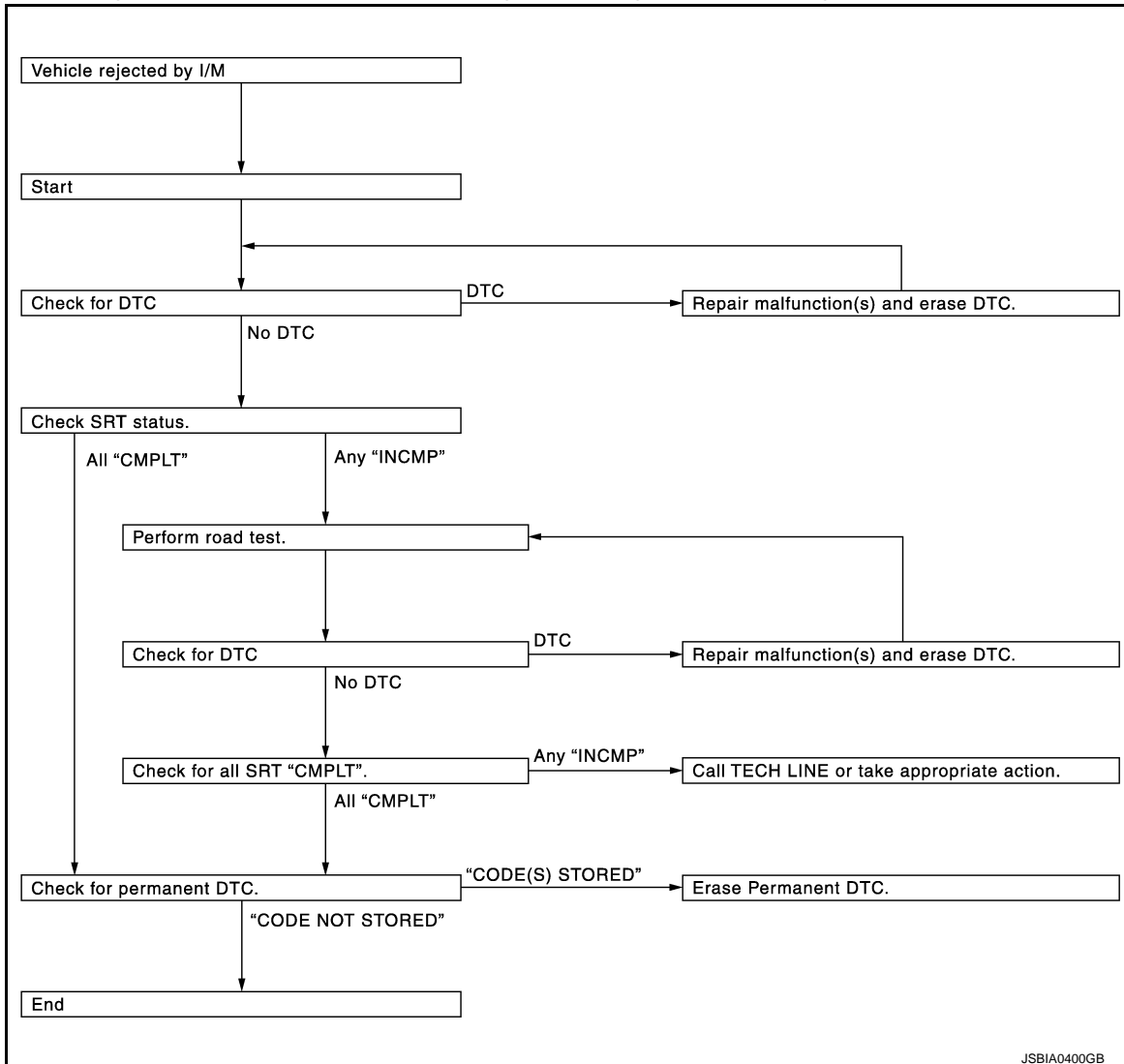

## SRT Set Driving Pattern

INFOID:000000007187443

**CAUTION:**

# HOW TO SET SRT CODE

< BASIC INSPECTION >

[VK56VD FOR USA AND CANADA]

Always drive the vehicle in safe manner according to traffic conditions and obey all traffic laws.

**Note: Always drive vehicle in safe manner according to traffic conditions and obey all traffic laws. Refer to next page for more information and explanation of chart.**

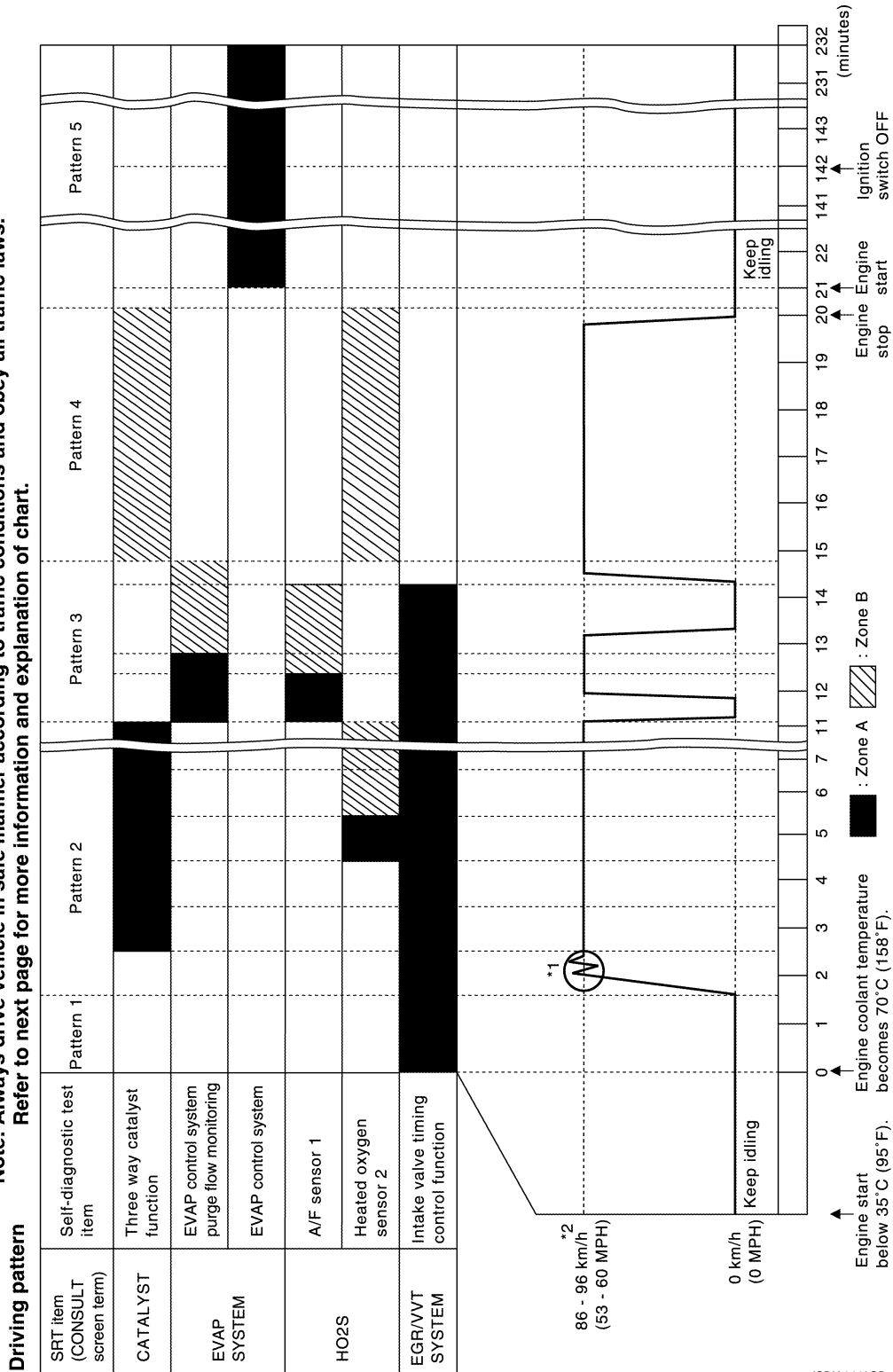

JSBIA1446GB

\*1: Depress the accelerator pedal until vehicle speed is 90 km/h (56 MPH), then release the accelerator pedal and keep it released for more than 10 seconds. Depress the accelerator pedal until vehicle speed is 90 km/h (56 MPH) again.

\*2: Checking the vehicle speed with GST is advised.

- The time required for each diagnosis varies with road surface conditions, weather, altitude, individual driving habits, etc.

Zone A refers to the range where the time, required for the diagnosis under normal conditions\*, is the shortest.

# HOW TO SET SRT CODE

[VK56VD FOR USA AND CANADA]

## < BASIC INSPECTION >

Zone B refers to the range where the diagnosis can still be performed if the diagnosis is not completed within zone A.

\*: Normal conditions refer to the following:

- Sea level
  - Flat road
  - Ambient air temperature: 20 - 30°C (68 - 86°F)
  - Diagnosis is performed as quickly as possible under normal conditions.
- Under different conditions [For example: ambient air temperature other than 20 - 30°C (68 - 86°F)], diagnosis may also be performed.

## Work Procedure

INFOID:000000007187444

### 1. CHECK DTC

Check DTC.

Is any DTC detected?

YES >> Repair malfunction(s) and erase DTC. Refer to [EC-1083, "DTC Index"](#).

NO >> GO TO 2.

### 2. CHECK SRT STATUS

WITH CONSULT

Select "SRT STATUS" in "DTC & SRT CONFIRMATION" mode with CONSULT.

WITHOUT CONSULT

Perform "SRT status" mode with [EC-1041, "On Board Diagnosis Function"](#).

WITH GST

Select Service \$01 with GST.

Is SRT code(s) set?

YES >> GO TO 11.

NO-1 >> With CONSULT: GO TO 3.

NO-2 >> Without CONSULT: GO TO 4.

### 3. DTC CONFIRMATION PROCEDURE

1. Select "SRT WORK SUPPORT" in "DTC & SRT CONFIRMATION" mode with CONSULT.
2. For SRT(s) that is not set, perform the corresponding "DTC CONFIRMATION PROCEDURE" according to the "Performance Priority" in the "SRT ITEM" table. Refer to [EC-1130, "Description"](#).
3. Check DTC.

Is any DTC detected?

YES >> Repair malfunction(s) and erase DTC. Refer to [EC-1083, "DTC Index"](#).

NO >> GO TO 10.

### 4. PERFORM ROAD TEST

- Check the "Performance Priority" in the "SRT ITEM" table. Refer to [EC-1130, "Description"](#).
- Perform the most efficient SRT set driving pattern to set the SRT properly. Refer to [EC-1131, "SRT Set Driving Pattern"](#).

In order to set all SRTs, the SRT set driving pattern must be performed at least once.

>> GO TO 5.

### 5. PATTERN 1

1. Check the vehicle condition;
  - Engine coolant temperature is -10 to 35°C (14 to 95°F).
  - Fuel tank temperature is more than 0°C (32°F).
2. Start the engine.
3. Keep engine idling until the engine coolant temperature is greater than 70°C (158°F)

#### NOTE:

ECM terminal voltage is follows;

- Engine coolant temperature
  - -10 to 35°C (14 to 95°F): 3.0 - 4.3 V
  - 70°(158°F): Less than 1.4 V

## HOW TO SET SRT CODE

[VK56VD FOR USA AND CANADA]

< BASIC INSPECTION >

- Fuel tank temperature: Less than 4.1 V  
Refer to [EC-1055, "Reference Value"](#).

>> GO TO 6.

### 6.PATTERN 2

1. Drive the vehicle. And depress the accelerator pedal until vehicle speed is 90 km/h (56 MPH), then release the accelerator pedal and keep it released for more than 10 seconds.
2. Depress the accelerator pedal until vehicle speed is 90 km/h (56 MPH) again

#### NOTE:

- Checking the vehicle speed with GST is advised.
- When steady-state driving is performed again even after it is interrupted, each diagnosis can be conducted. In this case, the time required for diagnosis may be extended.

>> GO TO 7.

### 7.PATTERN 3

- Operate vehicle following the driving pattern shown in the figure.
- Release the accelerator pedal during deceleration of vehicle speed from 90 km/h (56 MPH) to 0 km/h (0 MPH).

>> GO TO 8.

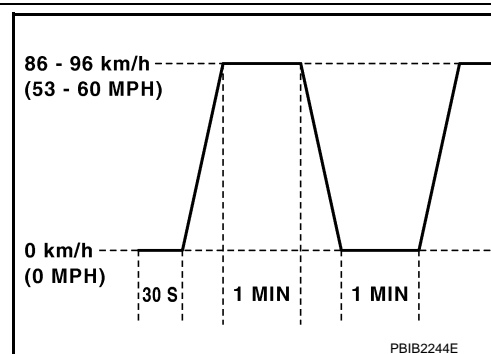

### 8.PATTERN 4

- The accelerator pedal must be held very steady during steady-state driving.
- If the accelerator pedal is moved, the test must be conducted again.

>> GO TO 9.

### 9.PATTERN 5

- Cool down the engine so that the engine coolant temperature lowers between 15 - 35°C (59 - 95°F).

#### CAUTION:

**Never turn the ignition switch ON while cooling down the engine.**

- Engine coolant temperature at engine start is between 15 - 35°C (59 - 95°F) and has lowered 45°C (113°F) or more since the latest engine stop.

>> GO TO 10.

### 10.CHECK SRT STATUS

#### Ⓟ WITH CONSULT

Select "SRT STATUS" in "DTC & SRT CONFIRMATION" mode with CONSULT.

#### ⓧ WITHOUT CONSULT

Perform "SRT status" mode with [EC-1041, "On Board Diagnosis Function"](#).

#### Ⓢ WITH GST

Select Service \$01 with GST.

Is SRT(s) set?

YES >> END

NO >> Call TECH LINE or take appropriate action.

### 11.CHECK PERMANENT DTC

#### NOTE:

Permanent DTC cannot be checked with a tool other than CONSULT or GST.

# HOW TO SET SRT CODE

[VK56VD FOR USA AND CANADA]

< BASIC INSPECTION >

Ⓜ With CONSULT

Select "SRT STATUS" in "DTC & SRT CONFIRMATION" mode with CONSULT.

Ⓜ With GST

Select Service \$0A with GST.

Is permanent DTC(s) detected?

YES >> Go to [EC-1136. "Description"](#).  
NO >> END

A

EC

C

D

E

F

G

H

I

J

K

L

M

N

O

P

# HOW TO ERASE PERMANENT DTC

< BASIC INSPECTION >

[VK56VD FOR USA AND CANADA]

## HOW TO ERASE PERMANENT DTC

### Description

INFOID:000000007195372

### OUTLINE

When a DTC is stored in ECM

When a DTC is stored in ECM and MIL is ON, a permanent DTC is erased with MIL shutoff if the same malfunction is not detected after performing the driving pattern for MIL shutoff three times in a row.

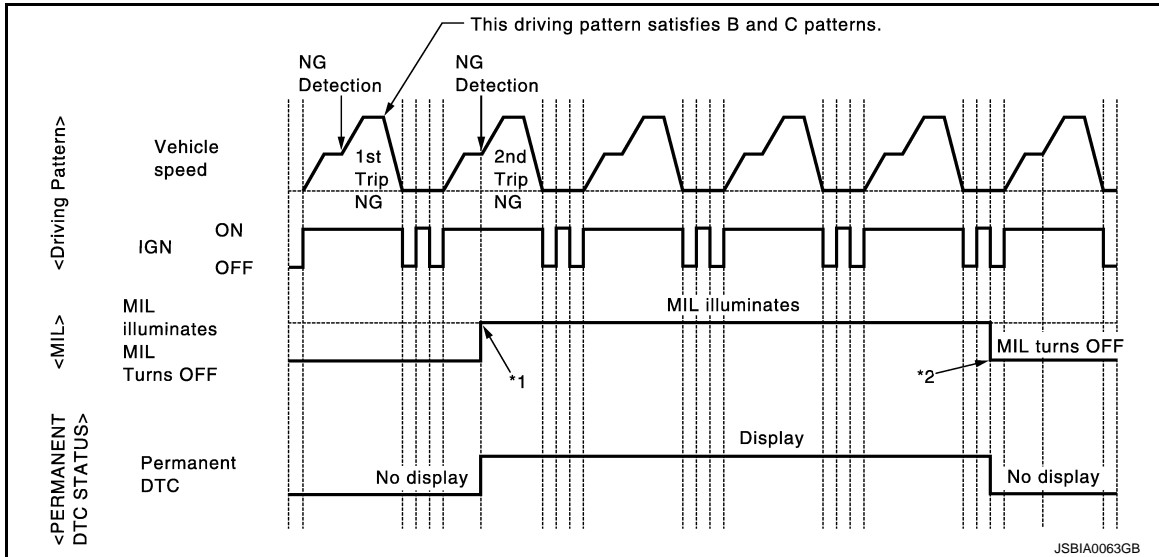

\*1: When the same malfunction is detected in two consecutive trips, MIL will illuminate.

\*2: MIL will turn off after vehicle is driven 3 times (driving pattern B) without any malfunctions.

When a DTC is not stored in ECM

The erasing method depends on a permanent DTC stored in ECM. Refer to the following table.

#### NOTE:

If the applicable permanent DTC includes multiple groups, perform the procedure of Group B first. If the permanent DTC is not erased, perform the procedure of Group A.

×: Applicable —: Not applicable

| Group * | Perform "DTC CONFIRMATION PROCEDURE" for applicable DTCs. | Driving pattern |   | Reference   |
|---------|---|-----------------|---|---|
|         |   | B               | D |   |
| A       | ×   | —               | — | <a href="#">EC-1137. "Work Procedure (Group A)"</a> |
| B       | —   | ×               | × | <a href="#">EC-1139. "Work Procedure (Group B)"</a> |

\*: For group, refer to [EC-1083. "DTC Index"](#).

#### PERMANENT DTC ITEM

For permanent DTC items, MIL turns ON. Refer to [EC-1083. "DTC Index"](#).



# HOW TO ERASE PERMANENT DTC

< BASIC INSPECTION >

[VK56VD FOR USA AND CANADA]

## PERMANENT DTC SERVICE PROCEDURE

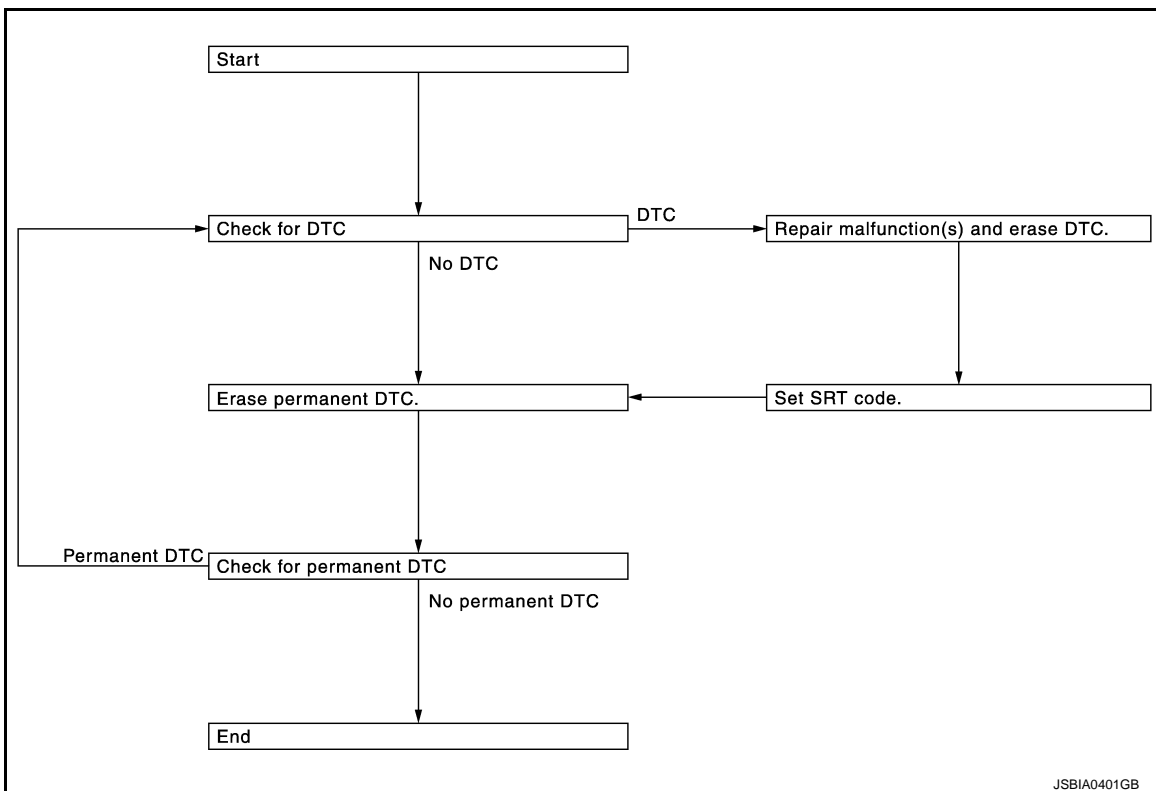

### Work Procedure (Group A)

INFOID:000000007195373

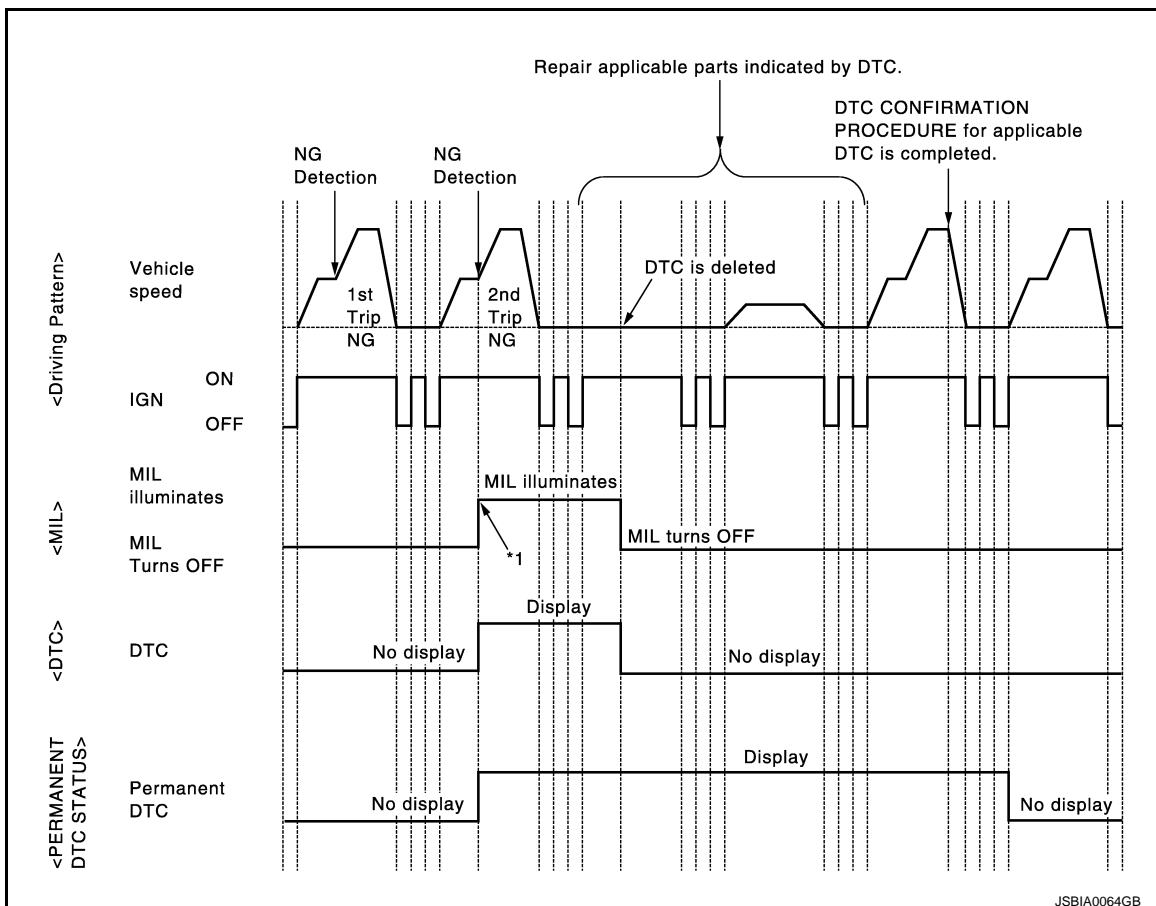

# HOW TO ERASE PERMANENT DTC

[VK56VD FOR USA AND CANADA]

< BASIC INSPECTION >

---

\*1: When the same malfunction is detected in two consecutive trips, MIL will illuminate.

## 1. CHECK DTC

---

Check DTC.

Is any DTC detected?

YES >> Repair malfunction(s) and erase DTC. Refer to [EC-1041, "On Board Diagnosis Function"](#), [EC-1044, "CONSULT Function"](#).

NO >> GO TO 2.

## 2. CHECK PERMANENT DTC

---

 With CONSULT

1. Turn ignition switch OFF and wait at least 10 seconds.
2. Turn ignition switch ON.
3. Turn ignition switch OFF and wait at least 10 seconds.
4. Turn ignition switch ON.
5. Select "PERMANENT DTC STATUS" mode with CONSULT.

 With GST

1. Turn ignition switch OFF and wait at least 10 seconds.
2. Turn ignition switch ON.
3. Turn ignition switch OFF and wait at least 10 seconds.
4. Turn ignition switch ON.
5. Select Service \$0A with GST.

Is any permanent DTC detected?

YES >> GO TO 3.

NO >> END

## 3. PERFORM DTC CONFIRMATION PROCEDURE

---

Perform "DTC CONFIRMATION PROCEDURE" for DTCs which are the same as permanent DTCs stored in ECM. Refer to [EC-1083, "DTC Index"](#).

>> GO TO 4.

## 4. CHECK PERMANENT DTC

---

 With CONSULT

1. Turn ignition switch OFF and wait at least 10 seconds.
2. Turn ignition switch ON.
3. Turn ignition switch OFF and wait at least 10 seconds.
4. Turn ignition switch ON.
5. Select "PERMANENT DTC STATUS" mode with CONSULT.

 With GST

1. Turn ignition switch OFF and wait at least 10 seconds.
2. Turn ignition switch ON.
3. Turn ignition switch OFF and wait at least 10 seconds.
4. Turn ignition switch ON.
5. Select Service \$0A with GST.

Is any permanent DTC detected?

YES >> GO TO 1.

NO >> END

# HOW TO ERASE PERMANENT DTC

< BASIC INSPECTION >

[VK56VD FOR USA AND CANADA]

## Work Procedure (Group B)

INFOID:000000007195374

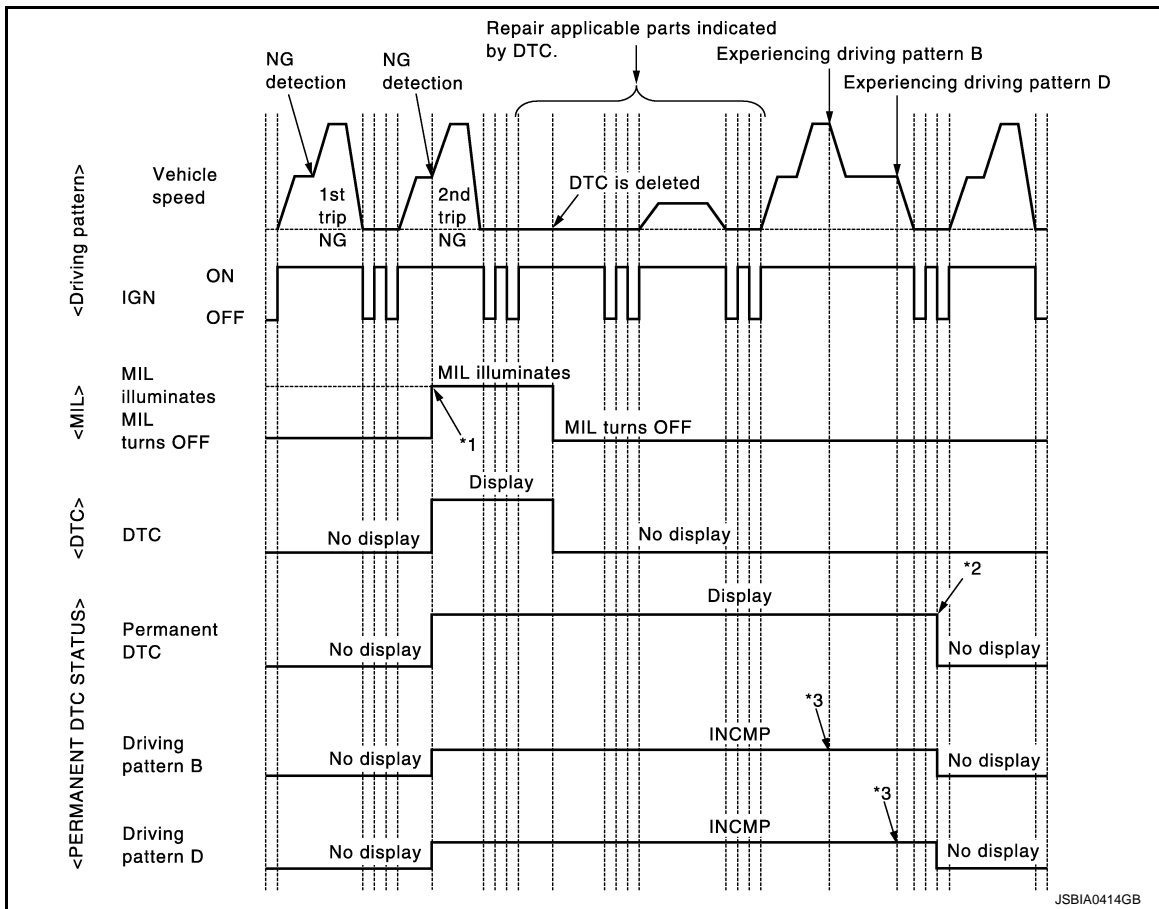

\*1: When the same malfunction is detected in two consecutive trips, MIL will illuminate.

\*2: After experiencing driving pattern B and D, permanent DTC is erased.

\*3: Indication does not change unless the ignition switch is turned from ON to OFF twice even after experiencing driving pattern B or D.

### NOTE:

Drive the vehicle according to only driving patterns indicating "INCMP" in driving patterns B and D on the "PERMANENT DTC STATUS" screen.

## 1. CHECK DTC

Check DTC.

Is any DTC detected?

YES >> Repair malfunction(s) and erase DTC. Refer to [EC-1041. "On Board Diagnosis Function"](#), [EC-1044. "CONSULT Function"](#).

NO >> GO TO 2.

## 2. CHECK PERMANENT DTC

With CONSULT

1. Turn ignition switch OFF and wait at least 10 seconds.
2. Turn ignition switch ON.
3. Turn ignition switch OFF and wait at least 10 seconds.
4. Turn ignition switch ON.
5. Select "PERMANENT DTC STATUS" mode with CONSULT.

With GST

1. Turn ignition switch OFF and wait at least 10 seconds.
2. Turn ignition switch ON.
3. Turn ignition switch OFF and wait at least 10 seconds.

# HOW TO ERASE PERMANENT DTC

[VK56VD FOR USA AND CANADA]

< BASIC INSPECTION >

4. Turn ignition switch ON.
5. Select Service \$0A with GST.

Is any permanent DTC detected?

- YES >> GO TO 3.  
NO >> END

## 3.DRIVE DRIVING PATTERN B

### CAUTION:

- Always drive at a safe speed.
- Never erase self-diagnosis results.
- If self-diagnosis results are erased during the trip of driving pattern B or D, the counter of driving pattern B and D is reset.

Ⓟ With CONSULT

1. Start engine and warm it up to normal operating temperature.
2. Use "PERMANENT DTC WORK SUPPORT" mode with CONSULT to drive the vehicle according to driving pattern B. Refer to [EC-1044, "CONSULT Function"](#), [EC-1038, "DIAGNOSIS DESCRIPTION : Driving Pattern"](#).

Ⓢ With GST

1. Start engine and warm it up to normal operating temperature.
2. Drive the vehicle according to driving pattern B. Refer to [EC-1038, "DIAGNOSIS DESCRIPTION : Driving Pattern"](#).

>> GO TO 4.

## 4.CHECK PERMANENT DTC

Ⓟ With CONSULT

1. Turn ignition switch OFF and wait at least 10 seconds.
2. Turn ignition switch ON.
3. Turn ignition switch OFF and wait at least 10 seconds.
4. Turn ignition switch ON.
5. Select "PERMANENT DTC STATUS" mode with CONSULT.

Ⓢ With GST

1. Turn ignition switch OFF and wait at least 10 seconds.
2. Turn ignition switch ON.
3. Turn ignition switch OFF and wait at least 10 seconds.
4. Turn ignition switch ON.
5. Select Service \$0A with GST.

Is any permanent DTC detected?

- YES >> GO TO 5.  
NO >> END

## 5.DRIVE DRIVING PATTERN D

### CAUTION:

- Always drive at a safe speed.
- Never erase self-diagnosis results.
- If self-diagnosis results are erased during the trip of driving pattern B or D, the counter of driving pattern B and D is reset.

1. Drive the vehicle according to driving pattern D. Refer to [EC-1038, "DIAGNOSIS DESCRIPTION : Driving Pattern"](#).

>> GO TO 6.

## 6.CHECK PERMANENT DTC

Ⓟ With CONSULT

1. Turn ignition switch OFF and wait at least 10 seconds.
2. Turn ignition switch ON.
3. Turn ignition switch OFF and wait at least 10 seconds.
4. Turn ignition switch ON.

# HOW TO ERASE PERMANENT DTC

[VK56VD FOR USA AND CANADA]

< BASIC INSPECTION >

5. Select "PERMANENT DTC STATUS" mode with CONSULT.

 With GST

1. Turn ignition switch OFF and wait at least 10 seconds.
2. Turn ignition switch ON.
3. Turn ignition switch OFF and wait at least 10 seconds.
4. Turn ignition switch ON.
5. Select Service \$0A with GST.

Is any permanent DTC detected?

YES >> GO TO 1.

NO >> END

A

EC

C

D

E

F

G

H

I

J

K

L

M

N

O

P

## DTC/CIRCUIT DIAGNOSIS

### TROUBLE DIAGNOSIS - SPECIFICATION VALUE

#### Description

INFOID:000000007187445

The specification (SP) value indicates the tolerance of the value that is displayed in "SPEC" in "DATA MONITOR" mode of CONSULT during normal operation of the Engine Control System. When the value in "SPEC" in "DATA MONITOR" mode is within the SP value, the Engine Control System is confirmed OK. When the value in "SPEC" in "DATA MONITOR" mode is NOT within the SP value, the Engine Control System may have one or more malfunctions.

The SP value is used to detect malfunctions that may affect the Engine Control System, but will not illuminate the MIL.

The SP value will be displayed for the following items:

- B/FUEL SCHDL (The fuel injection pulse width programmed into ECM prior to any learned on board correction)
- A/F ALPHA-B1/B2 (The mean value of air-fuel ratio feedback correction factor per cycle)
- MAS A/F SE-B1/B2 (The signal voltage of the mass air flow sensor)
- IDLE FUEL PRES MAX/MIN (the signal voltage of the fuel rail pressure sensor)

#### Component Function Check

INFOID:000000007187446

### 1. PRECONDITIONING

Check that all of the following conditions are satisfied.

#### TESTING CONDITION

- Vehicle driven distance: More than 5,000 km (3,107 miles)
- Barometric pressure: 98.3 - 104.3 kPa (0.983 - 1.043 bar, 1.003 - 1.064 kg/cm<sup>2</sup>, 14.25 - 15.12 psi)
- Atmospheric temperature: 20 - 30°C (68 - 86°F)
- Engine coolant temperature: 75 - 95°C (167 - 203°F)
- Transmission: Warmed-up
- After the engine is warmed up to normal operating temperature, drive vehicle until "ATF TEMP 2" (A/T fluid temperature sensor signal) indicates more than 60°C (140°F).
- Electrical load: Not applied
- Rear window defogger switch, air conditioner switch and lighting switch are OFF. Steering wheel is straight ahead.
- Engine speed: Idle
- Gear position: Neutral ( or parking)

>> GO TO 2.

### 2. PERFORM SPEC IN DATA MONITOR MODE

#### Ⓟ WITH CONSULT

#### NOTE:

Perform "SPEC" in "DATA MONITOR" mode in maximum scale display.

1. Perform basic inspection. Refer to [EC-1113. "Work Procedure"](#).
2. Select "B/FUEL SCHDL", "A/F ALPHA-B1", "A/F ALPHA-B2", "MAS A/F SE-B1" and "MAS A/F SE-B2" in "SPEC" of "DATA MONITOR" mode with CONSULT.
3. Check that monitor items are within the SP value.

Is the measurement value within the SP value?

YES >> INSPECTION END

NO >> Proceed to [EC-1143. "Diagnosis Procedure"](#).

# TROUBLE DIAGNOSIS - SPECIFICATION VALUE

< DTC/CIRCUIT DIAGNOSIS >

[VK56VD FOR USA AND CANADA]

## Diagnosis Procedure

INFOID:000000007187447

### OVERALL SEQUENCE

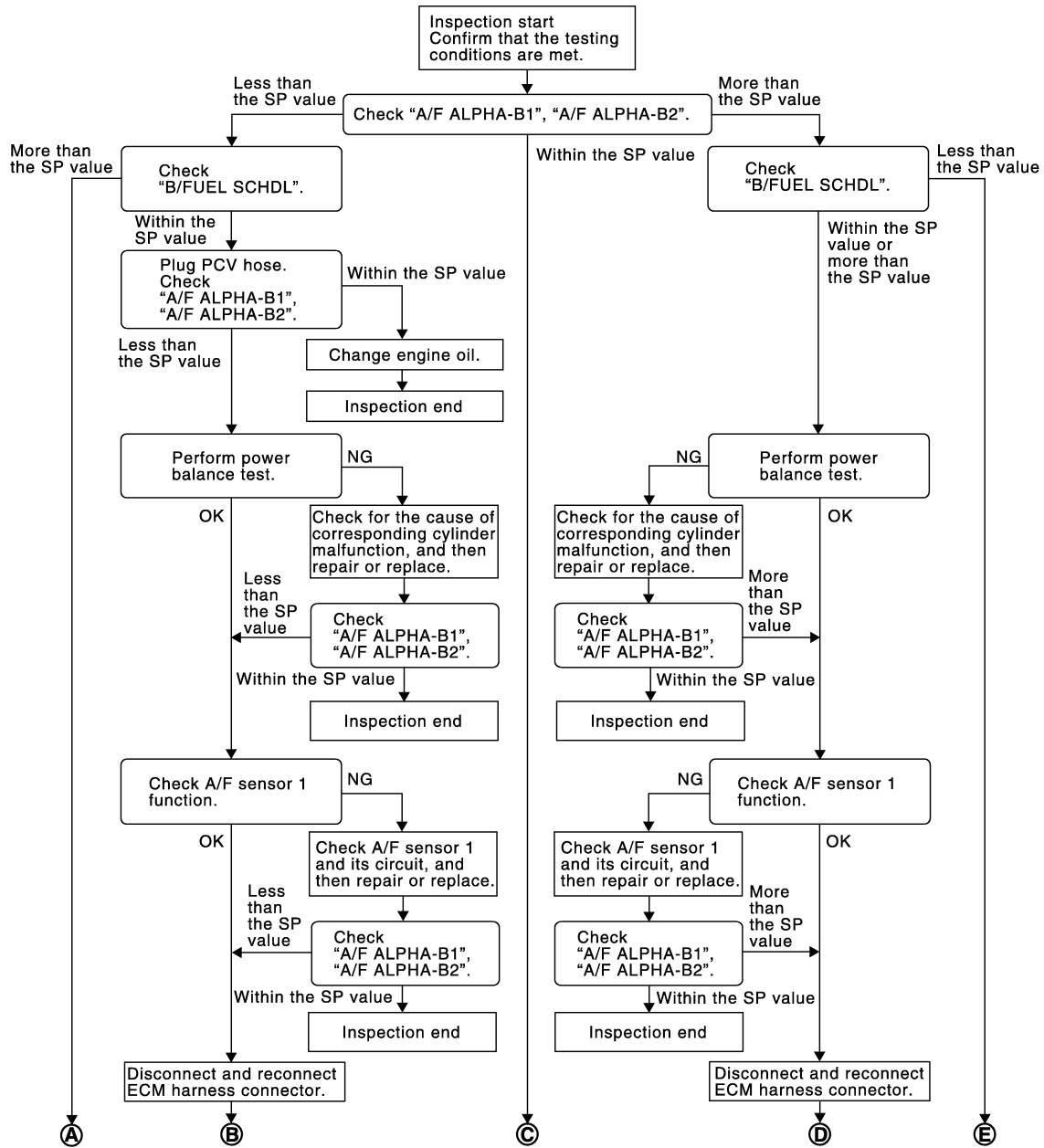

JSBIA0519GB

# TROUBLE DIAGNOSIS - SPECIFICATION VALUE

< DTC/CIRCUIT DIAGNOSIS >

[VK56VD FOR USA AND CANADA]

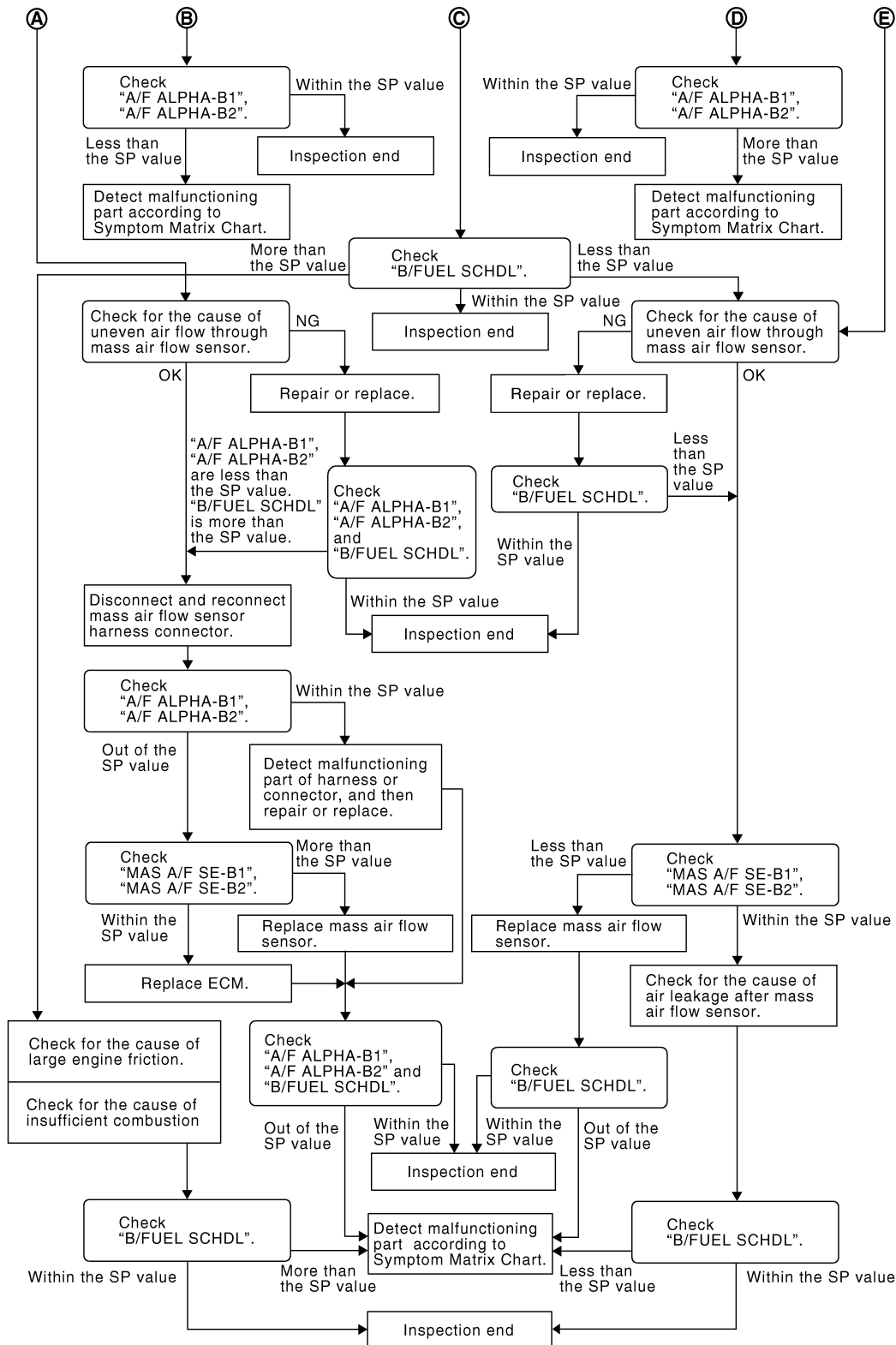

JMBIA0056GB

## DETAILED PROCEDURE

### 1. CHECK "A/F ALPHA-B1" AND "A/F ALPHA-B2"

#### ⓑ WITH CONSULT

1. Start engine.
2. Check that the testing conditions are met. Refer to [EC-1142, "Component Function Check"](#).
3. Select "A/F ALPHA-B1" and "A/F ALPHA-B2" in "SPEC" of "DATA MONITOR" mode, and check that each indication is within the SP value.



# TROUBLE DIAGNOSIS - SPECIFICATION VALUE

< DTC/CIRCUIT DIAGNOSIS >

[VK56VD FOR USA AND CANADA]

## NOTE:

Check "A/F ALPHA-B1" and "A/F ALPHA-B2" for approximately 1 minute because they may fluctuate. It is NG if the indication is out of the SP value even a little.

Is the measurement value within the SP value?

YES >> GO TO 14.

NO-1 >> Less than the SP value: GO TO 2.

NO-2 >> More than the SP value: GO TO 3.

## 2.CHECK "B/FUEL SCHDL"

Select "B/FUEL SCHDL" in "SPEC" of "DATA MONITOR" mode, and check that the indication is within the SP value.

Is the measurement value within the SP value?

YES >> GO TO 4.

NO >> More than the SP value: GO TO 16.

## 3.CHECK "B/FUEL SCHDL"

Select "B/FUEL SCHDL" in "SPEC" of "DATA MONITOR" mode, and check that the indication is within the SP value.

Is the measurement value within the SP value?

YES >> GO TO 6.

NO-1 >> More than the SP value: GO TO 6.

NO-2 >> Less than the SP value: GO TO 22.

## 4.CHECK "A/F ALPHA-B1", "A/F ALPHA-B2"

1. Stop the engine.

2. Disconnect PCV hose, and then plug it.

3. Start engine.

4. Select "A/F ALPHA-B1" and "A/F ALPHA-B2" in "SPEC" of "DATA MONITOR" mode, and check that each indication is within the SP value.

Is the measurement value within the SP value?

YES >> GO TO 5.

NO >> GO TO 6.

## 5.CHANGE ENGINE OIL

1. Stop the engine.

2. Change engine oil.

## NOTE:

This symptom may occur when a large amount of gasoline is mixed with engine oil because of driving conditions (such as when engine oil temperature does not rise enough since a journey distance is too short during winter). The symptom will not be detected after changing engine oil or changing driving conditions.

>> INSPECTION END

## 6.PERFORM POWER BALANCE TEST

1. Perform "POWER BALANCE" in "ACTIVE TEST" mode.

2. Check that each cylinder produces a momentary engine speed drop.

Is the inspection result normal?

YES >> GO TO 9.

NO >> GO TO 7.

## 7.DETECT MALFUNCTIONING PART

Check the following below.

- Ignition coil and its circuit (Refer to [EC-1525, "Component Function Check".](#))
- Fuel injector and its circuit (Refer to [EC-1517, "Component Function Check".](#))
- Intake air leakage
- Low compression pressure (Refer to [EM-172, "Inspection".](#))

Is the inspection result normal?

## TROUBLE DIAGNOSIS - SPECIFICATION VALUE

< DTC/CIRCUIT DIAGNOSIS >

[VK56VD FOR USA AND CANADA]

- YES >> Replace fuel injector. Refer to [EM-197, "Removal and Installation"](#). And then GO TO 8.  
NO >> Repair or replace malfunctioning part and then GO TO 8.

### 8.CHECK "A/F ALPHA-B1" AND "A/F ALPHA-B2"

1. Start engine.
2. Select "A/F ALPHA-B1" and "A/F ALPHA-B2" in "SPEC" of "DATA MONITOR" mode, and check that each indication is within the SP value.

Is the measurement value within the SP value?

- YES >> INSPECTION END  
NO >> GO TO 9.

### 9.CHECK A/F SENSOR 1 FUNCTION

Perform all DTC CONFIRMATION PROCEDURE related with A/F sensor 1.

- For DTC P0130, P0150, refer to [EC-1229, "DTC Logic"](#).
- For DTC P0131, P0151, refer to [EC-1233, "DTC Logic"](#).
- For DTC P0132, P0152, refer to [EC-1236, "DTC Logic"](#).
- For DTC P0133, P0153, refer to [EC-1239, "DTC Logic"](#).
- For DTC P2A00, P2A03, refer to [EC-1503, "DTC Logic"](#).

Are any DTCs detected?

- YES >> GO TO 10.  
NO >> GO TO 12.

### 10.CHECK A/F SENSOR 1 CIRCUIT

Perform Diagnosis Procedure according to corresponding DTC.

>> GO TO 11.

### 11.CHECK "A/F ALPHA-B1" AND "A/F ALPHA-B2"

1. Start engine.
2. Select "A/F ALPHA-B1" and "A/F ALPHA-B2" in "SPEC" of "DATA MONITOR" mode, and check that each indication is within the SP value.

Is the measurement value within the SP value?

- YES >> INSPECTION END  
NO >> GO TO 12.

### 12.DISCONNECT AND RECONNECT ECM HARNESS CONNECTOR

1. Stop the engine.
2. Disconnect ECM harness connector. Check pin terminal and connector for damage, and then reconnect it.

>> GO TO 13.

### 13.CHECK "A/F ALPHA-B1" AND "A/F ALPHA-B2"

1. Start engine.
2. Select "A/F ALPHA-B1" and "A/F ALPHA-B2" in "SPEC" of "DATA MONITOR" mode, and check that each indication is within the SP value.

Is the measurement value within the SP value?

- YES >> INSPECTION END  
NO >> Detect malfunctioning part according to [EC-1541, "Symptom Table"](#).

### 14.CHECK "B/FUEL SCHDL"

Select "B/FUEL SCHDL" in "SPEC" of "DATA MONITOR" mode, and check that the indication is within the SP value.

Is the measurement value within the SP value?

- YES >> INSPECTION END  
NO-1 >> More than the SP value: GO TO 15.  
NO-2 >> Less than the SP value: GO TO 22.

### 15.DETECT MALFUNCTIONING PART

# TROUBLE DIAGNOSIS - SPECIFICATION VALUE

[VK56VD FOR USA AND CANADA]

## < DTC/CIRCUIT DIAGNOSIS >

1. Check for the cause of large engine friction. Refer to the following.
  - Engine oil level is too high
  - Engine oil viscosity
  - Belt tension of power steering, alternator, A/C compressor, etc. is excessive
  - Noise from engine
  - Noise from transmission, etc.
2. Check for the cause of insufficient combustion. Refer to the following.
  - Valve clearance malfunction
  - Intake valve timing control function malfunction
  - Camshaft sprocket installation malfunction, etc.

>> Repair or replace malfunctioning part, and then GO TO 27.

## 16. CHECK INTAKE SYSTEM

Check for the cause of uneven air flow through mass air flow sensor. Refer to the following.

- Crushed air ducts
- Malfunctioning seal of air cleaner element
- Uneven dirt of air cleaner element
- Improper specification of intake air system

Is the inspection result normal?

YES >> GO TO 18.

NO >> Repair or replace malfunctioning part, and then GO TO 17.

## 17. CHECK "A/F ALPHA-B1", "A/F ALPHA-B2" AND "B/FUEL SCHDL"

Select "A/F ALPHA-B1", "A/F ALPHA-B2" and "B/FUEL SCHDL" in "SPEC" of "DATA MONITOR" mode, and check that each indication is within the SP value.

Is the measurement value within the SP value?

YES >> INSPECTION END

NO >> "B/FUEL SCHDL" is more, "A/F ALPHA-B1" and "A/F ALPHA-B2" are less than the SP value: GO TO 18.

## 18. DISCONNECT AND RECONNECT MASS AIR FLOW SENSOR HARNESS CONNECTOR

1. Stop the engine.
2. Disconnect mass air flow sensor harness connector. Check pin terminal and connector for damage and then reconnect it again.

>> GO TO 19.

## 19. CHECK "A/F ALPHA-B1" AND "A/F ALPHA-B2"

1. Start engine.
2. Select "A/F ALPHA-B1" and "A/F ALPHA-B2" in "SPEC" of "DATA MONITOR" mode, and check that each indication is within the SP value.

Is the measurement value within the SP value?

YES >> Detect malfunctioning part of mass air flow sensor circuit and repair it. Refer to [EC-1198. "DTC Logic"](#). Then GO TO 26.

NO >> GO TO 20.

## 20. CHECK "MAS A/F SE-B1" AND "MAS A/F SE-B2"

Select "MAS A/F SE-B1" and "MAS A/F SE-B2" in "SPEC" of "DATA MONITOR" mode, and check that the indication is within the SP value.

Is the measurement value within the SP value?

YES >> GO TO 21.

NO >> More than the SP value: Replace malfunctioning mass air flow sensor. Refer to [EM-184. "Removal and Installation"](#). And then GO TO 26.

## 21. REPLACE ECM

Replace ECM. Refer to [EC-1553. "Removal and Installation"](#)

A

EC

C

D

E

F

G

H

I

J

K

L

M

N

O

P

## TROUBLE DIAGNOSIS - SPECIFICATION VALUE

< DTC/CIRCUIT DIAGNOSIS >

[VK56VD FOR USA AND CANADA]

>> GO TO 26.

### 22.CHECK INTAKE SYSTEM

Check for the cause of uneven air flow through mass air flow sensor. Refer to the following.

- Crushed air ducts
- Malfunctioning seal in air cleaner element
- Uneven dirt in air cleaner element
- Improper specification in intake air system

Is the inspection result normal?

YES >> GO TO 24.

NO >> Repair or replace malfunctioning part, and then GO TO 23.

### 23.CHECK "B/FUEL SCHDL"

Select "B/FUEL SCHDL" in "SPEC" of "DATA MONITOR" mode, and check that the indication is within the SP value.

Is the measurement value within the SP value?

YES >> INSPECTION END

NO >> Less than the SP value: GO TO 24.

### 24.CHECK "MAS A/F SE-B1" AND "MAS A/F SE-B2"

Select "MAS A/F SE-B1" and "MAS A/F SE-B2" in "SPEC" of "DATA MONITOR" mode, and check that the indication is within the SP value.

Is the measurement value within the SP value?

YES >> GO TO 25.

NO >> Less than the SP value: Replace malfunctioning mass air flow sensor. Refer to [EM-184, "Removal and Installation"](#). And then GO TO 27.

### 25.CHECK INTAKE SYSTEM

Check for the cause of air leakage after the mass air flow sensor. Refer to the following.

- Disconnection, looseness, and cracks in air duct
- Looseness of oil filler cap
- Disconnection of oil level gauge
- Open stuck, breakage, hose disconnection, or cracks in PCV valve
- Disconnection or cracks in EVAP purge hose, stuck open EVAP canister purge volume control solenoid valve
- Malfunctioning seal in rocker cover gasket
- Disconnection, looseness, or cracks in hoses, such as a vacuum hose, connecting to intake air system parts
- Malfunctioning seal in intake air system, etc.

>> GO TO 27.

### 26.CHECK "A/F ALPHA-B1", "A/F ALPHA-B2" AND "B/FUEL SCHDL"

Select "A/F ALPHA-B1", "A/F ALPHA-B2" and "B/FUEL SCHDL" in "SPEC" of "DATA MONITOR" mode, and check that each indication is within the SP value.

Is the measurement value within the SP value?

YES >> INSPECTION END

NO >> Detect malfunctioning part according to [EC-1541, "Symptom Table"](#).

### 27.CHECK "B/FUEL SCHDL"

Select "B/FUEL SCHDL" in "SPEC" of "DATA MONITOR" mode, and then check that the indication is within the SP value.

Is the measurement value within the SP value?

YES >> INSPECTION END

NO >> Detect malfunctioning part according to [EC-1541, "Symptom Table"](#).

# POWER SUPPLY AND GROUND CIRCUIT

< DTC/CIRCUIT DIAGNOSIS >

[VK56VD FOR USA AND CANADA]

## POWER SUPPLY AND GROUND CIRCUIT

### Diagnosis Procedure

INFOID:000000007187448

#### 1.CHECK FUSE

Check that the following fuse is not fusing.

| Location | Fuse No. | Capacity |
|----------|----------|----------|
| IPDM E/R | #51      | 15A      |
|          | #42      | 10A      |

Is the fuse fusing?

YES >> Replace the fuse after repairing the applicable circuit.

NO >> GO TO 2.

#### 2.CHECK GROUND CONNECTION

1. Check ground connection M11, M95 and M95. Refer to [PG-49. "Main Harness"](#).

Is the inspection result normal?

YES >> GO TO 3.

NO >> Repair or replace ground connection.

#### 3.CHECK ECM GROUND CIRCUIT

1. Disconnect ECM harness connector.

2. Check the continuity between ECM harness connector and ground.

| ECM       |          | Ground | Continuity |
|-----------|----------|--------|------------|
| Connector | Terminal |        |            |
| F110      | 5        | Ground | Existed    |
|           | 10       |        |            |
| M160      | 114      |        |            |
|           | 115      |        |            |
|           | 174      |        |            |
|           | 175      |        |            |

3. Also check harness for short to power.

Is the inspection result normal?

YES >> GO TO 4.

NO >> Repair open circuit in harness or connectors.

#### 4.CHECK ECM POWER SUPPLY (MAIN)-1

1. Reconnect ECM harness connector.

2. Turn ignition switch ON.

3. Check the voltage between ECM harness connector and ground.

| ECM       |          |           |          | Voltage<br>(Approx.) |
|-----------|----------|-----------|----------|----------------------|
| +         |          | -         |          |                      |
| Connector | Terminal | Connector | Terminal |                      |
| M160      | 171      | M160      | 175      | Battery voltage      |
|           | 172      |           |          |                      |

Is the inspection result normal?

YES >> GO TO 6.

NO >> GO TO 5.

#### 5.CHECK ECM POWER SUPPLY (MAIN) CIRCUIT

# POWER SUPPLY AND GROUND CIRCUIT

< DTC/CIRCUIT DIAGNOSIS >

[VK56VD FOR USA AND CANADA]

1. Turn ignition switch OFF.
2. Disconnect ECM harness connector and IPDM E/R harness connector.
3. Check the continuity between ECM harness connector and IPDM E/R harness connector.

| ECM       |          | IPDM E/R  |          | Continuity |
|-----------|----------|-----------|----------|------------|
| Connector | Terminal | Connector | Terminal |            |
| M160      | 171      | E5        | 6        | Existed    |
|           | 172      |           |          |            |

Is the inspection result normal?

YES >> Replace IPDM E/R. Refer to [PCS-33. "Removal and Installation"](#).

NO >> Repair harness or connectors.

## 6. CHECK ECM POWER SUPPLY (MAIN)-2

1. Turn ignition switch OFF and wait at least 10 seconds.
2. Check the voltage between ECM harness connector terminals as per the following.

| ECM       |          |           |          | Condition   | Voltage (Approx.) |
|-----------|----------|-----------|----------|---|-------------------|
| +         |          | -         |          |   |                   |
| Connector | Terminal | Connector | Terminal |   |                   |
| M160      | 171      | M160      | 175      | After turning ignition switch OFF, battery voltage will exist for a few seconds | Drop to 0 V.      |
|           | 172      |           |          |   |                   |

Is the inspection result normal?

YES >> GO TO 9.

NO >> GO TO 7.

## 7. CHECK ECM RELAY CONTROL SIGNAL

1. Check the voltage between ECM harness connector terminals as per the following.

| ECM       |          |           |          | Condition  | Voltage (Approx.) |
|-----------|----------|-----------|----------|--|-------------------|
| +         |          | -         |          |  |                   |
| Connector | Terminal | Connector | Terminal |  |                   |
| M160      | 163      | M160      | 175      | Ignition switch ON                                     | 0 V               |
|           |          |           |          | Turn ignition switch OFF and wait at least 10 seconds. | Battery voltage   |

Is the inspection result normal?

YES >> Check intermittent incident. Refer to [GI-44. "Intermittent Incident"](#).

NO >> GO TO 8.

## 8. CHECK ECM RELAY CONTROL CIRCUIT

1. Disconnect ECM harness connector.
2. Disconnect IPDM E/R harness connector.
3. Check the continuity between ECM harness connector and IPDM E/R harness connector.

| ECM       |          | IPDM E/R  |          | Continuity |
|-----------|----------|-----------|----------|------------|
| Connector | Terminal | Connector | Terminal |            |
| M160      | 163      | E7        | 70       | Existed    |

4. Also check harness for short to ground and short to power.

Is the inspection result normal?

YES >> Replace IPDM E/R. Refer to [PCS-33. "Removal and Installation"](#).

NO >> Repair harness or connectors.

# POWER SUPPLY AND GROUND CIRCUIT

< DTC/CIRCUIT DIAGNOSIS >

[VK56VD FOR USA AND CANADA]

## 9. CHECK IGNITION SWITCH SIGNAL

1. Reconnect ECM harness connector.
2. Turn ignition switch ON.
3. Check the voltage between ECM harness connector terminals.

| ECM       |          |           |          | Condition           | Voltage (Approx.) |
|-----------|----------|-----------|----------|---------------------|-------------------|
| +         |          | -         |          |                     |                   |
| Connector | Terminal | Connector | Terminal |                     |                   |
| M160      | 141      | M160      | 175      | Ignition switch OFF | 0 V               |
|           |          |           |          | Ignition switch ON  | Battery voltage   |

Is the inspection result normal?

YES >> GO TO 11.

NO >> GO TO 10.

## 10. CHECK IGNITION SWITCH SIGNAL CIRCUIT

1. Disconnect ECM harness connector.
2. Disconnect IPDM E/R harness connector.
3. Check the continuity between ECM harness connector and IPDM E/R harness connector.

| ECM       |          | IPDM E/R  |          | Continuity |
|-----------|----------|-----------|----------|------------|
| Connector | Terminal | Connector | Terminal |            |
| M160      | 141      | E7        | 52       | Existed    |

4. Also check harness for short to ground and short to power.

Is the inspection result normal?

YES >> Replace IPDM E/R. Refer to [PCS-33, "Removal and Installation"](#).

NO >> Repair harness or connectors.

## 11. CHECK ECM POWER SUPPLY (BACK-UP)

1. Reconnect ECM harness connector.
2. Turn ignition switch OFF.
3. Check the voltage between ECM harness connector terminals.

| ECM       |          |           |          | Voltage (Approx.) |
|-----------|----------|-----------|----------|-------------------|
| +         |          | -         |          |                   |
| Connector | Terminal | Connector | Terminal |                   |
| M160      | 156      | M160      | 175      | Battery voltage   |

Is the inspection result normal?

YES >> INSPECTION END

NO >> GO TO 12.

## 12. CHECK ECM POWER SUPPLY (BACK-UP) CIRCUIT

1. Disconnect ECM harness connector.
2. Disconnect IPDM E/R harness connector.
3. Check the continuity between ECM harness connector and IPDM E/R harness connector.

| ECM       |          | IPDM E/R  |          | Continuity |
|-----------|----------|-----------|----------|------------|
| Connector | Terminal | Connector | Terminal |            |
| M160      | 156      | E5        | 10       | Existed    |

4. Also check harness for short to ground and short to power.

Is the inspection result normal?

YES >> Replace IPDM E/R. Refer to [PCS-33, "Removal and Installation"](#).

## POWER SUPPLY AND GROUND CIRCUIT

< DTC/CIRCUIT DIAGNOSIS >

[VK56VD FOR USA AND CANADA]

---

NO >> Repair harness or connectors.



# U0101 CAN COMM CIRCUIT

< DTC/CIRCUIT DIAGNOSIS >

[VK56VD FOR USA AND CANADA]

## U0101 CAN COMM CIRCUIT

### DTC Logic

INFOID:000000007187449

### DTC DETECTION LOGIC

| DTC No. | Trouble diagnosis name<br>(Trouble diagnosis content) | DTC detecting condition  | Possible cause   |
|---------|---|--|--|
| U0101   | LOST COMM (TCM)<br>(Lost communication with TCM)      | When ECM is not transmitting or receiving CAN communication signal of OBD (emission related diagnosis) with TCM for 2 seconds or more. | <ul style="list-style-type: none"><li>CAN communication line between TCM and ECM (CAN communication line is open or shorted)</li></ul> |

### DTC CONFIRMATION PROCEDURE

#### 1. PERFORM DTC CONFIRMATION PROCEDURE

1. Turn ignition switch ON and wait at least 3 seconds.
2. Check DTC.

#### Is DTC detected?

- YES >> Proceed to [EC-1153, "Diagnosis Procedure"](#).  
NO >> INSPECTION END

### Diagnosis Procedure

INFOID:000000007187450

Perform the trouble diagnosis for CAN communication system. Refer to [LAN-25, "Trouble Diagnosis Flow Chart"](#).

# U0113, U1003 CAN COMM CIRCUIT

< DTC/CIRCUIT DIAGNOSIS >

[VK56VD FOR USA AND CANADA]

## U0113, U1003 CAN COMM CIRCUIT

### DTC Logic

INFOID:000000007187451

### DTC DETECTION LOGIC

#### NOTE:

If DTC U0113 or U1003 is displayed with DTC P0607, first perform the trouble diagnosis for DTC P0607. Refer to [EC-1386, "DTC Logic"](#).

| DTC No. | Trouble diagnosis name<br>(Trouble diagnosis content)             | DTC detecting condition  | Possible cause   |
|---------|---|--|--|
| U0113   | CAN COMM CIRCUIT<br>(Lost communication with VVEL control module) | When ECM is not transmitting or receiving CAN communication signal of OBD (emission related diagnosis) with VVEL control module for 2 seconds or more.         | <ul style="list-style-type: none"><li>• Harness or connectors (VVEL CAN communication line is open or shorted)</li><li>• ECM</li><li>• VVEL control module</li></ul> |
| U1003   |   | When ECM is not transmitting or receiving CAN communication signal other than OBD (emission related diagnosis) with VVEL control module for 2 seconds or more. |  |

### DTC CONFIRMATION PROCEDURE

#### 1. PRECONDITIONING

#### TESTING CONDITION:

Before performing the following procedure, confirm that battery voltage is 10 V or more at idle.

>> GO TO 2.

#### 2. PERFORM DTC CONFIRMATION PROCEDURE

1. Turn ignition switch ON and wait at least 3 seconds.
2. Check DTC.

#### Is DTC detected?

YES >> Proceed to [EC-1154, "Diagnosis Procedure"](#).  
NO >> INSPECTION END

### Diagnosis Procedure

INFOID:000000007187452

#### 1. CHECK VVEL CAN COMMUNICATION CIRCUIT

1. Turn ignition switch OFF.
2. Disconnect ECM harness connector.
3. Disconnect VVEL control module harness connector.
4. Check the continuity between ECM harness connector and VVEL control module harness connector.

| ECM       |          | VVEL control module |          | Continuity |
|-----------|----------|---------------------|----------|------------|
| Connector | Terminal | Connector           | Terminal |            |
| M160      | 161      | E15                 | 24       | Existed    |
|           | 166      |                     | 11       |            |

5. Also check harness for short to ground and short to power.

#### Is the inspection result normal?

YES >> GO TO 3.  
NO >> GO TO 2.

#### 2. DETECT MALFUNCTIONING PART

Check the following.

- Harness for open or short between ECM and VVEL control module
- Loose or poor connection for each connector and harness

# U0113, U1003 CAN COMM CIRCUIT

[VK56VD FOR USA AND CANADA]

< DTC/CIRCUIT DIAGNOSIS >

>> Repair open circuit, short to ground or short to power in harness or connectors.

## 3. CHECK INTERMITTENT INCIDENT

Refer to [GI-44, "Intermittent Incident"](#).

Is the inspection result normal?

YES >> GO TO 4.

NO >> Repair or replace.

## 4. REPLACE VVEL CONTROL MODULE

Replace VVEL control module. Refer to [EC-1554, "Removal and Installation"](#).

>> GO TO 5.

## 5. PERFORM DTC CONFIRMATION PROCEDURE

### Ⓜ WITH CONSULT

1. Reconnect all harness connectors disconnected.
2. Turn ignition switch ON.
3. Select "SELF DIAGNOSTIC RESULT" mode with CONSULT.
4. Touch "ERASE".
5. Perform DTC Confirmation Procedure.  
See [EC-1154, "DTC Logic"](#).

### Ⓜ WITH GST

1. Reconnect all harness connectors disconnected.
2. Turn ignition switch ON.
3. Select Service \$04 with GST.
4. Perform DTC Confirmation Procedure.  
See [EC-1154, "DTC Logic"](#).

Is the DTC U0113 or U1003 displayed again?

YES >> GO TO 6.

NO >> INSPECTION END

## 6. REPLACE ECM

Replace ECM. Refer to [EC-1553, "Removal and Installation"](#).

>> INSPECTION END

A

EC

C

D

E

F

G

H

I

J

K

L

M

N

O

P

# U1001 CAN COMM CIRCUIT

< DTC/CIRCUIT DIAGNOSIS >

[VK56VD FOR USA AND CANADA]

## U1001 CAN COMM CIRCUIT

### DTC Logic

INFOID:000000007187453

### DTC DETECTION LOGIC

| DTC No. | Trouble diagnosis name<br>(Trouble diagnosis content) | DTC detecting condition   | Possible cause  |
|---------|---|---|---|
| U1001   | CAN COMM CIRCUIT<br>(CAN communication line)          | When ECM is not transmitting or receiving CAN communication signal other than OBD (emission related diagnosis) for 2 seconds or more. | <ul style="list-style-type: none"><li>Harness or connectors (CAN communication line is open or shorted)</li></ul> |

### DTC CONFIRMATION PROCEDURE

#### 1. PERFORM DTC CONFIRMATION PROCEDURE

- Turn ignition switch ON and wait at least 3 seconds.
- Check 1st trip DTC.

#### Is 1st trip DTC detected?

- YES >> Proceed to [EC-1156, "Diagnosis Procedure"](#).  
NO >> INSPECTION END

### Diagnosis Procedure

INFOID:000000007187454

Perform the trouble diagnosis for CAN communication system. Refer to [LAN-25, "Trouble Diagnosis Flow Chart"](#).

# U1024 CAN COMM CIRCUIT

< DTC/CIRCUIT DIAGNOSIS >

[VK56VD FOR USA AND CANADA]

## U1024 CAN COMM CIRCUIT

### DTC Logic

INFOID:000000007187455

### DTC DETECTION LOGIC

#### NOTE:

If DTC U1024 is displayed with DTC P0607, first perform the trouble diagnosis for DTC P0607.  
Refer to [EC-1386, "DTC Logic"](#).

| DTC No. | Trouble diagnosis name<br>(Trouble diagnosis content) | DTC detecting condition  | Possible cause  |
|---------|---|--|---|
| U1024   | VVEL CAN COMM CIRCUIT<br>(VVEL CAN communication)     | <ul style="list-style-type: none"><li>When VVEL control module cannot transmitting or receiving CAN communication signal with ECM for 2 seconds or more.</li><li>When detecting error during the initial diagnosis of CAN controller of VVEL control module.</li></ul> | <ul style="list-style-type: none"><li>Harness or connectors (CAN communication line is open or shorted)</li><li>ECM</li><li>VVEL control module</li></ul> |

### DTC CONFIRMATION PROCEDURE

#### 1. PRECONDITIONING

#### TESTING CONDITION:

Before performing the following procedure, confirm that battery voltage is 10 V or more at idle.

>> GO TO 2.

#### 2. PERFORM DTC CONFIRMATION PROCEDURE

- Turn ignition switch ON and wait at least 3 seconds.
- Check DTC.

#### Is DTC detected?

YES >> Proceed to [EC-1157, "Diagnosis Procedure"](#).  
NO >> INSPECTION END

### Diagnosis Procedure

INFOID:000000007187456

#### 1. CHECK VVEL CAN COMMUNICATION CIRCUIT

- Turn ignition switch OFF.
- Disconnect ECM harness connector.
- Disconnect VVEL control module harness connector.
- Check the continuity between ECM harness connector and VVEL control module harness connector.

| ECM       |          | VVEL control module |          | Continuity |
|-----------|----------|---------------------|----------|------------|
| Connector | Terminal | Connector           | Terminal |            |
| M160      | 161      | E15                 | 24       | Existed    |
|           | 166      |                     | 11       |            |

- Also check harness for short to ground and short to power.

#### Is the inspection result normal?

YES >> GO TO 3.  
NO >> GO TO 2.

#### 2. DETECT MALFUNCTIONING PART

Check the following.

- Harness for open or short between ECM and VVEL control module
- Loose or poor connection for each connector and harness

>> Repair open circuit, short to ground or short to power in harness or connectors.

# U1024 CAN COMM CIRCUIT

< DTC/CIRCUIT DIAGNOSIS >

[VK56VD FOR USA AND CANADA]

---

## 3. CHECK INTERMITTENT INCIDENT

---

Refer to [GI-44, "Intermittent Incident"](#).

Is the inspection result normal?

YES >> GO TO 4.

NO >> Repair or replace.

---

## 4. REPLACE VVEL CONTROL MODULE

---

Replace VVEL control module. Refer to [EC-1554, "Removal and Installation"](#).

>> GO TO 5.

---

## 5. PERFORM DTC CONFIRMATION PROCEDURE

---

 WITH CONSULT

1. Reconnect all harness connectors disconnected.
2. Turn ignition switch ON.
3. Select "SELF DIAGNOSTIC RESULT" mode with CONSULT.
4. Touch "ERASE".
5. Perform DTC Confirmation Procedure.  
See [EC-1157, "DTC Logic"](#).

 WITH GST

1. Reconnect all harness connectors disconnected.
2. Turn ignition switch ON.
3. Select Service \$04 with GST.
4. Perform DTC Confirmation Procedure.  
See [EC-1157, "DTC Logic"](#).

Is the DTC U1024 displayed again?

YES >> GO TO 6.

NO >> INSPECTION END

---

## 6. REPLACE ECM

---

Replace ECM. Refer to [EC-1553, "Removal and Installation"](#).

>> INSPECTION END

# P006A, P0101, P010B MAF SENSOR

< DTC/CIRCUIT DIAGNOSIS >

[VK56VD FOR USA AND CANADA]

## P006A, P0101, P010B MAF SENSOR

### DTC Logic

INFOID:000000007187457

### DTC DETECTION LOGIC

**NOTE:**

If DTC P006A, P0101 or P010B is displayed with other DTC, first perform the trouble diagnosis for other DTC.

| DTC No. | Trouble diagnosis name<br>(Trouble diagnosis content)                           | DTC detecting condition  | Possible cause  |
|---------|---|--|---|
| P006A   | MAP-MAF CORELTION-B1<br>(Manifold pressure - mass air flow correlation)         | A difference exceeding the specified value develops between a value transmitted from the manifold absolute pressure sensor to ECM and an estimated intake pressure of intake manifold calculated by ECM, based on a mass air flow sensor signal. | <ul style="list-style-type: none"> <li>• Harness or connectors (The sensor circuit is open or shorted.)</li> <li>• Mass air flow sensor</li> <li>• Manifold absolute pressure sensor</li> <li>• EVAP control system pressure sensor</li> <li>• Intake air leaks</li> <li>• Intake air temperature sensor</li> </ul> |
| P0101   | MAF SEN/CIRCUIT-B1<br>(Mass air flow sensor (bank 1) circuit range/performance) | A difference exceeding the specified value develops between a signal transmitted from the mass air flow sensor (bank 1) to ECM and a signal transmitted from the mass air flow sensor (bank 2) to ECM.   | Mass air flow sensor (bank 1)   |
| P010B   | MAF SEN/CIRCUIT-B2<br>(Mass air flow sensor (bank 2) circuit range/performance) |  | Mass air flow sensor (bank 2)   |

### DTC CONFIRMATION PROCEDURE

#### 1. PRECONDITIONING

1. Turn ignition switch OFF and wait at least 10 seconds.
  2. Turn ignition switch ON.
  3. Turn ignition switch OFF and wait at least 10 seconds.
- If engine will not start or stops soon, wait at least 10 seconds with engine stopped (Ignition switch ON) instead of running engine at idle speed.

>> GO TO 2.

#### 2. PERFORM DTC CONFIRMATION PROCEDURE

 WITH CONSULT

1. Turn ignition switch ON and select "DATA MONITOR" mode with CONSULT.
2. Start engine and warm it up to normal operating temperature.
3. Accelerate the vehicle from 0 km/h (0 MPH) to 88 km/h (55 MPH) under the following conditions:

**CAUTION:**

**Always drive at a safe speed.**

**NOTE:**

- Accelerate with the accelerator pedal kept constant.
- The acceleration at engine speed 2,000 and 3,000 rpm allows easy diagnoses

|                |             |
|----------------|-------------|
| ACCEL SEN 1    | 1.4 – 2.0 V |
| Selector lever | D position  |

4. Check 1st trip DTC.

 WITHOUT CONSULT

1. Start engine and warm it up to normal operating temperature.
2. With selector lever in D position, accelerate the vehicle from 0 km/h (0 MPH) to 88 km/h (55 MPH) under the following conditions:

**NOTE:**

# P006A, P0101, P010B MAF SENSOR

[VK56VD FOR USA AND CANADA]

## < DTC/CIRCUIT DIAGNOSIS >

- Accelerate with the accelerator pedal kept constant.
- The acceleration at engine speed 2,000 and 3,000 rpm allows easy diagnoses.

| Accelerator pedal position sensor 1 |          | Ground | Voltage (V) |
|-------------------------------------|----------|--------|-------------|
| Connector                           | Terminal |        |             |
| M9 (Whthout ICC)                    | 3        | Ground | 1.4 – 2.0   |
| M153 (With ICC)                     | 4        |        |             |

### CAUTION:

**Always drive at a safe speed.**

3. Check 1st trip DTC.

Is 1st trip DTC detected?

YES >> Proceed to [EC-1160. "Diagnosis Procedure"](#).

NO >> INSPECTION END

## Diagnosis Procedure

INFOID:000000007187458

### 1.CHECK INTAKE SYSTEM

Check the following for connection.

- Air duct
- Vacuum hoses
- Intake air passage between air duct and intake manifold

Is the inspection result normal?

YES >> GO TO 2.

NO >> Reconnect the parts.

### 2.CHECK MASS AIR FLOW SENSOR POWER SUPPLY CIRCUIT

1. Disconnect mass air flow sensor harness connector.
2. Turn ignition switch ON.
3. Check the voltage between mass air flow sensor harness connector and ground.

| DTC          | Mass air flow sensor |           |          | Ground | Voltage         |
|--------------|----------------------|-----------|----------|--------|-----------------|
|              | Bank                 | Connector | Terminal |        |                 |
| P006A, P0101 | 1                    | F86       | 5        | Ground | Battery voltage |
| P006A, P010B | 2                    | F85       | 5        |        |                 |

Is the inspection result normal?

YES >> GO TO 4.

NO >> GO TO 3.

### 3.DETECT MALFUNCTIONING PART

Check the following.

- Harness for open or short between mass air flow sensor and ECM
- Harness for open or short between mass air flow sensor and IPDM E/R
- Loose or poor connection for each connector and harness

>> Repair open circuit, short to ground or short to power in harness or connectors.

### 4.CHECK MASS AIR FLOW SENSOR GROUND CIRCUIT FOR OPEN AND SHORT

1. Turn ignition switch OFF.
2. Disconnect ECM harness connector.
3. Check the continuity between mass air flow sensor harness connector and ECM harness connector.



# P006A, P0101, P010B MAF SENSOR

< DTC/CIRCUIT DIAGNOSIS >

[VK56VD FOR USA AND CANADA]

| DTC          | Mass air flow sensor |           |          | ECM       |          | Continuity |
|--------------|----------------------|-----------|----------|-----------|----------|------------|
|              | Bank                 | Connector | Terminal | Connector | Terminal |            |
| P006A, P0101 | 1                    | F86       | 4        | F110      | 25       | Existed    |
| P006A, P010B | 2                    | F85       | 4        |           | 30       |            |

4. Also check harness for short to ground and short to power.

Is the inspection result normal?

YES >> GO TO 5.

NO >> Repair open circuit, short to ground or short to power in harness or connectors.

## 5.CHECK MASS AIR FLOW SENSOR INPUT SIGNAL CIRCUIT FOR OPEN AND SHORT

1. Check the continuity between mass air flow sensor harness connector and ECM harness connector.

| DTC          | Mass air flow sensor |           |          | ECM       |          | Continuity |
|--------------|----------------------|-----------|----------|-----------|----------|------------|
|              | Bank                 | Connector | Terminal | Connector | Terminal |            |
| P006A, P0101 | 1                    | F86       | 3        | F110      | 22       | Existed    |
| P006A, P010B | 2                    | F85       | 3        |           | 24       |            |

2. Also check harness for short to ground and short to power.

Is the inspection result normal?

YES >> GO TO 6.

NO >> Repair open circuit, short to ground or short to power in harness or connectors.

## 6.CHECK MANIFOLD ABSOLUTE PRESSURE SENSOR

Check manifold absolute pressure sensor. Refer to [EC-1206, "Component Inspection \(MAP Sensor\)"](#).

Is the inspection result normal?

YES >> GO TO 7.

NO >> Replace manifold absolute pressure sensor. Refer to [EM-190, "Exploded View"](#).

## 7.CHECK INTAKE AIR TEMPERATURE SENSOR

Check intake air temperature sensor. Refer to [EC-1226, "Component Inspection \(Intake Air Temperature Sensor\)"](#).

Is the inspection result normal?

YES >> GO TO 8.

NO >> Replace mass air flow sensor (with intake air temperature sensor). Refer to [EM-184, "Removal and Installation"](#).

## 8.CHECK EVAP CONTROL SYSTEM PRESSURE SENSOR

Refer to [EC-1343, "Component Inspection \(EVAP Control System Pressure Sensor\)"](#).

Is the inspection result normal?

YES-1 (Only DTC P006A is detected)>>GO TO 9.

YES-2 (DTC P006A and P0101 are detected)>>GO TO 10.

YES-3 (DTC P006A and P010B are detected)>>GO TO 11.

NO >> Replace EVAP control system pressure sensor. Refer to [FL-16, "Removal and Installation"](#)

## 9.CHECK MASS AIR FLOW SENSOR

Refer to [EC-1162, "Component Inspection \(MAF Sensor\)"](#).

Is the inspection result normal?

YES >> GO TO 12.

NO >> Replace mass air flow sensor (bank 1) and (bank 2). Refer to [EM-184, "Exploded View"](#).

## 10.CHECK MASS AIR FLOW SENSOR (BANK 1)

Check mass air flow sensor (bank 1). Refer to [EC-1162, "Component Inspection \(MAF Sensor\)"](#).

Is the inspection result normal?

YES >> GO TO 12.

# P006A, P0101, P010B MAF SENSOR

[VK56VD FOR USA AND CANADA]

< DTC/CIRCUIT DIAGNOSIS >

NO >> Replace mass air flow sensor (bank 1). Refer to [EM-184, "Removal and Installation"](#).

## 11. CHECK MASS AIR FLOW SENSOR (BANK 2)

Check mass air flow sensor (bank 2). Refer to [EC-1162, "Component Inspection \(MAF Sensor\)"](#).

Is the inspection result normal?

YES >> GO TO 12.

NO >> Replace mass air flow sensor (bank 2). Refer to [EM-184, "Removal and Installation"](#).

## 12. CHECK INTERMITTENT INCIDENT

Refer to [GI-44, "Intermittent Incident"](#).

>> INSPECTION END

## Component Inspection (MAF Sensor)

INFOID:000000007187459

### 1. CHECK MASS AIR FLOW SENSOR-I

#### WITH CONSULT

1. Turn ignition switch OFF.
2. Reconnect all harness connectors disconnected.
3. Start engine and warm it up to normal operating temperature.
4. Connect CONSULT and select "DATA MONITOR" mode.
5. Select "MAS A/F SE-B1" and "MAS A/F SE-B2", and check the indication.

| Monitor item                   | Condition  | Indication (V)              |
|--------------------------------|--|-----------------------------|
| MAS A/F SE-B1<br>MAS A/F SE-B2 | Ignition switch ON (Engine stopped.)                             | Approx. 0.4                 |
|                                | Idle (Engine is warmed-up to normal operating temperature.)      | 0.95 - 1.35                 |
|                                | 2,500 rpm (Engine is warmed-up to normal operating temperature.) | 1.3 - 1.7                   |
|                                | Idle to about 4,000 rpm  | 0.95 - 1.35 to Approx. 2.4* |

\*: Check for linear voltage rise in response to engine being increased to about 4,000 rpm.

#### WITHOUT CONSULT

1. Turn ignition switch OFF.
2. Reconnect all harness connectors disconnected.
3. Start engine and warm it up to normal operating temperature.
4. Check the voltage between ECM harness connector terminals under the following conditions.

| Connector | ECM                                   |          | Condition  | Voltage (V)                 |
|-----------|---------------------------------------|----------|--|-----------------------------|
|           | +                                     | -        |  |                             |
|           | Terminal                              | Terminal |  |                             |
| F110      | 22<br>[MAF sensor (bank 1)<br>signal] | 25       | Ignition switch ON (Engine stopped.)                             | Approx. 0.4                 |
|           |                                       |          | Idle (Engine is warmed-up to normal operating temperature.)      | 0.95 - 1.35                 |
|           |                                       |          | 2,500 rpm (Engine is warmed-up to normal operating temperature.) | 1.3 - 1.7                   |
|           |                                       |          | Idle to about 4,000 rpm  | 0.95 - 1.35 to Approx. 2.4* |
|           | 24<br>[MAF sensor (bank 2)<br>signal] | 30       | Ignition switch ON (Engine stopped.)                             | Approx. 0.4                 |
|           |                                       |          | Idle (Engine is warmed-up to normal operating temperature.)      | 0.95 - 1.35                 |
|           |                                       |          | 2,500 rpm (Engine is warmed-up to normal operating temperature.) | 1.3 - 1.7                   |
|           |                                       |          | Idle to about 4,000 rpm  | 0.95 - 1.35 to Approx. 2.4* |

\*: Check for linear voltage rise in response to engine being increased to about 4,000 rpm.

Is the inspection result normal?

YES >> INSPECTION END

# P006A, P0101, P010B MAF SENSOR

[VK56VD FOR USA AND CANADA]

## < DTC/CIRCUIT DIAGNOSIS >

NO >> GO TO 2.

### 2.CHECK FOR THE CAUSE OF UNEVEN AIR FLOW THROUGH MASS AIR FLOW SENSOR

1. Turn ignition switch OFF.
2. Check for the cause of uneven air flow through mass air flow sensor. Refer to the following.
  - Crushed air ducts
  - Malfunctioning seal of air cleaner element
  - Uneven dirt of air cleaner element
  - Improper specification of intake air system parts

Is the inspection result normal?

YES >> GO TO 4.

NO >> GO TO 3.

### 3.CHECK MASS AIR FLOW SENSOR-II

#### Ⓜ WITH CONSULT

1. Repair or replace malfunctioning part.
2. Start engine and warm it up to normal operating temperature.
3. Connect CONSULT and select "DATA MONITOR" mode.
4. Select "MAS A/F SE-B1" and "MAS A/F SE-B2", and check the indication.

| Monitor item                   | Condition  | Indication (V)              |
|--------------------------------|--|-----------------------------|
| MAS A/F SE-B1<br>MAS A/F SE-B2 | Ignition switch ON (Engine stopped.)                             | Approx. 0.4                 |
|                                | Idle (Engine is warmed-up to normal operating temperature.)      | 0.95 - 1.35                 |
|                                | 2,500 rpm (Engine is warmed-up to normal operating temperature.) | 1.3 - 1.7                   |
|                                | Idle to about 4,000 rpm  | 0.95 - 1.35 to Approx. 2.4* |

\*: Check for linear voltage rise in response to engine being increased to about 4,000 rpm.

#### ⓧ WITHOUT CONSULT

1. Repair or replace malfunctioning part.
2. Start engine and warm it up to normal operating temperature.
3. Check the voltage between ECM harness connector terminals under the following conditions.

| Connector | ECM                                   |          | Condition  | Voltage (V)                 |
|-----------|---------------------------------------|----------|--|-----------------------------|
|           | +                                     | -        |  |                             |
|           | Terminal                              | Terminal |  |                             |
| F110      | 22<br>[MAF sensor (bank 1)<br>signal] | 25       | Ignition switch ON (Engine stopped.)                             | Approx. 0.4                 |
|           |                                       |          | Idle (Engine is warmed-up to normal operating temperature.)      | 0.95 - 1.35                 |
|           |                                       |          | 2,500 rpm (Engine is warmed-up to normal operating temperature.) | 1.3 - 1.7                   |
|           |                                       |          | Idle to about 4,000 rpm  | 0.95 - 1.35 to Approx. 2.4* |
|           | 24<br>[MAF sensor (bank 2)<br>signal] | 30       | Ignition switch ON (Engine stopped.)                             | Approx. 0.4                 |
|           |                                       |          | Idle (Engine is warmed-up to normal operating temperature.)      | 0.95 - 1.35                 |
|           |                                       |          | 2,500 rpm (Engine is warmed-up to normal operating temperature.) | 1.3 - 1.7                   |
|           |                                       |          | Idle to about 4,000 rpm  | 0.95 - 1.35 to Approx. 2.4* |

\*: Check for linear voltage rise in response to engine being increased to about 4,000 rpm.

Is the inspection result normal?

YES >> INSPECTION END

NO >> GO TO 4.

### 4.CHECK MASS AIR FLOW SENSOR-III

#### Ⓜ WITH CONSULT

1. Turn ignition switch OFF.

# P006A, P0101, P010B MAF SENSOR

[VK56VD FOR USA AND CANADA]

## < DTC/CIRCUIT DIAGNOSIS >

2. Disconnect mass air flow sensor harness connector and reconnect it again.
3. Start engine and warm it up to normal operating temperature.
4. Connect CONSULT and select "DATA MONITOR" mode.
5. Select "MAS A/F SE-B1" and "MAS A/F SE-B2", and check the indication.

| Monitor item                   | Condition  | Indication (V)              |
|--------------------------------|--|-----------------------------|
| MAS A/F SE-B1<br>MAS A/F SE-B2 | Ignition switch ON (Engine stopped.)                             | Approx. 0.4                 |
|                                | Idle (Engine is warmed-up to normal operating temperature.)      | 0.95 - 1.35                 |
|                                | 2,500 rpm (Engine is warmed-up to normal operating temperature.) | 1.3 - 1.7                   |
|                                | Idle to about 4,000 rpm  | 0.95 - 1.35 to Approx. 2.4* |

\*: Check for linear voltage rise in response to engine being increased to about 4,000 rpm.

### ⊗ WITHOUT CONSULT

1. Turn ignition switch OFF.
2. Disconnect mass air flow sensor harness connector and reconnect it again.
3. Start engine and warm it up to normal operating temperature.
4. Check the voltage between ECM harness connector terminals under the following conditions.

| Connector | ECM                                   |          | Condition  | Voltage (V)                 |
|-----------|---------------------------------------|----------|--|-----------------------------|
|           | +                                     | -        |  |                             |
|           | Terminal                              | Terminal |  |                             |
| F110      | 22<br>[MAF sensor (bank 1)<br>signal] | 25       | Ignition switch ON (Engine stopped.)                             | Approx. 0.4                 |
|           |                                       |          | Idle (Engine is warmed-up to normal operating temperature.)      | 0.95 - 1.35                 |
|           |                                       |          | 2,500 rpm (Engine is warmed-up to normal operating temperature.) | 1.3 - 1.7                   |
|           |                                       |          | Idle to about 4,000 rpm  | 0.95 - 1.35 to Approx. 2.4* |
|           | 24<br>[MAF sensor (bank 2)<br>signal] | 30       | Ignition switch ON (Engine stopped.)                             | Approx. 0.4                 |
|           |                                       |          | Idle (Engine is warmed-up to normal operating temperature.)      | 0.95 - 1.35                 |
|           |                                       |          | 2,500 rpm (Engine is warmed-up to normal operating temperature.) | 1.3 - 1.7                   |
|           |                                       |          | Idle to about 4,000 rpm  | 0.95 - 1.35 to Approx. 2.4* |

\*: Check for linear voltage rise in response to engine being increased to about 4,000 rpm.

### Is the inspection result normal?

YES >> INSPECTION END

NO >> Clean or replace malfunctioning mass air flow sensor. Refer to [EM-184, "Removal and Installation"](#).

# P0011, P0021 IVT CONTROL

< DTC/CIRCUIT DIAGNOSIS >

[VK56VD FOR USA AND CANADA]

## P0011, P0021 IVT CONTROL

### DTC Logic

INFOID:000000007187460

### DTC DETECTION LOGIC

#### NOTE:

If DTC P0011 or P0021 is displayed with DTC P0075 or P0081, first perform the trouble diagnosis for DTC P0075, P0081. Refer to [EC-1179, "DTC Logic"](#).

| DTC No. | Trouble diagnosis<br>(Trouble diagnosis content)                        | Detecting condition  | Possible cause   |
|---------|---|--|--|
| P0011   | INT/V TIM CONT-B1<br>[Intake valve timing control performance (bank 1)] | There is a gap between angle of target and phase-control angle degree. | <ul style="list-style-type: none"> <li>• Crankshaft position sensor</li> <li>• Camshaft position sensor</li> <li>• Intake valve timing control solenoid valve</li> <li>• Accumulation of debris to the signal pick-up portion of the camshaft</li> <li>• Timing chain installation</li> <li>• Foreign matter caught in the oil groove for intake valve timing control</li> </ul> |
| P0021   | INT/V TIM CONT-B2<br>[Intake valve timing control performance (bank 2)] |  |  |

### DTC CONFIRMATION PROCEDURE

#### 1. PRECONDITIONING

1. Turn ignition switch OFF and wait at least 10 seconds.
2. Turn ignition switch ON.
3. Turn ignition switch OFF and wait at least 10 seconds.

#### TESTING CONDITION:

Before performing the following procedure, confirm that battery voltage is 10 V or more at idle.

>> GO TO 2.

#### 2. PERFORM DTC CONFIRMATION PROCEDURE-I

##### Ⓜ WITH CONSULT

1. Turn ignition switch ON and select "DATA MONITOR" mode with CONSULT.
2. Start engine and warm it up to the normal operating temperature.
3. Maintain the following conditions for at least 6 consecutive seconds.  
Hold the accelerator pedal as steady as possible.

|                |  |
|----------------|--|
| ENG SPEED      | Less than 2,000 rpm (A constant rotation is maintained.) |
| COOLAN TEMP/S  | More than 60°C (140°F)                                   |
| Selector lever | P or N position  |

4. Let engine idle for 25 seconds.
5. Check 1st trip DTC.

##### Ⓜ WITH GST

Follow the procedure "With CONSULT" above.

#### Is 1st trip DTC detected?

YES >> Proceed to [EC-1166, "Diagnosis Procedure"](#)

NO >> GO TO 3.

#### 3. PERFORM DTC CONFIRMATION PROCEDURE-II

##### Ⓜ WITH CONSULT

1. Select "DATA MONITOR" mode with CONSULT.
2. Maintain the following conditions for at least 20 consecutive seconds.

|               |  |
|---------------|--|
| ENG SPEED     | 1,300 - 3,175 rpm (A constant rotation is maintained.) |
| COOLAN TEMP/S | More than 60°C (140°F)                                 |

# P0011, P0021 IVT CONTROL

[VK56VD FOR USA AND CANADA]

< DTC/CIRCUIT DIAGNOSIS >

|                         |   |
|-------------------------|---|
| Selector lever          | 1st or 2nd position   |
| Driving location uphill | Driving vehicle uphill<br>(Increased engine load will help maintain the driving conditions required for this test.) |

## CAUTION:

**Always drive at a safe speed.**

3. Check 1st trip DTC.

 WITH GST

Follow the procedure "With CONSULT" above.

Is 1st trip DTC detected?

- YES >> Proceed to [EC-1166, "Diagnosis Procedure"](#).
- NO >> INSPECTION END

## Diagnosis Procedure

INFOID:000000007187461

### 1. CHECK OIL PRESSURE WARNING LAMP

1. Start engine.
2. Check that oil pressure warning lamp is not illuminated.

Is oil pressure warning lamp illuminated?

- YES >> Refer to [LU-23, "Inspection"](#).
- NO >> GO TO 2.

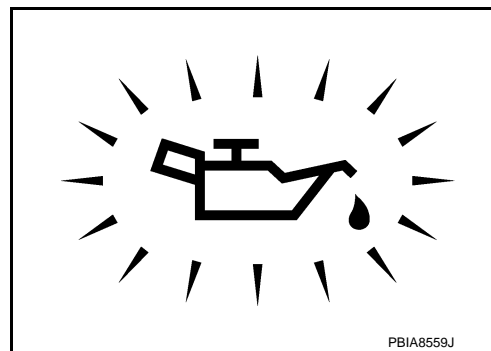

PBIA8559J

### 2. CHECK INTAKE VALVE TIMING CONTROL SOLENOID VALVE

Refer to [EC-1167, "Component Inspection \(Intake Valve Timing Control Solenoid Valve\)"](#).

Is the inspection result normal?

- YES >> GO TO 3.
- NO >> Replace malfunctioning intake valve timing control solenoid valve. Refer to [EM-231, "Exploded View"](#).

### 3. CHECK CRANKSHAFT POSITION SENSOR

Refer to [EC-1307, "Component Inspection \(Crankshaft Position Sensor\)"](#).

Is the inspection result normal?

- YES >> GO TO 4.
- NO >> Replace crankshaft position sensor. Refer to [EM-226, "Exploded View"](#) (2WD) or [EM-204, "2WD : Exploded View"](#) (AWD).

### 4. CHECK CAMSHAFT POSITION SENSOR

Refer to [EC-1312, "Component Inspection \(Camshaft Position Sensor\)"](#).

Is the inspection result normal?

- YES >> GO TO 5.
- NO >> Replace malfunctioning camshaft position sensor. Refer to [EM-231, "Exploded View"](#).

### 5. CHECK CAMSHAFT (INTAKE)

Check the following.

# P0011, P0021 IVT CONTROL

[VK56VD FOR USA AND CANADA]

## < DTC/CIRCUIT DIAGNOSIS >

- Accumulation of debris on the signal plate of camshaft front end
- Chipping signal plate of camshaft front end

Is the inspection result normal?

YES >> GO TO 6.

NO >> Remove debris and clean the signal plate of camshaft front end or replace camshaft. Refer to [EM-247, "Disassembly and Assembly"](#).

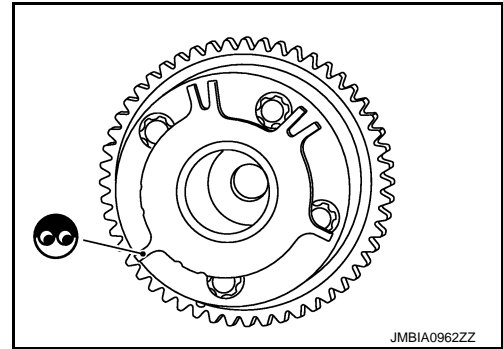

## 6. CHECK TIMING CHAIN INSTALLATION

Check service records for any recent repairs that may cause timing chain misalignment.

Are there any service records that may cause timing chain misalignment?

YES >> Check timing chain installation. Refer to [EM-244, "Inspection"](#).

NO >> GO TO 7.

## 7. CHECK LUBRICATION CIRCUIT

Perform "Inspection of Camshaft Sprocket (INT) Oil Groove". Refer to [EM-255, "Inspection"](#).

Is the inspection result normal?

YES >> GO TO 8.

NO >> Clean lubrication line.

## 8. CHECK INTERMITTENT INCIDENT

Refer to [GI-44, "Intermittent Incident"](#).

>> INSPECTION END

## Component Inspection (Intake Valve Timing Control Solenoid Valve)

INFOID:000000007187462

### 1. CHECK INTAKE VALVE TIMING CONTROL SOLENOID VALVE-I

1. Turn ignition switch OFF.
2. Disconnect intake valve timing control solenoid valve harness connector.
3. Check resistance between intake valve timing control solenoid valve terminals as per the following.

| Terminals         | Resistance                                       |
|-------------------|--|
| 1 and 2           | 7.0 - 7.7 $\Omega$ [at 20°C (68°F)]              |
| 1 or 2 and ground | $\infty \Omega$<br>(Continuity should not exist) |

Is the inspection result normal?

YES >> GO TO 2.

NO >> Replace malfunctioning intake valve timing control solenoid valve. Refer to [EM-231, "Exploded View"](#).

### 2. CHECK INTAKE VALVE TIMING CONTROL SOLENOID VALVE-II

1. Remove intake valve timing control solenoid valve. Refer to [EM-231, "Exploded View"](#).

## P0011, P0021 IVT CONTROL

< DTC/CIRCUIT DIAGNOSIS >

[VK56VD FOR USA AND CANADA]

2. Provide 12 V DC between intake valve timing control solenoid valve terminals 1 and 2, and then interrupt it. Check that the plunger moves as shown in the figure.

**CAUTION:**

**Never apply 12 V DC continuously for 5 seconds or more. Doing so may result in damage to the coil in intake valve timing control solenoid valve.**

**NOTE:**

**Always replace O-ring when intake valve timing control solenoid valve is removed.**

Is the inspection result normal?

YES >> INSPECTION END

NO >> Replace malfunctioning intake valve timing control solenoid valve. Refer to [EM-246. "Exploded View"](#).

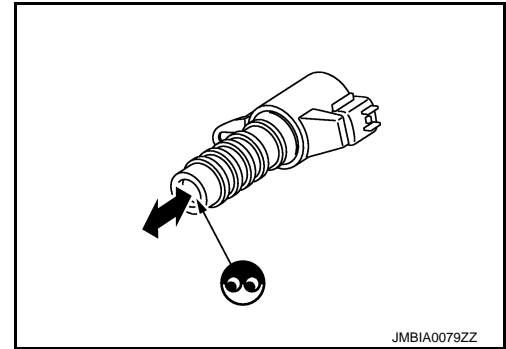



# P0014, P0024 EVT CONTROL

< DTC/CIRCUIT DIAGNOSIS >

[VK56VD FOR USA AND CANADA]

## P0014, P0024 EVT CONTROL

### DTC Logic

INFOID:000000007187463

### DTC DETECTION LOGIC

#### NOTE:

- If DTC P0014 or P0024 is displayed with DTC P0078, P0084 first perform trouble diagnosis for DTC P0078, P0084. Refer to [EC-1182, "DTC Logic"](#).
- If DTC P0014 or P0024 is displayed with DTC P1078, P1084 first perform trouble diagnosis for DTC P1078, P1084. Refer to [EC-1398, "DTC Logic"](#).

| DTC No. | Trouble diagnosis name<br>(Trouble diagnosis content)                    | Detecting condition  | Possible cause   |
|---------|--|--|--|
| P0014   | EXH/V TIM CONT-B1<br>[Exhaust valve timing control performance (bank 1)] | There is a gap between angle of target and phase-control angle degree. | <ul style="list-style-type: none"><li>• Crankshaft position sensor</li><li>• Camshaft position sensor</li><li>• Exhaust valve timing control position sensor</li><li>• Exhaust valve timing control solenoid valve</li><li>• Accumulation of debris to the signal pick-up portion of the camshaft</li><li>• Timing chain installation</li><li>• Foreign matter caught in the oil groove for exhaust valve timing control</li></ul> |
| P0024   | EXH/V TIM CONT-B2<br>[Exhaust valve timing control performance (bank 2)] |  |  |

### DTC CONFIRMATION PROCEDURE

#### 1. PRECONDITIONING

1. Turn ignition switch OFF and wait at least 10 seconds.
2. Turn ignition switch ON.
3. Turn ignition switch OFF and wait at least 10 seconds.

#### TESTING CONDITION:

Before performing the following procedure, confirm that battery voltage is 11 V or more at idle.

>> GO TO 2.

#### 2. PERFORM DTC CONFIRMATION PROCEDURE-I

##### Ⓜ WITH CONSULT

1. Turn ignition switch ON and select "DATA MONITOR" mode with CONSULT.
2. Start engine and warm it up to the normal operating temperature.
3. Maintain the following conditions for at least 6 consecutive seconds.  
Hold the accelerator pedal as steady as possible.

|                |  |
|----------------|--|
| ENG SPEED      | Less than 2,000 rpm (A constant rotation is maintained.) |
| COOLAN TEMP/S  | More than 70°C (158°F)                                   |
| Selector lever | P or N position  |

4. Let engine idle for 10 seconds.
5. Check 1st trip DTC.

##### Ⓜ WITH GST

Follow the procedure "With CONSULT" above.

#### Is 1st trip DTC detected?

- YES >> Proceed to [EC-1170, "Diagnosis Procedure"](#)  
NO >> GO TO 3.

#### 3. PERFORM DTC CONFIRMATION PROCEDURE-II

##### Ⓜ WITH CONSULT

1. Select "DATA MONITOR" mode with CONSULT.
2. Maintain the following conditions for at least 20 consecutive seconds.

# P0014, P0024 EVT CONTROL

[VK56VD FOR USA AND CANADA]

< DTC/CIRCUIT DIAGNOSIS >

|                         |   |
|-------------------------|---|
| ENG SPEED               | 1,500 - 3,175 rpm (A constant rotation is maintained.)  |
| COOLAN TEMP/S           | More than 70°C (158°F)  |
| Selector lever          | 1st or 2nd position   |
| Driving location uphill | Driving vehicle uphill<br>(Increased engine load will help maintain the driving conditions required for this test.) |

## CAUTION:

**Always drive at a safe speed.**

3. Check 1st trip DTC.

 WITH GST

Follow the procedure "With CONSULT" above.

Is 1st trip DTC detected?

YES >> Proceed to [EC-1170, "Diagnosis Procedure"](#)

NO >> INSPECTION END

## Diagnosis Procedure

INFOID:000000007187464

### 1.CHECK OIL PRESSURE WARNING LAMP

1. Start engine.

2. Check that oil pressure warning lamp is not illuminated.

Is oil pressure warning lamp illuminated?

YES >> Refer to [LU-23, "Inspection"](#).

NO >> GO TO 2.

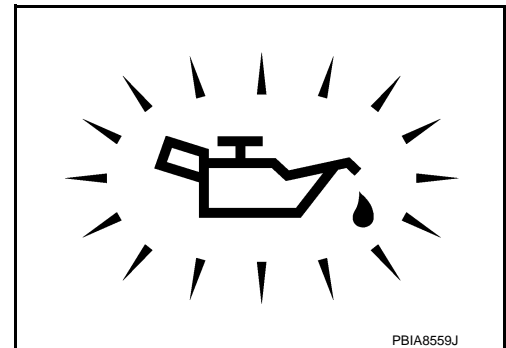

### 2.CHECK EXHAUST VALVE TIMING CONTROL SOLENOID VALVE

Refer to [EC-1171, "Component Inspection \(Exhaust Valve Timing Control Solenoid Valve\)"](#).

Is the inspection result normal?

YES >> GO TO 3.

NO >> Replace malfunctioning exhaust valve timing control solenoid valve. Refer to [EM-231, "Exploded View"](#).

### 3.CHECK EXHAUST VALVE TIMING CONTROL POSITION SENSOR

Refer to [EC-1400, "Component Inspection \(Exhaust Valve Timing Control Position Sensor\)"](#).

Is the inspection result normal?

YES >> GO TO 4.

NO >> Replace malfunctioning exhaust valve timing control position sensor. Refer to [EM-231, "Exploded View"](#).

### 4.CHECK CRANKSHAFT POSITION SENSOR

Refer to [EC-1307, "Component Inspection \(Crankshaft Position Sensor\)"](#).

Is the inspection result normal?

YES >> GO TO 5.

NO >> Replace crankshaft position sensor. Refer to [EM-226, "Exploded View" \(2WD\)](#) or [EM-204, "2WD : Exploded View" \(AWD\)](#)

### 5.CHECK CAMSHAFT POSITION SENSOR

Refer to [EC-1312, "Component Inspection \(Camshaft Position Sensor\)"](#).

Is the inspection result normal?

# P0014, P0024 EVT CONTROL

[VK56VD FOR USA AND CANADA]

< DTC/CIRCUIT DIAGNOSIS >

YES >> GO TO 6.

NO >> Replace malfunctioning camshaft position sensor. Refer to [EM-231, "Exploded View"](#).

## 6.CHECK CAMSHAFT (EXH)

Check the following.

- Accumulation of debris to the signal plate of camshaft front end
- Chipping signal plate of camshaft front end

Is the inspection result normal?

YES >> GO TO 7.

NO >> Remove debris and clean the signal plate of camshaft front end or replace camshaft. Refer to [EM-247, "Disassembly and Assembly"](#).

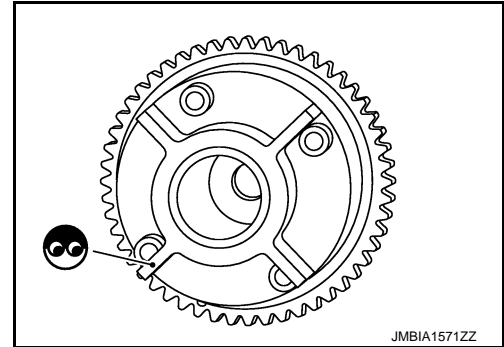

## 7.CHECK TIMING CHAIN INSTALLATION

Check service records for any recent repairs that may cause timing chain misaligned.

Are there any service records that may cause timing chain misaligned?

YES >> Check timing chain installation. Refer to [EM-244, "Inspection"](#).

NO >> GO TO 8.

## 8.CHECK LUBRICATION CIRCUIT

Perform "Inspection of Camshaft Sprocket (EXT) Oil Groove". Refer to [EM-255, "Inspection"](#).

Is the inspection result normal?

YES >> GO TO 9.

NO >> Clean lubrication line.

## 9.CHECK INTERMITTENT INCIDENT

Refer to [GI-44, "Intermittent Incident"](#).

>> INSPECTION END

## Component Inspection (Echaust Valve Timing Control Solenoid Valve)

INFOID:000000007187465

### 1.CHECK EXHAUST VALVE TIMING CONTROL SOLENOID VALVE-I

1. Turn ignition switch OFF.
2. Disconnect exhaust valve timing control solenoid valve harness connector.
3. Check resistance between exhaust valve timing control solenoid valve terminals as per the following.

| Terminals         | Resistance                                       |
|-------------------|--|
| 1 and 2           | 7.0 - 7.7 $\Omega$ [at 20°C (68°F)]              |
| 1 or 2 and ground | $\infty \Omega$<br>(Continuity should not exist) |

Is the inspection result normal?

YES >> GO TO 2.

NO >> Replace malfunctioning exhaust valve timing control solenoid valve. Refer to [EM-231, "Exploded View"](#).

### 2.CHECK EXHAUST VALVE TIMING CONTROL SOLENOID VALVE-II

1. Remove exhaust valve timing control solenoid valve. Refer to [EM-231, "Exploded View"](#).

## P0014, P0024 EVT CONTROL

< DTC/CIRCUIT DIAGNOSIS >

[VK56VD FOR USA AND CANADA]

2. Provide 12 V DC between exhaust valve timing control solenoid valve terminals 1 and 2, and then interrupt it. Check that the plunger moves as shown in the figure.

**CAUTION:**

**Do not apply 12 V DC continuously for 5 seconds or more. Doing so may result in damage to the coil in exhaust valve timing control solenoid valve.**

**NOTE:**

**Always replace O-ring when exhaust valve timing control solenoid valve is removed.**

Is the inspection result normal?

YES >> INSPECTION END

NO >> Replace malfunctioning exhaust valve timing control solenoid valve. Refer to [EM-231, "Exploded View"](#).

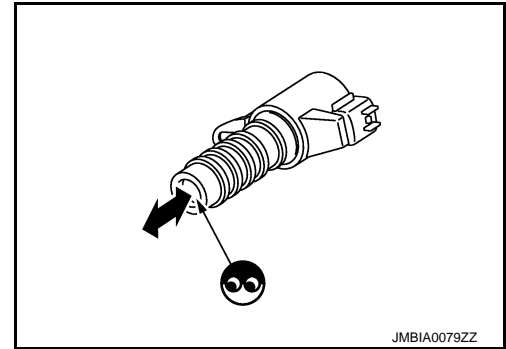

# P0031, P0032, P0051, P0052 A/F SENSOR 1 HEATER

< DTC/CIRCUIT DIAGNOSIS >

[VK56VD FOR USA AND CANADA]

## P0031, P0032, P0051, P0052 A/F SENSOR 1 HEATER

### DTC Logic

INFOID:000000007187466

### DTC DETECTION LOGIC

| DTC No. | Trouble diagnosis<br>(Trouble diagnosis content)                         | DTC detecting condition   | Possible cause   |
|---------|--|---|--|
| P0031   | A/F SEN1 HTR (B1)<br>[A/F sensor 1 heater (bank 1) control circuit low]  | The current amperage in the A/F sensor 1 heater circuit is out of the normal range.<br>(An excessively low voltage signal is sent to ECM through the A/F sensor 1 heater.)  | <ul style="list-style-type: none"> <li>Harness or connectors (The A/F sensor 1 heater circuit is open or shorted.)</li> <li>A/F sensor 1 heater</li> </ul> |
| P0032   | A/F SEN1 HTR (B1)<br>[A/F sensor 1 heater (bank 1) control circuit high] | The current amperage in the A/F sensor 1 heater circuit is out of the normal range.<br>(An excessively high voltage signal is sent to ECM through the A/F sensor 1 heater.) | <ul style="list-style-type: none"> <li>Harness or connectors (The A/F sensor 1 heater circuit is shorted.)</li> <li>A/F sensor 1 heater</li> </ul>         |
| P0051   | A/F SEN1 HTR (B2)<br>[A/F sensor 1 heater (bank 2) control circuit low]  | The current amperage in the A/F sensor 1 heater circuit is out of the normal range.<br>(An excessively low voltage signal is sent to ECM through the A/F sensor 1 heater.)  | <ul style="list-style-type: none"> <li>Harness or connectors (The A/F sensor 1 heater circuit is open or shorted.)</li> <li>A/F sensor 1 heater</li> </ul> |
| P0052   | A/F SEN1 HTR (B2)<br>[A/F sensor 1 heater (bank 2) control circuit high] | The current amperage in the A/F sensor 1 heater circuit is out of the normal range.<br>(An excessively high voltage signal is sent to ECM through the A/F sensor 1 heater.) | <ul style="list-style-type: none"> <li>Harness or connectors (The A/F sensor 1 heater circuit is shorted.)</li> <li>A/F sensor 1 heater</li> </ul>         |

### DTC CONFIRMATION PROCEDURE

#### 1. PRECONDITIONING

- Turn ignition switch OFF and wait at least 10 seconds.
- Turn ignition switch ON.
- Turn ignition switch OFF and wait at least 10 seconds.

#### TESTING CONDITION:

Before performing the following procedure, confirm that battery voltage is 11 V or more at idle.

>> GO TO 2.

#### 2. PERFORM DTC CONFIRMATION PROCEDURE

- Start engine and let it idle for at least 10 seconds.
- Check 1st trip DTC.

Is 1st trip DTC detected?

- YES >> Proceed to [EC-1173, "Diagnosis Procedure"](#).  
 NG >> INSPECTION END

### Diagnosis Procedure

INFOID:000000007187467

#### 1. CHECK AIR FUEL RATIO (A/F) SENSOR 1 POWER SUPPLY CIRCUIT

- Disconnect air fuel ratio (A/F) sensor 1 harness connector.
- Turn ignition switch ON.
- Check the voltage between A/F sensor 1 harness connector and ground.

| DTC          | A/F sensor 1 |           |          | Ground | Voltage         |
|--------------|--------------|-----------|----------|--------|-----------------|
|              | Bank         | Connector | Terminal |        |                 |
| P0031, P0032 | 1            | F23       | 4        | Ground | Battery voltage |
| P0051, P0052 | 2            | F24       | 4        |        |                 |

Is the inspection result normal?

- YES >> GO TO 3.  
 NO >> GO TO 2.

# P0031, P0032, P0051, P0052 A/F SENSOR 1 HEATER

< DTC/CIRCUIT DIAGNOSIS >

[VK56VD FOR USA AND CANADA]

## 2. DETECT MALFUNCTIONING PART

Check the following.

- 15 A fuse (No. 45)
- Harness for open or short between A/F sensor 1 and fuse
- Loose or poor connection for each connector and harness

>> Repair or replace harness or connectors.

## 3. CHECK A/F SENSOR 1 HEATER OUTPUT SIGNAL CIRCUIT FOR OPEN AND SHORT

1. Turn ignition switch OFF.
2. Disconnect ECM harness connector.
3. Check the continuity between A/F sensor 1 harness connector and ECM harness connector.

| DTC          | A/F sensor 1 |           |          | ECM       |          | Continuity |
|--------------|--------------|-----------|----------|-----------|----------|------------|
|              | Bank         | Connector | Terminal | Connector | Terminal |            |
| P0031, P0032 | 1            | F23       | 2        | F110      | 48       | Existed    |
| P0051, P0052 | 2            | F24       | 2        |           | 53       |            |

4. Also check harness for short to ground and short to power.

Is the inspection result normal?

YES >> GO TO 4.

NO >> Repair open circuit, short to ground or short to power in harness or connectors.

## 4. CHECK A/F SENSOR 1 HEATER

Refer to [EC-1174, "Component Inspection \(A/F Sensor 1 Heater\)"](#).

Is the inspection result normal?

YES >> GO TO 6.

NO >> GO TO 5.

## 5. REPLACE A/F SENSOR 1

Replace malfunctioning A/F sensor 1. Refer to [EM-223, "Exploded View"](#).

### CAUTION:

- Discard any A/F sensor which has been dropped from a height of more than 0.5 m (19.7 in) onto a hard surface such as a concrete floor; use a new one.
- Before installing new A/F sensor, clean exhaust system threads using Oxygen Sensor Thread Cleaner [commercial service tool (J-43897-18 or J-43897-12)] and approved anti-seize lubricant (commercial service tool).

>> INSPECTION END

## 6. CHECK INTERMITTENT INCIDENT

Perform [GI-44, "Intermittent Incident"](#).

>> INSPECTION END

## Component Inspection (A/F Sensor 1 Heater)

INFOID:000000007187468

### 1. CHECK AIR FUEL RATIO (A/F) SENSOR 1

1. Turn ignition switch OFF.
2. Disconnect air fuel ratio (A/F) sensor 1 harness connector.
3. Check resistance between A/F sensor 1 terminals as per the following.

| Terminal | Resistance                            |
|----------|---------------------------------------|
| 2 and 5  | 1.98 - 2.66 $\Omega$ [at 25°C (77°F)] |

# P0031, P0032, P0051, P0052 A/F SENSOR 1 HEATER

< DTC/CIRCUIT DIAGNOSIS >

[VK56VD FOR USA AND CANADA]

| Terminal      | Resistance                    |
|---------------|-------------------------------|
| 2 and 3, 4, 6 | $\infty \Omega$               |
| 5 and 3, 4, 6 | (Continuity should not exist) |

Is the inspection result normal?

YES >> INSPECTION END

NO >> GO TO 2.

## 2.REPLACE A/F SENSOR 1

Replace malfunctioning A/F sensor 1. Refer to [EM-223, "Exploded View"](#).

### CAUTION:

- Discard any A/F sensor which has been dropped from a height of more than 0.5 m (19.7 in) onto a hard surface such as a concrete floor; use a new one.
- Before installing new A/F sensor, clean exhaust system threads using Oxygen Sensor Thread Cleaner [commercial service tool (J-43897-18 or J-43897-12)] and approved anti-seize lubricant (commercial service tool).

>> INSPECTION END

A

EC

C

D

E

F

G

H

I

J

K

L

M

N

O

P

# P0037, P0038, P0057, P0058 HO2S2 HEATER

< DTC/CIRCUIT DIAGNOSIS >

[VK56VD FOR USA AND CANADA]

## P0037, P0038, P0057, P0058 HO2S2 HEATER

### DTC Logic

INFOID:000000007187469

### DTC DETECTION LOGIC

| DTC No. | Trouble diagnosis name<br>(Trouble diagnosis content)                           | DTC detecting condition   | Possible cause  |
|---------|---|---|---|
| P0037   | HO2S2 HTR (B1)<br>[Heated oxygen sensor 2 heater (bank 1) control circuit low]  | The current amperage in the heated oxygen sensor 2 heater circuit is out of the normal range.<br>(An excessively low voltage signal is sent to ECM through the heated oxygen sensor 2 heater.)  | <ul style="list-style-type: none"><li>• Harness or connectors<br/>(The heated oxygen sensor 2 heater circuit is open or shorted.)</li><li>• Heated oxygen sensor 2 heater</li></ul> |
| P0038   | HO2S2 HTR (B1)<br>[Heated oxygen sensor 2 heater (bank 1) control circuit high] | The current amperage in the heated oxygen sensor 2 heater circuit is out of the normal range.<br>(An excessively high voltage signal is sent to ECM through the heated oxygen sensor 2 heater.) | <ul style="list-style-type: none"><li>• Harness or connectors<br/>(The heated oxygen sensor 2 heater circuit is shorted.)</li><li>• Heated oxygen sensor 2 heater</li></ul>         |
| P0057   | HO2S2 HTR (B2)<br>[Heated oxygen sensor 2 heater (bank 2) control circuit low]  | The current amperage in the heated oxygen sensor 2 heater circuit is out of the normal range.<br>(An excessively low voltage signal is sent to ECM through the heated oxygen sensor 2 heater.)  | <ul style="list-style-type: none"><li>• Harness or connectors<br/>(The heated oxygen sensor 2 heater circuit is open or shorted.)</li><li>• Heated oxygen sensor 2 heater</li></ul> |
| P0058   | HO2S2 HTR (B2)<br>[Heated oxygen sensor 2 heater (bank 2) control circuit high] | The current amperage in the heated oxygen sensor 2 heater circuit is out of the normal range.<br>(An excessively high voltage signal is sent to ECM through the heated oxygen sensor 2 heater.) | <ul style="list-style-type: none"><li>• Harness or connectors<br/>(The heated oxygen sensor 2 heater circuit is shorted.)</li><li>• Heated oxygen sensor 2 heater</li></ul>         |

### DTC CONFIRMATION PROCEDURE

#### 1. PRECONDITIONING

1. Turn ignition switch OFF and wait at least 10 seconds.
2. Turn ignition switch ON.
3. Turn ignition switch OFF and wait at least 10 seconds.

#### TESTING CONDITION:

Before performing the following procedure, confirm that battery voltage is 11 V or more at idle.

>> GO TO 2.

#### 2. PERFORM DTC CONFIRMATION PROCEDURE

1. Start engine and warm it up to the normal operating temperature.
2. Turn ignition switch OFF and wait at least 10 seconds.
3. Turn ignition switch ON.
4. Turn ignition switch OFF and wait at least 10 seconds.
5. Start engine and keep the engine speed between 3,500 and 4,000 rpm for at least 1 minute under no load.
6. Let engine idle for 1 minute.
7. Check 1st trip DTC.

Is 1st trip DTC detected?

- YES >> Proceed to [EC-1176. "Diagnosis Procedure"](#).  
NO >> INSPECTION END

### Diagnosis Procedure

INFOID:000000007187470

#### 1. CHECK HEATED OXYGEN SENSOR 2 (HO2S2) POWER SUPPLY CIRCUIT

1. Disconnect heated oxygen sensor 2 (HO2S2) harness connector.
2. Turn ignition switch ON.
3. Check the voltage between HO2S2 harness connector and ground.



# P0037, P0038, P0057, P0058 HO2S2 HEATER

< DTC/CIRCUIT DIAGNOSIS >

[VK56VD FOR USA AND CANADA]

| DTC          | HO2S2 |           |          | Ground | Voltage         |
|--------------|-------|-----------|----------|--------|-----------------|
|              | Bank  | Connector | Terminal |        |                 |
| P0037, P0038 | 1     | F87       | 2        | Ground | Battery voltage |
| P0057, P0058 | 2     | F88       | 2        |        |                 |

Is the inspection result normal?

- YES >> GO TO 3.
- NO >> GO TO 2.

## 2. DETECT MALFUNCTIONING PART

Check the following.

- 15 A fuse (No. 45)
- Harness for open or short between heated oxygen sensor 2 and fuse
- Loose or poor connection for each connector and harness

>> Repair open circuit, short to ground or short to power in harness or connectors.

## 3. CHECK HO2S2 OUTPUT SIGNAL CIRCUIT FOR OPEN AND SHORT

1. Turn ignition switch OFF.
2. Disconnect ECM harness connector.
3. Check the continuity between HO2S2 harness connector and ECM harness connector.

| DTC          | HO2S2 |           |          | ECM       |          | Continuity |
|--------------|-------|-----------|----------|-----------|----------|------------|
|              | Bank  | Connector | Terminal | Connector | Terminal |            |
| P0037, P0038 | 1     | F87       | 3        | F110      | 47       | Existed    |
| P0057, P0058 | 2     | F88       | 3        |           | 52       |            |

4. Also check harness for short to ground and short to power.

Is the inspection result normal?

- YES >> GO TO 4.
- NO >> Repair open circuit, short to ground or short to power in harness or connectors.

## 4. CHECK HO2S2 HEATER

Refer to [EC-1178, "Component Inspection \(HO2 Sensor 2 Heater\)"](#).

Is the inspection result normal?

- YES >> GO TO 6.
- NO >> GO TO 5.

## 5. REPLACE HEATED OXYGEN SENSOR 2

Replace malfunctioning heated oxygen sensor 2. Refer to [EM-223, "Exploded View"](#).

### CAUTION:

- Discard any heated oxygen sensor which has been dropped from a height of more than 0.5 m (19.7 in) onto a hard surface such as a concrete floor; use a new one.
- Before installing new oxygen sensor, clean exhaust system threads using Oxygen Sensor Thread Cleaner [commercial service tool (J-43897-18 or J-43897-12)] and approved anti-seize lubricant (commercial service tool).

>> INSPECTION END

## 6. CHECK INTERMITTENT INCIDENT

Refer to [GI-44, "Intermittent Incident"](#).

>> INSPECTION END

# P0037, P0038, P0057, P0058 HO2S2 HEATER

< DTC/CIRCUIT DIAGNOSIS >

[VK56VD FOR USA AND CANADA]

## Component Inspection (HO2 Sensor 2 Heater)

INFOID:000000007187471

### 1. CHECK HEATED OXYGEN SENSOR 2 HEATER

1. Turn ignition switch OFF.
2. Disconnect heated oxygen sensor 2 (HO2S2) harness connector.
3. Check resistance between HO2S2 terminals as follows.

| Terminal   | Resistance                          |
|------------|-------------------------------------|
| 2 and 3    | 3.4 - 4.4 $\Omega$ [at 25°C (77°F)] |
| 2 and 1, 4 | $\infty \Omega$                     |
| 3 and 1, 4 | (Continuity should not exist)       |

Is the inspection result normal?

- YES >> INSPECTION END  
NO >> GO TO 2.

### 2. REPLACE HEATED OXYGEN SENSOR 2

Replace malfunctioning heated oxygen sensor 2. Refer to [EX-7, "VK56VD : Exploded View"](#).

#### **CAUTION:**

- Discard any heated oxygen sensor which has been dropped from a height of more than 0.5 m (19.7 in) onto a hard surface such as a concrete floor; use a new one.
- Before installing new oxygen sensor, clean exhaust system threads using Oxygen Sensor Thread Cleaner [commercial service tool (J-43897-18 or J-43897-12)] and approved anti-seize lubricant (commercial service tool).

>> INSPECTION END

# P0075, P0081 IVT CONTROL SOLENOID VALVE

< DTC/CIRCUIT DIAGNOSIS >

[VK56VD FOR USA AND CANADA]

## P0075, P0081 IVT CONTROL SOLENOID VALVE

### DTC Logic

INFOID:000000007187472

### DTC DETECTION LOGIC

| DTC No. | Trouble diagnosis name<br>(Trouble diagnosis content)                               | DTC detecting condition  | Possible cause  |
|---------|---|--|---|
| P0075   | INT/V TIM V/CIR-B1<br>[Intake valve timing control solenoid valve (bank 1) circuit] | An improper voltage is sent to the ECM through intake valve timing control solenoid valve. | <ul style="list-style-type: none"><li>• Harness or connectors (Intake valve timing control solenoid valve circuit is open or shorted.)</li><li>• Intake valve timing control solenoid valve</li></ul> |
| P0081   | INT/V TIM V/CIR-B2<br>[Intake valve timing control solenoid valve (bank 2) circuit] |  |   |

### DTC CONFIRMATION PROCEDURE

#### 1. PRECONDITIONING

If DTC Confirmation Procedure has been previously conducted, always perform the following procedure before conducting the next test.

1. Turn ignition switch OFF and wait at least 10 seconds.
2. Turn ignition switch ON.
3. Turn ignition switch OFF and wait at least 10 seconds.

>> GO TO 2.

#### 2. PERFORM DTC CONFIRMATION PROCEDURE

1. Start engine and let it idle for 5 seconds.
2. Check 1st trip DTC.

Is 1st trip DTC detected?

- YES >> Proceed to [EC-1179, "Diagnosis Procedure"](#).  
NO >> INSPECTION END

### Diagnosis Procedure

INFOID:000000007187473

#### 1. CHECK INTAKE VALVE TIMING CONTROL SOLENOID VALVE POWER SUPPLY CIRCUIT

1. Turn ignition switch OFF.
2. Disconnect intake valve timing (IVT) control solenoid valve harness connector.
3. Turn ignition switch ON.
4. Check the voltage between IVT control solenoid valve harness connector and ground.

| DTC   | IVT control solenoid valve |           |          | Ground | Voltage         |
|-------|----------------------------|-----------|----------|--------|-----------------|
|       | Bank                       | Connector | Terminal |        |                 |
| P0075 | 1                          | F22       | 2        | Ground | Battery voltage |
| P0081 | 2                          | F21       | 2        |        |                 |

Is the inspection result normal?

- YES >> GO TO 3.  
NO >> GO TO 2.

#### 2. DETECT MALFUNCTIONING PART

Check the following.

- Harness for open or short between IVT control solenoid valve and IPDM E/R
- Loose or poor connection for each connector and harness

>> Repair open circuit, short to ground or short to power in harness or connectors.

# P0075, P0081 IVT CONTROL SOLENOID VALVE

[VK56VD FOR USA AND CANADA]

< DTC/CIRCUIT DIAGNOSIS >

## 3. CHECK IVT CONTROL SOLENOID VALVE OUTPUT SIGNAL CIRCUIT FOR OPEN AND SHORT

1. Turn ignition switch OFF.
2. Disconnect ECM harness connector.
3. Check the continuity between IVT control solenoid valve harness connector and ECM harness connector.

| DTC   | IVT control solenoid valve |           |          | ECM       |          | Continuity |
|-------|----------------------------|-----------|----------|-----------|----------|------------|
|       | Bank                       | Connector | Terminal | Connector | Terminal |            |
| P0075 | 1                          | F22       | 1        | F110      | 54       | Existed    |
| P0081 | 2                          | F21       | 1        |           | 49       |            |

4. Also check harness for short to ground and short to power.

Is the inspection result normal?

YES >> GO TO 4.

NO >> Repair open circuit, short to ground or short to power in harness or connectors.

## 4. CHECK IVT CONTROL SOLENOID VALVE

Refer to [EC-1180, "Component Inspection \(Intake Valve Timing Control Solenoid Valve\)"](#).

Is the inspection result normal?

YES >> GO TO 5.

NO >> Replace malfunctioning IVT control solenoid valve. Refer to [EM-231, "Exploded View"](#).

## 5. CHECK INTERMITTENT INCIDENT

Refer to [GI-44, "Intermittent Incident"](#).

>> INSPECTION END

## Component Inspection (Intake Valve Timing Control Solenoid Valve)

INFOID:000000007187474

### 1. CHECK INTAKE VALVE TIMING CONTROL SOLENOID VALVE-I

1. Turn ignition switch OFF.
2. Disconnect intake valve timing control solenoid valve harness connector.
3. Check resistance between intake valve timing control solenoid valve terminals as per the following.

| Terminals         | Resistance                                       |
|-------------------|--|
| 1 and 2           | 7.0 - 7.7 $\Omega$ [at 20°C (68°F)]              |
| 1 or 2 and ground | $\infty \Omega$<br>(Continuity should not exist) |

Is the inspection result normal?

YES >> GO TO 2.

NO >> Replace malfunctioning intake valve timing control solenoid valve. Refer to [EM-231, "Exploded View"](#).

### 2. CHECK INTAKE VALVE TIMING CONTROL SOLENOID VALVE-II

1. Remove intake valve timing control solenoid valve. Refer to [EM-231, "Exploded View"](#).
2. Provide 12 V DC between intake valve timing control solenoid valve terminals 1 and 2, and then interrupt it. Check that the plunger moves as shown in the figure.

#### CAUTION:

Never apply 12 V DC continuously for 5 seconds or more. Doing so may result in damage to the coil in intake valve timing control solenoid valve.

#### NOTE:

Always replace O-ring when intake valve timing control solenoid valve is removed.

Is the inspection result normal?

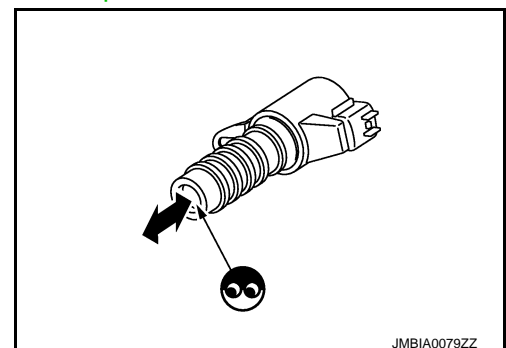

JMBIA0079ZZ

# P0075, P0081 IVT CONTROL SOLENOID VALVE

[VK56VD FOR USA AND CANADA]

< DTC/CIRCUIT DIAGNOSIS >

YES >> INSPECTION END

NO >> Replace malfunctioning intake valve timing control solenoid valve. Refer to [EM-231, "Exploded View"](#).

A

EC

C

D

E

F

G

H

I

J

K

L

M

N

O

P

# P0078, P0084 EVT CONTROL SOLENOID VALVE

< DTC/CIRCUIT DIAGNOSIS >

[VK56VD FOR USA AND CANADA]

## P0078, P0084 EVT CONTROL SOLENOID VALVE

### DTC Logic

INFOID:000000007187475

### DTC DETECTION LOGIC

| DTC No. | Trouble diagnosis name<br>(Trouble diagnosis content)                                | DTC detecting condition   | Possible cause  |
|---------|--|---|---|
| P0078   | EX V/T ACT/CIRC-B1<br>[Exhaust valve timing control solenoid valve (bank 1) circuit] | An improper voltage is sent to the ECM through exhaust valve timing control solenoid valve. | <ul style="list-style-type: none"><li>• Harness or connectors (Exhaust valve timing control solenoid valve circuit is open or shorted.)</li><li>• Exhaust valve timing control solenoid valve</li></ul> |
| P0084   | EX V/T ACT/CIRC-B2<br>[Exhaust valve timing control solenoid valve (bank 2) circuit] |   |   |

### DTC CONFIRMATION PROCEDURE

#### 1. PRECONDITIONING

If DTC Confirmation Procedure has been previously conducted, always perform the following procedure before conducting the next test.

1. Turn ignition switch OFF and wait at least 10 seconds.
2. Turn ignition switch ON.
3. Turn ignition switch OFF and wait at least 10 seconds.

>> GO TO 2.

#### 2. PERFORM DTC CONFIRMATION PROCEDURE

1. Start engine and let it idle for 5 seconds.
2. Check 1st trip DTC.

Is 1st trip DTC detected?

- YES >> Proceed to [EC-1182, "Diagnosis Procedure"](#).  
NO >> INSPECTION END

### Diagnosis Procedure

INFOID:000000007187476

#### 1. CHECK EXHAUST VALVE TIMING CONTROL SOLENOID VALVE POWER SUPPLY CIRCUIT

1. Turn ignition switch OFF.
2. Disconnect exhaust valve timing (EVT) control solenoid valve harness connector.
3. Turn ignition switch ON.
4. Check the voltage between EVT control solenoid valve harness connector and ground.

| DTC   | EVT control solenoid valve |           |          | Ground | Voltage         |
|-------|----------------------------|-----------|----------|--------|-----------------|
|       | Bank                       | Connector | Terminal |        |                 |
| P0078 | 1                          | F26       | 2        | Ground | Battery voltage |
| P0084 | 2                          | F25       | 2        |        |                 |

Is the inspection result normal?

- YES >> GO TO 3.  
NO >> GO TO 2.

#### 2. DETECT MALFUNCTIONING PART

Check the following.

- Harness for open or short between EVT control solenoid valve and IPDM E/R
- Loose or poor connection for each connector and harness

>> Repair open circuit, short to ground or short to power in harness or connectors.

# P0078, P0084 EVT CONTROL SOLENOID VALVE

< DTC/CIRCUIT DIAGNOSIS >

[VK56VD FOR USA AND CANADA]

## 3. CHECK EVT CONTROL SOLENOID VALVE OUTPUT SIGNAL CIRCUIT FOR OPEN AND SHORT

1. Turn ignition switch OFF.
2. Disconnect ECM harness connector.
3. Check the continuity between EVT control solenoid valve harness connector and ECM harness connector.

| DTC   | EVT control solenoid valve |           |          | ECM       |          | Continuity |
|-------|----------------------------|-----------|----------|-----------|----------|------------|
|       | Bank                       | Connector | Terminal | Connector | Terminal |            |
| P0078 | 1                          | F26       | 1        | F110      | 55       | Existed    |
| P0084 | 2                          | F25       | 1        |           | 50       |            |

4. Also check harness for short to ground and short to power.

Is the inspection result normal?

YES >> GO TO 4.

NO >> Repair open circuit, short to ground or short to power in harness or connectors.

## 4. CHECK EVT CONTROL SOLENOID VALVE

Refer to [EC-1171, "Component Inspection \(Echaust Valve Timing Control Solenoid Valve\)"](#).

Is the inspection result normal?

YES >> GO TO 5.

NO >> Replace malfunctioning EVT control solenoid valve. Refer to [EM-231, "Exploded View"](#).

## 5. CHECK INTERMITTENT INCIDENT

Refer to [GI-44, "Intermittent Incident"](#).

>> INSPECTION END

## Component Inspection (Echaust Valve Timing Control Solenoid Valve)

INFOID:000000007187477

### 1. CHECK EXHAUST VALVE TIMING CONTROL SOLENOID VALVE-I

1. Turn ignition switch OFF.
2. Disconnect exhaust valve timing control solenoid valve harness connector.
3. Check resistance between exhaust valve timing control solenoid valve terminals as per the following.

| Terminals         | Resistance                                       |
|-------------------|--|
| 1 and 2           | 7.0 - 7.7 $\Omega$ [at 20°C (68°F)]              |
| 1 or 2 and ground | $\infty \Omega$<br>(Continuity should not exist) |

Is the inspection result normal?

YES >> GO TO 2.

NO >> Replace malfunctioning exhaust valve timing control solenoid valve. Refer to [EM-231, "Exploded View"](#).

### 2. CHECK EXHAUST VALVE TIMING CONTROL SOLENOID VALVE-II

1. Remove exhaust valve timing control solenoid valve. Refer to [EM-231, "Exploded View"](#).

## P0078, P0084 EVT CONTROL SOLENOID VALVE

[VK56VD FOR USA AND CANADA]

< DTC/CIRCUIT DIAGNOSIS >

2. Provide 12 V DC between exhaust valve timing control solenoid valve terminals 1 and 2, and then interrupt it. Check that the plunger moves as shown in the figure.

**CAUTION:**

**Do not apply 12 V DC continuously for 5 seconds or more. Doing so may result in damage to the coil in exhaust valve timing control solenoid valve.**

**NOTE:**

**Always replace O-ring when exhaust valve timing control solenoid valve is removed.**

Is the inspection result normal?

YES >> INSPECTION END

NO >> Replace malfunctioning exhaust valve timing control solenoid valve. Refer to [EM-231, "Exploded View"](#).

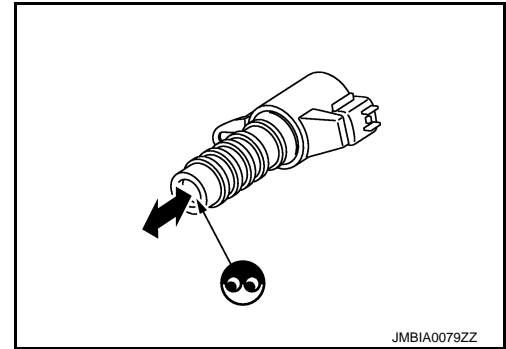



# P008A LOW FUEL PRESSURE CONTROL SYSTEM

< DTC/CIRCUIT DIAGNOSIS >

[VK56VD FOR USA AND CANADA]

## P008A LOW FUEL PRESSURE CONTROL SYSTEM

### DTC Logic

INFOID:000000007187478

#### DTC DETECTION LOGIC

##### NOTE:

If DTC P008A is displayed with DTC P1197, first perform the trouble diagnosis for DTC P1197. Refer to [EC-1412, "DTC Logic"](#).

| DTC No. | Trouble diagnosis name    | DTC detecting condition  | Possible cause  |
|---------|---------------------------|--|---|
| P008A   | Low fuel pressure too low | A condition of low fuel pressure 0.23 MPa (2.3 bar, 2.346 kg/cm <sup>2</sup> , 33.35 psi) or less continues for 5 seconds or more after warming up the engine. | <ul style="list-style-type: none"><li>• Harness or connectors (The low pressure fuel pump circuit is open or shorted.)</li><li>• Low pressure fuel pump</li><li>• Fuel pressure regulator</li><li>• Low pressure fuel system</li><li>• Out of gas</li></ul> |

#### DTC CONFIRMATION PROCEDURE

##### 1. PRECONDITIONING

1. Turn ignition switch OFF and wait at least 10 seconds.
2. Turn ignition switch ON.
3. Turn ignition switch OFF and wait at least 10 seconds.

##### TESTING CONDITION:

Before performing the following procedure, confirm that battery voltage is 11 V or more at idle.

>> GO TO 2.

##### 2. PERFORM DTC CONFIRMATION PROCEDURE

1. Check that the fuel tank is 1/8 full of fuel.
2. Start the engine and warm it up to the normal operating temperature.

##### NOTE:

When replacing ECM, warm up the engine until "COOLAN TEMP/S" on "DATA MONITOR" of CONSULT reaches at least 70°C (158°F).

3. Let the engine at idle for 60 seconds.
4. Check 1st trip DTC.

Is 1st trip DTC detected?

- YES >> Proceed to [EC-1185, "Diagnosis Procedure"](#).  
NO >> INSPECTION END

#### Diagnosis Procedure

INFOID:000000007187479

##### 1. PERFORM LOW PRESSURE FUEL PUMP COMPONENT FUNCTION CHECK

Refer to [EC-1531, "Component Function Check"](#).

Is the inspection result normal?

- YES >> GO TO 2.  
NO >> Perform low pressure fuel pump diagnosis. Refer to [EC-1531, "Diagnosis Procedure"](#).

##### 2. CHECK FUEL LEAKAGE

1. Start the engine.
2. Visually check that the low fuel pressure system has no fuel leakage.

Is inspection result normal?

- YES >> GO TO 3.  
NO >> Repair or replace error-detected parts.

##### 3. CHECK LOW PRESSURE FUEL PIPING AND HOSE

1. Turn ignition switch OFF.

## P008A LOW FUEL PRESSURE CONTROL SYSTEM

< DTC/CIRCUIT DIAGNOSIS >

[VK56VD FOR USA AND CANADA]

2. Check that the low pressure fuel piping and hose have no breakage, bend, and crush. Refer to [FL-4, "Inspection"](#).

Is inspection result normal?

- YES >> Replace fuel level sensor unit and fuel pump (main) (fuel pressure regulator malfunction). Refer to [FL-6, "Removal and Installation"](#).
- NO >> Repair or replace error-detected parts.

# P008B LOW FUEL PRESSURE CONTROL SYSTEM

< DTC/CIRCUIT DIAGNOSIS >

[VK56VD FOR USA AND CANADA]

## P008B LOW FUEL PRESSURE CONTROL SYSTEM

### DTC Logic

INFOID:000000007187480

### DTC DETECTION LOGIC

| DTC No. | Trouble diagnosis name     | DTC detecting condition  | Possible cause  |
|---------|----------------------------|--|---|
| P008B   | Low fuel pressure too high | A condition of low fuel pressure 0.67 MPa (6.7 bar, 6.834 kg/cm <sup>2</sup> , 97.15 psi) or more continues for 5 seconds or more after warming up the engine. | <ul style="list-style-type: none"> <li>• Harness or connectors (The low pressure fuel pump circuit is open or shorted.)</li> <li>• Fuel pressure regulator</li> </ul> |

### DTC CONFIRMATION PROCEDURE

#### 1. PRECONDITIONING

If DTC Confirmation Procedure has been previously conducted, always perform the following procedure before conducting the next test.

1. Turn ignition switch OFF and wait at least 10 seconds.
2. Turn ignition switch ON.
3. Turn ignition switch OFF and wait at least 10 seconds.

#### TESTING CONDITION:

Before performing the following procedure, confirm that battery voltage is 11 V or more at idle.

>> GO TO 2.

#### 2. PERFORM DTC CONFIRMATION PROCEDURE

1. Start the engine and keep the engine speed at idle for 60 seconds.
2. Check 1st trip DTC.

#### Is 1st trip DTC detected?

- YES >> Proceed to [EC-1187, "Diagnosis Procedure"](#).  
 NO >> INSPECTION END

### Diagnosis Procedure

INFOID:000000007187481

#### 1. CHECK FUEL PUMP CONTROL MODULE (FPCM) SIGNAL

Refer to [EC-1420, "Component Inspection \(FPCM\)"](#).

#### Is the inspection result normal?

- YES >> GO TO 2.  
 NO >> Replace FPCM. Refer to [EC-1555, "Removal and Installation"](#).

#### 2. CHECK FUEL PUMP CONTROL CIRCUIT

1. Turn ignition switch OFF.
2. Disconnect FPCM harness connector and fuel level sensor unit and fuel pump (main) harness connector.
3. Check the continuity between FPCM harness connector and fuel level sensor unit and fuel pump (main) harness connector.

| FPCM      |          | Fuel level sensor unit and fuel pump (main) |          | Continuity |
|-----------|----------|---|----------|------------|
| Connector | Terminal | Connector                                   | Terminal |            |
| B221      | 6        | B241  | 3        | Existed    |
|           | 7        |   | 1        |            |

4. Also check harness for short to ground and short to power.

#### Is inspection result normal?

- YES >> Replace fuel level sensor unit and fuel pump (main) (fuel pressure regulator malfunction). Refer to [FL-6, "Removal and Installation"](#).  
 NO >> Repair or replace error-detected parts.

# P0087 FRP CONTROL SYSTEM

< DTC/CIRCUIT DIAGNOSIS >

[VK56VD FOR USA AND CANADA]

## P0087 FRP CONTROL SYSTEM

### DTC Logic

INFOID:000000007768692

### DTC DETECTION LOGIC

#### NOTE:

- If DTC P0087 is displayed with DTC P0090 and/or P1197, first perform the trouble diagnosis for DTC P0090 and/or P1197.
- DTC P0087 may be displayed when running out of gas or air accumulation.

| DTC No. | Trouble diagnosis name<br>(Trouble diagnosis content) | DTC detecting condition   | Possible cause   |
|---------|---|---|--|
| P0087   | LOW FUEL PRES<br>(High fuel pressure too low)         | <ul style="list-style-type: none"><li>• Fuel rail pressure does not reach 1.3 MPa (13.3 kg/cm<sup>2</sup>, 188.5 psi) at engine cold start [water temperature 5°C (41°F) – 40°C (104°F)].</li><li>• Fuel rail pressure remains at 8.5 MPa (86.7 kg/cm<sup>2</sup>, 1232.8 psi) or less for 1 second or more during engine idle condition after cold start [water temperature 5°C (41°F) – 40°C (104°F)].</li><li>• The following condition continues for 5 seconds or more after engine start (regardless of water temperature):<br/>Target fuel pressure – Actual fuel pressure ≥ 2.7 MPa (27.5 kg/cm<sup>2</sup>, 392 psi).</li></ul> | <ul style="list-style-type: none"><li>• Fuel system</li><li>• Leakage in fuel line</li><li>• High pressure fuel pump</li><li>• Low pressure fuel pump</li><li>• Damage in lifter</li></ul> |

### DTC CONFIRMATION PROCEDURE

#### 1. CHECK FUEL LEAKAGE

1. Turn ignition switch ON.
2. Visually check the piping between low pressure fuel pump and fuel injectors for fuel leakage.
3. Start the engine.
4. Visually check the piping between low pressure fuel pump and fuel injectors for fuel leakage.

#### Is inspection result normal?

- YES >> GO TO 2.  
NO >> Repair or replace error-detected parts.

#### 2. PRECONDITIONING

If DTC CONFIRMATION PROCEDURE has been previously conducted, always perform the following procedure before conducting the next test.

1. Turn ignition switch OFF and wait at least 10 seconds.
2. Turn ignition switch ON.
3. Turn ignition switch OFF and wait at least 10 seconds.

#### TESTING CONDITION:

- Before performing the following procedure, confirm that battery voltage is 11 V or more at idle.
- Before performing the following procedure, check that the fuel tank is 1/8 full of fuel.

>> GO TO 3.

#### 3. PERFORM DTC CONFIRMATION PROCEDURE-1

##### Ⓜ WITH CONSULT

1. Turn ignition switch ON.
2. Select "COOLAN TEMP/S" in "DATA MONITOR" mode of "ENGNE" using CONSULT.
3. Check the following condition;

**COOLAN TEMP/S** : 5 – 40°C (41 – 104°F)

##### Ⓜ WITH GST

# P0087 FRP CONTROL SYSTEM

[VK56VD FOR USA AND CANADA]

## < DTC/CIRCUIT DIAGNOSIS >

Follow the above steps for "WITH CONSULT".

Is the condition satisfied?

- YES >> GO TO 4.
- NO >> 1. Satisfy the condition.  
2. Retry from step 1.

### 4.PERFORM DTC CONFIRMATION PROCEDURE-2

 WITH CONSULT

1. Start the engine and let it idle for 10 seconds.
2. Check 1st trip DTC.

 WITH GST

Follow the above steps for "WITH CONSULT".

Is 1st trip DTC detected?

- YES >> Proceed to [EC-1189, "Diagnosis Procedure"](#).
- NO >> GO TO 5.

### 5.PERFORM DTC CONFIRMATION PROCEDURE-3

 WITH CONSULT

1. Select "COOLAN TEMP/S" in "DATA MONITOR" mode of "ENGINE" using CONSULT.
2. Maintain the following condition for 10 seconds or more at idle.

|                      |                               |
|----------------------|-------------------------------|
| <b>COOLAN TEMP/S</b> | <b>: 70°C (104°F) or more</b> |
|----------------------|-------------------------------|

3. Check 1st trip DTC.

 WITH GST

Follow the above steps for "WITH CONSULT".

Is 1st trip DTC detected?

- YES >> Proceed to [EC-1189, "Diagnosis Procedure"](#).
- NO >> INSPECTION END.

## Diagnosis Procedure

INFOID:000000007768693

### 1.BLEED THE FUEL LINE

1. Start the engine, and let the engine run at idle at least for 10 minutes.
2. Perform DTC confirmation procedure of DTC P0087.

Is 1st trip DTC detected?

- YES >> GO TO 2.
- NO >> GO TO 6.

### 2.CHECK LOW FUEL PRESSURE

 WITH CONSULT

1. Start the engine.
2. Check "L/FUEL PRES SEN V" in "DATA MONITOR" mode of "ECM" using CONSULT.

| Monitor item      | Condition                         | Value (Approx.) |
|-------------------|-----------------------------------|-----------------|
| L/FUEL PRES SEN V | Engine speed: idle                | 3,000 –3,300 mV |
|                   | Engine speed: 3,000 rpm (no load) |                 |

 WITHOUT CONSULT

1. Start the engine.
2. Check low fuel pressure sensor signal voltage.

# P0087 FRP CONTROL SYSTEM

< DTC/CIRCUIT DIAGNOSIS >

[VK56VD FOR USA AND CANADA]

| +         |          | -      | Condition                         | Value (Approx.) |
|-----------|----------|--------|-----------------------------------|-----------------|
| Connector | Terminal |        |                                   |                 |
| F39       | 2        | Ground | Engine speed: idle                | 3.0 –3.3 V      |
|           |          |        | Engine speed: 3,000 rpm (no load) |                 |

Is inspection result normal?

YES >> GO TO 3.

NO >> Check low fuel pressure system. Refer to [EC-1531, "Diagnosis Procedure"](#).

## 3.CHECK LOW PRESSURE FUEL LINE FOR INTERNAL LEAKAGE

WITH CONSULT

1. Turn ignition switch OFF.
2. Turn ignition switch ON.
3. Select "L/FUEL PRES SEN" in "DATA MONITOR" of "ECM" with CONSULT.
4. Check the following value 30 minutes after turning the ignition switch ON.

**L/FUEL PRES SEN : More than 0.20 MPa**

WITHOUT CONSULT

1. Turn ignition switch OFF.
2. Connect fuel pressure gauge. Refer to [EC-1127, "Work Procedure"](#).
3. Turn ignition switch ON.
4. Check the following value 30 minutes after turning the ignition switch ON.

**Low fuel pressure : 206 kPa (2.2 kgf/cm<sup>2</sup>, 30 psi) or more**

Is inspection result normal?

YES >> GO TO 4.

NO >> Replace low pressure fuel pump. Refer to [FL-6, "Removal and Installation"](#).

## 4.CHECK HIGH PRESSURE FUEL PUMP

Check high pressure fuel pump. Refer to [EC-1191, "Component Inspection \(High Pressure Fuel Pump\)"](#).

Is inspection result normal?

YES >> GO TO 5.

NO >> Repair or replace the error-detected parts.

## 5.CHECK LIFTER

Check lifter. Refer to [EM-193, "Removal and Installation"](#).

Does the lifter top surface have scratches and/or dents?

YES >> Replace the error-detected parts.

NO >> Check intermittent incident. Refer to [GI-44, "Intermittent Incident"](#).

## 6.CHECK LOW PRESSURE FUEL LINE FOR INTERNAL LEAKAGE

WITH CONSULT

1. Turn ignition switch OFF.
2. Turn ignition switch ON.
3. Select "L/FUEL PRES SEN" in "DATA MONITOR" mode of "ECM" using CONSULT.
4. Check the following value 30 minutes after turning the ignition switch ON.

**L/FUEL PRES SEN : More than 0.20 MPa**

WITHOUT CONSULT

1. Turn ignition switch OFF.
2. Connect fuel pressure gauge. Refer to [EC-1127, "Work Procedure"](#).
3. Turn ignition switch ON.
4. Check the following value 30 minutes after turning the ignition switch ON.

# P0087 FRP CONTROL SYSTEM

< DTC/CIRCUIT DIAGNOSIS >

[VK56VD FOR USA AND CANADA]

**Low fuel pressure : 206 kPa (2.2 kgf/cm<sup>2</sup>, 30 psi) or more**

Is inspection result normal?

YES >> Check intermittent incident. Refer to [GI-44, "Intermittent Incident"](#).

NO >> Replace low pressure fuel pump. Refer to [FL-6, "Removal and Installation"](#).

## Component Inspection (High Pressure Fuel Pump)

INFOID:000000007768694

### 1. CHECK HIGH PRESSURE FUEL PUMP-1

1. Turn ignition switch OFF.
2. Disconnect high pressure fuel pump harness connector.
3. Check the resistance between high pressure fuel pump terminals.

| +      -                         |   | Condition                             | Resistance (Approx.) |
|----------------------------------|---|---------------------------------------|----------------------|
| High pressure fuel pump Terminal |   |                                       |                      |
| 1                                | 2 | Temperature °C (°F) 20 – 30 (68 - 86) | 9 - 11 Ω             |

Is the inspection result normal?

YES >> GO TO 2.

NO >> Replace high pressure fuel pump. Refer to [EM-193, "Removal and Installation"](#).

### 2. CHECK HIGH PRESSURE FUEL PUMP-2

 WITH CONSULT

1. Reconnect high pressure fuel pump harness connector.
2. Start the engine.
3. Check "FUEL PRES SEN V" in "DATA MONITOR" mode of "ECM" using CONSULT.

| Monitor item    | Condition   | Voltage (Approx.) |
|-----------------|---|-------------------|
| FUEL PRES SEN V | Engine speed: idle  | 820 – 1,220 mV    |
|                 | Engine speed: Revving engine from idle to 4,000 rpm quickly | 820 – 3,060 mV    |

 WITHOUT CONSULT

1. Reconnect high pressure fuel pump harness connector.
2. Start the engine.
3. Check FRP sensor signal voltage.

| ECM       |          |    | Condition   | Value (Approx.) |
|-----------|----------|----|---|-----------------|
| Connector | +        | -  |   |                 |
|           | Terminal |    |   |                 |
| F110      | 31       | 40 | Engine speed: idle  | 0.82 – 1.22 V   |
|           |          |    | Engine speed: Revving engine from idle to 4,000 rpm quickly | 0.82 – 3.06 V   |

YES >> INSPECTION END

NO >> Replace high pressure fuel pump. Refer to [EM-193, "Removal and Installation"](#).

# P0088 FRP CONTROL SYSTEM

< DTC/CIRCUIT DIAGNOSIS >

[VK56VD FOR USA AND CANADA]

## P0088 FRP CONTROL SYSTEM

### DTC Logic

INFOID:000000007768695

### DTC DETECTION LOGIC

#### NOTE:

If DTC P0088 is displayed with DTC P0090, first perform the trouble diagnosis for DTC P0090.

| DTC No. | Trouble diagnosis name<br>(Trouble diagnosis content) | DTC detecting condition  | Possible cause  |
|---------|---|--|---|
| P0088   | HIGH FUEL PRES<br>(High fuel pressure too high)       | <ul style="list-style-type: none"><li>Fuel rail pressure remains at more than 16.5 MPa (168.3 kg/cm<sup>2</sup>, 2392.5 psi) for 1 second or more during engine idle condition after cold start [water temperature 5°C (41°F) - 40°C (104°F)].</li><li>The following condition continues for 5 seconds or more after engine start (regardless of water temperature):<br/>Actual fuel pressure – Target fuel pressure ≥ 2.7 MPa (27.5 kg/cm<sup>2</sup>, 392 psi)</li></ul> | <ul style="list-style-type: none"><li>Harness or connector<br/>(The high pressure fuel pump circuit is open or shorted)</li><li>High pressure fuel pump</li></ul> |

### DTC CONFIRMATION PROCEDURE

#### 1. PRECONDITIONING

If DTC CONFIRMATION PROCEDURE has been previously conducted, always perform the following procedure before conducting the next test.

- Turn ignition switch OFF and wait at least 10 seconds.
- Turn ignition switch ON.
- Turn ignition switch OFF and wait at least 10 seconds.

#### TESTING CONDITION:

- Before performing the following procedure, confirm that battery voltage is 11 V or more at idle.
- Before performing the following procedure, check that the fuel tank is 1/8 full of fuel.

>> GO TO 2.

#### 2. PERFORM DTC CONFIRMATION PROCEDURE-1

- Warm up the engine to the normal operating temperature and keep the engine speed at idle for 10 seconds.

#### NOTE:

Warm up the engine until "COOLAN TEMP/S" on "DATA MONITOR" mode of "ENGINE" using CONSULT reaches at least 70°C (158°F).

- Check 1st trip DTC.

Is 1st trip DTC detected?

YES >> Proceed to [EC-1195. "Diagnosis Procedure"](#).

NO >> GO TO 3.

#### 3. PERFORM DTC CONFIRMATION PROCEDURE-2

- Cool the engine until the engine coolant temperature reaches 60°C (140°F) or less.
- Start the engine and wait at least 40 seconds.
- Check 1st trip DTC.

Is 1st trip DTC detected?

YES >> Proceed to [EC-1195. "Diagnosis Procedure"](#).

NO >> INSPECTION END

### Diagnosis Procedure

INFOID:000000007768696

#### 1. CHECK LOW FUEL PRESSURE



# P0088 FRP CONTROL SYSTEM

< DTC/CIRCUIT DIAGNOSIS >

[VK56VD FOR USA AND CANADA]

**④ WITH CONSULT**

1. Start the engine.
2. Check "L/FUEL PRES SEN V" in "DATA MONITOR" mode of "ECM" using CONSULT.

| Monitor item      | Condition                         | Value (Approx.) |
|-------------------|-----------------------------------|-----------------|
| L/FUEL PRES SEN V | Engine speed: idle                | 3,000 –3,300 mV |
|                   | Engine speed: 3,000 rpm (no load) |                 |

**⊗ WITHOUT CONSULT**

1. Start the engine.
2. Check low fuel pressure sensor signal voltage.

| +                        |           | -      | Condition                         | Value (Approx.) |
|--------------------------|-----------|--------|-----------------------------------|-----------------|
| Low fuel pressure sensor | Connector |        |                                   |                 |
|                          | Terminal  | Ground | Engine speed: idle                | 3.0 –3.3 V      |
| F39                      | 2         |        | Engine speed: 3,000 rpm (no load) |                 |

Is inspection result normal?

YES >> GO TO 2.

NO >> Check low fuel pressure system. Refer to [EC-1531, "Diagnosis Procedure"](#).

## 2.CHECK HIGH PRESSURE FUEL PUMP

Check high pressure fuel pump. Refer to [EC-1193, "Component Inspection \(High Pressure Fuel Pump\)"](#).

Is inspection result normal?

YES >> GO TO 3.

NO >> Replace error-detected parts.

## 3.CHECK FUEL LEAKAGE

1. Start the engine.
2. Visually check that the fuel pump, fuel rail, and fuel piping have no fuel leakage.

Is inspection result normal?

YES >> Check that the fuel system has no breakage, bend, and crush. Refer to [FL-4, "Inspection"](#).

NO >> Replace or replace the error-detected parts.

## Component Inspection (High Pressure Fuel Pump)

INFOID:000000007768697

### 1.CHECK HIGH PRESSURE FUEL PUMP-1

1. Turn ignition switch OFF.
2. Disconnect high pressure fuel pump harness connector.
3. Check the resistance between high pressure fuel pump terminals.

| +                       |          | -                   |                   | Condition | Resistance (Approx.) |
|-------------------------|----------|---------------------|-------------------|-----------|----------------------|
| High pressure fuel pump | Terminal | 1                   | 2                 |           |                      |
|                         |          | Temperature °C (°F) | 20 – 30 (68 - 86) | 9 - 11 Ω  |                      |

Is the inspection result normal?

YES >> GO TO 2.

NO >> Replace high pressure fuel pump. Refer to [EM-193, "Removal and Installation"](#).

### 2.CHECK HIGH PRESSURE FUEL PUMP-2

**④ WITH CONSULT**

1. Reconnect high pressure fuel pump harness connector.
2. Start the engine.

# P0088 FRP CONTROL SYSTEM

< DTC/CIRCUIT DIAGNOSIS >

[VK56VD FOR USA AND CANADA]

3. Check "FUEL PRES SEN V" in "DATA MONITOR" mode of "ECM" using CONSULT.

| Monitor item    | Condition   | Value (Approx.) |
|-----------------|---|-----------------|
| FUEL PRES SEN V | Engine speed: idle  | 820 – 1,220 mV  |
|                 | Engine speed: Revving engine from idle to 4,000 rpm quickly | 820 – 3,060 mV  |

⊗ WITHOUT CONSULT

1. Reconnect high pressure fuel pump harness connector.
2. Start the engine.
3. Check FRP sensor signal voltage.

| ECM       |          |    | Condition   | Value (Approx.) |
|-----------|----------|----|---|-----------------|
| Connector | +        | -  |   |                 |
| F110      | Terminal |    | Engine speed: idle  | 0.82 – 1.22 V   |
|           | 31       | 40 | Engine speed: Revving engine from idle to 4,000 rpm quickly | 0.82 – 3.06 V   |

Is the inspection result normal?

YES >> INSPECTION END

NO >> Replace high pressure fuel pump. Refer to [EM-193. "Removal and Installation"](#).

# P0090 HIGH PRESSURE FUEL PUMP

< DTC/CIRCUIT DIAGNOSIS >

[VK56VD FOR USA AND CANADA]

## P0090 HIGH PRESSURE FUEL PUMP

### DTC Logic

INFOID:000000007768698

### DTC DETECTION LOGIC

#### NOTE:

- If DTC P0090 is displayed with DTC P1197, first perform the trouble diagnosis for DTC P1197.
- DTC P0090 may be displayed when running out of gas.

| DTC No. | Trouble diagnosis name<br>(Trouble diagnosis content) | DTC detecting condition  | Possible cause  |
|---------|---|--|---|
| P0090   | FUEL PUMP<br>(High pressure fuel pump circuit)        | <ul style="list-style-type: none"><li>• Fuel rail pressure remains at 1.5 MPa (15.3 kg/cm<sup>2</sup>, 217.5 psi) or less for 3 seconds or more during engine rev.</li><li>• Fuel rail pressure remains at 18.5 MPa (188.7 kg/cm<sup>2</sup>, 2682.5 psi) or more for 0.3 seconds or more during engine rev.</li></ul> | <ul style="list-style-type: none"><li>• Harness or connectors<br/>(The fuel pump circuit is open or shorted.)</li><li>• High pressure fuel pump</li></ul> |

### DTC CONFIRMATION PROCEDURE

#### 1. PRECONDITIONING

If DTC CONFIRMATION PROCEDURE has been previously conducted, always perform the following procedure before conducting the next test.

1. Turn ignition switch OFF and wait at least 10 seconds.
2. Turn ignition switch ON.
3. Turn ignition switch OFF and wait at least 10 seconds.

#### TESTING CONDITION:

- Before performing the following procedure, confirm that battery voltage is 11 V or more at idle.
- Before performing the following procedure, check that the fuel tank is 1/8 full of fuel.

>> GO TO 2.

#### 2. PERFORM DTC CONFIRMATION PROCEDURE-I

##### WITH CONSULT

1. Start engine.
2. Select "COOLAN TEMP/S" in "DATA MONITOR" mode of "ENGNE" using CONSULT.
3. Maintain the following condition for 5 seconds or more at idle.

**COOLAN TEMP/S : 70°C (104°F) or more**

4. Check 1st trip DTC.

##### WITH GST

Follow the above steps for "WITH CONSULT".

#### Is 1st trip DTC detected?

- YES >> Proceed to [EC-1195. "Diagnosis Procedure"](#).  
NO >> INSPECTION END

### Diagnosis Procedure

INFOID:000000007768699

#### 1. CHECK HIGH PRESSURE FUEL PUMP CIRCUIT

1. Turn ignition switch ON.
2. Disconnect ECM harness connector and high pressure fuel pump harness connector.
3. Check the continuity between ECM harness connector and high pressure fuel pump harness connector.

# P0090 HIGH PRESSURE FUEL PUMP

< DTC/CIRCUIT DIAGNOSIS >

[VK56VD FOR USA AND CANADA]

| +         |          | -                       |          | Value<br>(Approx.) |
|-----------|----------|-------------------------|----------|--------------------|
| ECM       |          | High pressure fuel pump |          |                    |
| Connector | Terminal | Connector               | Terminal |                    |
| F111      | 110      | F4                      | 2        | Existed            |
|           | 105      |                         | 1        |                    |

4. Also check harness for short to ground and to power.

Is inspection result normal?

YES >> GO TO 2.

NO >> Repair or replace the error-detected parts.

## 2.CHECK HIGH PRESSURE FUEL PUMP

Check high pressure fuel pump. Refer to [EC-1196, "Component Inspection \(High Pressure Fuel Pump\)"](#).

Is inspection result normal?

YES >> Check intermittent incident. Refer to [GI-44, "Intermittent Incident"](#).

NO >> Replace the error-detected parts.

## Component Inspection (High Pressure Fuel Pump)

INFOID:000000007768700

### 1.CHECK HIGH PRESSURE FUEL PUMP-1

1. Turn ignition switch OFF.
2. Disconnect high pressure fuel pump harness connector.
3. Check the resistance between high pressure fuel pump terminals.

| +                       |   | -                   |                   | Condition | Resistance<br>(Approx.) |
|-------------------------|---|---------------------|-------------------|-----------|-------------------------|
| High pressure fuel pump |   |                     |                   |           |                         |
| Terminal                |   |                     |                   |           |                         |
| 1                       | 2 | Temperature °C (°F) | 20 – 30 (68 - 86) | 9 - 11 Ω  |                         |

Is the inspection result normal?

YES >> GO TO 2.

NO >> Replace high pressure fuel pump. Refer to [EM-193, "Removal and Installation"](#).

### 2.CHECK HIGH PRESSURE FUEL PUMP-2

#### WITH CONSULT

1. Reconnect high pressure fuel pump harness connector.
2. Start the engine.
3. Check "FUEL PRES SEN" in "DATA MONITOR" mode of "ECM" using CONSULT.

| Monitor item    | Condition   | Value<br>(Approx.) |
|-----------------|---|--------------------|
| FUEL PRES SEN V | Engine speed: idle  | 820 – 1,220 mV     |
|                 | Engine speed: Revving engine from idle to 4,000 rpm quickly | 820 – 3,060 mV     |

#### WITHOUT CONSULT

1. Reconnect high pressure fuel pump harness connector.
2. Start the engine.
3. Check FRP sensor signal voltage.

# P0090 HIGH PRESSURE FUEL PUMP

< DTC/CIRCUIT DIAGNOSIS >

[VK56VD FOR USA AND CANADA]

| ECM       |          |    | Condition   | Value<br>(Approx.) |
|-----------|----------|----|---|--------------------|
| Connector | +        | -  |   |                    |
|           | Terminal |    |   |                    |
| F110      | 31       | 40 | Engine speed: idle  | 0.82 – 1.22 V      |
|           |          |    | Engine speed: Revving engine from idle to 4,000 rpm quickly | 0.82 – 3.06 V      |

Is the inspection result normal?

YES >> INSPECTION END

NO >> Replace high pressure fuel pump. Refer to [EM-193, "Removal and Installation"](#).

A

EC

C

D

E

F

G

H

I

J

K

L

M

N

O

P

# P0102, P0103, P010C, P010D MAF SENSOR

< DTC/CIRCUIT DIAGNOSIS >

[VK56VD FOR USA AND CANADA]

## P0102, P0103, P010C, P010D MAF SENSOR

### DTC Logic

INFOID:000000007187485

### DTC DETECTION LOGIC

| DTC No. | Trouble diagnosis name<br>(Trouble diagnosis content)                       | DTC detecting condition  | Possible cause  |
|---------|---|--|---|
| P0102   | MAF SEN/CIRCUIT-B1<br>[Mass air flow sensor (bank 1)<br>circuit low input]  | An excessively low voltage from the sensor<br>is sent to ECM.  | <ul style="list-style-type: none"><li>• Harness or connectors<br/>(The mass air flow sensor (bank 1) circuit is open or shorted.)</li><li>• Intake air leaks</li><li>• Mass air flow sensor</li></ul> |
| P0103   | MAF SEN/CIRCUIT-B1<br>[Mass air flow sensor (bank 1)<br>circuit high input] | An excessively high voltage from the sensor<br>is sent to ECM. | <ul style="list-style-type: none"><li>• Harness or connectors<br/>(The mass air flow sensor (bank 1) circuit is open or shorted.)</li><li>• Mass air flow sensor</li></ul>                            |
| P010C   | MAF SEN/CIRCUIT-B2<br>[Mass air flow sensor (bank 2)<br>circuit low input]  | An excessively low voltage from the sensor<br>is sent to ECM.  | <ul style="list-style-type: none"><li>• Harness or connectors<br/>(The mass air flow sensor (bank 2) circuit is open or shorted.)</li><li>• Intake air leaks</li><li>• Mass air flow sensor</li></ul> |
| P010D   | MAF SEN/CIRCUIT-B2<br>[Mass air flow sensor (bank 2)<br>circuit high input] | An excessively high voltage from the sensor<br>is sent to ECM. | <ul style="list-style-type: none"><li>• Harness or connectors<br/>(The mass air flow sensor (bank 2) circuit is open or shorted.)</li><li>• Mass air flow sensor</li></ul>                            |

### DTC CONFIRMATION PROCEDURE

#### 1. PRECONDITIONING

If DTC Confirmation Procedure has been previously conducted, always perform the following procedure before conducting the next test.

1. Turn ignition switch OFF and wait at least 10 seconds.
2. Turn ignition switch ON.
3. Turn ignition switch OFF and wait at least 10 seconds.

#### Which DTC is detected?

P0102, P010C >> GO TO 2.

P0103, P010D >> GO TO 3.

#### 2. PERFORM DTC CONFIRMATION PROCEDURE FOR DTC P0102 AND P010C

1. Start engine and wait at least 5 seconds.
2. Check DTC.

#### Is DTC detected?

YES >> Proceed to [EC-1199, "Diagnosis Procedure"](#).

NO >> INSPECTION END

#### 3. PERFORM DTC CONFIRMATION PROCEDURE FOR DTC P0103 AND P010D-I

1. Turn ignition switch ON and wait at least 5 seconds.
2. Check DTC.

#### Is DTC detected?

YES >> Proceed to [EC-1199, "Diagnosis Procedure"](#).

NO >> GO TO 4.

#### 4. PERFORM DTC CONFIRMATION PROCEDURE FOR DTC P0103 AND P010D-II

1. Start engine and wait at least 5 seconds.
2. Check DTC.

#### Is DTC detected?

YES >> Proceed to [EC-1199, "Diagnosis Procedure"](#).

# P0102, P0103, P010C, P010D MAF SENSOR

[VK56VD FOR USA AND CANADA]

< DTC/CIRCUIT DIAGNOSIS >

NO >> INSPECTION END

## Diagnosis Procedure

INFOID:000000007187486

### 1.INSPECTION START

Confirm the detected DTC.

Which DTC is detected?

P0102, P010C>>GO TO 2.

P0103, P010D>>GO TO 3.

### 2.CHECK INTAKE SYSTEM

Check the following for connection.

- Air duct
- Vacuum hoses
- Intake air passage between air duct to intake manifold

Is the inspection result normal?

YES >> GO TO 3.

NO >> Reconnect the parts.

### 3.CHECK MASS AIR FLOW SENSOR POWER SUPPLY CIRCUIT

1. Disconnect mass air flow (MAF) sensor harness connector.
2. Turn ignition switch ON.
3. Check the voltage between MAF sensor harness connector and ground.

| DTC          | MAF sensor |           |          | Ground | Voltage         |
|--------------|------------|-----------|----------|--------|-----------------|
|              | Bank       | Connector | Terminal |        |                 |
| P0102, P0103 | 1          | F86       | 5        | Ground | Battery voltage |
| P010C, P010D | 2          | F85       | 5        |        |                 |

Is the inspection result normal?

YES >> GO TO 5.

NO >> GO TO 4.

### 4.DETECT MALFUNCTIONING PART

Check the following.

- Harness for open or short between mass air flow sensor and ECM
- Harness for open or short between mass air flow sensor and IPDM E/R
- Loose or poor connection for each connector and harness

>> Repair open circuit, short to ground or short to power in harness or connectors.

### 5.CHECK MAF SENSOR GROUND CIRCUIT FOR OPEN AND SHORT

1. Turn ignition switch OFF.
2. Disconnect ECM harness connector.
3. Check the continuity between MAF sensor harness connector and ECM harness connector.

| DTC          | MAF sensor |           |          | ECM       |          | Continuity |
|--------------|------------|-----------|----------|-----------|----------|------------|
|              | Bank       | Connector | Terminal | Connector | Terminal |            |
| P0102, P0103 | 1          | F86       | 4        | F110      | 25       | Existed    |
| P010C, P010D | 2          | F85       | 4        |           | 30       |            |

4. Also check harness for short to ground and short to power.

Is the inspection result normal?

YES >> GO TO 6.

NO >> Repair open circuit, short to ground or short to power in harness or connectors.

### 6.CHECK MAF SENSOR INPUT SIGNAL CIRCUIT FOR OPEN AND SHORT

# P0102, P0103, P010C, P010D MAF SENSOR

< DTC/CIRCUIT DIAGNOSIS >

[VK56VD FOR USA AND CANADA]

1. Check the continuity between MAF sensor harness connector and ECM harness connector.

| DTC          | MAF sensor |           |          | ECM       |          | Continuity |
|--------------|------------|-----------|----------|-----------|----------|------------|
|              | Bank       | Connector | Terminal | Connector | Terminal |            |
| P0102, P0103 | 1          | F86       | 3        | F110      | 22       | Existed    |
| P010C, P010D | 2          | F85       | 3        |           | 24       |            |

2. Also check harness for short to ground and short to power.

Is the inspection result normal?

YES >> GO TO 7.

NO >> Repair open circuit, short to ground or short to power in harness or connectors.

## 7. CHECK MASS AIR FLOW SENSOR

Refer to [EC-1200, "Component Inspection \(MAF Sensor\)"](#).

Is the inspection result normal?

YES >> GO TO 8.

NO >> Replace malfunctioning mass air flow sensor. Refer to [EM-178, "Exploded View"](#).

## 8. CHECK INTERMITTENT INCIDENT

Refer to [GI-44, "Intermittent Incident"](#).

>> INSPECTION END

## Component Inspection (MAF Sensor)

INFOID:000000007187487

### 1. CHECK MASS AIR FLOW SENSOR-I

#### Ⓜ WITH CONSULT

1. Turn ignition switch OFF.
2. Reconnect all harness connectors disconnected.
3. Start engine and warm it up to normal operating temperature.
4. Connect CONSULT and select "DATA MONITOR" mode.
5. Select "MAS A/F SE-B1" and "MAS A/F SE-B2", and check the indication.

| Monitor item                   | Condition  | Indication (V)              |
|--------------------------------|--|-----------------------------|
| MAS A/F SE-B1<br>MAS A/F SE-B2 | Ignition switch ON (Engine stopped.)                             | Approx. 0.4                 |
|                                | Idle (Engine is warmed-up to normal operating temperature.)      | 0.95 - 1.35                 |
|                                | 2,500 rpm (Engine is warmed-up to normal operating temperature.) | 1.3 - 1.7                   |
|                                | Idle to about 4,000 rpm  | 0.95 - 1.35 to Approx. 2.4* |

\*: Check for linear voltage rise in response to engine being increased to about 4,000 rpm.

#### Ⓧ WITHOUT CONSULT

1. Turn ignition switch OFF.
2. Reconnect all harness connectors disconnected.
3. Start engine and warm it up to normal operating temperature.
4. Check the voltage between ECM harness connector terminals under the following conditions.



# P0102, P0103, P010C, P010D MAF SENSOR

< DTC/CIRCUIT DIAGNOSIS >

[VK56VD FOR USA AND CANADA]

| ECM       |                                       | Condition | Voltage (V)  |  |                             |
|-----------|---------------------------------------|-----------|--|--|-----------------------------|
| Connector | Terminal                              |           |  |  |                             |
| F110      | 22<br>[MAF sensor (bank 1)<br>signal] | 25        | Ignition switch ON (Engine stopped.)                             | Approx. 0.4  |                             |
|           |                                       | 30        | 25   | Idle (Engine is warmed-up to normal operating temperature.)      | 0.95 - 1.35                 |
|           |                                       |           | 25   | 2,500 rpm (Engine is warmed-up to normal operating temperature.) | 1.3 - 1.7                   |
|           |                                       |           | 25   | Idle to about 4,000 rpm  | 0.95 - 1.35 to Approx. 2.4* |
|           | 24<br>[MAF sensor (bank 2)<br>signal] |           | 30   | Ignition switch ON (Engine stopped.)                             | Approx. 0.4                 |
|           |                                       | 30        | Idle (Engine is warmed-up to normal operating temperature.)      | 0.95 - 1.35  |                             |
|           |                                       | 30        | 2,500 rpm (Engine is warmed-up to normal operating temperature.) | 1.3 - 1.7  |                             |
|           |                                       | 30        | Idle to about 4,000 rpm  | 0.95 - 1.35 to Approx. 2.4*                                      |                             |

\*: Check for linear voltage rise in response to engine being increased to about 4,000 rpm.

## Is the inspection result normal?

YES >> INSPECTION END

NO >> GO TO 2.

## 2.CHECK FOR THE CAUSE OF UNEVEN AIR FLOW THROUGH MASS AIR FLOW SENSOR

- Turn ignition switch OFF.
- Check for the cause of uneven air flow through mass air flow sensor. Refer to the following.
  - Crushed air ducts
  - Malfunctioning seal of air cleaner element
  - Uneven dirt of air cleaner element
  - Improper specification of intake air system parts

## Is the inspection result normal?

YES >> GO TO 4.

NO >> GO TO 3.

## 3.CHECK MASS AIR FLOW SENSOR-II

### Ⓜ WITH CONSULT

- Repair or replace malfunctioning part.
- Start engine and warm it up to normal operating temperature.
- Connect CONSULT and select "DATA MONITOR" mode.
- Select "MAS A/F SE-B1" and "MAS A/F SE-B2", and check the indication.

| Monitor item                   | Condition  | Indication (V)              |
|--------------------------------|--|-----------------------------|
| MAS A/F SE-B1<br>MAS A/F SE-B2 | Ignition switch ON (Engine stopped.)                             | Approx. 0.4                 |
|                                | Idle (Engine is warmed-up to normal operating temperature.)      | 0.95 - 1.35                 |
|                                | 2,500 rpm (Engine is warmed-up to normal operating temperature.) | 1.3 - 1.7                   |
|                                | Idle to about 4,000 rpm  | 0.95 - 1.35 to Approx. 2.4* |

\*: Check for linear voltage rise in response to engine being increased to about 4,000 rpm.

### Ⓧ WITHOUT CONSULT

- Repair or replace malfunctioning part.
- Start engine and warm it up to normal operating temperature.
- Check the voltage between ECM harness connector terminals under the following conditions.

# P0102, P0103, P010C, P010D MAF SENSOR

< DTC/CIRCUIT DIAGNOSIS >

[VK56VD FOR USA AND CANADA]

| ECM       |                                    | Condition | Voltage (V)  |                             |
|-----------|------------------------------------|-----------|--|-----------------------------|
| Connector | + Terminal                         |           |  | - Terminal                  |
| F110      | 22<br>[MAF sensor (bank 1) signal] | 25        | Ignition switch ON (Engine stopped.)                             | Approx. 0.4                 |
|           |                                    |           | Idle (Engine is warmed-up to normal operating temperature.)      | 0.95 - 1.35                 |
|           |                                    |           | 2,500 rpm (Engine is warmed-up to normal operating temperature.) | 1.3 - 1.7                   |
|           |                                    |           | Idle to about 4,000 rpm  | 0.95 - 1.35 to Approx. 2.4* |
|           | 24<br>[MAF sensor (bank 2) signal] | 30        | Ignition switch ON (Engine stopped.)                             | Approx. 0.4                 |
|           |                                    |           | Idle (Engine is warmed-up to normal operating temperature.)      | 0.95 - 1.35                 |
|           |                                    |           | 2,500 rpm (Engine is warmed-up to normal operating temperature.) | 1.3 - 1.7                   |
|           |                                    |           | Idle to about 4,000 rpm  | 0.95 - 1.35 to Approx. 2.4* |

\*: Check for linear voltage rise in response to engine being increased to about 4,000 rpm.

## Is the inspection result normal?

YES >> INSPECTION END

NO >> GO TO 4.

## 4. CHECK MASS AIR FLOW SENSOR-III

### ④ WITH CONSULT

1. Turn ignition switch OFF.
2. Disconnect mass air flow sensor harness connector and reconnect it again.
3. Start engine and warm it up to normal operating temperature.
4. Connect CONSULT and select "DATA MONITOR" mode.
5. Select "MAS A/F SE-B1" and "MAS A/F SE-B2", and check the indication.

| Monitor item                   | Condition  | Indication (V)              |
|--------------------------------|--|-----------------------------|
| MAS A/F SE-B1<br>MAS A/F SE-B2 | Ignition switch ON (Engine stopped.)                             | Approx. 0.4                 |
|                                | Idle (Engine is warmed-up to normal operating temperature.)      | 0.95 - 1.35                 |
|                                | 2,500 rpm (Engine is warmed-up to normal operating temperature.) | 1.3 - 1.7                   |
|                                | Idle to about 4,000 rpm  | 0.95 - 1.35 to Approx. 2.4* |

\*: Check for linear voltage rise in response to engine being increased to about 4,000 rpm.

### ⊗ WITHOUT CONSULT

1. Turn ignition switch OFF.
2. Disconnect mass air flow sensor harness connector and reconnect it again.
3. Start engine and warm it up to normal operating temperature.
4. Check the voltage between ECM harness connector terminals under the following conditions.

# P0102, P0103, P010C, P010D MAF SENSOR

< DTC/CIRCUIT DIAGNOSIS >

[VK56VD FOR USA AND CANADA]

| ECM       |                                       |          | Condition  | Voltage (V)                 |
|-----------|---------------------------------------|----------|--|-----------------------------|
| Connector | +                                     | -        |  |                             |
|           | Terminal                              | Terminal |  |                             |
| F110      | 22<br>[MAF sensor (bank 1)<br>signal] | 25       | Ignition switch ON (Engine stopped.)                             | Approx. 0.4                 |
|           |                                       |          | Idle (Engine is warmed-up to normal operating temperature.)      | 0.95 - 1.35                 |
|           |                                       |          | 2,500 rpm (Engine is warmed-up to normal operating temperature.) | 1.3 - 1.7                   |
|           |                                       |          | Idle to about 4,000 rpm  | 0.95 - 1.35 to Approx. 2.4* |
|           | 24<br>[MAF sensor (bank 2)<br>signal] | 30       | Ignition switch ON (Engine stopped.)                             | Approx. 0.4                 |
|           |                                       |          | Idle (Engine is warmed-up to normal operating temperature.)      | 0.95 - 1.35                 |
|           |                                       |          | 2,500 rpm (Engine is warmed-up to normal operating temperature.) | 1.3 - 1.7                   |
|           |                                       |          | Idle to about 4,000 rpm  | 0.95 - 1.35 to Approx. 2.4* |

\*: Check for linear voltage rise in response to engine being increased to about 4,000 rpm.

## Is the inspection result normal?

YES >> INSPECTION END

NO >> Clean or replace malfunctioning mass air flow sensor. Refer to [EM-184, "Removal and Installation"](#).

# P0106 MANIFOLD ABSOLUTE PRESSURE SENSOR

< DTC/CIRCUIT DIAGNOSIS >

[VK56VD FOR USA AND CANADA]

## P0106 MANIFOLD ABSOLUTE PRESSURE SENSOR

### DTC Logic

INFOID:000000007187488

### DTC DETECTION LOGIC

#### NOTE:

If DTC P0106 is displayed with other DTC, first perform the trouble diagnosis for other DTC.

| DTC No. | Trouble diagnosis name<br>(Trouble diagnosis content)                                 | DTC detecting condition  | Possible cause   |
|---------|---|--|--|
| P0106   | ABSL PRES SEN/CIRC<br>[Manifold absolute pressure (MAP)<br>circuit range/performance] | A difference exceeding the specified value develops between a value transmitted from the manifold absolute pressure (MAP) sensor to ECM and an estimated intake pressure of intake manifold calculated by ECM. | <ul style="list-style-type: none"><li>• Harness or connectors (The manifold absolute pressure (MAP) sensor circuit is open or shorted.)</li><li>• manifold absolute pressure (MAP) sensor</li><li>• Intake air leaks</li></ul> |

### DTC CONFIRMATION PROCEDURE

#### 1. PRECONDITIONING

If DTC Confirmation Procedure has been previously conducted, always perform the following procedure before conducting the next test.

1. Turn ignition switch OFF and wait at least 10 seconds.
2. Turn ignition switch ON.
3. Turn ignition switch OFF and wait at least 10 seconds.

If engine will not start or stops soon, wait at least 10 seconds with engine stopped (Ignition switch ON) instead of running engine at idle speed.

>> GO TO 2.

#### 2. PERFORM DTC CONFIRMATION PROCEDURE

##### Ⓜ WITH CONSULT

1. Turn ignition switch ON and select "DATA MONITOR" mode with CONSULT.
2. Start engine and warm it up to normal operating temperature.
3. Accelerate the vehicle from 0 to 88 km/h (0 to 55 MPH) under the following conditions:

#### CAUTION:

**Always drive at a safe speed.**

#### NOTE:

- Accelerate with the accelerator pedal kept constant.
- The acceleration at engine speed 2,000 and 3,000 rpm allows easy diagnoses.

|                |             |
|----------------|-------------|
| ACCEL SEN 1    | 1.4 – 2.0 V |
| Selector lever | D position  |

4. Check 1st trip DTC.

##### ⓧ WITHOUT CONSULT

1. Start engine and warm it up to normal operating temperature.
2. Drive the vehicle under the following conditions.
3. With selector lever in D position, accelerate the vehicle from 0 to 88 km/h (0 to 55 MPH) under the following conditions:

#### CAUTION:

**Always drive at a safe speed.**

#### NOTE:

- Accelerate with the accelerator pedal kept constant.
- The acceleration at engine speed 2,000 and 3,000 rpm allows easy diagnoses.

# P0106 MANIFOLD ABSOLUTE PRESSURE SENSOR

< DTC/CIRCUIT DIAGNOSIS >

[VK56VD FOR USA AND CANADA]

| Accelerator pedal position sensor 1 |          | Ground | Voltage (V) |
|-------------------------------------|----------|--------|-------------|
| Connector                           | Terminal |        |             |
| M9 (Without ICC)                    | 3        | Ground | 1.4 – 2.0   |
| M153 (With ICC)                     |          |        |             |

4. Check 1st trip DTC.

Is 1st trip DTC detected?

- YES >> Proceed to [EC-1205. "Diagnosis Procedure"](#).  
NO >> INSPECTION END

## Diagnosis Procedure

INFOID:000000007187489

### 1. CHECK INTAKE SYSTEM

Check the following for connection.

- Air duct
- Vacuum hoses
- Intake air passage between air duct and intake manifold.

Is the inspection result normal?

- YES >> GO TO 2.  
NO >> Repair or replace malfunctioning part.

### 2. CHECK MANIFOLD ABSOLUTE PRESSURE (MAP) SENSOR POWER SUPPLY CIRCUIT FOR OPEN AND SHORT

1. Disconnect manifold absolute pressure (MAP) sensor harness connector.
2. Turn ignition switch ON.
3. Check the voltage between manifold absolute pressure (MAP) sensor harness connector and ground.

| Manifold absolute pressure (MAP) sensor |          | Ground | Voltage (V) |
|---|----------|--------|-------------|
| Connector                               | Terminal |        |             |
| F19                                     | 1        | Ground | Approx. 5   |

Is the inspection result normal?

- YES >> GO TO 3.  
NO >> Repair open circuit, short to ground or short to power in harness or connectors.

### 3. CHECK MANIFOLD ABSOLUTE PRESSURE (MAP) SENSOR GROUND CIRCUIT FOR OPEN AND SHORT

1. Turn ignition switch OFF.
2. Disconnect ECM harness connector.
3. Check the continuity between manifold absolute pressure (MAP) sensor harness connector and ECM harness connector.

| Manifold absolute pressure (MAP) sensor |          | ECM       |          | Continuity |
|---|----------|-----------|----------|------------|
| Connector                               | Terminal | Connector | Terminal |            |
| F19                                     | 3        | F111      | 70       | Existed    |

4. Also check harness for short to ground and power.

Is the inspection result normal?

- YES >> GO TO 4.  
NO >> Repair open circuit, short to ground or short to power in harness or connectors.

### 4. CHECK MANIFOLD ABSOLUTE PRESSURE (MAP) SENSOR INPUT SIGNAL CIRCUIT FOR OPEN AND SHORT

1. Check the continuity between manifold absolute pressure (MAP) sensor harness connector and ECM harness connector.

# P0106 MANIFOLD ABSOLUTE PRESSURE SENSOR

< DTC/CIRCUIT DIAGNOSIS >

[VK56VD FOR USA AND CANADA]

| Manifold absolute pressure (MAP) sensor |          | ECM       |          | Continuity |
|---|----------|-----------|----------|------------|
| Connector                               | Terminal | Connector | Terminal |            |
| F19                                     | 2        | F111      | 67       | Existed    |

2. Also check harness for short to ground and power.

Is the inspection result normal?

YES >> GO TO 5.

NO >> Repair open circuit, short to ground or short to power in harness or connectors.

## 5. CHECK MANIFOLD ABSOLUTE PRESSURE (MAP) SENSOR

Refer to [EC-1206. "Component Inspection \(MAP Sensor\)"](#).

Is the inspection result normal?

YES >> GO TO 6.

NO >> Replace manifold absolute pressure (MAP) sensor. Refer to [EM-190. "Exploded View"](#).

## 6. CHECK INTERMITTENT INCIDENT

Refer to [GI-44. "Intermittent Incident"](#).

>> INSPECTION END

## Component Inspection (MAP Sensor)

INFOID:000000007187490

### 1. CHECK MAP SENSOR-I

1. Turn ignition switch OFF.
2. Start engine and warm it up to normal operating temperature.
3. Turn ignition switch OFF, wait at least 5 seconds and then turn ON.
4. Check the voltage between ECM harness connector terminals as follows.

| ECM       |          |           |          |
|-----------|----------|-----------|----------|
| +         |          | -         |          |
| Connector | Terminal | Connector | Terminal |
| F111      | 67       | F111      | 70       |

#### NOTE:

- To avoid the influence of intake manifold vacuum, check the voltage 1 or more minutes past after engine is stopped.
- Because the sensor is absolute pressure sensor, output value may differ depending on atmospheric pressure and altitude.

5. Measure the atmospheric pressure.

#### NOTE:

As the atmospheric pressure described on the synoptic chart is the value at sea level, compensate the pressure with the following chart.

| Altitude (m) | Compensated pressure (hPa) |
|--------------|----------------------------|
| 0            | 0                          |
| 200          | -24                        |
| 400          | -47                        |
| 600          | -70                        |
| 800          | -92                        |
| 1000         | -114                       |
| 1500         | -168                       |
| 2000         | -218                       |

6. Check the manifold absolute pressure sensor value corresponding to the atmospheric pressure.

# P0106 MANIFOLD ABSOLUTE PRESSURE SENSOR

< DTC/CIRCUIT DIAGNOSIS >

[VK56VD FOR USA AND CANADA]

| Atmospheric pressure (hPa) | Voltage (V) |
|----------------------------|-------------|
| 800                        | 3.1 – 3.7   |
| 850                        | 3.3 – 3.9   |
| 900                        | 3.5 – 4.1   |
| 950                        | 3.8 – 4.3   |
| 1000                       | 4.0 – 4.6   |
| 1050                       | 4.2 – 4.8   |

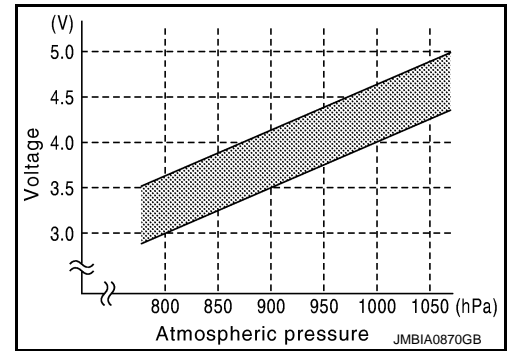

Is the inspection result normal?

YES >> GO TO 2.

NO >> Replace MAP sensor. Refer to [EM-190, "Exploded View"](#).

## 2. CHECK MAP SENSOR-II

1. Start engine and let it idle.
2. Check intake manifold vacuum.
3. Check the voltage between ECM harness connector terminals as per the following.

| ECM       |          |           |          |
|-----------|----------|-----------|----------|
| +         |          | -         |          |
| Connector | Terminal | Connector | Terminal |
| F111      | 67       | F111      | 70       |

4. Confirm the difference of the voltage when engine is stopped and at idling is within the values shown in the following chart.

| Intake manifold vacuum [kPA (mmHg)] | Voltage difference (V) |
|-------------------------------------|------------------------|
| -40 (-300)                          | 1.5 – 2.0              |
| -53.3 (-400)                        | 2.0 – 2.6              |
| -66.7 (-500)                        | 2.6 – 3.2              |
| -80 (-600)                          | 3.2 – 3.8              |

Is the inspection result normal?

YES >> INSPECTION END

NO >> Replace MAP sensor. Refer to [EM-190, "Exploded View"](#).

A  
EC  
C  
D  
E  
F  
G  
H  
I  
J  
K  
L  
M  
N  
O  
P

# P010A MANIFOLD ABSOLUTE PRESSURE SENSOR

< DTC/CIRCUIT DIAGNOSIS >

[VK56VD FOR USA AND CANADA]

## P010A MANIFOLD ABSOLUTE PRESSURE SENSOR

### DTC Logic

INFOID:000000007187491

### DTC DETECTION LOGIC

#### NOTE:

If DTC P010A is displayed with DTC P0643, first perform the trouble diagnosis for DTC P0643.  
Refer to [EC-1389, "DTC Logic"](#).

| DTC No. | Trouble diagnosis name<br>(Trouble diagnosis content)                      | DTC detecting condition  | Possible cause  |
|---------|--|--|---|
| P010A   | ABSL PRES SEN/CIRC<br>[Manifold absolute pressure (MAP)<br>sensor circuit] | <ul style="list-style-type: none"><li>An excessively low voltage from the sensor is sent to ECM.</li><li>An excessively high voltage from the sensor is sent to ECM.</li></ul> | <ul style="list-style-type: none"><li>Harness or connectors (Manifold absolute pressure sensor circuit is shorted.)</li><li>Manifold absolute pressure sensor</li></ul> |

### DTC CONFIRMATION PROCEDURE

#### 1. PRECONDITIONING

If DTC Confirmation Procedure has been previously conducted, always perform the following procedure before conducting the next test.

- Turn ignition switch OFF and wait at least 10 seconds.
- Turn ignition switch ON.
- Turn ignition switch OFF and wait at least 10 seconds.

>> GO TO 2.

#### 2. PERFORM DTC CONFIRMATION PROCEDURE

- Start engine and let it idle for 10 seconds.
- Check DTC.

#### Is DTC detected?

YES >> Proceed to [EC-1208, "Diagnosis Procedure"](#).

NO >> INSPECTION END

### Diagnosis Procedure

INFOID:000000007187492

#### 1. CHECK MANIFOLD ABSOLUTE PRESSURE (MAP) SENSOR POWER SUPPLY CIRCUIT-I

- Disconnect manifold absolute pressure (MAP) sensor harness connector.
- Turn ignition switch ON.
- Check the voltage manifold absolute pressure (MAP) sensor harness connector and ground.

| Manifold absolute pressure (MAP) sensor |          | Ground | Voltage (V) |
|---|----------|--------|-------------|
| Connector                               | Terminal |        |             |
| F19                                     | 1        | Ground | Approx. 5   |

#### Is the inspection result normal?

YES >> GO TO 2.

NO >> Repair open circuit, short to ground in harness or connectors.

#### 2. CHECK MANIFOLD ABSOLUTE PRESSURE (MAP) SENSOR GROUND CIRCUIT FOR OPEN AND SHORT

- Turn ignition switch OFF.
- Disconnect ECM harness connector.
- Check the continuity between manifold absolute pressure (MAP) sensor harness connector and ECM harness connector.



# P010A MANIFOLD ABSOLUTE PRESSURE SENSOR

< DTC/CIRCUIT DIAGNOSIS >

[VK56VD FOR USA AND CANADA]

| Manifold absolute pressure (MAP) sensor |          | ECM       |          | Continuity |
|---|----------|-----------|----------|------------|
| Connector                               | Terminal | Connector | Terminal |            |
| F19                                     | 3        | F111      | 70       | Existed    |

4. Also check harness for short to ground and short to power.

Is the inspection result normal?

YES >> GO TO 3.

NO >> Repair open circuit, short to power in harness or connectors.

## 3.CHECK MANIFOLD ABSOLUTE PRESSURE (MAP) SENSOR INPUT SIGNAL CIRCUIT FOR OPEN AND SHORT

1. Check the continuity between manifold absolute pressure (MAP) sensor harness connector and ECM harness connector.

| Manifold absolute pressure (MAP) sensor |          | ECM       |          | Continuity |
|---|----------|-----------|----------|------------|
| Connector                               | Terminal | Connector | Terminal |            |
| F19                                     | 2        | F111      | 67       | Existed    |

2. Also check harness for short to ground and short to power.

Is the inspection result normal?

YES >> GO TO 4.

NO >> Repair open circuit, short to ground or short to power in harness or connectors.

## 4.CHECK MANIFOLD ABSOLUTE PRESSURE (MAP) SENSOR

Refer to [EC-1209, "Component Inspection \(MAP Sensor\)"](#).

Is the inspection result normal?

YES >> GO TO 5.

NO >> Replace manifold absolute pressure (MAP) sensor. Refer to [EM-190, "Exploded View"](#).

## 5.CHECK INTERMITTENT INCIDENT

Refer to [GI-44, "Intermittent Incident"](#).

>> INSPECTION END

## Component Inspection (MAP Sensor)

INFOID:000000007187493

### 1.CHECK MAP SENSOR-I

1. Turn ignition switch OFF.
2. Start engine and warm it up to normal operating temperature.
3. Turn ignition switch OFF, wait at least 5 seconds and then turn ON.
4. Check the voltage between ECM harness connector terminals as follows.

| ECM       |          |           |          |
|-----------|----------|-----------|----------|
| +         |          | -         |          |
| Connector | Terminal | Connector | Terminal |
| F111      | 67       | F111      | 70       |

#### NOTE:

- To avoid the influence of intake manifold vacuum, check the voltage 1 or more minutes past after engine is stopped.
- Because the sensor is absolute pressure sensor, output value may differ depending on atmospheric pressure and altitude.

5. Measure the atmospheric pressure.

#### NOTE:

As the atmospheric pressure described on the synoptic chart is the value at sea level, compensate the pressure with the following chart.

# P010A MANIFOLD ABSOLUTE PRESSURE SENSOR

< DTC/CIRCUIT DIAGNOSIS >

[VK56VD FOR USA AND CANADA]

| Altitude (m) | Compensated pressure (hPa) |
|--------------|----------------------------|
| 0            | 0                          |
| 200          | -24                        |
| 400          | -47                        |
| 600          | -70                        |
| 800          | -92                        |
| 1000         | -114                       |
| 1500         | -168                       |
| 2000         | -218                       |

6. Check the manifold absolute pressure sensor value corresponding to the atmospheric pressure.

| Atmospheric pressure (hPa) | Voltage (V) |
|----------------------------|-------------|
| 800                        | 3.1 – 3.7   |
| 850                        | 3.3 – 3.9   |
| 900                        | 3.5 – 4.1   |
| 950                        | 3.8 – 4.3   |
| 1000                       | 4.0 – 4.6   |
| 1050                       | 4.2 – 4.8   |

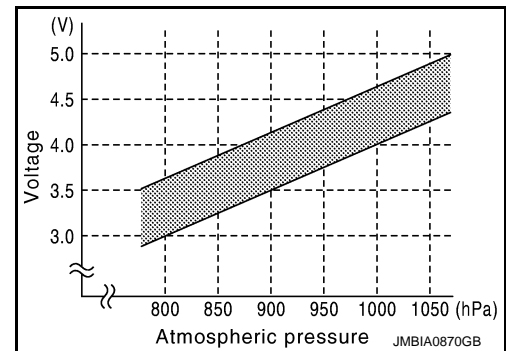

Is the inspection result normal?

YES >> GO TO 2.

NO >> Replace MAP sensor. Refer to [EM-190. "Exploded View"](#).

## 2. CHECK MAP SENSOR-II

1. Start engine and let it idle.
2. Check intake manifold vacuum.
3. Check the voltage between ECM harness connector terminals as per the following.

| ECM       |          |           |          |
|-----------|----------|-----------|----------|
| +         |          | -         |          |
| Connector | Terminal | Connector | Terminal |
| F111      | 67       | F111      | 70       |

4. Confirm the difference of the voltage when engine is stopped and at idling is within the values shown in the following chart.

| Intake manifold vacuum [kPA (mmHg)] | Voltage difference (V) |
|-------------------------------------|------------------------|
| -40 (-300)                          | 1.5 – 2.0              |
| -53.3 (-400)                        | 2.0 – 2.6              |
| -66.7 (-500)                        | 2.6 – 3.2              |
| -80 (-600)                          | 3.2 – 3.8              |

Is the inspection result normal?

YES >> INSPECTION END

NO >> Replace MAP sensor. Refer to [EM-190. "Exploded View"](#).

# P0111 IAT SENSOR

< DTC/CIRCUIT DIAGNOSIS >

[VK56VD FOR USA AND CANADA]

## P0111 IAT SENSOR

### DTC Logic

INFOID:000000007184890

### DTC DETECTION LOGIC

| DTC No. | Trouble diagnosis<br>(Trouble diagnosis content)   | DTC detecting condition  | Possible cause  |
|---------|--|--|---|
| P0111   | IAT SENSOR 1 B1<br>[Intake air temperature (IAT)<br>sensor circuit range/perfor-<br>mance] | The comparison result of signals transmitted to ECM from each temperature sensor (IAT sensor, ECT sensor, FTT sensor, and EOT sensor) shows that the voltage signal of the IAT sensor is higher/lower than that of other temperature sensors when the engine is started with its cold state. | <ul style="list-style-type: none"><li>• Harness or connectors<br/>(High or low resistance in the IAT sensor circuit)</li><li>• IAT sensor</li></ul> |

### DTC CONFIRMATION PROCEDURE

#### 1.INSPECTION START

##### Is it necessary to erase permanent DTC?

YES >> GO TO 3.

NO >> GO TO 2.

#### 2.PERFORM COMPONENT FUNCTION CHECK

Perform component function check. Refer to [EC-1212, "Component Function Check"](#).

##### **NOTE:**

Use the component function check to check the overall function of the IAT sensor circuit. During this check, a 1st trip DTC might not be confirmed.

##### Is the inspection result normal?

YES >> INSPECTION END

NO >> Proceed to [EC-1212, "Diagnosis Procedure"](#).

#### 3.PRECONDITIONING

If DTC CONFIRMATION PROCEDURE has been previously conducted, always perform the following procedure before conducting the next test.

1. Turn ignition switch OFF and wait at least 10 seconds.
2. Turn ignition switch ON.
3. Turn ignition switch OFF and wait at least 10 seconds.

##### **TESTING CONDITION:**

- Before performing the following procedure, do not add fuel.
- Before performing the following procedure, check that fuel level is between 1/4 and 4/4.
- Before performing the following procedure, confirm that battery voltage is 11 V or more at idle.

>> GO TO 4.

#### 4.PERFORM DTC CONFIRMATION PROCEDURE

1. Start engine and let it idle for 60 minutes.
2. Move the vehicle to a cool place.

##### **NOTE:**

Cool the vehicle in an environment of ambient air temperature between  $-10^{\circ}\text{C}$  ( $14^{\circ}\text{F}$ ) and  $35^{\circ}\text{C}$  ( $95^{\circ}\text{F}$ ).

3. Turn ignition switch OFF and soak the vehicle for 12 hours.

##### **CAUTION:**

**Never turn ignition switch ON during soaking.**

##### **NOTE:**

The vehicle must be cooled with the hood open.

4. Start engine and let it idle for 5 minutes or more.

##### **CAUTION:**

**Never turn ignition switch OFF during idling.**

# P0111 IAT SENSOR

[VK56VD FOR USA AND CANADA]

< DTC/CIRCUIT DIAGNOSIS >

5. Check 1st trip DTC.

Is 1st trip DTC detected?

- YES >> Proceed to [EC-1212, "Diagnosis Procedure"](#).
- NO >> INSPECTION END

## Component Function Check

INFOID:000000007184891

### 1. CHECK INTAKE AIR TEMPERATURE (IAT) SENSOR

1. Turn ignition switch OFF.
2. Disconnect mass air flow sensor (bank 1) harness connector.
3. Check resistance between mass air flow sensor (bank 1) terminals as follows.

| Terminals | Condition             | Resistance (kΩ)          |
|-----------|-----------------------|--------------------------|
| 1 and 2   | Temperature [°C (°F)] | 25 (77)<br>1.800 – 2.200 |

Is the inspection result normal?

- YES >> GO TO 2.
- NO >> Proceed to [EC-1212, "Diagnosis Procedure"](#).

### 2. CHECK INTERMITTENT INCIDENT

Refer to [GI-44, "Intermittent Incident"](#).

Is the inspection result normal?

- YES >> INSPECTION END
- NO >> Proceed to [EC-1212, "Diagnosis Procedure"](#).

## Diagnosis Procedure

INFOID:000000007184892

### 1. CHECK INTAKE AIR TEMPERATURE (IAT) SENSOR

Check intake air temperature sensor. Refer to [EC-1212, "Component Inspection"](#).

Is the inspection result normal?

- YES >> GO TO 2.
- NO >> Replace mass air flow sensor (with intake air temperature sensor) (bank 1). Refer to [EM-184, "Exploded View"](#).

### 2. CHECK INTERMITTENT INCIDENT

Refer to [GI-44, "Intermittent Incident"](#).

>> INSPECTION END

## Component Inspection

INFOID:000000007184893

### 1. CHECK INTAKE AIR TEMPERATURE (IAT) SENSOR

1. Turn ignition switch OFF.
2. Disconnect mass air flow sensor (bank 1) harness connector.
3. Check resistance between mass air flow sensor (bank 1) terminals as follows.

| Terminals | Condition             | Resistance (kΩ)          |
|-----------|-----------------------|--------------------------|
| 1 and 2   | Temperature [°C (°F)] | 25 (77)<br>1.800 – 2.200 |

Is the inspection result normal?

- YES >> INSPECTION END
- NO >> Replace mass air flow sensor (with intake air temperature sensor) (bank 1). Refer to [EM-184, "Exploded View"](#).

# P0112, P0113 IAT SENSOR

< DTC/CIRCUIT DIAGNOSIS >

[VK56VD FOR USA AND CANADA]

## P0112, P0113 IAT SENSOR

### DTC Logic

INFOID:000000007187494

### DTC DETECTION LOGIC

| DTC No. | Trouble diagnosis name<br>(Trouble diagnosis content)                    | DTC detecting condition                                     | Possible cause   |
|---------|--|---|--|
| P0112   | IAT SEN/CIRCUIT-B1<br>(Intake air temperature sensor circuit low input)  | An excessively low voltage from the sensor is sent to ECM.  | <ul style="list-style-type: none"> <li>• Harness or connectors<br/>(The intake air temperature sensor circuit is open or shorted.)</li> <li>• Intake air temperature sensor</li> </ul> |
| P0113   | IAT SEN/CIRCUIT-B1<br>(Intake air temperature sensor circuit high input) | An excessively high voltage from the sensor is sent to ECM. |  |

### DTC CONFIRMATION PROCEDURE

#### 1. PRECONDITIONING

If DTC Confirmation Procedure has been previously conducted, always perform the following procedure before conducting the next test.

1. Turn ignition switch OFF and wait at least 10 seconds.
2. Turn ignition switch ON.
3. Turn ignition switch OFF and wait at least 10 seconds.

>> GO TO 2.

#### 2. PERFORM DTC CONFIRMATION PROCEDURE

1. Turn ignition switch ON and wait at least 5 seconds.
2. Check 1st trip DTC.

Is 1st trip DTC detected?

- YES >> Proceed to [EC-1213, "Diagnosis Procedure"](#).  
 NO >> INSPECTION END

### Diagnosis Procedure

INFOID:000000007187495

#### 1. CHECK INTAKE AIR TEMPERATURE SENSOR POWER SUPPLY CIRCUIT

1. Disconnect mass air flow (MAF) sensor (bank 1) (intake air temperature sensor is built-in) harness connector.
2. Turn ignition switch ON.
3. Check the voltage between MAF sensor (bank 1) harness connector and ground.

| MAF sensor (bank 1) |          | Ground | Voltage (V) |
|---------------------|----------|--------|-------------|
| Connector           | Terminal |        |             |
| F86                 | 2        | Ground | Approx. 5   |

Is the inspection result normal?

- YES >> GO TO 2.  
 NO >> Repair open circuit, short to ground or short to power in harness or connectors.

#### 2. CHECK INTAKE AIR TEMPERATURE SENSOR GROUND CIRCUIT FOR OPEN AND SHORT

1. Turn ignition switch OFF.
2. Disconnect ECM harness connector.
3. Check the continuity between MAF sensor (bank 1) harness connector and ECM harness connector.

| MAF sensor (bank 1) |          | ECM       |          | Continuity |
|---------------------|----------|-----------|----------|------------|
| Connector           | Terminal | Connector | Terminal |            |
| F86                 | 1        | F110      | 25       | Existed    |

## P0112, P0113 IAT SENSOR

[VK56VD FOR USA AND CANADA]

< DTC/CIRCUIT DIAGNOSIS >

4. Also check harness for short to ground and short to power.

Is the inspection result normal?

YES >> GO TO 3.

NO >> Repair open circuit, short to ground or short to power in harness or connectors.

### 3. CHECK INTAKE AIR TEMPERATURE SENSOR

Refer to [EC-1214, "Component Inspection \(Intake Air Temperature Sensor\)"](#).

Is the inspection result normal?

YES >> GO TO 4.

NO >> Replace mass air flow sensor (bank 1) (with intake air temperature sensor). Refer to [EM-184, "Exploded View"](#).

### 4. CHECK INTERMITTENT INCIDENT

Refer to [GI-44, "Intermittent Incident"](#).

>> INSPECTION END

## Component Inspection (Intake Air Temperature Sensor)

INFOID:000000007187496

### 1. CHECK INTAKE AIR TEMPERATURE SENSOR

1. Turn ignition switch OFF.
2. Disconnect mass air flow sensor (bank 1) harness connector.
3. Check resistance between mass air flow sensor (bank 1) terminals as per the following.

| Terminals | Condition             | Resistance (kΩ)     |
|-----------|-----------------------|---------------------|
| 1 and 2   | Temperature [°C (°F)] | 25 (77) 1.94 - 2.06 |

Is the inspection result normal?

YES >> INSPECTION END

NO >> Replace mass air flow sensor (bank 1) (with intake air temperature sensor). Refer to [EM-184, "Exploded View"](#).

# P0116 ECT SENSOR

[VK56VD FOR USA AND CANADA]

< DTC/CIRCUIT DIAGNOSIS >

## P0116 ECT SENSOR

### DTC Logic

INFOID:000000007187497

### DTC DETECTION LOGIC

| DTC No. | Trouble diagnosis name<br>(Trouble diagnosis content)                               | DTC detecting condition  | Possible cause  |
|---------|---|--|---|
| P0116   | ECT SEN/CIRC<br>[Engine coolant temperature (ECT) sensor circuit range/performance] | The comparison result of signals transmitted to ECM from each temperature sensor (IAT sensor, ECT sensor, FTT sensor, and EOT sensor) shows that the voltage signal of the ECT sensor is higher/lower than that of other temperature sensors when the engine is started with its cold state. | <ul style="list-style-type: none"><li>• Harness or connectors (High or low resistance in the circuit)</li><li>• Engine coolant temperature sensor</li></ul> |

### DTC CONFIRMATION PROCEDURE

#### 1.INSPECTION START

Is it necessary to erase permanent DTC?

YES >> GO TO 3.

NO >> GO TO 2.

#### 2.PERFORM COMPONENT FUNCTION CHECK

Perform component function check. Refer to [EC-1216. "Component Function Check"](#).

**NOTE:**

Use the component function check to check the overall function of the ECT sensor circuit. During this check, a 1st trip DTC might not be confirmed.

Is the inspection result normal?

YES >> INSPECTION END

NO >> Proceed to [EC-1216. "Diagnosis Procedure"](#).

#### 3.PRECONDITIONING

If DTC CONFIRMATION PROCEDURE has been previously conducted, always perform the following procedure before conducting the next test.

1. Turn ignition switch OFF and wait at least 10 seconds.
2. Turn ignition switch ON.
3. Turn ignition switch OFF and wait at least 10 seconds.

**TEST CONDITION:**

- Before performing the following procedure, do not add fuel.
- Before performing the following procedure, check that fuel level is between 1/4 and 4/4.
- Before performing the following procedure, confirm that battery voltage is 11 V or more at idle.

>> GO TO 4.

#### 4.PERFORM DTC CONFIRMATION PROCEDURE

1. Start engine and let it idle for 60 minutes.
2. Move the vehicle to a cool place.

**NOTE:**

Cool the vehicle in an environment of ambient air temperature between -10°C (14°F) and 35°C (95°F).

3. Turn ignition switch OFF and soak the vehicle for 12 hours.

**CAUTION:**

**Never turn ignition switch ON during soaking.**

**NOTE:**

The vehicle must be cooled with the hood open.

4. Start engine and let it idle for 5 minutes or more.

**CAUTION:**

**Never turn ignition switch OFF during idling.**

5. Check 1st trip DTC.

# P0116 ECT SENSOR

[VK56VD FOR USA AND CANADA]

< DTC/CIRCUIT DIAGNOSIS >

Is 1st trip DTC detected?

- YES >> Proceed to [EC-1216, "Diagnosis Procedure"](#).
- NO >> INSPECTION END

## Component Function Check

INFOID:000000007202568

### 1.CHECK ENGINE COOLANT TEMPERATURE (ECT) SENSOR

1. Turn ignition switch OFF.
2. Disconnect ECT sensor harness connector.
3. Remove ECT sensor. Refer to [EM-264, "Exploded View"](#).
4. Check resistance between ECT sensor terminals by heating with hot water as shown in the figure.

| Terminals | Condition             |          | Resistance (kΩ) |
|-----------|-----------------------|----------|-----------------|
| 1 and 2   | Temperature [°C (°F)] | 20 (68)  | 2.1 - 2.9       |
|           |                       | 50 (122) | 0.68 - 1.00     |
|           |                       | 90 (194) | 0.236 - 0.260   |

Is the inspection result normal?

- YES >> GO TO 2.
- NO >> Proceed to [EC-1216, "Diagnosis Procedure"](#).

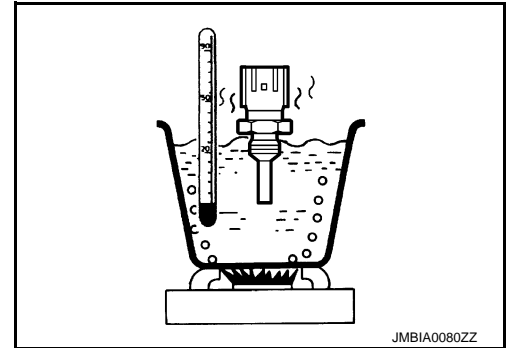

### 2.CHECK INTERMITTENT INCIDENT

Check intermittent incident. Refer to [GI-44, "Intermittent Incident"](#).

Is the inspection result normal?

- YES >> INSPECTION END
- NO >> Proceed to [EC-1216, "Diagnosis Procedure"](#).

## Diagnosis Procedure

INFOID:000000007187498

### 1.CHECK ENGINE COOLANT TEMPERATURE (ECT) SENSOR

Check ECT sensor. Refer to [EC-1216, "Component Inspection \(Engine Coolant Temperature Sensor\)"](#).

Is the inspection result normal?

- OK >> GO TO 2.
- NG >> Replace ECT sensor. Refer to [EM-264, "Exploded View"](#).

### 2.CHECK INTERMITTENT INCIDENT

Check intermittent incident. Refer to [GI-44, "Intermittent Incident"](#).

>> **INSPECTION END**

## Component Inspection (Engine Coolant Temperature Sensor)

INFOID:000000007187499

### 1.CHECK ENGINE COOLANT TEMPERATURE (ECT) SENSOR

1. Turn ignition switch OFF.
2. Disconnect ECT sensor harness connector.
3. Remove ECT sensor. Refer to [EM-264, "Exploded View"](#).



# P0116 ECT SENSOR

[VK56VD FOR USA AND CANADA]

## < DTC/CIRCUIT DIAGNOSIS >

4. Check resistance between ECT sensor terminals by heating with hot water as shown in the figure.

| Terminals | Condition             | Resistance (kΩ) |               |
|-----------|-----------------------|-----------------|---------------|
| 1 and 2   | Temperature [°C (°F)] | 20 (68)         | 2.1 - 2.9     |
|           |                       | 50 (122)        | 0.68 - 1.00   |
|           |                       | 90 (194)        | 0.236 - 0.260 |

Is the inspection result normal?

YES >> INSPECTION END

NO >> Replace ECT sensor. Refer to [EM-264](#), "[Exploded View](#)".

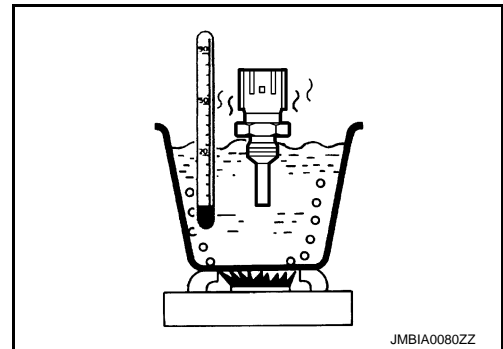

A

EC

C

D

E

F

G

H

I

J

K

L

M

N

O

P

# P0117, P0118 ECT SENSOR

< DTC/CIRCUIT DIAGNOSIS >

[VK56VD FOR USA AND CANADA]

## P0117, P0118 ECT SENSOR

### DTC Logic

INFOID:000000007187500

### DTC DETECTION LOGIC

| DTC No. | Trouble diagnosis name<br>(Trouble diagnosis content)                  | DTC detecting condition                                     | Possible cause  |
|---------|--|---|---|
| P0117   | ECT SEN/CIRC<br>(Engine coolant temperature sensor circuit low input)  | An excessively low voltage from the sensor is sent to ECM.  | <ul style="list-style-type: none"><li>• Harness or connectors<br/>(The engine coolant temperature sensor circuit is open or shorted.)</li><li>• Engine coolant temperature sensor</li></ul> |
| P0118   | ECT SEN/CIRC<br>(Engine coolant temperature sensor circuit high input) | An excessively high voltage from the sensor is sent to ECM. |   |

### DTC CONFIRMATION PROCEDURE

#### 1. PRECONDITIONING

If DTC Confirmation Procedure has been previously conducted, always perform the following procedure before conducting the next test.

1. Turn ignition switch OFF and wait at least 10 seconds.
2. Turn ignition switch ON.
3. Turn ignition switch OFF and wait at least 10 seconds.

>> GO TO 2.

#### 2. PERFORM DTC CONFIRMATION PROCEDURE

1. Turn ignition switch ON and wait at least 5 seconds.
2. Check DTC.

Is DTC detected?

- YES >> Proceed to [EC-1218, "Diagnosis Procedure"](#).  
NO >> INSPECTION END

### Diagnosis Procedure

INFOID:000000007187501

#### 1. CHECK ENGINE COOLANT TEMPERATURE SENSOR POWER SUPPLY CIRCUIT

1. Disconnect engine coolant temperature (ECT) sensor harness connector.
2. Turn ignition switch ON.
3. Check the voltage between ECT sensor harness connector and ground.

| ECT sensor |          | Ground | Voltage (V) |
|------------|----------|--------|-------------|
| Connector  | Terminal |        |             |
| F17        | 1        | Ground | Approx. 5   |

Is the inspection result normal?

- YES >> GO TO 2.  
NO >> Repair open circuit, short to ground or short to power in harness or connectors.

#### 2. CHECK ECT SENSOR GROUND CIRCUIT FOR OPEN AND SHORT

1. Turn ignition switch OFF.
2. Disconnect ECM harness connector.
3. Check the continuity between ECT sensor harness connector and ECM harness connector.

| ECT sensor |          | ECM       |          | Continuity |
|------------|----------|-----------|----------|------------|
| Connector  | Terminal | Connector | Terminal |            |
| F17        | 2        | F110      | 40       | Existed    |

# P0117, P0118 ECT SENSOR

[VK56VD FOR USA AND CANADA]

## < DTC/CIRCUIT DIAGNOSIS >

4. Also check harness for short to ground and short to power.

Is the inspection result normal?

YES >> GO TO 3.

NO >> Repair open circuit, short to ground or short to power in harness or connectors.

### 3. CHECK ENGINE COOLANT TEMPERATURE SENSOR

Refer to [EC-1216, "Component Inspection \(Engine Coolant Temperature Sensor\)"](#).

Is the inspection result normal?

YES >> GO TO 4.

NO >> Replace engine coolant temperature sensor. Refer to [EM-264, "Exploded View"](#).

### 4. CHECK INTERMITTENT INCIDENT

Refer to [GI-44, "Intermittent Incident"](#).

>> INSPECTION END

## Component Inspection (Engine Coolant Temperature Sensor)

INFOID:000000007187502

### 1. CHECK ENGINE COOLANT TEMPERATURE (ECT) SENSOR

1. Turn ignition switch OFF.
2. Disconnect ECT sensor harness connector.
3. Remove ECT sensor. Refer to [EM-264, "Exploded View"](#).
4. Check resistance between ECT sensor terminals by heating with hot water as shown in the figure.

| Terminals | Condition                                   | Resistance (k $\Omega$ ) |               |
|-----------|---|--------------------------|---------------|
| 1 and 2   | Temperature [ $^{\circ}$ C ( $^{\circ}$ F)] | 20 (68)                  | 2.1 - 2.9     |
|           |   | 50 (122)                 | 0.68 - 1.00   |
|           |   | 90 (194)                 | 0.236 - 0.260 |

Is the inspection result normal?

YES >> INSPECTION END

NO >> Replace ECT sensor. Refer to [EM-264, "Exploded View"](#).

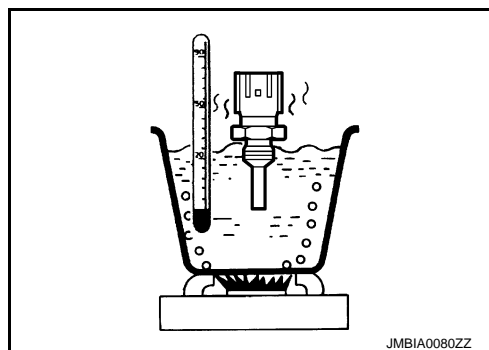

# P0122, P0123, P0227, P0228 TP SENSOR

< DTC/CIRCUIT DIAGNOSIS >

[VK56VD FOR USA AND CANADA]

## P0122, P0123, P0227, P0228 TP SENSOR

### DTC Logic

INFOID:000000007187503

### DTC DETECTION LOGIC

#### NOTE:

If DTC P0122, P0123, P0227 or P0228 is displayed with DTC P0643, first perform the trouble diagnosis for DTC P0643. Refer to [EC-1389, "DTC Logic"](#).

| DTC No. | Trouble diagnosis name<br>(Trouble diagnosis content)                           | DTC detecting condition  | Possible cause   |
|---------|---|--|--|
| P0122   | TP SEN 2/CIRC-B1<br>[Throttle position sensor 2<br>(bank 1) circuit low input]  | An excessively low voltage from the TP sensor 2 is sent to ECM.  | <ul style="list-style-type: none"><li>• Harness or connectors (TP sensor 2 circuit is open or shorted.)</li><li>• Electric throttle control actuator (TP sensor 2)</li></ul> |
| P0123   | TP SEN 2/CIRC-B1<br>[Throttle position sensor 2<br>(bank 1) circuit high input] | An excessively high voltage from the TP sensor 2 is sent to ECM. |  |
| P0227   | TP SEN 2/CIRC-B2<br>[Throttle position sensor 2<br>(bank 2) circuit low input]  | An excessively low voltage from the TP sensor 2 is sent to ECM.  |  |
| P0228   | TP SEN 2/CIRC-B2<br>[Throttle position sensor 2<br>(bank 2) circuit high input] | An excessively high voltage from the TP sensor 2 is sent to ECM. |  |

### DTC CONFIRMATION PROCEDURE

#### 1. PRECONDITIONING

1. Turn ignition switch OFF and wait at least 10 seconds.
2. Turn ignition switch ON.
3. Turn ignition switch OFF and wait at least 10 seconds.

#### TESTING CONDITION:

Before performing the following procedure, confirm that battery voltage is 8 V or more at idle.

>> GO TO 2.

#### 2. PERFORM DTC CONFIRMATION PROCEDURE

1. Start engine and let it idle for 1 second.
2. Check DTC.

#### Is DTC detected?

YES >> Proceed to [EC-1220, "Diagnosis Procedure"](#).

NO >> INSPECTION END

### Diagnosis Procedure

INFOID:000000007187504

#### 1. CHECK THROTTLE POSITION SENSOR 2 POWER SUPPLY CIRCUIT-I

1. Disconnect electric throttle control actuator harness connector.
2. Turn ignition switch ON.
3. Check the voltage between electric throttle control actuator harness connector and ground.

| DTC          | Electric throttle control actuator |           |          | Ground | Voltage (V) |
|--------------|------------------------------------|-----------|----------|--------|-------------|
|              | Bank                               | Connector | Terminal |        |             |
| P0122, P0123 | 1                                  | F66       | 2        | Ground | Approx. 5   |
| P0227, P0228 | 2                                  | F64       | 2        |        |             |

#### Is the inspection result normal?

YES >> GO TO 2.

NO >> Repair open circuit, short to ground or short to power in harness or connectors.

# P0122, P0123, P0227, P0228 TP SENSOR

< DTC/CIRCUIT DIAGNOSIS >

[VK56VD FOR USA AND CANADA]

## 2. CHECK THROTTLE POSITION SENSOR 2 GROUND CIRCUIT FOR OPEN AND SHORT

1. Turn ignition switch OFF.
2. Disconnect ECM harness connector.
3. Check the continuity between electric throttle control actuator harness connector and ECM harness connector.

| DTC          | Electric throttle control actuator |           |          | ECM       |          | Continuity |
|--------------|------------------------------------|-----------|----------|-----------|----------|------------|
|              | Bank                               | Connector | Terminal | Connector | Terminal |            |
| P0122, P0123 | 1                                  | F66       | 4        | F111      | 97       | Existed    |
| P0227, P0228 | 2                                  | F64       | 4        |           | 69       |            |

4. Also check harness for short to ground and short to power.

Is the inspection result normal?

YES >> GO TO 3.

NO >> Repair open circuit, short to ground or short to power in harness or connectors.

## 3. CHECK THROTTLE POSITION SENSOR 2 INPUT SIGNAL CIRCUIT FOR OPEN AND SHORT

1. Check the continuity between electric throttle control actuator harness connector and ECM harness connector.

| DTC          | Electric throttle control actuator |           |          | ECM       |          | Continuity |
|--------------|------------------------------------|-----------|----------|-----------|----------|------------|
|              | Bank                               | Connector | Terminal | Connector | Terminal |            |
| P0122, P0123 | 1                                  | F66       | 3        | F111      | 79       | Existed    |
| P0227, P0228 | 2                                  | F64       | 3        |           | 89       |            |

2. Also check harness for short to ground and short to power.

Is the inspection result normal?

YES >> GO TO 4.

NO >> Repair open circuit, short to ground or short to power in harness or connectors.

## 4. CHECK THROTTLE POSITION SENSOR

Refer to [EC-1221, "Component Inspection \(Throttle Position Sensor\)"](#).

Is the inspection result normal?

YES >> GO TO 6.

NO >> GO TO 5.

## 5. REPLACE ELECTRIC THROTTLE CONTROL ACTUATOR

Replace malfunctioning electric throttle control actuator. Refer to [EM-191, "Removal and Installation"](#).

>> INSPECTION END

## 6. CHECK INTERMITTENT INCIDENT

Refer to [GI-44, "Intermittent Incident"](#).

>> INSPECTION END

## Component Inspection (Throttle Position Sensor)

INFOID:000000007187505

### 1. CHECK THROTTLE POSITION SENSOR

1. Turn ignition switch OFF.
2. Reconnect all harness connectors disconnected.
3. Perform [EC-1121, "Work Procedure"](#).
4. Turn ignition switch ON.
5. Set selector lever position to D.
6. Check the voltage between ECM harness connector terminals under the following conditions.

# P0122, P0123, P0227, P0228 TP SENSOR

< DTC/CIRCUIT DIAGNOSIS >

[VK56VD FOR USA AND CANADA]

| Connector | ECM                          |          | Condition                          | Voltage (V)    |
|-----------|------------------------------|----------|------------------------------------|----------------|
|           | +                            | -        |                                    |                |
|           | Terminal                     | Terminal |                                    |                |
| F111      | 91<br>[TP sensor 1 (bank 1)] | 97       | Accelerator pedal: Fully released  | More than 0.36 |
|           |                              |          | Accelerator pedal: Fully depressed | Less than 4.75 |
|           | 71<br>[TP sensor 1 (bank 2)] | 69       | Accelerator pedal: Fully released  | More than 0.36 |
|           |                              |          | Accelerator pedal: Fully depressed | Less than 4.75 |
|           | 79<br>[TP sensor 2 (bank 1)] | 97       | Accelerator pedal: Fully released  | Less than 4.75 |
|           |                              |          | Accelerator pedal: Fully depressed | More than 0.36 |
|           | 89<br>[TP sensor 2 (bank 2)] | 69       | Accelerator pedal: Fully released  | Less than 4.75 |
|           |                              |          | Accelerator pedal: Fully depressed | More than 0.36 |

Is the inspection result normal?

YES >> INSPECTION END

NO >> GO TO 2.

## 2. REPLACE ELECTRIC THROTTLE CONTROL ACTUATOR

Replace malfunctioning electric throttle control actuator. Refer to [EM-191. "Removal and Installation"](#).

>> INSPECTION END

# P0125 ECT SENSOR

< DTC/CIRCUIT DIAGNOSIS >

[VK56VD FOR USA AND CANADA]

## P0125 ECT SENSOR

### DTC Logic

INFOID:000000007187506

### DTC DETECTION LOGIC

#### NOTE:

If DTC P0125 is displayed with P0117 or P0118, first perform the trouble diagnosis for DTC P0117, P0118. Refer to [EC-1218, "DTC Logic"](#).

| DTC No. | Trouble diagnosis name<br>(Trouble diagnosis content)                                | DTC detecting condition  | Possible cause  |
|---------|--|--|---|
| P0125   | ECT SENSOR<br>(Insufficient engine coolant temperature for closed loop fuel control) | <ul style="list-style-type: none"><li>• Voltage sent to ECM from the sensor is not practical, even when some time has passed after starting the engine.</li><li>• Engine coolant temperature is insufficient for closed loop fuel control.</li></ul> | <ul style="list-style-type: none"><li>• Harness or connectors (High resistance in the circuit)</li><li>• Engine coolant temperature sensor</li><li>• Thermostat</li></ul> |

### DTC CONFIRMATION PROCEDURE

#### 1. PRECONDITIONING

If DTC Confirmation Procedure has been previously conducted, always perform the following procedure before conducting the next test.

1. Turn ignition switch OFF and wait at least 10 seconds.
2. Turn ignition switch ON.
3. Turn ignition switch OFF and wait at least 10 seconds.

>> GO TO 2.

#### 2. CHECK ENGINE COOLANT TEMPERATURE SENSOR FUNCTION

##### WITH CONSULT

1. Turn ignition switch ON.
2. Select "DATA MONITOR" mode with CONSULT.
3. Check that "COOLAN TEMP/S" is above 10°C (50°F).

##### WITH GST

Follow the procedure "With CONSULT" above.

Is the temperature above 10°C (50°F)?

- YES >> INSPECTION END  
NO >> GO TO 3.

#### 3. PERFORM DTC CONFIRMATION PROCEDURE

##### WITH CONSULT

1. Start engine and run it for 65 minutes at idle speed.  
If "COOLAN TEMP/S" increases to more than 10°C (50°F) within 65 minutes, stop engine because the test result will be OK.

#### CAUTION:

**Never overheat engine.**

2. Check 1st trip DTC.

##### WITH GST

Follow the procedure "With CONSULT" above.

Is 1st trip DTC detected?

- YES >> [EC-1223, "Diagnosis Procedure"](#)  
NO >> INSPECTION END

### Diagnosis Procedure

INFOID:000000007187507

#### 1. CHECK ENGINE COOLANT TEMPERATURE SENSOR

Refer to [EC-1219, "Component Inspection \(Engine Coolant Temperature Sensor\)"](#).

Is the inspection result normal?

# P0125 ECT SENSOR

[VK56VD FOR USA AND CANADA]

## < DTC/CIRCUIT DIAGNOSIS >

YES >> GO TO 2.

NO >> Replace engine coolant temperature sensor. Refer to [EM-264, "Exploded View"](#).

## 2.CHECK THERMOSTAT OPERATION

When the engine is cold [lower than 70°C (158°F)] condition, grasp lower radiator hose and confirm that the engine coolant does not flow.

Is the inspection result normal?

YES >> GO TO 3.

NO >> Repair or replace thermostat. Refer to [CO-48, "Removal and Installation"](#).

## 3.CHECK INTERMITTENT INCIDENT

Refer to [GI-44, "Intermittent Incident"](#).

>> INSPECTION END

## Component Inspection (Engine Coolant Temperature Sensor)

INFOID:000000007187508

## 1.CHECK ENGINE COOLANT TEMPERATURE (ECT) SENSOR

1. Turn ignition switch OFF.
2. Disconnect ECT sensor harness connector.
3. Remove ECT sensor. Refer to [EM-264, "Exploded View"](#).
4. Check resistance between ECT sensor terminals by heating with hot water as shown in the figure.

| Terminals | Condition             | Resistance (kΩ) |               |
|-----------|-----------------------|-----------------|---------------|
| 1 and 2   | Temperature [°C (°F)] | 20 (68)         | 2.1 - 2.9     |
|           |                       | 50 (122)        | 0.68 - 1.00   |
|           |                       | 90 (194)        | 0.236 - 0.260 |

Is the inspection result normal?

YES >> INSPECTION END

NO >> Replace ECT sensor. Refer to [EM-264, "Exploded View"](#).

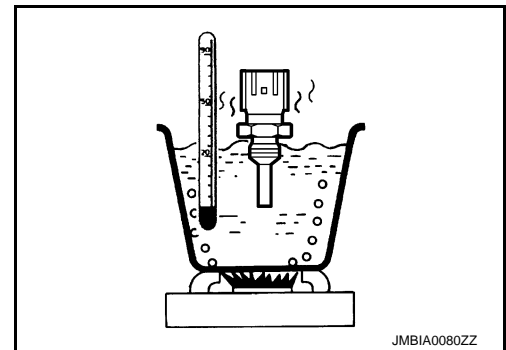



# P0127 IAT SENSOR

< DTC/CIRCUIT DIAGNOSIS >

[VK56VD FOR USA AND CANADA]

## P0127 IAT SENSOR

### DTC Logic

INFOID:000000007187509

### DTC DETECTION LOGIC

| DTC No. | Trouble diagnosis name<br>(Trouble diagnosis content) | DTC detecting condition   | Possible cause   |
|---------|---|---|--|
| P0127   | IAT SENSOR-B1<br>(Intake air temperature too high)    | Rationally incorrect voltage from the sensor is sent to ECM, compared with the voltage signal from engine coolant temperature sensor. | <ul style="list-style-type: none"><li>• Harness or connectors<br/>(The intake air temperature sensor circuit is open or shorted)</li><li>• Intake air temperature sensor</li></ul> |

### DTC CONFIRMATION PROCEDURE

#### 1. PRECONDITIONING

If DTC Confirmation Procedure has been previously conducted, always perform the following procedure before conducting the next test.

1. Turn ignition switch OFF and wait at least 10 seconds.
2. Turn ignition switch ON.
3. Turn ignition switch OFF and wait at least 10 seconds.

#### TESTING CONDITION:

**This test may be conducted with the drive wheels lifted in the shop or by driving the vehicle. If a road test is expected to be easier, it is unnecessary to lift the vehicle.**

>> GO TO 2.

#### 2. PERFORM DTC CONFIRMATION PROCEDURE

##### WITH CONSULT

1. Wait until engine coolant temperature is less than 96°C (205°F)
  - Turn ignition switch ON.
  - Select "DATA MONITOR" mode with CONSULT.
  - Check the engine coolant temperature.
  - If the engine coolant temperature is not less than 96°C (205°F), turn ignition switch OFF and cool down engine.

#### NOTE:

Perform the following steps before engine coolant temperature is above 96°C (205°F).

2. Turn ignition switch ON.
3. Select "DATA MONITOR" mode with CONSULT.
4. Start engine.
5. Hold vehicle speed at more than 70 km/h (43 MPH) for 100 consecutive seconds.

#### CAUTION:

**Always drive vehicle at a safe speed.**

6. Check 1st trip DTC.

##### WITH GST

Follow the procedure "With CONSULT" above.

Is 1st trip DTC detected?

- YES >> Proceed to [EC-1225. "Diagnosis Procedure"](#).  
NO >> INSPECTION END

### Diagnosis Procedure

INFOID:000000007187510

#### 1. CHECK INTAKE AIR TEMPERATURE SENSOR

Refer to [EC-1226. "Component Inspection \(Intake Air Temperature Sensor\)"](#).

Is the inspection result normal?

- YES >> GO TO 2.  
NO >> Replace mass air flow sensor (bank 1) (with intake air temperature sensor). Refer to [EM-184. "Exploded View"](#).

# P0127 IAT SENSOR

< DTC/CIRCUIT DIAGNOSIS >

[VK56VD FOR USA AND CANADA]

## 2. CHECK INTERMITTENT INCIDENT

Refer to [GI-44. "Intermittent Incident"](#).

>> INSPECTION END

## Component Inspection (Intake Air Temperature Sensor)

INFOID:000000007187511

### 1. CHECK INTAKE AIR TEMPERATURE SENSOR

1. Turn ignition switch OFF.
2. Disconnect mass air flow sensor (bank 1) harness connector.
3. Check resistance between mass air flow sensor (bank 1) terminals as per the following.

| Terminals | Condition                        | Resistance (kΩ) |
|-----------|----------------------------------|-----------------|
| 1 and 2   | Temperature [°C (°F)]<br>25 (77) | 1.94 - 2.06     |

Is the inspection result normal?

YES >> INSPECTION END

NO >> Replace mass air flow sensor (bank 1) (with intake air temperature sensor). Refer to [EM-184. "Exploded View"](#).

# P0128 THERMOSTAT FUNCTION

< DTC/CIRCUIT DIAGNOSIS >

[VK56VD FOR USA AND CANADA]

## P0128 THERMOSTAT FUNCTION

### DTC Logic

INFOID:000000007187512

### DTC DETECTION LOGIC

#### NOTE:

If DTC P0128 is displayed with DTC P0300, P0301, P0302, P0303, P0304, P0305, P0306, P0307 or P0308, first perform the trouble diagnosis for DTC P0300, P0301, P0302, P0303, P0304, P0305, P0306, P0307, P0308. Refer to [EC-1297. "DTC Logic"](#).

Engine coolant temperature has not risen enough to open the thermostat even though the engine has run long enough.

This is due to a leakage in the seal or the thermostat being stuck open.

| DTC No. | Trouble diagnosis name<br>(Trouble diagnosis content) | DTC detecting condition  | Possible cause  |
|---------|---|--|---|
| P0128   | THERMSTAT FNCTN<br>(Thermostat function)              | The engine coolant temperature does not reach to specified temperature even though the engine has run long enough. | <ul style="list-style-type: none"><li>• Thermostat</li><li>• Leakage from sealing portion of thermostat</li><li>• Engine coolant temperature sensor</li></ul> |

### DTC CONFIRMATION PROCEDURE

#### 1. PRECONDITIONING

If DTC Confirmation Procedure has been previously conducted, always perform the following procedure before conducting the next test.

1. Turn ignition switch OFF and wait at least 10 seconds.
2. Turn ignition switch ON.
3. Turn ignition switch OFF and wait at least 10 seconds.

#### TESTING CONDITION:

- For best results, perform at ambient temperature of  $-10^{\circ}\text{C}$  ( $14^{\circ}\text{F}$ ) or higher.
- For best results, perform at engine coolant temperature of  $-10^{\circ}\text{C}$  ( $14^{\circ}\text{F}$ ) to  $51^{\circ}\text{C}$  ( $124^{\circ}\text{F}$ ).
- Before performing the following procedure, do not add fuel.

>> GO TO 2.

#### 2. PERFORM DTC CONFIRMATION PROCEDURE

##### Ⓜ WITH CONSULT

1. Turn A/C switch OFF.
2. Turn blower fan switch OFF.
3. Turn ignition switch ON.
4. Select "COOLAN TEMP/S" in "DATA MONITOR" mode with CONSULT.
5. Check the indication of "COOLAN TEMP/S".  
If it is below  $51^{\circ}\text{C}$  ( $124^{\circ}\text{F}$ ), go to next step.  
If it is above  $51^{\circ}\text{C}$  ( $124^{\circ}\text{F}$ ), cool engine down to less than  $51^{\circ}\text{C}$  ( $124^{\circ}\text{F}$ ). Then go to next step.
6. Start engine and drive vehicle for 10 consecutive minutes under the following conditions.

|               |                            |
|---------------|----------------------------|
| Vehicle speed | More than 56 km/h (35 MPH) |
|---------------|----------------------------|

#### CAUTION:

Always drive vehicle at a safe speed.

#### NOTE:

If "COOLAN TEMP/S" increases to more than  $70^{\circ}\text{C}$  ( $158^{\circ}\text{F}$ ) within 10 minutes, turn ignition switch OFF because the test result will be OK.

7. Check 1st trip DTC.

##### Ⓜ WITH GST

Follow the procedure "With CONSULT" above.

#### Is 1st trip DTC detected?

- YES >> Proceed to [EC-1228. "Diagnosis Procedure"](#).  
NO >> INSPECTION END

# P0128 THERMOSTAT FUNCTION

[VK56VD FOR USA AND CANADA]

< DTC/CIRCUIT DIAGNOSIS >

INFOID:000000007187513

## Diagnosis Procedure

### 1. CHECK ENGINE COOLANT TEMPERATURE SENSOR

Refer to [EC-1228, "Component Inspection \(Engine Coolant Temperature Sensor\)"](#).

Is the inspection result normal?

YES >> GO TO 2.

NO >> Replace engine coolant temperature sensor. Refer to [EM-264, "Exploded View"](#).

### 2. CHECK THERMOSTAT

Remove and Check the thermostat. Refer to [CO-48, "Removal and Installation"](#) and [CO-49, "Inspection"](#).

Is the inspection result normal?

YES >> INSPECTION END

NO >> Replace thermostat. Refer to [CO-48, "Exploded View"](#).

## Component Inspection (Engine Coolant Temperature Sensor)

INFOID:000000007187514

### 1. CHECK ENGINE COOLANT TEMPERATURE (ECT) SENSOR

1. Turn ignition switch OFF.
2. Disconnect ECT sensor harness connector.
3. Remove ECT sensor. Refer to [EM-264, "Exploded View"](#).
4. Check resistance between ECT sensor terminals by heating with hot water as shown in the figure.

| Terminals | Condition             | Resistance (kΩ) |               |
|-----------|-----------------------|-----------------|---------------|
| 1 and 2   | Temperature [°C (°F)] | 20 (68)         | 2.1 - 2.9     |
|           |                       | 50 (122)        | 0.68 - 1.00   |
|           |                       | 90 (194)        | 0.236 - 0.260 |

Is the inspection result normal?

YES >> INSPECTION END

NO >> Replace ECT sensor. Refer to [EM-264, "Exploded View"](#).

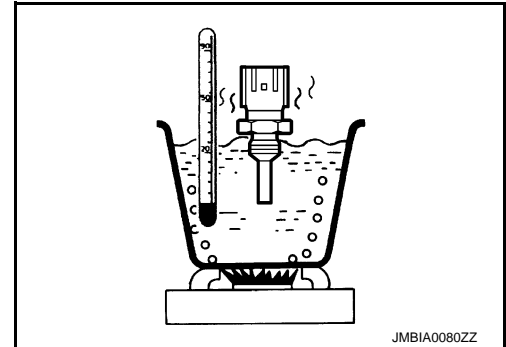

# P0130, P0150 A/F SENSOR 1

< DTC/CIRCUIT DIAGNOSIS >

[VK56VD FOR USA AND CANADA]

## P0130, P0150 A/F SENSOR 1

### DTC Logic

INFOID:000000007187515

#### DTC DETECTION LOGIC

To judge malfunctions, the diagnosis checks that the A/F signal computed by ECM from the A/F sensor 1 signal fluctuates according to fuel feedback control.

| DTC No. | Trouble diagnosis name<br>(Trouble diagnosis content)                   | DTC detecting condition |  | Possible Cause  |
|---------|---|-------------------------|--|---|
| P0130   | A/F SENSOR1 (B1)<br>[Air fuel ratio (A/F) sensor 1<br>(bank 1) circuit] | A)                      | The A/F signal computed by ECM from the A/F sensor 1 signal is constantly in a range other than approx. 1.5 V. | • Harness or connectors<br>(The A/F sensor 1 circuit is open or shorted.)<br>• A/F sensor 1 |
|         |   | B)                      | The A/F signal computed by ECM from the A/F sensor 1 signal is constantly approx. 1.5 V.                       |   |
| P0150   | A/F SENSOR1 (B2)<br>[Air fuel ratio (A/F) sensor 1<br>(bank 2) circuit] | A)                      | The A/F signal computed by ECM from the A/F sensor 1 signal is constantly in a range other than approx. 1.5 V. |   |
|         |   | B)                      | The A/F signal computed by ECM from the A/F sensor 1 signal is constantly approx. 1.5 V.                       |   |

#### DTC CONFIRMATION PROCEDURE

##### 1. PRECONDITIONING

1. Turn ignition switch OFF and wait at least 10 seconds.
2. Turn ignition switch ON.
3. Turn ignition switch OFF and wait at least 10 seconds.

##### TESTING CONDITION:

Before performing the following procedure, confirm that battery voltage is 11 V or more at idle.

>> GO TO 2.

##### 2. PERFORM DTC CONFIRMATION PROCEDURE FOR MALFUNCTION A

1. Start engine and warm it up to normal operating temperature.
2. Let engine idle for 2 minutes.
3. Check 1st trip DTC.

##### Is 1st trip DTC detected?

- YES >> Proceed to [EC-1231. "Diagnosis Procedure"](#).  
NO-1 >> With CONSULT: GO TO 3.  
NO-2 >> With GST: GO TO 7.

##### 3. CHECK AIR FUEL RATIO (A/F) SENSOR 1 FUNCTION

###### Ⓜ WITH CONSULT

1. Start engine and warm it up to normal operating temperature.
2. Select "A/F SEN1 (B1)" or "A/F SEN1 (B2)" in "DATA MONITOR" mode with CONSULT.
3. Check "A/F SEN1 (B1)" or "A/F SEN1 (B2)" indication.

##### Does the indication fluctuate around 1.5 V?

- YES >> GO TO 4.  
NO >> Proceed to [EC-1231. "Diagnosis Procedure"](#).

##### 4. PERFORM DTC CONFIRMATION PROCEDURE FOR MALFUNCTION B-I

1. Select "A/F SEN1 (B1) P1276" (for DTC P0130) or "A/F SEN1 (B2) P1286" (for DTC P0150) of "A/F SEN1" in "DTC WORK SUPPORT" mode with CONSULT.
2. Touch "START".
3. When the following conditions are met, "TESTING" will be displayed on the CONSULT screen.

# P0130, P0150 A/F SENSOR 1

< DTC/CIRCUIT DIAGNOSIS >

[VK56VD FOR USA AND CANADA]

|                |                            |
|----------------|----------------------------|
| ENG SPEED      | 1,000 - 3,200 rpm          |
| VHCL SPEED SE  | More than 64 km/h (40 mph) |
| B/FUEL SCHDL   | 1.0 - 8.0 msec             |
| Selector lever | D position                 |

If "TESTING" is not displayed after 20 seconds, retry from step 2.

**CAUTION:**

**Always drive vehicle at a safe speed.**

Is "TESTING" displayed on CONSULT screen?

YES >> GO TO 5.

NO >> Check A/F sensor 1 function again. GO TO 3.

## 5. PERFORM DTC CONFIRMATION PROCEDURE FOR MALFUNCTION B-II

Release accelerator pedal fully.

**NOTE:**

Never apply brake when releasing the accelerator pedal.

Which does "TESTING" change to?

COMPLETED>>GO TO 6.

OUT OF CONDITION>>Retry DTC CONFIRMATION PROCEDURE. GO TO 4.

## 6. PERFORM DTC CONFIRMATION PROCEDURE FOR MALFUNCTION B-III

Touch "SELF-DIAG RESULT".

Which is displayed on CONSULT screen?

YES >> INSPECTION END

NO >> Proceed to [EC-1231, "Diagnosis Procedure"](#).

## 7. PERFORM COMPONENT FUNCTION CHECK FOR MALFUNCTION B

 With GST

Perform component function check. Refer to [EC-1230, "Component Function Check"](#).

**NOTE:**

Use component function check to check the overall function of the A/F sensor 1 circuit. During this check, a 1st trip DTC might not be confirmed.

Is the inspection result normal?

YES >> INSPECTION END

NO >> Proceed to [EC-1231, "Diagnosis Procedure"](#).

## Component Function Check

INFOID:000000007187516

### 1. PERFORM COMPONENT FUNCTION CHECK

 With GST

1. Start engine and warm it up to normal operating temperature.
2. Drive the vehicle at a speed of 80 km/h (50 MPH) for a few minutes in the suitable gear position.
3. Shift the selector lever position to D, then release the accelerator pedal fully until the vehicle speed decreases to 50 km/h (31 MPH).

**CAUTION:**

**Always drive vehicle at a safe speed.**

**NOTE:**

Never apply brake when releasing the accelerator pedal.

4. Repeat steps 2 and 3 for 5 times.
5. Stop the vehicle and turn ignition switch OFF.
6. Wait at least 10 seconds and turn ignition switch ON.
7. Turn ignition switch OFF and wait at least 10 seconds.
8. Restart engine.
9. Repeat steps 2 and 3 for 5 times.
10. Stop the vehicle.
11. Check 1st trip DTC.

# P0130, P0150 A/F SENSOR 1

[VK56VD FOR USA AND CANADA]

< DTC/CIRCUIT DIAGNOSIS >

Is 1st trip DTC detected?

YES >> Proceed to [EC-1231, "Diagnosis Procedure"](#).

NO >> INSPECTION END

## Diagnosis Procedure

INFOID:000000007187517

EC

### 1. CHECK AIR FUEL RATIO SENSOR 1 POWER SUPPLY CIRCUIT

1. Disconnect air fuel ratio (A/F) sensor 1 harness connector.
2. Turn ignition switch ON.
3. Check the voltage between A/F sensor 1 harness connector and ground.

| DTC   | A/F sensor 1 |           |          | Ground | Voltage |
|-------|--------------|-----------|----------|--------|---------|
|       | Bank         | Connector | Terminal |        |         |
| P0130 | 1            | F23       | 4        | Ground | 3.0 V   |
| P0150 | 2            | F24       | 4        |        |         |

Is the inspection result normal?

YES >> GO TO 2.

NO >> Repair open circuit, short to ground or short to power in harness or connectors.

### 2. CHECK A/F SENSOR 1 INPUT SIGNAL CIRCUIT FOR OPEN AND SHORT

1. Turn ignition switch OFF.
2. Disconnect ECM harness connector.
3. Check the continuity between A/F sensor 1 harness connector and ECM harness connector.

| DTC   | A/F sensor 1 |           |          | ECM       |          | Continuity |
|-------|--------------|-----------|----------|-----------|----------|------------|
|       | Bank         | Connector | Terminal | Connector | Terminal |            |
| P0130 | 1            | F23       | 3        | F111      | 88       | Existed    |
| P0150 | 2            | F24       | 3        |           | 78       |            |

4. Check the continuity between A/F sensor 1 harness connector and ground, or ECM harness connector and ground.

| DTC   | A/F sensor 1 |           |          | ECM       |          | Ground | Continuity  |
|-------|--------------|-----------|----------|-----------|----------|--------|-------------|
|       | Bank         | Connector | Terminal | Connector | Terminal |        |             |
| P0130 | 1            | F23       | 3        | F111      | 88       | Ground | Not existed |
| P0150 | 2            | F24       | 3        |           | 78       |        |             |

5. Also check harness for short to power.

Is the inspection result normal?

YES >> GO TO 3.

NO >> Repair open circuit, short to ground or short to power in harness or connectors.

### 3. CHECK A/F SENSOR 1 GROUND CIRCUIT FOR OPEN AND SHORT

1. Turn ignition switch OFF.
2. Disconnect ECM harness connector.
3. Check the continuity between A/F sensor 1 harness connector and ECM harness connector.

| DTC   | A/F sensor 1 |           |          | ECM       |          | Continuity |
|-------|--------------|-----------|----------|-----------|----------|------------|
|       | Bank         | Connector | Terminal | Connector | Terminal |            |
| P0130 | 1            | F23       | 6        | F111      | 94       | Existed    |
| P0150 | 2            | F24       | 6        |           | 74       |            |

4. Also check harness for short to power.

Is the inspection result normal?

## P0130, P0150 A/F SENSOR 1

[VK56VD FOR USA AND CANADA]

< DTC/CIRCUIT DIAGNOSIS >

---

YES >> GO TO 4.

NO >> Repair open circuit, short to ground or short to power in harness or connectors.

### 4.CHECK INTERMITTENT INCIDENT

---

Refer to [GI-44. "Intermittent Incident"](#).

Is the inspection result normal?

YES >> GO TO 5.

NO >> Repair or replace malfunctioning part.

### 5.REPLACE A/F SENSOR 1

---

Replace malfunctioning A/F sensor 1. Refer to [EM-223. "Exploded View"](#).

#### **CAUTION:**

- Discard any A/F sensor which has been dropped from a height of more than 0.5 m (19.7 in) onto a hard surface such as a concrete floor; use a new one.
- Before installing new A/F sensor, clean exhaust system threads using Oxygen Sensor Thread Cleaner [commercial service tool (J-43897-18 or J-43897-12)] and approved anti-seize lubricant (commercial service tool).

>> INSPECTION END



# P0131, P0151 A/F SENSOR 1

< DTC/CIRCUIT DIAGNOSIS >

[VK56VD FOR USA AND CANADA]

## P0131, P0151 A/F SENSOR 1

### DTC Logic

INFOID:000000007187518

#### DTC DETECTION LOGIC

To judge the malfunction, the diagnosis checks that the A/F signal computed by ECM from the A/F sensor 1 signal is not inordinately low.

| DTC No. | Trouble diagnosis name<br>(Trouble diagnosis content)                               | DTC detecting condition  | Possible Cause  |
|---------|---|--|---|
| P0131   | A/F SENSOR1 (B1)<br>[Air fuel ratio (A/F) sensor 1<br>(bank 1) circuit low voltage] | • The A/F signal computed by ECM from the A/F sensor 1 signal is constantly approx. 0 V. | • Harness or connectors<br>(The A/F sensor 1 circuit is open or shorted.)<br>• A/F sensor 1 |
| P0151   | A/F SENSOR1 (B2)<br>[Air fuel ratio (A/F) sensor 1<br>(bank 2) circuit low voltage] |  |   |

#### DTC CONFIRMATION PROCEDURE

##### 1. PRECONDITIONING

1. Turn ignition switch OFF and wait at least 10 seconds.
2. Turn ignition switch ON.
3. Turn ignition switch OFF and wait at least 10 seconds.

##### TESTING CONDITION:

Before performing the following procedure, confirm that battery voltage is 10.5 V or more at idle.

>> GO TO 2.

##### 2. CHECK A/F SENSOR FUNCTION

###### Ⓜ WITH CONSULT

1. Start engine and warm it up to normal operating temperature.
2. Select "A/F SEN1 (B1)" or "A/F SEN1 (B2)" in "DATA MONITOR" mode with CONSULT.
3. Check "A/F SEN1 (B1)" or "A/F SEN1 (B2)" indication.

###### Ⓜ WITH GST

Follow the procedure "With CONSULT" above.

Is the indication constantly approx. 0 V?

- YES >> Proceed to [EC-1234, "Diagnosis Procedure"](#).  
NO >> GO TO 3.

##### 3. PERFORM DTC CONFIRMATION PROCEDURE

###### Ⓜ WITH CONSULT

1. Turn ignition switch OFF and wait at least 10 seconds.
2. Turn ignition switch ON.
3. Turn ignition switch OFF and wait at least 10 seconds.
4. Restart engine.
5. Drive and accelerate vehicle to more than 40 km/h (25 MPH) within 20 seconds after restarting engine.

##### CAUTION:

**Always drive vehicle at a safe speed.**

6. Maintain the following conditions for approximately 20 consecutive seconds.

|                |                            |
|----------------|----------------------------|
| ENG SPEED      | 1,000 - 3,200 rpm          |
| VHCL SPEED SE  | More than 40 km/h (25 mph) |
| B/FUEL SCHDL   | 1.5 - 9.0 msec             |
| Selector lever | Suitable position          |

##### NOTE:

- Keep the accelerator pedal as steady as possible during cruising.

# P0131, P0151 A/F SENSOR 1

[VK56VD FOR USA AND CANADA]

## < DTC/CIRCUIT DIAGNOSIS >

- If this procedure is not completed within 1 minute after restarting engine at step 1, return to step 1.

7. Check 1st trip DTC.

 WITH GST

Follow the procedure "With CONSULT" above.

Is 1st trip DTC detected?

- YES >> Proceed to [EC-1234, "Diagnosis Procedure"](#).  
NO >> INSPECTION END

## Diagnosis Procedure

INFOID:000000007187519

### 1. CHECK AIR FUEL RATIO SENSOR 1 POWER SUPPLY CIRCUIT

1. Disconnect air fuel ratio (A/F) sensor 1 harness connector.
2. Turn ignition switch ON.
3. Check the voltage between A/F sensor 1 harness connector and ground.

| DTC   | A/F sensor 1 |           |          | Ground | Voltage |
|-------|--------------|-----------|----------|--------|---------|
|       | Bank         | Connector | Terminal |        |         |
| P0131 | 1            | F23       | 4        | Ground | 3.0 V   |
| P0151 | 2            | F24       | 4        |        |         |

Is the inspection result normal?

- YES >> GO TO 2.  
NO >> Repair open circuit, short to ground or short to power in harness or connectors.

### 2. CHECK A/F SENSOR 1 INPUT SIGNAL CIRCUIT FOR OPEN AND SHORT

1. Turn ignition switch OFF.
2. Disconnect ECM harness connector.
3. Check the continuity between A/F sensor 1 harness connector and ECM harness connector.

| DTC   | A/F sensor 1 |           |          | ECM       |          | Continuity |
|-------|--------------|-----------|----------|-----------|----------|------------|
|       | Bank         | Connector | Terminal | Connector | Terminal |            |
| P0131 | 1            | F23       | 3        | F111      | 88       | Existed    |
| P0151 | 2            | F24       | 3        |           | 78       |            |

4. Check the continuity between A/F sensor 1 harness connector and ground, or ECM harness connector and ground.

| DTC   | A/F sensor 1 |           |          | ECM       |          | Ground | Continuity  |
|-------|--------------|-----------|----------|-----------|----------|--------|-------------|
|       | Bank         | Connector | Terminal | Connector | Terminal |        |             |
| P0131 | 1            | F23       | 3        | F111      | 88       | Ground | Not existed |
| P0151 | 2            | F24       | 3        |           | 78       |        |             |

5. Also check harness for short to power.

Is the inspection result normal?

- YES >> GO TO 3.  
NO >> Repair open circuit, short to ground or short to power in harness or connectors.

### 3. CHECK A/F SENSOR 1 GROUND CIRCUIT FOR OPEN AND SHORT

1. Turn ignition switch OFF.
2. Disconnect ECM harness connector.
3. Check the continuity between A/F sensor 1 harness connector and ECM harness connector.

# P0131, P0151 A/F SENSOR 1

< DTC/CIRCUIT DIAGNOSIS >

[VK56VD FOR USA AND CANADA]

| DTC   | A/F sensor 1 |           |          | ECM       |          | Continuity |
|-------|--------------|-----------|----------|-----------|----------|------------|
|       | Bank         | Connector | Terminal | Connector | Terminal |            |
| P0131 | 1            | F23       | 6        | F111      | 94       | Existed    |
| P0151 | 2            | F24       | 6        |           | 74       |            |

4. Also check harness for short to power.

Is the inspection result normal?

YES >> GO TO 4.

NO >> Repair open circuit, short to ground or short to power in harness or connectors.

## 4.CHECK INTERMITTENT INCIDENT

Refer to [GI-44, "Intermittent Incident"](#).

Is the inspection result normal?

YES >> GO TO 5.

NO >> Repair or replace malfunctioning part.

## 5.REPLACE A/F SENSOR 1

Replace malfunctioning A/F sensor 1. Refer to [EM-223, "Exploded View"](#).

### **CAUTION:**

- Discard any A/F sensor which has been dropped from a height of more than 0.5 m (19.7 in) onto a hard surface such as a concrete floor; use a new one.
- Before installing new A/F sensor, clean exhaust system threads using Oxygen Sensor Thread Cleaner [commercial service tool (J-43897-18 or J-43897-12)] and approved anti-seize lubricant (commercial service tool).

>> INSPECTION END

A

EC

C

D

E

F

G

H

I

J

K

L

M

N

O

P

# P0132, P0152 A/F SENSOR 1

< DTC/CIRCUIT DIAGNOSIS >

[VK56VD FOR USA AND CANADA]

## P0132, P0152 A/F SENSOR 1

### DTC Logic

INFOID:000000007187520

#### DTC DETECTION LOGIC

To judge the malfunction, the diagnosis checks that the A/F signal computed by ECM from the A/F sensor 1 signal is not inordinately high.

| DTC No. | Trouble diagnosis name<br>(Trouble diagnosis content)                                | DTC detecting condition   | Possible Cause   |
|---------|--|---|--|
| P0132   | A/F SENSOR1 (B1)<br>[Air fuel ratio (A/F) sensor 1<br>(bank 1) circuit high voltage] | • The A/F signal computed by ECM from the<br>A/F sensor 1 signal is constantly approx. 5 V. | • Harness or connectors<br>(The A/F sensor 1 circuit is open or<br>shorted.)<br>• A/F sensor 1 |
| P0152   | A/F SENSOR1 (B2)<br>[Air fuel ratio (A/F) sensor 1<br>(bank 2) circuit high voltage] |   |  |

#### DTC CONFIRMATION PROCEDURE

##### 1. PRECONDITIONING

1. Turn ignition switch OFF and wait at least 10 seconds.
2. Turn ignition switch ON.
3. Turn ignition switch OFF and wait at least 10 seconds.

##### TESTING CONDITION:

**Before performing the following procedure, confirm that battery voltage is 10.5 V or more at idle.**

>> GO TO 2.

##### 2. CHECK A/F SENSOR FUNCTION

###### Ⓜ WITH CONSULT

1. Start engine and warm it up to normal operating temperature.
2. Select "A/F SEN1 (B1)" or "A/F SEN1 (B2)" in "DATA MONITOR" mode with CONSULT.
3. Check "A/F SEN1 (B1)" or "A/F SEN1 (B2)" indication.

###### Ⓜ WITH GST

Follow the procedure "With CONSULT" above.

Is the indication constantly approx. 5 V?

- YES >> Proceed to [EC-1237. "Diagnosis Procedure"](#).  
NO >> GO TO 3.

##### 3. PERFORM DTC CONFIRMATION PROCEDURE

###### Ⓜ WITH CONSULT

1. Turn ignition switch OFF and wait at least 10 seconds.
2. Turn ignition switch ON.
3. Turn ignition switch OFF and wait at least 10 seconds.
4. Restart engine.
5. Drive and accelerate vehicle to more than 40 km/h (25 MPH) within 20 seconds after restarting engine.

##### CAUTION:

**Always drive vehicle at a safe speed.**

6. Maintain the following conditions for approximately 20 consecutive seconds.

|                |                            |
|----------------|----------------------------|
| ENG SPEED      | 1,000 - 3,200 rpm          |
| VHCL SPEED SE  | More than 40 km/h (25 mph) |
| B/FUEL SCHDL   | 1.5 - 9.0 msec             |
| Selector lever | Suitable position          |

##### NOTE:

- Keep the accelerator pedal as steady as possible during cruising.

# P0132, P0152 A/F SENSOR 1

[VK56VD FOR USA AND CANADA]

< DTC/CIRCUIT DIAGNOSIS >

- If this procedure is not completed within 1 minute after restarting engine at step 1, return to step 1.

7. Check 1st trip DTC.

 WITH GST

Follow the procedure "With CONSULT" above.

Is 1st trip DTC detected?

- YES >> Proceed to [EC-1237, "Diagnosis Procedure"](#).  
NO >> INSPECTION END

## Diagnosis Procedure

INFOID:000000007187521

### 1. CHECK AIR FUEL RATIO SENSOR 1 POWER SUPPLY CIRCUIT

1. Disconnect air fuel ratio (A/F) sensor 1 harness connector.
2. Turn ignition switch ON.
3. Check the voltage between A/F sensor 1 harness connector and ground.

| DTC   | A/F sensor 1 |           |          | Ground | Voltage |
|-------|--------------|-----------|----------|--------|---------|
|       | Bank         | Connector | Terminal |        |         |
| P0132 | 1            | F23       | 4        | Ground | 3.0 V   |
| P0152 | 2            | F24       | 4        |        |         |

Is the inspection result normal?

- YES >> GO TO 2.  
NO >> Repair open circuit, short to ground or short to power in harness or connectors.

### 2. CHECK A/F SENSOR 1 INPUT SIGNAL CIRCUIT FOR OPEN AND SHORT

1. Turn ignition switch OFF.
2. Disconnect ECM harness connector.
3. Check the continuity between A/F sensor 1 harness connector and ECM harness connector.

| DTC   | A/F sensor 1 |           |          | ECM       |          | Continuity |
|-------|--------------|-----------|----------|-----------|----------|------------|
|       | Bank         | Connector | Terminal | Connector | Terminal |            |
| P0132 | 1            | F23       | 3        | F111      | 88       | Existed    |
| P0152 | 2            | F24       | 3        |           | 78       |            |

4. Check the continuity between A/F sensor 1 harness connector and ground, or ECM harness connector and ground.

| DTC   | A/F sensor 1 |           |          | ECM       |          | Ground | Continuity  |
|-------|--------------|-----------|----------|-----------|----------|--------|-------------|
|       | Bank         | Connector | Terminal | Connector | Terminal |        |             |
| P0132 | 1            | F23       | 3        | F111      | 88       | Ground | Not existed |
| P0152 | 2            | F24       | 3        |           | 78       |        |             |

5. Also check harness for short to power.

Is the inspection result normal?

- YES >> GO TO 3.  
NO >> Repair open circuit, short to ground or short to power in harness or connectors.

### 3. CHECK A/F SENSOR 1 GROUND CIRCUIT FOR OPEN AND SHORT

1. Turn ignition switch OFF.
2. Disconnect ECM harness connector.
3. Check the continuity between A/F sensor 1 harness connector and ECM harness connector.

# P0132, P0152 A/F SENSOR 1

< DTC/CIRCUIT DIAGNOSIS >

[VK56VD FOR USA AND CANADA]

| DTC   | A/F sensor 1 |           |          | ECM       |          | Continuity |
|-------|--------------|-----------|----------|-----------|----------|------------|
|       | Bank         | Connector | Terminal | Connector | Terminal |            |
| P0132 | 1            | F23       | 6        | F111      | 94       | Existed    |
| P0152 | 2            | F24       | 6        |           | 74       |            |

4. Also check harness for short to power.

Is the inspection result normal?

YES >> GO TO 4.

NO >> Repair open circuit, short to ground or short to power in harness or connectors.

## 4.CHECK INTERMITTENT INCIDENT

Refer to [GI-44. "Intermittent Incident"](#).

Is the inspection result normal?

YES >> GO TO 5.

NO >> Repair or replace malfunctioning part.

## 5.REPLACE A/F SENSOR 1

Replace malfunctioning A/F sensor 1. Refer to [EM-223. "Exploded View"](#).

### CAUTION:

- Discard any A/F sensor which has been dropped from a height of more than 0.5 m (19.7 in) onto a hard surface such as a concrete floor; use a new one.
- Before installing new A/F sensor, clean exhaust system threads using Oxygen Sensor Thread Cleaner [commercial service tool (J-43897-18 or J-43897-12)] and approved anti-seize lubricant (commercial service tool).

>> INSPECTION END

# P0133, P0153 A/F SENSOR 1

< DTC/CIRCUIT DIAGNOSIS >

[VK56VD FOR USA AND CANADA]

## P0133, P0153 A/F SENSOR 1

### DTC Logic

INFOID:000000007187522

#### DTC DETECTION LOGIC

To judge the malfunction of A/F sensor 1, this diagnosis measures response time of the A/F signal computed by ECM from the A/F sensor 1 signal. The time is compensated by engine operating (speed and load), fuel feedback control constant, and the A/F sensor 1 temperature index. Judgment is based on whether the compensated time (the A/F signal cycling time index) is inordinately long or not.

| DTC No. | Trouble diagnosis name<br>(Trouble diagnosis content)                                 | DTC detecting condition   | Possible Cause   |
|---------|---|---|--|
| P0133   | A/F SENSOR1 (B1)<br>[Air fuel ratio (A/F) sensor 1<br>(bank 1) circuit slow response] | • The response of the A/F signal computed by ECM from A/F sensor 1 signal takes more than the specified time. | • Harness or connectors<br>(The A/F sensor 1 circuit is open or shorted.)<br>• A/F sensor 1<br>• A/F sensor 1 heater<br>• Fuel pressure<br>• Fuel injector<br>• Intake air leaks<br>• Exhaust gas leaks<br>• PCV<br>• Mass air flow sensor |
| P0153   | A/F SENSOR1 (B2)<br>[Air fuel ratio (A/F) sensor 1<br>(bank 2) circuit slow response] |   |  |

#### DTC CONFIRMATION PROCEDURE

##### 1. PRECONDITIONING

1. Turn ignition switch OFF and wait at least 10 seconds.
2. Turn ignition switch ON.
3. Turn ignition switch OFF and wait at least 10 seconds.

##### TESTING CONDITION:

Before performing the following procedure, confirm that battery voltage is 11 V or more at idle.

Will CONSULT be used?

- YES >> GO TO 2.  
NO >> GO TO 5.

##### 2. PERFORM DTC CONFIRMATION PROCEDURE-I

###### Ⓜ WITH CONSULT

1. Start engine and warm it up to normal operating temperature.
2. Turn ignition switch OFF and wait at least 10 seconds.
3. Turn ignition switch ON.
4. Turn ignition switch OFF and wait at least 10 seconds.
5. Restart engine and keep the engine speed between 3,500 and 4,000 rpm for at least 1 minute under no load.
6. Let engine idle for 1 minute.
7. Select "A/F SEN1(B1) P1278/P1279" (for DTC P0133) or "A/F SEN1(B2) P1288/P1289" (for DTC P0153) of "A/F SEN1" in "DTC WORK SUPPORT" mode with CONSULT.
8. Touch "START".

Is "COMPLETED" displayed on CONSULT screen?

- YES >> GO TO 3  
NO >> GO TO 4.

##### 3. PERFORM DTC CONFIRMATION PROCEDURE-II

Touch "SELF-DIAG RESULT".

Which is displayed on CONSULT screen?

- OK >> INSPECTION END  
NG >> Proceed to [EC-1240. "Diagnosis Procedure"](#).

##### 4. PERFORM DTC CONFIRMATION PROCEDURE-II

# P0133, P0153 A/F SENSOR 1

[VK56VD FOR USA AND CANADA]

## < DTC/CIRCUIT DIAGNOSIS >

1. After perform the following procedure, "TESTING" will be displayed on the CONSULT screen.
  - Increase the engine speed up to between 4,000 and 5,000 rpm and maintain that speed for 10 seconds.
  - Fully release accelerator pedal and then let engine idle for approximately 10 seconds.
2. If "TESTING" is not displayed after 10 seconds, refer to [EC-1142, "Component Function Check"](#).
3. Wait for approximately 20 seconds at idle under the condition that "TESTING" is displayed on the CONSULT screen.
4. Check that "TESTING" changes to "COMPLETED".
  - If "TESTING" changed to "OUT OF CONDITION", refer to [EC-1142, "Component Function Check"](#).
5. Touch "SELF-DIAG RESULT".

Which is displayed on CONSULT screen?

- OK >> INSPECTION END
- NG >> Proceed to [EC-1240, "Diagnosis Procedure"](#).

## 5. CHECK AIR-FUEL RATIO SELF-LEARNING VALUE

 WITH GST

1. Start engine and warm it up to normal operating temperature.
2. Select Service \$01 with GST.
3. Calculate the total value of "Short term fuel trim" and "Long term fuel trim" indications.

Is the total percentage within  $\pm 15\%$ ?

- YES >> GO TO 7.
- NO >> GO TO 6.

## 6. DETECT MALFUNCTIONING PART

Check the following.

- Intake air leaks
- Exhaust gas leaks
- Incorrect fuel pressure
- Lack of fuel
- Fuel injector
- Incorrect PCV hose connection
- PCV valve
- Mass air flow sensor

>> Repair or replace malfunctioning part.

## 7. PERFORM DTC CONFIRMATION PROCEDURE

1. Turn ignition switch OFF and wait at least 10 seconds.
2. Start engine and keep the engine speed between 3,500 and 4,000 rpm for at least 1 minute under no load.
3. Let engine idle for 1 minute.
4. Increase the engine speed up to between 4,000 and 5,000 rpm and maintain that speed for 10 seconds.
5. Fully release accelerator pedal and then let engine idle for approximately 1 minute.
6. Check 1st trip DTC.

Is 1st trip DTC detected?

- YES >> Proceed to [EC-1240, "Diagnosis Procedure"](#).
- NO >> INSPECTION END

## Diagnosis Procedure

INFOID:000000007187523

### 1. RETIGHTEN AIR FUEL RATIO SENSOR 1

Loosen and retighten the air fuel ratio (A/F) sensor 1. Refer to [EM-223, "Exploded View"](#).

>> GO TO 2.

### 2. CHECK EXHAUST GAS LEAKAGE

1. Start engine and run it at idle.



# P0133, P0153 A/F SENSOR 1

[VK56VD FOR USA AND CANADA]

## < DTC/CIRCUIT DIAGNOSIS >

- Listen for an exhaust gas leakage before three way catalyst (manifold).

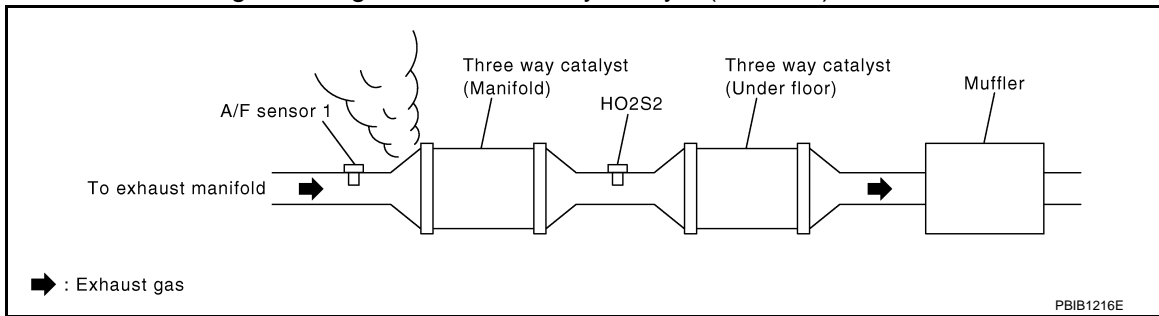

### Is exhaust gas leakage detected?

- YES >> Repair or replace malfunctioning part.  
 NO >> GO TO 3.

## 3.CHECK FOR INTAKE AIR LEAKAGE

Listen for an intake air leakage after the mass air flow sensor.

### Is intake air leakage detected?

- YES >> Repair or replace malfunctioning part.  
 NO >> GO TO 4.

## 4.CLEAR THE MIXTURE RATIO SELF-LEARNING VALUE

- Clear the mixture ratio self-learning value. Refer to [EC-1126, "Work Procedure"](#).
- Run engine for at least 10 minutes at idle speed.

### Is the 1st trip DTC P0171, P172, P0174 or P0175 detected? Is it difficult to start engine?

- YES >> Perform trouble diagnosis for DTC P0171, P0174 or P0172, P0175. Refer to [EC-1264, "DTC Logic"](#) or [EC-1268, "DTC Logic"](#).  
 NO >> GO TO 5.

## 5.CHECK AIR FUEL RATIO SENSOR 1 POWER SUPPLY CIRCUIT

- Disconnect air fuel ratio (A/F) sensor 1 harness connector.
- Turn ignition switch ON.
- Check the voltage between A/F sensor 1 harness connector and ground.

| DTC   | A/F sensor 1 |           |          | Ground | Voltage |
|-------|--------------|-----------|----------|--------|---------|
|       | Bank         | Connector | Terminal |        |         |
| P0133 | 1            | F23       | 4        | Ground | 3.0 V   |
| P0153 | 2            | F24       | 4        |        |         |

### Is the inspection result normal?

- YES >> GO TO 6.  
 NO >> Repair open circuit, short to ground or short to power in harness or connectors.

## 6.CHECK A/F SENSOR 1 INPUT SIGNAL CIRCUIT FOR OPEN AND SHORT

- Turn ignition switch OFF.
- Disconnect ECM harness connector.
- Check the continuity between A/F sensor 1 harness connector and ECM harness connector.

| DTC   | A/F sensor 1 |           |          | ECM       |          | Continuity |
|-------|--------------|-----------|----------|-----------|----------|------------|
|       | Bank         | Connector | Terminal | Connector | Terminal |            |
| P0133 | 1            | F23       | 3        | F111      | 88       | Existed    |
| P0153 | 2            | F24       | 3        |           | 78       |            |

- Check the continuity between A/F sensor 1 harness connector and ground, or ECM harness connector and ground.

# P0133, P0153 A/F SENSOR 1

< DTC/CIRCUIT DIAGNOSIS >

[VK56VD FOR USA AND CANADA]

| DTC   | A/F sensor 1 |           |          | ECM       |          | Ground | Continuity  |
|-------|--------------|-----------|----------|-----------|----------|--------|-------------|
|       | Bank         | Connector | Terminal | Connector | Terminal |        |             |
| P0133 | 1            | F23       | 3        | F111      | 88       | Ground | Not existed |
| P0153 | 2            | F24       | 3        |           | 78       |        |             |

5. Also check harness for short to power.

Is the inspection result normal?

YES >> GO TO 7.

NO >> Repair open circuit, short to ground or short to power in harness or connectors.

## 7.CHECK A/F SENSOR 1 GROUND CIRCUIT FOR OPEN AND SHORT

1. Turn ignition switch OFF.
2. Disconnect ECM harness connector.
3. Check the continuity between A/F sensor 1 harness connector and ECM harness connector.

| DTC   | A/F sensor 1 |           |          | ECM       |          | Continuity |
|-------|--------------|-----------|----------|-----------|----------|------------|
|       | Bank         | Connector | Terminal | Connector | Terminal |            |
| P0133 | 1            | F23       | 6        | F111      | 94       | Existed    |
| P0153 | 2            | F24       | 6        |           | 74       |            |

4. Also check harness for short to power.

Is the inspection result normal?

YES >> GO TO 8.

NO >> Repair open circuit, short to ground or short to power in harness or connectors.

## 8.CHECK A/F SENSOR 1 HEATER

Refer to [EC-1174, "Component Inspection \(A/F Sensor 1 Heater\)"](#).

Is the inspection result normal?

YES >> GO TO 9.

NO >> GO TO 12.

## 9.CHECK MASS AIR FLOW SENSOR

Check both mass air flow sensor (bank 1) and mass air flow sensor (bank 2).

Refer to [EC-1162, "Component Inspection \(MAF Sensor\)"](#).

Is the inspection result normal?

YES >> GO TO 10.

NO >> Replace malfunctioning mass air flow sensor. Refer to [EM-184, "Exploded View"](#).

## 10.CHECK PCV VALVE

Refer to [EC-1552, "Inspection"](#).

Is the inspection result normal?

YES >> GO TO 11.

NO >> Repair or replace PCV valve. Refer to [EM-186, "Exploded View"](#).

## 11.CHECK INTERMITTENT INCIDENT

Refer to [GI-44, "Intermittent Incident"](#).

Is the inspection result normal?

YES >> GO TO 12.

NO >> Repair or replace malfunctioning part.

## 12.REPLACE A/F SENSOR 1

Replace malfunctioning A/F sensor 1. Refer to [EM-223, "Exploded View"](#).

### CAUTION:

- Discard any A/F sensor which has been dropped from a height of more than 0.5 m (19.7 in) onto a hard surface such as a concrete floor; use a new one.

# P0133, P0153 A/F SENSOR 1

< DTC/CIRCUIT DIAGNOSIS >

[VK56VD FOR USA AND CANADA]

- Before installing new A/F sensor, clean exhaust system threads using Oxygen Sensor Thread Cleaner [commercial service tool (J-43897-18 or J-43897-12)] and approved anti-seize lubricant (commercial service tool).

A

>> INSPECTION END

EC

C

D

E

F

G

H

I

J

K

L

M

N

O

P

P0137, P0157 HO2S2

DTC Logic

INFOID:000000007187524

DTC DETECTION LOGIC

The heated oxygen sensor 2 has a much longer switching time between rich and lean than the air fuel ratio (A/F) sensor 1. The oxygen storage capacity of the three way catalyst (manifold) causes the longer switching time. To judge the malfunctions of heated oxygen sensor 2, ECM monitors whether the maximum voltage of the sensor is sufficiently high during various driving conditions such as fuel cut.

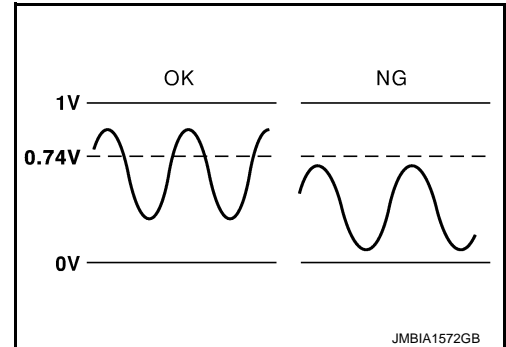

| DTC No. | Trouble diagnosis name<br>(Trouble diagnosis content)                  | DTC detecting condition   | Possible cause  |
|---------|--|---|---|
| P0137   | HO2S2 (B1)<br>[Heated oxygen sensor 2<br>(bank 1) circuit low voltage] | The maximum voltage from the sensor does not reach the specified voltage. | <ul style="list-style-type: none"> <li>• Harness or connectors (The heated oxygen sensor 2 circuit is open or shorted)</li> <li>• Heated oxygen sensor 2</li> <li>• Fuel pressure</li> <li>• Fuel injector</li> <li>• Intake air leaks</li> </ul> |
| P0157   | HO2S2 (B2)<br>[Heated oxygen sensor 2<br>(bank 2) circuit low voltage] |   |   |

DTC CONFIRMATION PROCEDURE

1. PRECONDITIONING

If DTC Confirmation Procedure has been previously conducted, always perform the following procedure before conducting the next test.

1. Turn ignition switch OFF and wait at least 10 seconds.
2. Turn ignition switch ON.
3. Turn ignition switch OFF and wait at least 10 seconds.

Will CONSULT be used?

- YES >> GO TO 2.  
NO >> GO TO 4.

2. PERFORM DTC CONFIRMATION PROCEDURE

Ⓟ WITH CONSULT

TESTING CONDITION:

For better results, perform "DTC WORK SUPPORT" at a temperature of 0 to 30°C (32 to 86°F).

1. Start engine and warm it up to the normal operating temperature.
2. Turn ignition switch OFF and wait at least 10 seconds.
3. Turn ignition switch ON.
4. Turn ignition switch OFF and wait at least 10 seconds.
5. Restart engine and keep the engine speed between 3,500 and 4,000 rpm for at least 1 minute under no load.
6. Let engine idle for 1 minute.
7. Select "DATA MONITOR" mode with CONSULT.
8. Check that "COOLAN TEMP/S" indicates more than 70°C (158°F).  
If not, warm up engine and go to next step when "COOLAN TEMP/S" indication reaches 70°C (158°F).
9. Open engine hood.
10. Select "HO2S2 (B1) P1147" (for DTC P0137) or "HO2S2 (B2) P1167" (for DTC P0157) of "HO2S2" in "DTC WORK SUPPORT" mode with CONSULT.
11. Follow the instruction of CONSULT display.

NOTE:

< DTC/CIRCUIT DIAGNOSIS >

It will take at most 10 minutes until "COMPLETED" is displayed.

12. Touch "SELF-DIAG RESULTS".

Which is displayed on CONSULT screen?

- OK >> INSPECTION END
- NG >> Proceed to [EC-1246, "Diagnosis Procedure"](#).
- CAN NOT BE DIAGNOSED>>GO TO 3.

**3.PERFORM DTC CONFIRMATION PROCEDURE AGAIN**

1. Turn ignition switch OFF and leave the vehicle in a cool place (soak the vehicle).
2. Perform DTC confirmation procedure again.

>> GO TO 2.

**4.PERFORM COMPONENT FUNCTION CHECK**

 WITH GST

Perform component function check. Refer to [EC-1245, "Component Function Check"](#).

**NOTE:**

Use component function check to check the overall function of the heated oxygen sensor 2 circuit. During this check, a 1st trip DTC might not be confirmed.

Is the inspection result normal?

- YES >> INSPECTION END
- NO >> Proceed to [EC-1246, "Diagnosis Procedure"](#).

**Component Function Check**

INFOID:000000007187525

**1.PERFORM COMPONENT FUNCTION CHECK-I**

 With GST

1. Start engine and warm it up to the normal operating temperature.
2. Turn ignition switch OFF and wait at least 10 seconds.
3. Turn ignition switch ON.
4. Turn ignition switch OFF and wait at least 10 seconds.
5. Restart engine and keep the engine speed between 3,500 and 4,000 rpm for at least 1 minute under no load.
6. Let engine idle for 1 minute.
7. Check the voltage between ECM harness connector terminals under the following conditions.

| DTC   | ECM       |          | Condition | Voltage   |   |
|-------|-----------|----------|-----------|---|---|
|       | Connector | +        |           |   | -   |
|       |           | Terminal |           |   | Terminal  |
| P0137 | F111      | 96       | 100       | Revving up to 4,000 rpm under no load at least 10 times | The voltage should be above 0.74 V at least once during this procedure. |
| P0157 |           | 87       |           |   |   |

Is the inspection result normal?

- YES >> INSPECTION END
- NO >> GO TO 2.

**2.PERFORM COMPONENT FUNCTION CHECK-II**

Check the voltage between ECM harness connector terminals under the following conditions.

| DTC   | ECM       |          | Condition | Voltage                               |   |
|-------|-----------|----------|-----------|---------------------------------------|---|
|       | Connector | +        |           |                                       | -   |
|       |           | Terminal |           |                                       | Terminal  |
| P0137 | F111      | 96       | 100       | Keeping engine at idle for 10 minutes | The voltage should be above 0.74 V at least once during this procedure. |
| P0157 |           | 87       |           |                                       |   |

Is the inspection result normal?

# P0137, P0157 HO2S2

[VK56VD FOR USA AND CANADA]

## < DTC/CIRCUIT DIAGNOSIS >

YES >> INSPECTION END  
NO >> GO TO 3.

### 3.PERFORM COMPONENT FUNCTION CHECK-III

Check the voltage between ECM harness connector terminals under the following conditions.

| DTC   | ECM       |          |          | Condition  | Voltage   |
|-------|-----------|----------|----------|--|---|
|       | Connector | +        | -        |  |   |
|       |           | Terminal | Terminal |  |   |
| P0137 | F111      | 96       | 100      | Coasting from 80 km/h (50 MPH) with selector lever in the D position | The voltage should be above 0.74 V at least once during this procedure. |
| P0157 |           | 87       |          |  |   |

Is the inspection result normal?

YES >> INSPECTION END  
NO >> Proceed to [EC-1246, "Diagnosis Procedure"](#).

### Diagnosis Procedure

INFOID:000000007187526

#### 1.CLEAR THE MIXTURE RATIO SELF-LEARNING VALUE

1. Clear the mixture ratio self-learning value. Refer to [EC-1126, "Work Procedure"](#).
2. Run engine for at least 10 minutes at idle speed.

Is the 1st trip DTC P0171 or P0174 detected? Is it difficult to start engine?

YES >> Perform trouble diagnosis for DTC P0171 or P0174. Refer to [EC-1264, "DTC Logic"](#).  
NO >> GO TO 2.

#### 2.CHECK HEATED OXYGEN SENSOR 2 GROUND CIRCUIT FOR OPEN AND SHORT

1. Turn ignition switch OFF.
2. Disconnect heated oxygen sensor 2 (HO2S2) harness connector.
3. Disconnect ECM harness connector.
4. Check the continuity between HO2S2 harness connector and ECM harness connector.

| DTC   | HO2S2 |           |          | ECM       |          | Continuity |
|-------|-------|-----------|----------|-----------|----------|------------|
|       | Bank  | Connector | Terminal | Connector | Terminal |            |
| P0137 | 1     | F87       | 1        | F111      | 100      | Existed    |
| P0157 | 2     | F88       | 1        |           |          |            |

5. Also check harness for short to ground and short to power.

Is the inspection result normal?

YES >> GO TO 3.  
NO >> Repair open circuit, short to ground or short to power in harness or connectors.

#### 3.CHECK HO2S2 INPUT SIGNAL CIRCUIT FOR OPEN AND SHORT

1. Check the continuity between HO2S2 harness connector and ECM harness connector.

| DTC   | HO2S2 |           |          | ECM       |          | Continuity |
|-------|-------|-----------|----------|-----------|----------|------------|
|       | Bank  | Connector | Terminal | Connector | Terminal |            |
| P0137 | 1     | F87       | 4        | F111      | 96       | Existed    |
| P0157 | 2     | F88       | 4        |           | 87       |            |

2. Check the continuity between HO2S2 harness connector and ground, or ECM harness connector and ground.

| DTC   | HO2S2 |           |          | ECM       |          | Ground | Continuity  |
|-------|-------|-----------|----------|-----------|----------|--------|-------------|
|       | Bank  | Connector | Terminal | Connector | Terminal |        |             |
| P0137 | 1     | F87       | 4        | F111      | 96       | Ground | Not existed |
| P0157 | 2     | F88       | 4        |           | 87       |        |             |

3. Also check harness for short to power.

Is the inspection result normal?

YES >> GO TO 4.

NO >> Repair open circuit, short to ground or short to power in harness or connectors.

#### 4.CHECK HEATED OXYGEN SENSOR 2

Refer to [EC-1247, "Component Inspection \(HO2 sensor 2\)"](#).

Is the inspection result normal?

YES >> GO TO 6.

NO >> GO TO 5.

#### 5.REPLACE HEATED OXYGEN SENSOR 2

Replace malfunctioning heated oxygen sensor 2. Refer to [EM-223, "Exploded View"](#).

**CAUTION:**

- Discard any heated oxygen sensor which has been dropped from a height of more than 0.5 m (19.7 in) onto a hard surface such as a concrete floor; use a new one.
- Before installing new oxygen sensor, clean exhaust system threads using Oxygen Sensor Thread Cleaner [commercial service tool (J-43897-18 or J-43897-12)] and approved anti-seize lubricant (commercial service tool).

>> INSPECTION END

#### 6.CHECK INTERMITTENT INCIDENT

Refer to [GI-44, "Intermittent Incident"](#).

>> INSPECTION END

### Component Inspection (HO2 sensor 2)

INFOID:000000007187527

#### 1.INSPECTION START

Will CONSULT be used?

Will CONSULT be used?

YES >> GO TO 2.

NO >> GO TO 3.

#### 2.CHECK HEATED OXYGEN SENSOR 2

 WITH CONSULT

1. Start engine and warm it up to the normal operating temperature.
2. Start engine and keep the engine speed between 3,500 and 4,000 rpm for at least 1 minute under no load.
3. Let engine idle for 1 minute.
4. Select "FUEL INJECTION" in "ACTIVE TEST" mode, and select "HO2S2 (B1)/(B2)" as the monitor item with CONSULT.

# P0137, P0157 HO2S2

< DTC/CIRCUIT DIAGNOSIS >

[VK56VD FOR USA AND CANADA]

5. Check "HO2S2 (B1)/(B2)" at idle speed when adjusting "FUEL INJECTION" to  $\pm 25\%$ .

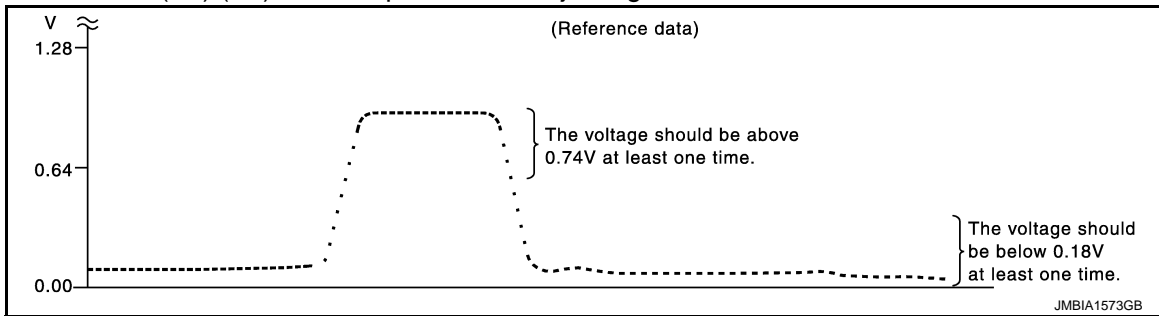

"HO2S2 (B1)/(B2)" should be above 0.74 V at least once when the "FUEL INJECTION" is +25%.

"HO2S2 (B1)/(B2)" should be below 0.18 V at least once when the "FUEL INJECTION" is -25%.

Is the inspection result normal?

YES >> INSPECTION END

NO >> GO TO 6.

## 3. CHECK HEATED OXYGEN SENSOR 2-I

⊗ WITHOUT CONSULT

1. Start engine and warm it up to the normal operating temperature.
2. Turn ignition switch OFF and wait at least 10 seconds.
3. Start engine and keep the engine speed between 3,500 and 4,000 rpm for at least 1 minute under no load.
4. Let engine idle for 1 minute.
5. Check the voltage between ECM harness connector terminals under the following conditions.

| ECM       |                           |          | Condition   | Voltage  |
|-----------|---------------------------|----------|---|--|
| Connector | +                         | -        |   |  |
|           | Terminal                  | Terminal |   |  |
| F111      | 96<br>[HO2S2<br>(bank 1)] | 100      | Revving up to 4,000 rpm under no load at least 10 times | The voltage should be above 0.74 V at least once during this procedure.<br>The voltage should be below 0.18 V at least once during this procedure. |
|           | 87<br>[HO2S2<br>(bank 2)] |          |   |  |

Is the inspection result normal?

YES >> INSPECTION END

NO >> GO TO 4.

## 4. CHECK HEATED OXYGEN SENSOR 2-II

Check the voltage between ECM harness connector terminals under the following conditions.

| ECM       |                           |          | Condition                             | Voltage  |
|-----------|---------------------------|----------|---------------------------------------|--|
| Connector | +                         | -        |                                       |  |
|           | Terminal                  | Terminal |                                       |  |
| F111      | 96<br>[HO2S2<br>(bank 1)] | 100      | Keeping engine at idle for 10 minutes | The voltage should be above 0.74 V at least once during this procedure.<br>The voltage should be below 0.18 V at least once during this procedure. |
|           | 87<br>[HO2S2<br>(bank 2)] |          |                                       |  |

Is the inspection result normal?

YES >> INSPECTION END

NO >> GO TO 5.

## 5. CHECK HEATED OXYGEN SENSOR 2-III

Check the voltage between ECM harness connector terminals under the following conditions.



# P0137, P0157 HO2S2

< DTC/CIRCUIT DIAGNOSIS >

[VK56VD FOR USA AND CANADA]

| ECM       |                           |          | Condition  | Voltage  |
|-----------|---------------------------|----------|--|--|
| Connector | +                         | -        |  |  |
|           | Terminal                  | Terminal |  |  |
| F111      | 96<br>[HO2S2<br>(bank 1)] | 100      | Coasting from 80 km/h (50 MPH) with selector lever in the D position | The voltage should be above 0.74 V at least once during this procedure.<br>The voltage should be below 0.18 V at least once during this procedure. |
|           | 87<br>[HO2S2<br>(bank 2)] |          |  |  |

Is the inspection result normal?

YES >> INSPECTION END

NO >> GO TO 6.

## 6. REPLACE HEATED OXYGEN SENSOR 2

Replace malfunctioning heated oxygen sensor 2. Refer to [EM-223. "Exploded View"](#).

### CAUTION:

- Discard any heated oxygen sensor which has been dropped from a height of more than 0.5 m (19.7 in) onto a hard surface such as a concrete floor; use a new one.
- Before installing new oxygen sensor, clean exhaust system threads using Oxygen Sensor Thread Cleaner [commercial service tool (J-43897-18 or J-43897-12)] and approved anti-seize lubricant (commercial service tool).

>> INSPECTION END

A  
EC  
C  
D  
E  
F  
G  
H  
I  
J  
K  
L  
M  
N  
O  
P

P0138, P0158 HO2S2

DTC Logic

INFOID:000000007187528

DTC DETECTION LOGIC

The heated oxygen sensor 2 has a much longer switching time between rich and lean than the air fuel ratio (A/F) sensor 1. The oxygen storage capacity of the three way catalyst (manifold) causes the longer switching time.

**MALFUNCTION A**

To judge the malfunctions of heated oxygen sensor 2, ECM monitors whether the voltage is unusually high during various driving conditions such as fuel cut.

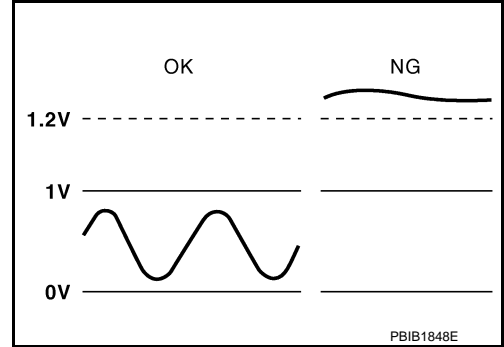

**MALFUNCTION B**

To judge the malfunctions of heated oxygen sensor 2, ECM monitors whether the minimum voltage of sensor is sufficiently low during various driving conditions such as fuel cut.

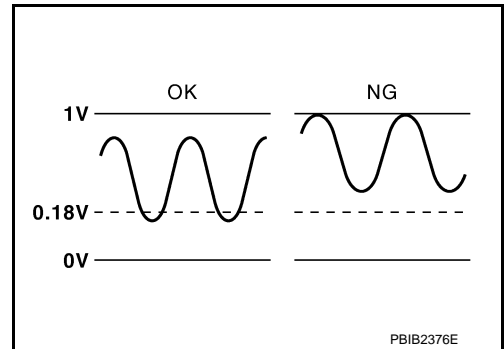

| DTC No. | Trouble diagnosis name<br>(Trouble diagnosis content)                   | DTC detecting condition |  | Possible cause   |
|---------|---|-------------------------|--|--|
| P0138   | HO2S2 (B1)<br>[Heated oxygen sensor 2<br>(bank 1) circuit high voltage] | A)                      | An excessively high voltage from the sensor is sent to ECM.                  | <ul style="list-style-type: none"> <li>• Harness or connectors (The heated oxygen sensor 2 (bank 1) circuit is open or shorted)</li> <li>• Heated oxygen sensor 2</li> </ul>   |
|         |   | B)                      | The minimum voltage from the sensor is not reached to the specified voltage. | <ul style="list-style-type: none"> <li>• Harness or connectors (The heated oxygen sensor 2 (bank 1) circuit is open or shorted)</li> <li>• Heated oxygen sensor 2</li> <li>• Fuel pressure</li> <li>• Fuel injector</li> </ul> |
| P0158   | HO2S2 (B2)<br>[Heated oxygen sensor 2<br>(bank 2) circuit high voltage] | A)                      | An excessively high voltage from the sensor is sent to ECM.                  | <ul style="list-style-type: none"> <li>• Harness or connectors (The heated oxygen sensor 2 (bank 2) circuit is open or shorted)</li> <li>• Heated oxygen sensor 2</li> </ul>   |
|         |   | B)                      | The minimum voltage from the sensor is not reached to the specified voltage. | <ul style="list-style-type: none"> <li>• Harness or connectors (The heated oxygen sensor 2 (bank 2) circuit is open or shorted)</li> <li>• Heated oxygen sensor 2</li> <li>• Fuel pressure</li> <li>• Fuel injector</li> </ul> |

DTC CONFIRMATION PROCEDURE

**1. PRECONDITIONING**

If DTC Confirmation Procedure has been previously conducted, always perform the following procedure before conducting the next test.

1. Turn ignition switch OFF and wait at least 10 seconds.
2. Turn ignition switch ON.
3. Turn ignition switch OFF and wait at least 10 seconds.

>> GO TO 2.

**2. PERFORM DTC CONFIRMATION PROCEDURE FOR MALFUNCTION A**

1. Start engine and warm it up to the normal operating temperature.
2. Turn ignition switch OFF and wait at least 10 seconds.
3. Turn ignition switch ON.
4. Turn ignition switch OFF and wait at least 10 seconds.
5. Start engine and keep the engine speed between 3,500 and 4,000 rpm for at least 1 minute under no load.
6. Let engine idle for 2 minutes.
7. Check 1st trip DTC.

Is 1st trip DTC detected?

YES >> Proceed to [EC-1253. "Diagnosis Procedure"](#).

NO-1 >> With CONSULT: GO TO 3.

NO-2 >> With GST: GO TO 5.

**3. PERFORM DTC CONFIRMATION PROCEDURE FOR MALFUNCTION B**

 WITH CONSULT

**NOTE:**

**For better results, perform "DTC WORK SUPPORT" at a temperature of 0 to 30°C (32 to 86°F).**

1. Start engine and warm it up to the normal operating temperature.
2. Turn ignition switch OFF and wait at least 10 seconds.
3. Turn ignition switch ON.
4. Turn ignition switch OFF and wait at least 10 seconds.
5. Start engine and keep the engine speed between 3,500 and 4,000 rpm for at least 1 minute under no load.
6. Let engine idle for 1 minute.
7. Select "DATA MONITOR" mode with CONSULT.
8. Check that "COOLAN TEMP/S" indicates more than 70°C (158°F).  
If not, warm up engine and go to next step when "COOLAN TEMP/S" indication reaches 70°C (158°F).
9. Open engine hood.
10. Select "HO2S2 (B1) P1146" (for DTC P0138) or "HO2S2 (B2) P1166" (for DTC P0158) of "HO2S2" in "DTC WORK SUPPORT" mode with CONSULT.
11. Follow the instruction of CONSULT display.

**NOTE:**

It will take at most 10 minutes until "COMPLETED" is displayed.

12. Touch "SELF-DIAG RESULTS".

Which is displayed on CONSULT screen?

OK >> INSPECTION END

NG >> Proceed to [EC-1253. "Diagnosis Procedure"](#).

CON NOT BE DIAGNOSED>>GO TO 4.

**4. PERFORM DTC CONFIRMATION PROCEDURE FOR MALFUNCTION B AGAIN**

1. Turn ignition switch OFF and leave the vehicle in a cool place (soak the vehicle).
2. Perform DTC confirmation procedure again.

>> GO TO 3.

**5. PERFORM COMPONENT FUNCTION CHECK FOR MALFUNCTION B**

 WITH GST

Perform component function check. Refer to [EC-1252. "Component Function Check"](#).

**NOTE:**

< DTC/CIRCUIT DIAGNOSIS >

Use component function check to check the overall function of the heated oxygen sensor 2 circuit. During this check, a 1st trip DTC might not be confirmed.

Is the inspection result normal?

- YES >> INSPECTION END
- NO >> Proceed to [EC-1253, "Diagnosis Procedure"](#).

**Component Function Check**

INFOID:000000007187529

**1.PERFORM COMPONENT FUNCTION CHECK-I**

 With GST

1. Start engine and warm it up to the normal operating temperature.
2. Turn ignition switch OFF and wait at least 10 seconds.
3. Turn ignition switch ON.
4. Turn ignition switch OFF and wait at least 10 seconds.
5. Start engine and keep the engine speed between 3,500 and 4,000 rpm for at least 1 minute under no load.
6. Let engine idle for 1 minute.
7. Check the voltage between ECM harness connector terminals under the following conditions.

| DTC   | Connector | ECM      |          | Condition   | Voltage   |
|-------|-----------|----------|----------|---|---|
|       |           | +        | -        |   |   |
|       |           | Terminal | Terminal |   |   |
| P0138 | F111      | 96       | 100      | Revving up to 4,000 rpm under no load at least 10 times | The voltage should be below 0.18 V at least once during this procedure. |
| P0158 |           | 87       |          |   |   |

Is the inspection result normal?

- YES >> INSPECTION END
- NO >> GO TO 2.

**2.PERFORM COMPONENT FUNCTION CHECK-II**

Check the voltage between ECM harness connector terminals under the following conditions.

| DTC   | Connector | ECM      |          | Condition                             | Voltage   |
|-------|-----------|----------|----------|---------------------------------------|---|
|       |           | +        | -        |                                       |   |
|       |           | Terminal | Terminal |                                       |   |
| P0138 | F111      | 96       | 100      | Keeping engine at idle for 10 minutes | The voltage should be below 0.18 V at least once during this procedure. |
| P0158 |           | 87       |          |                                       |   |

Is the inspection result normal?

- YES >> INSPECTION END
- NO >> GO TO 3.

**3.PERFORM COMPONENT FUNCTION CHECK-III**

Check the voltage between ECM harness connector terminals under the following conditions.

| DTC   | Connector | ECM      |          | Condition  | Voltage   |
|-------|-----------|----------|----------|--|---|
|       |           | +        | -        |  |   |
|       |           | Terminal | Terminal |  |   |
| P0138 | F111      | 96       | 100      | Coasting from 80 km/h (50 MPH) with selector lever in the D position | The voltage should be below 0.18 V at least once during this procedure. |
| P0158 |           | 87       |          |  |   |

Is the inspection result normal?

- YES >> INSPECTION END
- NO >> Proceed to [EC-1253, "Diagnosis Procedure"](#).

Diagnosis Procedure

1.INSPECTION START

Confirm the detected malfunction (A or B). Refer to [EC-1250, "DTC Logic"](#).

Which malfunction is detected?

- A >> GO TO 2
- B >> GO TO 8.

2.CHECK HEATED OXYGEN SENSOR 2 CONNECTOR

1. Disconnect heated oxygen sensor 2 (HO2S2) harness connector.
2. Check that water is not inside connectors.

Is the inspection result normal?

- YES >> GO TO 3.
- NO >> Repair or replace harness or connectors.

3.CHECK HO2S2 GROUND CIRCUIT FOR OPEN AND SHORT

1. Disconnect ECM harness connector.
2. Check the continuity between HO2S2 harness connector and ECM harness connector.

| DTC   | HO2S2 |           |          | ECM       |          | Continuity |
|-------|-------|-----------|----------|-----------|----------|------------|
|       | Bank  | Connector | Terminal | Connector | Terminal |            |
| P0138 | 1     | F87       | 1        | F111      | 100      | Existed    |
| P0158 | 2     | F88       | 1        |           |          |            |

3. Also check harness for short to ground and short to power.

Is the inspection result normal?

- YES >> GO TO 4.
- NO >> Repair open circuit, short to ground or short to power in harness or connectors.

4.CHECK HO2S2 INPUT SIGNAL CIRCUIT FOR OPEN AND SHORT

1. Check the continuity between HO2S2 harness connector and ECM harness connector.

| DTC   | HO2S2 |           |          | ECM       |          | Continuity |
|-------|-------|-----------|----------|-----------|----------|------------|
|       | Bank  | Connector | Terminal | Connector | Terminal |            |
| P0138 | 1     | F87       | 4        | F111      | 96       | Existed    |
| P0158 | 2     | F88       | 4        |           | 87       |            |

2. Check the continuity between HO2S2 harness connector and ground, or ECM harness connector and ground.

| DTC   | HO2S2 |           |          | ECM       |          | Ground | Continuity  |
|-------|-------|-----------|----------|-----------|----------|--------|-------------|
|       | Bank  | Connector | Terminal | Connector | Terminal |        |             |
| P0138 | 1     | F87       | 4        | F111      | 96       | Ground | Not existed |
| P0158 | 2     | F88       | 4        |           | 87       |        |             |

3. Also check harness for short to power.

Is the inspection result normal?

- YES >> GO TO 5.
- NO >> Repair open circuit, short to ground or short to power in harness or connectors.

5.CHECK HEATED OXYGEN SENSOR 2

Refer to [EC-1255, "Component Inspection \(HO2 sensor 2\)"](#).

Is the inspection result normal?

- YES >> GO TO 7.
- NO >> GO TO 6.

A  
EC  
C  
D  
E  
F  
G  
H  
I  
J  
K  
L  
M  
N  
O  
P

< DTC/CIRCUIT DIAGNOSIS >

**6. REPLACE HEATED OXYGEN SENSOR 2**

Replace malfunctioning heated oxygen sensor 2. Refer to [EM-223, "Exploded View"](#).

**CAUTION:**

- Discard any heated oxygen sensor which has been dropped from a height of more than 0.5 m (19.7 in) onto a hard surface such as a concrete floor; use a new one.
- Before installing new oxygen sensor, clean exhaust system threads using Oxygen Sensor Thread Cleaner [commercial service tool (J-43897-18 or J-43897-12)] and approved anti-seize lubricant (commercial service tool).

>> INSPECTION END

**7. CHECK INTERMITTENT INCIDENT**

Refer to [GI-44, "Intermittent Incident"](#).

>> INSPECTION END

**8. CLEAR THE MIXTURE RATIO SELF-LEARNING VALUE**

1. Clear the mixture ratio self-learning value. Refer to [EC-1126, "Work Procedure"](#).
2. Run engine for at least 10 minutes at idle speed.

Is the 1st trip DTC P0172 or P0175 detected? Is it difficult to start engine?

- YES >> Perform trouble diagnosis for DTC P0172, P0175. Refer to [EC-1268, "DTC Logic"](#).  
 NO >> GO TO 9.

**9. CHECK HEATED OXYGEN SENSOR 2 GROUND CIRCUIT FOR OPEN AND SHORT**

1. Turn ignition switch OFF.
2. Disconnect heated oxygen sensor 2 (HO2S2) harness connector.
3. Disconnect ECM harness connector.
4. Check the continuity between HO2S2 harness connector and ECM harness connector.

| DTC   | HO2S2 |           |          | ECM       |          | Continuity |
|-------|-------|-----------|----------|-----------|----------|------------|
|       | Bank  | Connector | Terminal | Connector | Terminal |            |
| P0138 | 1     | F87       | 1        | F111      | 100      | Existed    |
| P0158 | 2     | F88       | 1        |           |          |            |

5. Also check harness for short to ground and short to power.

Is the inspection result normal?

- YES >> GO TO 10.  
 NO >> Repair open circuit, short to ground or short to power in harness or connectors.

**10. CHECK HO2S2 INPUT SIGNAL CIRCUIT FOR OPEN AND SHORT**

1. Check the continuity between HO2S2 harness connector and ECM harness connector.

| DTC   | HO2S2 |           |          | ECM       |          | Continuity |
|-------|-------|-----------|----------|-----------|----------|------------|
|       | Bank  | Connector | Terminal | Connector | Terminal |            |
| P0138 | 1     | F87       | 4        | F111      | 96       | Existed    |
| P0158 | 2     | F88       | 4        |           | 87       |            |

2. Check the continuity between HO2S2 harness connector and ground, or ECM harness connector and ground.

| DTC   | HO2S2 |           |          | ECM       |          | Ground | Continuity  |
|-------|-------|-----------|----------|-----------|----------|--------|-------------|
|       | Bank  | Connector | Terminal | Connector | Terminal |        |             |
| P0138 | 1     | F87       | 4        | F111      | 96       | Ground | Not existed |
| P0158 | 2     | F88       | 4        |           | 87       |        |             |

< DTC/CIRCUIT DIAGNOSIS >

3. Also check harness for short to power.

Is the inspection result normal?

YES >> GO TO 11.

NO >> Repair open circuit, short to ground or short to power in harness or connectors.

11. CHECK HEATED OXYGEN SENSOR 2

Refer to [EC-1255, "Component Inspection \(HO2 sensor 2\)"](#).

Is the inspection result normal?

YES >> GO TO 13.

NO >> GO TO 12.

12. REPLACE HEATED OXYGEN SENSOR 2

Replace malfunctioning heated oxygen sensor 2. Refer to [EM-223, "Exploded View"](#).

**CAUTION:**

- Discard any heated oxygen sensor which has been dropped from a height of more than 0.5 m (19.7 in) onto a hard surface such as a concrete floor; use a new one.
- Before installing new oxygen sensor, clean exhaust system threads using Oxygen Sensor Thread Cleaner [commercial service tool (J-43897-18 or J-43897-12)] and approved anti-seize lubricant (commercial service tool).

>> INSPECTION END

13. CHECK INTERMITTENT INCIDENT

Refer to [GI-44, "Intermittent Incident"](#).

>> INSPECTION END

Component Inspection (HO2 sensor 2)

INFOID:000000007187531

1. INSPECTION START

Will CONSULT be used?

Will CONSULT be used?

YES >> GO TO 2.

NO >> GO TO 3.

2. CHECK HEATED OXYGEN SENSOR 2

 WITH CONSULT

1. Start engine and warm it up to the normal operating temperature.
2. Start engine and keep the engine speed between 3,500 and 4,000 rpm for at least 1 minute under no load.
3. Let engine idle for 1 minute.
4. Select "FUEL INJECTION" in "ACTIVE TEST" mode, and select "HO2S2 (B1)/(B2)" as the monitor item with CONSULT.
5. Check "HO2S2 (B1)/(B2)" at idle speed when adjusting "FUEL INJECTION" to  $\pm 25\%$ .

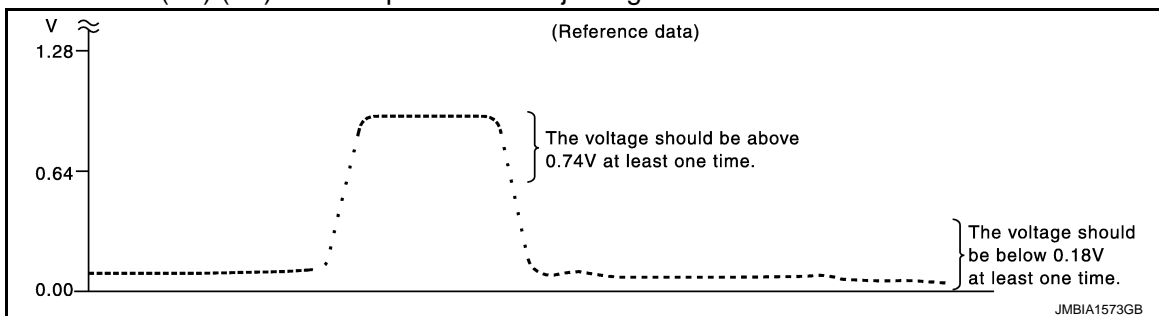

"HO2S2 (B1)/(B2)" should be above 0.74 V at least once when the "FUEL INJECTION" is +25%.  
 "HO2S2 (B1)/(B2)" should be below 0.18 V at least once when the "FUEL INJECTION" is -25%.

Is the inspection result normal?

YES >> INSPECTION END

< DTC/CIRCUIT DIAGNOSIS >

NO >> GO TO 6.

**3.CHECK HEATED OXYGEN SENSOR 2-I**

⊗ WITHOUT CONSULT

1. Start engine and warm it up to the normal operating temperature.
2. Turn ignition switch OFF and wait at least 10 seconds.
3. Start engine and keep the engine speed between 3,500 and 4,000 rpm for at least 1 minute under no load.
4. Let engine idle for 1 minute.
5. Check the voltage between ECM harness connector terminals under the following conditions.

| Connector | ECM                       |          | Condition  | Voltage  |
|-----------|---------------------------|----------|--|--|
|           | +                         | -        |  |  |
|           | Terminal                  | Terminal |  |  |
| F111      | 96<br>[HO2S2<br>(bank 1)] | 100      | Revvng up to 4,000 rpm under no load at least 10 times | The voltage should be above 0.74 V at least once during this procedure.<br>The voltage should be below 0.18 V at least once during this procedure. |
|           | 87<br>[HO2S2<br>(bank 2)] |          |  |  |

Is the inspection result normal?

YES >> INSPECTION END

NO >> GO TO 4.

**4.CHECK HEATED OXYGEN SENSOR 2-II**

Check the voltage between ECM harness connector terminals under the following conditions.

| Connector | ECM                       |          | Condition                             | Voltage  |
|-----------|---------------------------|----------|---------------------------------------|--|
|           | +                         | -        |                                       |  |
|           | Terminal                  | Terminal |                                       |  |
| F111      | 96<br>[HO2S2<br>(bank 1)] | 100      | Keeping engine at idle for 10 minutes | The voltage should be above 0.74 V at least once during this procedure.<br>The voltage should be below 0.18 V at least once during this procedure. |
|           | 87<br>[HO2S2<br>(bank 2)] |          |                                       |  |

Is the inspection result normal?

YES >> INSPECTION END

NO >> GO TO 5.

**5.CHECK HEATED OXYGEN SENSOR 2-III**

Check the voltage between ECM harness connector terminals under the following conditions.

| Connector | ECM                       |          | Condition  | Voltage  |
|-----------|---------------------------|----------|--|--|
|           | +                         | -        |  |  |
|           | Terminal                  | Terminal |  |  |
| F111      | 96<br>[HO2S2<br>(bank 1)] | 100      | Coasting from 80 km/h (50 MPH) with selector lever in the D position | The voltage should be above 0.74 V at least once during this procedure.<br>The voltage should be below 0.18 V at least once during this procedure. |
|           | 87<br>[HO2S2<br>(bank 2)] |          |  |  |

Is the inspection result normal?

YES >> INSPECTION END

NO >> GO TO 6.



# P0138, P0158 HO2S2

< DTC/CIRCUIT DIAGNOSIS >

[VK56VD FOR USA AND CANADA]

## 6. REPLACE HEATED OXYGEN SENSOR 2

Replace malfunctioning heated oxygen sensor 2. Refer to [EM-223. "Exploded View"](#).

**CAUTION:**

- Discard any heated oxygen sensor which has been dropped from a height of more than 0.5 m (19.7 in) onto a hard surface such as a concrete floor; use a new one.
- Before installing new oxygen sensor, clean exhaust system threads using Oxygen Sensor Thread Cleaner [commercial service tool (J-43897-18 or J-43897-12)] and approved anti-seize lubricant (commercial service tool).

>> INSPECTION END

A

EC

C

D

E

F

G

H

I

J

K

L

M

N

O

P

P0139, P0159 HO2S2

DTC Logic

INFOID:000000007187532

DTC DETECTION LOGIC

The heated oxygen sensor 2 has a much longer switching time between rich and lean than the air fuel ratio (A/F) sensor 1. The oxygen storage capacity of the three way catalyst (manifold) causes the longer switching time. To judge the malfunctions of heated oxygen sensor 2, ECM monitors whether the switching response of the sensor's voltage is faster than specified during various driving conditions such as fuel cut.

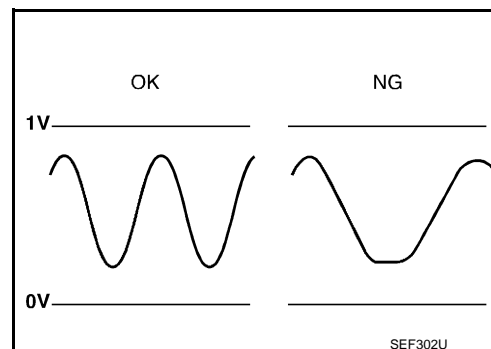

| DTC No. | Trouble diagnosis name<br>(Trouble diagnosis content)                    | DTC detecting condition   | Possible cause  |
|---------|--|---|---|
| P0139   | HO2S2 (B1)<br>[Heated oxygen sensor 2<br>(bank 1) circuit slow response] | It takes more time for the sensor to respond between rich and lean than the specified time. | <ul style="list-style-type: none"> <li>• Harness or connectors (The heated oxygen sensor 2 circuit is open or shorted)</li> <li>• Heated oxygen sensor 2</li> <li>• Fuel pressure</li> <li>• Fuel injector</li> <li>• Intake air leaks</li> </ul> |
| P0159   | HO2S2 (B2)<br>[Heated oxygen sensor 2<br>(bank 2) circuit slow response] |   |   |

DTC CONFIRMATION PROCEDURE

1. PRECONDITIONING

If DTC Confirmation Procedure has been previously conducted, always perform the following procedure before conducting the next test.

1. Turn ignition switch OFF and wait at least 10 seconds.
2. Turn ignition switch ON.
3. Turn ignition switch OFF and wait at least 10 seconds.

Will CONSULT be used?

- YES >> GO TO 2.
- NO >> GO TO 4.

2. PERFORM DTC CONFIRMATION PROCEDURE

Ⓟ WITH CONSULT

TESTING CONDITION:

For better results, perform "DTC WORK SUPPORT" at a temperature of 0 to 30°C (32 to 86°F).

1. Start engine and warm it up to the normal operating temperature.
2. Turn ignition switch OFF and wait at least 10 seconds.
3. Turn ignition switch ON.
4. Turn ignition switch OFF and wait at least 10 seconds.
5. Restart engine and keep the engine speed between 3,500 and 4,000 rpm for at least 1 minute under no load.
6. Let engine idle for 1 minute.
7. Select "DATA MONITOR" mode with CONSULT.
8. Check that "COOLAN TEMP/S" indicates more than 70°C (158°F).  
If not, warm up engine and go to next step when "COOLAN TEMP/S" indication reaches to 70°C (158°F).
9. Open engine hood.
10. Select "HO2S2 (B1) P0139" or "HO2S2 (B2) P0159" of "HO2S2" in "DTC WORK SUPPORT" mode with CONSULT.
11. Start engine and follow the instruction of CONSULT display.

NOTE:

< DTC/CIRCUIT DIAGNOSIS >

It will take at most 10 minutes until "COMPLETED" is displayed.

12. Touch "SELF-DIAG RESULTS".

Which is displayed on CONSULT screen?

- OK >> INSPECTION END
- NG >> Proceed to [EC-1260, "Diagnosis Procedure"](#).
- CAN NOT BE DIAGNOSED>>GO TO 3.

**3.PERFORM DTC CONFIRMATION PROCEDURE AGAIN**

1. Turn ignition switch OFF and leave the vehicle in a cool place (soak the vehicle).
2. Perform DTC confirmation procedure again.

>> GO TO 2.

**4.PERFORM COMPONENT FUNCTION CHECK**

 WITH GST

Perform component function check. Refer to [EC-1259, "Component Function Check"](#).

**NOTE:**

Use component function check to check the overall function of the heated oxygen sensor 2 circuit. During this check, a 1st trip DTC might not be confirmed.

Is the inspection result normal?

- YES >> INSPECTION END
- NO >> Proceed to [EC-1260, "Diagnosis Procedure"](#).

**Component Function Check**

INFOID:000000007187533

**1.PERFORM COMPONENT FUNCTION CHECK-I**

 With GST

1. Start engine and warm it up to the normal operating temperature.
2. Turn ignition switch OFF and wait at least 10 seconds.
3. Turn ignition switch ON.
4. Turn ignition switch OFF and wait at least 10 seconds.
5. Restart engine and keep the engine speed between 3,500 and 4,000 rpm for at least 1 minute under no load.
6. Let engine idle for 1 minute.
7. Check the voltage between ECM harness connector terminals under the following conditions.

| DTC   | ECM       |          | Condition | Voltage   |  |
|-------|-----------|----------|-----------|---|--|
|       | Connector | +        |           |   | -  |
|       |           | Terminal |           |   | Terminal   |
| P0139 | F111      | 96       | 100       | Revving up to 4,000 rpm under no load at least 10 times |  |
| P0159 |           | 87       |           |   | A change of voltage should be more than 0.24 V for 1 second during this procedure. |

Is the inspection result normal?

- YES >> INSPECTION END
- NO >> GO TO 2.

**2.PERFORM COMPONENT FUNCTION CHECK-II**

Check the voltage between ECM harness connector terminals under the following conditions.

| DTC   | ECM       |          | Condition | Voltage                               |  |
|-------|-----------|----------|-----------|---------------------------------------|--|
|       | Connector | +        |           |                                       | -  |
|       |           | Terminal |           |                                       | Terminal   |
| P0139 | F111      | 96       | 100       | Keeping engine at idle for 10 minutes |  |
| P0159 |           | 87       |           |                                       | A change of voltage should be more than 0.24 V for 1 second during this procedure. |

Is the inspection result normal?

# P0139, P0159 HO2S2

[VK56VD FOR USA AND CANADA]

< DTC/CIRCUIT DIAGNOSIS >

YES >> INSPECTION END  
NO >> GO TO 3.

## 3.PERFORM COMPONENT FUNCTION CHECK-III

Check the voltage between ECM harness connector terminals under the following conditions.

| DTC   | ECM       |          |          | Condition  | Voltage  |
|-------|-----------|----------|----------|--|--|
|       | Connector | +        | -        |  |  |
|       |           | Terminal | Terminal |  |  |
| P0139 | F111      | 96       | 100      | Coasting from 80 km/h (50 MPH) with selector lever in the D position | A change of voltage should be more than 0.24 V for 1 second during this procedure. |
| P0159 |           | 87       |          |  |  |

Is the inspection result normal?

YES >> INSPECTION END  
NO >> Proceed to [EC-1260, "Diagnosis Procedure"](#).

## Diagnosis Procedure

INFOID:000000007187534

### 1.CLEAR THE MIXTURE RATIO SELF-LEARNING VALUE

1. Clear the mixture ratio self-learning value. Refer to [EC-1126, "Work Procedure"](#).
2. Run engine for at least 10 minutes at idle speed.

Is the 1st trip DTC P0171, P0172, P0174 or P0175 detected? Is it difficult to start engine?

YES >> Perform trouble diagnosis for DTC P0171, P0174 or P0172, P0175. Refer to [EC-1264, "DTC Logic"](#) or [EC-1268, "DTC Logic"](#).  
NO >> GO TO 2.

### 2.CHECK HEATED OXYGEN SENSOR 2 GROUND CIRCUIT FOR OPEN AND SHORT

1. Turn ignition switch OFF.
2. Disconnect heated oxygen sensor 2 (HO2S2) harness connector.
3. Disconnect ECM harness connector.
4. Check the continuity between HO2S2 harness connector and ECM harness connector.

| DTC   | HO2S2 |           |          | ECM       |          | Continuity |
|-------|-------|-----------|----------|-----------|----------|------------|
|       | Bank  | Connector | Terminal | Connector | Terminal |            |
| P0139 | 1     | F87       | 1        | F111      | 100      | Existed    |
| P0159 | 2     | F88       | 1        |           |          |            |

5. Also check harness for short to ground and short to power.

Is the inspection result normal?

YES >> GO TO 3.  
NO >> Repair open circuit, short to ground or short to power in harness or connectors.

### 3.CHECK HO2S2 INPUT SIGNAL CIRCUIT FOR OPEN AND SHORT

1. Check the continuity between HO2S2 harness connector and ECM harness connector.

| DTC   | HO2S2 |           |          | ECM       |          | Continuity |
|-------|-------|-----------|----------|-----------|----------|------------|
|       | Bank  | Connector | Terminal | Connector | Terminal |            |
| P0139 | 1     | F87       | 4        | F111      | 96       | Existed    |
| P0159 | 2     | F88       | 4        |           | 87       |            |

2. Check the continuity between HO2S2 harness connector and ground, or ECM harness connector and ground.

| DTC   | HO2S2 |           |          | ECM       |          | Ground | Continuity  |
|-------|-------|-----------|----------|-----------|----------|--------|-------------|
|       | Bank  | Connector | Terminal | Connector | Terminal |        |             |
| P0139 | 1     | F87       | 4        | F111      | 96       | Ground | Not existed |
| P0159 | 2     | F88       | 4        |           | 87       |        |             |

A

EC

3. Also check harness for short to power.

Is the inspection result normal?

YES >> GO TO 4.

NO >> Repair open circuit, short to ground or short to power in harness or connectors.

#### 4.CHECK HEATED OXYGEN SENSOR 2

Refer to [EC-1261, "Component Inspection \(HO2 sensor 2\)"](#).

Is the inspection result normal?

YES >> GO TO 6.

NO >> GO TO 5.

#### 5.REPLACE HEATED OXYGEN SENSOR 2

Replace malfunctioning heated oxygen sensor 2. Refer to [EM-223, "Exploded View"](#).

#### CAUTION:

- Discard any heated oxygen sensor which has been dropped from a height of more than 0.5 m (19.7 in) onto a hard surface such as a concrete floor; use a new one.
- Before installing new oxygen sensor, clean exhaust system threads using Oxygen Sensor Thread Cleaner [commercial service tool (J-43897-18 or J-43897-12)] and approved anti-seize lubricant (commercial service tool).

>> INSPECTION END

#### 6.CHECK INTERMITTENT INCIDENT

Refer to [GI-44, "Intermittent Incident"](#).

>> INSPECTION END

### Component Inspection (HO2 sensor 2)

INFOID:000000007187535

#### 1.INSPECTION START

Will CONSULT be used?

Will CONSULT be used?

YES >> GO TO 2.

NO >> GO TO 3.

#### 2.CHECK HEATED OXYGEN SENSOR 2

##### Ⓜ WITH CONSULT

1. Start engine and warm it up to the normal operating temperature.
2. Start engine and keep the engine speed between 3,500 and 4,000 rpm for at least 1 minute under no load.
3. Let engine idle for 1 minute.
4. Select "FUEL INJECTION" in "ACTIVE TEST" mode, and select "HO2S2 (B1)/(B2)" as the monitor item with CONSULT.

# P0139, P0159 HO2S2

< DTC/CIRCUIT DIAGNOSIS >

[VK56VD FOR USA AND CANADA]

5. Check "HO2S2 (B1)/(B2)" at idle speed when adjusting "FUEL INJECTION" to  $\pm 25\%$ .

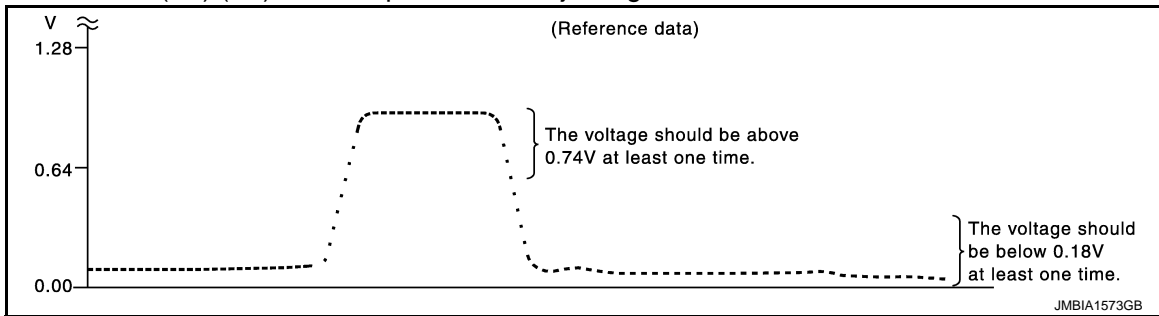

"HO2S2 (B1)/(B2)" should be above 0.74 V at least once when the "FUEL INJECTION" is +25%.

"HO2S2 (B1)/(B2)" should be below 0.18 V at least once when the "FUEL INJECTION" is -25%.

Is the inspection result normal?

YES >> INSPECTION END

NO >> GO TO 6.

## 3. CHECK HEATED OXYGEN SENSOR 2-I

⊗ WITHOUT CONSULT

1. Start engine and warm it up to the normal operating temperature.
2. Turn ignition switch OFF and wait at least 10 seconds.
3. Start engine and keep the engine speed between 3,500 and 4,000 rpm for at least 1 minute under no load.
4. Let engine idle for 1 minute.
5. Check the voltage between ECM harness connector terminals under the following conditions.

| ECM       |                           |          | Condition   | Voltage  |
|-----------|---------------------------|----------|---|--|
| Connector | +                         | -        |   |  |
|           | Terminal                  | Terminal |   |  |
| F111      | 96<br>[HO2S2<br>(bank 1)] | 100      | Revving up to 4,000 rpm under no load at least 10 times | The voltage should be above 0.74 V at least once during this procedure.<br>The voltage should be below 0.18 V at least once during this procedure. |
|           | 87<br>[HO2S2<br>(bank 2)] |          |   |  |

Is the inspection result normal?

YES >> INSPECTION END

NO >> GO TO 4.

## 4. CHECK HEATED OXYGEN SENSOR 2-II

Check the voltage between ECM harness connector terminals under the following conditions.

| ECM       |                           |          | Condition                             | Voltage  |
|-----------|---------------------------|----------|---------------------------------------|--|
| Connector | +                         | -        |                                       |  |
|           | Terminal                  | Terminal |                                       |  |
| F111      | 96<br>[HO2S2<br>(bank 1)] | 100      | Keeping engine at idle for 10 minutes | The voltage should be above 0.74 V at least once during this procedure.<br>The voltage should be below 0.18 V at least once during this procedure. |
|           | 87<br>[HO2S2<br>(bank 2)] |          |                                       |  |

Is the inspection result normal?

YES >> INSPECTION END

NO >> GO TO 5.

## 5. CHECK HEATED OXYGEN SENSOR 2-III

Check the voltage between ECM harness connector terminals under the following conditions.

# P0139, P0159 HO2S2

< DTC/CIRCUIT DIAGNOSIS >

[VK56VD FOR USA AND CANADA]

| ECM       |                           |          | Condition  | Voltage  |
|-----------|---------------------------|----------|--|--|
| Connector | +                         | -        |  |  |
|           | Terminal                  | Terminal |  |  |
| F111      | 96<br>[HO2S2<br>(bank 1)] | 100      | Coasting from 80 km/h (50 MPH) with selector lever in the D position | The voltage should be above 0.74 V at least once during this procedure.<br>The voltage should be below 0.18 V at least once during this procedure. |
|           | 87<br>[HO2S2<br>(bank 2)] |          |  |  |

Is the inspection result normal?

YES >> INSPECTION END

NO >> GO TO 6.

## 6. REPLACE HEATED OXYGEN SENSOR 2

Replace malfunctioning heated oxygen sensor 2. Refer to [EM-223. "Exploded View"](#).

### CAUTION:

- Discard any heated oxygen sensor which has been dropped from a height of more than 0.5 m (19.7 in) onto a hard surface such as a concrete floor; use a new one.
- Before installing new oxygen sensor, clean exhaust system threads using Oxygen Sensor Thread Cleaner [commercial service tool (J-43897-18 or J-43897-12)] and approved anti-seize lubricant (commercial service tool).

>> INSPECTION END

A  
EC  
C  
D  
E  
F  
G  
H  
I  
J  
K  
L  
M  
N  
O  
P

# P0171, P0174 FUEL INJECTION SYSTEM FUNCTION

< DTC/CIRCUIT DIAGNOSIS >

[VK56VD FOR USA AND CANADA]

## P0171, P0174 FUEL INJECTION SYSTEM FUNCTION

### DTC Logic

INFOID:000000007187536

#### DTC DETECTION LOGIC

With the Air/Fuel Mixture Ratio Self-Learning Control, the actual mixture ratio can be brought closely to the theoretical mixture ratio based on the mixture ratio feedback signal from A/F sensor 1. The ECM calculates the necessary compensation to correct the offset between the actual and the theoretical ratios.

In case the amount of the compensation value is extremely large (the actual mixture ratio is too lean), the ECM judges the condition as the fuel injection system malfunction and illuminates the MIL (2 trip detection logic).

| Sensor       | Input signal to ECM  | ECM function           | Actuator      |
|--------------|--|------------------------|---------------|
| A/F sensor 1 | Density of oxygen in exhaust gas (Mixture ratio feedback signal) | Fuel injection control | Fuel injector |

| DTC No. | Trouble diagnosis name (Trouble diagnosis content)         | DTC detecting condition   | Possible cause   |
|---------|--|---|--|
| P0171   | FUEL SYS-LEAN-B1 [Fuel injection system too lean (bank 1)] | • Fuel injection system does not operate properly.<br>• The amount of mixture ratio compensation is too large. (The mixture ratio is too lean.) | • Intake air leakage<br>• A/F sensor 1<br>• Fuel injector<br>• Exhaust gas leakage<br>• Incorrect fuel pressure<br>• Lack of fuel<br>• Mass air flow sensor<br>• Incorrect PCV hose connection |
| P0174   | FUEL SYS-LEAN-B2 [Fuel injection system too lean (bank 2)] |   |  |

#### DTC CONFIRMATION PROCEDURE

##### 1. PRECONDITIONING

If DTC Confirmation Procedure has been previously conducted, always perform the following procedure before conducting the next test.

1. Turn ignition switch OFF and wait at least 10 seconds.
2. Turn ignition switch ON.
3. Turn ignition switch OFF and wait at least 10 seconds.

>> GO TO 2.

##### 2. PERFORM DTC CONFIRMATION PROCEDURE-I

1. Clear the mixture ratio self-learning value. Refer to [EC-1126, "Work Procedure"](#).
2. Start engine.

Is it difficult to start engine?

YES >> GO TO 3.

NO >> GO TO 4.

##### 3. RESTART ENGINE

If it is difficult to start engine, the fuel injection system has a malfunction, too.

Crank engine while depressing accelerator pedal.

#### NOTE:

When depressing accelerator pedal three fourths (3/4) or more, the control system does not start the engine. Do not depress accelerator pedal too much.

Does engine start?

YES >> Proceed to [EC-1265, "Diagnosis Procedure"](#).

NO >> Check exhaust and intake air leakage visually.

##### 4. PERFORM DTC CONFIRMATION PROCEDURE-II

1. Keep engine idle for at least 5 minutes.
2. Check 1st trip DTC.



# P0171, P0174 FUEL INJECTION SYSTEM FUNCTION

[VK56VD FOR USA AND CANADA]

< DTC/CIRCUIT DIAGNOSIS >

Is 1st trip DTC detected?

- YES >> Proceed to [EC-1265, "Diagnosis Procedure"](#).
- NO >> GO TO 5.

## 5.PERFORM DTC CONFIRMATION PROCEDURE-III

1. Turn ignition switch OFF and wait at least 10 seconds.
2. Turn ignition switch ON.
3. Turn ignition switch OFF and wait at least 10 seconds.
4. Start engine.
5. Maintain the following conditions for at least 10 consecutive minutes.  
**Hold the accelerator pedal as steady as possible.**

|               |                             |
|---------------|-----------------------------|
| Vehicle speed | 50 - 120 km/h (31 - 75 MPH) |
|---------------|-----------------------------|

### CAUTION:

**Always drive vehicle at a safe speed.**

6. Check 1st trip DTC.

Is 1st trip DTC detected?

- YES >> Proceed to [EC-1265, "Diagnosis Procedure"](#).
- NO >> INSPECTION END

## Diagnosis Procedure

INFOID:000000007187537

### 1.CHECK EXHAUST GAS LEAKAGE

1. Start engine and run it at idle.
2. Listen for an exhaust gas leakage before three way catalyst (manifold).

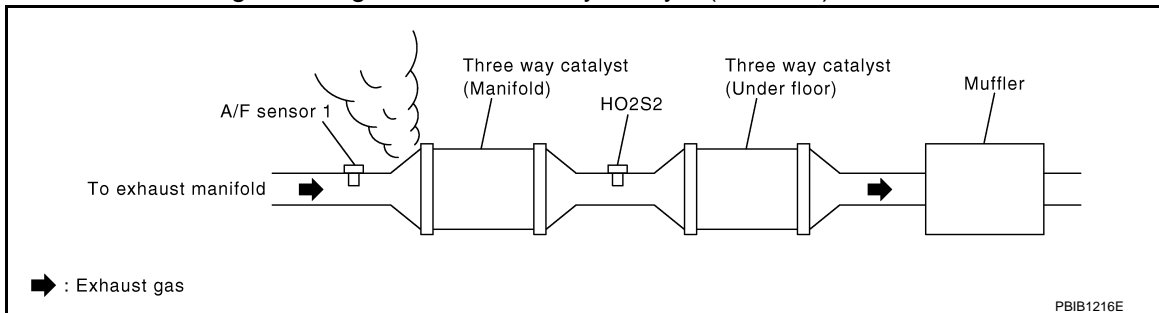

Is exhaust gas leakage detected?

- YES >> Repair or replace malfunctioning part.
- NO >> GO TO 2.

### 2.CHECK FOR INTAKE AIR LEAKAGE

1. Listen for an intake air leakage after the mass air flow sensor.
2. Check PCV hose connection.

Is intake air leakage detected?

- YES >> Repair or replace malfunctioning part.
- NO >> GO TO 3.

### 3.CHECK A/F SENSOR 1 CIRCUIT

1. Turn ignition switch OFF.
2. Disconnect corresponding A/F sensor 1 harness connector.
3. Disconnect ECM harness connector.
4. Check the continuity between A/F sensor 1 harness connector and ECM harness connector.

# P0171, P0174 FUEL INJECTION SYSTEM FUNCTION

< DTC/CIRCUIT DIAGNOSIS >

[VK56VD FOR USA AND CANADA]

| DTC   | A/F sensor 1 |           |          | ECM       |          | Continuity |
|-------|--------------|-----------|----------|-----------|----------|------------|
|       | Bank         | Connector | Terminal | Connector | Terminal |            |
| P0171 | 1            | F23       | 3        | F111      | 88       | Existed    |
|       |              |           | 4        |           | 90       |            |
|       |              |           | 6        |           | 94       |            |
| P0174 | 2            | F24       | 3        |           | 78       |            |
|       |              |           | 4        |           | 80       |            |
|       |              |           | 6        |           | 74       |            |

5. Check the continuity between A/F sensor 1 harness connector and ground, or ECM harness connector and ground.

| DTC   | A/F sensor 1 |           |          | ECM       |          | Continuity | Continuity  |
|-------|--------------|-----------|----------|-----------|----------|------------|-------------|
|       | Bank         | Connector | Terminal | Connector | Terminal |            |             |
| P0171 | 1            | F23       | 3        | F111      | 88       | Existed    | Not existed |
|       |              |           | 4        |           | 90       |            |             |
|       |              |           | 6        |           | 94       |            |             |
| P0174 | 2            | F24       | 3        |           | 78       |            |             |
|       |              |           | 4        |           | 80       |            |             |
|       |              |           | 6        |           | 74       |            |             |

6. Also check harness for short to power.

Is the inspection result normal?

YES >> GO TO 4.

NO >> Repair open circuit, short to ground or short to power in harness or connectors.

## 4. CHECK FUEL PRESSURE

Check fuel pressure. Refer to [EC-1127, "Work Procedure"](#).

Is the inspection result normal?

YES >> GO TO 6.

NO >> GO TO 5.

## 5. DETECT MALFUNCTIONING PART

Check fuel hoses and fuel tubes for clogging.

Is the inspection result normal?

YES >> Replace "fuel filter and fuel pump assembly". Refer to [FL-6, "Removal and Installation"](#).

NO >> Repair or replace malfunctioning part.

## 6. CHECK MASS AIR FLOW SENSOR

Ⓟ WITH CONSULT

1. Install all removed parts.

2. Check "MASS AIR FLOW" in "DATA MONITOR" mode with CONSULT.

For specification, refer to [EC-1556, "Mass Air Flow Sensor"](#).

Ⓢ WITH GST

1. Install all removed parts.

2. Check mass air flow sensor signal in Service \$01 with GST.

For specification, refer to [EC-1556, "Mass Air Flow Sensor"](#).

Is the measurement value within the specification?

YES >> GO TO 7.

NO >> Check connectors for rusted terminals or loose connections in the mass air flow sensor circuit or grounds. Refer to [EC-1199, "Diagnosis Procedure"](#).

## 7. CHECK FUNCTION OF FUEL INJECTOR

# P0171, P0174 FUEL INJECTION SYSTEM FUNCTION

[VK56VD FOR USA AND CANADA]

## < DTC/CIRCUIT DIAGNOSIS >

### ④ WITH CONSULT

1. Start engine.
2. Perform "POWER BALANCE" in "ACTIVE TEST" mode with CONSULT.
3. Check that each circuit produces a momentary engine speed drop.

### ⊗ WITHOUT CONSULT

1. Start engine and let it idle.
2. Listen to each fuel injector operating sound.

**Clicking sound should be heard.**

### Is the inspection result normal?

YES >> GO TO 8.

NO >> Perform trouble diagnosis for fuel injector, refer to [EC-1517, "Diagnosis Procedure"](#).

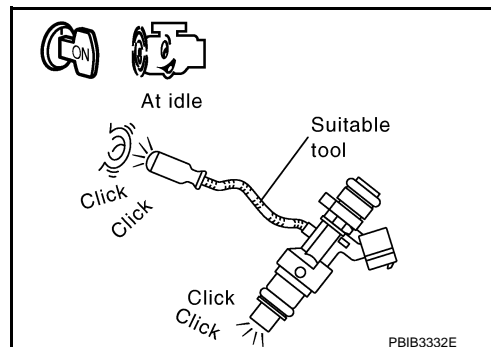

## 8. CHECK INTERMITTENT INCIDENT

Refer to [GI-44, "Intermittent Incident"](#).

### Is the inspection result normal?

YES >> Replace fuel injector. Refer to [EM-197, "Removal and Installation"](#).

NO >> Repair or replace malfunctioning part.

A

EC

C

D

E

F

G

H

I

J

K

L

M

N

O

P

# P0172, P0175 FUEL INJECTION SYSTEM FUNCTION

< DTC/CIRCUIT DIAGNOSIS >

[VK56VD FOR USA AND CANADA]

## P0172, P0175 FUEL INJECTION SYSTEM FUNCTION

### DTC Logic

INFOID:000000007187538

#### DTC DETECTION LOGIC

With the Air/Fuel Mixture Ratio Self-Learning Control, the actual mixture ratio can be brought closely to the theoretical mixture ratio based on the mixture ratio feedback signal from A/F sensor 1. The ECM calculates the necessary compensation to correct the offset between the actual and the theoretical ratios.

In case the amount of the compensation value is extremely large (the actual mixture ratio is too rich), the ECM judges the condition as the fuel injection system malfunction and illuminates the MIL (2 trip detection logic).

| Sensor       | Input signal to ECM  | ECM function           | Actuator      |
|--------------|--|------------------------|---------------|
| A/F sensor 1 | Density of oxygen in exhaust gas (Mixture ratio feedback signal) | Fuel injection control | Fuel injector |

| DTC No. | Trouble diagnosis name (Trouble diagnosis content)         | DTC detecting condition  | Possible cause  |
|---------|--|--|---|
| P0172   | FUEL SYS-RICH-B1 [Fuel injection system too rich (bank 1)] | <ul style="list-style-type: none"><li>Fuel injection system does not operate properly.</li><li>The amount of mixture ratio compensation is too large. (The mixture ratio is too rich.)</li></ul> | <ul style="list-style-type: none"><li>A/F sensor 1</li><li>Fuel injector</li><li>Exhaust gas leakage</li><li>Incorrect fuel pressure</li><li>Mass air flow sensor</li></ul> |
| P0175   | FUEL SYS-RICH-B2 [Fuel injection system too rich (bank 2)] |  |   |

#### DTC CONFIRMATION PROCEDURE

##### 1. PRECONDITIONING

If DTC Confirmation Procedure has been previously conducted, always perform the following procedure before conducting the next test.

- Turn ignition switch OFF and wait at least 10 seconds.
- Turn ignition switch ON.
- Turn ignition switch OFF and wait at least 10 seconds.

>> GO TO 2.

##### 2. PERFORM DTC CONFIRMATION PROCEDURE-I

- Clear the mixture ratio self-learning value. Refer to [EC-1126, "Work Procedure"](#).
- Start engine.

Is it difficult to start engine?

YES >> GO TO 3.

NO >> GO TO 4.

##### 3. RESTART ENGINE

If it is difficult to start engine, the fuel injection system has a malfunction, too.

Crank engine while depressing accelerator pedal.

#### NOTE:

When depressing accelerator pedal three fourths (3/4) or more, the control system does not start the engine. Do not depress accelerator pedal too much.

Does engine start?

YES >> Proceed to [EC-1269, "Diagnosis Procedure"](#).

NO >> Remove spark plugs and check for fouling, etc. Refer to [EM-186, "Exploded View"](#).

##### 4. PERFORM DTC CONFIRMATION PROCEDURE-II

- Keep engine idle for at least 5 minutes.
- Check 1st trip DTC.

Is 1st trip DTC detected?

YES >> Proceed to [EC-1269, "Diagnosis Procedure"](#).

# P0172, P0175 FUEL INJECTION SYSTEM FUNCTION

[VK56VD FOR USA AND CANADA]

< DTC/CIRCUIT DIAGNOSIS >

NO >> GO TO 5.

## 5. PERFORM DTC CONFIRMATION PROCEDURE-III

1. Turn ignition switch OFF and wait at least 10 seconds.
2. Turn ignition switch ON.
3. Turn ignition switch OFF and wait at least 10 seconds.
4. Start engine.
5. Maintain the following conditions for at least 10 consecutive minutes.  
**Hold the accelerator pedal as steady as possible.**

|               |                             |
|---------------|-----------------------------|
| Vehicle speed | 50 - 120 km/h (31 - 75 MPH) |
|---------------|-----------------------------|

### CAUTION:

**Always drive vehicle at a safe speed.**

6. Check 1st trip DTC.

Is 1st trip DTC detected?

- YES >> Proceed to [EC-1269, "Diagnosis Procedure"](#).  
NO >> INSPECTION END

## Diagnosis Procedure

INFOID:000000007187539

### 1. CHECK EXHAUST GAS LEAKAGE

1. Start engine and run it at idle.
2. Listen for an exhaust gas leakage before three way catalyst (manifold).

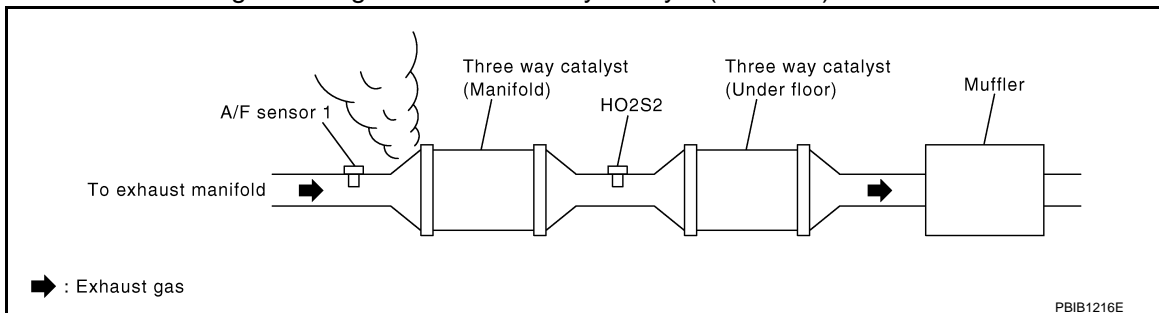

Is exhaust gas leakage detected?

- YES >> Repair or replace malfunctioning part.  
NO >> GO TO 2.

### 2. CHECK FOR INTAKE AIR LEAKAGE

Listen for an intake air leakage after the mass air flow sensor.

Is intake air leakage detected?

- YES >> Repair or replace malfunctioning part.  
NO >> GO TO 3.

### 3. CHECK A/F SENSOR 1 CIRCUIT

1. Turn ignition switch OFF.
2. Disconnect corresponding A/F sensor 1 harness connector.
3. Disconnect ECM harness connector.
4. Check the continuity between A/F sensor 1 harness connector and ECM harness connector.

# P0172, P0175 FUEL INJECTION SYSTEM FUNCTION

< DTC/CIRCUIT DIAGNOSIS >

[VK56VD FOR USA AND CANADA]

| DTC   | A/F sensor 1 |           |          | ECM       |          | Continuity |
|-------|--------------|-----------|----------|-----------|----------|------------|
|       | Bank         | Connector | Terminal | Connector | Terminal |            |
| P0171 | 1            | F23       | 3        | F111      | 88       | Existed    |
|       |              |           | 4        |           | 90       |            |
|       |              |           | 6        |           | 94       |            |
| P0174 | 2            | F24       | 3        |           | 78       |            |
|       |              |           | 4        |           | 80       |            |
|       |              |           | 6        |           | 74       |            |

5. Check the continuity between A/F sensor 1 harness connector and ground, or ECM harness connector and ground.

| DTC   | A/F sensor 1 |           |          | ECM       |          | Continuity | Continuity  |
|-------|--------------|-----------|----------|-----------|----------|------------|-------------|
|       | Bank         | Connector | Terminal | Connector | Terminal |            |             |
| P0171 | 1            | F23       | 3        | F111      | 88       | Existed    | Not existed |
|       |              |           | 4        |           | 90       |            |             |
|       |              |           | 6        |           | 94       |            |             |
| P0174 | 2            | F24       | 3        |           | 78       |            |             |
|       |              |           | 4        |           | 80       |            |             |
|       |              |           | 6        |           | 74       |            |             |

6. Also check harness for short to power.

Is the inspection result normal?

YES >> GO TO 4.

NO >> Repair open circuit, short to ground or short to power in harness or connectors.

## 4. CHECK FUEL PRESSURE

Check fuel pressure. Refer to [EC-1127, "Work Procedure"](#).

Is the inspection result normal?

YES >> GO TO 5.

NO >> Replace fuel filter and fuel pump assembly". Refer to [FL-6, "Removal and Installation"](#).

## 5. CHECK MASS AIR FLOW SENSOR

Ⓟ WITH CONSULT

1. Install all removed parts.
2. Check "MASS AIR FLOW" in "DATA MONITOR" mode with CONSULT.  
For specification, refer to [EC-1556, "Mass Air Flow Sensor"](#).

Ⓢ WITH GST

1. Install all removed parts.
2. Check mass air flow sensor signal in "Service \$01" with GST.  
For specification, refer to [EC-1556, "Mass Air Flow Sensor"](#).

Is the measurement value within the specification?

YES >> GO TO 6.

NO >> Check connectors for rusted terminals or loose connections in the mass air flow sensor circuit or grounds. Refer to [EC-1199, "Diagnosis Procedure"](#).

## 6. CHECK FUNCTION OF FUEL INJECTOR

Ⓟ WITH CONSULT

1. Start engine.
2. Perform "POWER BALANCE" in "ACTIVE TEST" mode with CONSULT.
3. Check that each circuit produces a momentary engine speed drop.

ⓧ WITHOUT CONSULT

1. Start engine and let it idle.

# P0172, P0175 FUEL INJECTION SYSTEM FUNCTION

[VK56VD FOR USA AND CANADA]

< DTC/CIRCUIT DIAGNOSIS >

2. Listen to each fuel injector operating sound.

**Clicking sound should be heard.**

Is the inspection result normal?

YES >> GO TO 7.

NO >> Perform trouble diagnosis for fuel injector, refer to [EC-1517. "Diagnosis Procedure"](#).

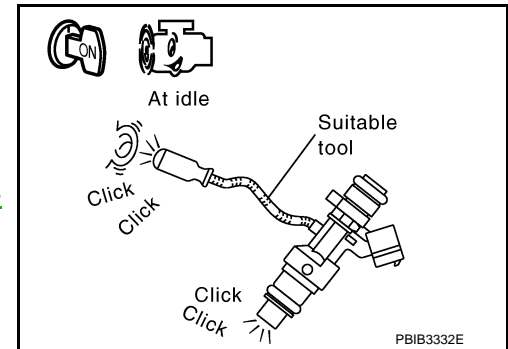

## 7. CHECK INTERMITTENT INCIDENT

Refer to [GI-44. "Intermittent Incident"](#).

Is the inspection result normal?

YES >> Replace fuel injector. Refer to [EM-197. "Removal and Installation"](#).

NO >> Repair or replace malfunctioning part.

A

EC

C

D

E

F

G

H

I

J

K

L

M

N

O

P

# P0181 FTT SENSOR

< DTC/CIRCUIT DIAGNOSIS >

[VK56VD FOR USA AND CANADA]

## P0181 FTT SENSOR

### DTC Logic

INFOID:000000007187540

### DTC DETECTION LOGIC

| DTC No. | Trouble diagnosis name<br>(Trouble diagnosis content)                                | DTC detecting condition |  | Possible cause   |
|---------|--|-------------------------|--|--|
| P0181   | FTT SENSOR<br>[Fuel tank temperature (FTT)<br>sensor circuit range/perfor-<br>mance] | A)                      | Rationally incorrect voltage from the sensor is sent to ECM, compared with the voltage signals from engine coolant temperature sensor and intake air temperature sensor.   | <ul style="list-style-type: none"><li>• Harness or connectors (The FTT sensor circuit is open or shorted)</li><li>• Fuel tank temperature sensor</li><li>• Combination meter</li></ul> |
|         |  | B)                      | The comparison result of signals transmitted to ECM from each temperature sensor (IAT sensor, ECT sensor, EOT sensor, and FTT sensor) shows that the voltage signal of the FTT sensor is higher/lower than that of other temperature sensors when the engine is started with its cold state. | <ul style="list-style-type: none"><li>• Harness or connectors (The FTT sensor circuit is open or shorted)</li><li>• Fuel tank temperature sensor</li></ul>                             |

### DTC CONFIRMATION PROCEDURE

#### 1.INSPECTION START

#### Is it necessary to erase permanent DTC?

- YES >> GO TO 7.  
NO >> GO TO 2.

#### 2.PRECONDITIONING

If DTC CONFIRMATION PROCEDURE has been previously conducted, always perform the following procedure before conducting the next test.

1. Turn ignition switch OFF and wait at least 10 seconds.
2. Turn ignition switch ON.
3. Turn ignition switch OFF and wait at least 10 seconds.

>> GO TO 3.

#### 3.PERFORM DTC CONFIRMATION PROCEDURE FOR MALFUNCTION A-I

1. Turn ignition switch ON and wait at least 10 seconds.
2. Check 1st trip DTC.

#### Is 1st trip DTC detected?

- YES >> Proceed to [EC-1274, "Diagnosis Procedure"](#).  
NO >> GO TO 4.

#### 4.CHECK ENGINE COOLANT TEMPERATURE

##### WITH CONSULT

1. Select "COOLAN TEMP/S" in "DATA MONITOR" with CONSULT.
2. Check "COOLAN TEMP/S" value.

##### WITH GST

Follow the procedure "With CONSULT" above.

#### "COOLAN TEMP/S" less than 60°C (140°F)?

- YES >> INSPECTION END  
NO >> GO TO 5.

#### 5.PERFORM DTC CONFIRMATION PROCEDURE-II

##### WITH CONSULT

1. Cool engine down until "COOLAN TEMP/S" is less than 60°C (140°F).



< DTC/CIRCUIT DIAGNOSIS >

2. Wait at least 10 seconds.
3. Check 1st trip DTC.

 WITH GST

Follow the procedure "With CONSULT" above.

Is 1st trip DTC detected?

- YES >> Proceed to [EC-1274, "Diagnosis Procedure"](#).
- NO >> GO TO 6.

**6. PERFORM COMPONENT FUNCTION CHECK (FOR MALFUNCTION B)**

Perform component function check. Refer to [EC-1273, "Component Function Check"](#).

**NOTE:**

Use the component function check to check the overall function of the FTT sensor circuit. During this check, a 1st trip DTC might not be confirmed.

Is the inspection result normal?

- YES >> INSPECTION END
- NO >> Proceed to [EC-1274, "Diagnosis Procedure"](#).

**7. PRECONDITIONING**

If DTC CONFIRMATION PROCEDURE has been previously conducted, always perform the following procedure before conducting the next test.

1. Turn ignition switch OFF and wait at least 10 seconds.
2. Turn ignition switch ON.
3. Turn ignition switch OFF and wait at least 10 seconds.

**TESTING CONDITION:**

- Before performing the following procedure, do not add fuel.
- Before performing the following procedure, check that fuel level is between 1/4 and 4/4.
- Before performing the following procedure, confirm that battery voltage is 11 V or more at idle.

>> GO TO 8.

**8. PERFORM DTC CONFIRMATION PROCEDURE B**

1. Start engine and let it idle for 60 minutes.
2. Move the vehicle to a cool place.

**NOTE:**

Cool the vehicle in an environment of ambient air temperature between -10°C (14°F) and 35°C (95°F).

3. Turn ignition switch OFF and soak the vehicle for 12 hours.

**CAUTION:**

**Never turn ignition switch ON during soaking.**

**NOTE:**

The vehicle must be cooled with the hood open.

4. Start engine and let it idle for 5 minutes or more.

**CAUTION:**

**Never turn ignition switch OFF during idling.**

5. Check 1st trip DTC.

Is 1st trip DTC detected?

- YES >> Proceed to [EC-1274, "Diagnosis Procedure"](#).
- NO >> INSPECTION END

**Component Function Check**

INFOID:000000007202570

**1. CHECK FUEL TANK TEMPERATURE SENSOR**

1. Turn ignition switch OFF.
2. Disconnect "fuel level sensor unit and fuel pump (main)" harness connector.
3. Remove fuel level sensor unit. Refer to [FL-5, "Exploded View"](#).

# P0181 FTT SENSOR

[VK56VD FOR USA AND CANADA]

## < DTC/CIRCUIT DIAGNOSIS >

4. Check resistance between “fuel level sensor unit and fuel pump (main)” terminals by heating with hot water as shown in the figure.

| Terminals | Condition             | Resistance (kΩ) |             |
|-----------|-----------------------|-----------------|-------------|
| 4 and 5   | Temperature [°C (°F)] | 20 (68)         | 2.3 - 2.7   |
|           |                       | 50 (122)        | 0.79 - 0.90 |

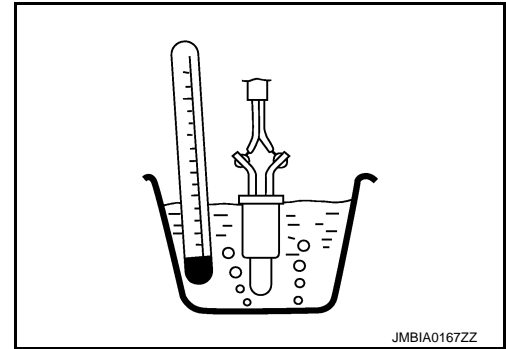

Is the inspection result normal?

- YES >> GO TO 2.  
NO >> Proceed to [EC-1274, "Diagnosis Procedure"](#).

## 2.CHECK INTERMITTENT INCIDENT

Refer to [GI-44, "Intermittent Incident"](#).

Is the inspection result normal?

- YES >> INSPECTION END  
NO >> Proceed to [EC-1274, "Diagnosis Procedure"](#).

## Diagnosis Procedure

INFOID:000000007187541

### 1.INSPECTION START

Confirm the detected malfunction (A or B). Refer to [EC-1272, "DTC Logic"](#).

Which malfunction is detected?

- YES >> GO TO 2.  
NO >> GO TO 7.

### 2.CHECK DTC WITH COMBINATION METER

Check DTC with combination meter. Refer to [MWI-31, "CONSULT Function"](#).

Is the inspection result normal?

- YES >> GO TO 3.  
NO >> Proceed to [EC-1273, "Component Function Check"](#).

### 3.CHECK FUEL TANK TEMPERATURE SENSOR POWER SUPPLY CIRCUIT

1. Turn ignition switch OFF.
2. Disconnect “fuel level sensor unit and fuel pump (main)” harness connector.
3. Turn ignition switch ON.
4. Check the voltage between “fuel level sensor unit and fuel pump (main)” harness connector and ground.

| Fuel level sensor unit and fuel pump (main) |          | Ground | Voltage (V) |
|---|----------|--------|-------------|
| Connector                                   | Terminal |        |             |
| B241  | 4        | Ground | Approx. 5   |

Is the inspection result normal?

- YES >> GO TO 5.  
NO >> GO TO 4.

### 4.DETECT MALFUNCTIONING PART

Check the following.

- Harness for open or short between ECM and “fuel level sensor unit and fuel pump (main)”
- Loose or poor connection for each connector and harness

>> Repair open circuit, short to ground or short to power in harness or connector.

### 5.CHECK FUEL TANK TEMPERATURE SENSOR GROUND CIRCUIT FOR OPEN AND SHORT

1. Turn ignition switch OFF.
2. Disconnect “combination meter” harness connector.

# P0181 FTT SENSOR

[VK56VD FOR USA AND CANADA]

## < DTC/CIRCUIT DIAGNOSIS >

3. Check the continuity between “fuel level sensor unit and fuel pump (main)” harness connector and “combination meter” harness connector.

| Fuel level sensor unit and fuel pump (main) |          | Combination meter |          | Continuity |
|---|----------|-------------------|----------|------------|
| Connector                                   | Terminal | Connector         | Terminal |            |
| B241  | 5        | M53               | 24       | Existed    |

4. Also check harness for short to ground and short to power.

Is the inspection result normal?

YES >> GO TO 7.

NO >> GO TO 6.

## 6. DETECT MALFUNCTIONING PART

Check the following.

- Harness for open or short between “fuel level sensor unit and fuel pump (main)” and “combination meter”
- Loose or poor connection for each connector and harness

>> Repair open circuit, short to ground or short to power in harness or connector.

## 7. CHECK FUEL TANK TEMPERATURE SENSOR

Check FTT sensor. Refer to [EC-1275. "Component Inspection \(Fuel Tank Temperature Sensor\)"](#).

Is the inspection result normal?

YES >> GO TO 8.

NO >> Replace fuel level sensor unit and fuel pump (main). Refer to [FL-6. "Removal and Installation"](#).

## 8. CHECK INTERMITTENT INCIDENT

Refer to [GI-44. "Intermittent Incident"](#).

>> INSPECTION END

## Component Inspection (Fuel Tank Temperature Sensor)

INFOID:000000007187542

### 1. CHECK FUEL TANK TEMPERATURE SENSOR

1. Turn ignition switch OFF.
2. Disconnect “fuel level sensor unit and fuel pump (main)” harness connector.
3. Remove fuel level sensor unit. Refer to [FL-5. "Exploded View"](#).
4. Check resistance between “fuel level sensor unit and fuel pump (main)” terminals by heating with hot water as shown in the figure.

| Terminals | Condition             | Resistance (kΩ) |             |
|-----------|-----------------------|-----------------|-------------|
| 4 and 5   | Temperature [°C (°F)] | 20 (68)         | 2.3 - 2.7   |
|           |                       | 50 (122)        | 0.79 - 0.90 |

Is the inspection result normal?

YES >> INSPECTION END

NO >> Replace “fuel level sensor unit and fuel pump (main)”. Refer to [FL-5. "Exploded View"](#).

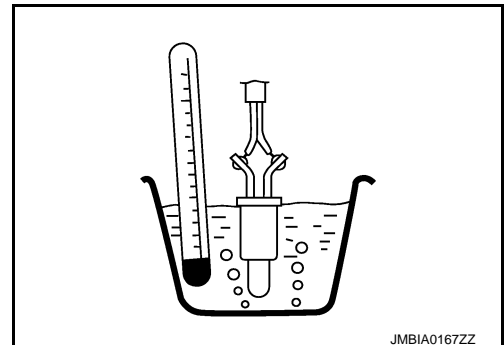

JMBIA0167ZZ

# P0182, P0183 FTT SENSOR

< DTC/CIRCUIT DIAGNOSIS >

[VK56VD FOR USA AND CANADA]

## P0182, P0183 FTT SENSOR

### DTC Logic

INFOID:000000007187543

### DTC DETECTION LOGIC

| DTC No. | Trouble diagnosis name<br>(Trouble diagnosis content)                | DTC detecting condition                                     | Possible cause  |
|---------|--|---|---|
| P0182   | FTT SEN/CIRCUIT<br>(Fuel tank temperature sensor circuit low input)  | An excessively low voltage from the sensor is sent to ECM.  | <ul style="list-style-type: none"><li>• Harness or connectors<br/>(The FTT sensor circuit is open or shorted.)</li><li>• Fuel tank temperature sensor</li><li>• Combination meter</li></ul> |
| P0183   | FTT SEN/CIRCUIT<br>(Fuel tank temperature sensor circuit high input) | An excessively high voltage from the sensor is sent to ECM. |   |

### DTC CONFIRMATION PROCEDURE

#### 1. PRECONDITIONING

If DTC Confirmation Procedure has been previously conducted, always perform the following procedure before conducting the next test.

1. Turn ignition switch OFF and wait at least 10 seconds.
2. Turn ignition switch ON.
3. Turn ignition switch OFF and wait at least 10 seconds.

>> GO TO 2.

#### 2. PERFORM DTC CONFIRMATION PROCEDURE

1. Turn ignition switch ON and wait at least 5 seconds.
2. Check 1st trip DTC.

Is 1st trip DTC detected?

- YES >> Proceed to [EC-1276. "Diagnosis Procedure"](#).  
NO >> INSPECTION END

### Diagnosis Procedure

INFOID:000000007187544

#### 1. CHECK DTC WITH COMBINATION METER

Refer to [MWI-31. "CONSULT Function"](#).

Is the inspection result normal?

- YES >> GO TO 2.  
NO >> Proceed to [MWI-62. "Component Function Check"](#).

#### 2. CHECK FUEL TANK TEMPERATURE SENSOR POWER SUPPLY CIRCUIT

1. Turn ignition switch OFF.
2. Disconnect "fuel level sensor unit and fuel pump (main)" harness connector.
3. Turn ignition switch ON.
4. Check the voltage between "fuel level sensor unit and fuel pump (main)" harness connector and ground.

| Fuel level sensor unit and fuel pump (main) |          | Ground | Voltage (V) |
|---|----------|--------|-------------|
| Connector                                   | Terminal |        |             |
| B241  | 4        | Ground | Approx. 5   |

Is the inspection result normal?

- YES >> GO TO 4.  
NO >> GO TO 3.

#### 3. DETECT MALFUNCTIONING PART

# P0182, P0183 FTT SENSOR

[VK56VD FOR USA AND CANADA]

## < DTC/CIRCUIT DIAGNOSIS >

Check the following.

- Harness for open or short between ECM and “fuel level sensor unit and fuel pump (main)”
- Loose or poor connection for each connector and harness

>> Repair open circuit, short to ground or short to power in harness or connector.

### 4. CHECK FUEL TANK TEMPERATURE SENSOR GROUND CIRCUIT FOR OPEN AND SHORT

1. Turn ignition switch OFF.
2. Disconnect combination meter harness connector.
3. Check the continuity between “fuel level sensor unit and fuel pump (main)” harness connector and “combination meter” harness connector.

| Fuel level sensor unit and fuel pump (main) |          | Combination meter |          | Continuity |
|---|----------|-------------------|----------|------------|
| Connector                                   | Terminal | Connector         | Terminal |            |
| B241  | 5        | M53               | 24       | Existed    |

4. Also check harness for short to ground and short to power.

Is the inspection result normal?

YES >> GO TO 6.

NO >> GO TO 5.

### 5. DETECT MALFUNCTIONING PART

Check the following.

- Harness for open or short between “fuel level sensor unit and fuel pump (main)” and “combination meter”
- Loose or poor connection for each connector and harness

>> Repair open circuit, short to ground - short to power in harness or connector.

### 6. CHECK FUEL TANK TEMPERATURE SENSOR

Refer to [EC-1277, "Component Inspection \(Fuel Tank Temperature Sensor\)"](#).

Is the inspection result normal?

YES >> GO TO 7.

NO >> Replace “fuel level sensor unit and fuel pump”. Refer to [FL-6, "Removal and Installation"](#).

### 7. CHECK INTERMITTENT INCIDENT

Refer to [GI-44, "Intermittent Incident"](#).

>> INSPECTION END

## Component Inspection (Fuel Tank Temperature Sensor)

INFOID:000000007187545

### 1. CHECK FUEL TANK TEMPERATURE SENSOR

1. Turn ignition switch OFF.
2. Disconnect “fuel level sensor unit and fuel pump (main)” harness connector.
3. Remove fuel level sensor unit. Refer to [FL-5, "Exploded View"](#).
4. Check resistance between “fuel level sensor unit and fuel pump (main)” terminals by heating with hot water as shown in the figure.

| Terminals | Condition             | Resistance (kΩ) |
|-----------|-----------------------|-----------------|
| 4 and 5   | Temperature [°C (°F)] | 2.3 - 2.7       |
|           |                       | 0.79 - 0.90     |

Is the inspection result normal?

YES >> INSPECTION END

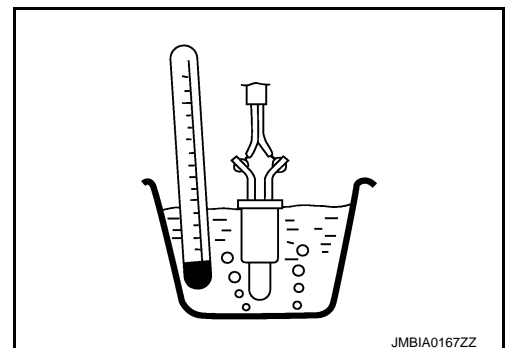

JMBIA0167ZZ

## P0182, P0183 FTT SENSOR

< DTC/CIRCUIT DIAGNOSIS >

[VK56VD FOR USA AND CANADA]

---

NO >> Replace "fuel level sensor unit and fuel pump (main)". Refer to [FL-5. "Exploded View"](#).

# P0190, P0192, P0193 FRP SENSOR

< DTC/CIRCUIT DIAGNOSIS >

[VK56VD FOR USA AND CANADA]

## P0190, P0192, P0193 FRP SENSOR

### DTC Logic

INFOID:000000007187546

### DTC DETECTION LOGIC

| DTC No. | Trouble diagnosis name                                     | DTC detecting condition  | Possible cause  |
|---------|--|--|---|
| P0190   | Fuel rail pressure sensor circuit low input and high input | Signal voltage from the fuel rail pressure sensor remains at more than 4.84 V / less than 0.2 V for 5 seconds or more. | <ul style="list-style-type: none"><li>• Harness or connectors (Fuel rail pressure sensor circuit is open or shorted.) (Power steering pressure sensor circuit is open or shorted.) (Low fuel pressure sensor circuit is open or shorted.) (Engine oil pressure sensor circuit is open or shorted.)</li><li>• Fuel rail pressure sensor</li><li>• Power steering pressure sensor</li><li>• Low fuel pressure sensor</li><li>• Engine oil pressure sensor</li></ul> |
| P0192   | Fuel rail pressure sensor circuit low input                | Signal voltage from the fuel rail pressure sensor remains at less than 0.37 V for 5 seconds or more.                   |   |
| P0193   | Fuel rail pressure sensor circuit high input               | Signal voltage from the fuel rail pressure sensor remains at more than 3.73 V for 5 seconds or more.                   |   |

### DTC CONFIRMATION PROCEDURE

#### 1. PRECONDITIONING

If DTC Confirmation Procedure has been previously conducted, always perform the following procedure before conducting the next test.

1. Turn ignition switch OFF and wait at least 10 seconds.
2. Turn ignition switch ON.
3. Turn ignition switch OFF and wait at least 10 seconds.

#### TESTING CONDITION:

Before performing the following procedure, confirm that battery voltage is 11 V or more at idle.

>> GO TO 2.

#### 2. PERFORM DTC CONFIRMATION PROCEDURE

1. Start the engine ON and wait at least 60 seconds.
2. Check DTC or 1st trip DTC.

Is DTC or 1st trip DTC detected?

- YES >> Proceed to [EC-1279, "Diagnosis Procedure"](#).  
NO >> INSPECTION END

### Diagnosis Procedure

INFOID:000000007187547

#### NOTE:

Turning the ignition switch ON with FRP sensor harness connector disconnected causes ECM to detect DTC P0190. Be sure to erase the DTC when the diagnosis procedure.

#### 1. CHECK FRP SENSOR POWER SUPPLY-I

1. Turn ignition switch OFF.
2. Disconnect FRP sensor connector.
3. Turn ignition switch ON.
4. Check the voltage between FRP sensor harness connector terminals.

| Connector | FRP sensor |   | Voltage (Approx.) |
|-----------|------------|---|-------------------|
|           | +          | - |                   |
| F6        | 1          | 3 | 5 V               |

Inspection result normal?

# P0190, P0192, P0193 FRP SENSOR

< DTC/CIRCUIT DIAGNOSIS >

[VK56VD FOR USA AND CANADA]

- YES >> GO TO 6.
- NO >> GO TO 2.

## 2.CHECK FRP SENSOR POWER SUPPLY-II

Check the voltage between FRP sensor harness connector and the ground.

| +          |          | -      | Voltage<br>(Approx.) |
|------------|----------|--------|----------------------|
| FRP sensor |          |        |                      |
| Connector  | Terminal |        |                      |
| F6         | 1        | Ground | 5 V                  |

Is inspection result normal?

- YES >> GO TO 4.
- NO >> GO TO 3.

## 3.CHECK SENSOR POWER SUPPLY CIRCUIT

1. Turn ignition switch OFF.
2. Disconnect ECM harness connector.
3. Check harness connector for short to power and short to ground, between the following terminals.

| ECM       |          | Sensor                         |           |          |
|-----------|----------|--------------------------------|-----------|----------|
| Connector | Terminal | Name                           | Connector | Terminal |
| F110      | 27       | Power steering pressure sensor | F35       | 3        |
|           |          | Low fuel pressure sensor       | F39       | 3        |
|           | 28       | FRP sensor                     | F6        | 1        |
|           |          | Engine oil pressure sensor     | F32       | 3        |

Is inspection result normal?

- YES >> Perform the trouble diagnosis for power supply circuit. Refer to [EC-1149. "Diagnosis Procedure"](#).
- NO >> Repair or replace error-detected parts.

## 4.CHECK FRP SENSOR GROUND CIRCUIT

1. Turn ignition switch OFF.
2. Disconnect ECM harness connector.
3. Check the continuity between FRP sensor harness connector and ECM harness connector.

| +          |          | -         |          | Continuity |
|------------|----------|-----------|----------|------------|
| FRP sensor |          | ECM       |          |            |
| Connector  | Terminal | Connector | Terminal |            |
| F6         | 3        | F110      | 40       | Existed    |

Is inspection result normal?

- YES >> GO TO 5.
- NO >> Repair or replace error-detected parts.

## 5.CHECK ECM GROUND CIRCUIT

Check the continuity between ECM harness connector and the ground.



# P0190, P0192, P0193 FRP SENSOR

< DTC/CIRCUIT DIAGNOSIS >

[VK56VD FOR USA AND CANADA]

| ECM       |          | Ground | Continuity |
|-----------|----------|--------|------------|
| Connector | Terminal |        |            |
| F110      | 10       | Ground | Existed    |
| M160      | 114      |        |            |
|           | 115      |        |            |
|           | 174      |        |            |
|           | 175      |        |            |

Is inspection result normal?

- YES >> Check intermittent incident. Refer to [GI-44, "Intermittent Incident"](#).  
 NO >> Repair or replace error-detected parts.

## 6.CHECK FRP SENSOR SIGNAL CIRCUIT

- Turn ignition switch OFF.
- Disconnect ECM harness connector.
- Check the continuity between FRP sensor harness connector and ECM harness connector.

| +          |          | -         |          | Continuity |
|------------|----------|-----------|----------|------------|
| FRP sensor |          | ECM       |          |            |
| Connector  | Terminal | Connector | Terminal |            |
| F6         | 2        | F110      | 31       | Existed    |

- Also check harness for short to ground and to power.

Is inspection result normal?

- YES >> GO TO 7.  
 NO >> Repair or replace error-detected parts.

## 7.CHECK FRP SENSOR

Refer to [EC-1281, "Component Inspection \(Fuel Rail Pressure Sensor\)"](#).

Is inspection result normal?

- YES >> Check intermittent incident. Refer to [GI-44, "Intermittent Incident"](#).  
 NO >> Repair or replace error-detected parts.

## Component Inspection (Fuel Rail Pressure Sensor)

INFOID:000000007187548

### 1.CHECK FRP SENSOR

#### Ⓜ WITH CONSULT

- Turn ignition switch OFF.
- Reconnect harness connector disconnected.
- Start the engine.
- Select "DATA MONITOR" mode with CONSULT.
- Check that the "FUEL PRES SEN V" indication.

| Monitor Item    | Condition   | Values/Status  |
|-----------------|---|----------------|
| FUEL PRES SEN V | Engine speed: Idle  | 820 – 1,220 mV |
|                 | Engine speed: Revving engine from idle to 4,000 rpm quickly | 820 – 3,060 mV |

#### Ⓧ WITHOUT CONSULT

- Turn ignition switch OFF.
- Reconnect harness connector disconnected.
- Start the engine.
- Check FRP sensor signal voltage.

# P0190, P0192, P0193 FRP SENSOR

< DTC/CIRCUIT DIAGNOSIS >

[VK56VD FOR USA AND CANADA]

| +         |          | -         |          | Condition   | Value<br>(Approx.) |
|-----------|----------|-----------|----------|---|--------------------|
| ECM       |          |           |          |   |                    |
| Connector | Terminal | Connector | Terminal |   |                    |
| F110      | 31       | F110      | 40       | [Engine is running] <ul style="list-style-type: none"><li>• Warm-up condition</li><li>• Idle speed</li></ul>                                    | 0.82 – 1.22 V      |
|           |          |           |          | [Engine is running] <ul style="list-style-type: none"><li>• Warm-up condition</li><li>• Revving engine from idle to 4,000 rpm quickly</li></ul> | 0.82 – 3.06 V      |

Is the inspection result normal?

YES >> INSPECTION END.

NO >> Replace FRP sensor. Refer to [EM-197. "Exploded View"](#).

# P0191 FRP SENSOR

< DTC/CIRCUIT DIAGNOSIS >

[VK56VD FOR USA AND CANADA]

## P0191 FRP SENSOR

### DTC Logic

INFOID:000000007187549

### DTC DETECTION LOGIC

| DTC No. | Trouble diagnosis name    | DTC detecting condition  | Possible cause  |
|---------|---------------------------|--|---|
| P0191   | Fuel rail pressure sensor | Fuel rail pressure remains at more than 14.5 MPa (147.9 kg/cm <sup>2</sup> , 2102.5 psi) for 0.2 seconds or more during ignition ON. | <ul style="list-style-type: none"><li>• Harness or connectors<br/>(Fuel rail pressure sensor circuit is open or shorted.)<br/>(Power steering pressure sensor circuit is open or shorted.)<br/>(Low fuel pressure sensor circuit is open or shorted.)<br/>(Engine oil pressure sensor circuit is open or shorted.)</li><li>• Fuel rail pressure sensor</li><li>• Power steering pressure sensor</li><li>• Low fuel pressure sensor</li><li>• Engine oil pressure sensor</li></ul> |

### DTC CONFIRMATION PROCEDURE

#### 1. PRECONDITIONING

If DTC Confirmation Procedure has been previously conducted, always perform the following procedure before conducting the next test.

1. Turn ignition switch OFF and wait at least 10 seconds.
2. Turn ignition switch ON.
3. Turn ignition switch OFF and wait at least 10 seconds.

#### TESTING CONDITION:

Before performing the following procedure, confirm that battery voltage is 11 V or more at idle.

>> GO TO 2.

#### 2. PERFORM DTC CONFIRMATION PROCEDURE

1. Start the engine and warm it up to the normal operating temperature.  
**NOTE:**  
Warm up the engine until "COOLAN TEMP/S" on "DATA MONITOR" of CONSULT reaches at least 70°C (158°F).
2. Turn the ignition switch OFF and cool the engine until the engine coolant temperature reaches 35°C (95°F) or less.  
**CAUTION:**
  - The difference between air temperature and engine coolant temperature must be 5°C(90°F) or less.
  - Do not turn ignition switch ON.
3. Turn ignition switch ON and wait at least 60 seconds.
4. Check 1st trip DTC.

Is 1st trip DTC detected?

- YES >> Proceed to [EC-1283, "Diagnosis Procedure"](#).  
NO >> INSPECTION END

### Diagnosis Procedure

INFOID:000000007187550

#### NOTE:

Turning the ignition switch ON with FRP sensor harness connector disconnected causes ECM to detect DTC P0190. Be sure to erase the DTC when the diagnosis procedure.

#### 1. CHECK FRP SENSOR POWER SUPPLY-I

1. Turn ignition switch OFF.
2. Disconnect FRP sensor connector.
3. Turn ignition switch ON.

# P0191 FRP SENSOR

< DTC/CIRCUIT DIAGNOSIS >

[VK56VD FOR USA AND CANADA]

4. Check the voltage between FRP sensor harness connector terminals.

| FRP sensor |          |   | Voltage<br>(Approx.) |
|------------|----------|---|----------------------|
| Connector  | +        | - |                      |
|            | terminal |   |                      |
| F6         | 1        | 3 | 5 V                  |

Is inspection result normal?

- YES >> GO TO 6.  
NO >> GO TO 2.

## 2.CHECK FRP SENSOR POWER SUPPLY-II

Check the voltage between FRP sensor harness connector and the ground.

| +          |          | -      | Voltage<br>(Approx.) |
|------------|----------|--------|----------------------|
| FRP sensor |          |        |                      |
| Connector  | Terminal |        |                      |
| F6         | 1        | Ground | 5 V                  |

Is inspection result normal?

- YES >> GO TO 4.  
NO >> GO TO 3.

## 3.CHECK SENSOR POWER SUPPLY CIRCUIT

1. Turn ignition switch OFF.
2. Disconnect ECM harness connector.
3. Check harness connector for short to power and short to ground, between the following terminals.

| ECM       |          | Sensor                         |           |          |
|-----------|----------|--------------------------------|-----------|----------|
| Connector | Terminal | Name                           | Connector | Terminal |
| F110      | 27       | Power steering pressure sensor | F35       | 3        |
|           |          | Low fuel pressure sensor       | F39       | 3        |
|           | 28       | FRP sensor                     | F6        | 1        |
|           |          | Engine oil pressure sensor     | F32       | 3        |

Is inspection result normal?

- YES >> Perform the trouble diagnosis for power supply circuit. Refer to [EC-1149. "Diagnosis Procedure"](#).  
NO >> Repair or replace error-detected parts.

## 4.CHECK FRP SENSOR GROUND CIRCUIT

1. Turn ignition switch OFF.
2. Disconnect ECM harness connector.
3. Check the continuity between FRP sensor harness connector and ECM harness connector.

| +          |          | -         |          | Continuity |
|------------|----------|-----------|----------|------------|
| FRP sensor |          | ECM       |          |            |
| Connector  | Terminal | Connector | Terminal |            |
| F6         | 3        | F110      | 40       | Existed    |

Is inspection result normal?

- YES >> GO TO 5.  
NO >> Repair or replace error-detected parts.

## 5.CHECK ECM GROUND CIRCUIT

Check the continuity between ECM harness connector and the ground.

# P0191 FRP SENSOR

< DTC/CIRCUIT DIAGNOSIS >

[VK56VD FOR USA AND CANADA]

| ECM       |          | Ground | Continuity |
|-----------|----------|--------|------------|
| Connector | Terminal |        |            |
| F110      | 10       | Ground | Existed    |
| M160      | 114      |        |            |
|           | 115      |        |            |
|           | 174      |        |            |
|           | 175      |        |            |

Is inspection result normal?

- YES >> Check intermittent incident. Refer to [GI-44, "Intermittent Incident"](#).  
 NO >> Repair or replace error-detected parts.

## 6. CHECK FRP SENSOR SIGNAL CIRCUIT

- Turn ignition switch OFF.
- Disconnect ECM harness connector.
- Check the continuity between FRP sensor harness connector and ECM harness connector.

| +          |          | -         |          | Continuity |
|------------|----------|-----------|----------|------------|
| FRP sensor |          | ECM       |          |            |
| Connector  | Terminal | Connector | Terminal |            |
| F6         | 2        | F110      | 31       | Existed    |

- Also check harness for short to ground and to power.

Is inspection result normal?

- YES >> GO TO 7.  
 NO >> Repair or replace error-detected parts.

## 7. CHECK FRP SENSOR

Refer to [EC-1281, "Component Inspection \(Fuel Rail Pressure Sensor\)"](#).

Is inspection result normal?

- YES >> Check intermittent incident. Refer to [GI-44, "Intermittent Incident"](#).  
 NO >> Repair or replace error-detected parts.

## Component Inspection (Fuel Rail Pressure Sensor)

INFOID:000000007187551

### 1. CHECK FRP SENSOR

#### Ⓜ WITH CONSULT

- Turn ignition switch OFF.
- Reconnect harness connector disconnected.
- Start the engine.
- Select "DATA MONITOR" mode with CONSULT.
- Check that the "FUEL PRES SEN V" indication.

| Monitor Item    | Condition   | Values/Status  |
|-----------------|---|----------------|
| FUEL PRES SEN V | Engine speed: Idle  | 820 – 1,220 mV |
|                 | Engine speed: Revving engine from idle to 4,000 rpm quickly | 820 – 3,060 mV |

#### Ⓧ WITHOUT CONSULT

- Turn ignition switch OFF.
- Reconnect harness connector disconnected.
- Start the engine.
- Check FRP sensor signal voltage.

# P0191 FRP SENSOR

< DTC/CIRCUIT DIAGNOSIS >

[VK56VD FOR USA AND CANADA]

| +         |          | -         |          | Condition   | Value<br>(Approx.) |
|-----------|----------|-----------|----------|---|--------------------|
| ECM       |          |           |          |   |                    |
| Connector | Terminal | Connector | Terminal |   |                    |
| F110      | 31       | F110      | 40       | [Engine is running]<br>• Warm-up condition<br>• Idle speed                                    | 0.82 – 1.22 V      |
|           |          |           |          | [Engine is running]<br>• Warm-up condition<br>• Revving engine from idle to 4,000 rpm quickly | 0.82 – 3.06 V      |

Is the inspection result normal?

YES >> INSPECTION END.

NO >> Replace FRP sensor. Refer to [EM-197. "Exploded View"](#).

P0196 EOT SENSOR

DTC Logic

INFOID:000000007187552

DTC DETECTION LOGIC

NOTE:

If DTC P0196 is displayed with P0197 or P0198, first perform the trouble diagnosis for DTC P0197, P0198. Refer to [EC-1291, "DTC Logic"](#).

| DTC No. | Trouble diagnosis name<br>(Trouble diagnosis content)                 | DTC detecting condition |   | Possible cause  |
|---------|---|-------------------------|---|---|
| P0196   | EOT SENSOR<br>[Engine oil temperature (EOT) sensor range/performance] | A)                      | Rationally incorrect voltage from the sensor is sent to ECM, compared with the voltage signals from engine coolant temperature sensor and intake air temperature sensor.  | <ul style="list-style-type: none"> <li>• Harness or connectors (The EOT sensor circuit is open or shorted)</li> <li>• Engine oil temperature sensor</li> </ul>        |
|         |   | B)                      | The comparison result of signals transmitted to ECM from each temperature sensor (IAT sensor, ECT sensor, FTT sensor, and EOT sensor) shows that the signal voltage of the EOT sensor is higher/ lower than that of other temperature sensors when the engine is started with its cold state. | <ul style="list-style-type: none"> <li>• Harness or connectors (High or low resistance in the EOT sensor circuit)</li> <li>• Engine oil temperature sensor</li> </ul> |

DTC CONFIRMATION PROCEDURE

1.INSPECTION START

Is it necessary to erase permanent DTC?

- YES >> GO TO 6.
- NO >> GO TO 2.

2.PRECONDITIONING

If DTC CONFIRMATION PROCEDURE has been previously conducted, always perform the following procedure before conducting the next test.

1. Turn ignition switch OFF and wait at least 10 seconds.
2. Turn ignition switch ON.
3. Turn ignition switch OFF and wait at least 10 seconds.

**TESTING CONDITION:**

**Before performing the following procedure, confirm that battery voltage is 11 V or more at idle.**

>> GO TO 3.

3.PERFORM DTC CONFIRMATION PROCEDURE-I

1. Start engine and warm it up to normal operating temperature.
2. Turn ignition switch OFF and wait at least 10 seconds.
3. Turn ignition switch ON.
4. Turn ignition switch OFF and wait at least 10 seconds.
5. Start engine and let it idle for 5 minutes and 10 seconds.
6. Check 1st trip DTC.

Is 1st trip DTC detected?

- YES >> Proceed to [EC-1289, "Diagnosis Procedure"](#).
- NO >> GO TO 4.

4.PERFORM DTC CONFIRMATION PROCEDURE-II

Ⓜ WITH CONSULT

1. Select "DATA MONITOR" mode with CONSULT.
2. Check that "COOLAN TEMP/S" indicates above 70°C (158°F).  
If it is above 70°C (158°F), go to the following steps.

# P0196 EOT SENSOR

[VK56VD FOR USA AND CANADA]

## < DTC/CIRCUIT DIAGNOSIS >

If it is below 70°C (158°F), warm engine up until "COOLAN TEMP/S" indicates more than 70°C (158°F). Then perform the following steps.

3. Turn ignition switch OFF and soak the vehicle in a cool place.
4. Turn ignition switch ON.

**NOTE:**

**Do not turn ignition switch OFF until step 8.**

5. Select "DATA MONITOR" mode with CONSULT.
6. Check the following.

|  |                    |
|--|--------------------|
| COOLAN TEMP/S  | Below 40°C (104°F) |
| INT/A TEMP SE  | Below 40°C (104°F) |
| Difference between "COOLAN TEMP/S" and "INT/A TEMP SE" | Within 6°C (11°F)  |

If they are within the specified range, perform the following steps.

If they are out of the specified range, soak the vehicle to meet the above conditions. Then perform the following steps.

**NOTE:**

- **Do not turn ignition switch OFF.**
- **If it is supposed to need a long period of time, do not deplete the battery.**

7. Start engine and let it idle for 5 minutes.
8. Check 1st trip DTC.

 WITH GST

Follow the procedure "With CONSULT" above.

Is 1st trip DTC detected?

- YES >> [EC-1289, "Diagnosis Procedure"](#).  
NO >> GO TO 5.

## 5.PERFORM COMPONENT FUNCTION CHECK (FOR MALFUNCTION B)

Perform component function check. Refer to [EC-1289, "Component Function Check"](#).

**NOTE:**

Use the component function check to check the overall function of the EOT sensor circuit. During this check, a 1st trip DTC might not be confirmed.

Is the inspection result normal?

- YES >> INSPECTION END  
NO >> Proceed to [EC-1289, "Diagnosis Procedure"](#).

## 6.PRECONDITIONING

If DTC CONFIRMATION PROCEDURE has been previously conducted, always perform the following procedure before conducting the next test.

1. Turn ignition switch OFF and wait at least 10 seconds.
2. Turn ignition switch ON.
3. Turn ignition switch OFF and wait at least 10 seconds.

**TESTING CONDITION:**

- **Before performing the following procedure, do not add fuel.**
- **Before performing the following procedure, check that fuel level is between 1/4 and 4/4.**
- **Before performing the following procedure, confirm that battery voltage is 11 V or more at idle.**

>> GO TO 7.

## 7.PERFORM DTC CONFIRMATION PROCEDURE B

1. Start engine and let it idle for 60 minutes.
2. Move the vehicle to a cool place.

**NOTE:**

Cool the vehicle in an environment of ambient air temperature between -10°C (14°F) and 35°C (95°F).

3. Turn ignition switch OFF and soak the vehicle for 12 hours.

**CAUTION:**

**Never turn ignition switch ON during soaking.**

**NOTE:**

The vehicle must be cooled with the hood open.



# P0196 EOT SENSOR

[VK56VD FOR USA AND CANADA]

## < DTC/CIRCUIT DIAGNOSIS >

- Start engine and let it idle for 5 minutes or more.

**CAUTION:**

**Never turn ignition switch OFF during idling.**

- Check 1st trip DTC.

### Is 1st trip DTC detected?

- YES >> Proceed to [EC-1289, "Diagnosis Procedure"](#).  
NO >> INSPECTION END

## Component Function Check

INFOID:000000007202571

### 1.CHECK ENGINE OIL TEMPERATURE SENSOR

- Turn ignition switch OFF.
- Disconnect engine oil temperature sensor harness connector.
- Remove engine oil temperature sensor. Refer to [EM-226, "Exploded View"](#).
- Check resistance between engine oil temperature sensor terminals by heating with hot water as shown in the figure.

| Terminals | Condition             |          | Resistance (kΩ) |
|-----------|-----------------------|----------|-----------------|
| 1 and 2   | Temperature [°C (°F)] | 20 (68)  | 2.1 - 2.9       |
|           |                       | 50 (122) | 0.68 - 1.00     |
|           |                       | 90 (194) | 0.236 - 0.260   |

### Is the inspection result normal?

- YES >> GO TO 2.  
NO >> Replace engine oil temperature sensor. Refer to [EM-226, "Exploded View"](#).

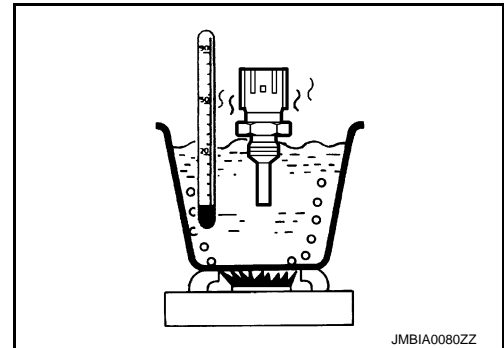

### 2.CHECK INTERMITTENT INCIDENT

Refer to [GI-44, "Intermittent Incident"](#).

### Is the inspection result normal?

- YES >> INSPECTION END  
NO >> Proceed to [EC-1289, "Diagnosis Procedure"](#).

## Diagnosis Procedure

INFOID:000000007187553

### 1.CHECK ENGINE OIL TEMPERATURE SENSOR

Check EOT sensor. Refer to [EC-1289, "Component Inspection \(Engine Oil Temperature Sensor\)"](#).

### Is the inspection result normal?

- YES >> GO TO 2.  
NO >> Replace engine oil temperature sensor. Refer to [EM-204, "2WD : Exploded View"](#) (2WD) or [EM-207, "AWD : Exploded View"](#) (AWD).

### 2.CHECK INTERMITTENT INCIDENT

Refer to [GI-44, "Intermittent Incident"](#).

>> INSPECTION END

## Component Inspection (Engine Oil Temperature Sensor)

INFOID:000000007187554

### 1.CHECK ENGINE OIL TEMPERATURE SENSOR

- Turn ignition switch OFF.
- Disconnect engine oil temperature sensor harness connector.
- Remove engine oil temperature sensor. Refer to [EM-226, "Exploded View"](#).

# P0196 EOT SENSOR

[VK56VD FOR USA AND CANADA]

## < DTC/CIRCUIT DIAGNOSIS >

4. Check resistance between engine oil temperature sensor terminals by heating with hot water as shown in the figure.

| Terminals | Condition             | Resistance (kΩ) |               |
|-----------|-----------------------|-----------------|---------------|
| 1 and 2   | Temperature [°C (°F)] | 20 (68)         | 2.1 - 2.9     |
|           |                       | 50 (122)        | 0.68 - 1.00   |
|           |                       | 90 (194)        | 0.236 - 0.260 |

Is the inspection result normal?

YES >> INSPECTION END

NO >> Replace engine oil temperature sensor. Refer to [EM-226, "Exploded View"](#).

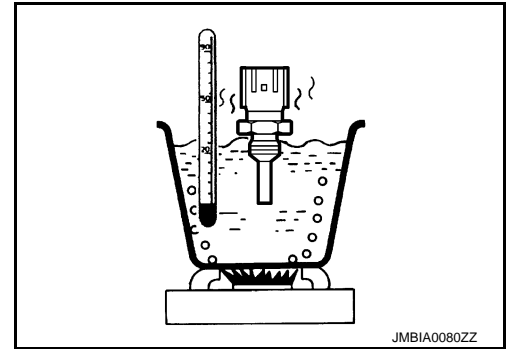

# P0197, P0198 EOT SENSOR

< DTC/CIRCUIT DIAGNOSIS >

[VK56VD FOR USA AND CANADA]

## P0197, P0198 EOT SENSOR

### DTC Logic

INFOID:000000007187555

### DTC DETECTION LOGIC

| DTC No. | Trouble diagnosis name<br>(Trouble diagnosis content)              | DTC Detecting Condition                                     | Possible Cause  |
|---------|--|---|---|
| P0197   | EOT SEN/CIRC<br>(Engine oil temperature sensor circuit low input)  | An excessively low voltage from the sensor is sent to ECM.  | <ul style="list-style-type: none"> <li>• Harness or connectors (The EOT sensor circuit is open or shorted.)</li> <li>• Engine oil temperature sensor</li> </ul> |
| P0198   | EOT SEN/CIRC<br>(Engine oil temperature sensor circuit high input) | An excessively high voltage from the sensor is sent to ECM. |   |

### DTC CONFIRMATION PROCEDURE

#### 1. PRECONDITIONING

If DTC Confirmation Procedure has been previously conducted, always perform the following procedure before conducting the next test.

1. Turn ignition switch OFF and wait at least 10 seconds.
2. Turn ignition switch ON.
3. Turn ignition switch OFF and wait at least 10 seconds.

>> GO TO 2.

#### 2. PERFORM DTC CONFIRMATION PROCEDURE

1. Start engine and wait at least 5 seconds.
2. Check 1st trip DTC.

Is 1st trip DTC detected?

- YES >> Proceed to [EC-1291, "Diagnosis Procedure"](#).  
 NO >> INSPECTION END

### Diagnosis Procedure

INFOID:000000007187556

#### 1. CHECK ENGINE OIL TEMPERATURE SENSOR POWER SUPPLY CIRCUIT

1. Disconnect engine oil temperature (EOT) sensor harness connector.
2. Turn ignition switch ON.
3. Check the voltage between EOT sensor harness connector and ground.

| EOT sensor |          | Ground | Voltage (V) |
|------------|----------|--------|-------------|
| Connector  | Terminal |        |             |
| F38        | 1        | Ground | Approx. 5   |

Is the inspection result normal?

- YES >> GO TO 2.  
 NO >> Repair open circuit, short to ground or short to power in harness or connectors.

#### 2. CHECK EOT SENSOR GROUND CIRCUIT FOR OPEN AND SHORT

1. Turn ignition switch OFF.
2. Disconnect ECM harness connector.
3. Check the continuity between EOT sensor harness connector and ECM harness connector.

| EOT sensor |          | ECM       |          | Continuity |
|------------|----------|-----------|----------|------------|
| Connector  | Terminal | Connector | Terminal |            |
| F38        | 2        | F110      | 40       | Existed    |

4. Also check harness for short to ground and short to power.

# P0197, P0198 EOT SENSOR

[VK56VD FOR USA AND CANADA]

< DTC/CIRCUIT DIAGNOSIS >

Is the inspection result normal?

YES >> GO TO 3.

NO >> Repair open circuit, short to ground or short to power in harness or connectors.

## 3.CHECK ENGINE OIL TEMPERATURE SENSOR

Refer to [EC-1292. "Component Inspection \(Engine Oil Temperature Sensor\)"](#).

Is the inspection result normal?

YES >> GO TO 4.

NO >> Replace engine oil temperature sensor. Refer to [EM-204. "2WD : Exploded View"](#) (2WD) or [EM-207. "AWD : Exploded View"](#) (AWD).

## 4.CHECK INTERMITTENT INCIDENT

Refer to [GI-44. "Intermittent Incident"](#).

>> INSPECTION END

## Component Inspection (Engine Oil Temperature Sensor)

INFOID:000000007187557

## 1.CHECK ENGINE OIL TEMPERATURE SENSOR

1. Turn ignition switch OFF.
2. Disconnect engine oil temperature sensor harness connector.
3. Remove engine oil temperature sensor. Refer to [EM-226. "Exploded View"](#).
4. Check resistance between engine oil temperature sensor terminals by heating with hot water as shown in the figure.

| Terminals | Condition             | Resistance (kΩ) |               |
|-----------|-----------------------|-----------------|---------------|
| 1 and 2   | Temperature [°C (°F)] | 20 (68)         | 2.1 - 2.9     |
|           |                       | 50 (122)        | 0.68 - 1.00   |
|           |                       | 90 (194)        | 0.236 - 0.260 |

Is the inspection result normal?

YES >> INSPECTION END

NO >> Replace engine oil temperature sensor. Refer to [EM-226. "Exploded View"](#).

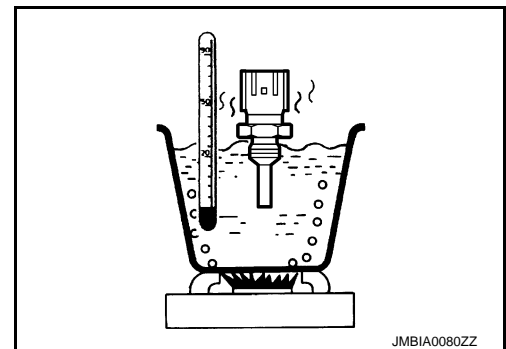

# P0201, P0202, P0203, P0204, P0205, P0206, P0207, P0208 INJECTOR

< DTC/CIRCUIT DIAGNOSIS >

[VK56VD FOR USA AND CANADA]

## P0201, P0202, P0203, P0204, P0205, P0206, P0207, P0208 INJECTOR

### DTC Logic

INFOID:000000007187558

### DTC DETECTION LOGIC

| DTC No. | Trouble diagnosis name      | DTC detecting condition                                | Possible cause   |
|---------|-----------------------------|--|--|
| P0201   | No.1 fuel injector circuit  | ECM detects No. 1 injector circuit is open or shorted. | <ul style="list-style-type: none"><li>• The fuel injector circuit is open or shorted</li><li>• Fuel injector</li><li>• ECM</li></ul> |
| P0202   | No. 2 fuel injector circuit | ECM detects No. 2 injector circuit is open or shorted. |  |
| P0203   | No. 3 fuel injector circuit | ECM detects No. 3 injector circuit is open or shorted. |  |
| P0204   | No. 4 fuel injector circuit | ECM detects No. 4 injector circuit is open or shorted. |  |
| P0205   | No. 5 fuel injector circuit | ECM detects No. 5 injector circuit is open or shorted. |  |
| P0206   | No. 6 fuel injector circuit | ECM detects No. 6 injector circuit is open or shorted. |  |
| P0207   | No. 7 fuel injector circuit | ECM detects No. 7 injector circuit is open or shorted. |  |
| P0208   | No. 8 fuel injector circuit | ECM detects No. 8 injector circuit is open or shorted. |  |

### DTC CONFIRMATION PROCEDURE

#### 1. PRECONDITIONING

1. Turn ignition switch OFF and wait at least 10 seconds.
2. Turn ignition switch ON.
3. Turn ignition switch OFF and wait at least 10 seconds.

#### TESTING CONDITION:

Before performing the following procedure, conform that battery voltage is 11 V or more at idle.

>> GO TO 2.

#### 2. PERFORM DTC CONFIRMATION PROCEDURE

1. Turn ignition switch OFF and wait at least 10 seconds.
2. Start the engine and let it idle at least 30 seconds.
3. Check 1st trip DTC.

Is 1st trip DTC detected?

YES >> Proceed to [EC-1293, "Diagnosis Procedure"](#).

NO >> INSPECTION END

### Diagnosis Procedure

INFOID:000000007187559

#### 1. PERFORM TROUBLE DIAGNOSIS FOR INJECTOR

Refer to [EC-1517, "Component Function Check"](#).

Is inspection result normal?

YES >> Check intermittent incident. Refer to [GI-44, "Intermittent Incident"](#).

NO >> Repair or replace error-detected parts.

# P0222, P0223, P2132, P2133 TP SENSOR

< DTC/CIRCUIT DIAGNOSIS >

[VK56VD FOR USA AND CANADA]

## P0222, P0223, P2132, P2133 TP SENSOR

### DTC Logic

INFOID:000000007187560

### DTC DETECTION LOGIC

#### NOTE:

If DTC P0222, P0223, P2132 or P2133 is displayed with DTC P0643, first perform the trouble diagnosis for DTC P0643. Refer to [EC-1389, "DTC Logic"](#).

| DTC No. | Trouble diagnosis name<br>(Trouble diagnosis content)                           | DTC detecting condition  | Possible cause   |
|---------|---|--|--|
| P0222   | TP SEN 1/CIRC-B1<br>[Throttle position sensor 1<br>(bank 1) circuit low input]  | An excessively low voltage from the TP sensor 1 is sent to ECM.  | <ul style="list-style-type: none"><li>• Harness or connectors (TP sensor 1 circuit is open or shorted.)</li><li>• Electric throttle control actuator (TP sensor 1)</li></ul> |
| P0223   | TP SEN 1/CIRC-B1<br>[Throttle position sensor 1<br>(bank 1) circuit high input] | An excessively high voltage from the TP sensor 1 is sent to ECM. |  |
| P2132   | TP SEN 1/CIRC-B2<br>[Throttle position sensor 1<br>(bank 2) circuit low input]  | An excessively low voltage from the TP sensor 1 is sent to ECM.  |  |
| P2133   | TP SEN 1/CIRC-B2<br>[Throttle position sensor 1<br>(bank 2) circuit high input] | An excessively high voltage from the TP sensor 1 is sent to ECM. |  |

### DTC CONFIRMATION PROCEDURE

#### 1. PRECONDITIONING

1. Turn ignition switch OFF and wait at least 10 seconds.
2. Turn ignition switch ON.
3. Turn ignition switch OFF and wait at least 10 seconds.

#### TESTING CONDITION:

Before performing the following procedure, confirm that battery voltage is 10 V or more at idle.

>> GO TO 2.

#### 2. PERFORM DTC CONFIRMATION PROCEDURE

1. Start engine and let it idle for 1 second.
2. Check DTC.

#### Is DTC detected?

YES >> Proceed to [EC-1294, "Diagnosis Procedure"](#).

NO >> INSPECTION END

### Diagnosis Procedure

INFOID:000000007187561

#### 1. CHECK THROTTLE POSITION SENSOR 1 POWER SUPPLY CIRCUIT-I

1. Disconnect electric throttle control actuator harness connector.
2. Turn ignition switch ON.
3. Check the voltage between electric throttle control actuator harness connector and ground.

| DTC          | Electric throttle control actuator |           |          | Ground | Voltage (V) |
|--------------|------------------------------------|-----------|----------|--------|-------------|
|              | Bank                               | Connector | Terminal |        |             |
| P0222, P0223 | 1                                  | F66       | 2        | Ground | Approx. 5   |
| P2132, P2133 | 2                                  | F64       | 2        |        |             |

#### Is the inspection result normal?

YES >> GO TO 2.

NO >> Repair open circuit, short to ground or short to power in harness or connectors.

# P0222, P0223, P2132, P2133 TP SENSOR

[VK56VD FOR USA AND CANADA]

< DTC/CIRCUIT DIAGNOSIS >

## 2. CHECK THROTTLE POSITION SENSOR 1 GROUND CIRCUIT FOR OPEN AND SHORT

1. Turn ignition switch OFF.
2. Disconnect ECM harness connector.
3. Check the continuity between electric throttle control actuator harness connector and ECM harness connector.

| DTC          | Electric throttle control actuator |           |          | ECM       |          | Continuity |
|--------------|------------------------------------|-----------|----------|-----------|----------|------------|
|              | Bank                               | Connector | Terminal | Connector | Terminal |            |
| P0222, P0223 | 1                                  | F66       | 4        | F111      | 97       | Existed    |
| P2132, P2133 | 2                                  | F64       | 4        |           | 69       |            |

4. Also check harness for short to ground and short to power.

Is the inspection result normal?

YES >> GO TO 3.

NO >> Repair open circuit, short to ground or short to power in harness or connectors.

## 3. CHECK THROTTLE POSITION SENSOR 1 INPUT SIGNAL CIRCUIT FOR OPEN AND SHORT

1. Check the continuity between electric throttle control actuator harness connector and ECM harness connector.

| DTC          | Electric throttle control actuator |           |          | ECM       |          | Continuity |
|--------------|------------------------------------|-----------|----------|-----------|----------|------------|
|              | Bank                               | Connector | Terminal | Connector | Terminal |            |
| P0222, P0223 | 1                                  | F66       | 1        | F111      | 91       | Existed    |
| P2132, P2133 | 2                                  | F64       | 1        |           | 71       |            |

2. Also check harness for short to ground and short to power.

Is the inspection result normal?

YES >> GO TO 4.

NO >> Repair open circuit, short to ground or short to power in harness or connectors.

## 4. CHECK THROTTLE POSITION SENSOR

Refer to [EC-1295, "Component Inspection \(Throttle Position Sensor\)"](#).

Is the inspection result normal?

YES >> GO TO 6.

NO >> GO TO 5.

## 5. REPLACE ELECTRIC THROTTLE CONTROL ACTUATOR

Replace malfunctioning electric throttle control actuator. Refer to [EM-191, "Removal and Installation"](#).

>> INSPECTION END

## 6. CHECK INTERMITTENT INCIDENT

Refer to [GI-44, "Intermittent Incident"](#).

>> INSPECTION END

## Component Inspection (Throttle Position Sensor)

INFOID:000000007187562

## 1. CHECK THROTTLE POSITION SENSOR

1. Turn ignition switch OFF.
2. Reconnect all harness connectors disconnected.
3. Perform [EC-1121, "Work Procedure"](#).
4. Turn ignition switch ON.
5. Set selector lever position to D.
6. Check the voltage between ECM harness connector terminals under the following conditions.

# P0222, P0223, P2132, P2133 TP SENSOR

< DTC/CIRCUIT DIAGNOSIS >

[VK56VD FOR USA AND CANADA]

| Connector | ECM                          |          | Condition                          | Voltage (V)    |
|-----------|------------------------------|----------|------------------------------------|----------------|
|           | +                            | -        |                                    |                |
|           | Terminal                     | Terminal |                                    |                |
| F111      | 91<br>[TP sensor 1 (bank 1)] | 97       | Accelerator pedal: Fully released  | More than 0.36 |
|           |                              |          | Accelerator pedal: Fully depressed | Less than 4.75 |
|           | 71<br>[TP sensor 1 (bank 2)] | 69       | Accelerator pedal: Fully released  | More than 0.36 |
|           |                              |          | Accelerator pedal: Fully depressed | Less than 4.75 |
|           | 79<br>[TP sensor 2 (bank 1)] | 97       | Accelerator pedal: Fully released  | Less than 4.75 |
|           |                              |          | Accelerator pedal: Fully depressed | More than 0.36 |
|           | 89<br>[TP sensor 2 (bank 2)] | 69       | Accelerator pedal: Fully released  | Less than 4.75 |
|           |                              |          | Accelerator pedal: Fully depressed | More than 0.36 |

Is the inspection result normal?

YES >> INSPECTION END

NO >> GO TO 2.

## 2. REPLACE ELECTRIC THROTTLE CONTROL ACTUATOR

Replace malfunctioning electric throttle control actuator. Refer to [EM-191. "Removal and Installation"](#).

>> INSPECTION END



# P0300, P0301, P0302, P0303, P0304, P0305, P0306, P0307, P0308 MISFIRE

< DTC/CIRCUIT DIAGNOSIS >

[VK56VD FOR USA AND CANADA]

## P0300, P0301, P0302, P0303, P0304, P0305, P0306, P0307, P0308 MISFIRE

### DTC Logic

INFOID:000000007187563

EC

### DTC DETECTION LOGIC

When a misfire occurs, engine speed will fluctuate. If the engine speed fluctuates enough to cause the crankshaft position (CKP) sensor signal to vary, ECM can determine that a misfire is occurring.

| Sensor                     | Input signal to ECM | ECM function                  |
|----------------------------|---------------------|-------------------------------|
| Crankshaft position sensor | Engine speed        | On board diagnosis of misfire |

The misfire detection logic consists of the following two conditions.

- One Trip Detection Logic (Three Way Catalyst Damage)**  
On the 1st trip that a misfire condition occurs that can damage the three way catalyst (TWC) due to overheating, the MIL will blink.  
When a misfire condition occurs, the ECM monitors the CKP sensor signal every 200 engine revolutions for a change.  
When the misfire condition decreases to a level that will not damage the TWC, the MIL will turn off.  
If another misfire condition occurs that can damage the TWC on a second trip, the MIL will blink.  
When the misfire condition decreases to a level that will not damage the TWC, the MIL will remain on.  
If another misfire condition occurs that can damage the TWC, the MIL will begin to blink again.
- Two Trip Detection Logic (Exhaust quality deterioration)**  
For misfire conditions that will not damage the TWC (but will affect vehicle emissions), the MIL will only light when the misfire is detected on a second trip. During this condition, the ECM monitors the CKP sensor signal every 1,000 engine revolutions.  
A misfire malfunction can be detected in any one cylinder or in multiple cylinders.

| DTC No. | Trouble diagnosis name<br>(Trouble diagnosis content)      | DTC detecting condition     | Possible cause   |
|---------|--|-----------------------------|--|
| P0300   | MULTI CYL MISFIRE<br>(Multiple cylinder misfires detected) | Multiple cylinders misfire. | <ul style="list-style-type: none"><li>• Improper spark plug</li><li>• Insufficient compression</li><li>• Incorrect fuel pressure</li><li>• The fuel injector circuit is open or shorted</li><li>• Fuel injector</li><li>• Intake air leakage</li><li>• The ignition signal circuit is open or shorted</li><li>• Lack of fuel</li><li>• Signal plate</li><li>• A/F sensor 1</li><li>• Incorrect PCV hose connection</li></ul> |
| P0301   | CYL 1 MISFIRE<br>(No.1 cylinder misfire detected)          | No. 1 cylinder misfires.    |  |
| P0302   | CYL 2 MISFIRE<br>(No. 2 cylinder misfire detected)         | No. 2 cylinder misfires.    |  |
| P0303   | CYL 3 MISFIRE<br>(No. 3 cylinder misfire detected)         | No. 3 cylinder misfires.    |  |
| P0304   | CYL 4 MISFIRE<br>(No. 4 cylinder misfire detected)         | No. 4 cylinder misfires.    |  |
| P0305   | CYL 5 MISFIRE<br>(No. 5 cylinder misfire detected)         | No. 5 cylinder misfires.    |  |
| P0306   | CYL 6 MISFIRE<br>(No. 6 cylinder misfire detected)         | No. 6 cylinder misfires.    |  |
| P0307   | CYL 7 MISFIRE<br>(No. 7 cylinder misfire detected)         | No. 7 cylinder misfires.    |  |
| P0308   | CYL 8 MISFIRE<br>(No. 8 cylinder misfire detected)         | No. 8 cylinder misfires.    |  |

### DTC CONFIRMATION PROCEDURE

#### 1. PRECONDITIONING

If DTC Confirmation Procedure has been previously conducted, always perform the following procedure before conducting the next test.

1. Turn ignition switch OFF and wait at least 10 seconds.
2. Turn ignition switch ON.
3. Turn ignition switch OFF and wait at least 10 seconds.

>> GO TO 2.

## 2. PERFORM DTC CONFIRMATION PROCEDURE-I

1. Start engine and warm it up to normal operating temperature.
2. Turn ignition switch OFF and wait at least 10 seconds.
3. Turn ignition switch ON.
4. Turn ignition switch OFF and wait at least 10 seconds.
5. Restart engine and let it idle for about 15 minutes.
6. Check 1st trip DTC.

Is 1st trip DTC detected?

YES >> Proceed to [EC-1298. "Diagnosis Procedure"](#).

NO >> GO TO 3.

## 3. PERFORM DTC CONFIRMATION PROCEDURE-II

1. Turn ignition switch OFF and wait at least 10 seconds.
2. Turn ignition switch ON.
3. Turn ignition switch OFF and wait at least 10 seconds.
4. Start engine and drive the vehicle under similar conditions to (1st trip) Freeze Frame Data for a certain time. Refer to the table below.

**Hold the accelerator pedal as steady as possible.**

Similar conditions to (1st trip) Freeze Frame Data mean that the following conditions should be satisfied at the same time.

**CAUTION:**

**Always drive vehicle in safe manner according to traffic conditions and obey all traffic laws when driving.**

|  |  |
|--|--|
| Engine speed                             | Engine speed in the freeze frame data $\pm$ 400 rpm  |
| Vehicle speed                            | Vehicle speed in the freeze frame data $\pm$ 10 km/h (6 MPH)   |
| Base fuel schedule                       | Base fuel schedule in the freeze frame data $\times$ (1 $\pm$ 0.1)   |
| Engine coolant temperature (T) condition | When the freeze frame data shows lower than 70°C (158°F), T should be lower than 70°C (158°F).                           |
|  | When the freeze frame data shows higher than or equal to 70°C (158°F), T should be higher than or equal to 70°C (158°F). |

Driving time varies according to the engine speed in the freeze frame data.

| Engine speed        | Time                      |
|---------------------|---------------------------|
| Around 1,000 rpm    | Approximately 10 minutes  |
| Around 2,000 rpm    | Approximately 5 minutes   |
| More than 3,000 rpm | Approximately 3.5 minutes |

5. Check 1st trip DTC.

Is 1st trip DTC detected?

YES >> Proceed to [EC-1298. "Diagnosis Procedure"](#).

NO >> INSPECTION END

## Diagnosis Procedure

INFOID:000000007187564

### 1. CHECK FOR INTAKE AIR LEAKAGE AND PCV HOSE

1. Start engine and run it at idle speed.
2. Listen for the sound of the intake air leakage.
3. Check PCV hose connection.

Is intake air leakage detected?

YES >> Discover air leakage location and repair.

NO >> GO TO 2.

# P0300, P0301, P0302, P0303, P0304, P0305, P0306, P0307, P0308 MISFIRE

< DTC/CIRCUIT DIAGNOSIS >

[VK56VD FOR USA AND CANADA]

## 2. CHECK FOR EXHAUST SYSTEM CLOGGING

Stop engine and visually check exhaust tube, three way catalyst and muffler for dents.

Is the inspection result normal?

- YES-1 >> With CONSULT: GO TO 3.
- YES-2 >> Without CONSULT: GO TO 4.
- NO >> Repair or replace malfunctioning part.

## 3. PERFORM POWER BALANCE TEST

Ⓜ WITH CONSULT

1. Start engine.
2. Perform "POWER BALANCE" in "ACTIVE TEST" mode with CONSULT.
3. Check that each circuit produces a momentary engine speed drop.

Is the inspection result normal?

- YES >> GO TO 9.
- NO >> GO TO 4.

## 4. CHECK FUNCTION OF FUEL INJECTOR-I

1. Start engine and let it idle.
2. Listen to each fuel injector operation.

**Clicking sound should be heard.**

Is the inspection result normal?

- YES >> GO TO 5.
- NO >> Perform trouble diagnosis for fuel injector, refer to [EC-1517, "Diagnosis Procedure"](#).

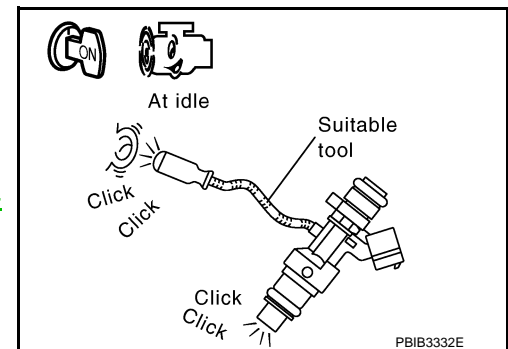

## 5. CHECK FUNCTION OF IGNITION COIL-I

### CAUTION:

Perform the following procedure in a place with no combustible objects and good ventilation.

1. Turn ignition switch OFF.
2. Remove fuel pump fuse No. in IPDM E/R to release fuel pressure.

### NOTE:

Do not use CONSULT to release fuel pressure, or fuel pressure applies again during the following procedure.

3. Start engine.
4. After engine stalls, crank it 2 or 3 times to release all fuel pressure.
5. Turn ignition switch OFF.
6. Remove all ignition coil harness connectors to avoid the electrical discharge from the ignition coils.
7. Remove ignition coil and spark plug of the cylinder to be checked. Refer to [EM-186, "Exploded View"](#).
8. Crank engine for 5 seconds or more to remove combustion gas in the cylinder.
9. Connect spark plug and harness connector to ignition coil.
10. Fix ignition coil using a rope etc. with gap of 13 - 17 mm (0.52 - 0.66 in) between the edge of the spark plug and grounded metal portion as shown in the figure.
11. Crank engine for approximately 3 seconds, and check whether spark is generated between the spark plug and the grounded metal portion.

**Spark should be generated.**

### CAUTION:

- Never place the spark plug and the ignition coil within 50 cm (19.7 in) each other. Be careful not to get an electrical shock while checking, because the electrical discharge voltage becomes 20 kV or more.

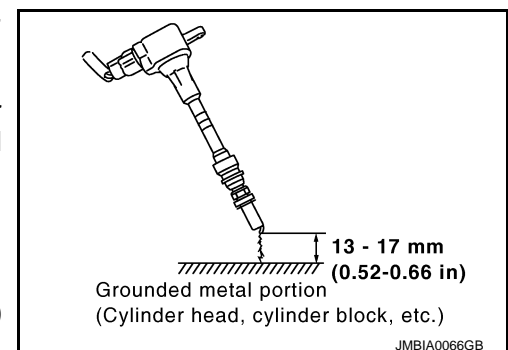

## P0300, P0301, P0302, P0303, P0304, P0305, P0306, P0307, P0308 MISFIRE

< DTC/CIRCUIT DIAGNOSIS >

[VK56VD FOR USA AND CANADA]

- It might damage the ignition coil if the gap of more than 17 mm (0.66 in) is made.

### NOTE:

When the gap is less than 13 mm (0.52 in), a spark might be generated even if the coil is malfunctioning.

Is the inspection result normal?

YES >> GO TO 9.

NO >> GO TO 6.

## 6. CHECK FUNCTION OF IGNITION COIL-II

1. Turn ignition switch OFF.
2. Disconnect spark plug and connect a non-malfunctioning spark plug.
3. Crank engine for approximately 3 seconds, and recheck whether spark is generated between the spark plug and the grounded metal portion.

**Spark should be generated.**

Is the inspection result normal?

YES >> GO TO 7.

NO >> Check ignition coil, power transistor and their circuits. Refer to [EC-1525. "Diagnosis Procedure"](#).

## 7. CHECK SPARK PLUG

Check the initial spark plug for fouling, etc.

Is the inspection result normal?

YES >> Replace spark plug(s) with standard type one(s). For spark plug type, refer to [MA-53. "SPARK PLUG \(VK56VD\) : Spark Plug"](#).

NO >> Repair or clean spark plug. Then GO TO 8.

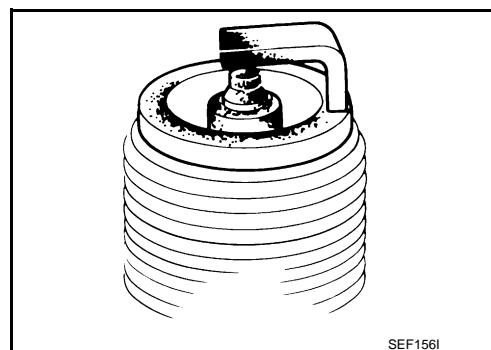

## 8. CHECK FUNCTION OF IGNITION COIL-III

1. Reconnect the initial spark plugs.
2. Crank engine for approximately 3 seconds, and recheck whether spark is generated between the spark plug and the grounded portion.

**Spark should be generated.**

Is the inspection result normal?

YES >> INSPECTION END

NO >> Replace spark plug(s) with standard type one(s). For spark plug type, refer to [MA-53. "SPARK PLUG \(VK56VD\) : Spark Plug"](#).

## 9. CHECK COMPRESSION PRESSURE

Check compression pressure. Refer to [EM-172. "Inspection"](#).

Is the inspection result normal?

YES >> GO TO 10.

NO >> Check pistons, piston rings, valves, valve seats and cylinder head gaskets.

## 10. CHECK FUEL PRESSURE

1. Install all removed parts.
2. Check fuel pressure. Refer to [EC-1127. "Work Procedure"](#).

Is the inspection result normal?

YES >> GO TO 12.

NO >> GO TO 11.

## 11. DETECT MALFUNCTIONING PART

# P0300, P0301, P0302, P0303, P0304, P0305, P0306, P0307, P0308 MISFIRE

< DTC/CIRCUIT DIAGNOSIS >

[VK56VD FOR USA AND CANADA]

Check fuel hoses and fuel tubes for clogging.

Is the inspection result normal?

- YES >> Replace "fuel filter and fuel pump assembly". Refer to [FL-6, "Removal and Installation"](#).  
NO >> Repair or replace malfunctioning part.

## 12.CHECK IDLE SPEED AND IGNITION TIMING

Check idle speed and ignition timing.

- Idle speed: For procedure, refer to [EC-1548, "Inspection"](#). For specification, refer to [EC-1556, "Idle Speed"](#)
- Ignition timing: For procedure, refer to [EC-1549, "Inspection"](#). For specification, refer to [EC-1556, "Ignition Timing"](#).

Is the inspection result normal?

- YES >> GO TO 13.  
NO >> Perform basic inspection. Refer to [EC-1113, "Work Procedure"](#).

## 13.CHECK A/F SENSOR 1 INPUT SIGNAL CIRCUIT

1. Turn ignition switch OFF.
2. Disconnect corresponding A/F sensor 1 harness connector.
3. Disconnect ECM harness connector.
4. Check the continuity between A/F sensor 1 harness connector and ECM harness connector.

| A/F sensor 1 |           |          | ECM       |          | Continuity |
|--------------|-----------|----------|-----------|----------|------------|
| Bank         | Connector | Terminal | Connector | Terminal |            |
| 1            | F23       | 3        | F111      | 88       | Existed    |
|              |           | 4        |           | 90       |            |
|              |           | 6        |           | 94       |            |
| 2            | F24       | 3        |           | 78       |            |
|              |           | 4        |           | 80       |            |
|              |           | 6        |           | 74       |            |

5. Check the continuity between A/F sensor 1 harness connector and ground, or ECM harness connector and ground.

| A/F sensor 1 |           |          | ECM       |          | Ground | Continuity |
|--------------|-----------|----------|-----------|----------|--------|------------|
| Bank         | Connector | Terminal | Connector | Terminal |        |            |
| 1            | F23       | 3        | F111      | 88       | Ground | Existed    |
|              |           | 4        |           | 90       |        |            |
|              |           | 6        |           | 94       |        |            |
| 2            | F24       | 3        |           | 78       |        |            |
|              |           | 4        |           | 80       |        |            |
|              |           | 6        |           | 74       |        |            |

6. Also check harness for short to power.

Is the inspection result normal?

- YES >> GO TO 14.  
NO >> Repair open circuit, short to ground or short to power in harness or connectors.

## 14.CHECK A/F SENSOR 1 HEATER

Refer to [EC-1174, "Component Inspection \(A/F Sensor 1 Heater\)"](#).

Is the inspection result normal?

- YES >> GO TO 15.  
NO >> Replace malfunctioning A/F sensor 1. Refer to [EM-223, "Exploded View"](#).

## 15.CHECK MASS AIR FLOW SENSOR

Ⓜ WITH CONSULT

## P0300, P0301, P0302, P0303, P0304, P0305, P0306, P0307, P0308 MISFIRE

< DTC/CIRCUIT DIAGNOSIS >

[VK56VD FOR USA AND CANADA]

Check mass air flow sensor signal in "DATA MONITOR" mode with CONSULT.

For specification, refer to [EC-1556, "Mass Air Flow Sensor"](#).

Ⓢ WITH GST

Check mass air flow sensor signal in Service \$01 with GST.

For specification, refer to [EC-1556, "Mass Air Flow Sensor"](#).

Is the measurement value within the specification?

YES >> GO TO 16.

NO >> Check connectors for rusted terminals or loose connections in the mass air flow sensor circuit or ground. Refer to [EC-1199, "Diagnosis Procedure"](#).

### 16.CHECK SYMPTOM MATRIX CHART

Check items on the rough idle symptom in [EC-1541, "Symptom Table"](#).

Is the inspection result normal?

YES >> GO TO 17.

NO >> Repair or replace malfunctioning part.

### 17.ERASE THE 1ST TRIP DTC

Some tests may cause a 1st trip DTC to be set.

Erase the 1st trip DTC from the ECM memory after performing the tests. Refer to [ⓈEC-1044, "CONSULT Function"](#) or [ⓧEC-1041, "On Board Diagnosis Function"](#).

>> GO TO 18.

### 18.CHECK INTERMITTENT INCIDENT

Refer to [GI-44, "Intermittent Incident"](#).

>> INSPECTION END

P0327, P0328, P0332, P0333 KS

DTC Logic

INFOID:000000007187565

DTC DETECTION LOGIC

| DTC No. | Trouble diagnosis name<br>(Trouble diagnosis content)           | DTC detected condition                                      | Possible cause   |
|---------|---|---|--|
| P0327   | KNOCK SEN/CIRC-B1<br>[Knock sensor (bank 1) circuit low input]  | An excessively low voltage from the sensor is sent to ECM.  | <ul style="list-style-type: none"> <li>• Harness or connectors (The knock sensor circuit is open or shorted.)</li> <li>• Knock sensor</li> </ul> |
| P0328   | KNOCK SEN/CIRC-B1<br>[Knock sensor (bank 1) circuit high input] | An excessively high voltage from the sensor is sent to ECM. |  |
| P0332   | KNOCK SEN/CIRC-B2<br>[Knock sensor (bank 2) circuit low input]  | An excessively low voltage from the sensor is sent to ECM.  |  |
| P0333   | KNOCK SEN/CIRC-B2<br>[Knock sensor (bank 2) circuit high input] | An excessively high voltage from the sensor is sent to ECM. |  |

DTC CONFIRMATION PROCEDURE

1. PRECONDITIONING

1. Turn ignition switch OFF and wait at least 10 seconds.
2. Turn ignition switch ON.
3. Turn ignition switch OFF and wait at least 10 seconds.

**TESTING CONDITION:**

Before performing the following procedure, confirm that battery voltage is 10 V or more at idle.

>> GO TO 2.

2. PERFORM DTC CONFIRMATION PROCEDURE

1. Start engine and run it for at least 5 seconds at idle speed.
2. Check 1st trip DTC.

Is 1st trip DTC detected?

- YES >> Proceed to [EC-1303, "Diagnosis Procedure"](#).  
 NO >> INSPECTION END

Diagnosis Procedure

INFOID:000000007187566

1. CHECK KNOCK SENSOR GROUND CIRCUIT FOR OPEN AND SHORT

1. Disconnect knock sensor harness connector and ECM harness connector.
2. Check the continuity between knock sensor harness connector and ECM harness connector.

| DTC          | Knock sensor |           |          | ECM       |          | Continuity |
|--------------|--------------|-----------|----------|-----------|----------|------------|
|              | Bank         | Connector | Terminal | Connector | Terminal |            |
| P0327, P0328 | 1            | F212      | 2        | F110      | 35       | Existed    |
| P0332, P0333 | 2            | F213      | 2        |           |          |            |

3. Also check harness for short to ground and short to power.

Is the inspection result normal?

- YES >> GO TO 3.  
 NO >> GO TO 2.

2. DETECT MALFUNCTIONING PART

Check the following.

## P0327, P0328, P0332, P0333 KS

< DTC/CIRCUIT DIAGNOSIS >

[VK56VD FOR USA AND CANADA]

- Harness for open or short between knock sensor and ECM
- Loose or poor connection for each connector and harness

>> Repair open circuit or short to power in harness or connectors.

### 3.CHECK KNOCK SENSOR INPUT SIGNAL CIRCUIT FOR OPEN AND SHORT

1. Check the continuity between knock sensor harness connector and ECM harness connector.

| DTC          | Knock sensor |           |          | ECM       |          | Continuity |
|--------------|--------------|-----------|----------|-----------|----------|------------|
|              | Bank         | Connector | Terminal | Connector | Terminal |            |
| P0327, P0328 | 1            | F212      | 1        | F110      | 29       | Existed    |
| P0332, P0333 | 2            | F213      | 1        |           | 33       |            |

2. Also check harness for short to ground and short to power.

Is the inspection result normal?

YES >> GO TO 5.

NO >> GO TO 4.

### 4.DETECT MALFUNCTIONING PART

Check the following.

- Harness for open or short between ECM and knock sensor
- Loose or poor connection for each connector and harness

>> Repair open circuit, short to ground or short to power in harness or connectors.

### 5.CHECK KNOCK SENSOR

Refer to [EC-1304, "Component Inspection \(Knock Sensor\)"](#).

Is the inspection result normal?

YES >> GO TO 6.

NO >> Replace malfunctioning knock sensor. Refer to [EM-274, "Exploded View"](#).

### 6.CHECK INTERMITTENT INCIDENT

Refer to [GI-44, "Intermittent Incident"](#).

>> INSPECTION END

## Component Inspection (Knock Sensor)

INFOID:000000007187567

### 1.CHECK KNOCK SENSOR

1. Turn ignition switch OFF.
2. Disconnect knock sensor harness connector.
3. Check resistance between knock sensor terminals as per the following.

**NOTE:**

**It is necessary to use an ohmmeter which can measure more than 10 MΩ.**

| Terminals | Resistance                            |
|-----------|---------------------------------------|
| 1 and 2   | Approx. 532 - 588 kΩ [at 20°C (68°F)] |

**CAUTION:**

**Never use any knock sensors that have been dropped or physically damaged. Use only new ones.**

Is the inspection result normal?

YES >> INSPECTION END

NO >> Replace malfunctioning knock sensor. Refer to [EM-274, "Exploded View"](#).



# P0335 CKP SENSOR

< DTC/CIRCUIT DIAGNOSIS >

[VK56VD FOR USA AND CANADA]

## P0335 CKP SENSOR

### DTC Logic

INFOID:000000007187568

### DTC DETECTION LOGIC

| DTC No. | Trouble diagnosis name<br>(Trouble diagnosis content)   | DTC detecting condition   | Possible cause  |
|---------|---|---|---|
| P0335   | CKP SEN/CIRCUIT<br>(Crankshaft position sensor circuit) | <ul style="list-style-type: none"> <li>The crankshaft position sensor signal is not detected by the ECM during the first few seconds of engine cranking.</li> <li>The proper pulse signal from the crankshaft position sensor is not sent to ECM while the engine is running.</li> <li>The crankshaft position sensor signal is not in the normal pattern during engine running.</li> </ul> | <ul style="list-style-type: none"> <li>Harness or connectors<br/>(Crankshaft position sensor circuit is open or shorted.)<br/>[Camshaft position sensor (bank 1) circuit is shorted.]<br/>(Accelerator pedal position sensor 2 circuit is shorted.)<br/>(Battery current sensor circuit is shorted.)<br/>(EVAP control system pressure sensor circuit is shorted.)<br/>(Refrigerant pressure sensor circuit is shorted.)</li> <li>Crankshaft position sensor</li> <li>Camshaft position sensor (bank 1)</li> <li>Accelerator pedal position sensor 2</li> <li>Battery current sensor</li> <li>EVAP control system pressure sensor</li> <li>Refrigerant pressure sensor</li> <li>Signal plate</li> </ul> |

### DTC CONFIRMATION PROCEDURE

#### 1. PRECONDITIONING

- Turn ignition switch OFF and wait at least 10 seconds.
- Turn ignition switch ON.
- Turn ignition switch OFF and wait at least 10 seconds.

#### TESTING CONDITION:

Before performing the following procedure, confirm that battery voltage is 10.5 V or more with ignition switch ON.

>> GO TO 2.

#### 2. PERFORM DTC CONFIRMATION PROCEDURE

- Start engine and let it idle for at least 5 seconds.  
If engine does not start, crank engine for at least 2 seconds.
- Check 1st trip DTC.

Is 1st trip DTC detected?

- YES >> Proceed to [EC-1305, "Diagnosis Procedure"](#).  
NO >> INSPECTION END

### Diagnosis Procedure

INFOID:000000007187569

#### 1. CHECK CRANKSHAFT POSITION SENSOR POWER SUPPLY CIRCUIT-I

- Disconnect crankshaft position (CKP) sensor harness connector.
- Turn ignition switch ON.
- Check the voltage between CKP sensor harness connector and ground.

| CKP sensor |          | Ground | Voltage (V) |
|------------|----------|--------|-------------|
| Connector  | Terminal |        |             |
| F2         | 1        | Ground | Approx. 5 V |

# P0335 CKP SENSOR

[VK56VD FOR USA AND CANADA]

< DTC/CIRCUIT DIAGNOSIS >

Is the inspection result normal?

YES >> GO TO 7.

NO >> GO TO 2.

## 2.CHECK CKP SENSOR POWER SUPPLY CIRCUIT-II

1. Turn ignition switch ON.
2. Disconnect ECM harness connector.
3. Check the continuity between CKP sensor harness connector and ECM harness connector.

| CKP sensor |          | ECM       |          | Continuity |
|------------|----------|-----------|----------|------------|
| Connector  | Terminal | Connector | Terminal |            |
| F2         | 1        | F111      | 76       | Existed    |

Is the inspection result normal?

YES >> GO TO 3.

NO >> Repair open circuit.

## 3.CHECK SENSOR POWER SUPPLY CIRCUIT

Check harness for short to power and short to ground, between the following terminals.

| ECM       |          | Sensor                              |           |          |
|-----------|----------|-------------------------------------|-----------|----------|
| Connector | Terminal | Name                                | Connector | Terminal |
| F111      | 76       | CKP sensor                          | F2        | 1        |
|           | 77       | Camshaft position sensor (bank 1)   | F84       | 1        |
| M160      | 133      | Battery current sensor              | E21       | 1        |
|           | 133      | EVAP control system pressure sensor | B73       | 3        |
|           | 133      | Refrigerant pressure sensor         | E77       | 3        |
|           | 137      | APP sensor 2 (Without ICC)          | M9        | 5        |
|           | 137      | APP sensor 2 (With ICC)             | M153      | 6        |

Is the inspection result normal?

YES >> GO TO 4.

NO >> Repair short to ground or short to power in harness or connectors.

## 4.CHECK COMPONENTS

Check the following.

- Camshaft position sensor (bank 1) (Refer to [EC-1312, "Component Inspection \(Camshaft Position Sensor\)"](#).)
- Battery current sensor (Refer to [EC-1438, "Component Inspection \(Battery Current Sensor\)"](#).)
- EVAP control system pressure sensor (Refer to [EC-1343, "Component Inspection \(EVAP Control System Pressure Sensor\)"](#).)
- Refrigerant pressure sensor (Refer to [EC-1539, "Diagnosis Procedure"](#).)

Is the inspection result normal?

YES >> GO TO 5.

NO >> Replace malfunctioning component.

## 5.CHECK APP SENSOR

Refer to [EC-1489, "Component Inspection \(Accelerator Pedal Position Sensor\)"](#).

Is the inspection result normal?

YES >> GO TO 11.

NO >> GO TO 6.

## 6.REPLACE ACCELERATOR PEDAL ASSEMBLY

Replace accelerator pedal assembly. Refer to following.

- Models with Distance Control Assist system: [ACC-4, "MODELS WITH DISTANCE CONTROL ASSIST SYSTEM : Removal and Installation"](#)

# P0335 CKP SENSOR

[VK56VD FOR USA AND CANADA]

< DTC/CIRCUIT DIAGNOSIS >

- Models without Distance Control Assist system: [ACC-3, "MODELS WITHOUT DISTANCE CONTROL ASSIST SYSTEM : Removal and Installation"](#)

>> INSPECTION END

## 7. CHECK CKP SENSOR GROUND CIRCUIT FOR OPEN AND SHORT

- Turn ignition switch OFF.
- Disconnect ECM harness connector.
- Check the continuity between CKP sensor harness connector and ECM harness connector.

| CKP sensor |          | ECM       |          | Continuity |
|------------|----------|-----------|----------|------------|
| Connector  | Terminal | Connector | Terminal |            |
| F2         | 2        | F111      | 98       | Existed    |

- Also check harness for short to ground and short to power.

Is the inspection result normal?

YES >> GO TO 8.

NO >> Repair open circuit, short to ground or short to power in harness or connectors.

## 8. CHECK CKP SENSOR INPUT SIGNAL CIRCUIT FOR OPEN AND SHORT

- Check the continuity between CKP sensor harness connector and ECM harness connector.

| CKP sensor |          | ECM       |          | Continuity |
|------------|----------|-----------|----------|------------|
| Connector  | Terminal | Connector | Terminal |            |
| F2         | 3        | F111      | 86       | Existed    |

- Also check harness for short to ground and short to power.

Is the inspection result normal?

YES >> GO TO 9.

NO >> Repair open circuit, short to ground or short to power in harness or connectors.

## 9. CHECK CRANKSHAFT POSITION SENSOR

Refer to [EC-1307, "Component Inspection \(Crankshaft Position Sensor\)"](#).

Is the inspection result normal?

YES >> GO TO 10.

NO >> Replace crankshaft position sensor. Refer to [EM-226, "Exploded View"](#) (2WD) or [EM-204, "2WD : Exploded View"](#) (AWD).

## 10. CHECK GEAR TOOTH

Visually check for chipping signal plate gear tooth.

Is the inspection result normal?

YES >> GO TO 11.

NO >> Replace the signal plate. Refer to [EM-274, "Exploded View"](#)

## 11. CHECK INTERMITTENT INCIDENT

Refer to [GI-44, "Intermittent Incident"](#).

>> INSPECTION END

## Component Inspection (Crankshaft Position Sensor)

INFOID:000000007187570

### 1. CHECK CRANKSHAFT POSITION SENSOR-I

- Turn ignition switch OFF.
- Loosen the fixing bolt of the sensor.
- Disconnect crankshaft position sensor harness connector.
- Remove the sensor. Refer to [EM-226, "Exploded View"](#).

## P0335 CKP SENSOR

[VK56VD FOR USA AND CANADA]

< DTC/CIRCUIT DIAGNOSIS >

5. Visually check the sensor for chipping.

Is the inspection result normal?

YES >> GO TO 2.

NO >> Replace crankshaft position sensor. Refer to [EM-226](#), "[Exploded View](#)".

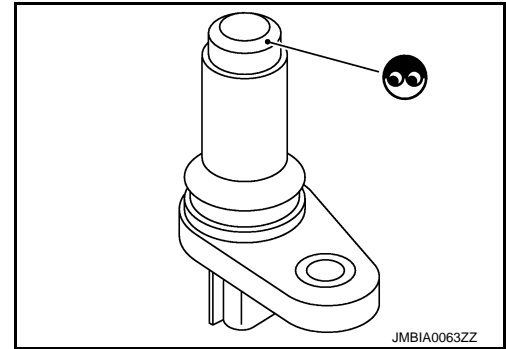

## 2. CHECK CRANKSHAFT POSITION SENSOR-II

Check resistance between crankshaft position sensor terminals as per the following.

| Terminals (Polarity) | Resistance                                     |
|----------------------|--|
| 1 (+) - 2 (-)        | Except 0 or $\infty$ $\Omega$ [at 25°C (77°F)] |
| 1 (+) - 3 (-)        |  |
| 2 (+) - 3 (-)        |  |

Is the inspection result normal?

YES >> INSPECTION END

NO >> Replace crankshaft position sensor. Refer to [EM-226](#), "[Exploded View](#)".

# P0340, P0345 CMP SENSOR

< DTC/CIRCUIT DIAGNOSIS >

[VK56VD FOR USA AND CANADA]

## P0340, P0345 CMP SENSOR

### DTC Logic

INFOID:000000007187571

### DTC DETECTION LOGIC

**NOTE:**

If DTC P0345 is displayed with DTC P0643, first perform the trouble diagnosis for DTC P0643. Refer to [EC-1389, "DTC Logic"](#).

| DTC No. | Trouble diagnosis name<br>(Trouble diagnosis content)             | DTC detecting condition  | Possible cause  |
|---------|---|--|---|
| P0340   | CMP SEN/CIRC-B1<br>[Camshaft position sensor<br>(bank 1) circuit] | <ul style="list-style-type: none"> <li>The cylinder No. signal is not sent to ECM for the first few seconds during engine cranking.</li> <li>The cylinder No. signal is not sent to ECM during engine running.</li> <li>The cylinder No. signal is not in the normal pattern during engine running.</li> </ul> | <ul style="list-style-type: none"> <li>Harness or connectors<br/>[Camshaft position sensor (bank 1) circuit is shorted.]<br/>(Crankshaft position sensor circuit is open or shorted.)<br/>(Accelerator pedal position sensor 2 circuit is shorted.)<br/>(Battery current sensor circuit is shorted.)<br/>(EVAP control system pressure sensor circuit is shorted.)<br/>(Refrigerant pressure sensor circuit is short-ed.)</li> <li>Camshaft position sensor (bank 1)</li> <li>Crankshaft position sensor</li> <li>Accelerator pedal position sensor 2</li> <li>Battery current sensor</li> <li>EVAP control system pressure sensor</li> <li>Refrigerant pressure sensor</li> <li>Camshaft (INT)</li> <li>Starter motor</li> <li>Starting system circuit</li> <li>Dead (Weak) battery</li> </ul> |
| P0345   | Camshaft position sensor<br>(bank 2) circuit<br>(CMP SEN/CIRC-B2) |  | <ul style="list-style-type: none"> <li>Harness or connectors<br/>[Camshaft position sensor (bank 2) circuit is open or shorted.]</li> <li>Camshaft position sensor (bank 2)</li> <li>Camshaft (INT)</li> <li>Starter motor</li> <li>Starting system circuit</li> <li>Dead (Weak) battery</li> </ul>   |

### DTC CONFIRMATION PROCEDURE

#### 1. PRECONDITIONING

- Turn ignition switch OFF and wait at least 10 seconds.
- Turn ignition switch ON.
- Turn ignition switch OFF and wait at least 10 seconds.

**TESTING CONDITION:**

Before performing the following procedure, confirm that battery voltage is 10.5 V or more with ignition switch ON.

>> GO TO 2.

#### 2. PERFORM DTC CONFIRMATION PROCEDURE-I

- Start engine and let it idle for at least 5 seconds.  
If engine does not start, crank engine for at least 2 seconds.
- Check 1st trip DTC.

Is 1st trip DTC detected?

- YES >> Proceed to [EC-1310, "Diagnosis Procedure"](#).  
NO >> GO TO 3.

# P0340, P0345 CMP SENSOR

[VK56VD FOR USA AND CANADA]

< DTC/CIRCUIT DIAGNOSIS >

## 3.PERFORM DTC CONFIRMATION PROCEDURE-I

1. Maintain engine speed at more than 800 rpm for at least 5 seconds.
2. Check 1st trip DTC.

Is 1st trip DTC detected?

- YES >> Proceed to [EC-1310, "Diagnosis Procedure"](#).  
NO >> INSPECTION END

## Diagnosis Procedure

INFOID:000000007187572

### 1.CHECK STARTING SYSTEM

Turn ignition switch to START position.

Does the engine turn over? Does the starter motor operate?

- YES >> GO TO 2.  
NO >> Check starting system. Refer to [STR-9, "Work Flow"](#).

### 2.CHECK CAMSHAFT POSITION SENSOR POWER SUPPLY CIRCUIT-I

1. Disconnect camshaft position (CMP) sensor harness connector.
2. Turn ignition switch ON.
3. Check the voltage between CMP sensor harness connector and ground.

| DTC   | CMP sensor |           |          | Ground | Voltage (V) |
|-------|------------|-----------|----------|--------|-------------|
|       | Bank       | Connector | Terminal |        |             |
| P0340 | 1          | F84       | 1        | Ground | Approx. 5   |
| P0345 | 2          | F83       | 1        |        |             |

Is the inspection result normal?

- YES >> GO TO 8.  
NO-1 >> P0340: GO TO 3.  
NO-2 >> P0345: Repair open circuit, short to ground or short to power in harness or connectors.

### 3.CHECK CMP SENSOR POWER SUPPLY CIRCUIT-II

1. Turn ignition switch OFF.
2. Disconnect ECM harness connector.
3. Check the continuity between CMP sensor harness connector and ECM harness connector.

| CMP sensor |           |          | ECM       |          | Continuity |
|------------|-----------|----------|-----------|----------|------------|
| Bank       | Connector | Terminal | Connector | Terminal |            |
| 1          | F84       | 1        | F111      | 77       | Existed    |

Is the inspection result normal?

- YES >> GO TO 4.  
NO >> Repair open circuit.

### 4.CHECK SENSOR POWER SUPPLY CIRCUIT

Check harness for short to power and short to ground, between the following terminals.

| ECM       |          | Sensor                            |           |          |
|-----------|----------|-----------------------------------|-----------|----------|
| Connector | Terminal | Name                              | Connector | Terminal |
| F111      | 76       | CKP sensor                        | F2        | 1        |
|           | 77       | Camshaft position sensor (bank 1) | F84       | 1        |

# P0340, P0345 CMP SENSOR

< DTC/CIRCUIT DIAGNOSIS >

[VK56VD FOR USA AND CANADA]

| ECM       |          | Sensor                              |           |          |
|-----------|----------|-------------------------------------|-----------|----------|
| Connector | Terminal | Name                                | Connector | Terminal |
| M160      | 133      | Battery current sensor              | E21       | 1        |
|           | 133      | EVAP control system pressure sensor | B73       | 3        |
|           | 133      | Refrigerant pressure sensor         | E77       | 3        |
|           | 137      | APP sensor 2 (Without ICC)          | M9        | 5        |
|           | 137      | APP sensor 2 (With ICC)             | M153      | 6        |

Is the inspection result normal?

YES >> GO TO 5.

NO >> Repair short to ground or short to power in harness or connectors.

## 5. CHECK COMPONENTS

Check the following.

- CKP sensor (Refer to [EC-1307. "Component Inspection \(Crankshaft Position Sensor\)"](#).)
- Camshaft position sensor (bank 1) (Refer to [EC-1312. "Component Inspection \(Camshaft Position Sensor\)"](#).)
- Battery current sensor (Refer to [EC-1438. "Component Inspection \(Battery Current Sensor\)"](#).)
- EVAP control system pressure sensor (Refer to [EC-1343. "Component Inspection \(EVAP Control System Pressure Sensor\)"](#).)
- Refrigerant pressure sensor (Refer to [EC-1539. "Diagnosis Procedure"](#).)

Is the inspection result normal?

YES >> GO TO 6.

NO >> Replace malfunctioning component.

## 6. CHECK APP SENSOR

Refer to [EC-1489. "Component Inspection \(Accelerator Pedal Position Sensor\)"](#).

Is the inspection result normal?

YES >> GO TO 12.

NO >> GO TO 7.

## 7. REPLACE ACCELERATOR PEDAL ASSEMBLY

Replace accelerator pedal assembly. Refer to following.

- Models without Distance Control Assist system: [ACC-3. "MODELS WITHOUT DISTANCE CONTROL ASSIST SYSTEM : Removal and Installation"](#)
- Models with Distance Control Assist system: [ACC-4. "MODELS WITH DISTANCE CONTROL ASSIST SYSTEM : Removal and Installation"](#)

>> INSPECTION END

## 8. CHECK CMP SENSOR GROUND CIRCUIT FOR OPEN AND SHORT

1. Turn ignition switch OFF.
2. Disconnect ECM harness connector.
3. Check the continuity between CMP sensor harness connector and ECM harness connector.

| DTC   | CMP sensor |           |          | ECM       |          | Continuity |
|-------|------------|-----------|----------|-----------|----------|------------|
|       | Bank       | Connector | Terminal | Connector | Terminal |            |
| P0340 | 1          | F84       | 2        | F111      | 68       | Existed    |
| P0345 | 2          | F83       | 2        |           | 99       |            |

4. Also check harness for short to ground and short to power.

Is the inspection result normal?

YES >> GO TO 9.

NO >> Repair open circuit, short to ground or short to power in harness or connectors.

## 9. CHECK CMP SENSOR INPUT SIGNAL CIRCUIT FOR OPEN AND SHORT

## P0340, P0345 CMP SENSOR

< DTC/CIRCUIT DIAGNOSIS >

[VK56VD FOR USA AND CANADA]

1. Check the continuity between CMP sensor harness connector and ECM harness connector.

| DTC   | CMP sensor |           |          | ECM       |          | Continuity |
|-------|------------|-----------|----------|-----------|----------|------------|
|       | Bank       | Connector | Terminal | Connector | Terminal |            |
| P0340 | 1          | F84       | 3        | F111      | 95       | Existed    |
| P0345 | 2          | F83       | 3        |           | 73       |            |

2. Also check harness for short to ground and short to power.

Is the inspection result normal?

YES >> GO TO 10.

NO >> Repair open circuit, short to ground or short to power in harness or connectors.

### 10. CHECK CAMSHAFT POSITION SENSOR

Refer to [EC-1312, "Component Inspection \(Camshaft Position Sensor\)"](#).

Is the inspection result normal?

YES >> GO TO 11.

NO >> Replace malfunctioning camshaft position sensor.

### 11. CHECK CAMSHAFT SPROCKET (SIGNAL PLATE)

Check the following.

- Accumulation of debris to the signal plate of camshaft sprocket (INT)
- Chipping signal plate of camshaft sprocket (INT)

Is the inspection result normal?

YES >> GO TO 12.

NO >> Remove debris and clean the signal plate of camshaft sprocket (INT).

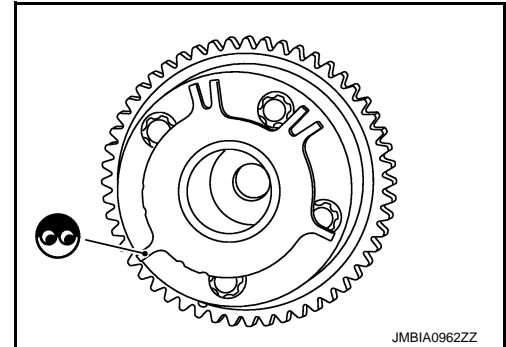

### 12. CHECK INTERMITTENT INCIDENT

Refer to [GI-44, "Intermittent Incident"](#).

>> INSPECTION END

## Component Inspection (Camshaft Position Sensor)

INFOID:000000007187573

### 1. CHECK CAMSHAFT POSITION SENSOR-I

1. Turn ignition switch OFF.
2. Loosen the fixing bolt of the sensor.
3. Disconnect camshaft position sensor harness connector.
4. Remove the sensor. Refer to [EM-231, "Exploded View"](#).
5. Visually check the sensor for chipping.

Is the inspection result normal?

YES >> GO TO 2.

NO >> Replace malfunctioning camshaft position sensor.

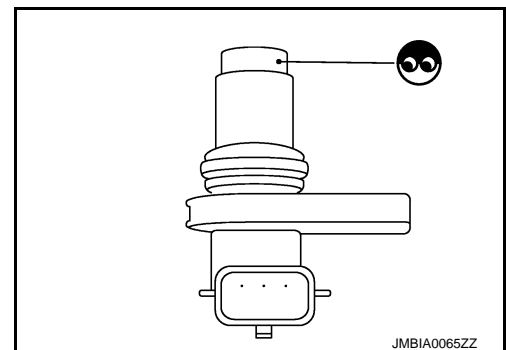

### 2. CHECK CAMSHAFT POSITION SENSOR-II

Check resistance camshaft position sensor terminals as per the following.



# P0340, P0345 CMP SENSOR

< DTC/CIRCUIT DIAGNOSIS >

[VK56VD FOR USA AND CANADA]

| Terminals (Polarity) | Resistance                                     |
|----------------------|--|
| 1 (+) - 2 (-)        | Except 0 or $\infty$ $\Omega$ [at 25°C (77°F)] |
| 1 (+) - 3 (-)        |  |
| 2 (+) - 3 (-)        |  |

A

EC

Is the inspection result normal?

YES >> INSPECTION END

NO >> Replace malfunctioning camshaft position sensor.

C

D

E

F

G

H

I

J

K

L

M

N

O

P

# P0420, P0430 THREE WAY CATALYST FUNCTION

< DTC/CIRCUIT DIAGNOSIS >

[VK56VD FOR USA AND CANADA]

## P0420, P0430 THREE WAY CATALYST FUNCTION

### DTC Logic

INFOID:000000007187574

#### DTC DETECTION LOGIC

The ECM monitors the switching frequency ratio of air fuel ratio (A/F) sensor 1 and heated oxygen sensor 2.

A three way catalyst (manifold) with high oxygen storage capacity will indicate a low switching frequency of heated oxygen sensor 2. As oxygen storage capacity decreases, the heated oxygen sensor 2 switching frequency will increase.

When the frequency ratio of A/F sensor 1 and heated oxygen sensor 2 approaches a specified limit value, the three way catalyst (manifold) malfunction is diagnosed.

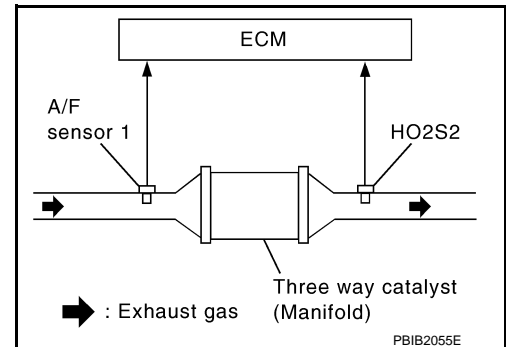

| DTC No. | Trouble diagnosis name (Trouble diagnosis content)                       | DTC detecting condition   | Possible cause  |
|---------|--|---|---|
| P0420   | TW CATALYST SYS-B1 [Catalyst system efficiency below threshold (bank 1)] | <ul style="list-style-type: none"> <li>Three way catalyst (manifold) does not operate properly.</li> <li>Three way catalyst (manifold) does not have enough oxygen storage capacity.</li> </ul> | <ul style="list-style-type: none"> <li>Three way catalyst (manifold)</li> <li>Exhaust tube</li> <li>Intake air leakage</li> <li>Fuel injector</li> <li>Fuel injector leakage</li> <li>Spark plug</li> <li>Improper ignition timing</li> </ul> |
| P0430   | TW CATALYST SYS-B2 [Catalyst system efficiency below threshold (bank 2)] |   |   |

### DTC CONFIRMATION PROCEDURE

#### 1. INSPECTION START

If DTC Confirmation Procedure has been previously conducted, always perform the following procedure before conducting the next test.

1. Turn ignition switch OFF and wait at least 10 seconds.
2. Turn ignition switch ON.
3. Turn ignition switch OFF and wait at least 10 seconds.

Will CONSULT be used?

- YES >> GO TO 2.  
NO >> GO TO 6.

#### 2. PERFORM DTC CONFIRMATION PROCEDURE-I

Ⓟ WITH CONSULT

#### TESTING CONDITION:

**Do not maintain engine speed for more than the specified minutes below.**

1. Start engine and warm it up to the normal operating temperature.
2. Turn ignition switch OFF and wait at least 10 seconds.
3. Turn ignition switch ON.
4. Turn ignition switch OFF and wait at least 10 seconds.
5. Start engine and keep the engine speed between 3,500 and 4,000 rpm for at least 1 minute under no load.
6. Let engine idle for 1 minute.
7. Select "DATA MONITOR" mode with CONSULT.
8. Check that "COOLAN TEMP/S" indicates more than 70°C (158°F).  
If not, warm up engine and go to next step when "COOLAN TEMP/S" indication reaches to 70°C (158°F).
9. Open engine hood.
10. Select "DTC & SRT CONFIRMATION" then "SRT WORK SUPPORT" mode with CONSULT.
11. Rev engine between 2,000 and 3,000 rpm and hold it for 3 consecutive minutes then release the accelerator pedal completely.
12. Check the indication of "CATALYST".

Which is displayed on CONSULT screen?

# P0420, P0430 THREE WAY CATALYST FUNCTION

[VK56VD FOR USA AND CANADA]

< DTC/CIRCUIT DIAGNOSIS >

- CMPLT >> GO TO 5.
- INCMP >> GO TO 3.

## 3. PERFORM DTC CONFIRMATION PROCEDURE-II

1. Wait 5 seconds at idle.
2. Rev engine between 2,000 and 3,000 rpm and maintain it until "INCMP" of "CATALYST" changes to "CMPLT" (It will take approximately 5 minutes).

Does the indication change to "CMPLT"?

- YES >> GO TO 5.
- NO >> GO TO 4.

## 4. PERFORM DTC CONFIRMATION PROCEDURE AGAIN

1. Stop engine and cool it down to less than 70°C (158°F).
2. Perform DTC CONFIRMATION PROCEDURE again.

>> GO TO 2.

## 5. PERFORM DTC CONFIRMATION PROCEDURE-III

Check 1st trip DTC.

Is 1st trip DTC detected?

- YES >> Proceed to [EC-1316. "Diagnosis Procedure"](#).
- NO >> INSPECTION END

## 6. PERFORM COMPONENT FUNCTION CHECK

 WITH GST

Perform component function check. Refer to [EC-1315. "Component Function Check"](#).

### NOTE:

Use component function check to check the overall function of the three way catalyst (manifold). During this check, a 1st trip DTC might not be confirmed.

Is the inspection result normal?

- YES >> INSPECTION END
- NO >> Proceed to [EC-1316. "Diagnosis Procedure"](#)

## Component Function Check

INFOID:000000007187575

## 1. PERFORM COMPONENT FUNCTION CHECK

 With GST

1. Start engine and warm it up to the normal operating temperature.
2. Turn ignition switch OFF and wait at least 10 seconds.
3. Start engine and keep the engine speed between 3,500 and 4,000 rpm for at least 1 minute under no load.
4. Let engine idle for 1 minute.
5. Open engine hood.
6. Check the voltage between ECM harness connector terminals under the following conditions.

| DTC   | ECM       |                           |          | Condition  | Voltage  |
|-------|-----------|---------------------------|----------|--|--|
|       | Connector | +                         | -        |  |  |
|       |           | Terminal                  | Terminal |  |  |
| P0420 | F110      | 96<br>[HO2S2<br>(bank 1)] | 100      | Keeping engine speed at 2,500 rpm constant under no load | The voltage fluctuation cycle takes more than 5 seconds.<br>• 1 cycle: 0.6 - 1.0 → 0 - 0.3 → 0.6 - 1.0 |
| P0430 |           | 87<br>[HO2S2<br>(bank 2)] |          |  |  |

Is the inspection result normal?

- YES >> INSPECTION END
- NO >> Proceed to [EC-1316. "Diagnosis Procedure"](#).

# P0420, P0430 THREE WAY CATALYST FUNCTION

[VK56VD FOR USA AND CANADA]

< DTC/CIRCUIT DIAGNOSIS >

INFOID:000000007187576

## Diagnosis Procedure

### 1. CHECK EXHAUST SYSTEM

Visually check exhaust tubes and muffler for dents.

Is the inspection result normal?

YES >> GO TO 2.

NO >> Repair or replace malfunctioning part.

### 2. CHECK EXHAUST GAS LEAKAGE

1. Start engine and run it at idle.

2. Listen for an exhaust gas leakage before the three way catalyst (manifold).

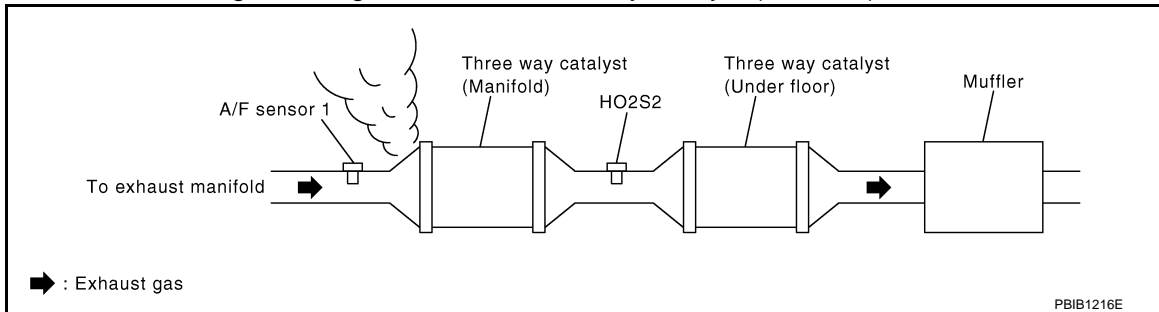

Is exhaust gas leakage detected?

YES >> Repair or replace malfunctioning part.

NO >> GO TO 3.

### 3. CHECK INTAKE AIR LEAKAGE

Listen for an intake air leakage after the mass air flow sensor.

Is intake air leakage detected?

YES >> Repair or replace malfunctioning part.

NO >> GO TO 4.

### 4. CHECK IDLE SPEED AND IGNITION TIMING

Check idle speed and ignition timing.

For procedure, refer to [EC-1113, "Work Procedure"](#).

For specification, refer to [EC-1556, "Idle Speed"](#) and [EC-1556, "Ignition Timing"](#).

Is the inspection result normal?

YES >> GO TO 5.

NO >> Follow the [EC-1113, "Work Procedure"](#).

### 5. CHECK FUEL INJECTORS

Refer to [EC-1517, "Component Function Check"](#).

Is the inspection result normal?

YES >> GO TO 6.

NO >> Perform [EC-1517, "Diagnosis Procedure"](#).

### 6. CHECK FUNCTION OF IGNITION COIL-I

#### CAUTION:

**Perform the following procedure in a place with no combustible objects and good ventilation.**

1. Turn ignition switch OFF.
2. Remove fuel pump fuse in IPDM E/R to release fuel pressure.

#### NOTE:

- For the fuse number, refer to [EC-1100, "Wiring Diagram"](#).
  - For the fuse arrangement, refer to [PG-41, "Connector and Terminal Arrangement"](#).
  - Do not use CONSULT to release fuel pressure, or fuel pressure applies again during the following procedure.
3. Start engine.
  4. After engine stalls, crank it 2 or 3 times to release all fuel pressure.
  5. Turn ignition switch OFF.

# P0420, P0430 THREE WAY CATALYST FUNCTION

[VK56VD FOR USA AND CANADA]

## < DTC/CIRCUIT DIAGNOSIS >

6. Remove all ignition coil harness connectors to avoid the electrical discharge from the ignition coils.
7. Remove ignition coil and spark plug of the cylinder to be checked. Refer to [EM-186, "Exploded View"](#).
8. Crank engine for 5 seconds or more to remove combustion gas in the cylinder.
9. Connect spark plug and harness connector to ignition coil.
10. Fix ignition coil using a rope etc. with gap of 13 - 17 mm (0.52 - 0.66 in) between the edge of the spark plug and grounded metal portion as shown in the figure.
11. Crank engine for approximately 3 seconds, and check whether spark is generated between the spark plug and the grounded metal portion.

**Spark should be generated.**

### CAUTION:

- Never place the spark plug and the ignition coil within 50 cm (19.7 in) each other. Be careful not to get an electrical shock while checking, because the electrical discharge voltage becomes 20 kV or more.
- It might damage the ignition coil if the gap of more than 17 mm (0.66 in) is made.

### NOTE:

When the gap is less than 13 mm (0.52 in), a spark might be generated even if the coil is malfunctioning.

Is the inspection result normal?

- YES >> GO TO 10.  
NO >> GO TO 7.

## 7.CHECK FUNCTION OF IGNITION COIL-II

1. Turn ignition switch OFF.
2. Disconnect spark plug and connect a non-malfunctioning spark plug.
3. Crank engine for approximately 3 seconds, and recheck whether spark is generated between the spark plug and the grounded metal portion.

**Spark should be generated.**

Is the inspection result normal?

- YES >> GO TO 8.  
NO >> Check ignition coil, power transistor and their circuits. Refer to [EC-1525, "Diagnosis Procedure"](#).

## 8.CHECK SPARK PLUG

Check the initial spark plug for fouling, etc.

Is the inspection result normal?

- YES >> Replace spark plug(s) with standard type one(s). For spark plug type, refer to [MA-53, "SPARK PLUG \(VK56VD\) : Spark Plug"](#).
- NO >> Repair or clean spark plug. Then GO TO 9.

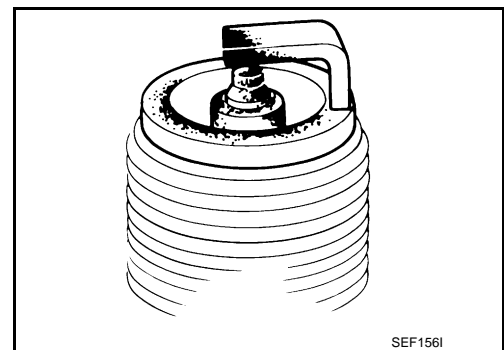
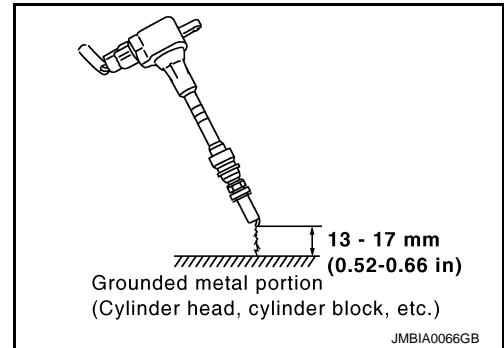

## 9.CHECK FUNCTION OF IGNITION COIL-III

1. Reconnect the initial spark plugs.
2. Crank engine for approximately 3 seconds, and recheck whether spark is generated between the spark plug and the grounded portion.

**Spark should be generated.**

Is the inspection result normal?

- YES >> INSPECTION END

## P0420, P0430 THREE WAY CATALYST FUNCTION

< DTC/CIRCUIT DIAGNOSIS >

[VK56VD FOR USA AND CANADA]

NO >> Replace spark plug(s) with standard type one(s). For spark plug type, refer to [MA-53, "SPARK PLUG \(VK56VD\) : Spark Plug"](#).

### 10.CHECK FUEL INJECTOR

1. Turn ignition switch OFF.
2. Remove fuel injector assembly. Refer to [EM-197, "Exploded View"](#). Keep fuel hose and all fuel injectors connected to fuel tube.
3. Disconnect all ignition coil harness connectors.
4. Reconnect all fuel injector harness connectors disconnected.
5. Turn ignition switch ON.
6. Check that fuel does not drip from fuel injector.

Does fuel drip from fuel injector?

YES >> Replace the fuel injector(s) from which fuel is dripping. Refer to [EM-197, "Removal and Installation"](#).

NO >> GO TO 11.

### 11.CHECK INTERMITTENT INCIDENT

Refer to [GI-44, "Intermittent Incident"](#).

Is the inspection result normal?

YES >> Replace three way catalyst assembly. Refer to [EM-223, "Exploded View"](#).

NO >> Repair or replace harness or connector.

# P0441 EVAP CONTROL SYSTEM

< DTC/CIRCUIT DIAGNOSIS >

[VK56VD FOR USA AND CANADA]

## P0441 EVAP CONTROL SYSTEM

### DTC Logic

INFOID:000000007187577

#### DTC DETECTION LOGIC

**NOTE:**

If DTC P0441 is displayed with other DTC such as P2122, P2123, P2127, P2128 or P2138, first perform trouble diagnosis for other DTC.

In this evaporative emission (EVAP) control system, purge flow occurs during non-closed throttle conditions. Purge volume is related to air intake volume. Under normal purge conditions (non-closed throttle), the EVAP canister purge volume control solenoid valve is open to admit purge flow. Purge flow exposes the EVAP control system pressure sensor to intake manifold vacuum.

Under normal conditions (non-closed throttle), sensor output voltage indicates if pressure drop and purge flow are adequate. If not, a malfunction is determined.

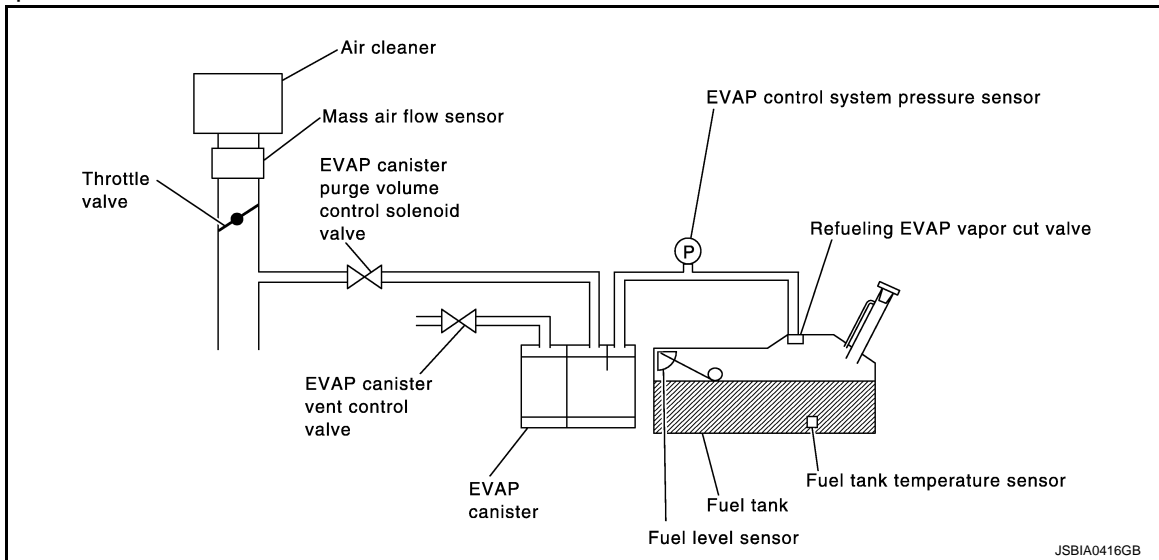

| DTC No. | Trouble diagnosis name<br>(Trouble diagnosis content)            | DTC detecting condition  | Possible cause   |
|---------|--|--|--|
| P0441   | EVAP PURG FLOW/MON<br>(EVAP control system incorrect purge flow) | EVAP control system does not operate properly, EVAP control system has a leak between intake manifold and EVAP control system pressure sensor. | <ul style="list-style-type: none"> <li>• EVAP canister purge volume control solenoid valve stuck closed</li> <li>• EVAP control system pressure sensor and the circuit</li> <li>• Loose, disconnected or improper connection of rubber tube</li> <li>• Blocked rubber tube</li> <li>• Cracked EVAP canister</li> <li>• EVAP canister purge volume control solenoid valve circuit</li> <li>• Accelerator pedal position sensor</li> <li>• Blocked purge port</li> <li>• EVAP canister vent control valve</li> </ul> |

#### DTC CONFIRMATION PROCEDURE

##### 1. PRECONDITIONING

If DTC Confirmation Procedure has been previously conducted, always perform the following procedure before conducting the next test.

1. Turn ignition switch OFF and wait at least 10 seconds.
2. Turn ignition switch ON.
3. Turn ignition switch OFF and wait at least 10 seconds.

##### Will CONSULT be used?

- YES >> GO TO 2.  
NO >> GO TO 5.

# P0441 EVAP CONTROL SYSTEM

< DTC/CIRCUIT DIAGNOSIS >

[VK56VD FOR USA AND CANADA]

## 2. PERFORM DTC CONFIRMATION PROCEDURE-I

 WITH CONSULT

### TESTING CONDITION:

Always perform test at a temperature of 5°C (41°F) or more.

1. Start engine and warm it up to normal operating temperature.
2. Turn ignition switch OFF and wait at least 10 seconds.
3. Turn ignition switch ON.
4. Turn ignition switch OFF and wait at least 10 seconds.
5. Start engine and let it idle for at least 70 seconds.
6. Select "PURG FLOW P0441" of "EVAPORATIVE SYSTEM" in "DTC WORK SUPPORT" mode with CONSULT.
7. Touch "START".

Is "COMPLETED" displayed on CONSULT screen?

- YES >> GO TO 4.  
NO >> GO TO 3.

## 3. PERFORM DTC CONFIRMATION PROCEDURE-II

When the following conditions are met, "TESTING" will be displayed on the CONSULT screen. Maintain the conditions continuously until "TESTING" changes to "COMPLETED". (It will take at least 35 seconds.)

|                |                             |
|----------------|-----------------------------|
| Selector lever | Suitable position           |
| VHCL SPEED SE  | 32 - 120 km/h (20 - 75 MPH) |
| ENG SPEED      | 500 - 3,000 rpm             |
| B/FUEL SCHDL   | 1.3 - 9.0 msec              |
| COOLAN TEMP/S  | More than 0°C (32°F)        |

### CAUTION:

Always drive vehicle at a safe speed.

### NOTE:

If "TESTING" does not change for a long time, retry from step 2.

Is "COMPLETED" displayed on CONSULT screen?

- YES >> GO TO 4.  
NO >> Perform DTC CONFIRMATION PROCEDURE again. GO TO 2.

## 4. PERFORM DTC CONFIRMATION PROCEDURE-III

Touch "SELF-DIAG RESULTS".

Which is displayed on CONSULT screen?

- OK >> INSPECTION END  
NG >> Proceed to [EC-1321, "Diagnosis Procedure"](#).

## 5. PERFORM COMPONENT FUNCTION CHECK

 WITH GST

Perform component function check. Refer to [EC-1320, "Component Function Check"](#).

### NOTE:

Use component function check to check the overall monitoring function of the EVAP control system purge flow monitoring. During this check, a 1st trip DTC might not be confirmed.

Is the inspection result normal?

- YES >> INSPECTION END  
NO >> Proceed to [EC-1321, "Diagnosis Procedure"](#).

## Component Function Check

INFOID:000000007187578

## 1. PERFORM COMPONENT FUNCTION CHECK

 WITH GST

1. Lift up drive wheels.
2. Start engine (VDC switch OFF) and warm it up to normal operating temperature.



# P0441 EVAP CONTROL SYSTEM

[VK56VD FOR USA AND CANADA]

## < DTC/CIRCUIT DIAGNOSIS >

- Turn ignition switch OFF and wait at least 10 seconds.
- Start engine and wait at least 70 seconds.
- Set voltmeter probes to ECM harness connector terminals under the following conditions.

| ECM       |   |          |
|-----------|---|----------|
| Connector | +   | -        |
|           | Terminal  | Terminal |
| M160      | 143<br>(EVAP control system pressure sensor signal) | 150      |

- Check EVAP control system pressure sensor value at idle speed and note it.
- Establish and maintain the following conditions for at least 1 minute.

|                             |                                   |
|-----------------------------|-----------------------------------|
| Air conditioner switch      | ON                                |
| Headlamp switch             | ON                                |
| Rear window defogger switch | ON                                |
| Engine speed                | Approx. 3,000 rpm                 |
| Gear position               | Any position other than P, N or R |

- Verify that EVAP control system pressure sensor value stays 0.1 V less than the value at idle speed (measured at step 6) for at least 1 second.

### Is the inspection result normal?

- YES >> INSPECTION END  
NO >> Proceed to [EC-1321, "Diagnosis Procedure"](#).

## Diagnosis Procedure

INFOID:000000007187579

### 1.CHECK EVAP CANISTER

- Turn ignition switch OFF.
- Check EVAP canister for cracks.

### Is the inspection result normal?

- YES-1 >> With CONSULT: GO TO 2.  
YES-2 >> Without CONSULT: GO TO 3.  
NO >> Replace EVAP canister. Refer to [FL-16, "Removal and Installation"](#).

### 2.CHECK PURGE FLOW

#### WITH CONSULT

- Disconnect vacuum hose connected to EVAP canister purge volume control solenoid valve at EVAP service port.
- Start engine and let it idle.
- Select "PURG VOL CONT/V" in "ACTIVE TEST" mode with CONSULT.
- Touch "Qd" and "Qu" on CONSULT screen to adjust "PURG VOL CONT/V" opening and check vacuum existence.

|                 |             |
|-----------------|-------------|
| PURG VOL CONT/V | Vacuum      |
| 100%            | Existed     |
| 0%              | Not existed |

### Is the inspection result normal?

- YES >> GO TO 7.  
NO >> GO TO 4.

### 3.CHECK PURGE FLOW

#### WITHOUT CONSULT

- Start engine and warm it up to normal operating temperature.
- Stop engine.

# P0441 EVAP CONTROL SYSTEM

[VK56VD FOR USA AND CANADA]

## < DTC/CIRCUIT DIAGNOSIS >

3. Disconnect vacuum hose connected to EVAP canister purge volume control solenoid valve at EVAP service port and install vacuum gauge. For the location of EVAP service port, refer to [EC-1022, "EVAPORATIVE EMISSION SYSTEM : System Description"](#).
4. Start engine and let it idle.  
**Never depress accelerator pedal even slightly.**
5. Check vacuum gauge indication before 60 seconds pass after starting engine.

**Vacuum should not exist.**

6. Rev engine up to 2,000 rpm after 100 seconds pass after starting engine.

**Vacuum should exist.**

Is the inspection result normal?

- YES >> GO TO 7.  
NO >> GO TO 4.

## 4.CHECK EVAP PURGE LINE

1. Turn ignition switch OFF.
2. Check EVAP purge line for improper connection or disconnection.  
Refer to [FL-15, "VK56VD : Hydraulic Layout"](#).

Is the inspection result normal?

- YES >> GO TO 5.  
NO >> Repair EVAP purge line.

## 5.CHECK EVAP PURGE HOSE AND PURGE PORT

1. Disconnect purge hoses connected to EVAP service port (A) and EVAP canister purge volume control solenoid valve (B).
2. Blow air into each hose and EVAP purge port (C).

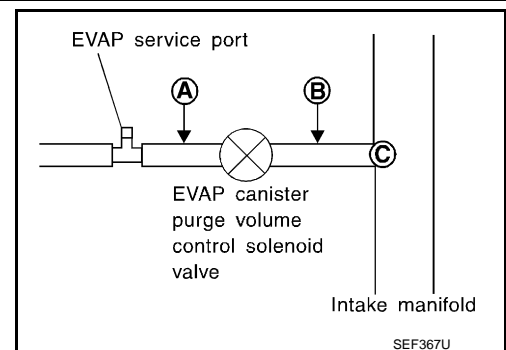

3. Check that air flows freely.

Is the inspection result normal?

- YES-1 >> With CONSULT: GO TO 6.  
YES-2 >> Without CONSULT: GO TO 7.  
NO >> Repair or clean hoses and/or purge port.

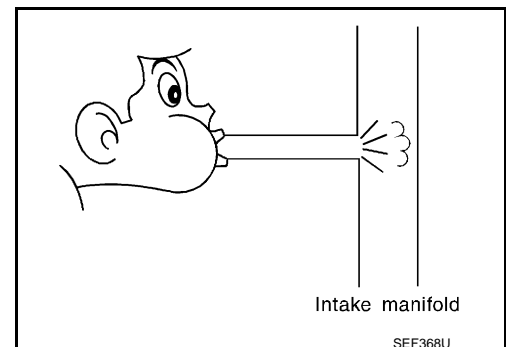

## 6.CHECK EVAP CANISTER PURGE VOLUME CONTROL SOLENOID VALVE

Ⓟ WITH CONSULT

1. Start engine.
2. Perform "PURG VOL CONT/V" in "ACTIVE TEST" mode with CONSULT. Check that engine speed varies according to the valve opening.

Does engine speed vary according to the valve opening?

- YES >> GO TO 8.  
NO >> GO TO 7.

# P0441 EVAP CONTROL SYSTEM

[VK56VD FOR USA AND CANADA]

< DTC/CIRCUIT DIAGNOSIS >

## 7. CHECK EVAP CANISTER PURGE VOLUME CONTROL SOLENOID VALVE

Refer to [EC-1327, "Component Inspection \(EVAP Canister Purge Volume Control Solenoid Valve\)"](#).

Is the inspection result normal?

YES >> GO TO 8.

NO >> Replace EVAP canister purge volume control solenoid valve. Refer to [FL-13, "Exploded View"](#).

## 8. CHECK EVAP CONTROL SYSTEM PRESSURE SENSOR CONNECTOR

1. Disconnect EVAP control system pressure sensor harness connector.

2. Check that water is not inside connectors.

Is the inspection result normal?

YES >> GO TO 9.

NO >> Replace EVAP control system pressure sensor. Refer to [FL-13, "Exploded View"](#).

## 9. CHECK EVAP CONTROL SYSTEM PRESSURE SENSOR FUNCTION

Refer to [EC-1344, "DTC Logic"](#) for DTC P0452, [EC-1349, "DTC Logic"](#) for DTC P0453.

Is the inspection result normal?

YES >> GO TO 10.

NO >> Replace EVAP control system pressure sensor. Refer to [FL-13, "Exploded View"](#).

## 10. CHECK RUBBER TUBE FOR CLOGGING

1. Disconnect rubber tube connected to EVAP canister vent control valve.

2. Check the rubber tube for clogging.

Is the inspection result normal?

YES >> GO TO 11.

NO >> Clean the rubber tube using an air blower.

## 11. CHECK EVAP CANISTER VENT CONTROL VALVE

Refer to [EC-1334, "Component Inspection \(EVAP Canister Vent Control Valve\)"](#).

Is the inspection result normal?

YES >> GO TO 12.

NO >> Replace EVAP canister vent control valve. Refer to [FL-13, "Exploded View"](#).

## 12. CHECK EVAP PURGE LINE

Inspect EVAP purge line (pipe and rubber tube). Check for evidence of leaks.

Refer to [FL-15, "VK56VD : Hydraulic Layout"](#).

Is the inspection result normal?

YES >> GO TO 13.

NO >> Repair or replace malfunctioning part.

## 13. CLEAN EVAP PURGE LINE

Clean EVAP purge line (pipe and rubber tube) using air blower.

>> GO TO 14.

## 14. CHECK INTERMITTENT INCIDENT

Refer to [GI-44, "Intermittent Incident"](#).

>> INSPECTION END

A  
EC  
C  
D  
E  
F  
G  
H  
I  
J  
K  
L  
M  
N  
O  
P

# P0443 EVAP CANISTER PURGE VOLUME CONTROL SOLENOID VALVE

< DTC/CIRCUIT DIAGNOSIS >

[VK56VD FOR USA AND CANADA]

## P0443 EVAP CANISTER PURGE VOLUME CONTROL SOLENOID VALVE

### DTC Logic

INFOID:000000007187580

### DTC DETECTION LOGIC

| DTC No. | Trouble diagnosis name<br>(Trouble diagnosis content)                     | DTC detecting condition |  | Possible cause  |
|---------|---|-------------------------|--|---|
| P0443   | PURG VOLUME CONT/V<br>(EVAP canister purge volume control solenoid valve) | A                       | The canister purge flow is detected during the vehicle is stopped while the engine is running, even when EVAP canister purge volume control solenoid valve is completely closed. | <ul style="list-style-type: none"><li>• EVAP control system pressure sensor</li><li>• EVAP canister purge volume control solenoid valve<br/>(The valve is stuck open.)</li><li>• EVAP canister vent control valve</li><li>• EVAP canister</li><li>• Hoses<br/>(Hoses are connected incorrectly or clogged.)</li></ul> |
|         |   | B                       | The canister purge flow is detected during the specified driving conditions, even when EVAP canister purge volume control solenoid valve is completely closed.                   |   |

### DTC CONFIRMATION PROCEDURE

#### 1. PRECONDITIONING

If DTC Confirmation Procedure has been previously conducted, always perform the following procedure before conducting the next test.

1. Turn ignition switch OFF and wait at least 10 seconds.
2. Turn ignition switch ON.
3. Turn ignition switch OFF and wait at least 10 seconds.

#### TESTING CONDITION:

- Perform “DTC CONFIRMATION PROCEDURE” when the fuel level is between 1/4 and 3/4 full, and vehicle is placed on flat level surface.
- Always perform test at a temperature of 5 to 60°C (41 to 140°F).
- Cool the vehicle so that engine coolant temperature becomes same level as ambient temperature.

#### Do you have CONSULT

- YES >> GO TO 2.  
NO >> GO TO 4.

#### 2. PERFORM DTC CONFIRMATION PROCEDURE A

##### Ⓜ WITH CONSULT

1. Turn ignition switch ON.
2. Check that the following condition are met.  
FUEL T/TMP SE: 0 - 35°C (32 - 95°F)
3. Start engine and wait at least 60 seconds.
4. Check 1st trip DTC.

#### IS 1st trip DTC detected?

- OK >> Proceed to [EC-1325, "Diagnosis Procedure"](#).  
NG >> GO TO 3.

#### 3. PERFORM DTC CONFIRMATION PROCEDURE B

##### Ⓜ WITH CONSULT

1. Start engine and warm it up to normal operating temperature.
2. Turn ignition switch OFF and wait at least 10 seconds.
3. Turn ignition switch ON.
4. Turn ignition switch OFF and wait at least 10 seconds.
5. Turn ignition switch ON.
6. Select “PURG VOL CN/V P1444” of “EVAPORATIVE SYSTEM” in “DTC WORK SUPPORT” mode with CONSULT.
7. Touch “START”.
8. Start engine and let it idle until “TESTING” on CONSULT changes to “COMPLETED”. (It will take approximately 10 seconds.)

If “TESTING” is not displayed after 5 minutes, retry from step 2.

# P0443 EVAP CANISTER PURGE VOLUME CONTROL SOLENOID VALVE

< DTC/CIRCUIT DIAGNOSIS >

[VK56VD FOR USA AND CANADA]

9. Touch "SELF-DIAG RESULTS".

Which is displayed on CONSULT screen?

- OK >> INSPECTION END
- NG >> Proceed to [EC-1325, "Diagnosis Procedure"](#).

## 4.PERFORM DTC CONFIRMATION PROCEDURE A

 WITH GST

1. Turn ignition switch ON.
2. Set voltmeter probes to ECM harness connector terminals.

| Connector | ECM  |                        | Voltage (V) |
|-----------|--|------------------------|-------------|
|           | +  | -                      |             |
|           | Terminal                                     | Terminal               |             |
| M160      | 134<br>(Fuel tank temperature sensor signal) | 175<br>(Sensor ground) | 3.1 - 4.0   |

3. Start engine and wait at least 60 seconds.
4. Check 1st trip DTC.

Is 1st trip DTC detected?

- YES >> Proceed to [EC-1325, "Diagnosis Procedure"](#).
- NO >> GO TO 5.

## 5.PERFORM DTC CONFIRMATION PROCEDURE B

 WITH GST

1. Start engine and warm it up to normal operating temperature.
2. Turn ignition switch OFF and wait at least 10 seconds.
3. Turn ignition switch ON.
4. Turn ignition switch OFF and wait at least 10 seconds.
5. Start engine and let it idle for at least 20 seconds.
6. Check 1st trip DTC.

Is 1st trip DTC displayed?

- YES >> Proceed to [EC-1325, "Diagnosis Procedure"](#).
- NO >> INSPECTION END

## Diagnosis Procedure

INFOID:000000007187581

### 1.CHECK EVAP CANISTER PURGE VOLUME CONTROL SOLENOID VALVE POWER SUPPLY CIRCUIT

1. Turn ignition switch OFF.
2. Disconnect EVAP canister purge volume control solenoid valve harness connector.
3. Turn ignition switch ON.
4. Check the voltage between EVAP canister purge volume control solenoid valve harness connector and ground.

| EVAP canister purge volume control solenoid valve |          | Ground | Voltage         |
|---|----------|--------|-----------------|
| Connector   | Terminal |        |                 |
| F10   | 1        | Ground | Battery voltage |

Is the inspection result normal?

- YES >> GO TO 3.
- NO >> GO TO 2.

### 2.DETECT MALFUNCTIONING PART

Check the following.

- Harness for open or short between EVAP canister purge volume control solenoid valve and IPDM E/R
- Harness for open or short between EVAP canister purge volume control solenoid valve and ECM
- Loose or poor connection for each connector and harness

# P0443 EVAP CANISTER PURGE VOLUME CONTROL SOLENOID VALVE

< DTC/CIRCUIT DIAGNOSIS >

[VK56VD FOR USA AND CANADA]

>> Repair open circuit, short to ground or short to power in harness or connectors.

## 3. CHECK EVAP CANISTER PURGE VOLUME CONTROL SOLENOID VALVE OUTPUT SIGNAL CIRCUIT FOR OPEN AND SHORT

1. Turn ignition switch OFF.
2. Disconnect ECM harness connector.
3. Check the continuity between EVAP canister purge volume control solenoid valve harness connector and ECM harness connector.

| EVAP canister purge volume control solenoid valve |          | ECM       |          | Continuity |
|---|----------|-----------|----------|------------|
| Connector   | Terminal | Connector | Terminal |            |
| F10   | 2        | F111      | 64       | Existed    |

4. Also check harness for short to ground and short to power.

Is the inspection result normal?

YES >> GO TO 4.

NO >> Repair open circuit, short to ground or short to power in harness or connectors.

## 4. CHECK EVAP CONTROL SYSTEM PRESSURE SENSOR CONNECTOR

1. Disconnect EVAP control system pressure sensor harness connector.
2. Check that water is not inside connectors.

Is the inspection result normal?

YES >> GO TO 5.

NO >> Replace EVAP control system pressure sensor. Refer to [FL-13, "Exploded View"](#).

## 5. CHECK EVAP CONTROL SYSTEM PRESSURE SENSOR

Refer to [EC-1343, "Component Inspection \(EVAP Control System Pressure Sensor\)"](#).

Is the inspection result normal?

YES-1 >> With CONSULT: GO TO 6.

YES-2 >> Without CONSULT: GO TO 7.

NO >> Replace EVAP control system pressure sensor. Refer to [FL-13, "Exploded View"](#).

## 6. CHECK EVAP CANISTER PURGE VOLUME CONTROL SOLENOID VALVE

Ⓟ WITH CONSULT

1. Turn ignition switch OFF.
2. Reconnect harness connectors disconnected.
3. Start engine.
4. Perform "PURG VOL CONT/V" in "ACTIVE TEST" mode with CONSULT. Check that engine speed varies according to the valve opening.

Does engine speed vary according to the valve opening?

YES >> GO TO 8.

NO >> GO TO 7.

## 7. CHECK EVAP CANISTER PURGE VOLUME CONTROL SOLENOID VALVE

Refer to [EC-1327, "Component Inspection \(EVAP Canister Purge Volume Control Solenoid Valve\)"](#).

Is the inspection result normal?

YES >> GO TO 8.

NO >> Replace EVAP canister purge volume control solenoid valve. Refer to [FL-13, "Exploded View"](#).

## 8. CHECK RUBBER TUBE FOR CLOGGING

1. Disconnect rubber tube connected to EVAP canister vent control valve.
2. Check the rubber tube for clogging.

Is the inspection result normal?

YES >> GO TO 9.

NO >> Clean the rubber tube using an air blower.

## 9. CHECK EVAP CANISTER VENT CONTROL VALVE

# P0443 EVAP CANISTER PURGE VOLUME CONTROL SOLENOID VALVE

[VK56VD FOR USA AND CANADA]

< DTC/CIRCUIT DIAGNOSIS >

Refer to [EC-1334, "Component Inspection \(EVAP Canister Vent Control Valve\)"](#).

Is the inspection result normal?

YES >> GO TO 10.

NO >> Replace EVAP canister vent control valve. Refer to [FL-13, "Exploded View"](#).

## 10. CHECK IF EVAP CANISTER IS SATURATED WITH WATER

1. Remove EVAP canister with EVAP canister vent control valve and EVAP control system pressure sensor attached. Refer to [FL-13, "Exploded View"](#).
2. Check if water will drain from EVAP canister (1).
  - EVAP canister vent control valve (2)

Does water drain from the EVAP canister?

YES >> GO TO 11.

NO >> GO TO 13.

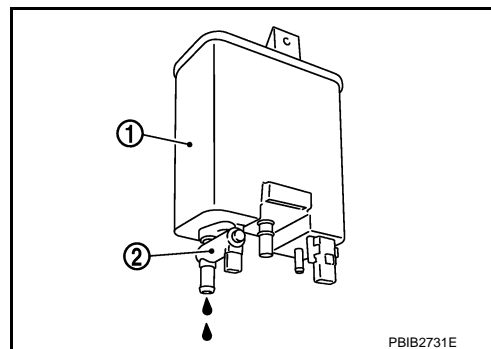

## 11. CHECK EVAP CANISTER

Weigh the EVAP canister with the EVAP canister vent control valve and EVAP control system pressure sensor attached.

**The weight should be less than 2.1 kg (4.6 lb).**

Is the inspection result normal?

YES >> GO TO 13.

NO >> GO TO 12.

## 12. DETECT MALFUNCTIONING PART

Check the following.

- EVAP canister for damage
- EVAP hose between EVAP canister and vehicle frame for clogging or poor connection

>> Repair hose or replace EVAP canister. Refer to [FL-15, "VK56VD : Hydraulic Layout"](#).

## 13. CHECK INTERMITTENT INCIDENT

Refer to [GI-44, "Intermittent Incident"](#).

>> INSPECTION END

## Component Inspection (EVAP Canister Purge Volume Control Solenoid Valve)

INFOID:000000007187582

## 1. CHECK EVAP CANISTER PURGE VOLUME CONTROL SOLENOID VALVE

Ⓜ WITH CONSULT

1. Turn ignition switch OFF.
2. Reconnect all harness connectors disconnected.
3. Disconnect EVAP purge hoses connected to EVAP canister purge volume control solenoid valve.
4. Turn ignition switch ON.
5. Select "PURG VOL CONT/V" in "ACTIVE TEST" mode with CONSULT.

# P0443 EVAP CANISTER PURGE VOLUME CONTROL SOLENOID VALVE

[VK56VD FOR USA AND CANADA]

## < DTC/CIRCUIT DIAGNOSIS >

6. Touch “Qd” and “Qu” on CONSULT screen to adjust “PURG VOL C/V” opening and check air passage continuity of EVAP canister purge volume control solenoid valve under the following conditions.

| Condition<br>(PURG VOL C/V value) | Air passage continuity<br>between (A) and (B) |
|-----------------------------------|---|
| 100%                              | Existed                                       |
| 0%                                | Not existed                                   |

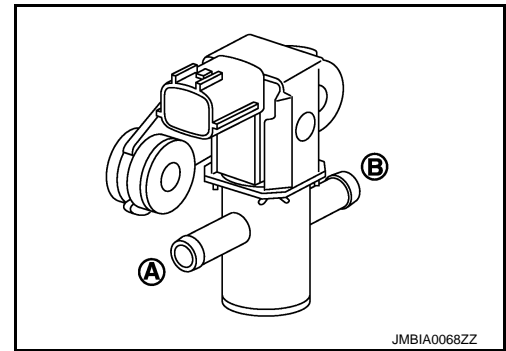

### ⊗ WITHOUT CONSULT

1. Turn ignition switch OFF.
2. Disconnect EVAP canister purge volume control solenoid valve harness connector.
3. Disconnect EVAP purge hoses connected to EVAP canister purge volume control solenoid valve.
4. Check air passage continuity of EVAP canister purge volume control solenoid valve under the following conditions.

| Condition   | Air passage continuity<br>between (A) and (B) |
|---|---|
| 12 V direct current supply between<br>terminals 1 and 2 | Existed                                       |
| No supply   | Not existed                                   |

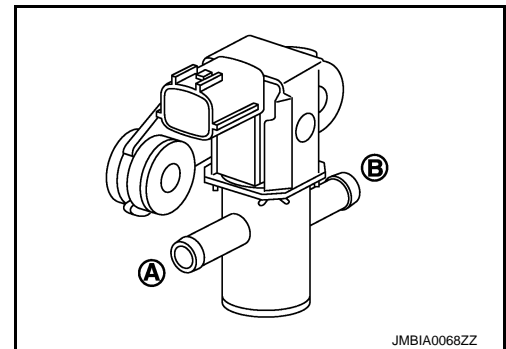

### Is the inspection result normal?

YES >> INSPECTION END

NO >> Replace EVAP canister purge volume control solenoid valve. Refer to [FL-15. "VK56VD : Hydraulic Layout"](#).



# P0444, P0445 EVAP CANISTER PURGE VOLUME CONTROL SOLENOID VALVE

< DTC/CIRCUIT DIAGNOSIS >

[VK56VD FOR USA AND CANADA]

## P0444, P0445 EVAP CANISTER PURGE VOLUME CONTROL SOLENOID VALVE

### DTC Logic

INFOID:000000007187583

### DTC DETECTION LOGIC

| DTC No. | Trouble diagnosis name (Trouble diagnosis content)                                     | DTC detecting condition   | Possible cause  |
|---------|--|---|---|
| P0444   | PURG VOLUME CONT/V (EVAP canister purge volume control solenoid valve circuit open)    | An excessively low voltage signal is sent to ECM through the valve  | <ul style="list-style-type: none"> <li>Harness or connectors (The solenoid valve circuit is open or shorted.)</li> <li>EVAP canister purge volume control solenoid valve</li> </ul> |
| P0445   | PURG VOLUME CONT/V (EVAP canister purge volume control solenoid valve circuit shorted) | An excessively high voltage signal is sent to ECM through the valve | <ul style="list-style-type: none"> <li>Harness or connectors (The solenoid valve circuit is shorted.)</li> <li>EVAP canister purge volume control solenoid valve</li> </ul>         |

### DTC CONFIRMATION PROCEDURE

#### 1. PRECONDITIONING

- Turn ignition switch OFF and wait at least 10 seconds.
- Turn ignition switch ON.
- Turn ignition switch OFF and wait at least 10 seconds.

#### TESTING CONDITION:

Before performing the following procedure, confirm battery voltage is 11 V or more at idle.

>> GO TO 2.

#### 2. PERFORM DTC CONFIRMATION PROCEDURE

- Start engine and let it idle for at least 13 seconds.
- Check 1st trip DTC.

#### Is 1st trip DTC detected?

YES >> Proceed to [EC-1329, "Diagnosis Procedure"](#).

NO >> INSPECTION END

### Diagnosis Procedure

INFOID:000000007187584

#### 1. CHECK EVAP CANISTER PURGE VOLUME CONTROL SOLENOID VALVE POWER SUPPLY CIRCUIT

- Turn ignition switch OFF.
- Disconnect EVAP canister purge volume control solenoid valve harness connector.
- Turn ignition switch ON.
- Check the voltage between EVAP canister purge volume control solenoid valve harness connector and ground.

| EVAP canister purge volume control solenoid valve |          | Ground | Voltage         |
|---|----------|--------|-----------------|
| Connector   | Terminal |        |                 |
| F10   | 1        | Ground | Battery voltage |

#### Is the inspection result normal?

YES >> GO TO 3.

NO >> GO TO 2.

#### 2. DETECT MALFUNCTIONING PART

Check the following.

- Loose or poor connection for each connector and harness
- Harness for open or short between EVAP canister purge volume control solenoid valve and IPDM E/R

# P0444, P0445 EVAP CANISTER PURGE VOLUME CONTROL SOLENOID VALVE

< DTC/CIRCUIT DIAGNOSIS >

[VK56VD FOR USA AND CANADA]

- Harness for open or short between EVAP canister purge volume control solenoid valve and ECM

>> Repair open circuit, short to ground or short to power in harness or connectors.

## 3. CHECK EVAP CANISTER PURGE VOLUME CONTROL SOLENOID VALVE OUTPUT SIGNAL CIRCUIT FOR OPEN AND SHORT

1. Turn ignition switch OFF.
2. Disconnect ECM harness connector.
3. Check the continuity between EVAP canister purge volume control solenoid valve harness connector and ECM harness connector.

| EVAP canister purge volume control solenoid valve |          | ECM       |          | Continuity |
|---|----------|-----------|----------|------------|
| Connector   | Terminal | Connector | Terminal |            |
| F10   | 2        | F111      | 64       | Existed    |

4. Also check harness for short to ground and short to power.

Is the inspection result normal?

YES-1 >> With CONSULT: GO TO 4.

YES-2 >> Without CONSULT: GO TO 5.

NO >> Repair open circuit, short to ground or short to power in harness or connectors.

## 4. CHECK EVAP CANISTER PURGE VOLUME CONTROL SOLENOID VALVE OPERATION

Ⓟ WITH CONSULT

1. Reconnect all harness connectors disconnected.
2. Start engine.
3. Perform "PURG VOL CONT/V" in "ACTIVE TEST" mode with CONSULT. Check that engine speed varies according to the valve opening.

Does engine speed vary according to the valve opening?

YES >> GO TO 6.

NO >> GO TO 5.

## 5. CHECK EVAP CANISTER PURGE VOLUME CONTROL SOLENOID VALVE

Refer to [EC-1330, "Component Inspection \(EVAP Canister Purge Volume Control Solenoid Valve\)"](#).

Is the inspection result normal?

YES >> GO TO 6.

NO >> Replace EVAP canister purge volume control solenoid valve. Refer to [FL-13, "Exploded View"](#).

## 6. CHECK INTERMITTENT INCIDENT

Refer to [GI-44, "Intermittent Incident"](#).

>> INSPECTION END

## Component Inspection (EVAP Canister Purge Volume Control Solenoid Valve)

INFOID:000000007187585

## 1. CHECK EVAP CANISTER PURGE VOLUME CONTROL SOLENOID VALVE

Ⓟ WITH CONSULT

1. Turn ignition switch OFF.
2. Reconnect all harness connectors disconnected.
3. Disconnect EVAP purge hoses connected to EVAP canister purge volume control solenoid valve.
4. Turn ignition switch ON.
5. Select "PURG VOL CONT/V" in "ACTIVE TEST" mode with CONSULT.

# P0444, P0445 EVAP CANISTER PURGE VOLUME CONTROL SOLENOID VALVE

< DTC/CIRCUIT DIAGNOSIS >

[VK56VD FOR USA AND CANADA]

6. Touch "Qd" and "Qu" on CONSULT screen to adjust "PURG VOL C/V" opening and check air passage continuity of EVAP canister purge volume control solenoid valve under the following conditions.

| Condition<br>(PURG VOL C/V value) | Air passage continuity<br>between (A) and (B) |
|-----------------------------------|---|
| 100%                              | Existed                                       |
| 0%                                | Not existed                                   |

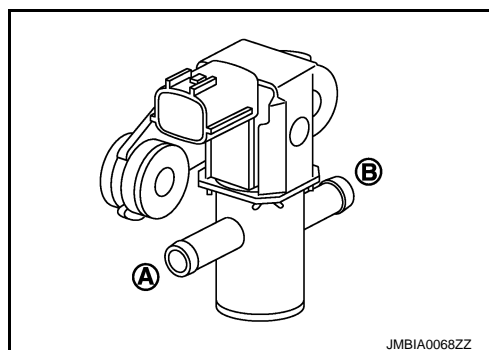

**⊗ WITHOUT CONSULT**

1. Turn ignition switch OFF.
2. Disconnect EVAP canister purge volume control solenoid valve harness connector.
3. Disconnect EVAP purge hoses connected to EVAP canister purge volume control solenoid valve.
4. Check air passage continuity of EVAP canister purge volume control solenoid valve under the following conditions.

| Condition   | Air passage continuity<br>between (A) and (B) |
|---|---|
| 12 V direct current supply between<br>terminals 1 and 2 | Existed                                       |
| No supply   | Not existed                                   |

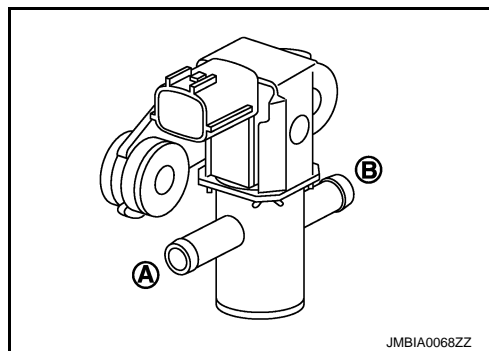

Is the inspection result normal?

YES >> INSPECTION END

NO >> Replace EVAP canister purge volume control solenoid valve. Refer to [FL-15. "VK56VD : Hydraulic Layout"](#).

A  
EC  
C  
D  
E  
F  
G  
H  
I  
J  
K  
L  
M  
N  
O  
P

# P0447 EVAP CANISTER VENT CONTROL VALVE

< DTC/CIRCUIT DIAGNOSIS >

[VK56VD FOR USA AND CANADA]

## P0447 EVAP CANISTER VENT CONTROL VALVE

### DTC Logic

INFOID:000000007187586

### DTC DETECTION LOGIC

| DTC No. | Trouble diagnosis name<br>(Trouble diagnosis content)                 | DTC detecting condition   | Possible cause   |
|---------|---|---|--|
| P0447   | VENT CONTROL VALVE<br>(EVAP canister vent control valve circuit open) | An improper voltage signal is sent to ECM through EVAP canister vent control valve. | <ul style="list-style-type: none"><li>• Harness or connectors<br/>(The valve circuit is open or shorted.)</li><li>• EVAP canister vent control valve</li></ul> |

### DTC CONFIRMATION PROCEDURE

#### 1. PRECONDITIONING

1. Turn ignition switch OFF and wait at least 10 seconds.
2. Turn ignition switch ON.
3. Turn ignition switch OFF and wait at least 10 seconds.

#### TESTING CONDITION:

**Before performing the following procedure, confirm battery voltage is 11 V or more at idle.**

>> GO TO 2.

#### 2. PERFORM DTC CONFIRMATION PROCEDURE

1. Start engine and wait at least 8 seconds.
2. Check 1st trip DTC.

#### Is 1st trip DTC detected?

- YES >> Proceed to [EC-1332, "Diagnosis Procedure"](#).  
NO >> INSPECTION END

### Diagnosis Procedure

INFOID:000000007187587

#### 1. INSPECTION START

Will CONSULT be used?

Will CONSULT be used?

- YES >> GO TO 2.  
NO >> GO TO 3.

#### 2. CHECK EVAP CANISTER VENT CONTROL VALVE CIRCUIT

##### WITH CONSULT

1. Turn ignition switch OFF and then ON.
2. Select "VENT CONTROL/V" in "ACTIVE TEST" mode with CONSULT.
3. Touch "ON/OFF" on CONSULT screen.
4. Check for operating sound of the valve.

**Clicking sound should be heard.**

#### Is the inspection result normal?

- YES >> GO TO 7.  
NO >> GO TO 3.

#### 3. CHECK EVAP CANISTER VENT CONTROL VALVE POWER SUPPLY CIRCUIT

1. Turn ignition switch OFF.
2. Disconnect EVAP canister vent control valve harness connector.
3. Turn ignition switch ON.
4. Check the voltage between EVAP canister vent control valve harness connector and ground.

# P0447 EVAP CANISTER VENT CONTROL VALVE

< DTC/CIRCUIT DIAGNOSIS >

[VK56VD FOR USA AND CANADA]

| EVAP canister vent control valve |          | Ground | Voltage         |
|----------------------------------|----------|--------|-----------------|
| Connector                        | Terminal |        |                 |
| B74                              | 1        | Ground | Battery voltage |

Is the inspection result normal?

YES >> GO TO 5.

NO >> GO TO 4.

## 4. DETECT MALFUNCTIONING PART

Check the following.

- Harness for open or short between EVAP canister vent control valve and IPDM E/R
- Loose or poor connection for each connector and harness

>> Repair open circuit, short to ground or short to power in harness or connectors.

## 5. CHECK EVAP CANISTER VENT CONTROL VALVE OUTPUT SIGNAL CIRCUIT FOR OPEN AND SHORT

1. Turn ignition switch OFF.
2. Disconnect ECM harness connector.
3. Check the continuity between EVAP canister vent control valve harness connector and ECM harness connector.

| EVAP canister vent control valve |          | ECM       |          | Continuity |
|----------------------------------|----------|-----------|----------|------------|
| Connector                        | Terminal | Connector | Terminal |            |
| B74                              | 2        | M160      | 120      | Existed    |

4. Also check harness for short to ground and short to power.

Is the inspection result normal?

YES >> GO TO 7.

NO >> GO TO 6.

## 6. DETECT MALFUNCTIONING PART

Check the following.

- Loose or poor connection for each connector and harness
- Harness for open or short between EVAP canister vent control valve and ECM

>> Repair open circuit, short to ground or short to power in harness or connectors.

## 7. CHECK RUBBER TUBE FOR CLOGGING

1. Disconnect rubber tube connected to EVAP canister vent control valve.
2. Check the rubber tube for clogging.

Is the inspection result normal?

YES >> GO TO 8.

NO >> Clean the rubber tube using an air blower.

## 8. CHECK EVAP CANISTER VENT CONTROL VALVE

Refer to [EC-1334, "Component Inspection \(EVAP Canister Vent Control Valve\)"](#).

Is the inspection result normal?

YES >> GO TO 9.

NO >> Replace EVAP canister vent control valve. Refer to [FL-13, "Exploded View"](#).

## 9. CHECK INTERMITTENT INCIDENT

Refer to [GI-44, "Intermittent Incident"](#).

>> INSPECTION END

# P0447 EVAP CANISTER VENT CONTROL VALVE

[VK56VD FOR USA AND CANADA]

< DTC/CIRCUIT DIAGNOSIS >

INFOID:000000007187588

## Component Inspection (EVAP Canister Vent Control Valve)

### 1. CHECK EVAP CANISTER VENT CONTROL VALVE-I

1. Turn ignition switch OFF.
2. Remove EVAP canister vent control valve from EVAP canister. Refer to [FL-13, "Exploded View"](#).
3. Check portion (A) of EVAP canister vent control valve for rust.

Is it rusted?

- YES >> Replace EVAP canister vent control valve. [FL-13, "Exploded View"](#).
- NO >> GO TO 2.

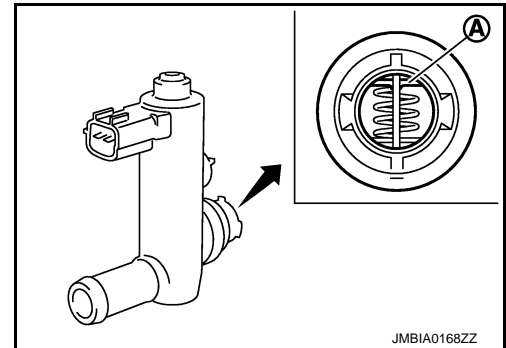

### 2. CHECK EVAP CANISTER VENT CONTROL VALVE-II

#### Ⓟ WITH CONSULT

1. Reconnect harness connectors disconnected.
2. Turn ignition switch ON.
3. Perform "VENT CONTROL/V" in "ACTIVE TEST" mode.
4. Check air passage continuity and operation delay time.  
**Check that new O-ring is installed properly.**

| VENT CONTROL/V Condition | Air passage continuity between (A) and (B) |
|--------------------------|--|
| ON                       | Not existed                                |
| OFF                      | Existed                                    |

Operation takes less than 1 second.

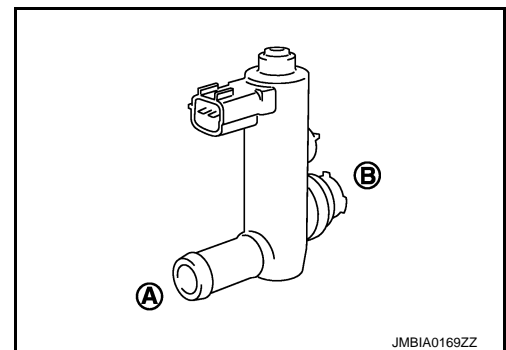

#### ⓧ WITHOUT CONSULT

1. Disconnect EVAP canister vent control valve harness connector.
2. Check air passage continuity and operation delay time under the following conditions.  
**Check that new O-ring is installed properly.**

| Condition  | Air passage continuity between (A) and (B) |
|--|--|
| 12 V direct current supply between terminals 1 and 2 | Not existed                                |
| OFF  | Existed                                    |

Operation takes less than 1 second.

Is the inspection result normal?

- YES >> GO TO 3.
- NO >> Replace EVAP canister vent control valve. Refer to [FL-13, "Exploded View"](#).

### 3. CHECK EVAP CANISTER VENT CONTROL VALVE-III

#### Ⓟ WITH CONSULT

1. Clean the air passage [portion (A) to (B)] of EVAP canister vent control valve using an air blower.
2. Perform "VENT CONTROL/V" in "ACTIVE TEST" mode.

# P0447 EVAP CANISTER VENT CONTROL VALVE

[VK56VD FOR USA AND CANADA]

## < DTC/CIRCUIT DIAGNOSIS >

3. Check air passage continuity and operation delay time.  
**Check that new O-ring is installed properly.**

| VENT CONTROL/V Condition | Air passage continuity between (A) and (B) |
|--------------------------|--|
| ON                       | Not existed                                |
| OFF                      | Existed                                    |

**Operation takes less than 1 second.**

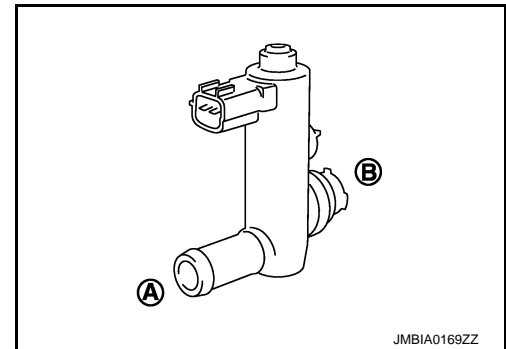

## ⊗ WITHOUT CONSULT

1. Clean the air passage [portion (A) to (B)] of EVAP canister vent control valve using an air blower.
2. Check air passage continuity and operation delay time under the following conditions.  
**Check that new O-ring is installed properly.**

| Condition  | Air passage continuity between (A) and (B) |
|--|--|
| 12 V direct current supply between terminals 1 and 2 | Not existed                                |
| OFF  | Existed                                    |

**Operation takes less than 1 second.**

## Is the inspection result normal?

- YES >> INSPECTION END  
 NO >> Replace EVAP canister vent control valve Refer to [FL-13, "Exploded View"](#).

A  
EC  
C  
D  
E  
F  
G  
H  
I  
J  
K  
L  
M  
N  
O  
P

# P0448 EVAP CANISTER VENT CONTROL VALVE

< DTC/CIRCUIT DIAGNOSIS >

[VK56VD FOR USA AND CANADA]

## P0448 EVAP CANISTER VENT CONTROL VALVE

### DTC Logic

INFOID:000000007187589

### DTC DETECTION LOGIC

| DTC No. | Trouble diagnosis name<br>(Trouble diagnosis content)          | DTC detecting condition   | Possible cause   |
|---------|--|---|--|
| P0448   | VENT CONTROL VALVE<br>(EVAP canister vent control valve close) | EVAP canister vent control valve remains closed under specified driving conditions. | <ul style="list-style-type: none"><li>• EVAP canister vent control valve</li><li>• EVAP control system pressure sensor and the circuit</li><li>• Blocked rubber tube to EVAP canister vent control valve</li><li>• EVAP canister is saturated with water</li></ul> |

### DTC CONFIRMATION PROCEDURE

#### 1. PRECONDITIONING

If DTC Confirmation Procedure has been previously conducted, always perform the following procedure before conducting the next test.

1. Turn ignition switch OFF and wait at least 10 seconds.
2. Turn ignition switch ON.
3. Turn ignition switch OFF and wait at least 10 seconds.

>> GO TO 2.

#### 2. PERFORM DTC CONFIRMATION PROCEDURE

1. Turn ignition switch ON and wait at least 5 seconds.
2. Turn ignition switch OFF and wait at least 10 seconds.
3. Start engine and let it idle for at least 1 minute.
4. Repeat next procedures 3 times.
  - Increase the engine speed up to between 3,000 and 3,500 rpm and maintain that speed for 2 minutes and 50 seconds to 3 minutes.
- Do not exceed 3 minutes.**
  - Fully released accelerator pedal and keep engine idle for approximately 5 seconds.
5. Repeat next procedure 20 times.
  - Quickly increase the engine speed up to between 4,000 and 4,500 rpm and maintain that speed for 25 to 30 seconds.
  - Fully released accelerator pedal and keep engine idle for at least 35 seconds.

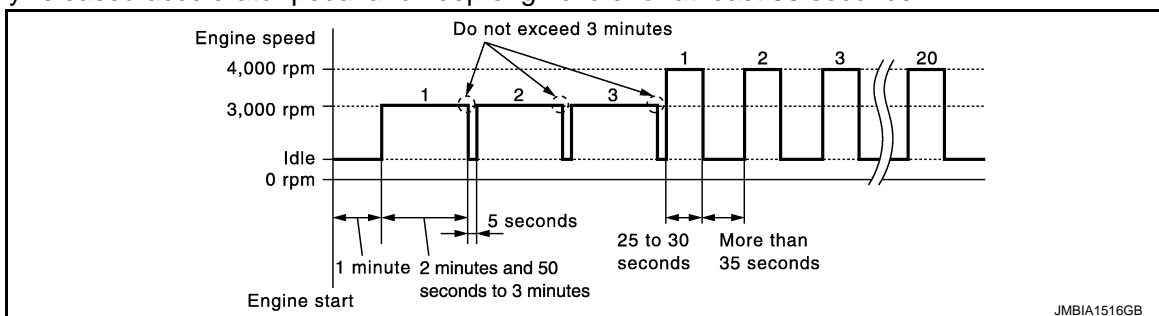

6. Check 1st trip DTC.

Is 1st trip DTC detected?

- YES >> Proceed to [EC-1336, "Diagnosis Procedure"](#).
- NO >> INSPECTION END

### Diagnosis Procedure

INFOID:000000007187590

#### 1. CHECK RUBBER TUBE

1. Turn ignition switch OFF.
2. Disconnect rubber tube connected to EVAP canister vent control valve.



# P0448 EVAP CANISTER VENT CONTROL VALVE

[VK56VD FOR USA AND CANADA]

< DTC/CIRCUIT DIAGNOSIS >

3. Check the rubber tube for clogging.

Is the inspection result normal?

YES >> GO TO 2.

NO >> Clean rubber tube using an air blower.

## 2.CHECK EVAP CANISTER VENT CONTROL VALVE

Refer to [EC-1334, "Component Inspection \(EVAP Canister Vent Control Valve\)"](#).

Is the inspection result normal?

YES >> GO TO 3.

NO >> Replace EVAP canister vent control valve. Refer to [FL-13, "Exploded View"](#).

## 3.CHECK IF EVAP CANISTER IS SATURATED WITH WATER

1. Remove EVAP canister with EVAP canister vent control valve and EVAP control system pressure sensor attached. Refer to [FL-13, "Exploded View"](#).

2. Check if water will drain from the EVAP canister (1).

- EVAP canister vent control valve (2)

Does water drain from EVAP canister?

YES >> GO TO 4.

NO >> GO TO 6.

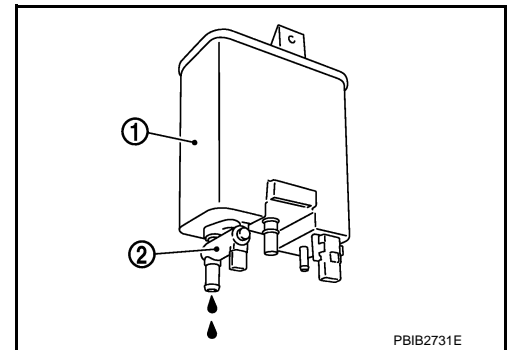

## 4.CHECK EVAP CANISTER

Weigh the EVAP canister with the EVAP canister vent control valve and EVAP control system pressure sensor attached.

**The weight should be less than 2.1 kg (4.6 lb).**

Is the inspection result normal?

YES >> GO TO 6.

NO >> GO TO 5.

## 5.DETECT MALFUNCTIONING PART

Check the following.

- EVAP canister for damage
- EVAP hose between EVAP canister and vehicle frame for clogging or poor connection

>> Repair hose or replace EVAP canister. Refer to [FL-15, "VK56VD : Hydraulic Layout"](#).

## 6.CHECK EVAP CONTROL SYSTEM PRESSURE SENSOR CONNECTOR

1. Disconnect EVAP control system pressure sensor harness connector.

2. Check that water is not inside connectors.

Is the inspection result normal?

YES >> GO TO 7.

NO >> Replace EVAP control system pressure sensor. Refer to [FL-13, "Exploded View"](#).

## 7.CHECK EVAP CONTROL SYSTEM PRESSURE SENSOR

Refer to [EC-1343, "Component Inspection \(EVAP Control System Pressure Sensor\)"](#).

Is the inspection result normal?

YES >> GO TO 8.

NO >> Replace EVAP control system pressure sensor. Refer to [FL-13, "Exploded View"](#).

## 8.CHECK INTERMITTENT INCIDENT

Refer to [GI-44, "Intermittent Incident"](#).

# P0448 EVAP CANISTER VENT CONTROL VALVE

< DTC/CIRCUIT DIAGNOSIS >

[VK56VD FOR USA AND CANADA]

>> INSPECTION END

## Component Inspection (EVAP Canister Vent Control Valve)

INFOID:000000007187591

### 1. CHECK EVAP CANISTER VENT CONTROL VALVE-I

1. Turn ignition switch OFF.
2. Remove EVAP canister vent control valve from EVAP canister. Refer to [FL-13, "Exploded View"](#).
3. Check portion (A) of EVAP canister vent control valve for rust.

Is it rusted?

- YES >> Replace EVAP canister vent control valve. [FL-13, "Exploded View"](#).
- NO >> GO TO 2.

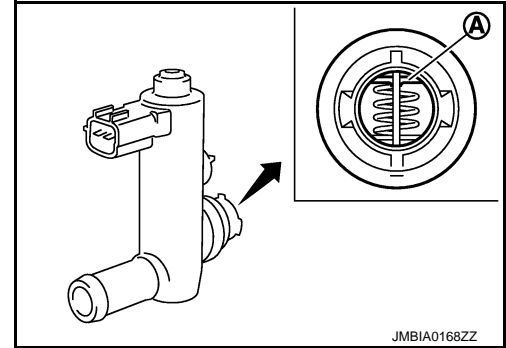

### 2. CHECK EVAP CANISTER VENT CONTROL VALVE-II

Ⓟ WITH CONSULT

1. Reconnect harness connectors disconnected.
2. Turn ignition switch ON.
3. Perform "VENT CONTROL/V" in "ACTIVE TEST" mode.
4. Check air passage continuity and operation delay time.  
**Check that new O-ring is installed properly.**

| VENT CONTROL/V Condition | Air passage continuity between (A) and (B) |
|--------------------------|--|
| ON                       | Not existed                                |
| OFF                      | Existed                                    |

Operation takes less than 1 second.

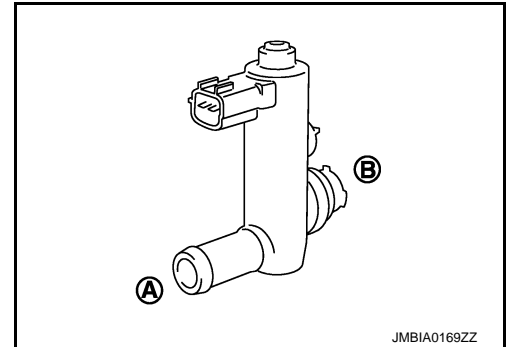

ⓧ WITHOUT CONSULT

1. Disconnect EVAP canister vent control valve harness connector.
2. Check air passage continuity and operation delay time under the following conditions.  
**Check that new O-ring is installed properly.**

| Condition  | Air passage continuity between (A) and (B) |
|--|--|
| 12 V direct current supply between terminals 1 and 2 | Not existed                                |
| OFF  | Existed                                    |

Operation takes less than 1 second.

Is the inspection result normal?

- YES >> GO TO 3.
- NO >> Replace EVAP canister vent control valve. Refer to [FL-13, "Exploded View"](#).

### 3. CHECK EVAP CANISTER VENT CONTROL VALVE-III

Ⓟ WITH CONSULT

1. Clean the air passage [portion (A) to (B)] of EVAP canister vent control valve using an air blower.
2. Perform "VENT CONTROL/V" in "ACTIVE TEST" mode.

# P0448 EVAP CANISTER VENT CONTROL VALVE

[VK56VD FOR USA AND CANADA]

< DTC/CIRCUIT DIAGNOSIS >

3. Check air passage continuity and operation delay time.  
**Check that new O-ring is installed properly.**

| VENT CONTROL/V Condition | Air passage continuity between (A) and (B) |
|--------------------------|--|
| ON                       | Not existed                                |
| OFF                      | Existed                                    |

**Operation takes less than 1 second.**

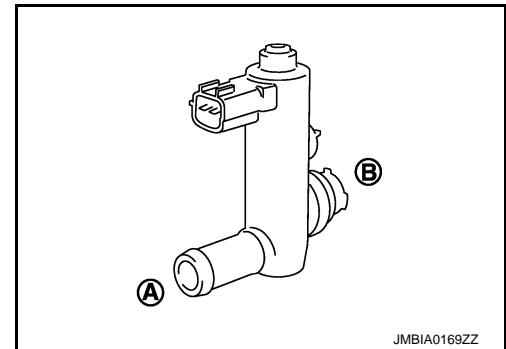

## ⊗ WITHOUT CONSULT

1. Clean the air passage [portion (A) to (B)] of EVAP canister vent control valve using an air blower.
2. Check air passage continuity and operation delay time under the following conditions.  
**Check that new O-ring is installed properly.**

| Condition  | Air passage continuity between (A) and (B) |
|--|--|
| 12 V direct current supply between terminals 1 and 2 | Not existed                                |
| OFF  | Existed                                    |

**Operation takes less than 1 second.**

Is the inspection result normal?

YES >> INSPECTION END

NO >> Replace EVAP canister vent control valve Refer to [FL-13, "Exploded View"](#).

A  
EC  
C  
D  
E  
F  
G  
H  
I  
J  
K  
L  
M  
N  
O  
P

# P0451 EVAP CONTROL SYSTEM PRESSURE SENSOR

< DTC/CIRCUIT DIAGNOSIS >

[VK56VD FOR USA AND CANADA]

## P0451 EVAP CONTROL SYSTEM PRESSURE SENSOR

### DTC Logic

INFOID:000000007187592

### DTC DETECTION LOGIC

| DTC No. | Trouble diagnosis name<br>(Trouble diagnosis content)                  | DTC detecting condition  | Possible cause  |
|---------|--|--|---|
| P0451   | EVAP SYS PRES SEN<br>(EVAP control system pressure sensor performance) | ECM detects a sloshing signal from the EVAP control system pressure sensor | <ul style="list-style-type: none"><li>• Harness or connectors<br/>(EVAP control system pressure sensor circuit is shorted.)<br/>(Crankshaft position sensor circuit is open or shorted.)<br/>[Camshaft position sensor (bank 1) circuit is shorted.]<br/>(Accelerator pedal position sensor 2 circuit is shorted.)<br/>(Battery current sensor circuit is shorted.)<br/>(Refrigerant pressure sensor circuit is shorted.)</li><li>• EVAP control system pressure sensor</li><li>• Crankshaft position sensor</li><li>• Camshaft position sensor (bank 1)</li><li>• Accelerator pedal position sensor 2</li><li>• Battery current sensor</li><li>• Refrigerant pressure sensor</li></ul> |

### DTC CONFIRMATION PROCEDURE

#### NOTE:

**Never remove fuel filler cap during DTC confirmation procedure.**

#### 1. PRECONDITIONING

If DTC Confirmation Procedure has been previously conducted, always perform the following procedure before conducting the next test.

1. Turn ignition switch OFF and wait at least 10 seconds.
2. Turn ignition switch ON.
3. Turn ignition switch OFF and wait at least 10 seconds.

With CONSULT>>GO TO 2.

Without CONSULT>>GO TO 5.

#### 2. PERFORM DTC CONFIRMATION PROCEDURE-1

Ⓜ With CONSULT

1. Start engine and let it idle for least 40 seconds.

#### NOTE:

**Do not depress accelerator pedal even slightly.**

2. Check 1st trip DTC.

Is 1st trip DTC detected?

YES >> Proceed to [EC-1341, "Diagnosis Procedure"](#).

NO >> GO TO 3.

#### 3. PERFORM DTC CONFIRMATION PROCEDURE-2

Ⓜ With CONSULT

1. Select "EVAP DIAG READY" in "DATA MONITOR" mode of "ENGINE".
2. Let it idle until "OFF" of "EVAP DIAG READY" changes to "ON".

#### NOTE:

**It will take at most 2 hours until "OFF" of "EVAP DIAG READY" changes to "ON".**

3. Turn ignition switch OFF and wait at least 90 minutes.

#### NOTE:

**Never turn ignition switch ON during 90 minutes.**

4. Turn ignition switch ON.
5. Select "EVAP LEAK DIAG" in "DATA MONITOR" mode of "ENGINE".
6. Check that "EVAP LEAK DIAG" indication.

Which is displayed on CONSULT?

# P0451 EVAP CONTROL SYSTEM PRESSURE SENSOR

[VK56VD FOR USA AND CANADA]

## < DTC/CIRCUIT DIAGNOSIS >

CMPLT >> GO TO 4.

- YET >> 1. Perform DTC CONFIRMATION PROCEDURE again.  
2. GO TO 1.

### 4.PERFORM DTC CONFIRMATION PROCEDURE-3

 With CONSULT  
Check 1st trip DTC.

Is 1st trip DTC detected?

- YES >> Proceed to [EC-1341, "Diagnosis Procedure"](#).  
NO >> INSPECTION END

### 5.PERFORM DTC CONFIRMATION PROCEDURE-4

 With GST

1. Start engine and let it idle for least 40 seconds.

**NOTE:**

**Do not depress accelerator pedal even slightly.**

2. Check 1st trip DTC.

Is 1st trip DTC detected?

- YES >> Proceed to [EC-1341, "Diagnosis Procedure"](#).  
NO >> GO TO 6.

### 6.PERFORM DTC CONFIRMATION PROCEDURE-5

 With GST

1. Let it idle for at least 2 hours.  
2. Turn ignition switch OFF and wait at least 90 minutes.

**NOTE:**

**Never turn ignition switch ON during 90 minutes.**

3. Turn ignition switch ON.  
4. Check 1st trip DTC.

Is 1st trip DTC detected?

- YES >> Proceed to [EC-1341, "Diagnosis Procedure"](#).  
NO >> INSPECTION END

## Diagnosis Procedure

INFOID:000000007187593

### 1.CHECK EVAP CONTROL SYSTEM PRESSURE SENSOR CONNECTOR

1. Disconnect EVAP control system pressure sensor harness connector.  
2. Check that water is not inside connectors.

Is the inspection result normal?

- YES >> GO TO 2.  
NO >> Repair or replace harness connector.

### 2.CHECK EVAP CONTROL SYSTEM PRESSURE SENSOR POWER SUPPLY CIRCUIT

1. Turn ignition switch ON.  
2. Check the voltage between EVAP control system pressure sensor harness connector and ground.

| EVAP control system pressure sensor |          | Ground | Voltage (V) |
|-------------------------------------|----------|--------|-------------|
| Connector                           | Terminal |        |             |
| B73                                 | 3        | Ground | Approx. 5 V |

Is the inspection result normal?

- YES >> GO TO 7.  
NO >> GO TO 3.

### 3.CHECK SENSOR POWER SUPPLY CIRCUIT

Check harness for short to power and short to ground, between the following terminals.

# P0451 EVAP CONTROL SYSTEM PRESSURE SENSOR

< DTC/CIRCUIT DIAGNOSIS >

[VK56VD FOR USA AND CANADA]

| ECM       |          | Sensor                              |           |          |
|-----------|----------|-------------------------------------|-----------|----------|
| Connector | Terminal | Name                                | Connector | Terminal |
| F111      | 76       | CKP sensor                          | F2        | 1        |
|           | 77       | Camshaft position sensor (bank 1)   | F84       | 1        |
| M160      | 133      | Battery current sensor              | E21       | 1        |
|           | 133      | EVAP control system pressure sensor | B73       | 3        |
|           | 133      | Refrigerant pressure sensor         | E77       | 3        |
|           | 131      | APP sensor 2 (Without ICC)          | M9        | 6        |
|           | 131      | APP sensor 2 (With ICC)             | M153      | 3        |

Is the inspection result normal?

YES >> GO TO 4.

NO >> Repair short to ground or short to power in harness or connectors.

## 4. CHECK COMPONENTS

Check the following.

- CKP sensor (Refer to [EC-1307, "Component Inspection \(Crankshaft Position Sensor\)"](#).)
- Camshaft position sensor (bank 1) (Refer to [EC-1312, "Component Inspection \(Camshaft Position Sensor\)"](#).)
- Battery current sensor (Refer to [EC-1438, "Component Inspection \(Battery Current Sensor\)"](#).)
- EVAP control system pressure sensor (Refer to [EC-1343, "Component Inspection \(EVAP Control System Pressure Sensor\)"](#).)
- Refrigerant pressure sensor (Refer to [EC-1539, "Diagnosis Procedure"](#).)

Is the inspection result normal?

YES >> GO TO 5.

NO >> Replace malfunctioning component.

## 5. CHECK APP SENSOR

Refer to [EC-1489, "Component Inspection \(Accelerator Pedal Position Sensor\)"](#).

Is the inspection result normal?

YES >> GO TO 8.

NO >> GO TO 6.

## 6. REPLACE ACCELERATOR PEDAL ASSEMBLY

Replace accelerator pedal assembly.

Refer to [ACC-3, "MODELS WITHOUT DISTANCE CONTROL ASSIST SYSTEM : Removal and Installation"](#) (Without distance control assist system)

Refer to [ACC-4, "MODELS WITH DISTANCE CONTROL ASSIST SYSTEM : Removal and Installation"](#) (With distance control assist system).

>> INSPECTION END

## 7. CHECK EVAP CONTROL SYSTEM PRESSURE SENSOR

Refer to [EC-1343, "Component Inspection \(EVAP Control System Pressure Sensor\)"](#).

Is the inspection result normal?

YES >> GO TO 8.

NO >> Replace EVAP control system pressure sensor. Refer to [FL-13, "Exploded View"](#).

## 8. CHECK INTERMITTENT INCIDENT

Refer to [GI-44, "Intermittent Incident"](#).

>> INSPECTION END

# P0451 EVAP CONTROL SYSTEM PRESSURE SENSOR

< DTC/CIRCUIT DIAGNOSIS >

[VK56VD FOR USA AND CANADA]

## Component Inspection (EVAP Control System Pressure Sensor)

INFOID:000000007187594

### 1. CHECK EVAP CONTROL SYSTEM PRESSURE SENSOR

1. Turn ignition switch OFF.
2. Remove EVAP control system pressure sensor with its harness connector. Refer to [FL-13. "Exploded View"](#).  
**Always replace O-ring with a new one.**
3. Install a vacuum pump to EVAP control system pressure sensor.
4. Turn ignition switch ON and check output voltage between ECM harness connector terminals under the following conditions.

| ECM       |          |          | Condition<br>[Applied vacuum kPa (kg/cm <sup>2</sup> , psi)] | Voltage (V)                       |
|-----------|----------|----------|--|-----------------------------------|
| Connector | +        | -        |  |                                   |
|           | Terminal | Terminal |  |                                   |
| M160      | 143      | 175      | Not applied  | 1.8 - 4.8                         |
|           |          |          | -26.7 (-0.272, -3.87)  | 2.1 to 2.5 lower than above value |

#### CAUTION:

- Always calibrate the vacuum pump gauge when using it.
- Never apply below -93.3 kPa (-0.952 kg/cm<sup>2</sup>, -13.53 psi) or pressure over 101.3 kPa (1.033 kg/cm<sup>2</sup>, 14.69 psi).

Is the inspection result normal?

YES >> INSPECTION END

NO >> Replace EVAP control system pressure sensor. Refer to [FL-13. "Exploded View"](#).

# P0452 EVAP CONTROL SYSTEM PRESSURE SENSOR

< DTC/CIRCUIT DIAGNOSIS >

[VK56VD FOR USA AND CANADA]

## P0452 EVAP CONTROL SYSTEM PRESSURE SENSOR

### DTC Logic

INFOID:000000007187595

### DTC DETECTION LOGIC

| DTC No. | Trouble diagnosis name<br>(Trouble diagnosis content)                | DTC detecting condition                                    | Possible cause  |
|---------|--|--|---|
| P0452   | EVAP SYS PRES SEN<br>(EVAP control system pressure sensor low input) | An excessively low voltage from the sensor is sent to ECM. | <ul style="list-style-type: none"> <li>• Harness or connectors<br/>(EVAP control system pressure sensor circuit is shorted.)<br/>(Crankshaft position sensor circuit is open or shorted.)<br/>[Camshaft position sensor (bank 1) circuit is shorted.]<br/>(Accelerator pedal position sensor 2 circuit is shorted.)<br/>(Battery current sensor circuit is shorted.)<br/>(Refrigerant pressure sensor circuit is shorted.)</li> <li>• EVAP control system pressure sensor</li> <li>• Crankshaft position sensor</li> <li>• Camshaft position sensor (bank 1)</li> <li>• Accelerator pedal position sensor 2</li> <li>• Battery current sensor</li> <li>• Refrigerant pressure sensor</li> </ul> |

### DTC CONFIRMATION PROCEDURE

#### 1. PRECONDITIONING

If DTC Confirmation Procedure has been previously conducted, always perform the following procedure before conducting the next test.

1. Turn ignition switch OFF and wait at least 10 seconds.
2. Turn ignition switch ON.
3. Turn ignition switch OFF and wait at least 10 seconds.

#### TESTING CONDITION:

**Always perform test at a temperature of 5°C (41°F) or more.**

>> GO TO 2.

#### 2. PERFORM DTC CONFIRMATION PROCEDURE

##### Ⓜ WITH CONSULT

1. Start engine and warm it up to normal operating temperature.
2. Turn ignition switch OFF and wait at least 10 seconds.
3. Turn ignition switch ON.
4. Turn ignition switch OFF and wait at least 10 seconds.
5. Turn ignition switch ON.
6. Select "DATA MONITOR" mode with CONSULT.
7. Check that "FUEL T/TMP SE" is more than 0°C (32°F).
8. Start engine and wait at least 20 seconds.
9. Check 1st trip DTC.

##### Ⓜ WITH GST

1. Start engine and warm it up to normal operating temperature.
2. Set voltmeter probes to ECM harness connector terminals under the following conditions.

| ECM       |  |          |
|-----------|--|----------|
| Connector | +  | -        |
|           | Terminal                                     | Terminal |
| M160      | 134<br>(Fuel tank temperature sensor signal) | 175      |

3. Check that the voltage is less than 4.2 V.
4. Turn ignition switch OFF and wait at least 10 seconds.
5. Turn ignition switch ON.



# P0452 EVAP CONTROL SYSTEM PRESSURE SENSOR

[VK56VD FOR USA AND CANADA]

## < DTC/CIRCUIT DIAGNOSIS >

6. Turn ignition switch OFF and wait at least 10 seconds.
7. Start engine and wait at least 20 seconds.
8. Check 1st trip DTC.

### Is 1st trip DTC detected?

- YES >> Proceed to [EC-1345, "Diagnosis Procedure"](#).  
NO >> INSPECTION END

## Diagnosis Procedure

INFOID:000000007187596

### 1. CHECK EVAP CONTROL SYSTEM PRESSURE SENSOR CONNECTOR

1. Disconnect EVAP control system pressure sensor harness connector.
2. Check that water is not inside connectors.

#### Is the inspection result normal?

- YES >> GO TO 2.  
NO >> Repair or replace harness connector.

### 2. CHECK EVAP CONTROL SYSTEM PRESSURE SENSOR POWER SUPPLY CIRCUIT-I

1. Turn ignition switch ON.
2. Check the voltage between EVAP control system pressure sensor harness connector and ground.

| EVAP control system pressure sensor |          | Ground | Voltage (V) |
|-------------------------------------|----------|--------|-------------|
| Connector                           | Terminal |        |             |
| B73                                 | 3        | Ground | Approx. 5   |

#### Is the inspection result normal?

- YES >> GO TO 9.  
NO >> GO TO 3.

### 3. CHECK EVAP CONTROL SYSTEM PRESSURE SENSOR POWER SUPPLY CIRCUIT-II

1. Turn ignition switch OFF.
2. Disconnect ECM harness connector.
3. Check the continuity between EVAP control system pressure sensor harness connector and ECM harness connector.

| EVAP control system pressure sensor |          | ECM       |          | Continuity |
|-------------------------------------|----------|-----------|----------|------------|
| Connector                           | Terminal | Connector | Terminal |            |
| B73                                 | 3        | M160      | 133      | Existed    |

#### Is the inspection result normal?

- YES >> GO TO 5.  
NO >> GO TO 4.

### 4. DETECT MALFUNCTIONING PART

Check the following.

- Harness for open between ECM and EVAP control system pressure sensor
- Loose or poor connection for each connector and harness

>> Repair open circuit.

### 5. CHECK SENSOR POWER SUPPLY CIRCUIT

Check harness for short to power and short to ground, between the following terminals.

# P0452 EVAP CONTROL SYSTEM PRESSURE SENSOR

< DTC/CIRCUIT DIAGNOSIS >

[VK56VD FOR USA AND CANADA]

| ECM       |          | Sensor                              |           |          |
|-----------|----------|-------------------------------------|-----------|----------|
| Connector | Terminal | Name                                | Connector | Terminal |
| F111      | 76       | CKP sensor                          | F2        | 1        |
|           | 77       | Camshaft position sensor (bank 1)   | F84       | 1        |
| M160      | 133      | Battery current sensor              | E21       | 1        |
|           | 133      | EVAP control system pressure sensor | B73       | 3        |
|           | 133      | Refrigerant pressure sensor         | E77       | 3        |
|           | 131      | APP sensor 2 (Without ICC)          | M9        | 6        |
|           | 131      | APP sensor 2 (With ICC)             | M153      | 3        |

Is the inspection result normal?

YES >> GO TO 6.

NO >> Repair short to ground or short to power in harness or connectors.

## 6. CHECK COMPONENTS

Check the following.

- CKP sensor (Refer to [EC-1307, "Component Inspection \(Crankshaft Position Sensor\)"](#).)
- Camshaft position sensor (bank 1) (Refer to [EC-1312, "Component Inspection \(Camshaft Position Sensor\)"](#).)
- Battery current sensor (Refer to [EC-1438, "Component Inspection \(Battery Current Sensor\)"](#).)
- EVAP control system pressure sensor (Refer to [EC-1343, "Component Inspection \(EVAP Control System Pressure Sensor\)"](#).)
- Refrigerant pressure sensor (Refer to [EC-1539, "Diagnosis Procedure"](#).)

Is the inspection result normal?

YES >> GO TO 7.

NO >> Replace malfunctioning component.

## 7. CHECK APP SENSOR

Refer to [EC-1489, "Component Inspection \(Accelerator Pedal Position Sensor\)"](#).

Is the inspection result normal?

YES >> GO TO 14.

NO >> GO TO 8.

## 8. REPLACE ACCELERATOR PEDAL ASSEMBLY

Replace accelerator pedal assembly.

Refer to [ACC-3, "MODELS WITHOUT DISTANCE CONTROL ASSIST SYSTEM : Removal and Installation"](#) (Without distance control assist system)

Refer to [ACC-4, "MODELS WITH DISTANCE CONTROL ASSIST SYSTEM : Removal and Installation"](#) (With distance control assist system).

>> INSPECTION END

## 9. CHECK EVAP CONTROL SYSTEM PRESSURE SENSOR GROUND CIRCUIT FOR OPEN AND SHORT

1. Turn ignition switch OFF.
2. Disconnect ECM harness connector.
3. Check the continuity between EVAP control system pressure sensor harness connector and ECM harness connector.

| EVAP control system pressure sensor |          | ECM       |          | Continuity |
|-------------------------------------|----------|-----------|----------|------------|
| Connector                           | Terminal | Connector | Terminal |            |
| B73                                 | 1        | M160      | 150      | Existed    |

4. Also check harness for short to ground and short to power.

Is the inspection result normal?

# P0452 EVAP CONTROL SYSTEM PRESSURE SENSOR

[VK56VD FOR USA AND CANADA]

< DTC/CIRCUIT DIAGNOSIS >

- YES >> GO TO 11.
- NO >> GO TO 10.

## 10. DETECT MALFUNCTIONING PART

Check the following.

- Harness for open or short between EVAP control system pressure sensor and ECM
- Loose or poor connection for each connector and harness

>> Repair open circuit, short to ground or short to power in harness or connectors.

## 11. CHECK EVAP CONTROL SYSTEM PRESSURE SENSOR INPUT SIGNAL CIRCUIT FOR OPEN AND SHORT

1. Check the continuity between EVAP control system pressure sensor harness connector and ECM harness connector.

| EVAP control system pressure sensor |          | ECM       |          | Continuity |
|-------------------------------------|----------|-----------|----------|------------|
| Connector                           | Terminal | Connector | Terminal |            |
| B73                                 | 2        | M160      | 143      | Existed    |

2. Also check harness for short to ground and short to power.

Is the inspection result normal?

- YES >> GO TO 13.
- NO >> GO TO 12.

## 12. DETECT MALFUNCTIONING PART

Check the following.

- Harness for open or short between EVAP control system pressure sensor and ECM
- Loose or poor connection for each connector and harness

>> Repair open circuit, short to ground or short to power in harness or connectors.

## 13. CHECK EVAP CONTROL SYSTEM PRESSURE SENSOR

Refer to [EC-1347, "Component Inspection \(EVAP Control System Pressure Sensor\)"](#).

Is the inspection result normal?

- YES >> GO TO 14.
- NO >> Replace EVAP control system pressure sensor. Refer to [FL-13, "Exploded View"](#).

## 14. CHECK INTERMITTENT INCIDENT

Refer to [GI-44, "Intermittent Incident"](#).

>> INSPECTION END

## Component Inspection (EVAP Control System Pressure Sensor)

INFOID:000000007187597

### 1. CHECK EVAP CONTROL SYSTEM PRESSURE SENSOR

1. Turn ignition switch OFF.
2. Remove EVAP control system pressure sensor with its harness connector. Refer to [FL-13, "Exploded View"](#).  
**Always replace O-ring with a new one.**
3. Install a vacuum pump to EVAP control system pressure sensor.
4. Turn ignition switch ON and check output voltage between ECM harness connector terminals under the following conditions.

# P0452 EVAP CONTROL SYSTEM PRESSURE SENSOR

< DTC/CIRCUIT DIAGNOSIS >

[VK56VD FOR USA AND CANADA]

| ECM       |          |          | Condition<br>[Applied vacuum kPa (kg/cm <sup>2</sup> , psi)] | Voltage (V)                       |
|-----------|----------|----------|--|-----------------------------------|
| Connector | +        | -        |  |                                   |
|           | Terminal | Terminal |  |                                   |
| M160      | 143      | 175      | Not applied  | 1.8 - 4.8                         |
|           |          |          | -26.7 (-0.272, -3.87)  | 2.1 to 2.5 lower than above value |

**CAUTION:**

- Always calibrate the vacuum pump gauge when using it.
- Never apply below -93.3 kPa (-0.952 kg/cm<sup>2</sup>, -13.53 psi) or pressure over 101.3 kPa (1.033 kg/cm<sup>2</sup>, 14.69 psi).

Is the inspection result normal?

YES >> INSPECTION END

NO >> Replace EVAP control system pressure sensor. Refer to [FL-13, "Exploded View"](#).

# P0453 EVAP CONTROL SYSTEM PRESSURE SENSOR

< DTC/CIRCUIT DIAGNOSIS >

[VK56VD FOR USA AND CANADA]

## P0453 EVAP CONTROL SYSTEM PRESSURE SENSOR

### DTC Logic

INFOID:000000007187598

### DTC DETECTION LOGIC

| DTC No. | Trouble diagnosis name<br>(Trouble diagnosis content)                 | DTC detecting condition                                     | Possible cause   |
|---------|---|---|--|
| P0453   | EVAP SYS PRES SEN<br>(EVAP control system pressure sensor high input) | An excessively high voltage from the sensor is sent to ECM. | <ul style="list-style-type: none"> <li>• Harness or connectors<br/>(EVAP control system pressure sensor circuit is shorted.)<br/>(Crankshaft position sensor circuit is open or shorted.)<br/>[Camshaft position sensor (bank 1) circuit is shorted.]<br/>(Accelerator pedal position sensor 2 circuit is shorted.)<br/>(Battery current sensor circuit is shorted.)<br/>(Refrigerant pressure sensor circuit is shorted.)</li> <li>• EVAP control system pressure sensor</li> <li>• Crankshaft position sensor</li> <li>• Camshaft position sensor (bank 1)</li> <li>• Accelerator pedal position sensor 2</li> <li>• Battery current sensor</li> <li>• Refrigerant pressure sensor</li> <li>• EVAP canister vent control valve</li> <li>• EVAP canister</li> <li>• Rubber hose from EVAP canister vent control valve to vehicle frame</li> </ul> |

### DTC CONFIRMATION PROCEDURE

#### 1. PRECONDITIONING

If DTC Confirmation Procedure has been previously conducted, always perform the following procedure before conducting the next test.

1. Turn ignition switch OFF and wait at least 10 seconds.
2. Turn ignition switch ON.
3. Turn ignition switch OFF and wait at least 10 seconds.

#### TESTING CONDITION:

**Always perform test at a temperature of 5°C (41°F) or more.**

>> GO TO 2.

#### 2. PERFORM DTC CONFIRMATION PROCEDURE

##### Ⓜ WITH CONSULT

1. Start engine and warm it up to normal operating temperature.
2. Turn ignition switch OFF and wait at least 10 seconds.
3. Turn ignition switch ON.
4. Turn ignition switch OFF and wait at least 10 seconds.
5. Turn ignition switch ON.
6. Select "DATA MONITOR" mode with CONSULT.
7. Check that "FUEL T/TMP SE" is more than 0°C (32°F).
8. Start engine and wait at least 20 seconds.
9. Check 1st trip DTC.

##### Ⓜ WITH GST

1. Start engine and warm it up to normal operating temperature.
2. Set voltmeter probes to ECM harness connector terminals under the following conditions.

# P0453 EVAP CONTROL SYSTEM PRESSURE SENSOR

< DTC/CIRCUIT DIAGNOSIS >

[VK56VD FOR USA AND CANADA]

| ECM       |  | Ground   |
|-----------|--|----------|
| Connector | +  | -        |
|           | Terminal                                     | Terminal |
| M160      | 134<br>(Fuel tank temperature sensor signal) | 175      |

3. Check that the voltage is less than 4.2 V.
4. Turn ignition switch OFF and wait at least 10 seconds.
5. Turn ignition switch ON.
6. Turn ignition switch OFF and wait at least 10 seconds.
7. Start engine and wait at least 20 seconds.
8. Check 1st trip DTC.

Is 1st trip DTC detected?

- YES >> Proceed to [EC-1350, "Diagnosis Procedure"](#).  
NO >> INSPECTION END

## Diagnosis Procedure

INFOID:000000007187599

### 1.CHECK EVAP CONTROL SYSTEM PRESSURE SENSOR CONNECTOR

1. Disconnect EVAP control system pressure sensor harness connector.
2. Check that water is not inside connectors.

Is the inspection result normal?

- YES >> GO TO 2.  
NO >> Repair or replace harness connector.

### 2.CHECK EVAP CONTROL SYSTEM PRESSURE SENSOR POWER SUPPLY CIRCUIT

1. Turn ignition switch ON.
2. Check the voltage between EVAP control system pressure sensor harness connector and ground.

| EVAP control system pressure sensor |          | Ground | Voltage (V) |
|-------------------------------------|----------|--------|-------------|
| Connector                           | Terminal |        |             |
| B73                                 | 3        | Ground | Approx. 5   |

Is the inspection result normal?

- YES >> GO TO 9.  
NO >> GO TO 3.

### 3.CHECK EVAP CONTROL SYSTEM PRESSURE SENSOR POWER SUPPLY CIRCUIT-II

1. Turn ignition switch OFF.
2. Disconnect ECM harness connector.
3. Check the continuity between EVAP control system pressure sensor harness connector and ECM harness connector.

| EVAP control system pressure sensor |          | ECM       |          | Continuity |
|-------------------------------------|----------|-----------|----------|------------|
| Connector                           | Terminal | Connector | Terminal |            |
| B73                                 | 3        | M160      | 133      | Existed    |

Is the inspection result normal?

- YES >> GO TO 5.  
NO >> GO TO 4.

### 4.DETECT MALFUNCTIONING PART

Check the following.

- Harness for open between ECM and EVAP control system pressure sensor
- Loose or poor connection for each connector and harness

# P0453 EVAP CONTROL SYSTEM PRESSURE SENSOR

< DTC/CIRCUIT DIAGNOSIS >

[VK56VD FOR USA AND CANADA]

>> Repair open circuit.

## 5. CHECK SENSOR POWER SUPPLY CIRCUIT

Check harness for short to power and short to ground, between the following terminals.

| ECM       |          | Sensor                              |           |          |
|-----------|----------|-------------------------------------|-----------|----------|
| Connector | Terminal | Name                                | Connector | Terminal |
| F111      | 76       | CKP sensor                          | F2        | 1        |
|           | 77       | Camshaft position sensor (bank 1)   | F84       | 1        |
| M160      | 133      | Battery current sensor              | E21       | 1        |
|           | 133      | EVAP control system pressure sensor | B73       | 3        |
|           | 133      | Refrigerant pressure sensor         | E77       | 3        |
|           | 131      | APP sensor 2 (Without ICC)          | M9        | 6        |
|           | 131      | APP sensor 2 (With ICC)             | M153      | 3        |

Is the inspection result normal?

YES >> GO TO 6.

NO >> Repair short to ground or short to power in harness or connectors.

## 6. CHECK COMPONENTS

Check the following.

- CKP sensor (Refer to [EC-1307, "Component Inspection \(Crankshaft Position Sensor\)"](#).)
- Camshaft position sensor (bank 1) (Refer to [EC-1312, "Component Inspection \(Camshaft Position Sensor\)"](#).)
- Battery current sensor (Refer to [EC-1438, "Component Inspection \(Battery Current Sensor\)"](#).)
- EVAP control system pressure sensor (Refer to [EC-1343, "Component Inspection \(EVAP Control System Pressure Sensor\)"](#).)
- Refrigerant pressure sensor (Refer to [EC-1539, "Diagnosis Procedure"](#).)

Is the inspection result normal?

YES >> GO TO 7.

NO >> Replace malfunctioning component.

## 7. CHECK APP SENSOR

Refer to [EC-1489, "Component Inspection \(Accelerator Pedal Position Sensor\)"](#).

Is the inspection result normal?

YES >> GO TO 19.

NO >> GO TO 8.

## 8. REPLACE ACCELERATOR PEDAL ASSEMBLY

Replace accelerator pedal assembly.

Refer to [ACC-3, "MODELS WITHOUT DISTANCE CONTROL ASSIST SYSTEM : Removal and Installation"](#) (Without distance control assist system)

Refer to [ACC-4, "MODELS WITH DISTANCE CONTROL ASSIST SYSTEM : Removal and Installation"](#) (With distance control assist system).

>> INSPECTION END

## 9. CHECK EVAP CONTROL SYSTEM PRESSURE SENSOR GROUND CIRCUIT FOR OPEN AND SHORT

1. Turn ignition switch OFF.
2. Disconnect ECM harness connector.
3. Check the continuity between EVAP control system pressure sensor harness connector and ECM harness connector.

# P0453 EVAP CONTROL SYSTEM PRESSURE SENSOR

< DTC/CIRCUIT DIAGNOSIS >

[VK56VD FOR USA AND CANADA]

| EVAP control system pressure sensor |          | ECM       |          | Continuity |
|-------------------------------------|----------|-----------|----------|------------|
| Connector                           | Terminal | Connector | Terminal |            |
| B73                                 | 1        | M160      | 150      | Existed    |

4. Also check harness for short to ground and short to power.

Is the inspection result normal?

YES >> GO TO 11.

NO >> GO TO 10.

## 10.DETECT MALFUNCTIONING PART

Check the following.

- Harness for open or short between EVAP control system pressure sensor and ECM
- Loose or poor connection for each connector and harness

>> Repair open circuit, short to ground or short to power in harness or connectors.

## 11.CHECK EVAP CONTROL SYSTEM PRESSURE SENSOR INPUT SIGNAL CIRCUIT FOR OPEN AND SHORT

1. Check the continuity between EVAP control system pressure sensor harness connector and ECM harness connector.

| EVAP control system pressure sensor |          | ECM       |          | Continuity |
|-------------------------------------|----------|-----------|----------|------------|
| Connector                           | Terminal | Connector | Terminal |            |
| B73                                 | 2        | M160      | 143      | Existed    |

2. Also check harness for short to ground and short to power.

Is the inspection result normal?

YES >> GO TO 13.

NO >> GO TO 12.

## 12.DETECT MALFUNCTIONING PART

Check the following.

- Harness for open or short between EVAP control system pressure sensor and ECM
- Loose or poor connection for each connector and harness

>> Repair open circuit, short to ground or short to power in harness or connectors.

## 13.CHECK RUBBER TUBE

1. Disconnect rubber tube connected to EVAP canister vent control valve. Refer to [FL-15, "VK56VD : Hydraulic Layout"](#).

2. Check the rubber tube for clogging.

Is the inspection result normal?

YES >> GO TO 14.

NO >> Clean the rubber tube using an air blower, repair or replace rubber tube.

## 14.CHECK EVAP CANISTER VENT CONTROL VALVE

Refer to [EC-1334, "Component Inspection \(EVAP Canister Vent Control Valve\)"](#).

Is the inspection result normal?

YES >> GO TO 15.

NO >> Replace EVAP canister vent control valve. Refer to [FL-13, "Exploded View"](#).

## 15.CHECK EVAP CONTROL SYSTEM PRESSURE SENSOR

Refer to [EC-1353, "Component Inspection \(EVAP Control System Pressure Sensor\)"](#).

Is the inspection result normal?



# P0453 EVAP CONTROL SYSTEM PRESSURE SENSOR

[VK56VD FOR USA AND CANADA]

## < DTC/CIRCUIT DIAGNOSIS >

YES >> GO TO 16.

NO >> Replace EVAP control system pressure sensor. Refer to [FL-13, "Exploded View"](#).

### 16. CHECK IF EVAP CANISTER IS SATURATED WITH WATER

- Remove EVAP canister with EVAP canister vent control valve and EVAP control system pressure sensor attached. Refer to [FL-13, "Exploded View"](#).
- Check if water will drain from the EVAP canister (1).
  - EVAP canister vent control valve (2)

Does water drain from EVAP canister?

YES >> GO TO 17.

NO >> GO TO 19.

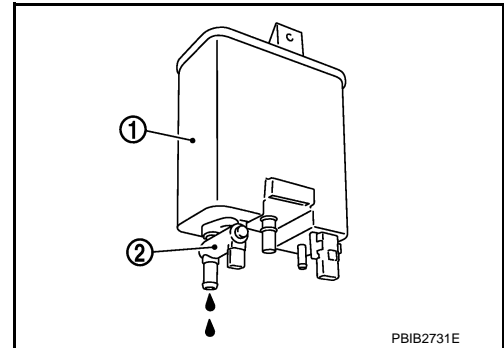

### 17. CHECK EVAP CANISTER

Weigh the EVAP canister with the EVAP canister vent control valve and EVAP control system pressure sensor attached.

**The weight should be less than 2.1 kg (4.6 lb).**

Is the inspection result normal?

YES >> GO TO 19.

NO >> GO TO 18.

### 18. DETECT MALFUNCTIONING PART

Check the following.

- EVAP canister for damage
- EVAP hose between EVAP canister and vehicle frame for clogging or poor connection

>> Repair hose or replace EVAP canister. Refer to [FL-15, "VK56VD : Hydraulic Layout"](#).

### 19. CHECK INTERMITTENT INCIDENT

Refer to [GI-44, "Intermittent Incident"](#).

>> INSPECTION END

## Component Inspection (EVAP Control System Pressure Sensor)

INFOID:000000007187600

### 1. CHECK EVAP CONTROL SYSTEM PRESSURE SENSOR

- Turn ignition switch OFF.
- Remove EVAP control system pressure sensor with its harness connector. Refer to [FL-13, "Exploded View"](#).  
**Always replace O-ring with a new one.**
- Install a vacuum pump to EVAP control system pressure sensor.
- Turn ignition switch ON and check output voltage between ECM harness connector terminals under the following conditions.

| Connector | ECM      |          | Condition<br>[Applied vacuum kPa (kg/cm <sup>2</sup> , psi)] | Voltage (V)                       |
|-----------|----------|----------|--|-----------------------------------|
|           | +        | -        |  |                                   |
|           | Terminal | Terminal |  |                                   |
| M160      | 143      | 175      | Not applied  | 1.8 - 4.8                         |
|           |          |          | -26.7 (-0.272, -3.87)  | 2.1 to 2.5 lower than above value |

**CAUTION:**

- Always calibrate the vacuum pump gauge when using it.

## P0453 EVAP CONTROL SYSTEM PRESSURE SENSOR

< DTC/CIRCUIT DIAGNOSIS >

[VK56VD FOR USA AND CANADA]

- Never apply below -93.3 kPa (-0.952 kg/cm<sup>2</sup>, -13.53 psi) or pressure over 101.3 kPa (1.033 kg/cm<sup>2</sup>, 14.69 psi).

Is the inspection result normal?

YES >> INSPECTION END

NO >> Replace EVAP control system pressure sensor. Refer to [FL-13, "Exploded View"](#).

# P0456 EVAP CONTROL SYSTEM

< DTC/CIRCUIT DIAGNOSIS >

[VK56VD FOR USA AND CANADA]

## P0456 EVAP CONTROL SYSTEM

### DTC Logic

INFOID:000000007187601

### DTC DETECTION LOGIC

This diagnosis detects leaks in the EVAP line between fuel tank and EVAP canister purge volume control solenoid valve, using the negative pressure caused by decrease of fuel temperature in the fuel tank after turning ignition switch OFF.

If ECM judges there are no leaks, the diagnosis will be OK.

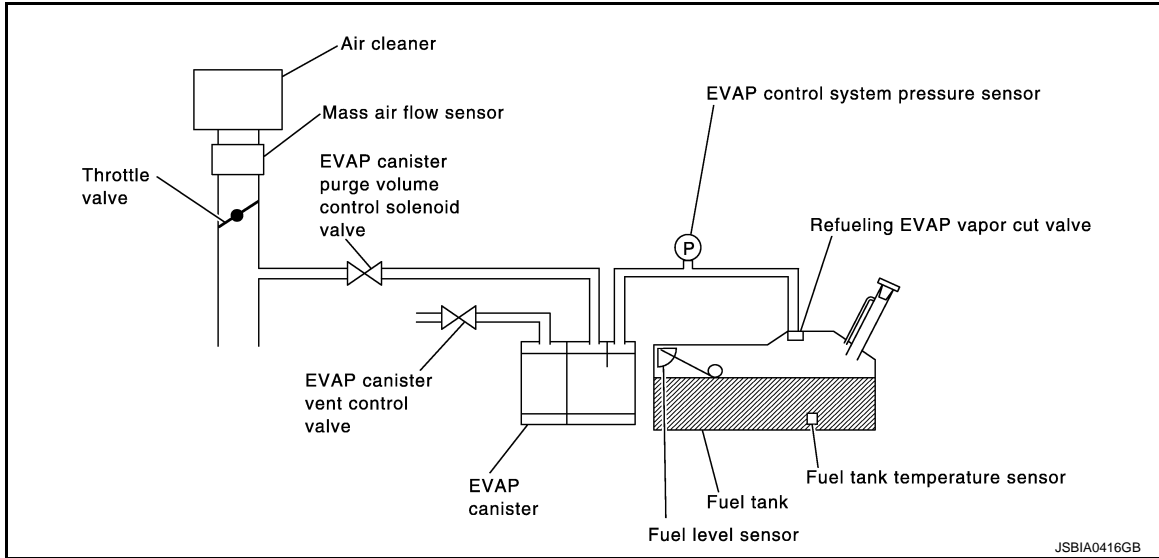

| DTC No. | Trouble diagnosis name<br>(Trouble diagnosis content) | DTC detecting condition   | Possible cause  |
|---------|---|---|---|
| P0456   | Evaporative emission control system leak              | <ul style="list-style-type: none"> <li>• EVAP system has a leak.</li> <li>• EVAP system does not operate properly.</li> </ul> | <ul style="list-style-type: none"> <li>• Incorrect fuel tank vacuum relief valve</li> <li>• Incorrect fuel filler cap used</li> <li>• Fuel filler cap remains open or does not close.</li> <li>• Foreign matter caught in fuel filler cap.</li> <li>• Leak is in line between intake manifold and EVAP canister purge volume control solenoid valve.</li> <li>• Foreign matter caught in EVAP canister vent control valve.</li> <li>• EVAP canister or fuel tank leaks</li> <li>• EVAP purge line (pipe and rubber tube) leaks</li> <li>• EVAP purge line rubber tube bent</li> <li>• Loose or disconnected rubber tube</li> <li>• EVAP canister vent control valve and the circuit</li> <li>• EVAP canister purge volume control solenoid valve and the circuit</li> <li>• Fuel tank temperature sensor</li> <li>• O-ring of EVAP canister vent control valve is missing or damaged</li> <li>• EVAP canister is saturated with water</li> <li>• EVAP control system pressure sensor</li> <li>• Refueling EVAP vapor cut valve</li> <li>• ORVR system leaks</li> <li>• Fuel level sensor and the circuit</li> <li>• Foreign matter caught in EVAP canister purge volume control solenoid valve</li> </ul> |

### CAUTION:

- Use only a genuine NISSAN fuel filler cap as a replacement. If an incorrect fuel filler cap is used, the MIL may illuminate.
- If the fuel filler cap is not tightened properly, the MIL may illuminate.
- Use only a genuine NISSAN rubber tube as a replacement.

### DTC CONFIRMATION PROCEDURE

# P0456 EVAP CONTROL SYSTEM

[VK56VD FOR USA AND CANADA]

< DTC/CIRCUIT DIAGNOSIS >

## 1. PRECONDITIONING

If DTC Confirmation Procedure has been previously conducted, always perform the following before conducting the next test.

1. Turn ignition switch OFF and wait at least 10 seconds.
2. Turn ignition switch ON.
3. Turn ignition switch OFF and wait at least 10 seconds.

Do you have CONSULT?

YES >> GO TO 2.

NO >> GO TO 4.

## 2. PERFORM DTC CONFIRMATION PROCEDURE-I

Ⓢ WITH CONSULT

1. Turn ignition switch ON and select "EVAP DIAG READY" in "DATA MONITOR" mode with CONSULT.
2. Start engine and wait at idle until "OFF" of "EVAP DIAG READY" changes to "ON".

**NOTE:**

**It will take at most 2 hours until "OFF" of "EVAP DIAG READY" changes to "ON".**

3. Turn ignition switch OFF and wait at least 90 minutes.

**NOTE:**

**Never turn ignition switch ON during 90 minutes.**

4. Turn ignition switch ON and select "EVAP LEAK DIAG" in "DATA MONITOR" mode with CONSULT.
5. Check that "EVAP LEAK DIAG" indication.

Which is displayed on CONSULT?

CMPLT >> GO TO 3.

YET >> Perform DTC CONFIRMATION PROCEDURE again. GO TO 1.

## 3. PERFORM DTC CONFIRMATION PROCEDURE-II

Check 1st trip DTC.

Is 1st trip DTC detected?

YES >> Proceed to [EC-1356, "Diagnosis Procedure"](#).

NO >> INSPECTION END.

## 4. PERFORM DTC CONFIRMATION PROCEDURE

Ⓢ WITH GST

1. Start engine and wait engine idle for at least 2 hours.
2. Turn ignition switch OFF and wait at least 90 minutes.

**NOTE:**

**Never turn ignition switch ON during 90 minutes.**

3. Turn ignition switch ON.
4. Check 1st trip DTC.

Is 1st trip DTC detected?

YES >> Proceed to [EC-1356, "Diagnosis Procedure"](#).

NO >> INSPECTION END.

## Diagnosis Procedure

INFOID:000000007187602

### 1. CHECK FUEL FILLER CAP DESIGN

1. Turn ignition switch OFF.

## P0456 EVAP CONTROL SYSTEM

[VK56VD FOR USA AND CANADA]

< DTC/CIRCUIT DIAGNOSIS >

2. Check for genuine NISSAN fuel filler cap design.

Is the inspection result normal?

YES >> GO TO 2.

NO >> Replace with genuine NISSAN fuel filler cap. Refer to [FL-10, "Exploded View"](#).

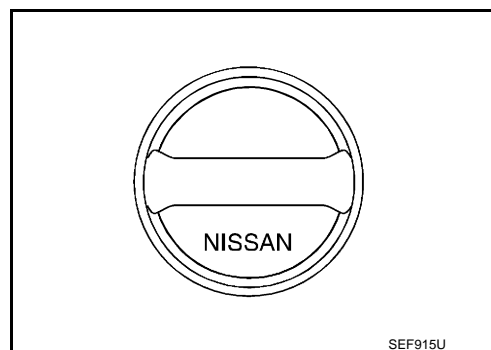

### 2.CHECK FUEL FILLER CAP INSTALLATION

Check that the cap is tightened properly by rotating the cap clockwise.

Is the inspection result normal?

YES >> GO TO 3.

NO >> Open fuel filler cap, then clean cap and fuel filler neck threads using air blower. Then retighten until reteaching sound is heard.

### 3.CHECK FUEL FILLER CAP FUNCTION

Check for air releasing sound while opening the fuel filler cap.

Is the inspection result normal?

YES >> GO TO 5.

NO >> GO TO 4.

### 4.CHECK FUEL TANK VACUUM RELIEF VALVE

Refer to [EC-1360, "Component Inspection \(Fuel Filler Cap\)"](#).

Is the inspection result normal?

YES >> GO TO 5.

NO >> Replace fuel filler cap with a genuine one. Refer to [FL-10, "Exploded View"](#).

### 5.CHECK FOR EVAP LEAK

Refer to [FL-16, "Inspection"](#).

Is there any leak in EVAP line?

YES >> Repair or replace.

NO >> GO TO 6.

### 6.CHECK EVAP CANISTER VENT CONTROL VALVE

Check the following.

- EVAP canister vent control valve is installed properly.

Refer to [FL-13, "Exploded View"](#).

- EVAP canister vent control valve.

Refer to [EC-1338, "Component Inspection \(EVAP Canister Vent Control Valve\)"](#).

Is the inspection result normal?

YES >> GO TO 7.

NO >> Repair or replace EVAP canister vent control valve and O-ring. Refer to [FL-13, "Exploded View"](#).

### 7.CHECK IF EVAP CANISTER SATURATED WITH WATER

## P0456 EVAP CONTROL SYSTEM

[VK56VD FOR USA AND CANADA]

### < DTC/CIRCUIT DIAGNOSIS >

1. Remove EVAP canister (1) with EVAP canister vent control valve (2) and EVAP control system pressure sensor attached.
2. Check if water will drain from the EVAP canister.

#### Does water drain from EVAP canister?

- YES >> GO TO 8.  
NO-1 >> With CONSULT: GO TO 10.  
NO-2 >> Without CONSULT: GO TO 11.

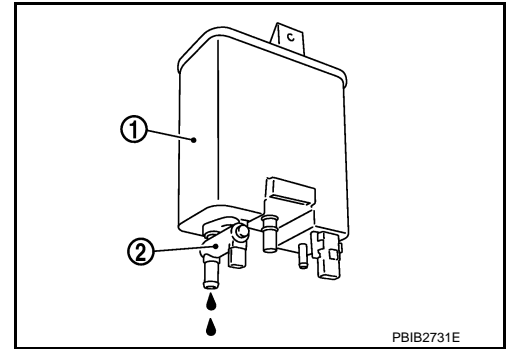

## 8. CHECK EVAP CANISTER

Weigh the EVAP canister assembly with the EVAP canister vent control valve and EVAP control system pressure sensor attached. Refer to [FL-13, "Exploded View"](#).

**The weight should be less than 2.1 kg (4.6 lb).**

#### Is the inspection result normal?

- YES-1 >> With CONSULT: GO TO 10.  
YES-2 >> Without CONSULT: GO TO 11.  
NO >> GO TO 9.

## 9. DETECT MALFUNCTIONING PART

Check the following.

- EVAP canister for damage
- EVAP hose between EVAP canister and vehicle frame for clogging or poor connection

>> Repair hose or replace EVAP canister. Refer to [FL-15, "VK56VD : Hydraulic Layout"](#).

## 10. CHECK EVAP CANISTER PURGE VOLUME CONTROL SOLENOID VALVE OPERATION

### WITH CONSULT

1. Disconnect vacuum hose to EVAP canister purge volume control solenoid valve at EVAP service port.
2. Start engine and let it idle.
3. Select "PURG VOL CONT/V" in "ACTIVE TEST" mode.
4. Touch "Qu" on CONSULT screen to increase "PURG VOL CONT/V" opening to 100%.
5. Check vacuum hose for vacuum.

**Vacuum should exist.**

#### Is the inspection result normal?

- YES >> GO TO 13.  
NO >> GO TO 12.

## 11. CHECK EVAP CANISTER PURGE VOLUME CONTROL SOLENOID VALVE OPERATION

### WITHOUT CONSULT

1. Start engine and warm it up to normal operating temperature.
2. Stop engine.
3. Disconnect vacuum hose to EVAP canister purge volume control solenoid valve at EVAP service port.
4. Start engine and let it idle for at least 80 seconds.
5. Check vacuum hose for vacuum when revving engine up to 2,000 rpm.

**Vacuum should exist.**

#### Is the inspection result normal?

- YES >> GO TO 13.  
NO >> GO TO 12.

## 12. CHECK VACUUM HOSE

Check vacuum hoses for clogging or disconnection. Refer to [FL-15, "VK56VD : Hydraulic Layout"](#).

#### Is the inspection result normal?

## P0456 EVAP CONTROL SYSTEM

[VK56VD FOR USA AND CANADA]

< DTC/CIRCUIT DIAGNOSIS >

- YES >> GO TO 13.  
NO >> Repair or reconnect the hose.

### 13. CHECK EVAP CANISTER PURGE VOLUME CONTROL SOLENOID VALVE

Refer to [EC-1330. "Component Inspection \(EVAP Canister Purge Volume Control Solenoid Valve\)"](#).

Is the inspection result normal?

- YES >> GO TO 14.  
NO >> Replace EVAP canister purge volume control solenoid valve. Refer to [FL-13. "Exploded View"](#).

### 14. CHECK FUEL TANK TEMPERATURE SENSOR

Refer to [EC-1275. "Component Inspection \(Fuel Tank Temperature Sensor\)"](#).

Is the inspection result normal?

- YES >> GO TO 15.  
NO >> Replace fuel level sensor unit. Refer to [FL-6. "Removal and Installation"](#).

### 15. CHECK EVAP CONTROL SYSTEM PRESSURE SENSOR

Refer to [EC-1343. "Component Inspection \(EVAP Control System Pressure Sensor\)"](#).

Is the inspection result normal?

- YES >> GO TO 16.  
NO >> Replace EVAP control system pressure sensor. Refer to [EC-1343. "Component Inspection \(EVAP Control System Pressure Sensor\)"](#).

### 16. CHECK EVAP PURGE LINE

Check EVAP purge line (pipe, rubber tube, fuel tank and EVAP canister) for cracks or improper connection. Refer to [FL-15. "VK56VD : Hydraulic Layout"](#).

Is the inspection result normal?

- YES >> GO TO 17.  
NO >> Repair or reconnect the hose.

### 17. CLEAN EVAP PURGE LINE

Clean EVAP purge line (pipe and rubber tube) using air blower.

>> GO TO 18.

### 18. CHECK EVAP/ORVR LINE

Check EVAP/ORVR line between EVAP canister and fuel tank for clogging, kink, looseness and improper connection. For location, refer to [FL-15. "VK56VD : Hydraulic Layout"](#).

Is the inspection result normal?

- YES >> GO TO 19.  
NO >> Repair or replace hoses and tubes.

### 19. CHECK RECIRCULATION LINE

Check recirculation line between fuel filler tube and fuel tank for clogging, kink, cracks, looseness and improper connection.

Is the inspection result normal?

- YES >> GO TO 20.  
NO >> Repair or replace hose, tube or fuel filler tube. Refer to [FL-10. "Exploded View"](#).

### 20. CHECK REFUELING EVAP VAPOR CUT VALVE

Refer to [EC-1537. "Component Inspection \(EVAP Vapor Cut Valve\)"](#).

Is the inspection result normal?

- YES >> GO TO 21.  
NO >> Replace refueling EVAP vapor cut valve with fuel tank. Refer to [FL-10. "Exploded View"](#).

### 21. CHECK FUEL LEVEL SENSOR

Refer to [MWI-63. "Component Inspection"](#).

Is the inspection result normal?

# P0456 EVAP CONTROL SYSTEM

[VK56VD FOR USA AND CANADA]

< DTC/CIRCUIT DIAGNOSIS >

YES >> GO TO 22.

NO >> Replace fuel level sensor unit. Refer to [FL-6, "Removal and Installation"](#).

## 22.CHECK INTERMITTENT INCIDENT

Refer to [GI-44, "Intermittent Incident"](#).

>> INSPECTION END

## Component Inspection (Fuel Filler Cap)

INFOID:000000007187603

### 1.CHECK FUEL FILLER CAP

1. Turn ignition switch OFF.
2. Remove fuel filler cap. Refer to [FL-10, "Exploded View"](#).
3. Wipe clean valve housing.

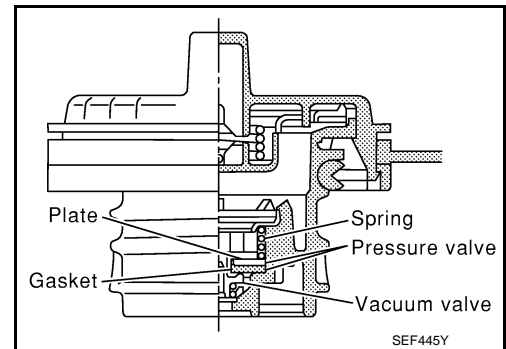

4. Install fuel filler cap adapter (commercial service tool) to fuel filler cap.
5. Check valve opening pressure and vacuum.

**Pressure:** 15.3 - 20.0 kPa (0.156 - 0.204 kg/cm<sup>2</sup>, 2.22 - 2.90 psi)

**Vacuum:** -6.0 to -3.3 kPa (-0.061 to -0.034 kg/cm<sup>2</sup>, -0.87 to -0.48 psi)

Is the inspection result normal?

YES >> INSPECTION END

NO >> GO TO 2.

### 2.REPLACE FUEL FILLER CAP

Replace fuel filler cap. Refer to [FL-10, "Exploded View"](#).

#### **CAUTION:**

**Use only a genuine fuel filler cap as a replacement. If an incorrect fuel filler cap is used, the MIL may illuminate.**

>> INSPECTION END

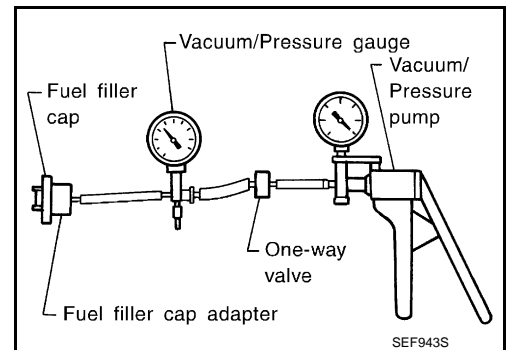



# P0460 FUEL LEVEL SENSOR

< DTC/CIRCUIT DIAGNOSIS >

[VK56VD FOR USA AND CANADA]

## P0460 FUEL LEVEL SENSOR

### DTC Logic

INFOID:000000007187604

#### DTC DETECTION LOGIC

##### NOTE:

- If DTC P0460 is displayed with DTC UXXXX, first perform the trouble diagnosis for DTC UXXXX.
- If DTC P0460 is displayed with DTC P0607, first perform the trouble diagnosis for DTC P0607. Refer to [EC-1386, "DTC Logic"](#).

When the vehicle is parked, the fuel level in the fuel tank is naturally stable. It means that output signal of the fuel level sensor does not change. If ECM senses sloshing signal from the sensor, fuel level sensor malfunction is detected.

| DTC No. | Trouble diagnosis name<br>(Trouble diagnosis content)   | DTC detecting condition   | Possible cause  |
|---------|---|---|---|
| P0460   | FUEL LEV SEN SLOSH<br>(Fuel level sensor circuit noise) | Even though the vehicle is parked, a signal being varied is sent from the fuel level sensor to ECM. | <ul style="list-style-type: none"><li>• Harness or connectors<br/>(The CAN communication line is open or shorted)</li><li>• Harness or connectors<br/>(The sensor circuit is open or shorted)</li><li>• Combination meter</li><li>• Fuel level sensor</li></ul> |

#### DTC CONFIRMATION PROCEDURE

##### 1. PRECONDITIONING

If DTC Confirmation Procedure has been previously conducted, always perform the following procedure before conducting the next test.

1. Turn ignition switch OFF and wait at least 10 seconds.
2. Turn ignition switch ON.
3. Turn ignition switch OFF and wait at least 10 seconds.

>> GO TO 2.

##### 2. PERFORM DTC CONFIRMATION PROCEDURE

1. Start engine and wait maximum of 2 consecutive minutes.
2. Check 1st trip DTC.

Is 1st trip DTC detected?

- YES >> Proceed to [EC-1361, "Diagnosis Procedure"](#).  
NO >> INSPECTION END

#### Diagnosis Procedure

INFOID:000000007187605

##### 1. CHECK DTC WITH "COMBINATION METER"

Refer to [MWI-31, "CONSULT Function"](#).

Is any DTC detected?

- YES >> Perform trouble diagnosis of detected DTC.  
NO >> GO TO 2.

##### 2. CHECK FUEL LEVEL SENSOR SIGNAL CIRCUIT

Check fuel level sensor signal circuit. Refer to [MWI-62, "Component Function Check"](#).

Is the inspection result normal?

- YES >> Check intermittent incident. Refer to [GI-44, "Intermittent Incident"](#).  
NO >> Perform trouble diagnosis of fuel level sensor signal circuit. Refer to [MWI-62, "Diagnosis Procedure"](#).

# P0461 FUEL LEVEL SENSOR

< DTC/CIRCUIT DIAGNOSIS >

[VK56VD FOR USA AND CANADA]

## P0461 FUEL LEVEL SENSOR

### DTC Logic

INFOID:000000007187606

#### DTC DETECTION LOGIC

##### NOTE:

- If DTC P0461 is displayed with DTC UXXXX, first perform the trouble diagnosis for DTC UXXXX.
- If DTC P0461 is displayed with DTC P0607, first perform the trouble diagnosis for DTC P0607. Refer to [EC-1386, "DTC Logic"](#).

Driving long distances naturally affect fuel gauge level.

This diagnosis detects the fuel gauge malfunction of the gauge not moving even after a long distance has been driven.

| DTC No. | Trouble diagnosis name<br>(Trouble diagnosis content)              | DTC detecting condition  | Possible cause  |
|---------|--|--|---|
| P0461   | FUEL LEVEL SENSOR<br>(Fuel level sensor circuit range/performance) | The output signal of the fuel level sensor does not change within the specified range even though the vehicle has been driven a long distance. | <ul style="list-style-type: none"><li>• Harness or connectors<br/>(The CAN communication line is open or shorted)</li><li>• Harness or connectors<br/>(The sensor circuit is open or shorted)</li><li>• Combination meter</li><li>• Fuel level sensor</li></ul> |

#### DTC CONFIRMATION PROCEDURE

### 1. PERFORM COMPONENT FUNCTION CHECK

Perform Component Function Check. Refer to [EC-1362, "Component Function Check"](#).

Use component function check to check the overall function of the fuel level sensor. During this check, a 1st trip DTC might not be confirmed.

Is the inspection result normal?

YES >> INSPECTION END

NO >> Proceed to [EC-1363, "Diagnosis Procedure"](#).

#### Component Function Check

INFOID:000000007187607

### 1. PRECONDITIONING

##### WARNING:

When performing the following procedure, always observe the handling of the fuel. Refer to [FL-2, "General Precautions"](#).

##### TESTING CONDITION:

Before starting component function check, preparation of draining fuel and refilling fuel is required.

>> GO TO 2.

### 2. PERFORM COMPONENT FUNCTION CHECK

##### NOTE:

Start from step 8, if it is possible to confirm that the fuel cannot be drained by 30 ℓ (7-7/8 US gal, 6-5/8 Imp gal) in advance.

1. Prepare a fuel container and a spare hose.
2. Release fuel pressure from fuel line. Refer to [EC-1127, "Work Procedure"](#).
3. Remove the fuel feed hose on the fuel level sensor unit. Refer to [FL-6, "Removal and Installation"](#).
4. Connect a spare fuel hose where the fuel feed hose was removed.
5. Turn ignition switch ON.
6. Drain fuel by 30 ℓ (7-7/8 US gal, 6-5/8 Imp gal) from the fuel tank using proper equipment.
7. Confirm that the fuel gauge indication varies.
8. Fill fuel into the fuel tank for 30 ℓ (7-7/8 US gal, 6-5/8 Imp gal).
9. Confirm that the fuel gauge indication varies.

Is the inspection result normal?

# P0461 FUEL LEVEL SENSOR

[VK56VD FOR USA AND CANADA]

< DTC/CIRCUIT DIAGNOSIS >

- YES >> INSPECTION END
- NO >> Proceed to [EC-1363, "Diagnosis Procedure"](#).

A

## Diagnosis Procedure

INFOID:000000007187608

### 1. CHECK DTC WITH "COMBINATION METER"

EC

Refer to [MWI-31, "CONSULT Function"](#).

Is any DTC detected?

C

- YES >> Perform trouble diagnosis of detected DTC.
- NO >> GO TO 2.

### 2. CHECK FUEL LEVEL SENSOR SIGNAL CIRCUIT

D

Check fuel level sensor signal circuit. Refer to [MWI-62, "Component Function Check"](#).

Is the inspection result normal?

E

- YES >> Check intermittent incident. Refer to [GI-44, "Intermittent Incident"](#).
- NO >> Perform trouble diagnosis of fuel level sensor signal circuit. Refer to [MWI-62, "Diagnosis Procedure"](#).

F

G

H

I

J

K

L

M

N

O

P

# P0462, P0463 FUEL LEVEL SENSOR

< DTC/CIRCUIT DIAGNOSIS >

[VK56VD FOR USA AND CANADA]

## P0462, P0463 FUEL LEVEL SENSOR

### DTC Logic

INFOID:000000007187609

#### DTC DETECTION LOGIC

##### NOTE:

- If DTC P0462 or P0463 is displayed with DTC UXXXX, first perform the trouble diagnosis for DTC UXXXX.
- If DTC P0462 or P0463 is displayed with DTC P0607, first perform the trouble diagnosis for DTC P0607. Refer to [EC-1386, "DTC Logic"](#).

This diagnosis indicates the former, to detect open or short circuit malfunction.

| DTC No. | Trouble diagnosis name<br>(Trouble diagnosis content)        | DTC detecting condition                                     | Possible cause  |
|---------|--|---|---|
| P0462   | FUEL LEVL SEN/CIRC<br>(Fuel level sensor circuit low input)  | An excessively low voltage from the sensor is sent to ECM.  | <ul style="list-style-type: none"><li>• Harness or connectors<br/>(The CAN communication line is open or shorted)</li><li>• Harness or connectors<br/>(The sensor circuit is open or shorted)</li></ul> |
| P0463   | FUEL LEVL SEN/CIRC<br>(Fuel level sensor circuit high input) | An excessively high voltage from the sensor is sent to ECM. | <ul style="list-style-type: none"><li>• Combination meter</li><li>• Fuel level sensor</li></ul>   |

#### DTC CONFIRMATION PROCEDURE

##### 1. PRECONDITIONING

1. Turn ignition switch OFF and wait at least 10 seconds.
2. Turn ignition switch ON.
3. Turn ignition switch OFF and wait at least 10 seconds.

##### TESTING CONDITION:

Before performing the following procedure, confirm that battery voltage is 11 V or more at ignition switch ON.

>> GO TO 2.

##### 2. PERFORM DTC CONFIRMATION PROCEDURE

1. Turn ignition switch ON and wait at least 5 seconds.
2. Check 1st trip DTC.

Is 1st trip DTC detected?

- YES >> Proceed to [EC-1364, "Diagnosis Procedure"](#).  
NO >> INSPECTION END

#### Diagnosis Procedure

INFOID:000000007187610

##### 1. CHECK DTC WITH "COMBINATION METER"

Refer to [MWI-31, "CONSULT Function"](#).

Is any DTC detected?

- YES >> Perform trouble diagnosis of detected DTC.  
NO >> GO TO 2.

##### 2. CHECK FUEL LEVEL SENSOR SIGNAL CIRCUIT

Check fuel level sensor signal circuit. Refer to [MWI-62, "Component Function Check"](#).

Is the inspection result normal?

- YES >> Check intermittent incident. Refer to [GI-44, "Intermittent Incident"](#).  
NO >> Perform trouble diagnosis of fuel level sensor signal circuit. Refer to [MWI-62, "Diagnosis Procedure"](#).

P0500 VSS

Description

INFOID:000000007195232

ECM receives vehicle speed signals from two different paths via CAN communication line: One is from the ABS actuator and electric unit (control unit) via the combination unit and the other is from TCM.

DTC Logic

INFOID:000000007195233

DTC DETECTION LOGIC

NOTE:

- If DTC P0500 is displayed with DTC UXXXX, first perform the trouble diagnosis for DTC UXXXX.
- If DTC P0500 is displayed with DTC P0607, first perform the trouble diagnosis for DTC P0607. Refer to [EC-1386, "DTC Logic"](#).

| DTC No. | Trouble diagnosis<br>(Trouble diagnosis content) | DTC detecting condition  | Possible cause  |
|---------|--|--|---|
| P0500   | VEH SPEED SEN/CIRC<br>(Vehicle speed sensor)     | At 20 km/h (13 MPH), ECM detects the following status continuously for 5 seconds or more: The difference between a vehicle speed calculated by a output speed sensor transmitted from TCM to ECM via CAN communication and the vehicle speed indicated on the combination meter exceeds 15km/h (10 MPH). | <ul style="list-style-type: none"> <li>• Harness or connector (The CAN communication line is open or shorted.)</li> <li>• Combination meter</li> <li>• ABS actuator and electric unit (control unit)</li> <li>• Wheel sensor</li> <li>• TCM</li> <li>• Output speed sensor</li> </ul> |

DTC CONFIRMATION PROCEDURE

1. PRECONDITIONING

If DTC CONFIRMATION PROCEDURE has been previously conducted, always perform the following procedure before conducting the next test.

1. Turn ignition switch OFF and wait at least 10 seconds.
2. Turn ignition switch ON.
3. Turn ignition switch OFF and wait at least 10 seconds.

TESTING CONDITION:

Before performing the following procedure, confirm that battery voltage is 10 V or more at idle.

>> GO TO 2.

2. PERFORM DTC CONFIRMATION PROCEDURE

1. Start engine.
2. Shift the selector lever to D range and wait at least for 2 seconds.
3. Drive the vehicle at least 5 seconds at 20 km/h (13 MPH) or more.

CAUTION:

Always drive vehicle at a safe speed.

NOTE:

This procedure may be conducted with the drive wheels lifted in the shop or by driving the vehicle. If a road test is expected to be easier, it is unnecessary to lift the vehicle.

4. Check 1st trip DTC.

Is 1st trip DTC detected?

- YES >> Proceed to [EC-1365, "Diagnosis Procedure"](#)
- NO >> INSPECTION END

Diagnosis Procedure

INFOID:000000007195234

1. CHECK DTC WITH TCM

Check DTC with TCM. Refer to [TM-60, "CONSULT Function"](#).

Is the inspection result normal?

- YES >> GO TO 2.

## P0500 VSS

[VK56VD FOR USA AND CANADA]

< DTC/CIRCUIT DIAGNOSIS >

---

NO >> Perform trouble shooting relevant to DTC indicated.

### 2.CHECK DTC WITH ABS ACTUATOR AND ELECTRIC UNIT (CONTROL UNIT)

---

Check DTC with ABS actuator and electric unit (control unit). Refer to [BRC-40, "CONSULT Function"](#).

Is the inspection result normal?

YES >> GO TO 3.

NO >> Perform trouble shooting relevant to DTC indicated.

### 3.CHECK DTC WITH COMBINATION METER

---

Check DTC with combination meter. Refer to [MWI-31, "CONSULT Function"](#).

Is the inspection result normal?

YES >> GO TO 4.

NO >> Perform trouble shooting relevant to DTC indicated.

### 4.CHECK OUTPUT SPEED SENSOR

---

Check output speed sensor. Refer to [TM-106, "Diagnosis Procedure"](#).

Is the inspection result normal?

YES >> GO TO 5.

NO >> Replace or replace error-detected parts.

### 5.CHECK WHEEL SENSOR

---

Check wheel sensor. Refer to [BRC-75, "Diagnosis Procedure"](#).

Is the inspection result normal?

YES >> Check intermittent incident. Refer to [GI-44, "Intermittent Incident"](#).

NO >> Replace or replace error-detected parts.

P0506 ISC SYSTEM

Description

INFOID:000000007187615

The ECM controls the engine idle speed to a specified level through the fine adjustment of the air, which is let into the intake manifold, by operating the electric throttle control actuator. The operating of the throttle valve is varied to allow for optimum control of the engine idling speed. The crankshaft position sensor detects the actual engine speed and sends a signal to the ECM.

The ECM controls the electric throttle control actuator so that the engine speed coincides with the target value memorized in the ECM. The target engine speed is the lowest speed at which the engine can operate steadily. The optimum value stored in the ECM is determined by taking into consideration various engine conditions, such as during warming up, deceleration and engine load (air conditioner, power steering and cooling fan operation, etc.).

DTC Logic

INFOID:000000007187616

DTC DETECTION LOGIC

NOTE:

If DTC P0506 is displayed with other DTC, first perform the trouble diagnosis for the other DTC.

| DTC No. | Trouble diagnosis name<br>(Trouble diagnosis content)                | DTC detecting condition   | Possible cause   |
|---------|--|---|--|
| P0506   | ISC SYSTEM<br>(Idle speed control system<br>RPM lower than expected) | The idle speed is less than the target idle speed by 100 rpm or more. | <ul style="list-style-type: none"> <li>• Electric throttle control actuator</li> <li>• Intake air leakage</li> </ul> |

DTC CONFIRMATION PROCEDURE

1. PRECONDITIONING

1. Turn ignition switch OFF and wait at least 10 seconds.
2. Turn ignition switch ON.
3. Turn ignition switch OFF and wait at least 10 seconds.

If the target idle speed is out of the specified value, perform [EC-1122, "Work Procedure"](#), before conducting DTC Confirmation Procedure.

TESTING CONDITION:

- Before performing the following procedure, confirm that battery voltage is 11 V or more at idle.
- Always perform the test at a temperature above -10°C (14°F).

>> GO TO 2.

2. PERFORM DTC CONFIRMATION PROCEDURE

1. Start engine and warm it up to normal operating temperature.
2. Turn ignition switch OFF and wait at least 10 seconds.
3. Turn ignition switch ON.
4. Turn ignition switch OFF and wait at least 10 seconds.
5. Restart engine and run it for at least 1 minute at idle speed.
6. Check 1st trip DTC.

Is 1st trip DTC detected?

YES >> Proceed to [EC-1367, "Diagnosis Procedure"](#).

NO >> INSPECTION END

Diagnosis Procedure

INFOID:000000007187617

1. CHECK INTAKE AIR LEAKAGE

1. Start engine and let it idle.
2. Listen for an intake air leakage after the mass air flow sensor.

Is intake air leakage detected?

YES >> Discover air leakage location and repair.

## P0506 ISC SYSTEM

< DTC/CIRCUIT DIAGNOSIS >

[VK56VD FOR USA AND CANADA]

---

NO >> GO TO 2.

### 2. REPLACE ECM

---

1. Stop engine.
2. Replace ECM. Refer to [EC-1553, "Removal and Installation"](#).
3. Perform additional service when replacing ECM. Refer to [EC-1117, "Work Procedure"](#).

>> INSPECTION END



P0507 ISC SYSTEM

Description

INFOID:000000007187618

The ECM controls the engine idle speed to a specified level through the fine adjustment of the air, which is let into the intake manifold, by operating the electric throttle control actuator. The operating of the throttle valve is varied to allow for optimum control of the engine idling speed. The crankshaft position sensor detects the actual engine speed and sends a signal to the ECM.

The ECM controls the electric throttle control actuator so that the engine speed coincides with the target value memorized in the ECM. The target engine speed is the lowest speed at which the engine can operate steadily. The optimum value stored in the ECM is determined by taking into consideration various engine conditions, such as during warming up, deceleration and engine load (air conditioner, power steering and cooling fan operation, etc.).

DTC Logic

INFOID:000000007187619

DTC DETECTION LOGIC

NOTE:

If DTC P0507 is displayed with other DTC, first perform the trouble diagnosis for the other DTC.

| DTC No. | Trouble diagnosis name<br>(Trouble diagnosis content)                 | DTC detecting condition   | Possible cause   |
|---------|---|---|--|
| P0507   | ISC SYSTEM<br>(Idle speed control system<br>RPM higher than expected) | The idle speed is more than the target idle speed by 200 rpm or more. | <ul style="list-style-type: none"> <li>• Electric throttle control actuator</li> <li>• Intake air leakage</li> <li>• PCV system</li> </ul> |

DTC CONFIRMATION PROCEDURE

1. PRECONDITIONING

1. Turn ignition switch OFF and wait at least 10 seconds.
2. Turn ignition switch ON.
3. Turn ignition switch OFF and wait at least 10 seconds.

If the target idle speed is out of the specified value, perform [EC-1122. "Work Procedure"](#), before conducting DTC Confirmation Procedure.

TESTING CONDITION:

- Before performing the following procedure, confirm that battery voltage is 11 V or more at idle.
- Always perform the test at a temperature above -10°C (14°F).

>> GO TO 2.

2. PERFORM DTC CONFIRMATION PROCEDURE

1. Start engine and warm it up to normal operating temperature.
2. Turn ignition switch OFF and wait at least 10 seconds.
3. Turn ignition switch ON.
4. Turn ignition switch OFF and wait at least 10 seconds.
5. Start engine and run it for at least 1 minute at idle speed.
6. Check 1st trip DTC.

Is 1st trip DTC detected?

- YES >> Proceed to [EC-1369. "Diagnosis Procedure"](#).  
 NO >> INSPECTION END

Diagnosis Procedure

INFOID:000000007187620

1. CHECK PCV HOSE CONNECTION

Confirm that PCV hose is connected correctly.

Is the inspection result normal?

- YES >> GO TO 2.  
 NO >> Repair or replace malfunctioning part.

**2.CHECK INTAKE AIR LEAKAGE**

---

1. Start engine and let it idle.
2. Listen for an intake air leakage after the mass air flow sensor.

Is intake air leakage detected?

YES >> Discover air leakage location and repair.

NO >> GO TO 3.

**3.REPLACE ECM**

---

1. Stop engine.
2. Replace ECM. Refer to [EC-1553, "Removal and Installation"](#).
3. Perform additional service when replacing ECM. Refer to [EC-1117, "Work Procedure"](#).

>> INSPECTION END

# P050A, P050B, P050E COLD START CONTROL

< DTC/CIRCUIT DIAGNOSIS >

[VK56VD FOR USA AND CANADA]

## P050A, P050B, P050E COLD START CONTROL

### Description

INFOID:000000006883498

ECM controls ignition timing and engine idle speed when engine is started with pre-warming up condition. This control promotes the activation of three way catalyst by heating the catalyst and reduces emissions.

### DTC Logic

INFOID:000000006883499

### DTC DETECTION LOGIC

#### NOTE:

If DTC P050A, P050B or P050E is displayed with other DTC, first perform the trouble diagnosis for other DTC.

| DTC No. | Trouble diagnosis name                         | DTC detecting condition   | Possible cause  |
|---------|--|---|---|
| P050A   | Cold start idle air control system performance | ECM does not control engine idle speed properly when engine is started with pre-warming up condition.                                   | <ul style="list-style-type: none"><li>• Lack of intake air volume</li><li>• Fuel injection system</li><li>• ECM</li></ul> |
| P050B   | Cold start ignition timing performance         | ECM does not control ignition timing properly when engine is started with pre-warming up condition.                                     |   |
| P050E   | Cold start engine exhaust temperature too low  | The temperature of the catalyst inlet does not rise to the proper temperature when the engine is started with pre-warming up condition. |   |

### DTC CONFIRMATION PROCEDURE

#### 1. PRECONDITIONING

If DTC Confirmation Procedure has been previously conducted, always perform the following procedure before conducting the next test.

1. Turn ignition switch OFF and wait at least 10 seconds.
2. Turn ignition switch ON.
3. Turn ignition switch OFF and wait at least 10 seconds.

#### TESTING CONDITION:

Before performing the following procedure, confirm that battery voltage is 11 V or more at idle.

>> GO TO 2.

#### 2. PERFORM DTC CONFIRMATION PROCEDURE-I

##### Ⓜ WITH CONSULT

1. Turn ignition switch OFF and wait at least 10 seconds.
2. Turn ignition switch ON.
3. Select "DATA MONITOR" mode with CONSULT.
4. Check the indication of "COOLAN TEMP/S".

##### Ⓜ WITH GST

Follow the procedure "With CONSULT" above.

Is the value of "COOLAN TEMP/S" between 4°C (39°F) and 36°C (97°F)?

YES >> GO TO 3.

NO-1 [If it is below 4°C (39°F)]>>Warm up the engine until the value of "COOLAN TEMP/S" reaches 4°C (39°F) or more. Retry from step 1.

NO-2 [If it is above 36°C (97°F)]>>Cool engine down to less than 36°C (97°F). Retry from step 1.

#### 3. PERFORM DTC CONFIRMATION PROCEDURE-II

##### Ⓜ WITH CONSULT

1. Set the select lever in N range.
2. Start the engine and warm up in idle with the value of "COOLAN TEMP/S" between 4°C (39°F) and 40°C (104°F) for more than 15 seconds.
3. Check 1st trip DTC.

# P050A, P050B, P050E COLD START CONTROL

[VK56VD FOR USA AND CANADA]

< DTC/CIRCUIT DIAGNOSIS >

 WITH GST

Follow the procedure "With CONSULT" above.

Is 1st trip DTC detected?

YES >> Proceed to [EC-1372, "Diagnosis Procedure"](#).

NO >> INSPECTION END

## Diagnosis Procedure

INFOID:000000006883500

### 1. PERFORM IDLE AIR VOLUME LEARNING

Perform [EC-1122, "Work Procedure"](#).

Is Idle Air Volume Learning carried out successfully?

YES >> GO TO 2.

NO >> Follow the instruction of Idle Air Volume Learning.

### 2. CHECK INTAKE SYSTEM

Check for the cause of intake air volume lacking. Refer to the following.

- Crushed intake air passage
- Intake air passage clogging
- Clogging of throttle body

Is the inspection result normal?

YES >> GO TO 3.

NO >> Repair or replace malfunctioning part

### 3. CHECK FUEL INJECTION SYSTEM FUNCTION

Perform DTC Confirmation Procedure for DTC P0171, P0174. Refer to [EC-1264, "DTC Logic"](#).

Is the inspection result normal?

YES >> GO TO 4.

NO >> Proceed to [EC-1265, "Diagnosis Procedure"](#) for DTC P0171, P0174.

### 4. PERFORM DTC CONFIRMATION PROCEDURE

1. Turn ignition switch ON.
2. Erase DTC.
3. Perform DTC Confirmation Procedure.  
See [EC-1371, "DTC Logic"](#).

Is the 1st trip DTC P050A, P050B or P050E displayed again?

YES >> GO TO 5.

NO >> INSPECTION END

### 5. REPLACE ECM

Replace ECM. Refer to [EC-1553, "Removal and Installation"](#).

>> INSPECTION END

# P0520 EOP SENSOR

< DTC/CIRCUIT DIAGNOSIS >

[VK56VD FOR USA AND CANADA]

## P0520 EOP SENSOR

### DTC Logic

INFOID:000000007187624

### DTC DETECTION LOGIC

| DTC No. | Trouble diagnosis<br>(Trouble diagnosis content) | Detecting condition   | Possible cause   |
|---------|--|---|--|
| P0520   | EOP sensor circuit                               | Signal voltage from the EOP sensor remains at more than 4.9 V / less than 0.26 V for 5 seconds or more. | <ul style="list-style-type: none"><li>• Harness or connectors (EOP sensor circuit is open or shorted.) (Power steering pressure sensor circuit is open or shorted.) (Low fuel pressure sensor circuit is open or shorted.) (FRP sensor circuit is open or shorted.)</li><li>• Engine oil level abnormality</li><li>• EOP sensor</li><li>• Power steering pressure sensor</li><li>• Low fuel pressure sensor</li><li>• FRP sensor</li></ul> |

### DTC CONFIRMATION PROCEDURE

#### 1. PRECONDITIONING

If DTC Confirmation Procedure has been previously conducted, always perform the following procedure before conducting the next test.

1. Turn ignition switch OFF and wait at least 10 seconds.
2. Turn ignition switch ON.
3. Turn ignition switch OFF and wait at least 10 seconds.

>> GO TO 2.

#### 2. PERFORM DTC CONFIRMATION PROCEDURE

1. Turn ignition switch ON and wait at least 5 seconds.
2. Check 1st trip DTC.

Is 1st trip DTC detected?

- YES >> Proceed to [EC-1373, "Diagnosis Procedure"](#).  
NO >> INSPECTION END

### Diagnosis Procedure

INFOID:000000007187625

#### 1. CHECK ENGINE OIL

1. Turn ignition switch OFF.
2. Check engine oil level and pressure. Refer to [LU-23, "Inspection"](#).

Is inspection result normal?

- YES >> GO TO 2.  
NO >> Repair or replace error-detected parts.

#### 2. CHECK EOP SENSOR POWER SUPPLY-I

1. Disconnect EOP sensor connector.
2. Turn ignition switch ON.
3. Check the voltage between EOP sensor harness connector terminals.

# P0520 EOP SENSOR

< DTC/CIRCUIT DIAGNOSIS >

[VK56VD FOR USA AND CANADA]

| EOP sensor |          |   | Voltage<br>(Approx.) |
|------------|----------|---|----------------------|
| Connector  | +        | - |                      |
|            | terminal |   |                      |
| F32        | 3        | 1 | 5 V                  |

Inspection result normal?

- YES >> GO TO 7.  
NO >> GO TO 3.

## 3.CHECK EOP SENSOR POWER SUPPLY-II

Check the voltage between EOP sensor harness connector and the ground.

| +          |          | -      | Voltage<br>(Approx.) |
|------------|----------|--------|----------------------|
| EOP sensor |          |        |                      |
| Connector  | Terminal |        |                      |
| F32        | 3        | Ground | 5 V                  |

Is inspection result normal?

- YES >> GO TO 5.  
NO >> GO TO 4.

## 4.CHECK SENSOR POWER SUPPLY CIRCUIT

1. Turn ignition switch OFF.
2. Disconnect ECM harness connector.
3. Check harness connector for short to power and short to ground, between the following terminals.

| ECM       |          | Sensor                         |           |          |
|-----------|----------|--------------------------------|-----------|----------|
| Connector | Terminal | Name                           | Connector | Terminal |
| F110      | 27       | Power steering pressure sensor | F35       | 3        |
|           |          | Low fuel pressure sensor       | F39       | 3        |
|           | 28       | FRP sensor                     | F6        | 1        |
|           |          | Engine oil pressure sensor     | F32       | 3        |

Is inspection result normal?

- YES >> Perform the trouble diagnosis for power supply circuit. Refer to [EC-1149, "Diagnosis Procedure"](#).  
NO >> Repair or replace error-detected parts.

## 5.CHECK EOP SENSOR GROUND CIRCUIT

1. Turn ignition switch OFF.
2. Disconnect ECM harness connector.
3. Check the continuity between EOP sensor harness connector and ECM harness connector.

| +          |          | -         |          | Continuity |
|------------|----------|-----------|----------|------------|
| EOP sensor |          | ECM       |          |            |
| Connector  | Terminal | Connector | Terminal |            |
| F32        | 1        | F110      | 40       | Existed    |

Is inspection result normal?

- YES >> GO TO 6.  
NO >> Repair or replace error-detected parts.

## 6.CHECK ECM GROUND CIRCUIT

Check the continuity between ECM harness connector and ground.

# P0520 EOP SENSOR

< DTC/CIRCUIT DIAGNOSIS >

[VK56VD FOR USA AND CANADA]

| ECM       |          | Ground | Continuity |
|-----------|----------|--------|------------|
| Connector | Terminal |        |            |
| F110      | 10       | Ground | Existed    |
| M160      | 114      |        |            |
|           | 115      |        |            |
|           | 174      |        |            |
|           | 175      |        |            |

Is inspection result normal?

- YES >> Check intermittent incident. Refer to [GI-44, "Intermittent Incident"](#).  
 NO >> Repair or replace error-detected parts.

## 7. CHECK EOP SENSOR SIGNAL CIRCUIT

- Turn ignition switch OFF.
- Disconnect ECM harness connector.
- Check the continuity between EOP sensor harness connector and ECM harness connector.

| +          |          | -         |          | Continuity |
|------------|----------|-----------|----------|------------|
| EOP sensor |          | ECM       |          |            |
| Connector  | Terminal | Connector | Terminal |            |
| F32        | 2        | F110      | 41       | Existed    |

- Also check harness for short to ground and to power.

Is inspection result normal?

- YES >> GO TO 8.  
 NO >> Repair or replace error-detected parts.

## 8. CHECK EOP SENSOR

Refer to [EC-1375, "Component Inspection \(EOP sensor\)"](#).

Is inspection result normal?

- YES >> Check intermittent incident. Refer to [GI-44, "Intermittent Incident"](#).  
 NO >> Repair or replace error-detected parts.

## Component Inspection (EOP sensor)

INFOID:000000007187626

### 1. CHECK EOP SENSOR

- Turn ignition switch OFF.
- Disconnect EOP sensor harness connector.
- Check resistance between EOP sensor connector terminals.

| +          | - | Condition | Resistance (kΩ) |
|------------|---|-----------|-----------------|
| EOP sensor |   |           |                 |
| Terminal   |   |           |                 |
| 1          | 2 | None      | 4 kΩ – 10 kΩ    |
|            | 3 |           | 2 kΩ – 8 kΩ     |
| 2          | 1 |           | 4 kΩ – 10 kΩ    |
|            | 3 |           | 1 kΩ – 3 kΩ     |
| 3          | 1 |           | 2 kΩ – 8 kΩ     |
|            | 2 |           | 1 kΩ – 3 kΩ     |

Is the inspection result normal?

- YES >> INSPECTION END.  
 NO >> Replace EOP sensor. Refer to [EM-226, "Exploded View"](#).

# P0524 ENGINE OIL PRESSURE

< DTC/CIRCUIT DIAGNOSIS >

[VK56VD FOR USA AND CANADA]

## P0524 ENGINE OIL PRESSURE

### DTC Logic

INFOID:000000007187627

### DTC DETECTION LOGIC

#### NOTE:

If DTC P0524 is displayed with DTC P0520, P0075, or P0081, perform trouble diagnosis for DTC P0520, P0075, or P0081 first. Refer to [EC-1179, "DTC Logic"](#).

| DTC No. | Trouble diagnosis name<br>(Trouble diagnosis content) | Detecting condition  | Possible cause   |
|---------|---|--|--|
| P0524   | ENGINE OIL PRESSURE<br>(Engine oil pressure too low)  | Engine oil pressure is low because there is a gap between angle of target and phase-control angle. | <ul style="list-style-type: none"><li>• Engine oil pressure or level too low</li><li>• Crankshaft position sensor</li><li>• Camshaft position sensor</li><li>• Intake valve timing control solenoid valve</li><li>• Accumulation of debris to the signal pick-up portion of the camshaft</li><li>• Timing chain installation</li><li>• Foreign matter caught in the oil groove for intake valve timing control</li></ul> |

### DTC CONFIRMATION PROCEDURE

#### 1. PRECONDITIONING-I

1. Turn ignition switch OFF and wait at least 10 seconds.
2. Turn ignition switch ON.
3. Turn ignition switch OFF and wait at least 10 seconds.

#### TESTING CONDITION:

Before performing the following procedure, confirm that battery voltage is between 10 V and 16 V at idle.

>> GO TO 2.

#### 2. PRECONDITIONING-II

Check oil level and oil pressure. Refer to [LU-23, "Inspection"](#).

Is the inspection result normal?

YES >> GO TO 3.

NO >> Proceed to [LU-23, "Inspection"](#).

#### 3. PERFORM DTC CONFIRMATION PROCEDURE

##### WITH CONSULT

1. Select "DATA MONITOR" mode with CONSULT.
2. Maintain the following conditions for at least 20 consecutive seconds.

|                         |   |
|-------------------------|---|
| ENG SPEED               | More than 1,700 rpm   |
| COOLAN TEMP/S           | More than 70°C (158°F)  |
| Selector lever          | 1st or 2nd position   |
| Driving location uphill | Driving vehicle uphill<br>(Increased engine load will help maintain the driving conditions required for this test.) |

#### CAUTION:

**Always drive at a safe speed.**

3. Check 1st trip DTC.

##### WITH GST

Follow the procedure "With CONSULT" above.

Is 1st trip DTC detected?

YES >> Proceed to [EC-1377, "Diagnosis Procedure"](#)



# P0524 ENGINE OIL PRESSURE

[VK56VD FOR USA AND CANADA]

< DTC/CIRCUIT DIAGNOSIS >

NO >> INSPECTION END

## Diagnosis Procedure

INFOID:000000007187628

### 1. CHECK OIL PRESSURE WARNING LAMP

1. Start engine.
2. Check oil pressure warning lamp and confirm it is not illuminated.

Is oil pressure warning lamp illuminated?

- YES >> Proceed to [LU-23, "Inspection"](#).  
NO >> GO TO 2.

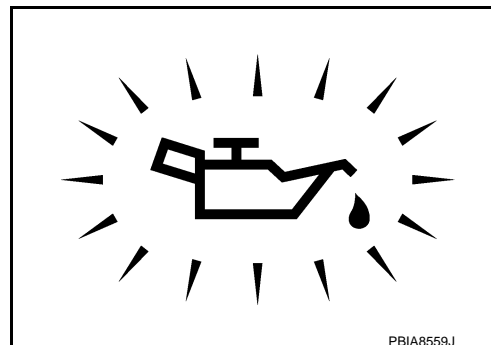

### 2. CHECK INTAKE VALVE TIMING CONTROL SOLENOID VALVE

Refer to [EC-1167, "Component Inspection \(Intake Valve Timing Control Solenoid Valve\)"](#).

Is the inspection result normal?

- YES >> GO TO 3.  
NO >> Replace malfunctioning intake valve timing control solenoid valve. Refer to [EM-231, "Exploded View"](#).

### 3. CHECK CRANKSHAFT POSITION SENSOR

Refer to [EC-1307, "Component Inspection \(Crankshaft Position Sensor\)"](#).

Is the inspection result normal?

- YES >> GO TO 4.  
NO >> Replace crankshaft position sensor. Refer to [EM-226, "Exploded View"](#).

### 4. CHECK CAMSHAFT POSITION SENSOR

Refer to [EC-1312, "Component Inspection \(Camshaft Position Sensor\)"](#).

Is the inspection result normal?

- YES >> GO TO 5.  
NO >> Replace malfunctioning camshaft position sensor. Refer to [EM-231, "Exploded View"](#).

### 5. CHECK CAMSHAFT SPROCKET (SIGNAL PLATE)

Check the following.

- Accumulation of debris to the signal plate of camshaft sprocket (INT)
- Chipping signal plate of camshaft sprocket (INT)

Is the inspection result normal?

- YES >> GO TO 6.  
NO >> Remove debris and clean the signal plate of camshaft sprocket (INT) or replace camshaft sprocket (INT). Refer to [EM-231, "Exploded View"](#).

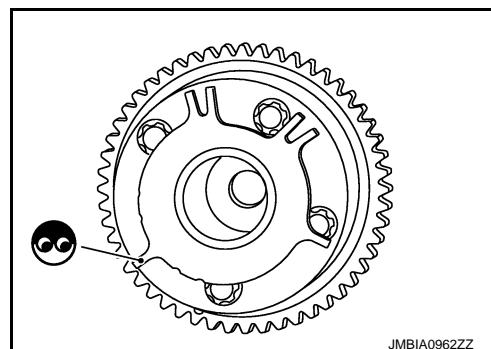

### 6. CHECK TIMING CHAIN INSTALLATION

Check service records for any recent repairs that may cause timing chain misaligned.

Are there any service records that may cause timing chain misaligned?

- YES >> Check timing chain installation. Refer to [EM-231, "Exploded View"](#).  
NO >> GO TO 7.

### 7. CHECK LUBRICATION CIRCUIT

## P0524 ENGINE OIL PRESSURE

< DTC/CIRCUIT DIAGNOSIS >

[VK56VD FOR USA AND CANADA]

---

Perform "Inspection of Camshaft Sprocket (INT) Oil Groove". Refer to [EM-255, "Inspection"](#).

Is the inspection result normal?

YES >> GO TO 8.

NO >> Clean lubrication line.

**8**.CHECK INTERMITTENT INCIDENT

---

Refer to [GI-44, "Intermittent Incident"](#).

>> INSPECTION END

# P0550 PSP SENSOR

< DTC/CIRCUIT DIAGNOSIS >

[VK56VD FOR USA AND CANADA]

## P0550 PSP SENSOR

### DTC Logic

INFOID:000000007187629

### DTC DETECTION LOGIC

| DTC No. | Trouble diagnosis name<br>(Trouble diagnosis content)        | DTC detecting condition  | Possible cause  |
|---------|--|--|---|
| P0550   | PW ST P SEN/CIRC<br>(Power steering pressure sensor circuit) | An excessively low or high voltage from the sensor is sent to ECM. | <ul style="list-style-type: none"> <li>• Harness or connectors<br/>(Power steering pressure sensor circuit is open or shorted.)<br/>(EOP sensor circuit is open or shorted.)<br/>(Low fuel pressure sensor circuit is open or shorted.)<br/>(FRP sensor circuit is open or shorted.)</li> <li>• Power steering pressure sensor</li> <li>• EOP sensor</li> <li>• Low fuel pressure sensor</li> <li>• FRP sensor</li> </ul> |

### DTC CONFIRMATION PROCEDURE

#### 1. PRECONDITIONING

If DTC Confirmation Procedure has been previously conducted, always perform the following procedure before conducting the next test.

1. Turn ignition switch OFF and wait at least 10 seconds.
2. Turn ignition switch ON.
3. Turn ignition switch OFF and wait at least 10 seconds.

>> GO TO 2.

#### 2. PERFORM DTC CONFIRMATION PROCEDURE

1. Start engine and let it idle for at least 5 seconds.
2. Check 1st trip DTC.

##### Is 1st trip DTC detected?

- YES >> Proceed to [EC-1379, "Diagnosis Procedure"](#).  
 NO >> INSPECTION END

### Diagnosis Procedure

INFOID:000000007187630

#### 1. CHECK POWER STEERING PRESSURE SENSOR POWER SUPPLY-I

1. Disconnect power steering pressure (PSP) sensor connector.
2. Turn ignition switch ON.
3. Check the voltage between PSP sensor harness connector terminals.

| Connector | PSP sensor |   | Voltage<br>(Approx.) |
|-----------|------------|---|----------------------|
|           | +          | - |                      |
| F35       | 3          | 1 | 5 V                  |

##### Inspection result normal?

- YES >> GO TO 6.  
 NO >> GO TO 2.

#### 2. CHECK POWER STEERING PRESSURE SENSOR POWER SUPPLY-II

Check the voltage between PSP sensor harness connector and the ground.

# P0550 PSP SENSOR

< DTC/CIRCUIT DIAGNOSIS >

[VK56VD FOR USA AND CANADA]

| +          |          | -      | Voltage<br>(Approx.) |
|------------|----------|--------|----------------------|
| PSP sensor |          |        |                      |
| Connector  | Terminal |        |                      |
| F35        | 3        | Ground | 5 V                  |

Is inspection result normal?

- YES >> GO TO 4.  
NO >> GO TO 3.

## 3.CHECK SENSOR POWER SUPPLY CIRCUIT

1. Turn ignition switch OFF.
2. Disconnect ECM harness connector.
3. Check harness connector for short to power and short to ground, between the following terminals.

| ECM       |          | Sensor                         |           |          |
|-----------|----------|--------------------------------|-----------|----------|
| Connector | Terminal | Name                           | Connector | Terminal |
| F110      | 27       | Power steering pressure sensor | F35       | 3        |
|           |          | Low fuel pressure sensor       | F39       | 3        |
|           | 28       | FRP sensor                     | F6        | 1        |
|           |          | Engine oil pressure sensor     | F32       | 3        |

Is inspection result normal?

- YES >> Perform the trouble diagnosis for power supply circuit. Refer to [EC-1149, "Diagnosis Procedure"](#).  
NO >> Repair or replace error-detected parts.

## 4.CHECK PSP SENSOR GROUND CIRCUIT

1. Turn ignition switch OFF.
2. Disconnect ECM harness connector.
3. Check the continuity between PSP sensor harness connector and ECM harness connector.

| +          |          | -         |          | Continuity |
|------------|----------|-----------|----------|------------|
| PSP sensor |          | ECM       |          |            |
| Connector  | Terminal | Connector | Terminal |            |
| F35        | 1        | F110      | 45       | Existed    |

Is inspection result normal?

- YES >> GO TO 5.  
NO >> Repair or replace error-detected parts.

## 5.CHECK ECM GROUND CIRCUIT

Check the continuity between ECM harness connector and ground.

| ECM       |          | Ground | Continuity |
|-----------|----------|--------|------------|
| Connector | Terminal |        |            |
| F110      | 10       | Ground | Existed    |
|           | 114      |        |            |
|           | 115      |        |            |
|           | 174      |        |            |
|           | 175      |        |            |

Is inspection result normal?

- YES >> Check intermittent incident. Refer to [GI-44, "Intermittent Incident"](#).  
NO >> Repair or replace error-detected parts.

# P0550 PSP SENSOR

< DTC/CIRCUIT DIAGNOSIS >

[VK56VD FOR USA AND CANADA]

## 6. CHECK PSP SENSOR SIGNAL CIRCUIT

1. Turn ignition switch OFF.
2. Disconnect ECM harness connector.
3. Check the continuity between PSP sensor harness connector and ECM harness connector.

| +          |          | -         |          | Continuity |
|------------|----------|-----------|----------|------------|
| PSP sensor |          | ECM       |          |            |
| Connector  | Terminal | Connector | Terminal |            |
| F35        | 2        | F110      | 39       | Existed    |

4. Also check harness for short to ground and to power.

Is inspection result normal?

YES >> GO TO 7.

NO >> Repair or replace error-detected parts.

## 7. CHECK PSP SENSOR

Refer to [EC-1381, "Component Inspection \(Power Steering Pressure Sensor\)"](#).

Is inspection result normal?

YES >> Check intermittent incident. Refer to [GI-44, "Intermittent Incident"](#).

NO >> Repair or replace error-detected parts.

## Component Inspection (Power Steering Pressure Sensor)

INFOID:000000007187631

### 1. CHECK POWER STEERING PRESSURE SENSOR

1. Turn ignition switch OFF.
2. Reconnect all harness connectors disconnected.
3. Start engine and let it idle.
4. Check the voltage between ECM harness connector terminals under the following conditions.

| Connector | ECM      |          | Condition        | Voltage (V)  |           |
|-----------|----------|----------|------------------|--------------|-----------|
|           | +        | -        |                  |              |           |
|           | Terminal | Terminal |                  |              |           |
| F110      | 39       | 45       | Steering wheel   | Being turned | 0.5 - 4.5 |
|           |          |          | Not being turned | 0.4 - 0.8    |           |

Is the inspection result normal?

YES >> INSPECTION END

NO >> Replace power steering pressure sensor. Refer to [ST-76, "2WD : Exploded View"](#) (2WD models) or [ST-78, "AWD : Exploded View"](#) (AWD models).

# P0603 ECM POWER SUPPLY

< DTC/CIRCUIT DIAGNOSIS >

[VK56VD FOR USA AND CANADA]

## P0603 ECM POWER SUPPLY

### DTC Logic

INFOID:000000007187632

### DTC DETECTION LOGIC

| DTC No. | Trouble diagnosis name<br>(Trouble diagnosis content) | DTC detecting condition                            | Possible cause   |
|---------|---|--|--|
| P0603   | ECM BACK UP/CIRCUIT<br>(ECM power supply circuit)     | ECM back up RAM system does not function properly. | <ul style="list-style-type: none"><li>• Harness or connectors<br/>[ECM power supply (back up) circuit is open or shorted.]</li><li>• ECM</li></ul> |

### DTC CONFIRMATION PROCEDURE

#### 1. PRECONDITIONING

If DTC Confirmation Procedure has been previously conducted, always perform the following procedure before conducting the next test.

1. Turn ignition switch OFF and wait at least 10 seconds.
2. Turn ignition switch ON.
3. Turn ignition switch OFF and wait at least 10 seconds.

>> GO TO 2.

#### 2. PERFORM DTC CONFIRMATION PROCEDURE

1. Turn ignition switch ON wait at least 10 seconds.
2. Turn ignition switch OFF and wait at least 5 minutes.
3. Turn ignition switch ON, wait at least 10 seconds.
4. Repeat step 2 and 3 for five times.
5. Check 1st trip DTC.

Is 1st trip DTC detected?

- YES >> Proceed to [EC-1382. "Diagnosis Procedure"](#).  
NO >> INSPECTION END

### Diagnosis Procedure

INFOID:000000007187633

#### 1. CHECK ECM POWER SUPPLY

1. Turn ignition switch OFF.
2. Disconnect ECM harness connector.
3. Check the voltage between ECM harness connector terminals.

| ECM       |          |           |          | Voltage         |
|-----------|----------|-----------|----------|-----------------|
| +         |          | -         |          |                 |
| Connector | Terminal | Connector | Terminal |                 |
| M160      | 156      | M160      | 175      | Battery voltage |

Is the inspection result normal?

- YES >> GO TO 3.  
NO >> GO TO 2.

#### 2. DETECT MALFUNCTIONING PART

Check the following.

- 15 A fuse (No. 51)
- Harness for open or short between ECM and battery
- Loose or poor connection for each connector and harness

>> Repair or replace harness or connectors.

# P0603 ECM POWER SUPPLY

< DTC/CIRCUIT DIAGNOSIS >

[VK56VD FOR USA AND CANADA]

---

## 3.CHECK INTERMITTENT INCIDENT

---

Refer to [GI-44, "Intermittent Incident"](#).

Is the inspection result normal?

YES >> GO TO 4.

NO >> Repair or replace harness or connectors.

---

## 4.PERFORM DTC CONFIRMATION PROCEDURE

---

1. Turn ignition switch ON.
2. Erase DTC.
3. Perform DTC Confirmation Procedure.  
See [EC-1382, "DTC Logic"](#).

Is the 1st trip DTC P0603 displayed again?

YES >> GO TO 5.

NO >> INSPECTION END

---

## 5.REPLACE ECM

---

Replace ECM. Refer to [EC-1553, "Removal and Installation"](#).

>> INSPECTION END

A

EC

C

D

E

F

G

H

I

J

K

L

M

N

O

P

P0605 ECM

DTC Logic

INFOID:000000007187634

DTC DETECTION LOGIC

| DTC No. | Trouble diagnosis name | DTC detecting condition |   | Possible cause |
|---------|------------------------|-------------------------|---|----------------|
| P0605   | Engine control module  | A)                      | ECM calculation function is malfunctioning.   | ECM            |
|         |                        | B)                      | ECM EEPROM system is malfunctioning.          |                |
|         |                        | C)                      | ECM self shut-off function is malfunctioning. |                |
|         |                        | D)                      | ECM temperature sensor is malfunctioning.     |                |

DTC CONFIRMATION PROCEDURE

1. PRECONDITIONING

1. Turn ignition switch OFF and wait at least 10 seconds.
2. Turn ignition switch ON.
3. Turn ignition switch OFF and wait at least 10 seconds.

**TESTING CONDITION:**

**Before performing the following procedure, confirm that battery voltage is 11 V or more at idle.**

>> GO TO 2.

2. PERFORM DTC CONFIRMATION PROCEDURE FOR MALFUNCTION A AND D

1. Turn ignition switch ON.
2. Check 1st trip DTC.

Is 1st trip DTC detected?

- YES >> Proceed to [EC-1384, "Diagnosis Procedure"](#).
- NO >> GO TO 3.

3. PERFORM DTC CONFIRMATION PROCEDURE FOR MALFUNCTION B

1. Turn ignition switch ON and wait at least 1 second.
2. Turn ignition switch OFF, wait at least 10 seconds, and then turn it ON.
3. Check 1st trip DTC.

Is 1st trip DTC detected?

- YES >> Proceed to [EC-1384, "Diagnosis Procedure"](#).
- NO >> GO TO 4.

4. PERFORM DTC CONFIRMATION PROCEDURE FOR MALFUNCTION C

1. Turn ignition switch ON and wait at least 1 second.
2. Turn ignition switch OFF, wait at least 10 seconds, and then turn it ON.
3. Repeat step 2 for 32 times.
4. Check 1st trip DTC.

Is 1st trip DTC detected?

- YES >> Proceed to [EC-1384, "Diagnosis Procedure"](#).
- NO >> INSPECTION END

Diagnosis Procedure

INFOID:000000007187635

1. INSPECTION START

1. Turn ignition switch ON.
2. Erase DTC.
3. Perform DTC Confirmation Procedure.  
See [EC-1384, "DTC Logic"](#).

Is the 1st trip DTC P0605 displayed again?

- YES >> GO TO 2.



# P0605 ECM

[VK56VD FOR USA AND CANADA]

< DTC/CIRCUIT DIAGNOSIS >

NO >> INSPECTION END

**2.**REPLACE ECM

Replace ECM. Refer to [EC-1553, "Removal and Installation"](#).

>> INSPECTION END

A

EC

C

D

E

F

G

H

I

J

K

L

M

N

O

P

< DTC/CIRCUIT DIAGNOSIS >

P0607 ECM

DTC Logic

INFOID:000000007187636

DTC DETECTION LOGIC

| DTC No. | Trouble diagnosis name<br>(Trouble diagnosis content) | DTC detecting condition   | Possible cause |
|---------|---|---|----------------|
| P0607   | ECM<br>(CAN communication bus)                        | When detecting error during the initial diagnosis of CAN controller of ECM. | ECM            |

DTC CONFIRMATION PROCEDURE

1. PERFORM DTC CONFIRMATION PROCEDURE

1. Turn ignition switch ON.
2. Check DTC.

Is DTC detected?

- YES >> Proceed to [EC-1386, "Diagnosis Procedure"](#).
- NO >> INSPECTION END

Diagnosis Procedure

INFOID:000000007187637

1. INSPECTION START

1. Turn ignition switch ON.
2. Erase DTC.
3. Perform DTC Confirmation Procedure.  
See [EC-1386, "DTC Logic"](#).
4. Check DTC.

Is the DTC P0607 displayed again?

- YES >> Replace ECM and perform additional service when replacing ECM. Refer to [EC-1117, "Work Procedure"](#).
- NO >> INSPECTION END

# P0611 ECM PROTECTION

< DTC/CIRCUIT DIAGNOSIS >

[VK56VD FOR USA AND CANADA]

## P0611 ECM PROTECTION

### Description

INFOID:000000007187638

This DTC is detected when the ECM protective function is activated due to an extreme temperature increase in ECM, resulting from severe conditions such as heavy load driving.

### DTC Logic

INFOID:000000007187639

### DTC DETECTION LOGIC

| DTC No. | Trouble diagnosis name | DTC detecting condition                       | Possible cause |
|---------|------------------------|---|----------------|
| P0611   | ECM PROTECTION         | ECM overheat protection control is activated. | ECM overheated |

### DTC CONFIRMATION PROCEDURE

#### 1. PERFORM DTC CONFIRMATION PROCEDURE

This DTC is displayed as protection function history. If no malfunction is detected after the diagnosis, the customer must be informed of the activation of the protection function.

>> Proceed to [EC-1387, "Diagnosis Procedure"](#).

### Diagnosis Procedure

INFOID:000000007187640

#### 1. INSPECTION START

1. Perform DTC confirmation procedure. Refer to [EC-1384, "DTC Logic"](#).
2. Check 1st trip DTC.

#### Is DTC P0605 detected?

- YES >> Proceed to [EC-1384, "Diagnosis Procedure"](#).
- NO >> Explain the customer about the activation of the protection function.

## P062B ECM

### Description

INFOID:000000007187641

This DTC is detected when the ECM-integrated injector driver unit has a malfunction. For injector driver unit, refer to [EC-999, "ECM"](#).

### DTC Logic

INFOID:000000007187642

### DTC DETECTION LOGIC

| DTC No. | Trouble diagnosis name                                    | DTC detecting condition                 | Possible cause   |
|---------|---|---|--|
| P062B   | Internal control module fuel injector control performance | Injector driver unit is malfunctioning. | <ul style="list-style-type: none"> <li>• Harness and connectors (Injector circuit is open or shorted)</li> <li>• Battery power supply</li> <li>• ECM (injector driver unit)</li> </ul> |

### DTC CONFIRMATION PROCEDURE

#### 1. PRECONDITIONING

1. Turn ignition switch OFF and wait at least 10 seconds.
2. Turn ignition switch ON.
3. Turn ignition switch OFF and wait at least 10 seconds.

#### TESTING CONDITION:

Before performing the following procedure, confirm that battery voltage is 11 V or more at idle.

>> GO TO 2.

#### 2. PERFORM DTC CONFIRMATION PROCEDURE

1. Start the engine and keep the engine speed at idle for 30 seconds.
2. Check 1st trip DTC.

#### Is 1st trip DTC detected?

YES >> Proceed to [EC-1388, "Diagnosis Procedure"](#).

NO >> INSPECTION END

### Diagnosis Procedure

INFOID:000000007187643

#### 1. CHECK FUEL INJECTOR

Check fuel injector. Refer to [EC-1517, "Component Function Check"](#).

#### Is inspection result normal?

YES >> GO TO 2.

NO >> Repair or replace error-detected parts.

#### 2. PERFORM DTC CONFIRMATION PROCEDURE

1. Turn ignition switch ON.
2. Erase DTC.
3. Perform DTC confirmation procedure again. Refer to [EC-1388, "DTC Logic"](#).
4. Check 1st trip DTC.

#### Is the DTC P062B displayed again?

YES >> Replace ECM. Refer to [EC-1553, "Removal and Installation"](#).

NO >> INSPECTION END

# P0643 SENSOR POWER SUPPLY

< DTC/CIRCUIT DIAGNOSIS >

[VK56VD FOR USA AND CANADA]

## P0643 SENSOR POWER SUPPLY

### DTC Logic

INFOID:000000007187644

### DTC DETECTION LOGIC

| DTC No. | Trouble diagnosis name<br>(Trouble diagnosis content)    | DTC detecting condition   | Possible cause  |
|---------|--|---|---|
| P0643   | SENSOR POWER/CIRC<br>(Sensor power supply circuit short) | ECM detects that the voltage of power source for sensor is excessively low or high. | <ul style="list-style-type: none"> <li>• Harness or connectors<br/>(Throttle position sensor circuit is shorted.)<br/>[Camshaft position sensor (bank 2) circuit is shorted.]<br/>(Manifold absolute pressure sensor circuit is shorted.)<br/>(Accelerator pedal position sensor 1 circuit is shorted.)</li> <li>• Throttle position sensor</li> <li>• Camshaft position sensor (bank 2)</li> <li>• Manifold absolute pressure sensor</li> <li>• Accelerator pedal position sensor 1</li> </ul> |

### DTC CONFIRMATION PROCEDURE

#### 1. PRECONDITIONING

1. Turn ignition switch OFF and wait at least 10 seconds.
2. Turn ignition switch ON.
3. Turn ignition switch OFF and wait at least 10 seconds.

#### TESTING CONDITION:

Before performing the following procedure, confirm that battery voltage is 8 V or more at idle.

>> GO TO 2.

#### 2. PERFORM DTC CONFIRMATION PROCEDURE

1. Start engine and let it idle for 1 second.
2. Check DTC.

#### Is DTC detected?

YES >> Proceed to [EC-1389, "Diagnosis Procedure"](#).

NO >> INSPECTION END

### Diagnosis Procedure

INFOID:000000007187645

#### 1. CHECK ACCELERATOR PEDAL POSITION SENSOR 1 POWER SUPPLY CIRCUIT

1. Disconnect accelerator pedal position (APP) sensor harness connector.
2. Turn ignition switch ON.
3. Check the voltage between APP sensor harness connector and ground.

| APP sensor       |          | Ground | Voltage (V) |
|------------------|----------|--------|-------------|
| Connector        | Terminal |        |             |
| M9 (Without ICC) | 5        | Ground | Approx. 5   |
| M153 (With ICC)  | 6        |        |             |

#### Is the inspection result normal?

YES >> GO TO 6.

NO >> GO TO 2.

#### 2. CHECK SENSOR POWER SUPPLY CIRCUIT

Check harness for short to power and short to ground, between the following terminals.

# P0643 SENSOR POWER SUPPLY

< DTC/CIRCUIT DIAGNOSIS >

[VK56VD FOR USA AND CANADA]

| ECM       |          | Sensor                            |           |          |
|-----------|----------|-----------------------------------|-----------|----------|
| Connector | Terminal | Name                              | Connector | Terminal |
| F111      | 81       | Throttle position sensor (bank 1) | F66       | 2        |
|           | 82       | Throttle position sensor (bank 2) | F64       | 2        |
|           | 83       | Camshaft position sensor (bank 2) | F83       | 1        |
|           | 85       | Manifold absolute pressure sensor | F19       | 1        |
| M160      | 5        | APP sensor 1 (Without ICC)        | M9        | 5        |
|           | 6        | APP sensor 1 (With ICC)           | M153      | 6        |

Is the inspection result normal?

YES >> GO TO 3.

NO >> Repair short to ground or short to power in harness or connectors.

## 3.CHECK COMPONENTS

Check the following.

- Camshaft position sensor (bank 2) (Refer to [EC-1312, "Component Inspection \(Camshaft Position Sensor\)"](#).)
- Manifold absolute pressure sensor (Refer to [EC-1206, "Component Inspection \(MAP Sensor\)"](#).)

Is the inspection result normal?

YES >> GO TO 4.

NO >> Replace malfunctioning component.

## 4.CHECK THROTTLE POSITION SENSOR

Refer to [EC-1295, "Component Inspection \(Throttle Position Sensor\)"](#).

Is the inspection result normal?

YES >> GO TO 8.

NO >> GO TO 5.

## 5.REPLACE ELECTRIC THROTTLE CONTROL ACTUATOR

Replace electric throttle control actuator. Refer to [EM-191, "Removal and Installation"](#).

>> INSPECTION END

## 6.CHECK ACCELERATOR PEDAL POSITION SENSOR

Refer to [EC-1489, "Component Inspection \(Accelerator Pedal Position Sensor\)"](#).

Is the inspection result normal?

YES >> GO TO 8.

NO >> GO TO 7.

## 7.REPLACE ACCELERATOR PEDAL ASSEMBLY

Replace accelerator pedal assembly.

Refer to [ACC-3, "MODELS WITHOUT DISTANCE CONTROL ASSIST SYSTEM : Removal and Installation"](#) (Without distance control assist system).

Refer to [ACC-4, "MODELS WITH DISTANCE CONTROL ASSIST SYSTEM : Removal and Installation"](#) (With distance control assist system).

>> INSPECTION END

## 8.CHECK INTERMITTENT INCIDENT

Refer to [GI-44, "Intermittent Incident"](#).

>> INSPECTION END

# P0850 PNP SWITCH

< DTC/CIRCUIT DIAGNOSIS >

[VK56VD FOR USA AND CANADA]

## P0850 PNP SWITCH

### Description

INFOID:000000007187646

When the selector lever position is P or N, park/neutral position (PNP) signal is sent to ECM from TCM.

### DTC Logic

INFOID:000000007187647

### DTC DETECTION LOGIC

| DTC No. | Trouble diagnosis name<br>(Trouble diagnosis content) | DTC detecting condition  | Possible cause  |
|---------|---|--|---|
| P0850   | P-N POS SW/CIRCUIT<br>(Park/neutral position switch)  | The signal of the park/neutral position (PNP) signal does not change during driving after the engine is started. | <ul style="list-style-type: none"> <li>Harness or connectors<br/>[The park/neutral position (PNP) signal circuit is open or shorted.]</li> <li>TCM</li> </ul> |

### DTC CONFIRMATION PROCEDURE

#### 1.INSPECTION START

Will CONSULT be used?

Will CONSULT be used?

YES >> GO TO 2.

NO >> GO TO 5.

#### 2.PRECONDITIONING

If DTC Confirmation Procedure has been previously conducted, always perform the following procedure before conducting the next test.

- Turn ignition switch OFF and wait at least 10 seconds.
- Turn ignition switch ON.
- Turn ignition switch OFF and wait at least 10 seconds.

>> GO TO 3.

#### 3.CHECK PNP SIGNAL

Ⓜ WITH CONSULT

- Turn ignition switch ON.
- Select "P/N POSI SW" in "DATA MONITOR" mode with CONSULT. Then check the "P/N POSI SW" signal under the following conditions.

| Position (Selector lever) | Known-good signal |
|---------------------------|-------------------|
| N or P position           | ON                |
| Except above position     | OFF               |

Is the inspection result normal?

YES >> GO TO 4.

NO >> Proceed to [EC-1392, "Diagnosis Procedure"](#).

#### 4.PERFORM DTC CONFIRMATION PROCEDURE

- Select "DATA MONITOR" mode with CONSULT.
- Start engine and warm it up to normal operating temperature.
- Maintain the following conditions for at least 50 consecutive seconds.

**CAUTION:**

**Always drive vehicle at a safe speed.**

|               |                        |
|---------------|------------------------|
| ENG SPEED     | 1,000 - 6,375 rpm      |
| COOLAN TEMP/S | More than 60°C (140°F) |

# P0850 PNP SWITCH

[VK56VD FOR USA AND CANADA]

## < DTC/CIRCUIT DIAGNOSIS >

|                |                            |
|----------------|----------------------------|
| B/FUEL SCHDL   | 2.0 - 31.8 msec            |
| VHCL SPEED SE  | More than 64 km/h (40 mph) |
| Selector lever | Suitable position          |

### 4. Check 1st trip DTC.

#### Is 1st trip DTC detected?

YES >> Proceed to [EC-1392, "Diagnosis Procedure"](#).

NO >> INSPECTION END

## 5.PERFORM COMPONENT FUNCTION CHECK

### WITH GST

Perform Component Function Check. Refer to [EC-1392, "Component Function Check"](#).

#### **NOTE:**

Use Component Function Check to check the overall function of the park/neutral position (PNP) signal circuit. During this check, a 1st trip DTC might not be confirmed.

#### Is the inspection result normal?

YES >> INSPECTION END

NO >> Proceed to [EC-1392, "Diagnosis Procedure"](#).

## Component Function Check

INFOID:000000007187648

## 1.PERFORM COMPONENT FUNCTION CHECK

### With GST

1. Turn ignition switch ON.
2. Check the voltage between ECM harness connector terminals under the following conditions.

| ECM       |          |          | Condition      | Voltage (V)           |                 |
|-----------|----------|----------|----------------|-----------------------|-----------------|
| Connector | +        | -        |                |                       |                 |
|           | Terminal | Terminal |                |                       |                 |
| F110      | 11       | 175      | Selector lever | P or N position       | Battery voltage |
|           |          |          |                | Except above position | Approx. 0 V     |

#### Is the inspection result normal?

YES >> INSPECTION END

NO >> Proceed to [EC-1392, "Diagnosis Procedure"](#).

## Diagnosis Procedure

INFOID:000000007187649

## 1.CHECK DTC WITH TCM

Refer to [TM-60, "CONSULT Function"](#).

#### Is the inspection result normal?

YES >> GO TO 2.

NO >> Repair or replace malfunctioning part.

## 2.CHECK STARTING SYSTEM

Turn ignition switch OFF, then turn it to START.

#### Does starter motor operate?

YES >> GO TO 3.

NO >> Check DTC with BCM. Refer to [BCS-15, "COMMON ITEM : CONSULT Function \(BCM - COMMON ITEM\)"](#).

## 3.CHECK PNP SIGNAL CIRCUIT FOR OPEN AND SHORT

1. Turn ignition switch OFF.
2. Disconnect A/T assembly harness connector.
3. Disconnect ECM harness connector.
4. Check the continuity between A/T assembly harness connector and ECM harness connector.



# P0850 PNP SWITCH

< DTC/CIRCUIT DIAGNOSIS >

[VK56VD FOR USA AND CANADA]

| A/T assembly |          | ECM       |          | Continuity |
|--------------|----------|-----------|----------|------------|
| Connector    | Terminal | Connector | Terminal |            |
| F301         | 9        | F110      | 11       | Existed    |

5. Also check harness for short to ground and short to power.

Is the inspection result normal?

- YES >> GO TO 5.
- NO >> GO TO 4.

## 4. DETECT MALFUNCTIONING PART

Check the following.

- Harness for open or short between A/T assembly and ECM
- Loose or poor connection for each connector and harness

>> Repair open circuit, short to ground or short to power in harness or connectors.

## 5. CHECK INTERMITTENT INCIDENT

Refer to [GI-44, "Intermittent Incident"](#).

>> INSPECTION END

A

EC

C

D

E

F

G

H

I

J

K

L

M

N

O

P

# P100A, P100B VVEL SYSTEM

< DTC/CIRCUIT DIAGNOSIS >

[VK56VD FOR USA AND CANADA]

## P100A, P100B VVEL SYSTEM

### DTC Logic

INFOID:000000007187650

#### DTC DETECTION LOGIC

##### NOTE:

If DTC P100A or P100B is displayed with DTC P1090 or P1093, first perform the trouble diagnosis for DTC P1090 or P1093. Refer to [EC-1408, "DTC Logic"](#).

| DTC No. | Trouble diagnosis name<br>(Trouble diagnosis content)     | DTC detecting condition                  | Possible cause  |
|---------|---|--|---|
| P100A   | VVEL SYSTEM-B1<br>[VVEL response malfunction<br>(bank 1)] | Actual event response to target is poor. | <ul style="list-style-type: none"><li>• Harness or connectors<br/>(VVEL actuator motor circuit is open or shorted.)</li><li>• VVEL actuator motor</li><li>• VVEL actuator sub assembly</li><li>• VVEL ladder assembly</li><li>• VVEL control module</li></ul> |
| P100B   | VVEL SYSTEM-B2<br>[VVEL response malfunction<br>(bank 2)] |  |   |

#### DTC CONFIRMATION PROCEDURE

##### 1. PRECONDITIONING

1. Turn ignition switch OFF and wait at least 10 seconds.
2. Turn ignition switch ON.
3. Turn ignition switch OFF and wait at least 10 seconds.

##### TESTING CONDITION:

Before performing the following procedure, confirm that battery voltage is 10 V or more at idle.

>> GO TO 2.

##### 2. PERFORM DTC CONFIRMATION PROCEDURE

1. Start engine.
2. Depress the accelerator pedal rapidly half or more under no load conditions, and then release it.
3. Wait at idle for 5 seconds or more.
4. Repeat steps 2 to 3 for three times.
5. Check 1st trip DTC.

##### Is DTC detected?

- YES >> Proceed to [EC-1394, "Diagnosis Procedure"](#).  
NO >> INSPECTION END

#### Diagnosis Procedure

INFOID:000000007187651

##### 1. VVEL ACTUATOR MOTOR OUTPUT SIGNAL CIRCUIT FOR OPEN AND SHORT

1. Disconnect VVEL control module harness connector.
2. Disconnect VVEL actuator motor harness connector.
3. Check the continuity between VVEL control module harness connector and VVEL actuator motor harness connector.

# P100A, P100B VVEL SYSTEM

< DTC/CIRCUIT DIAGNOSIS >

[VK56VD FOR USA AND CANADA]

| DTC No. | VVEL control module |           |          | VVEL actuator motor |          | Continuity  |             |
|---------|---------------------|-----------|----------|---------------------|----------|-------------|-------------|
|         | Bank                | Connector | Terminal | Connector           | Terminal |             |             |
| P100A   | 1                   | E15       | 12       | F73                 | 1        | Existed     |             |
|         |                     |           |          |                     | 2        | Not existed |             |
|         |                     |           | 25       |                     | 1        | Not existed |             |
|         |                     |           |          |                     | 2        | Existed     |             |
| P100B   | 2                   |           |          | 2                   | F71      | 1           | Existed     |
|         |                     |           |          |                     |          | 2           | Not existed |
|         |                     |           |          | 15                  |          | 1           | Not existed |
|         |                     |           |          |                     |          | 2           | Existed     |

4. Also check harness for short to ground and power.

Is the inspection result normal?

YES >> GO TO 3.

NO >> GO TO 2.

## 2. DETECT MALFUNCTIONING PART

Check the following.

- Harness for open or short between VVEL actuator motor and VVEL control module
- Loose or poor connection for each connector and harness

>> Repair open circuit, short to ground or short to power in harness or connectors.

## 3. CHECK VVEL ACTUATOR MOTOR

Refer to [EC-1396. "Component Inspection \(VVEL ACTUATOR MOTOR\)"](#).

Is the inspection result normal?

YES >> GO TO 5.

NO >> GO TO 4.

## 4. REPLACE VVEL ACTUATOR SUB ASSEMBLY

Replace VVEL actuator sub assembly. Refer to [EM-246. "Exploded View"](#).

>> INSPECTION END

## 5. CHECK INTERMITTENT INCIDENT

Refer to [GI-44. "Intermittent Incident"](#).

Is the inspection result normal?

YES >> GO TO 6.

NO >> Repair or replace.

## 6. REPLACE VVEL CONTROL MODULE

Replace VVEL control module. Refer to [EC-1554. "Removal and Installation"](#).

>> GO TO 7.

## 7. PERFORM DTC CONFIRMATION PROCEDURE

1. Turn ignition switch ON.
2. Erase 1st trip DTC.
3. Perform DTC Confirmation Procedure.  
See [EC-1394. "DTC Logic"](#).

Is the DTC P100A or P100B displayed again?

YES >> GO TO 8.

NO >> INSPECTION END

# P100A, P100B VVEL SYSTEM

< DTC/CIRCUIT DIAGNOSIS >

[VK56VD FOR USA AND CANADA]

## 8. CHECK VVEL ACTUATOR SUB ASSEMBLY

Refer to [EC-1396, "Component Inspection \(VVEL ACTUATOR SUB ASSEMBLY\)"](#).

Is the inspection result normal?

YES >> GO TO 10.

NO >> GO TO 9.

## 9. REPLACE VVEL ACTUATOR SUB ASSEMBLY

Replace VVEL actuator sub assembly. Refer to [EM-246, "Exploded View"](#).

>> INSPECTION END

## 10. CHECK VVEL LADDER ASSEMBLY

Refer to [EM-246, "Exploded View"](#).

Is the inspection result normal?

YES >> GO TO 12.

NO >> GO TO 11.

## 11. REPLACE CYLINDER HEAD, VVEL LADDER ASSEMBLY AND VVEL ACTUATOR SUB ASSEMBLY

Replace cylinder head, VVEL ladder assembly and VVEL actuator sub assembly.

Refer to [EM-264, "Exploded View"](#) (Cylinder head).

Refer to [EM-246, "Exploded View"](#) (VVEL ladder assembly and VVEL actuator sub assembly)

>> INSPECTION END

## 12. CHECK INTERMITTENT INCIDENT

Refer to [GI-44, "Intermittent Incident"](#).

>> INSPECTION END

## Component Inspection (VVEL ACTUATOR MOTOR)

INFOID:000000007187652

### 1. CHECK VVEL ACTUATOR MOTOR

1. Turn ignition switch OFF.
2. Disconnect VVEL actuator motor harness connector.
3. Check resistance between VVEL actuator motor terminals as per the following.

| VVEL actuator motor<br>Terminal | Resistance          |
|---------------------------------|---------------------|
| 1 and 2                         | 16 $\Omega$ or less |

Is the inspection result normal?

YES >> INSPECTION END

NO >> GO TO 2.

### 2. REPLACE VVEL ACTUATOR SUB ASSEMBLY

Replace VVEL actuator sub assembly. Refer to [EM-246, "Exploded View"](#).

>> INSPECTION END

## Component Inspection (VVEL ACTUATOR SUB ASSEMBLY)

INFOID:000000007187653

### 1. CHECK VVEL ACTUATOR SUB ASSEMBLY

1. Turn ignition switch OFF.
2. Remove VVEL actuator sub assembly. Refer to [EM-246, "Exploded View"](#).
3. Turn the ball screw shaft to check that it works smoothly.

# P100A, P100B VVEL SYSTEM

[VK56VD FOR USA AND CANADA]

< DTC/CIRCUIT DIAGNOSIS >

Is the inspection result normal?

YES >> INSPECTION END

NO >> GO TO 2.

## 2.REPLACE VVEL ACTUATOR SUB ASSEMBLY

Replace VVEL actuator sub assembly. Refer to [EM-246. "Exploded View"](#).

>> INSPECTION END

A

EC

C

D

E

F

G

H

I

J

K

L

M

N

O

P

# P1078, P1084 EVT CONTROL POSITION SENSOR

< DTC/CIRCUIT DIAGNOSIS >

[VK56VD FOR USA AND CANADA]

## P1078, P1084 EVT CONTROL POSITION SENSOR

### DTC Logic

INFOID:000000007187654

### DTC DETECTION LOGIC

| DTC No. | Trouble diagnosis name<br>(Trouble diagnosis content)                                  | DTC detecting condition  | Possible cause   |
|---------|--|--|--|
| P1078   | EXH TIM SEN/CIRC-B1<br>[Exhaust valve timing control position sensor (bank 1) circuit] | An excessively high or low voltage from the sensor is sent to ECM. | <ul style="list-style-type: none"><li>• Harness or connectors<br/>[Exhaust valve timing control position sensor (bank 1) circuit is open or shorted]</li><li>• Exhaust valve timing control position sensor (bank 1)</li><li>• Crankshaft position sensor</li><li>• Camshaft position sensor (bank 1)</li><li>• Accumulation of debris to the signal pick-up portion of the camshaft</li></ul> |
| P1084   | EXH TIM SEN/CIRC-B2<br>[Exhaust valve timing control position sensor (bank 2) circuit] |  | <ul style="list-style-type: none"><li>• Harness or connectors<br/>[Exhaust valve timing control position sensor (bank 2) circuit is open or shorted]</li><li>• Exhaust valve timing control position sensor (bank 2)</li><li>• Crankshaft position sensor</li><li>• Camshaft position sensor (bank 2)</li><li>• Accumulation of debris to the signal pick-up portion of the camshaft</li></ul> |

### DTC CONFIRMATION PROCEDURE

#### 1. PRECONDITIONING

If DTC Confirmation Procedure has been previously conducted, always perform the following procedure before conducting the next test.

1. Turn ignition switch OFF and wait at least 10 seconds.
2. Turn ignition switch ON.
3. Turn ignition switch OFF and wait at least 10 seconds.

>> GO TO 2.

#### 2. PERFORM DTC CONFIRMATION PROCEDURE

1. Start engine and let it idle for 10 seconds.
2. Check 1st trip DTC.

Is 1st trip DTC detected?

- YES >> Proceed to [EC-1398, "Diagnosis Procedure"](#).  
NO >> INSPECTION END

### Diagnosis Procedure

INFOID:000000007187655

#### 1. CHECK EXHAUST VALVE TIMING CONTROL POSITION SENSOR POWER SUPPLY CIRCUIT-I

1. Disconnect exhaust valve timing (EVT) control position sensor harness connector.
2. Turn ignition switch ON.
3. Check the voltage between exhaust valve timing control position sensor harness connector and ground.

| DTC   | EVT control position sensor |           |          | Ground | Voltage (V) |
|-------|-----------------------------|-----------|----------|--------|-------------|
|       | Bank                        | Connector | Terminal |        |             |
| P1078 | 1                           | F59       | 1        | Ground | Approx. 5   |
| P1084 | 2                           | F63       | 1        |        |             |

Is the inspection result normal?

- YES >> GO TO 2.  
NO >> Repair open circuit, short to ground in harness or connectors.

# P1078, P1084 EVT CONTROL POSITION SENSOR

< DTC/CIRCUIT DIAGNOSIS >

[VK56VD FOR USA AND CANADA]

## 2. CHECK EVT CONTROL POSITION SENSOR GROUND CIRCUIT FOR OPEN AND SHORT

1. Turn ignition switch OFF.
2. Disconnect ECM harness connector.
3. Check the continuity between EVT control position sensor harness connector and ECM harness connector.

| DTC   | EVT control position sensor |           |          | ECM       |          | Continuity |
|-------|-----------------------------|-----------|----------|-----------|----------|------------|
|       | Bank                        | Connector | Terminal | Connector | Terminal |            |
| P1078 | 1                           | F59       | 2        | F111      | 68       | Existed    |
| P1084 | 2                           | F63       | 2        | F111      | 99       |            |

4. Also check harness for short to power.

Is the inspection result normal?

YES >> GO TO 3.

NO >> Repair open circuit, short to power in harness or connectors.

## 3. CHECK EVT CONTROL POSITION SENSOR INPUT SIGNAL CIRCUIT FOR OPEN AND SHORT

1. Check the continuity between EVT control position sensor harness connector and ECM harness connector.

| DTC   | EVT control position sensor |           |          | ECM       |          | Continuity |
|-------|-----------------------------|-----------|----------|-----------|----------|------------|
|       | Bank                        | Connector | Terminal | Connector | Terminal |            |
| P1078 | 1                           | F59       | 3        | F111      | 75       | Existed    |
| P1084 | 2                           | F63       | 3        |           | 93       |            |

2. Also check harness for short to ground and short to power.

Is the inspection result normal?

YES >> GO TO 4.

NO >> Repair open circuit, short to ground or short to power in harness or connectors.

## 4. CHECK EXHAUST VALVE TIMING CONTROL POSITION SENSOR

Refer to [EC-1400, "Component Inspection \(Exhaust Valve Timing Control Position Sensor\)"](#).

Is the inspection result normal?

YES >> GO TO 5.

NO >> Replace malfunctioning exhaust valve timing control position sensor. Refer to [EM-231, "Exploded View"](#).

## 5. CHECK CRANKSHAFT POSITION SENSOR

Refer to [EC-1307, "Component Inspection \(Crankshaft Position Sensor\)"](#).

Is the inspection result normal?

YES >> GO TO 6.

NO >> Replace crankshaft position sensor. Refer to [EM-226, "Exploded View" \(2WD\)](#) or [EM-204, "2WD : Exploded View" \(AWD\)](#).

## 6. CHECK CAMSHAFT POSITION SENSOR

Refer to [EC-1312, "Component Inspection \(Camshaft Position Sensor\)"](#).

Is the inspection result normal?

YES >> GO TO 7.

NO >> Replace malfunctioning camshaft position sensor. Refer to [EM-231, "Exploded View"](#).

## 7. CHECK CAMSHAFT SPROCKET (SIGNAL PLATE)

Check the following.

# P1078, P1084 EVT CONTROL POSITION SENSOR

[VK56VD FOR USA AND CANADA]

## < DTC/CIRCUIT DIAGNOSIS >

- Accumulation of debris to the signal plate of camshaft sprocket (EXH)
- Chipping signal plate of camshaft sprocket (EXH)

### Is the inspection result normal?

YES >> GO TO 8.

NO >> Remove debris and clean the signal plate of camshaft sprocket (EXH) or replace camshaft sprocket (EXH). Refer to [EM-231, "Exploded View"](#).

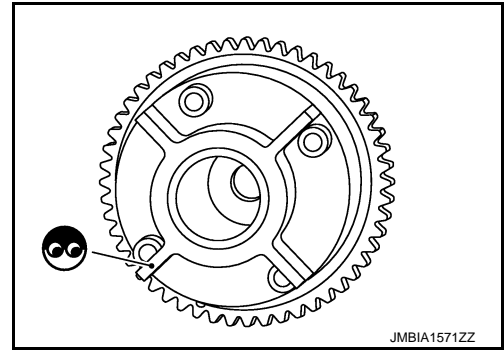

## 8. CHECK INTERMITTENT INCIDENT

Refer to [GI-44, "Intermittent Incident"](#).

>> INSPECTION END

## Component Inspection (Exhaust Valve Timing Control Position Sensor)

INFOID:000000007187656

### 1. EXHAUST VALVE TIMING CONTROL POSITION SENSOR-I

1. Turn ignition switch OFF.
2. Disconnect exhaust valve timing control position sensor harness connector.
3. Loosen the fixing bolt of the sensor.
4. Remove the sensor. Refer to [EM-231, "Exploded View"](#).
5. Visually check the sensor for chipping.

### Is the inspection result normal?

YES >> GO TO 2.

NO >> Replace malfunctioning exhaust valve timing control position sensor. Refer to [EM-231, "Exploded View"](#).

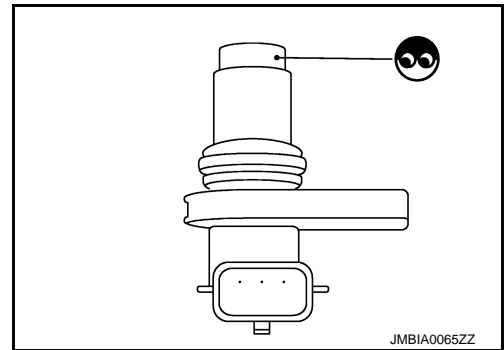

### 2. EXHAUST VALVE TIMING CONTROL POSITION SENSOR-II

Check resistance exhaust valve timing control position sensor terminals as shown below.

| Terminals     | Resistance                                     |
|---------------|--|
| 1 (+) - 2 (-) | Except 0 or $\infty$ $\Omega$ [at 25°C (77°F)] |
| 1 (+) - 3 (-) |  |
| 2 (+) - 3 (-) |  |

### Is the inspection result normal?

YES >> INSPECTION END

NO >> Replace malfunctioning exhaust valve timing control position sensor. Refer to [EM-231, "Exploded View"](#).



# P1087, P1088 VVEL SYSTEM

< DTC/CIRCUIT DIAGNOSIS >

[VK56VD FOR USA AND CANADA]

## P1087, P1088 VVEL SYSTEM

### DTC Logic

INFOID:000000007187657

### DTC DETECTION LOGIC

**NOTE:**

If DTC P1087 or P1088 is displayed with DTC P1090 or P1093.

Perform the trouble diagnosis for DTC P1090 or P1093. Refer to [EC-1405, "DTC Logic"](#).

| DTC No. | Trouble diagnosis name<br>(Trouble diagnosis content)              | DTC detecting condition                                   | Possible cause  |
|---------|--|---|---|
| P1087   | VVEL SYSTEM-B1<br>[VVEL small event angle malfunction<br>(bank 1)] | The event angle of VVEL control<br>shaft is always small. | <ul style="list-style-type: none"><li>• Harness or connectors<br/>(VVEL actuator motor circuit is<br/>open or shorted.)</li><li>• VVEL actuator motor</li><li>• VVEL actuator sub assembly</li><li>• VVEL ladder assembly</li><li>• VVEL control module</li></ul> |
| P1088   | VVEL SYSTEM-B2<br>[VVEL small event angle malfunction<br>(bank 2)] |   |   |

### Diagnosis Procedure

INFOID:000000007187658

If DTC P1087 or P1088 is displayed with DTC P1090 or P1093.

Perform the trouble diagnosis for DTC P1090 or P1093. Refer to [EC-1405, "DTC Logic"](#).

# P1089, P1092 VVEL CONTROL SHAFT POSITION SENSOR

< DTC/CIRCUIT DIAGNOSIS >

[VK56VD FOR USA AND CANADA]

## P1089, P1092 VVEL CONTROL SHAFT POSITION SENSOR

### DTC Logic

INFOID:000000007187659

#### DTC DETECTION LOGIC

##### NOTE:

If DTC P1089 or P1092 is displayed with DTC P1608, first perform the trouble diagnosis for DTC P1608. Refer to [EC-1479, "DTC Logic"](#).

| DTC No. | Trouble diagnosis name<br>(Trouble diagnosis content)                         | DTC detecting condition  | Possible cause  |
|---------|---|--|---|
| P1089   | VVEL POS SEN/CIRC-B1<br>[VVEL control shaft position sensor (bank 1) circuit] | <ul style="list-style-type: none"><li>An excessively low voltage from the sensor is sent to VVEL control module.</li><li>An excessively high voltage from the sensor is sent to VVEL control module.</li><li>Rationally incorrect voltage is sent to VVEL control module compared with the signals from VVEL control shaft position sensor 1 and VVEL control shaft position sensor 2.</li></ul> | <ul style="list-style-type: none"><li>Harness or connectors (VVEL control shaft position sensor circuit is open or shorted.)</li><li>VVEL control shaft position sensor</li><li>VVEL control module</li></ul> |
| P1092   | VVEL POS SEN/CIRC-B2<br>[VVEL control shaft position sensor (bank 2) circuit] |  |   |

#### DTC CONFIRMATION PROCEDURE

##### 1. PRECONDITIONING

- Turn ignition switch OFF and wait at least 10 seconds.
- Turn ignition switch ON.
- Turn ignition switch OFF and wait at least 10 seconds.

##### TESTING CONDITION:

Before performing the following procedure, confirm that battery voltage is 10 V or more at idle.

>> GO TO 2.

##### 2. PERFORM DTC CONFIRMATION PROCEDURE

- Start engine and let it idle for 1 second.
- Check DTC.

##### Is DTC detected?

- YES >> Proceed to [EC-1402, "Diagnosis Procedure"](#).  
NO >> INSPECTION END

#### Diagnosis Procedure

INFOID:000000007187660

##### 1. VVEL CONTROL SHAFT POSITION SENSOR POWER SUPPLY CIRCUIT

- Disconnect VVEL control shaft position sensor harness connector.
- Turn ignition switch ON.
- Check the voltage between VVEL control shaft position sensor harness connector and ground.

| DTC No. | VVEL control shaft position sensor |           |          | Ground | Voltage (V) |
|---------|------------------------------------|-----------|----------|--------|-------------|
|         | Bank                               | Connector | Terminal |        |             |
| P1089   | 1                                  | F72       | 3        | Ground | Approx. 5   |
|         |                                    |           | 6        |        |             |
| P1092   | 2                                  | F70       | 3        |        |             |
|         |                                    |           | 6        |        |             |

##### Is the inspection result normal?

- YES >> GO TO 3.  
NO >> GO TO 2.

##### 2. DETECT MALFUNCTIONING PART

Check the following.

# P1089, P1092 VVEL CONTROL SHAFT POSITION SENSOR

[VK56VD FOR USA AND CANADA]

## < DTC/CIRCUIT DIAGNOSIS >

- Harness for open or short between VVEL control shaft position sensor and VVEL control module
- Loose or poor connection for each connector and harness

>> Repair open circuit, short to ground or short to power in harness or connectors.

### 3. CHECK VVEL CONTROL SHAFT POSITION SENSOR GROUND CIRCUIT FOR OPEN AND SHORT

1. Turn ignition switch OFF.
2. Disconnect VVEL control module harness connector.
3. Check the continuity between VVEL control shaft position sensor harness connector and VVEL control module harness connector.

| DTC No. | VVEL control shaft position sensor |           |          | VVEL control module |          | Continuity |
|---------|------------------------------------|-----------|----------|---------------------|----------|------------|
|         | Bank                               | Connector | Terminal | Connector           | Terminal |            |
| P1089   | 1                                  | F72       | 2        | E15                 | 6        | Existed    |
|         |                                    |           | 5        |                     | 19       |            |
| P1092   | 2                                  | F70       | 2        |                     | 4        |            |
|         |                                    |           | 5        |                     | 17       |            |

4. Also check harness for short to power.

Is the inspection result normal?

YES >> GO TO 5.

NO >> GO TO 4.

### 4. DETECT MALFUNCTIONING PART

Check the following.

- Harness for open or short between VVEL control shaft position sensor and VVEL control module
- Loose or poor connection for each connector and harness

>> Repair open circuit, short to ground or short to power in harness or connectors.

### 5. VVEL CONTROL SHAFT POSITION SENSOR INPUT SIGNAL CIRCUIT FOR OPEN AND SHORT

1. Check the continuity between VVEL control shaft position sensor harness connector and VVEL control module harness connector.

| DTC No. | VVEL control shaft position sensor |           |          | VVEL control module |          | Continuity |
|---------|------------------------------------|-----------|----------|---------------------|----------|------------|
|         | Bank                               | Connector | Terminal | Connector           | Terminal |            |
| P1089   | 1                                  | F72       | 1        | E15                 | 3        | Existed    |
|         |                                    |           | 4        |                     | 16       |            |
| P1092   | 2                                  | F70       | 1        |                     | 5        |            |
|         |                                    |           | 4        |                     | 18       |            |

2. Also check harness for short to ground and power.

Is the inspection result normal?

YES >> GO TO 7.

NO >> GO TO 6.

### 6. DETECT MALFUNCTIONING PART

Check the following.

- Harness for open or short between VVEL control shaft position sensor and VVEL control module
- Loose or poor connection for each connector and harness

>> Repair open circuit, short to ground or short to power in harness or connectors.

### 7. CHECK INTERMITTENT INCIDENT

Refer to [GI-44, "Intermittent Incident"](#).

## P1089, P1092 VVEL CONTROL SHAFT POSITION SENSOR

[VK56VD FOR USA AND CANADA]

< DTC/CIRCUIT DIAGNOSIS >

---

Is the inspection result normal?

YES >> GO TO 8.

NO >> Repair or replace.

### 8.REPLACE VVEL CONTROL MODULE

---

Replace VVEL control module. Refer to [EC-1554, "Removal and Installation"](#).

>> GO TO 9.

### 9.PERFORM DTC CONFIRMATION PROCEDURE

- 
1. Turn ignition switch ON.
  2. Erase DTC.
  3. Perform DTC Confirmation Procedure.  
See [EC-1402, "DTC Logic"](#).

Is the DTC P1089 or P1092 displayed again?

YES >> GO TO 10.

NO >> INSPECTION END

### 10.REPLACE VVEL ACTUATOR SUB ASSEMBLY

---

Replace VVEL actuator sub assembly. Refer to [EM-246, "Exploded View"](#).

>> INSPECTION END

# P1090, P1093 VVEL ACTUATOR MOTOR

< DTC/CIRCUIT DIAGNOSIS >

[VK56VD FOR USA AND CANADA]

## P1090, P1093 VVEL ACTUATOR MOTOR

### DTC Logic

INFOID:000000007187661

### DTC DETECTION LOGIC

**NOTE:**

If DTC P1090 or P1093 is displayed with DTC P1091, first perform the trouble diagnosis for DTC P1091. Refer to [EC-1408. "DTC Logic"](#).

| DTC No. | Trouble diagnosis name<br>(Trouble diagnosis content)     | DTC detecting condition   | Possible cause  |
|---------|---|---|---|
| P1090   | VVEL ACTR MOT-B1<br>[VVEL system performance<br>(bank 1)] | <ul style="list-style-type: none"> <li>Event angle difference between the actual and the target is detected.</li> <li>Abnormal current is sent to VVEL actuator motor.</li> </ul> | <ul style="list-style-type: none"> <li>Harness or connectors (VVEL actuator motor circuit is open or shorted.)</li> <li>VVEL actuator motor</li> <li>VVEL actuator sub assembly</li> <li>VVEL ladder assembly</li> <li>VVEL control module</li> </ul> |
| P1093   | VVEL ACTR MOT-B2<br>[VVEL system performance<br>(bank 2)] |   |   |

### DTC CONFIRMATION PROCEDURE

#### 1. PRECONDITIONING

- Turn ignition switch OFF and wait at least 10 seconds.
- Turn ignition switch ON.
- Turn ignition switch OFF and wait at least 10 seconds.

**TESTING CONDITION:**

Before performing the following procedure, confirm that battery voltage is 10 V or more at idle.

>> GO TO 2.

#### 2. PERFORM DTC CONFIRMATION PROCEDURE

- Start engine and let it idle for 10 second.
- Keep the engine speed at approximately 3,500 rpm for at least 10 seconds under no load.
- Check DTC.

Is DTC detected?

- YES >> Proceed to [EC-1405. "Diagnosis Procedure"](#).  
 NO >> INSPECTION END

### Diagnosis Procedure

INFOID:000000007187662

#### 1. VVEL ACTUATOR MOTOR OUTPUT SIGNAL CIRCUIT FOR OPEN AND SHORT

- Disconnect VVEL control module harness connector.
- Disconnect VVEL actuator motor harness connector.
- Check the continuity between VVEL control module harness connector and VVEL actuator motor harness connector.

| DTC No. | VVEL control module |           |          | VVEL actuator motor |          | Continuity  |
|---------|---------------------|-----------|----------|---------------------|----------|-------------|
|         | Bank                | Connector | Terminal | Connector           | Terminal |             |
| P1090   | 1                   | E15       | 12       | F73                 | 1        | Existed     |
|         |                     |           |          |                     | 2        | Not existed |
|         |                     |           | 25       |                     | 1        | Not existed |
|         |                     |           |          |                     | 2        | Existed     |
| P1093   | 2                   |           | 2        | F71                 | 1        | Existed     |
|         |                     |           |          |                     | 2        | Not existed |
|         |                     |           | 15       |                     | 1        | Not existed |
|         |                     |           |          |                     | 2        | Existed     |

# P1090, P1093 VVEL ACTUATOR MOTOR

[VK56VD FOR USA AND CANADA]

< DTC/CIRCUIT DIAGNOSIS >

4. Also check harness for short to ground and power.

Is the inspection result normal?

YES >> GO TO 3.

NO >> GO TO 2.

## 2.DETECT MALFUNCTIONING PART

Check the following.

- Harness for open or short between VVEL actuator motor and VVEL control module
- Loose or poor connection for each connector and harness

>> Repair open circuit, short to ground or short to power in harness or connectors.

## 3.CHECK VVEL ACTUATOR MOTOR

Refer to [EC-1407, "Component Inspection \(VVEL ACTUATOR MOTOR\)"](#).

Is the inspection result normal?

YES >> GO TO 5.

NO >> GO TO 4.

## 4.REPLACE VVEL ACTUATOR SUB ASSEMBLY

Replace VVEL actuator sub assembly. Refer to [EM-246, "Exploded View"](#).

>> INSPECTION END

## 5.CHECK INTERMITTENT INCIDENT

Refer to [GI-44, "Intermittent Incident"](#).

Is the inspection result normal?

YES >> GO TO 6.

NO >> Repair or replace.

## 6.REPLACE VVEL CONTROL MODULE

Replace VVEL control module. Refer to [EC-1554, "Removal and Installation"](#).

>> GO TO 7.

## 7.PERFORM DTC CONFIRMATION PROCEDURE

1. Turn ignition switch ON.
2. Erase DTC.
3. Perform DTC Confirmation Procedure.  
See [EC-1405, "DTC Logic"](#).

Is the DTC P1090 or P1093 displayed again?

YES >> GO TO 8.

NO >> INSPECTION END

## 8.CHECK VVEL ACTUATOR SUB ASSEMBLY

Refer to [EC-1407, "Component Inspection \(VVEL ACTUATOR SUB ASSEMBLY\)"](#).

Is the inspection result normal?

YES >> GO TO 10.

NO >> GO TO 9.

## 9.REPLACE VVEL ACTUATOR SUB ASSEMBLY

Replace VVEL actuator sub assembly. Refer to [EM-246, "Exploded View"](#).

>> INSPECTION END

## 10.CHECK VVEL LADDER ASSEMBLY

Refer to [EM-246, "Exploded View"](#).

# P1090, P1093 VVEL ACTUATOR MOTOR

< DTC/CIRCUIT DIAGNOSIS >

[VK56VD FOR USA AND CANADA]

Is the inspection result normal?

- YES >> GO TO 12.
- NO >> GO TO 11.

## 11. REPLACE CYLINDER HEAD, VVEL LADDER ASSEMBLY AND VVEL ACTUATOR SUB ASSEMBLY

Replace cylinder head, VVEL ladder assembly and VVEL actuator sub assembly.

Refer to [EM-264, "Exploded View"](#) (Cylinder head)

Refer to [EM-246, "Exploded View"](#) (VVEL ladder assembly and VVEL actuator sub assembly).

>> INSPECTION END

## 12. CHECK INTERMITTENT INCIDENT

Refer to [GI-44, "Intermittent Incident"](#).

>> INSPECTION END

## Component Inspection (VVEL ACTUATOR MOTOR)

INFOID:000000007187663

### 1. CHECK VVEL ACTUATOR MOTOR

1. Turn ignition switch OFF.
2. Disconnect VVEL actuator motor harness connector.
3. Check resistance between VVEL actuator motor terminals as per the following.

| VVEL actuator motor | Resistance   |
|---------------------|--------------|
| Terminal            |              |
| 1 and 2             | 16 Ω or less |

Is the inspection result normal?

- YES >> INSPECTION END
- NO >> GO TO 2.

### 2. REPLACE VVEL ACTUATOR SUB ASSEMBLY

Replace VVEL actuator sub assembly. Refer to [EM-246, "Exploded View"](#).

>> INSPECTION END

## Component Inspection (VVEL ACTUATOR SUB ASSEMBLY)

INFOID:000000007187664

### 1. CHECK VVEL ACTUATOR SUB ASSEMBLY

1. Turn ignition switch OFF.
2. Remove VVEL actuator sub assembly. Refer to [EM-246, "Exploded View"](#).
3. Turn the ball screw shaft to check that it works smoothly.

Is the inspection result normal?

- YES >> INSPECTION END
- NO >> GO TO 2.

### 2. REPLACE VVEL ACTUATOR SUB ASSEMBLY

Replace VVEL actuator sub assembly. Refer to [EM-246, "Exploded View"](#).

>> INSPECTION END

# P1091 VVEL ACTUATOR MOTOR RELAY

< DTC/CIRCUIT DIAGNOSIS >

[VK56VD FOR USA AND CANADA]

## P1091 VVEL ACTUATOR MOTOR RELAY

### DTC Logic

INFOID:000000007187665

### DTC DETECTION LOGIC

| DTC No. | Trouble diagnosis name<br>(Trouble diagnosis content)       | DTC detecting condition  | Possible cause  |
|---------|---|--|---|
| P1091   | VVEL ACTR MOT PWR<br>[VVEL actuator motor relay<br>circuit] | <ul style="list-style-type: none"><li>VVEL control module detects the VVEL actuator motor relay is stuck OFF.</li><li>VVEL control module detects the VVEL actuator motor relay is stuck ON.</li></ul> | <ul style="list-style-type: none"><li>Harness or connectors<br/>(VVEL actuator motor relay circuit is open or shorted.)<br/>(Abort circuit is open or shorted.)</li><li>VVEL actuator motor relay</li><li>VVEL control module</li><li>ECM</li></ul> |

### DTC CONFIRMATION PROCEDURE

#### 1. PRECONDITIONING

- Turn ignition switch OFF and wait at least 10 seconds.
- Turn ignition switch ON.
- Turn ignition switch OFF and wait at least 10 seconds.

#### TESTING CONDITION:

Before performing the following procedure, confirm that battery voltage is 10 V or more at idle.

>> GO TO 2.

#### 2. PERFORM DTC CONFIRMATION PROCEDURE

- Turn ignition switch ON and wait at least 1 seconds.
- Turn ignition switch OFF and wait at least 10 seconds.
- Turn ignition switch ON and wait at least 1 seconds.
- Check 1st trip DTC.

Is 1st trip DTC detected?

- YES >> Proceed to [EC-1408, "Diagnosis Procedure"](#).  
NO >> INSPECTION END

### Diagnosis Procedure

INFOID:000000007187666

#### 1. VVEL ACTUATOR MOTOR RELAY POWER SUPPLY CIRCUIT-I

- Turn ignition switch OFF.
- Disconnect VVEL actuator motor relay.
- Check the voltage between VVEL actuator motor relay harness connector and ground.

| VVEL actuator motor relay |          | Ground | Voltage         |
|---------------------------|----------|--------|-----------------|
| Connector                 | Terminal |        |                 |
| E16                       | 1        | Ground | Battery voltage |
|                           | 5        |        |                 |

Is the inspection result normal?

- YES >> GO TO 3.  
NO >> GO TO 2.

#### 2. DETECT MALFUNCTIONING PART

Check the following.

- 50A fusible link (letter G)
- Harness for open or short between VVEL actuator motor relay and battery

>> Repair open circuit, short to ground or short to power in harness or connectors.



# P1091 VVEL ACTUATOR MOTOR RELAY

[VK56VD FOR USA AND CANADA]

< DTC/CIRCUIT DIAGNOSIS >

## 3. VVEL ACTUATOR MOTOR RELAY POWER SUPPLY CIRCUIT-II

1. Disconnect VVEL control module harness connector.
2. Check the continuity between VVEL actuator motor relay harness connector and VVEL control module harness connector.

| VVEL control module |          | VVEL actuator motor relay |          | Continuity |
|---------------------|----------|---------------------------|----------|------------|
| Connector           | Terminal | Connector                 | Terminal |            |
| E15                 | 23       | E16                       | 2        | Existed    |

3. Also check harness for short to ground and power.

Is the inspection result normal?

YES >> GO TO 4.

NO >> Repair open circuit or short to ground or short to power in harness or connectors.

## 4. VVEL ACTUATOR MOTOR RELAY INPUT SIGNAL CIRCUIT FOR OPEN AND SHORT

1. Check the continuity between VVEL actuator motor relay harness connector and VVEL control module harness connector.

| VVEL control module |           |          | VVEL actuator motor relay |          | Continuity |
|---------------------|-----------|----------|---------------------------|----------|------------|
| Bank                | Connector | Terminal | Connector                 | Terminal |            |
| 1                   | E15       | 13       | E16                       | 3        | Existed    |
| 2                   |           | 1        |                           |          |            |

2. Also check harness for short to ground and power.

Is the inspection result normal?

YES >> GO TO 5.

NO >> Repair open circuit, short to ground or short to power in harness or connectors.

## 5. CHECK VVEL ACTUATOR MOTOR RELAY

Refer to [EC-1410, "Component Inspection \(VVEL Actuator Motor Relay\)"](#).

Is the inspection result normal?

YES >> GO TO 6.

NO >> Replace VVEL actuator motor relay.

## 6. CHECK ABORT CIRCUIT FOR OPEN AND SHORT

1. Disconnect ECM harness connector.
2. Check the continuity between VVEL control module harness connector and ECM harness connector.

| VVEL control module |          | ECM       |          | Continuity |
|---------------------|----------|-----------|----------|------------|
| Connector           | Terminal | Connector | Terminal |            |
| E15                 | 21       | M160      | 122      | Existed    |

3. Also check harness for short to ground and power.

Is the inspection result normal?

YES >> GO TO 8.

NO >> GO TO 7.

## 7. DETECT MALFUNCTIONING PART

Check the following.

- Harness for open and short between ECM and VVEL control module
- Loose or poor connection for each connector and harness

>> Repair open circuit, short to ground or short to power in harness or connectors.

## 8. CHECK INTERMITTENT INCIDENT

Refer to [GI-44, "Intermittent Incident"](#).

# P1091 VVEL ACTUATOR MOTOR RELAY

[VK56VD FOR USA AND CANADA]

< DTC/CIRCUIT DIAGNOSIS >

Is the inspection result normal?

- YES >> GO TO 9.
- NO >> Repair or replace.

## 9. REPLACE VVEL CONTROL MODULE

Replace VVEL control module. Refer to [EC-1554, "Removal and Installation"](#).

>> GO TO 10.

## 10. PERFORM DTC CONFIRMATION PROCEDURE

1. Turn ignition switch ON.
2. Erase DTC.
3. Perform DTC Confirmation Procedure.  
See [EC-1408, "DTC Logic"](#).

Is the DTC P1091 displayed again?

- YES >> GO TO 11.
- NO >> INSPECTION END

## 11. REPLACE ECM

Replace ECM. Refer to [EC-1553, "Removal and Installation"](#).

>> INSPECTION END

## Component Inspection (VVEL Actuator Motor Relay)

INFOID:000000007187667

### 1. CHECK VVEL ACTUATOR MOTOR RELAY

1. Turn ignition switch OFF.
2. Remove VVEL actuator motor relay.
3. Check the continuity between VVEL actuator motor relay terminals under the following conditions.

| Terminal | Condition   | Continuity  |
|----------|---|-------------|
| 3 and 5  | 12V direct current supply between terminals 1 and 2 | Existed     |
|          | No current supply                                   | Not existed |

Is the inspection result normal?

- YES >> INSPECTION END
- NO >> Replace VVEL actuator motor relay.

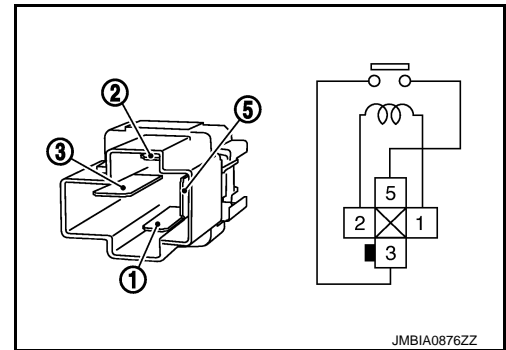

# P1148, P1168 CLOSED LOOP CONTROL

< DTC/CIRCUIT DIAGNOSIS >

[VK56VD FOR USA AND CANADA]

## P1148, P1168 CLOSED LOOP CONTROL

### DTC Logic

INFOID:000000007187668

### DTC DETECTION LOGIC

**NOTE:**

DTC P1148 or P1168 is displayed with DTC for A/F sensor 1.

When the DTC is detected, perform the trouble diagnosis of DTC corresponding to A/F sensor 1.

| DTC No. | Trouble diagnosis name<br>(Trouble diagnosis content)        | DTC detecting condition  | Possible cause  |
|---------|--|--|---|
| P1148   | CLOSED LOOP-B1<br>[Closed loop control function<br>(bank 1)] | The closed loop control function for bank 1 does not operate even when vehicle is being driven in the specified condition. | <ul style="list-style-type: none"><li>• Harness or connectors<br/>(The A/F sensor 1 circuit is open or shorted.)</li><li>• A/F sensor 1</li><li>• A/F sensor 1 heater</li></ul> |
| P1168   | CLOSED LOOP-B2<br>[Closed loop control function<br>(bank 2)] | The closed loop control function for bank 2 does not operate even when vehicle is being driven in the specified condition. |   |

### Diagnosis Procedure

INFOID:000000007187669

DTC P1148 or P1168 is displayed with DTC for A/F sensor 1.

When the DTC is detected, perform the trouble diagnosis of DTC corresponding to A/F sensor 1. Refer to [EC-1083, "DTC Index"](#).

# P1197 OUT OF GAS

< DTC/CIRCUIT DIAGNOSIS >

[VK56VD FOR USA AND CANADA]

## P1197 OUT OF GAS

### Description

INFOID:000000007187670

This diagnosis result is detected when the fuel level of the fuel tank is extremely low and the engine does not run normally.

### DTC Logic

INFOID:000000007187671

### DTC DETECTION LOGIC

| DTC No. | Trouble diagnosis name<br>(Trouble diagnosis content) | DTC detecting condition   | Possible cause  |
|---------|---|---|---|
| P1197   | FUEL RUN OUT<br>(Out of gas)                          | <ul style="list-style-type: none"><li>Fuel rail pressure remains at 1.5 MPa (15 bar, 15.3 kg/cm<sup>2</sup>, 217.5 psi) or less for 3 seconds or more with the fuel level too low.</li><li>Fuel rail pressure remains 2.7 MPa (27 bar, 27.5 kg/cm<sup>2</sup>, 392 psi) lower than a target fuel pressure for 5 seconds or more with the fuel level too low.</li><li>Fuel rail pressure remains at 0.23 MPa (2.3 bar, 2.346 kg/cm<sup>2</sup>, 33.35 psi) or less for 5 seconds or more with the fuel level too low.</li></ul> <b>NOTE:</b><br>Allow engine coolant temperature to reach 70°C (158°F) or more once. | <ul style="list-style-type: none"><li>Out of gas</li><li>Harness or connectors (The low pressure fuel pump circuit is open or shorted.)</li><li>Low pressure fuel pump</li><li>Fuel pressure regulator</li><li>Low pressure fuel system</li><li>Low fuel pressure sensor</li><li>Harness or connectors (The high pressure fuel pump circuit is shorted.)</li><li>High pressure fuel pump</li><li>High pressure fuel system</li><li>Fuel rail pressure sensor</li><li>Disconnection of the fuel hose</li></ul> |

### DTC CONFIRMATION PROCEDURE

#### 1. PRECONDITIONING

- Turn ignition switch OFF and wait at least 10 seconds.
- Turn ignition switch ON.
- Turn ignition switch OFF and wait at least 10 seconds.

#### TESTING CONDITION:

Before performing the following procedure, confirm that battery voltage is 11 V or more at idle.

>> GO TO 2.

#### 2. PERFORM DTC CONFIRMATION PROCEDURE-I

Start the engine.

Does the engine start?

- YES >> GO TO 3.  
NO >> Proceed to [EC-1413, "Diagnosis Procedure"](#).

#### 3. PERFORM DTC CONFIRMATION PROCEDURE-II

- Warm up the engine to the normal operating temperature.  
**NOTE:**  
For best results, warm up the engine until "COOLAN TEMP/S" on "DATA MONITOR" of CONSULT reaches at least 70°C (158°F).
- Keep the engine speed at 3,500 rpm for 5 seconds and let it idle at least 60 seconds..
- Check the 1st trip DTC.

#### NOTE:

If the fuel tank has sufficient fuel, this diagnosis result may not be detected.

Is 1st trip DTC detected?

- YES >> Proceed to [EC-1413, "Diagnosis Procedure"](#).  
NO >> INSPECTION END

# P1197 OUT OF GAS

[VK56VD FOR USA AND CANADA]

< DTC/CIRCUIT DIAGNOSIS >

INFOID:000000007187672

## Diagnosis Procedure

### 1. REFUEL THE VEHICLE

1. Refuel 10 liter (10 US qt, 8 imp qt).

**CAUTION:**

**Never refuel more than 10 liter.**

2. Start the engine and keep the engine speed at 3,000 rpm for 30 seconds.

**NOTE:**

For best results, warm up the engine until "COOLAN TEMP/S" on "DATA MONITOR" of CONSULT reaches at least 70°C (158°F).

3. Turn ignition switch OFF and wait at least 10 seconds.
4. Turn ignition switch ON.
5. Turn ignition switch OFF and wait at least 10 seconds.
6. Turn ignition switch ON.
7. Erase the DTC.
8. Start the engine and let it idle at least 60 seconds.
9. Perform the confirmation procedure again. Refer to [EC-1412, "DTC Logic"](#).

Is 1st trip DTC detected?

YES >> GO TO 2.

NO >> INSPECTION END

### 2. CHECK LOW PRESSURE FUEL PUMP

Refer to [EC-1531, "Component Function Check"](#).

Is inspection result normal?

YES >> GO TO 3.

NO >> Repair or replace error-detected parts.

### 3. CHECK HIGH PRESSURE FUEL PUMP

Refer to [EC-1520, "Component Function Check"](#).

Is inspection result normal?

YES >> Check the fuel hose for disconnection and looseness.

NO >> Repair or replace error-detected parts.

A

EC

C

D

E

F

G

H

I

J

K

L

M

N

O

P

# P1212 TCS COMMUNICATION LINE

< DTC/CIRCUIT DIAGNOSIS >

[VK56VD FOR USA AND CANADA]

## P1212 TCS COMMUNICATION LINE

### Description

INFOID:000000007187676

This CAN communication line is used to control the smooth engine operation during the TCS operation. Pulse signals are exchanged between ECM and “ABS actuator and electric unit (control unit)”.

**Be sure to erase the malfunction information such as DTC not only for “ABS actuator and electric unit (control unit)” but also for ECM after TCS related repair.**

### DTC Logic

INFOID:000000007187677

### DTC DETECTION LOGIC

#### NOTE:

- If DTC P1212 is displayed with DTC UXXXX, perform the trouble diagnosis for DTC UXXXX.
  - If DTC P1212 is displayed with DTC P0607, perform the trouble diagnosis for DTC P0607.
- Freeze frame data is not stored in the ECM for this self-diagnosis.

| DTC No. | Trouble diagnosis name<br>(Trouble diagnosis content) | DTC detecting condition   | Possible cause   |
|---------|---|---|--|
| P1212   | TCS/CIRC<br>(TCS communication line)                  | ECM cannot receive the information from “ABS actuator and electric unit (control unit)” continuously. | <ul style="list-style-type: none"><li>• Harness or connectors<br/>(The CAN communication line is open or shorted.)</li><li>• ABS actuator and electric unit (control unit)</li><li>• Dead (Weak) battery</li></ul> |

### DTC CONFIRMATION PROCEDURE

#### 1. PRECONDITIONING

1. Turn ignition switch OFF and wait at least 10 seconds.
2. Turn ignition switch ON.
3. Turn ignition switch OFF and wait at least 10 seconds.

#### TESTING CONDITION:

**Before performing the following procedure, confirm that battery voltage is 10.5 V or more at idle.**

>> GO TO 2.

#### 2. PERFORM DTC CONFIRMATION PROCEDURE

1. Start engine and let it idle for at least 10 seconds.
2. Check 1st trip DTC.

#### Is 1st trip DTC detected?

YES >> Proceed to [EC-1414, "Diagnosis Procedure"](#).

NO >> INSPECTION END

### Diagnosis Procedure

INFOID:000000007187678

Perform the trouble diagnosis for TCS. Refer to [BRC-55, "Work Flow"](#).

#### NOTE:

If DTC P1212 is displayed with DTC UXXXX and/or P0607, perform the following trouble diagnosis.

- Trouble diagnosis for DTC UXXXX Refer to [EC-1083, "DTC Index"](#).
- Trouble diagnosis for DTC P0607 Refer to [EC-1386, "DTC Logic"](#).

# P1217 ENGINE OVER TEMPERATURE

< DTC/CIRCUIT DIAGNOSIS >

[VK56VD FOR USA AND CANADA]

## P1217 ENGINE OVER TEMPERATURE

### DTC Logic

INFOID:000000007187679

### DTC DETECTION LOGIC

#### NOTE:

- If DTC P1217 is displayed with DTC UXXXX, first perform the trouble diagnosis for DTC UXXXX.
- If DTC P1217 is displayed with DTC P0607, first perform the trouble diagnosis for DTC P0607. Refer to [EC-1386, "DTC Logic"](#).

If the cooling fan or another component in the cooling system malfunctions, engine coolant temperature will rise.

When the engine coolant temperature reaches an abnormally high temperature condition, a malfunction is indicated.

| DTC No. | Trouble diagnosis name<br>(Trouble diagnosis content)    | DTC detecting condition  | Possible cause  |
|---------|--|--|---|
| P1217   | ENG OVER TEMP<br>[Engine over temperature<br>(Overheat)] | <ul style="list-style-type: none"><li>• Cooling fan does not operate properly (Overheat).</li><li>• Cooling fan system does not operate properly (Overheat).</li><li>• Engine coolant was not added to the system using the proper filling method.</li><li>• Engine coolant is not within the specified range.</li></ul> | <ul style="list-style-type: none"><li>• Harness or connectors<br/>(The cooling fan circuit is open or shorted.)</li><li>• IPDM E/R</li><li>• Cooling fan control module</li><li>• Cooling fan motor</li><li>• Radiator hose</li><li>• Radiator</li><li>• Radiator cap</li><li>• Water pump</li><li>• Thermostat</li></ul> |

#### CAUTION:

When a malfunction is indicated, always replace the coolant. Refer to [CO-34, "Draining"](#) and [CO-35, "Refilling"](#). Also, replace the engine oil. Refer to [MA-36, "ENGINE OIL : Draining"](#) and [MA-36, "ENGINE OIL : Refilling"](#).

1. Fill radiator with coolant up to specified level with a filling speed of 2 liters per minute. Always use coolant with the proper mixture ratio. Refer to [MA-17, "FOR NORTH AMERICA : Anti-Freeze Coolant Mixture Ratio"](#).
2. After refilling coolant, run engine to ensure that no water-flow noise is emitted.

### DTC CONFIRMATION PROCEDURE

#### 1. PERFORM COMPONENT FUNCTION CHECK

Perform component function check. Refer to [EC-1415, "Component Function Check"](#).

#### NOTE:

Use component function check to check the overall function of the cooling fan. During this check, a DTC might not be confirmed.

Is the inspection result normal?

YES >> INSPECTION END

NO >> Proceed to [EC-1416, "Diagnosis Procedure"](#).

### Component Function Check

INFOID:000000007187680

#### 1. PERFORM COMPONENT FUNCTION CHECK-I

#### WARNING:

Never remove the radiator cap when the engine is hot. Serious burns could be caused by high pressure fluid escaping from the radiator.

Wrap a thick cloth around cap. Carefully remove the cap by turning it a quarter turn to allow built-up pressure to escape. Then turn the cap all the way off.

# P1217 ENGINE OVER TEMPERATURE

[VK56VD FOR USA AND CANADA]

## < DTC/CIRCUIT DIAGNOSIS >

Check the coolant level in the reservoir tank and radiator.

**Allow engine to cool before checking coolant level.**

Is the coolant level in the reservoir tank and/or radiator below the proper range?

- YES >> Proceed to [EC-1416, "Diagnosis Procedure"](#).  
NO >> GO TO 2.

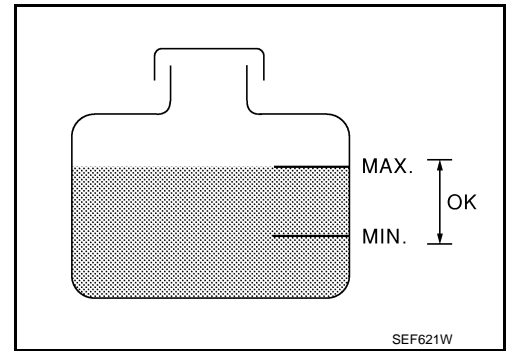

## 2.PERFORM COMPONENT FUNCTION CHECK-II

Confirm whether customer filled the coolant or not.

Did customer fill the coolant?

- YES >> Proceed to [EC-1416, "Diagnosis Procedure"](#).  
NO >> GO TO 3.

## 3.PERFORM COMPONENT FUNCTION CHECK-III

### WITH CONSULT

1. Turn ignition switch ON.
2. Perform "FAN DUTY CONTROL" in "ACTIVE TEST" mode with CONSULT.
3. Check that cooling fan speed varies according to the percentage.

### WITHOUT CONSULT

Perform IPDM E/R auto active test and check cooling fan motors operation, refer to [PCS-12, "Diagnosis Description"](#).

Is the inspection result normal?

- YES >> INSPECTION END  
NO >> Proceed to [EC-1416, "Diagnosis Procedure"](#).

## Diagnosis Procedure

INFOID:000000007187681

## 1.CHECK COOLING FAN OPERATION

### WITH CONSULT

1. Turn ignition switch ON.
2. Perform "FAN DUTY CONTROL" in "ACTIVE TEST" mode with CONSULT.
3. Check that cooling fan speed varies according to the percentage.

### WITHOUT CONSULT

1. Perform IPDM E/R auto active test and check cooling fan motors operation, refer to [PCS-12, "Diagnosis Description"](#).
2. Check that cooling fan operates.

Is the inspection result normal?

- YES >> GO TO 2.  
NO >> Proceed to [EC-1510, "Diagnosis Procedure"](#).

## 2.CHECK COOLING SYSTEM FOR LEAKAGE-I

Check cooling system for leakage. Refer to [CO-34, "Inspection"](#).

Is leakage detected?

- YES >> GO TO 3.  
NO >> GO TO 4.

## 3.CHECK COOLING SYSTEM FOR LEAKAGE-II

Check the following for leakage.

- Hose
- Radiator
- Water pump



# P1217 ENGINE OVER TEMPERATURE

[VK56VD FOR USA AND CANADA]

< DTC/CIRCUIT DIAGNOSIS >

>> Repair or replace malfunctioning part.

## 4.CHECK RADIATOR CAP

Check radiator cap. Refer to [MA-34, "RADIATOR CAP : Inspection"](#).

Is the inspection result normal?

YES >> GO TO 5.

NO >> Replace radiator cap. Refer to [CO-48, "Exploded View"](#).

## 5.CHECK THERMOSTAT

Check thermostat. Refer to [CO-49, "Inspection"](#).

Is the inspection result normal?

YES >> GO TO 6.

NO >> Replace thermostat. Refer to [CO-48, "Exploded View"](#).

## 6.CHECK ENGINE COOLANT TEMPERATURE SENSOR

Refer to [EC-1224, "Component Inspection \(Engine Coolant Temperature Sensor\)"](#).

Is the inspection result normal?

YES >> GO TO 7.

NO >> Replace engine coolant temperature sensor. Refer to [CO-48, "Exploded View"](#).

## 7.OVERHEATING CAUSE ANALYSIS

If the cause cannot be isolated, check the [CO-32, "Troubleshooting Chart"](#).

>> INSPECTION END

A

EC

C

D

E

F

G

H

I

J

K

L

M

N

O

P

# P1220 FUEL PUMP CONTROL MODULE (FPCM)

< DTC/CIRCUIT DIAGNOSIS >

[VK56VD FOR USA AND CANADA]

## P1220 FUEL PUMP CONTROL MODULE (FPCM)

### DTC Logic

INFOID:000000007187682

### DTC DETECTION LOGIC

| DTC No. | Trouble diagnosis name<br>(Trouble diagnosis content) | DTC detecting condition   | Possible cause  |
|---------|---|---|---|
| P1220   | FPCM<br>(Fuel pump control module)                    | During engine cranking, the signal voltage of the FPCM to the ECM is too low. | <ul style="list-style-type: none"><li>• Harness or connectors (FPCM circuit is open or shorted)<br/>(Fuel pump circuit is open or shorted)</li><li>• FPCM</li></ul> |

### DTC CONFIRMATION PROCEDURE

#### 1. PRECONDITIONING

If DTC Confirmation Procedure has been previously conducted, always perform the following procedure before conducting the next test.

1. Turn ignition switch OFF and wait at least 10 seconds.
2. Turn ignition switch ON.
3. Turn ignition switch OFF and wait at least 10 seconds.

#### TESTING CONDITION:

- Before performing the following procedure, confirm that battery voltage is between 12 - 15 V at idle.
- Before performing the following procedure, check that the engine coolant temperature is  $-10^{\circ}\text{C}$  ( $14^{\circ}\text{F}$ ) or more.

>> GO TO 2.

#### 2. PERFORM DTC CONFIRMATION PROCEDURE

1. Start engine and let it idle for at least 5 seconds.  
If engine does not start, crank engine for at least 5 seconds.
2. Check DTC.

#### Is DTC detected?

YES >> Proceed to [EC-1418. "Diagnosis Procedure"](#).

NO >> INSPECTION END

### Diagnosis Procedure

INFOID:000000007187683

#### 1. CHECK FPCM POWER SUPPLY CIRCUIT

1. Turn ignition switch OFF.
2. Disconnect FPCM harness connector.
3. Turn ignition switch ON.
4. Check the voltage between FPCM harness connector and ground.

| FPCM      |          | Ground | Voltage         |
|-----------|----------|--------|-----------------|
| Connector | Terminal |        |                 |
| B221      | 10       | Ground | Battery voltage |

#### Is the inspection result normal?

YES >> GO TO 2.

NO >> GO TO 3.

#### 2. DETECT MALFUNCTIONING PART

Check the following.

- 15 A fuse (No.41)
- Harness for open or short between FPCM and IPDM E/R
- Loose or poor connection for each connector and harness

# P1220 FUEL PUMP CONTROL MODULE (FPCM)

[VK56VD FOR USA AND CANADA]

## < DTC/CIRCUIT DIAGNOSIS >

>> Repair open circuit, short to ground or short to power in harness or connectors.

### 3.CHECK FPCM GROUND CIRCUIT FOR OPEN AND SHORT

1. Turn ignition switch OFF.
2. Check the continuity between FPCM harness connector and ground.

| FPCM      |          | Ground | Continuity |
|-----------|----------|--------|------------|
| Connector | Terminal |        |            |
| B221      | 5        | Ground | Existed    |

3. Also check harness for short to power.

Is the inspection result normal?

YES >> GO TO 4.

NO >> Repair open circuit or short to power in harness or connectors.

### 4.CHECK FPCM INPUT AND OUTPUT CIRCUITS FOR OPEN AND SHORT

1. Disconnect ECM harness connector.
2. Check the continuity between FPCM harness connector and ECM harness connector.

| FPCM      |          | ECM       |          | Continuity |
|-----------|----------|-----------|----------|------------|
| Connector | Terminal | Connector | Terminal |            |
| B221      | 8        | M160      | 125      | Existed    |
|           | 9        |           | 142      |            |

3. Also check harness for short to ground and short to power.

Is the inspection result normal?

YES >> GO TO 6.

NO >> GO TO 5.

### 5.DETECT MALFUNCTIONING PART

Check the following.

- Harness for open or short between FPCM and ECM
- Loose or poor connection for each connector and harness

>> Repair open circuit, short to ground or short to power in harness or connectors.

### 6.CHECK FUEL PUMP CONTROL CIRCUIT FOR OPEN AND SHORT

1. Disconnect "fuel level sensor unit and fuel pump (main)" harness connector.
2. Check the continuity between FPCM harness connector and "fuel level sensor unit and fuel pump (main)" harness connector.

| FPCM      |          | Fuel level sensor unit and fuel pump (main) |          | Continuity |
|-----------|----------|---|----------|------------|
| Connector | Terminal | Connector                                   | Terminal |            |
| B221      | 6        | B241  | 3        | Existed    |
|           | 7        |   | 1        |            |

3. Also check harness for short to ground and short to power.

Is the inspection result normal?

YES >> GO TO 7.

NO >> Repair open circuit, short to ground or short to power in harness or connectors.

### 7.CHECK FPCM

Refer to [EC-1420. "Component Inspection \(FPCM\)".](#)

Is the inspection result normal?

YES >> GO TO 8.

NO >> Replace FPCM. Refer to [EC-1555. "Removal and Installation".](#)

# P1220 FUEL PUMP CONTROL MODULE (FPCM)

< DTC/CIRCUIT DIAGNOSIS >

[VK56VD FOR USA AND CANADA]

## 8. CHECK INTERMITTENT INCIDENT

Refer to [GI-44. "Intermittent Incident"](#).

>> INSPECTION END

## Component Inspection (FPCM)

INFOID:000000007187684

## 1. CHECK FUEL PUMP CONTROL MODULE (FPCM)

1. Check the voltage between FPCM terminals under the following conditions.

| FPCM      |          |          | Condition   | Voltage      |
|-----------|----------|----------|---|--------------|
| Connector | +        | -        |   |              |
|           | Terminal | Terminal |   |              |
| B221      | 7        | 6        | For 1 second after turning ignition switch ON       | Approx. 10 V |
|           |          |          | More than 1 second after turning ignition switch ON | Approx. 0 V  |
|           |          |          | Idle speed  | Approx. 10 V |

Is the inspection result normal?

YES >> INSPECTION END

NO >> Replace FPCM. Refer to [EC-1555. "Removal and Installation"](#).

# P1225, P1234 TP SENSOR

< DTC/CIRCUIT DIAGNOSIS >

[VK56VD FOR USA AND CANADA]

## P1225, P1234 TP SENSOR

### DTC Logic

INFOID:000000007187685

### DTC DETECTION LOGIC

| DTC No. | Trouble diagnosis name<br>(Trouble diagnosis content)                       | DTC detecting condition                                     | Possible cause   |
|---------|---|---|--|
| P1225   | CTP LEARNING-B1<br>[Closed throttle position learning performance (bank 1)] | Closed throttle position learning value is excessively low. | • Electric throttle control actuator (TP sensor 1 and 2) |
| P1234   | CTP LEARNING-B2<br>[Closed throttle position learning performance (bank 2)] |   |  |

### DTC CONFIRMATION PROCEDURE

#### 1. PRECONDITIONING

1. Turn ignition switch OFF and wait at least 10 seconds.
2. Turn ignition switch ON.
3. Turn ignition switch OFF and wait at least 10 seconds.

#### TESTING CONDITION:

Before performing the following procedure, confirm that battery voltage is 10 V or more at idle.

>> GO TO 2.

#### 2. PERFORM DTC CONFIRMATION PROCEDURE

1. Turn ignition switch ON.
2. Turn ignition switch OFF and wait at least 10 seconds.
3. Turn ignition switch ON.
4. Check 1st trip DTC.

Is 1st trip DTC detected?

- YES >> Proceed to [EC-1421, "Diagnosis Procedure"](#).  
NO >> INSPECTION END

### Diagnosis Procedure

INFOID:000000007187686

#### 1. CHECK ELECTRIC THROTTLE CONTROL ACTUATOR VISUALLY

1. Turn ignition switch OFF.
2. Remove the intake air duct. Refer to [EM-184, "Exploded View"](#).
3. Check that no foreign matter is caught between the throttle valve and the housing.

Is the inspection result normal?

- YES >> GO TO 2.  
NO >> Remove the foreign matter and clean the electric throttle control actuator inside, and then perform throttle valve closed position learning. Refer to [EC-1121, "Work Procedure"](#).

#### 2. REPLACE ELECTRIC THROTTLE CONTROL ACTUATOR

Replace malfunctioning electric throttle control actuator. Refer to [EM-191, "Removal and Installation"](#).

>> INSPECTION END

# P1226, P1235 TP SENSOR

< DTC/CIRCUIT DIAGNOSIS >

[VK56VD FOR USA AND CANADA]

## P1226, P1235 TP SENSOR

### DTC Logic

INFOID:000000007187687

### DTC DETECTION LOGIC

| DTC No. | Trouble diagnosis name<br>(Trouble diagnosis content)                       | DTC detecting condition  | Possible cause   |
|---------|---|--|--|
| P1226   | CTP LEARNING-B1<br>[Closed throttle position learning performance (bank 1)] | Closed throttle position learning is not performed successfully, repeatedly. | • Electric throttle control actuator (TP sensor 1 and 2) |
| P1235   | CTP LEARNING-B2<br>[Closed throttle position learning performance (bank 2)] |  |  |

### DTC CONFIRMATION PROCEDURE

#### 1. PRECONDITIONING

1. Turn ignition switch OFF and wait at least 10 seconds.
2. Turn ignition switch ON.
3. Turn ignition switch OFF and wait at least 10 seconds.

#### TESTING CONDITION:

Before performing the following procedure, confirm that battery voltage is 10 V or more at idle.

>> GO TO 2.

#### 2. PERFORM DTC CONFIRMATION PROCEDURE

1. Turn ignition switch ON.
2. Turn ignition switch OFF and wait at least 10 seconds.
3. Turn ignition switch ON.
4. Repeat steps 2 and 3 for 32 times.
5. Check 1st trip DTC.

Is 1st trip DTC detected?

- YES >> Proceed to [EC-1422, "Diagnosis Procedure"](#).  
NO >> INSPECTION END

### Diagnosis Procedure

INFOID:000000007187688

#### 1. CHECK ELECTRIC THROTTLE CONTROL ACTUATOR VISUALLY

1. Turn ignition switch OFF.
2. Remove the intake air duct. Refer to [EM-184, "Exploded View"](#).
3. Check that no foreign matter is caught between the throttle valve and the housing.

Is the inspection result normal?

- YES >> GO TO 2.  
NO >> Remove the foreign matter and clean the electric throttle control actuator inside, and then perform throttle valve closed position learning. Refer to [EC-1121, "Work Procedure"](#).

#### 2. REPLACE ELECTRIC THROTTLE CONTROL ACTUATOR

Replace malfunctioning electric throttle control actuator. Refer to [EM-191, "Removal and Installation"](#).

>> INSPECTION END

# P1233, P2101 ELECTRIC THROTTLE CONTROL FUNCTION

< DTC/CIRCUIT DIAGNOSIS >

[VK56VD FOR USA AND CANADA]

## P1233, P2101 ELECTRIC THROTTLE CONTROL FUNCTION

### DTC Logic

INFOID:000000007187689

#### DTC DETECTION LOGIC

##### NOTE:

If DTC P1233 or P2101 is displayed with DTC P1238, P2119, perform the trouble diagnosis for DTC P1238, P2119. Refer to [EC-1429, "DTC Logic"](#).

If DTC P1233 or P2101 is displayed with DTC P2100, perform the trouble diagnosis for DTC P1290, P2100. Refer to [EC-1485, "DTC Logic"](#).

| DTC No. | Trouble diagnosis name<br>(Trouble diagnosis content)                 | DTC detecting condition                                       | Possible cause   |
|---------|---|---|--|
| P1233   | ETC FNCTN/CIRC-B2<br>[Electric throttle control performance (bank 2)] | Electric throttle control function does not operate properly. | <ul style="list-style-type: none"><li>Harness or connectors<br/>(Throttle control motor circuit is open or shorted)</li><li>Electric throttle control actuator</li></ul> |
| P2101   | ETC FNCTN/CIRC-B1<br>[Electric throttle control performance (bank 1)] |   |  |

#### DTC CONFIRMATION PROCEDURE

##### 1. PRECONDITIONING

- Turn ignition switch OFF and wait at least 10 seconds.
- Turn ignition switch ON.
- Turn ignition switch OFF and wait at least 10 seconds.

##### TESTING CONDITION:

Before performing the following procedure, confirm that battery voltage is 11 V or more when engine is running.

>> GO TO 2.

##### 2. PERFORM DTC CONFIRMATION PROCEDURE

- Turn ignition switch ON and wait at least 2 seconds.
- Start engine and let it idle for 5 seconds.
- Check DTC.

Is DTC detected?

- YES >> Proceed to [EC-1423, "Diagnosis Procedure"](#).  
NO >> INSPECTION END

#### Diagnosis Procedure

INFOID:000000007187690

##### 1. CHECK THROTTLE CONTROL MOTOR RELAY INPUT SIGNAL CIRCUIT-I

Check the voltage between ECM harness connector terminals as per the following.

| DTC   | ECM       |          |           |          | Condition           | Voltage (V)     |
|-------|-----------|----------|-----------|----------|---------------------|-----------------|
|       | +         |          | -         |          |                     |                 |
|       | Connector | Terminal | Connector | Terminal |                     |                 |
| P1233 | M160      | 173      | M160      | 175      | Ignition switch OFF | Approx. 0       |
| P2101 |           |          |           |          | Ignition switch ON  | Battery voltage |

Is the inspection result normal?

- YES >> GO TO 8.  
NO >> GO TO 2.

##### 2. CHECK THROTTLE CONTROL MOTOR RELAY POWER SUPPLY CIRCUIT

- Turn ignition switch OFF.

# P1233, P2101 ELECTRIC THROTTLE CONTROL FUNCTION

[VK56VD FOR USA AND CANADA]

## < DTC/CIRCUIT DIAGNOSIS >

2. Disconnect ECM harness connector.
3. Disconnect IPDM E/R harness connector E5.
4. Check the continuity between IPDM E/R harness connector and ECM harness connector.

| IPDM E/R  |          | ECM       |          | Continuity |
|-----------|----------|-----------|----------|------------|
| Connector | Terminal | Connector | Terminal |            |
| E5        | 7        | M160      | 173      | Existed    |

5. Also check harness for short to ground and short to power.

### Is the inspection result normal?

YES >> GO TO 4.

NO >> GO TO 3.

## 3. DETECT MALFUNCTIONING PART

Check the following.

- Harness for open or short between ECM and IPDM E/R
- Loose or poor connection for each connector and harness

>> Repair open circuit, short to ground or short to power in harness or connectors.

## 4. CHECK THROTTLE CONTROL MOTOR RELAY INPUT SIGNAL CIRCUIT-II

1. Check the continuity between IPDM E/R harness connector and ECM harness connector.

| DTC            | IPDM E/R  |          | ECM       |          | Continuity |
|----------------|-----------|----------|-----------|----------|------------|
|                | Connector | Terminal | Connector | Terminal |            |
| P1233<br>P2101 | E7        | 71       | M160      | 123      | Existed    |

2. Also check harness for short to ground and short to power.

### Is the inspection result normal?

YES >> GO TO 6.

NO >> GO TO 5.

## 5. DETECT MALFUNCTIONING PART

Check the following.

- Harness for open or short between ECM and IPDM E/R
- Loose or poor connection for each connector and harness

>> Repair open circuit, short to ground or short to power in harness or connectors.

## 6. CHECK FUSE

1. Disconnect 15 A fuse (No. 50) from IPDM E/R.
2. Check if 15 A fuse is blown.

### Is the inspection result normal?

YES >> GO TO 7.

NO >> Replace 15 A fuse.

## 7. CHECK INTERMITTENT INCIDENT

Refer to [GI-44, "Intermittent Incident"](#).

### Is the inspection result normal?

YES >> Replace IPDM E/R. Refer to [PCS-33, "Removal and Installation"](#).

NO >> Repair or replace harness or connectors.

## 8. CHECK THROTTLE CONTROL MOTOR OUTPUT SIGNAL CIRCUIT FOR OPEN OR SHORT

1. Turn ignition switch OFF.
2. Disconnect electric throttle control actuator harness connector.
3. Disconnect ECM harness connector.



# P1233, P2101 ELECTRIC THROTTLE CONTROL FUNCTION

[VK56VD FOR USA AND CANADA]

< DTC/CIRCUIT DIAGNOSIS >

4. Check the continuity between electric throttle control actuator harness connector and ECM harness connector.

| DTC   | Electric throttle control actuator |           |          | ECM       |             | Continuity  |
|-------|------------------------------------|-----------|----------|-----------|-------------|-------------|
|       | Bank                               | Connector | Terminal | Connector | Terminal    |             |
| P1233 | 2                                  | F64       | 5        | F111      | 62          | Not existed |
|       |                                    |           | 6        |           | 58          | Existed     |
|       |                                    |           |          |           | 62          | Existed     |
|       |                                    |           | 58       |           | Not existed |             |
| P2101 | 1                                  | F66       | 5        | F111      | 57          | Not existed |
|       |                                    |           | 6        |           | 63          | Existed     |
|       |                                    |           |          |           | 57          | Existed     |
|       |                                    |           | 63       |           | Not existed |             |

5. Also check harness for short to ground and short to power.

Is the inspection result normal?

YES >> GO TO 9.

NO >> Repair or replace malfunctioning part.

## 9. CHECK ELECTRIC THROTTLE CONTROL ACTUATOR VISUALLY

1. Remove the intake air duct. Refer to [EM-178, "Exploded View"](#).
2. Check that no foreign matter is caught between the throttle valve and the housing.

Is the inspection result normal?

YES >> GO TO 10.

NO >> Remove the foreign matter and clean the electric throttle control actuator inside, and then perform throttle valve closed position learning. Refer to [EC-1121, "Work Procedure"](#).

## 10. CHECK THROTTLE CONTROL MOTOR

Refer to [EC-1425, "Component Inspection \(Electric Throttle Control Motor\)"](#).

Is the inspection result normal?

YES >> GO TO 11.

NO >> GO TO 12.

## 11. CHECK INTERMITTENT INCIDENT

Refer to [GI-44, "Intermittent Incident"](#).

Is the inspection result normal?

YES >> GO TO 12.

NO >> Repair or replace harness or connectors.

## 12. REPLACE ELECTRIC THROTTLE CONTROL ACTUATOR

Replace malfunction electric throttle control actuator. Refer to [EM-191, "Removal and Installation"](#).

>> INSPECTION END

## Component Inspection (Electric Throttle Control Motor)

INFOID:000000007187691

### 1. CHECK THROTTLE CONTROL MOTOR

1. Turn ignition switch OFF.
2. Disconnect electric throttle control actuator harness connector.
3. Check resistance between electric throttle control actuator terminals as per the following.

# P1233, P2101 ELECTRIC THROTTLE CONTROL FUNCTION

< DTC/CIRCUIT DIAGNOSIS >

[VK56VD FOR USA AND CANADA]

| Electric throttle control actuator |           |           | Resistance                               |
|------------------------------------|-----------|-----------|--|
| Bank                               | Connector | Terminals |  |
| 1                                  | F66       | 5 and 6   | Approx. 1 - 15 $\Omega$ [at 25°C (77°F)] |
| 2                                  | F64       | 5 and 6   |  |

Is the inspection result normal?

YES >> INSPECTION END

NO >> GO TO 2.

## 2. REPLACE ELECTRIC THROTTLE CONTROL ACTUATOR

Replace malfunctioning electric throttle control actuator. Refer to [EM-191, "Removal and Installation"](#).

>> INSPECTION END

# P1236, P2118 THROTTLE CONTROL MOTOR

< DTC/CIRCUIT DIAGNOSIS >

[VK56VD FOR USA AND CANADA]

## P1236, P2118 THROTTLE CONTROL MOTOR

### DTC Logic

INFOID:000000007187692

### DTC DETECTION LOGIC

| DTC No. | Trouble diagnosis name<br>(Trouble diagnosis content)            | DTC detecting condition   | Possible cause  |
|---------|--|---|---|
| P1236   | ETC MOT-B2<br>[Throttle control motor (bank 2)<br>circuit short] | ECM detects short in both circuits between<br>ECM and throttle control motor. | <ul style="list-style-type: none"> <li>Harness or connectors<br/>(Throttle control motor circuit is shorted.)</li> <li>Electric throttle control actuator<br/>(Throttle control motor)</li> </ul> |
| P2118   | ETC MOT-B1<br>[Throttle control motor (bank 1)<br>circuit short] |   |   |

### DTC CONFIRMATION PROCEDURE

#### 1. PRECONDITIONING

If DTC Confirmation Procedure has been previously conducted, always perform the following procedure before conducting the next test.

1. Turn ignition switch OFF and wait at least 10 seconds.
2. Turn ignition switch ON.
3. Turn ignition switch OFF and wait at least 10 seconds.

>> GO TO 2.

#### 2. PERFORM DTC CONFIRMATION PROCEDURE

1. Turn ignition switch ON and wait at least 2 seconds.
2. Start engine and let it idle for 5 seconds.
3. Check DTC.

Is DTC detected?

- YES >> Proceed to [EC-1427, "Diagnosis Procedure"](#).  
 NO >> INSPECTION END

### Diagnosis Procedure

INFOID:000000007187693

#### 1. CHECK THROTTLE CONTROL MOTOR OUTPUT SIGNAL CIRCUIT FOR OPEN AND SHORT

1. Disconnect electric throttle control actuator harness connector.
2. Disconnect ECM harness connector.
3. Check the continuity between electric throttle control actuator harness connector and ECM harness connector.

| DTC   | Electric throttle control actuator |           |          | ECM       |          | Continuity  |
|-------|------------------------------------|-----------|----------|-----------|----------|-------------|
|       | Bank                               | Connector | Terminal | Connector | Terminal |             |
| P1233 | 2                                  | F64       | 5        | F111      | 62       | Not existed |
|       |                                    |           |          |           | 58       | Existed     |
|       |                                    |           | 6        |           | 62       | Existed     |
|       |                                    |           |          |           | 58       | Not existed |
| P2101 | 1                                  | F66       | 5        | F111      | 57       | Not existed |
|       |                                    |           |          |           | 63       | Existed     |
|       |                                    |           | 6        |           | 57       | Existed     |
|       |                                    |           |          |           | 63       | Not existed |

4. Also check harness for short to ground and short to power.

Is the inspection result normal?

# P1236, P2118 THROTTLE CONTROL MOTOR

[VK56VD FOR USA AND CANADA]

## < DTC/CIRCUIT DIAGNOSIS >

- YES >> GO TO 2.  
NO >> Repair or replace malfunctioning part.

### 2.CHECK THROTTLE CONTROL MOTOR

Refer to [EC-1425, "Component Inspection \(Electric Throttle Control Motor\)"](#).

Is the inspection result normal?

- YES >> GO TO 3.  
NO >> GO TO 4.

### 3.CHECK INTERMITTENT INCIDENT

Refer to [GI-44, "Intermittent Incident"](#).

Is the inspection result normal?

- YES >> GO TO 4.  
NO >> Repair or replace harness or connectors.

### 4.REPLACE ELECTRIC THROTTLE CONTROL ACTUATOR

Replace malfunctioning electric throttle control actuator. Refer to [EM-191, "Removal and Installation"](#).

>> INSPECTION END

## Component Inspection (Electric Throttle Control Motor)

INFOID:000000007187694

### 1.CHECK THROTTLE CONTROL MOTOR

1. Turn ignition switch OFF.
2. Disconnect electric throttle control actuator harness connector.
3. Check resistance between electric throttle control actuator terminals as per the following.

| Electric throttle control actuator |           |           | Resistance                               |
|------------------------------------|-----------|-----------|--|
| Bank                               | Connector | Terminals |  |
| 1                                  | F66       | 5 and 6   | Approx. 1 - 15 $\Omega$ [at 25°C (77°F)] |
| 2                                  | F64       | 5 and 6   |  |

Is the inspection result normal?

- YES >> INSPECTION END  
NO >> GO TO 2.

### 2.REPLACE ELECTRIC THROTTLE CONTROL ACTUATOR

Replace malfunctioning electric throttle control actuator. Refer to [EM-191, "Removal and Installation"](#).

>> INSPECTION END

# P1238, P2119 ELECTRIC THROTTLE CONTROL ACTUATOR

< DTC/CIRCUIT DIAGNOSIS >

[VK56VD FOR USA AND CANADA]

## P1238, P2119 ELECTRIC THROTTLE CONTROL ACTUATOR

### DTC Logic

INFOID:000000007187695

### DTC DETECTION LOGIC

| DTC No. | Trouble diagnosis name<br>(Trouble diagnosis content)        | DTC detecting condition |   | Possible cause                     |
|---------|--|-------------------------|---|------------------------------------|
| P1238   | ETC ACTR-B2<br>[Electric throttle control actuator (bank 2)] | A)                      | Electric throttle control actuator does not function properly due to the return spring malfunction. | Electric throttle control actuator |
|         |  | B)                      | Throttle valve opening angle in fail-safe mode is not in specified range.                           |                                    |
|         |  | C)                      | ECM detect that the throttle valve is stuck open.   |                                    |
| P2119   | ETC ACTR-B1<br>[Electric throttle control actuator (bank 1)] | A)                      | Electric throttle control actuator does not function properly due to the return spring malfunction. | Electric throttle control actuator |
|         |  | B)                      | Throttle valve opening angle in fail-safe mode is not in specified range.                           |                                    |
|         |  | C)                      | ECM detects that the throttle valve is stuck open.  |                                    |

### DTC CONFIRMATION PROCEDURE

#### 1. PRECONDITIONING

1. Turn ignition switch OFF and wait at least 10 seconds.
2. Turn ignition switch ON.
3. Turn ignition switch OFF and wait at least 10 seconds.

#### TESTING CONDITION:

Before performing the following procedure, confirm that battery voltage is 8 V or more at idle.

>> GO TO 2.

#### 2. PERFORM DTC CONFIRMATION PROCEDURE FOR MALFUNCTION A AND B

1. Turn ignition switch ON and wait at least 1 second.
2. Shift selector lever position to D and wait at least 3 seconds.
3. Shift selector lever position to P.
4. Turn ignition switch OFF and wait at least 10 seconds.
5. Turn ignition switch ON and wait at least 1 second.
6. Shift selector lever position to D and wait at least 3 seconds.
7. Shift selector lever position to P.
8. Turn ignition switch OFF, wait at least 10 seconds, and then turn ON.
9. Check DTC.

#### Is DTC detected?

- YES >> Proceed to [EC-1429, "Diagnosis Procedure"](#).  
NO >> GO TO 3.

#### 3. PERFORM DTC CONFIRMATION PROCEDURE FOR MALFUNCTION C

1. Turn ignition switch ON and wait at least 1 second.
2. Shift selector lever position to D and wait at least 3 seconds.
3. Shift selector lever position to P.
4. Start engine and let it idle for 3 seconds.
5. Check DTC.

#### Is DTC detected?

- YES >> Proceed to [EC-1429, "Diagnosis Procedure"](#).  
NO >> INSPECTION END

### Diagnosis Procedure

INFOID:000000007187696

#### 1. CHECK ELECTRIC THROTTLE CONTROL ACTUATOR VISUALLY

## P1238, P2119 ELECTRIC THROTTLE CONTROL ACTUATOR

< DTC/CIRCUIT DIAGNOSIS >

[VK56VD FOR USA AND CANADA]

---

1. Turn ignition switch OFF.
2. Remove the intake air duct. Refer to [EM-184, "Exploded View"](#).
3. Check that no foreign matter is caught between the throttle valve and the housing.

Is the inspection result normal?

YES >> GO TO 2.

NO >> Remove the foreign matter and clean the electric throttle control actuator inside, and then perform throttle valve closed position learning. Refer to [EC-1121, "Work Procedure"](#).

### **2. REPLACE ELECTRIC THROTTLE CONTROL ACTUATOR**

---

Replace malfunctioning electric throttle control actuator. Refer to [EM-191, "Removal and Installation"](#).

>> INSPECTION END

# P1239, P2135 TP SENSOR

< DTC/CIRCUIT DIAGNOSIS >

[VK56VD FOR USA AND CANADA]

## P1239, P2135 TP SENSOR

### DTC Logic

INFOID:000000007187697

#### DTC DETECTION LOGIC

##### NOTE:

If DTC P1239 or P2135 is displayed with DTC P0643, first perform the trouble diagnosis for DTC P0643. Refer to [EC-1389, "DTC Logic"](#).

| DTC No. | Trouble diagnosis name<br>(Trouble diagnosis content)                                 | DTC detecting condition   | Possible cause  |
|---------|---|---|---|
| P1239   | TP SENSOR-B2<br>[Throttle position sensor<br>(bank 2) circuit range/per-<br>formance] | Rationally incorrect voltage is sent to<br>ECM compared with the signals from TP<br>sensor 1 and TP sensor 2. | <ul style="list-style-type: none"><li>• Harness or connector<br/>(Throttle position sensor 1 or 2 circuit is open<br/>or shorted.)</li><li>• Electric throttle control actuator<br/>(Throttle position sensor 1 or 2)</li></ul> |
| P2135   | TP SENSOR-B1<br>[Throttle position sensor<br>(bank 1) circuit range/per-<br>formance] |   |   |

#### DTC CONFIRMATION PROCEDURE

##### 1. PRECONDITIONING

1. Turn ignition switch OFF and wait at least 10 seconds.
2. Turn ignition switch ON.
3. Turn ignition switch OFF and wait at least 10 seconds.

##### TESTING CONDITION:

Before performing the following procedure, confirm that battery voltage is 8 V or more at idle.

>> GO TO 2.

##### 2. PERFORM DTC CONFIRMATION PROCEDURE

1. Start engine and let it idle for 1 second.
2. Check DTC.

##### Is DTC detected?

- YES >> Proceed to [EC-1431, "Diagnosis Procedure"](#).  
NO >> INSPECTION END

#### Diagnosis Procedure

INFOID:000000007187698

##### 1. CHECK THROTTLE POSITION SENSOR POWER SUPPLY CIRCUIT-I

1. Disconnect electric throttle control actuator harness connector.
2. Turn ignition switch ON.
3. Check the voltage between electric throttle control actuator harness connector and ground.

| DTC   | Electric throttle control actuator |           |          | Ground | Voltage (V) |
|-------|------------------------------------|-----------|----------|--------|-------------|
|       | Bank                               | Connector | Terminal |        |             |
| P1239 | 2                                  | F64       | 2        | Ground | Approx. 5   |
| P2135 | 1                                  | F66       | 2        |        |             |

##### Is the inspection result normal?

- YES >> GO TO 2.  
NO >> Repair open circuit, short to ground or short to power in harness or connectors.

##### 2. CHECK THROTTLE POSITION SENSOR GROUND CIRCUIT FOR OPEN AND SHORT

1. Turn ignition switch OFF.
2. Disconnect ECM harness connector.

# P1239, P2135 TP SENSOR

[VK56VD FOR USA AND CANADA]

## < DTC/CIRCUIT DIAGNOSIS >

3. Check the continuity between electric throttle control actuator harness connector and ECM harness connector.

| DTC   | Electric throttle control actuator |           |          | ECM       |          | Continuity |
|-------|------------------------------------|-----------|----------|-----------|----------|------------|
|       | Bank                               | Connector | Terminal | Connector | Terminal |            |
| P1239 | 2                                  | F64       | 4        | F111      | 69       | Existed    |
| P2135 | 1                                  | F66       | 4        |           | 97       |            |

4. Also check harness for short to ground and short to power.

Is the inspection result normal?

YES >> GO TO 3.

NO >> Repair open circuit, short to ground or short to power in harness or connectors.

## 3.CHECK THROTTLE POSITION SENSOR INPUT SIGNAL CIRCUIT FOR OPEN AND SHORT

1. Check the continuity between electric throttle control actuator harness connector and ECM harness connector.

| DTC   | Electric throttle control actuator |           |          | ECM       |          | Continuity |
|-------|------------------------------------|-----------|----------|-----------|----------|------------|
|       | Bank                               | Connector | Terminal | Connector | Terminal |            |
| P1239 | 2                                  | F64       | 1        | F111      | 71       | Existed    |
|       |                                    |           | 3        |           | 89       |            |
| P2135 | 1                                  | F66       | 1        |           | 91       |            |
|       |                                    |           | 3        |           | 79       |            |

2. Also check harness for short to ground and short to power.

Is the inspection result normal?

YES >> GO TO 4.

NO >> Repair open circuit, short to ground or short to power in harness or connectors.

## 4.CHECK THROTTLE POSITION SENSOR

Refer to [EC-1432, "Component Inspection \(Throttle Position Sensor\)"](#).

Is the inspection result normal?

YES >> GO TO 6.

NO >> GO TO 5.

## 5.REPLACE ELECTRIC THROTTLE CONTROL ACTUATOR

Replace malfunctioning electric throttle control actuator. Refer to [EM-191, "Removal and Installation"](#).

>> INSPECTION END

## 6.CHECK INTERMITTENT INCIDENT

Refer to [GI-44, "Intermittent Incident"](#).

>> INSPECTION END

## Component Inspection (Throttle Position Sensor)

INFOID:000000007187699

## 1.CHECK THROTTLE POSITION SENSOR

1. Turn ignition switch OFF.
2. Reconnect all harness connectors disconnected.
3. Perform [EC-1121, "Work Procedure"](#).
4. Turn ignition switch ON.
5. Set selector lever position to D.
6. Check the voltage between ECM harness connector terminals under the following conditions.



# P1239, P2135 TP SENSOR

< DTC/CIRCUIT DIAGNOSIS >

[VK56VD FOR USA AND CANADA]

| ECM       |                              |          | Condition                          | Voltage (V)    |
|-----------|------------------------------|----------|------------------------------------|----------------|
| Connector | +                            | -        |                                    |                |
|           | Terminal                     | Terminal |                                    |                |
| F111      | 91<br>[TP sensor 1 (bank 1)] | 97       | Accelerator pedal: Fully released  | More than 0.36 |
|           |                              |          | Accelerator pedal: Fully depressed | Less than 4.75 |
|           | 71<br>[TP sensor 1 (bank 2)] | 69       | Accelerator pedal: Fully released  | More than 0.36 |
|           |                              |          | Accelerator pedal: Fully depressed | Less than 4.75 |
|           | 79<br>[TP sensor 2 (bank 1)] | 97       | Accelerator pedal: Fully released  | Less than 4.75 |
|           |                              |          | Accelerator pedal: Fully depressed | More than 0.36 |
|           | 89<br>[TP sensor 2 (bank 2)] | 69       | Accelerator pedal: Fully released  | Less than 4.75 |
|           |                              |          | Accelerator pedal: Fully depressed | More than 0.36 |

Is the inspection result normal?

YES >> INSPECTION END

NO >> GO TO 2.

## 2. REPLACE ELECTRIC THROTTLE CONTROL ACTUATOR

Replace malfunctioning electric throttle control actuator. Refer to [EM-191. "Removal and Installation"](#).

>> INSPECTION END

A  
EC  
C  
D  
E  
F  
G  
H  
I  
J  
K  
L  
M  
N  
O  
P

# P1423, P1424 COLD START CONTROL

< DTC/CIRCUIT DIAGNOSIS >

[VK56VD FOR USA AND CANADA]

## P1423, P1424 COLD START CONTROL

### Description

INFOID:000000007187700

ECM controls fuel injection timing and fuel injection quantity when engine is started with the engine cold. This control promotes the activation of three way catalyst by heating the catalyst and reduces emissions.

### DTC Logic

INFOID:000000007187701

### DTC DETECTION LOGIC

#### NOTE:

- If DTC P1423 or P1424 is displayed with other DTC, first perform the trouble diagnosis for other DTC.

| DTC No. | Trouble diagnosis name<br>(Trouble diagnosis content)                     | DTC detecting condition   | Possible cause |
|---------|---|---|----------------|
| P1423   | COLD START CONTROL<br>(Cold start emission reduction strategy monitoring) | ECM does not control fuel injection timing properly when engine is started with the engine cold.        | ECM            |
| P1424   | COLD START CONTROL<br>(Cold start emission reduction strategy monitoring) | ECM does not control fuel injection quantity properly when engine is started with with the engine cold. |                |

### DTC CONFIRMATION PROCEDURE

#### 1. PRECONDITIONING

If DTC Confirmation Procedure has been previously conducted, always perform the following procedure before conducting the next test.

1. Turn ignition switch OFF and wait at least 10 seconds.
2. Turn ignition switch ON.
3. Turn ignition switch OFF and wait at least 10 seconds.

>> GO TO 2.

#### 2. PERFORM DTC CONFIRMATION PROCEDURE

##### Ⓜ WITH CONSULT

1. Turn ignition switch OFF and wait at least 10 seconds.
2. Turn ignition switch ON.
3. Select "DATA MONITOR" mode with CONSULT.
4. Check that "COOLAN TEMP/S".
  - If it is between 5°C (41°F) and 40°C (104°F) go to the following steps.
  - If it is below 5°C (41°F) warm engine up to more than 5°C (41°F) and retry from step 1.
  - If it is above 40°C (104°F) cool engine down to less than 40°C (104°F) and retry from step 1.
5. Start engine and let it idle for 5 minutes.
6. Check 1st trip DTC.

##### Ⓜ WITH GST

Follow the procedure "With CONSULT" above.

#### Is 1st trip DTC detected?

- YES >> Proceed to [EC-1434, "Diagnosis Procedure"](#).  
NO >> INSPECTION END

### Diagnosis Procedure

INFOID:000000007187702

#### 1. INSPECTION START

1. Turn ignition switch ON.
2. Erase DTC.
3. Perform DTC confirmation procedure. Refer to [EC-1434, "DTC Logic"](#).
4. Check 1st trip DTC.

# P1423, P1424 COLD START CONTROL

< DTC/CIRCUIT DIAGNOSIS >

[VK56VD FOR USA AND CANADA]

Is the 1st trip DTC P1423 or P1424 displayed again?

YES >> GO TO 2.

NO >> INSPECTION END

## 2.REPLACE ECM

Replace ECM. Refer to [EC-1553. "Removal and Installation"](#).

>> INSPECTION END

A

EC

C

D

E

F

G

H

I

J

K

L

M

N

O

P

# P1550 BATTERY CURRENT SENSOR

< DTC/CIRCUIT DIAGNOSIS >

[VK56VD FOR USA AND CANADA]

## P1550 BATTERY CURRENT SENSOR

### DTC Logic

INFOID:000000007187703

### DTC DETECTION LOGIC

| DTC No. | Trouble diagnosis name<br>(Trouble diagnosis content)                    | DTC detecting condition  | Possible cause  |
|---------|--|--|---|
| P1550   | BAT CURRENT SENSOR<br>(Battery current sensor circuit range/performance) | The output voltage of the battery current sensor remains within the specified range while engine is running. | <ul style="list-style-type: none"><li>• Harness or connectors<br/>(Battery current sensor circuit is shorted.)<br/>(Crankshaft position sensor circuit is open or shorted.)<br/>[Camshaft position sensor (bank 1) circuit is shorted.]<br/>(Accelerator pedal position sensor 2 circuit is shorted.)<br/>(EVAP control system pressure sensor circuit is shorted.)<br/>(Refrigerant pressure sensor circuit is shorted.)</li><li>• Battery current sensor</li><li>• Crankshaft position sensor</li><li>• Camshaft position sensor (bank 1)</li><li>• Accelerator pedal position sensor 2</li><li>• EVAP control system pressure sensor</li><li>• Refrigerant pressure sensor</li></ul> |

### DTC CONFIRMATION PROCEDURE

#### 1. PRECONDITIONING

1. Turn ignition switch OFF and wait at least 10 seconds.
2. Turn ignition switch ON.
3. Turn ignition switch OFF and wait at least 10 seconds.

#### TESTING CONDITION:

Before performing the following procedure, confirm that battery voltage is 8 V or more at idle.

>> GO TO 2.

#### 2. PERFORM DTC CONFIRMATION PROCEDURE

1. Start engine and let it idle for at least 10 seconds.
2. Check 1st trip DTC.

#### Is 1st trip DTC detected?

- YES >> Proceed to [EC-1436, "Diagnosis Procedure"](#).  
NO >> INSPECTION END

### Diagnosis Procedure

INFOID:000000007187704

#### 1. CHECK BATTERY CURRENT SENSOR POWER SUPPLY CIRCUIT-I

1. Disconnect battery current sensor harness connector.
2. Turn ignition switch ON.
3. Check the voltage between battery current sensor harness connector and ground.

| Battery current sensor |          | Ground | Voltage (V) |
|------------------------|----------|--------|-------------|
| Connector              | Terminal |        |             |
| E21                    | 1        | Ground | Approx. 5   |

#### Is the inspection result normal?

- YES >> GO TO 7.  
NO >> GO TO 2.

#### 2. CHECK BATTERY CURRENT SENSOR POWER SUPPLY CIRCUIT-II

1. Turn ignition switch ON.
2. Disconnect ECM harness connector.

# P1550 BATTERY CURRENT SENSOR

[VK56VD FOR USA AND CANADA]

< DTC/CIRCUIT DIAGNOSIS >

3. Check the continuity between battery current sensor harness connector and ECM harness connector.

| Battery current sensor |          | ECM       |          | Continuity |
|------------------------|----------|-----------|----------|------------|
| Connector              | Terminal | Connector | Terminal |            |
| E21                    | 1        | M160      | 133      | Existed    |

Is the inspection result normal?

YES >> GO TO 3.

NO >> Repair open circuit.

## 3.CHECK SENSOR POWER SUPPLY CIRCUIT

Check harness for short to power and short to ground, between the following terminals.

| ECM       |          | Sensor                              |           |          |
|-----------|----------|-------------------------------------|-----------|----------|
| Connector | Terminal | Name                                | Connector | Terminal |
| F111      | 76       | CKP sensor                          | F2        | 1        |
|           | 77       | Camshaft position sensor (bank 1)   | F84       | 1        |
| M160      | 133      | Battery current sensor              | E21       | 1        |
|           | 133      | EVAP control system pressure sensor | B73       | 3        |
|           | 133      | Refrigerant pressure sensor         | E77       | 3        |
|           | 131      | APP sensor 2 (Without ICC)          | M9        | 6        |
|           | 131      | APP sensor 2 (With ICC)             | M153      | 3        |

Is the inspection result normal?

YES >> GO TO 4.

NO >> Repair short to ground or short to power in harness or connectors.

## 4.CHECK COMPONENTS

Check the following.

- Camshaft position sensor (bank 1) (Refer to [EC-1312, "Component Inspection \(Camshaft Position Sensor\)"](#).)
- CKP sensor (Refer to [EC-1307, "Component Inspection \(Crankshaft Position Sensor\)"](#).)
- EVAP control system pressure sensor (Refer to [EC-1343, "Component Inspection \(EVAP Control System Pressure Sensor\)"](#).)
- Refrigerant pressure sensor (Refer to [EC-1539, "Diagnosis Procedure"](#).)

Is the inspection result normal?

YES >> GO TO 5.

NO >> Replace malfunctioning component.

## 5.CHECK APP SENSOR

Refer to [EC-1497, "Component Inspection \(Accelerator Pedal Position Sensor\)"](#).

Is the inspection result normal?

YES >> GO TO 10.

NO >> GO TO 6.

## 6.REPLACE ACCELERATOR PEDAL ASSEMBLY

Replace accelerator pedal assembly. Refer to following.

- Models without Distance Control Assist system: [ACC-3, "MODELS WITHOUT DISTANCE CONTROL ASSIST SYSTEM : Removal and Installation"](#)
- Models with Distance Control Assist system: [ACC-4, "MODELS WITH DISTANCE CONTROL ASSIST SYSTEM : Removal and Installation"](#)

>> INSPECTION END

## 7.CHECK BATTERY CURRENT SENSOR GROUND CIRCUIT FOR OPEN AND SHORT

1. Turn ignition switch OFF.

# P1550 BATTERY CURRENT SENSOR

[VK56VD FOR USA AND CANADA]

## < DTC/CIRCUIT DIAGNOSIS >

2. Disconnect ECM harness connector.
3. Check the continuity between battery current sensor harness connector and ECM harness connector.

| Battery current sensor |          | ECM       |          | Continuity |
|------------------------|----------|-----------|----------|------------|
| Connector              | Terminal | Connector | Terminal |            |
| E21                    | 3        | M160      | 150      | Existed    |

4. Also check harness for short to ground and short to power.

Is the inspection result normal?

YES >> GO TO 8.

NO >> Repair open circuit, short to ground or short to power in harness or connectors.

## 8. CHECK BATTERY CURRENT SENSOR INPUT SIGNAL CIRCUIT FOR OPEN AND SHORT

1. Check the continuity between battery current sensor harness connector and ECM harness connector.

| Battery current sensor |          | ECM       |          | Continuity |
|------------------------|----------|-----------|----------|------------|
| Connector              | Terminal | Connector | Terminal |            |
| E21                    | 4        | M160      | 138      | Existed    |

2. Also check harness for short to ground and short to power.

Is the inspection result normal?

YES >> GO TO 9.

NO >> Repair open circuit, short to ground or short to power in harness or connectors.

## 9. CHECK BATTERY CURRENT SENSOR

Refer to [EC-1438, "Component Inspection \(Battery Current Sensor\)"](#).

Is the inspection result normal?

YES >> GO TO 10.

NO >> Replace battery negative cable assembly.

## 10. CHECK INTERMITTENT INCIDENT

Refer to [GI-44, "Intermittent Incident"](#).

>> INSPECTION END

## Component Inspection (Battery Current Sensor)

INFOID:000000007187705

### 1. CHECK BATTERY CURRENT SENSOR

1. Turn ignition switch OFF.
2. Reconnect harness connectors disconnected.
3. Disconnect battery negative cable.
4. Install jumper cable between battery negative terminal and body ground.
5. Turn ignition switch ON.
6. Check the voltage between ECM harness connector terminals under the following conditions.

| Connector | ECM                                    |          | Voltage (V) |
|-----------|--|----------|-------------|
|           | +                                      | -        |             |
|           | Terminal                               | Terminal |             |
| M160      | 138<br>(Battery current sensor signal) | 150      | Approx. 2.5 |

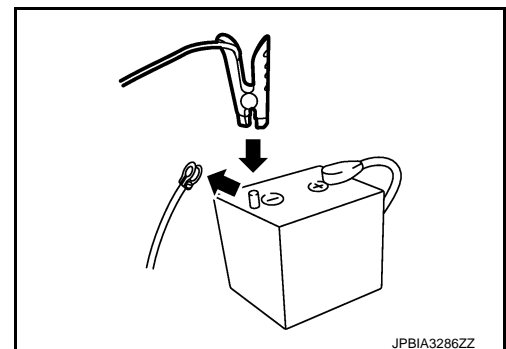

Before measuring the terminal voltage, confirm that the battery is fully charged. Refer to [PG-135, "How to Handle Battery"](#).

Is the inspection result normal?

YES >> INSPECTION END

# P1550 BATTERY CURRENT SENSOR

< DTC/CIRCUIT DIAGNOSIS >

[VK56VD FOR USA AND CANADA]

NO >> Replace battery negative cable assembly.

A

**EC**

C

D

E

F

G

H

I

J

K

L

M

N

O

P

# P1551, P1552 BATTERY CURRENT SENSOR

< DTC/CIRCUIT DIAGNOSIS >

[VK56VD FOR USA AND CANADA]

## P1551, P1552 BATTERY CURRENT SENSOR

### DTC Logic

INFOID:000000007187706

### DTC DETECTION LOGIC

| DTC No. | Trouble diagnosis name<br>(Trouble diagnosis content)                | DTC detecting condition  | Possible cause  |
|---------|--|--|---|
| P1551   | BAT CURRENT SENSOR<br>(Battery current sensor circuit<br>low input)  | An excessively low voltage from<br>the sensor is sent to ECM.  | <ul style="list-style-type: none"><li>• Harness or connectors<br/>(Battery current sensor circuit is shorted.)<br/>(Crankshaft position sensor circuit is open or<br/>shorted.)<br/>[Camshaft position sensor (bank 1) circuit is<br/>shorted.]<br/>(Accelerator pedal position sensor 2 circuit is<br/>shorted.)<br/>(EVAP control system pressure sensor circuit is<br/>shorted.)<br/>(Refrigerant pressure sensor circuit is shorted.)</li><li>• Battery current sensor</li><li>• Crankshaft position sensor</li><li>• Camshaft position sensor (bank 1)</li><li>• Accelerator pedal position sensor 2</li><li>• EVAP control system pressure sensor</li><li>• Refrigerant pressure sensor</li></ul> |
| P1552   | Battery current sensor circuit<br>high input<br>(BAT CURRENT SENSOR) | An excessively high voltage from<br>the sensor is sent to ECM. |   |

### DTC CONFIRMATION PROCEDURE

#### 1. PRECONDITIONING

1. Turn ignition switch OFF and wait at least 10 seconds.
2. Turn ignition switch ON.
3. Turn ignition switch OFF and wait at least 10 seconds.

#### TESTING CONDITION:

Before performing the following procedure, confirm that battery voltage is 8 V or more with ignition switch ON

>> GO TO 2.

#### 2. PERFORM DTC CONFIRMATION PROCEDURE

1. Turn ignition switch ON and wait at least 10 seconds.
2. Check 1st trip DTC.

#### Is 1st trip DTC detected?

- YES >> Proceed to [EC-1440, "Diagnosis Procedure"](#).  
NO >> INSPECTION END

### Diagnosis Procedure

INFOID:000000007187707

#### 1. CHECK BATTERY CURRENT SENSOR POWER SUPPLY CIRCUIT-I

1. Disconnect battery current sensor harness connector.
2. Turn ignition switch ON.
3. Check the voltage between battery current sensor harness connector and ground.

| Battery current sensor |          | Ground | Voltage (V) |
|------------------------|----------|--------|-------------|
| Connector              | Terminal |        |             |
| E21                    | 1        | Ground | Approx. 5   |

#### Is the inspection result normal?

- YES >> GO TO 7.  
NO >> GO TO 2.



# P1551, P1552 BATTERY CURRENT SENSOR

< DTC/CIRCUIT DIAGNOSIS >

[VK56VD FOR USA AND CANADA]

## 2. CHECK BATTERY CURRENT SENSOR POWER SUPPLY CIRCUIT-II

1. Turn ignition switch ON.
2. Disconnect ECM harness connector.
3. Check the continuity between battery current sensor harness connector and ECM harness connector.

| Battery current sensor |          | ECM       |          | Continuity |
|------------------------|----------|-----------|----------|------------|
| Connector              | Terminal | Connector | Terminal |            |
| E21                    | 1        | M160      | 133      | Existed    |

Is the inspection result normal?

YES >> GO TO 3.

NO >> Repair open circuit.

## 3. CHECK SENSOR POWER SUPPLY CIRCUIT

Check harness for short to power and short to ground, between the following terminals.

| ECM       |          | Sensor                              |           |          |
|-----------|----------|-------------------------------------|-----------|----------|
| Connector | Terminal | Name                                | Connector | Terminal |
| F111      | 76       | CKP sensor                          | F2        | 1        |
|           | 77       | Camshaft position sensor (bank 1)   | F84       | 1        |
| M160      | 133      | Battery current sensor              | E21       | 1        |
|           | 133      | EVAP control system pressure sensor | B73       | 3        |
|           | 133      | Refrigerant pressure sensor         | E77       | 3        |
|           | 131      | APP sensor 2 (Without ICC)          | M9        | 6        |
|           | 131      | APP sensor 2 (With ICC)             | M153      | 3        |

Is the inspection result normal?

YES >> GO TO 4.

NO >> Repair short to ground or short to power in harness or connectors.

## 4. CHECK COMPONENTS

Check the following.

- Camshaft position sensor (bank 1) (Refer to [EC-1312, "Component Inspection \(Camshaft Position Sensor\)"](#).)
- CKP sensor (Refer to [EC-1307, "Component Inspection \(Crankshaft Position Sensor\)"](#).)
- EVAP control system pressure sensor (Refer to [EC-1343, "Component Inspection \(EVAP Control System Pressure Sensor\)"](#).)
- Refrigerant pressure sensor (Refer to [EC-1539, "Diagnosis Procedure"](#).)

Is the inspection result normal?

YES >> GO TO 5.

NO >> Replace malfunctioning component.

## 5. CHECK APP SENSOR

Refer to [EC-1497, "Component Inspection \(Accelerator Pedal Position Sensor\)"](#).

Is the inspection result normal?

YES >> GO TO 10.

NO >> GO TO 6.

## 6. REPLACE ACCELERATOR PEDAL ASSEMBLY

Replace accelerator pedal assembly. Refer to following.

- Models without Distance Control Assist system: [ACC-3, "MODELS WITHOUT DISTANCE CONTROL ASSIST SYSTEM : Removal and Installation"](#)
- Models with Distance Control Assist system: [ACC-4, "MODELS WITH DISTANCE CONTROL ASSIST SYSTEM : Removal and Installation"](#)

# P1551, P1552 BATTERY CURRENT SENSOR

< DTC/CIRCUIT DIAGNOSIS >

[VK56VD FOR USA AND CANADA]

>> INSPECTION END

## 7. CHECK BATTERY CURRENT SENSOR GROUND CIRCUIT FOR OPEN AND SHORT

1. Turn ignition switch OFF.
2. Disconnect ECM harness connector.
3. Check the continuity between battery current sensor harness connector and ECM harness connector.

| Battery current sensor |          | ECM       |          | Continuity |
|------------------------|----------|-----------|----------|------------|
| Connector              | Terminal | Connector | Terminal |            |
| E21                    | 3        | M160      | 150      | Existed    |

4. Also check harness for short to ground and short to power.

Is the inspection result normal?

YES >> GO TO 8.

NO >> Repair open circuit, short to ground or short to power in harness or connectors.

## 8. CHECK BATTERY CURRENT SENSOR INPUT SIGNAL CIRCUIT FOR OPEN AND SHORT

1. Check the continuity between battery current sensor harness connector and ECM harness connector.

| Battery current sensor |          | ECM       |          | Continuity |
|------------------------|----------|-----------|----------|------------|
| Connector              | Terminal | Connector | Terminal |            |
| E21                    | 4        | M160      | 138      | Existed    |

2. Also check harness for short to ground and short to power.

Is the inspection result normal?

YES >> GO TO 9.

NO >> Repair open circuit, short to ground or short to power in harness or connectors.

## 9. CHECK BATTERY CURRENT SENSOR

Refer to [EC-1442, "Component Inspection \(Battery Current Sensor\)"](#).

Is the inspection result normal?

YES >> GO TO 10.

NO >> Replace battery negative cable assembly.

## 10. CHECK INTERMITTENT INCIDENT

Refer to [GI-44, "Intermittent Incident"](#).

>> INSPECTION END

## Component Inspection (Battery Current Sensor)

INFOID:000000007187708

### 1. CHECK BATTERY CURRENT SENSOR

1. Turn ignition switch OFF.
2. Reconnect harness connectors disconnected.
3. Disconnect battery negative cable.
4. Install jumper cable between battery negative terminal and body ground.
5. Turn ignition switch ON.
6. Check the voltage between ECM harness connector terminals under the following conditions.

| Connector | ECM                                    |          | Voltage (V) |
|-----------|--|----------|-------------|
|           | +                                      | -        |             |
|           | Terminal                               | Terminal |             |
| M160      | 138<br>(Battery current sensor signal) | 150      | Approx. 2.5 |

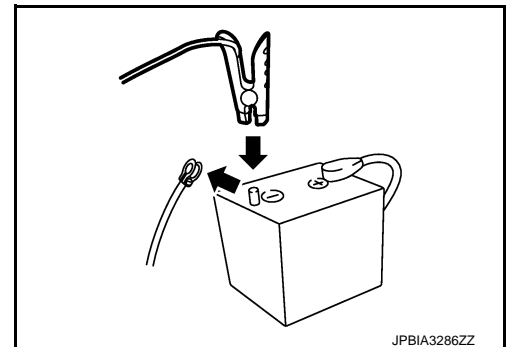

JPBIA3286ZZ

# P1551, P1552 BATTERY CURRENT SENSOR

< DTC/CIRCUIT DIAGNOSIS >

[VK56VD FOR USA AND CANADA]

Before measuring the terminal voltage, confirm that the battery is fully charged. Refer to [PG-135, "How to Handle Battery"](#).

Is the inspection result normal?

YES >> INSPECTION END

NO >> Replace battery negative cable assembly.

A

EC

C

D

E

F

G

H

I

J

K

L

M

N

O

P

# P1553 BATTERY CURRENT SENSOR

< DTC/CIRCUIT DIAGNOSIS >

[VK56VD FOR USA AND CANADA]

## P1553 BATTERY CURRENT SENSOR

### DTC Logic

INFOID:000000007187709

### DTC DETECTION LOGIC

| DTC No. | Trouble diagnosis name<br>(Trouble diagnosis content)      | DTC detecting condition  | Possible cause  |
|---------|--|--|---|
| P1553   | BAT CURRENT SENSOR<br>(Battery current sensor performance) | The signal voltage transmitted from the sensor to ECM is higher than the amount of the maximum power generation. | <ul style="list-style-type: none"> <li>• Harness or connectors<br/>(Battery current sensor circuit is shorted.)<br/>(Crankshaft position sensor circuit is open or shorted.)<br/>[Camshaft position sensor (bank 1) circuit is shorted.]<br/>(Accelerator pedal position sensor 2 circuit is shorted.)<br/>(EVAP control system pressure sensor circuit is shorted.)<br/>(Refrigerant pressure sensor circuit is shorted.)</li> <li>• Battery current sensor</li> <li>• Crankshaft position sensor</li> <li>• Camshaft position sensor (bank 1)</li> <li>• Accelerator pedal position sensor 2</li> <li>• EVAP control system pressure sensor</li> <li>• Refrigerant pressure sensor</li> </ul> |

### DTC CONFIRMATION PROCEDURE

#### 1. PRECONDITIONING

1. Turn ignition switch OFF and wait at least 10 seconds.
2. Turn ignition switch ON.
3. Turn ignition switch OFF and wait at least 10 seconds.

#### TESTING CONDITION:

Before performing the following procedure, confirm that battery voltage is 8 V or more at idle.

>> GO TO 2.

#### 2. PERFORM DTC CONFIRMATION PROCEDURE

1. Start engine and let it idle for least 10 seconds.
2. Check 1st trip DTC.

#### Is 1st trip DTC detected?

- YES >> Proceed to [EC-1444, "Diagnosis Procedure"](#).  
 NO >> INSPECTION END

### Diagnosis Procedure

INFOID:000000007187710

#### 1. CHECK BATTERY CURRENT SENSOR POWER SUPPLY CIRCUIT-I

1. Disconnect battery current sensor harness connector.
2. Turn ignition switch ON.
3. Check the voltage between battery current sensor harness connector and ground.

| Battery current sensor |          | Ground | Voltage (V) |
|------------------------|----------|--------|-------------|
| Connector              | Terminal |        |             |
| E21                    | 1        | Ground | Approx. 5   |

#### Is the inspection result normal?

- YES >> GO TO 7.  
 NO >> GO TO 2.

#### 2. CHECK BATTERY CURRENT SENSOR POWER SUPPLY CIRCUIT-II

# P1553 BATTERY CURRENT SENSOR

[VK56VD FOR USA AND CANADA]

## < DTC/CIRCUIT DIAGNOSIS >

1. Turn ignition switch ON.
2. Disconnect ECM harness connector.
3. Check the continuity between battery current sensor harness connector and ECM harness connector.

| Battery current sensor |          | ECM       |          | Continuity |
|------------------------|----------|-----------|----------|------------|
| Connector              | Terminal | Connector | Terminal |            |
| E21                    | 1        | M160      | 133      | Existed    |

Is the inspection result normal?

YES >> GO TO 31

NO >> Repair open circuit.

## 3.CHECK SENSOR POWER SUPPLY CIRCUIT

Check harness for short to power and short to ground, between the following terminals.

| ECM       |          | Sensor                              |           |          |
|-----------|----------|-------------------------------------|-----------|----------|
| Connector | Terminal | Name                                | Connector | Terminal |
| F111      | 76       | CKP sensor                          | F2        | 1        |
|           | 77       | Camshaft position sensor (bank 1)   | F84       | 1        |
| M160      | 133      | Battery current sensor              | E21       | 1        |
|           | 133      | EVAP control system pressure sensor | B73       | 3        |
|           | 133      | Refrigerant pressure sensor         | E77       | 3        |
|           | 131      | APP sensor 2 (Without ICC)          | M9        | 6        |
|           | 131      | APP sensor 2 (With ICC)             | M153      | 3        |

Is the inspection result normal?

YES >> GO TO 4.

NO >> Repair short to ground or short to power in harness or connectors.

## 4.CHECK COMPONENTS

Check the following.

- Camshaft position sensor (bank 1) (Refer to [EC-1312, "Component Inspection \(Camshaft Position Sensor\)"](#).)
- CKP sensor (Refer to [EC-1307, "Component Inspection \(Crankshaft Position Sensor\)"](#).)
- EVAP control system pressure sensor (Refer to [EC-1343, "Component Inspection \(EVAP Control System Pressure Sensor\)"](#).)
- Refrigerant pressure sensor (Refer to [EC-1539, "Diagnosis Procedure"](#).)

Is the inspection result normal?

YES >> GO TO 5.

NO >> Replace malfunctioning component.

## 5.CHECK APP SENSOR

Refer to [EC-1497, "Component Inspection \(Accelerator Pedal Position Sensor\)"](#).

Is the inspection result normal?

YES >> GO TO 10.

NO >> GO TO 6.

## 6.REPLACE ACCELERATOR PEDAL ASSEMBLY

Replace accelerator pedal assembly.

- Models without Distance Control Assist system: [ACC-3, "MODELS WITHOUT DISTANCE CONTROL ASSIST SYSTEM : Removal and Installation"](#)
- Models with Distance Control Assist system: [ACC-4, "MODELS WITH DISTANCE CONTROL ASSIST SYSTEM : Removal and Installation"](#)

>> INSPECTION END

# P1553 BATTERY CURRENT SENSOR

< DTC/CIRCUIT DIAGNOSIS >

[VK56VD FOR USA AND CANADA]

## 7. CHECK BATTERY CURRENT SENSOR GROUND CIRCUIT FOR OPEN AND SHORT

1. Turn ignition switch OFF.
2. Disconnect ECM harness connector.
3. Check the continuity between battery current sensor harness connector and ECM harness connector.

| Battery current sensor |          | ECM       |          | Continuity |
|------------------------|----------|-----------|----------|------------|
| Connector              | Terminal | Connector | Terminal |            |
| E21                    | 3        | M160      | 150      | Existed    |

4. Also check harness for short to ground and short to power.

Is the inspection result normal?

YES >> GO TO 8.

NO >> Repair open circuit, short to ground or short to power in harness or connectors.

## 8. CHECK BATTERY CURRENT SENSOR INPUT SIGNAL CIRCUIT FOR OPEN AND SHORT

1. Check the continuity between battery current sensor harness connector and ECM harness connector.

| Battery current sensor |          | ECM       |          | Continuity |
|------------------------|----------|-----------|----------|------------|
| Connector              | Terminal | Connector | Terminal |            |
| E21                    | 4        | M160      | 138      | Existed    |

2. Also check harness for short to ground and short to power.

Is the inspection result normal?

YES >> GO TO 9.

NO >> Repair open circuit, short to ground or short to power in harness or connectors.

## 9. CHECK BATTERY CURRENT SENSOR

Refer to [EC-1446, "Component Inspection \(Battery Current Sensor\)"](#).

Is the inspection result normal?

YES >> GO TO 10.

NO >> Replace battery negative cable assembly.

## 10. CHECK INTERMITTENT INCIDENT

Refer to [GI-44, "Intermittent Incident"](#).

>> INSPECTION END

## Component Inspection (Battery Current Sensor)

INFOID:000000007187711

### 1. CHECK BATTERY CURRENT SENSOR

1. Turn ignition switch OFF.
2. Reconnect harness connectors disconnected.
3. Disconnect battery negative cable.
4. Install jumper cable between battery negative terminal and body ground.
5. Turn ignition switch ON.
6. Check the voltage between ECM harness connector terminals under the following conditions.

| Connector | ECM                                    |          | Voltage (V) |
|-----------|--|----------|-------------|
|           | +                                      | -        |             |
|           | Terminal                               | Terminal |             |
| M160      | 138<br>(Battery current sensor signal) | 150      | Approx. 2.5 |

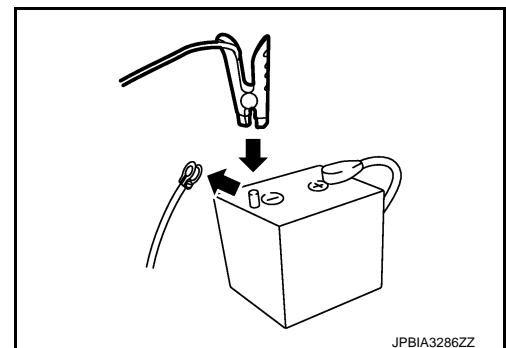

JPBIA3286ZZ

Before measuring the terminal voltage, confirm that the battery is fully charged. Refer to [PG-135, "How to Handle Battery"](#).

# P1553 BATTERY CURRENT SENSOR

< DTC/CIRCUIT DIAGNOSIS >

[VK56VD FOR USA AND CANADA]

Is the inspection result normal?

YES >> INSPECTION END

NO >> Replace battery negative cable assembly.

A

**EC**

C

D

E

F

G

H

I

J

K

L

M

N

O

P

# P1554 BATTERY CURRENT SENSOR

< DTC/CIRCUIT DIAGNOSIS >

[VK56VD FOR USA AND CANADA]

## P1554 BATTERY CURRENT SENSOR

### DTC Logic

INFOID:000000007187712

### DTC DETECTION LOGIC

| DTC No. | Trouble diagnosis name<br>(Trouble diagnosis content)      | DTC detecting condition  | Possible cause  |
|---------|--|--|---|
| P1554   | BAT CURRENT SENSOR<br>(Battery current sensor performance) | The output voltage of the battery current sensor is lower than the specified value while the battery voltage is high enough. | <ul style="list-style-type: none"><li>• Harness or connectors<br/>(Battery current sensor circuit is shorted.)<br/>(Crankshaft position sensor circuit is open or shorted.)<br/>[Camshaft position sensor (bank 1) circuit is shorted.]<br/>(Accelerator pedal position sensor 2 circuit is shorted.)<br/>(EVAP control system pressure sensor circuit is shorted.)<br/>(Refrigerant pressure sensor circuit is shorted.)</li><li>• Battery current sensor</li><li>• Crankshaft position sensor</li><li>• Camshaft position sensor (bank 1)</li><li>• Accelerator pedal position sensor 2</li><li>• EVAP control system pressure sensor</li><li>• Refrigerant pressure sensor</li></ul> |

### DTC CONFIRMATION PROCEDURE

#### 1. PERFORM COMPONENT FUNCTION CHECK

Perform Component Function Check. Refer to [EC-1448, "Component Function Check"](#).

#### NOTE:

Use Component Function Check to check the overall function of the battery current sensor circuit. During this check, a 1st trip DTC might not be confirmed.

Is the inspection result normal?

YES >> INSPECTION END

NO >> Proceed to [EC-1449, "Diagnosis Procedure"](#).

### Component Function Check

INFOID:000000007187713

#### 1. PRECONDITIONING

#### TESTING CONDITION:

- Before performing the following procedure, confirm that battery voltage is 12.8 V or more at idle.
- Before performing the following procedure, confirm that all load switches and A/C switch are turned OFF.

>> GO TO 2.

#### 2. PERFORM COMPONENT FUNCTION CHECK

##### ④ WITH CONSULT

1. Start engine and let it idle.
2. Select "BAT CUR SEN" in "DATA MONITOR" mode with CONSULT.
3. Check "BAT CUR SEN" indication for 10 seconds.  
"BAT CUR SEN" should be above 2,300 mV at least once.

##### ⊗ WITHOUT CONSULT

1. Start engine and let it idle.
2. Check the voltage between ECM harness connector terminals as per the following.



# P1554 BATTERY CURRENT SENSOR

< DTC/CIRCUIT DIAGNOSIS >

[VK56VD FOR USA AND CANADA]

| ECM       |  |          | Voltage (V)             |
|-----------|--|----------|-------------------------|
| Connector | +                                      | -        |                         |
|           | Terminal                               | Terminal |                         |
| M160      | 138<br>(Battery current sensor signal) | 150      | Above 2.3 at least once |

Is the inspection result normal?

YES >> INSPECTION END

NO >> Proceed to [EC-1449, "Diagnosis Procedure"](#).

## Diagnosis Procedure

INFOID:000000007187714

### 1.CHECK BATTERY CURRENT SENSOR POWER SUPPLY CIRCUIT-I

1. Disconnect battery current sensor harness connector.
2. Turn ignition switch ON.
3. Check the voltage between battery current sensor harness connector and ground.

| Battery current sensor |          | Ground | Voltage (V) |
|------------------------|----------|--------|-------------|
| Connector              | Terminal |        |             |
| E21                    | 1        | Ground | Approx. 5   |

Is the inspection result normal?

YES >> GO TO 7.

NO >> GO TO 2.

### 2.CHECK BATTERY CURRENT SENSOR POWER SUPPLY CIRCUIT-II

1. Turn ignition switch ON.
2. Disconnect ECM harness connector.
3. Check the continuity between battery current sensor harness connector and ECM harness connector.

| Battery current sensor |          | ECM       |          | Continuity |
|------------------------|----------|-----------|----------|------------|
| Connector              | Terminal | Connector | Terminal |            |
| E21                    | 1        | M160      | 133      | Existed    |

Is the inspection result normal?

YES >> GO TO 3.

NO >> Repair open circuit.

### 3.CHECK SENSOR POWER SUPPLY CIRCUIT

Check harness for short to power and short to ground, between the following terminals.

| ECM       |          | Sensor                              |           |          |
|-----------|----------|-------------------------------------|-----------|----------|
| Connector | Terminal | Name                                | Connector | Terminal |
| F111      | 76       | CKP sensor                          | F2        | 1        |
|           | 77       | Camshaft position sensor (bank 1)   | F84       | 1        |
| M160      | 133      | Battery current sensor              | E21       | 1        |
|           | 133      | EVAP control system pressure sensor | B73       | 3        |
|           | 133      | Refrigerant pressure sensor         | E77       | 3        |
|           | 131      | APP sensor 2 (Without ICC)          | M9        | 6        |
|           | 131      | APP sensor 2 (With ICC)             | M153      | 3        |

Is the inspection result normal?

YES >> GO TO 4.

NO >> Repair short to ground or short to power in harness or connectors.

# P1554 BATTERY CURRENT SENSOR

[VK56VD FOR USA AND CANADA]

< DTC/CIRCUIT DIAGNOSIS >

## 4. CHECK COMPONENTS

Check the following.

- Camshaft position sensor (bank 1) (Refer to [EC-1312, "Component Inspection \(Camshaft Position Sensor\)"](#).)
- CKP sensor (Refer to [EC-1307, "Component Inspection \(Crankshaft Position Sensor\)"](#).)
- EVAP control system pressure sensor (Refer to [EC-1343, "Component Inspection \(EVAP Control System Pressure Sensor\)"](#).)
- Refrigerant pressure sensor (Refer to [EC-1539, "Diagnosis Procedure"](#).)

Is the inspection result normal?

YES >> GO TO 5.

NO >> Replace malfunctioning component.

## 5. CHECK APP SENSOR

Refer to [EC-1497, "Component Inspection \(Accelerator Pedal Position Sensor\)"](#).

Is the inspection result normal?

YES >> GO TO 10.

NO >> GO TO 6.

## 6. REPLACE ACCELERATOR PEDAL ASSEMBLY

Replace accelerator pedal assembly.

- Models without Distance Control Assist system: [ACC-3, "MODELS WITHOUT DISTANCE CONTROL ASSIST SYSTEM : Removal and Installation"](#)
- Models with Distance Control Assist system: [ACC-3, "MODELS WITHOUT DISTANCE CONTROL ASSIST SYSTEM : Removal and Installation"](#)

>> INSPECTION END

## 7. CHECK BATTERY CURRENT SENSOR GROUND CIRCUIT FOR OPEN AND SHORT

1. Turn ignition switch OFF.
2. Disconnect ECM harness connector.
3. Check the continuity between battery current sensor harness connector and ECM harness connector.

| Battery current sensor |          | ECM       |          | Continuity |
|------------------------|----------|-----------|----------|------------|
| Connector              | Terminal | Connector | Terminal |            |
| E21                    | 3        | M160      | 150      | Existed    |

4. Also check harness for short to ground and short to power.

Is the inspection result normal?

YES >> GO TO 8.

NO >> Repair open circuit, short to ground or short to power in harness or connectors.

## 8. CHECK BATTERY CURRENT SENSOR INPUT SIGNAL CIRCUIT FOR OPEN AND SHORT

1. Check the continuity between battery current sensor harness connector and ECM harness connector.

| Battery current sensor |          | ECM       |          | Continuity |
|------------------------|----------|-----------|----------|------------|
| Connector              | Terminal | Connector | Terminal |            |
| E21                    | 4        | M160      | 138      | Existed    |

2. Also check harness for short to ground and short to power.

Is the inspection result normal?

YES >> GO TO 9.

NO >> Repair open circuit, short to ground or short to power in harness or connectors.

## 9. CHECK BATTERY CURRENT SENSOR

Refer to [EC-1451, "Component Inspection \(Battery Current Sensor\)"](#).

Is the inspection result normal?

# P1554 BATTERY CURRENT SENSOR

[VK56VD FOR USA AND CANADA]

< DTC/CIRCUIT DIAGNOSIS >

- YES >> GO TO 10.
- NO >> Replace battery negative cable assembly.

## 10.CHECK INTERMITTENT INCIDENT

Refer to [GI-44. "Intermittent Incident"](#).

>> INSPECTION END

## Component Inspection (Battery Current Sensor)

INFOID:000000007187715

### 1.CHECK BATTERY CURRENT SENSOR

1. Turn ignition switch OFF.
2. Reconnect harness connectors disconnected.
3. Disconnect battery negative cable.
4. Install jumper cable between battery negative terminal and body ground.
5. Turn ignition switch ON.
6. Check the voltage between ECM harness connector terminals under the following conditions.

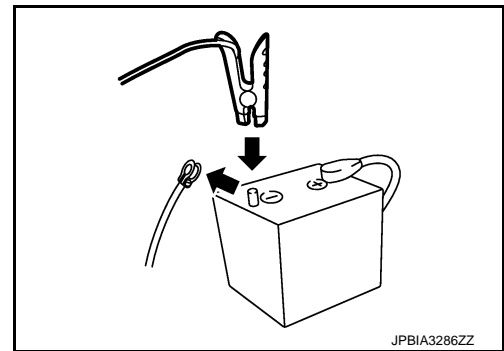

| Connector | ECM                                    |          | Voltage (V) |
|-----------|--|----------|-------------|
|           | +                                      | -        |             |
|           | Terminal                               | Terminal |             |
| M160      | 138<br>(Battery current sensor signal) | 150      | Approx. 2.5 |

Before measuring the terminal voltage, confirm that the battery is fully charged. Refer to [PG-135. "How to Handle Battery"](#).

Is the inspection result normal?

- YES >> INSPECTION END
- NO >> Replace battery negative cable assembly.

# P1556, P1557 BATTERY TEMPERATURE SENSOR

< DTC/CIRCUIT DIAGNOSIS >

[VK56VD FOR USA AND CANADA]

## P1556, P1557 BATTERY TEMPERATURE SENSOR

### DTC Logic

INFOID:000000007187716

### DTC DETECTION LOGIC

| DTC No. | Trouble diagnosis name<br>(Trouble diagnosis content)               | DTC detecting condition   | Possible cause  |
|---------|---|---|---|
| P1556   | BAT TMP SEN/CIRC<br>(Battery temperature sensor circuit low input)  | Signal voltage from Battery temperature sensor remains 0.16V or less for 5 seconds or more. | <ul style="list-style-type: none"> <li>• Harness or connectors<br/>[Battery current sensor (Battery temperature sensor) circuit is shorted.]<br/>(Crankshaft position sensor circuit is open or shorted.)<br/>[Camshaft position sensor (bank 1) circuit is shorted.]<br/>(Accelerator pedal position sensor 2 circuit is shorted.)<br/>(EVAP control system pressure sensor circuit is shorted.)<br/>(Refrigerant pressure sensor circuit is shorted.)</li> <li>• Battery current sensor (Battery temperature sensor)</li> <li>• Crankshaft position sensor</li> <li>• Camshaft position sensor (bank 1)</li> <li>• Accelerator pedal position sensor 2</li> <li>• EVAP control system pressure sensor</li> <li>• Refrigerant pressure sensor</li> </ul> |
| P1557   | BAT TMP SEN/CIRC<br>(Battery temperature sensor circuit high input) | Signal voltage from Battery temperature sensor remains 4.84V or more for 5 seconds or more. |   |

### DTC CONFIRMATION PROCEDURE

#### 1. PRECONDITIONING

1. Turn ignition switch OFF and wait at least 10 seconds.
2. Turn ignition switch ON.
3. Turn ignition switch OFF and wait at least 10 seconds.

#### TESTING CONDITION:

Before performing the following procedure, confirm that battery voltage is 10 V or more at idle.

>> GO TO 2.

#### 2. PERFORM DTC CONFIRMATION PROCEDURE

1. Start the engine and let it idle at least 10 seconds.
2. Check 1st trip DTC.

Is 1st trip DTC detected?

YES >> Proceed to [EC-1452, "Diagnosis Procedure"](#).

NO >> INSPECTION END

### Diagnosis Procedure

INFOID:000000007187717

#### 1. CHECK BATTERY TEMPERATURE SENSOR INPUT SIGNAL CIRCUIT-I

1. Disconnect battery current sensor harness connector.
2. Turn ignition switch ON.
3. Check the voltage between battery current sensor harness connector and ground.

| Battery current sensor |          | Ground | Voltage (V) |
|------------------------|----------|--------|-------------|
| Connector              | Terminal |        |             |
| E21                    | 2        | Ground | Approx. 5   |

Is the inspection result normal?

YES >> GO TO 7.

# P1556, P1557 BATTERY TEMPERATURE SENSOR

< DTC/CIRCUIT DIAGNOSIS >

[VK56VD FOR USA AND CANADA]

NO >> GO TO 2.

## 2.CHECK BATTERY TEMPERATURE SENSOR INPUT SIGNAL CIRCUIT-II

1. Turn ignition switch ON.
2. Disconnect ECM harness connector.
3. Check the continuity between battery current sensor harness connector and ECM harness connector.

| Battery current sensor |          | ECM       |          | Continuity |
|------------------------|----------|-----------|----------|------------|
| Connector              | Terminal | Connector | Terminal |            |
| E21                    | 2        | M160      | 139      | Existed    |

Is the inspection result normal?

YES >> GO TO 3.

NO >> Repair open circuit.

## 3.CHECK SENSOR POWER SUPPLY CIRCUIT

Check harness for short to power and short to ground, between the following terminals.

| ECM       |          | Sensor                              |           |          |
|-----------|----------|-------------------------------------|-----------|----------|
| Connector | Terminal | Name                                | Connector | Terminal |
| F111      | 76       | CKP sensor                          | F2        | 1        |
|           | 77       | Camshaft position sensor (bank 1)   | F84       | 1        |
| M160      | 133      | Battery current sensor              | E21       | 1        |
|           | 133      | EVAP control system pressure sensor | B73       | 3        |
|           | 133      | Refrigerant pressure sensor         | E77       | 3        |
|           | 131      | APP sensor 2 (Without ICC)          | M9        | 6        |
|           | 131      | APP sensor 2 (With ICC)             | M153      | 3        |

Is the inspection result normal?

YES >> GO TO 4.

NO >> Repair short to ground or short to power in harness or connectors.

## 4.CHECK COMPONENTS

Check the following.

- Camshaft position sensor (bank 1) (Refer to [EC-1312, "Component Inspection \(Camshaft Position Sensor\)"](#).)
- CKP sensor (Refer to [EC-1307, "Component Inspection \(Crankshaft Position Sensor\)"](#).)
- Battery current sensor (Refer to [EC-1451, "Component Inspection \(Battery Current Sensor\)"](#).)
- EVAP control system pressure sensor (Refer to [EC-1343, "Component Inspection \(EVAP Control System Pressure Sensor\)"](#).)
- Refrigerant pressure sensor (Refer to [EC-1539, "Diagnosis Procedure"](#).)

Is the inspection result normal?

YES >> GO TO 5.

NO >> Replace malfunctioning component.

## 5.CHECK APP SENSOR

Refer to [EC-1497, "Component Inspection \(Accelerator Pedal Position Sensor\)"](#).

Is the inspection result normal?

YES >> GO TO 9.

NO >> GO TO 6.

## 6.REPLACE ACCELERATOR PEDAL ASSEMBLY

Replace accelerator pedal assembly. Refer to following.

- Models without Distance Control Assist system: [ACC-3, "MODELS WITHOUT DISTANCE CONTROL ASSIST SYSTEM : Removal and Installation"](#)

# P1556, P1557 BATTERY TEMPERATURE SENSOR

< DTC/CIRCUIT DIAGNOSIS >

[VK56VD FOR USA AND CANADA]

- Models with Distance Control Assist system: [ACC-4. "MODELS WITH DISTANCE CONTROL ASSIST SYSTEM : Removal and Installation"](#)

>> INSPECTION END

## 7. CHECK BATTERY TEMPERATURE SENSOR GROUND CIRCUIT FOR OPEN AND SHORT

- Turn ignition switch OFF.
- Disconnect ECM harness connector.
- Check the continuity between battery current sensor harness connector and ECM harness connector.

| Battery current sensor |          | ECM       |          | Continuity |
|------------------------|----------|-----------|----------|------------|
| Connector              | Terminal | Connector | Terminal |            |
| E21                    | 3        | M160      | 150      | Existed    |

- Also check harness for short to ground and short to power.

Is the inspection result normal?

YES >> GO TO 8.

NO >> Repair open circuit, short to ground or short to power in harness or connectors.

## 8. CHECK BATTERY TEMPERATURE SENSOR

Refer to [EC-1454. "Component Inspection \(Battery Temperature Sensor\)"](#).

Is the inspection result normal?

YES >> GO TO 9.

NO >> Replace battery negative cable assembly.

## 9. CHECK INTERMITTENT INCIDENT

Refer to [GI-44. "Intermittent Incident"](#).

>> INSPECTION END

## Component Inspection (Battery Temperature Sensor)

INFOID:000000007187718

## 1. CHECK BATTERY TEMPERATURE SENSOR

- Turn ignition switch OFF.
- Disconnect battery current sensor.
- Check the resistance between battery current sensor connector terminals.

| Battery current sensor |   | Resistance   |
|------------------------|---|--|
| +                      | - |  |
| Terminal               |   |  |
| 2                      | 3 | continuity with the resistance value 100 Ω or more |

Is the inspection result normal?

YES >> INSPECTION END

NO >> Replace battery negative cable assembly.

# P1564 ASCD STEERING SWITCH

< DTC/CIRCUIT DIAGNOSIS >

[VK56VD FOR USA AND CANADA]

## P1564 ASCD STEERING SWITCH

### DTC Logic

INFOID:000000007187719

### DTC DETECTION LOGIC

#### NOTE:

If DTC P1564 is displayed with DTC P0605, first perform the trouble diagnosis for DTC P0605. Refer to [EC-1384, "DTC Logic"](#).

| DTC No. | Trouble diagnosis name<br>(Trouble diagnosis content) | DTC detecting condition  | Possible cause  |
|---------|---|--|---|
| P1564   | ASCD SW<br>(ASCD steering switch)                     | <ul style="list-style-type: none"> <li>An excessively high voltage signal from the ASCD steering switch is sent to ECM.</li> <li>ECM detects that input signal from the ASCD steering switch is out of the specified range.</li> <li>ECM detects that the ASCD steering switch is stuck ON.</li> </ul> | <ul style="list-style-type: none"> <li>Harness or connectors<br/>(The switch circuit is open or shorted.)</li> <li>ASCD steering switch</li> <li>ECM</li> </ul> |

### DTC CONFIRMATION PROCEDURE

#### 1. PRECONDITIONING

If DTC Confirmation Procedure has been previously conducted, always perform the following procedure before conducting the next test.

- Turn ignition switch OFF and wait at least 10 seconds.
- Turn ignition switch ON.
- Turn ignition switch OFF and wait at least 10 seconds.

>> GO TO 2.

#### 2. PERFORM DTC CONFIRMATION PROCEDURE

- Turn ignition switch ON and wait at least 10 seconds.
- Press MAIN switch for at least 10 seconds, then release it and wait at least 10 seconds.
- Press CANCEL switch for at least 10 seconds, then release it and wait at least 10 seconds.
- Press RESUME/ACCELERATE switch for at least 10 seconds, then release it and wait at least 10 seconds.
- Press SET/COAST switch for at least 10 seconds, then release it and wait at least 10 seconds.
- Check DTC.

#### Is DTC detected?

- YES >> Proceed to [EC-1455, "Diagnosis Procedure"](#).  
 NO >> INSPECTION END

### Diagnosis Procedure

INFOID:000000007187720

#### 1. CHECK ASCD STEERING SWITCH CIRCUIT

##### Ⓜ WITH CONSULT

- Turn ignition switch ON.
- Select "MAIN SW", "CANCEL SW", "RESUME/ACC SW" and "SET SW" in "DATA MONITOR" mode with CONSULT.
- Check each item indication under the following conditions.

| Monitor item | Condition     | Indication |     |
|--------------|---------------|------------|-----|
| MAIN SW      | MAIN switch   | Pressed    | ON  |
|              |               | Released   | OFF |
| CANCEL SW    | CANCEL switch | Pressed    | ON  |
|              |               | Released   | OFF |

# P1564 ASCD STEERING SWITCH

< DTC/CIRCUIT DIAGNOSIS >

[VK56VD FOR USA AND CANADA]

| Monitor item  | Condition                |          | Indication |
|---------------|--------------------------|----------|------------|
| RESUME/ACC SW | RESUME/ACCELERATE switch | Pressed  | ON         |
|               |                          | Released | OFF        |
| SET SW        | SET/COAST switch         | Pressed  | ON         |
|               |                          | Released | OFF        |

**⊗ WITHOUT CONSULT**

1. Turn ignition switch ON.
2. Check the voltage between ECM harness connector terminals under the following conditions.

| ECM       |                                      |          | Condition                            | Voltage (V) |
|-----------|--------------------------------------|----------|--------------------------------------|-------------|
| Connector | +                                    | -        |                                      |             |
|           | Terminal                             | Terminal |                                      |             |
| M160      | 128<br>(ASCD steering switch signal) | 130      | MAIN switch: Pressed                 | Approx. 0   |
|           |                                      |          | CANCEL switch: Pressed               | Approx. 1   |
|           |                                      |          | COAST/SET switch: Pressed            | Approx. 2   |
|           |                                      |          | ACCELERATE/RESUME switch: Pressed    | Approx. 3   |
|           |                                      |          | All ASCD steering switches: Released | Approx. 4   |

Is the inspection result normal?

- YES >> GO TO 7.  
NO >> GO TO 2.

## 2.CHECK ASCD STEERING SWITCH GROUND CIRCUIT FOR OPEN AND SHORT

1. Turn ignition switch OFF.
2. Disconnect ECM harness connector.
3. Disconnect combination switch harness connector.
4. Check the continuity between combination switch and ECM harness connector.

| Combination switch |          | ECM       |          | Continuity |
|--------------------|----------|-----------|----------|------------|
| Connector          | Terminal | Connector | Terminal |            |
| M303               | 16       | M160      | 130      | Existed    |

5. Also check harness for short to ground and short to power.

Is the inspection result normal?

- YES >> GO TO 4.  
NO >> GO TO 3.

## 3.DETECT MALFUNCTIONING PART

Check the following.

- Combination switch (spiral cable)
- Harness for open and short between ECM and combination switch

>> Repair open circuit, short to ground or short to power in harness or connectors.

## 4.CHECK ASCD STEERING SWITCH INPUT SIGNAL CIRCUIT FOR OPEN AND SHORT

1. Check the continuity between combination switch and ECM harness connector.

| Combination switch |          | ECM       |          | Continuity |
|--------------------|----------|-----------|----------|------------|
| Connector          | Terminal | Connector | Terminal |            |
| M303               | 13       | M160      | 128      | Existed    |

2. Also check harness for short to ground and short to power.

Is the inspection result normal?

- YES >> GO TO 6.



# P1564 ASCD STEERING SWITCH

[VK56VD FOR USA AND CANADA]

< DTC/CIRCUIT DIAGNOSIS >

NO >> GO TO 5.

## 5. DETECT MALFUNCTIONING PART

Check the following.

- Combination switch (spiral cable)
- Harness for open and short between ECM and combination switch

>> Repair open circuit, short to ground or short to power in harness or connectors.

## 6. CHECK ASCD STEERING SWITCH

Refer to [EC-1457, "Component Inspection \(ASCD Steering Switch\)"](#).

Is the inspection result normal?

YES >> GO TO 7.

NO >> Replace ASCD steering switch. Refer to [EC-990, "ENGINE CONTROL SYSTEM : Component Parts Location"](#).

## 7. CHECK INTERMITTENT INCIDENT

Refer to [GI-44, "Intermittent Incident"](#).

>> INSPECTION END

## Component Inspection (ASCD Steering Switch)

INFOID:000000007187721

## 1. CHECK ASCD STEERING SWITCH

1. Turn ignition switch OFF.
2. Disconnect combination switch (spiral cable) harness connector M303.
3. Check resistance between combination switch harness connector terminals under the following conditions.

| Combination switch |           | Condition                            | Resistance (Ω) |
|--------------------|-----------|--------------------------------------|----------------|
| Connector          | Terminals |                                      |                |
| M303               | 13 and 16 | MAIN switch: Pressed                 | Approx. 0      |
|                    |           | CANCEL switch: Pressed               | Approx. 250    |
|                    |           | SET/COAST switch: Pressed            | Approx. 660    |
|                    |           | RESUME/ACCELERATE switch: Pressed    | Approx. 1,480  |
|                    |           | All ASCD steering switches: Released | Approx. 4,000  |

Is the inspection result normal?

YES >> INSPECTION END

NO >> Replace ASCD steering switch. Refer to [EC-990, "ENGINE CONTROL SYSTEM : Component Parts Location"](#).

# P1564 ICC STEERING SWITCH

< DTC/CIRCUIT DIAGNOSIS >

[VK56VD FOR USA AND CANADA]

## P1564 ICC STEERING SWITCH

### DTC Logic

INFOID:000000007187722

### DTC DETECTION LOGIC

#### NOTE:

If DTC P1564 is displayed with DTC P0605, first perform the trouble diagnosis for DTC P0605. Refer to [EC-1384, "DTC Logic"](#).

| DTC No. | Trouble diagnosis name<br>(Trouble diagnosis content) | DTC detecting condition   | Possible cause   |
|---------|---|---|--|
| P1564   | ASCD SW<br>(ICC steering switch)                      | <ul style="list-style-type: none"><li>• An excessively high voltage signal from the ICC steering switch is sent to ECM.</li><li>• ECM detects that input signal from the ICC steering switch is out of the specified range.</li><li>• ECM detects that the ICC steering switch is stuck ON.</li></ul> | <ul style="list-style-type: none"><li>• Harness or connectors<br/>(The switch circuit is open or shorted.)</li><li>• ICC steering switch</li><li>• ECM</li></ul> |

### DTC CONFIRMATION PROCEDURE

#### 1. PRECONDITIONING

If DTC Confirmation Procedure has been previously conducted, always perform the following procedure before conducting the next test.

1. Turn ignition switch OFF and wait at least 10 seconds.
2. Turn ignition switch ON.
3. Turn ignition switch OFF and wait at least 10 seconds.

>> GO TO 2.

#### 2. PERFORM DTC CONFIRMATION PROCEDURE

1. Turn ignition switch ON and wait at least 10 seconds.
2. Press MAIN switch for at least 10 seconds, then release it and wait at least 10 seconds.
3. Press CANCEL switch for at least 10 seconds, then release it and wait at least 10 seconds.
4. Press RESUME/ACCELERATE switch for at least 10 seconds, then release it and wait at least 10 seconds.
5. Press SET/COAST switch for at least 10 seconds, then release it and wait at least 10 seconds.
6. Press DISTANCE switch for at least 10 seconds, then release it and wait at least 10 seconds.
7. Press LDP switch for at least 10 seconds, then release it and wait at least 10 seconds.
8. Check DTC.

#### Is DTC detected?

- YES >> Proceed to [EC-1458, "Diagnosis Procedure"](#).  
NO >> INSPECTION END

### Diagnosis Procedure

INFOID:000000007187723

#### 1. CHECK ICC STEERING SWITCH CIRCUIT

1. Turn ignition switch ON.
2. Check the voltage between ECM harness connector terminals under the following conditions.

# P1564 ICC STEERING SWITCH

< DTC/CIRCUIT DIAGNOSIS >

[VK56VD FOR USA AND CANADA]

| ECM       |                                     |          | Condition                                | Voltage (V) |
|-----------|-------------------------------------|----------|--|-------------|
| Connector | +                                   | -        |  |             |
|           | Terminal                            | Terminal |  |             |
| M160      | 102<br>(ICC steering switch signal) | 111      | MAIN switch: Pressed                     | Approx. 0   |
|           |                                     |          | DYNAMIC DRIVE ASSISTANCE switch: Pressed | Approx. 1.0 |
|           |                                     |          | CANCEL switch: Pressed                   | Approx. 1.9 |
|           |                                     |          | DISTANCE switch: Pressed                 | Approx. 2.6 |
|           |                                     |          | COAST/SET switch: Pressed                | Approx. 3.2 |
|           |                                     |          | ACCELERATE/RESUME switch: Pressed        | Approx. 3.7 |
|           |                                     |          | All ICC steering switches: Released      | Approx. 4.2 |

Is the inspection result normal?

YES >> GO TO 7.

NO >> GO TO 2.

## 2.CHECK ICC STEERING SWITCH GROUND CIRCUIT FOR OPEN AND SHORT

1. Turn ignition switch OFF.
2. Disconnect ECM harness connector.
3. Disconnect combination switch harness connector.
4. Check the continuity between combination switch and ECM harness connector.

| Combination switch |          | ECM       |          | Continuity |
|--------------------|----------|-----------|----------|------------|
| Connector          | Terminal | Connector | Terminal |            |
| M303               | 16       | M160      | 130      | Existed    |

5. Also check harness for short to ground and short to power.

Is the inspection result normal?

YES >> GO TO 4.

NO >> GO TO 3.

## 3.DETECT MALFUNCTIONING PART

Check the following.

- Combination switch (spiral cable)
- Harness for open and short between ECM and combination switch

>> Repair open circuit, short to ground or short to power in harness or connectors.

## 4.CHECK ICC STEERING SWITCH INPUT SIGNAL CIRCUIT FOR OPEN AND SHORT

1. Check the continuity between combination switch and ECM harness connector.

| Combination switch |          | ECM       |          | Continuity |
|--------------------|----------|-----------|----------|------------|
| Connector          | Terminal | Connector | Terminal |            |
| M303               | 13       | M160      | 128      | Existed    |

2. Also check harness for short to ground and short to power.

Is the inspection result normal?

YES >> GO TO 6.

NO >> GO TO 5.

## 5.DETECT MALFUNCTIONING PART

Check the following.

- Combination switch (spiral cable)
- Harness for open and short between ECM and combination switch

# P1564 ICC STEERING SWITCH

< DTC/CIRCUIT DIAGNOSIS >

[VK56VD FOR USA AND CANADA]

>> Repair open circuit, short to ground or short to power in harness or connectors.

## 6. CHECK ICC STEERING SWITCH

Refer to [EC-1460, "Component Inspection \(ICC Steering Switch\)"](#).

Is the inspection result normal?

YES >> GO TO 7.

NO >> Replace ICC steering switch. Refer to [EC-990, "ENGINE CONTROL SYSTEM : Component Parts Location"](#).

## 7. CHECK INTERMITTENT INCIDENT

Refer to [GI-44, "Intermittent Incident"](#).

>> INSPECTION END

## Component Inspection (ICC Steering Switch)

INFOID:000000007187724

### 1. CHECK ICC STEERING SWITCH

1. Turn ignition switch OFF.
2. Disconnect combination switch (spiral cable) harness connector M303.
3. Check resistance between combination switch harness connector terminals under the following conditions.

| Combination switch |           | Condition                                | Resistance (Ω) |
|--------------------|-----------|--|----------------|
| Connector          | Terminals |  |                |
| M303               | 13 and 16 | MAIN switch: Pressed                     | Approx. 0      |
|                    |           | DYNAMIC DRIVE ASSISTANCE switch: Pressed | Approx. 270    |
|                    |           | CANCEL switch: Pressed                   | Approx. 620    |
|                    |           | DISTANCE switch: Pressed                 | Approx. 1,100  |
|                    |           | SET/COAST switch: Pressed                | Approx. 1,810  |
|                    |           | RESUME/ACCELERATE switch: Pressed        | Approx. 3,000  |
|                    |           | All ICC steering switches: Released      | Approx. 5,420  |

Is the inspection result normal?

YES >> INSPECTION END

NO >> Replace ICC steering switch. Refer to [EC-990, "ENGINE CONTROL SYSTEM : Component Parts Location"](#).

## P1568 ICC FUNCTION

### DTC Logic

INFOID:000000007187725

#### DTC DETECTION LOGIC

##### NOTE:

- If DTC P1568 is displayed with DTC UXXXX, perform the trouble diagnosis for DTC UXXXX.
- If DTC P1568 is displayed with DTC P0605, perform the trouble diagnosis for DTC P0605. Refer to [EC-1384, "DTC Logic"](#).
- If DTC P1568 is displayed with DTC P0607, perform the trouble diagnosis for DTC P0607. Refer to [EC-1386, "DTC Logic"](#).

| DTC No. | Trouble diagnosis name<br>(Trouble diagnosis content) | DTC Detecting Condition  | Possible Cause   |
|---------|---|--|--|
| P1568   | ICC COMMAND VALUE<br>(ICC function)                   | ECM detects a difference between signals from ADAS control unit is out of specified range. | <ul style="list-style-type: none"> <li>• Harness or connectors<br/>(The CAN communication line is open or shorted.)</li> <li>• ADAS control unit</li> <li>• ECM</li> </ul> |

#### DTC CONFIRMATION PROCEDURE

##### 1. PRECONDITIONING

If DTC Confirmation Procedure has been previously conducted, always perform the following procedure before conducting the next test.

1. Turn ignition switch OFF and wait at least 10 seconds.
2. Turn ignition switch ON.
3. Turn ignition switch OFF and wait at least 10 seconds.

##### TESTING CONDITION:

**Step 2 may be conducted with the drive wheels lifted in the shop or by driving the vehicle. If a road test is expected to be easier, it is unnecessary to lift the vehicle.**

>> GO TO 2.

##### 2. PERFORM DTC CONFIRMATION PROCEDURE

1. Turn ignition switch ON.
2. Press MAIN switch on ICC steering switch.
3. Drive the vehicle at more than 40 km/h (25 MPH).

##### CAUTION:

**Always drive vehicle at a safe speed.**

4. Press SET/COAST switch.
5. Check DTC.

##### Is DTC detected?

- YES >> Proceed to [EC-1461, "Diagnosis Procedure"](#).  
 NO >> INSPECTION END

#### Diagnosis Procedure

INFOID:000000007187726

##### 1. REPLACE ADAS CONTROL UNIT

1. Replace ADAS control unit. Refer to [DAS-55, "Removal and Installation"](#).
2. Check DTC of ADAS control unit. Refer to [DAS-22, "CONSULT Function \(ICC/ADAS\)"](#).

>> INSPECTION END

# P1572 ASCD BRAKE SWITCH

< DTC/CIRCUIT DIAGNOSIS >

[VK56VD FOR USA AND CANADA]

## P1572 ASCD BRAKE SWITCH

### DTC Logic

INFOID:000000007187727

#### DTC DETECTION LOGIC

##### NOTE:

- If DTC P1572 is displayed with DTC P0605, first perform the trouble diagnosis for DTC P0605. Refer to [EC-1384, "DTC Logic"](#).
- This self-diagnosis has the one trip detection logic. When malfunction A is detected, DTC is not stored in ECM memory. And in that case, 1st trip DTC and 1st trip freeze frame data are displayed. 1st trip DTC is erased when ignition switch is turned OFF. And even when malfunction A is detected in two consecutive trips, DTC is not stored in ECM memory.

| DTC No. | Trouble diagnosis name<br>(Trouble diagnosis content) | DTC detecting condition |   | Possible cause  |
|---------|---|-------------------------|---|---|
| P1572   | ASCDC BRAKE SW<br>(ASCDC brake switch)                | A)                      | When the vehicle speed is above 30 km/h (19 MPH), ON signals from the stop lamp switch and the ASCDC brake switch are sent to the ECM at the same time. | <ul style="list-style-type: none"><li>• Harness or connectors<br/>(The stop lamp switch circuit is shorted.)</li><li>• Harness or connectors<br/>(The ASCDC brake switch circuit is shorted.)</li><li>• Stop lamp switch</li><li>• ASCDC brake switch</li><li>• Incorrect stop lamp switch installation</li><li>• Incorrect ASCDC brake switch installation</li><li>• ECM</li></ul> |
|         |   | B)                      | ASCDC brake switch signal is not sent to ECM for extremely long time while the vehicle is being driven.   |   |

#### DTC CONFIRMATION PROCEDURE

##### 1. PRECONDITIONING

If DTC Confirmation Procedure has been previously conducted, always perform the following procedure before conducting the next test.

1. Turn ignition switch OFF and wait at least 10 seconds.
2. Turn ignition switch ON.
3. Turn ignition switch OFF and wait at least 10 seconds.

##### NOTE:

The procedure for malfunction B is not described. It takes an extremely long time to complete the procedure for malfunction B. By performing the procedure for malfunction A, the condition that causes malfunction B can be detected.

>> GO TO 2.

##### 2. PERFORM DTC CONFIRMATION PROCEDURE FOR MALFUNCTION A

1. Start engine (VDC switch OFF).
2. Press MAIN switch and check that CRUISE indicator is displayed in combination meter.
3. Drive the vehicle for at least 5 consecutive seconds under the following conditions.

##### CAUTION:

**Always drive vehicle at a safe speed.**

##### NOTE:

**This procedure may be conducted with the drive wheels lifted in the shop or by driving the vehicle. If a road test is expected to be easier, it is unnecessary to lift the vehicle.**

|                |                            |
|----------------|----------------------------|
| Vehicle speed  | More than 30 km/h (19 mph) |
| Selector lever | Suitable position          |

4. Check 1st trip DTC.

Is 1st trip DTC detected?

YES >> Proceed to [EC-1463, "Diagnosis Procedure"](#).

NO >> GO TO 3.

##### 3. PERFORM DTC CONFIRMATION PROCEDURE

# P1572 ASCD BRAKE SWITCH

< DTC/CIRCUIT DIAGNOSIS >

[VK56VD FOR USA AND CANADA]

1. Drive the vehicle for at least 5 consecutive seconds under the following conditions.

**CAUTION:**

**Always drive vehicle at a safe speed.**

**NOTE:**

**This procedure may be conducted with the drive wheels lifted in the shop or by driving the vehicle. If a road test is expected to be easier, it is unnecessary to lift the vehicle.**

|                  |   |
|------------------|---|
| Vehicle speed    | More than 30 km/h (19 mph)  |
| Selector lever   | Suitable position   |
| Driving location | Depress the brake pedal for more than 5 seconds so as not to come off from the above-mentioned vehicle speed. |

2. Check 1st trip DTC.

Is 1st trip DTC detected?

- YES >> Proceed to [EC-1463. "Diagnosis Procedure"](#).  
NO >> INSPECTION END

## Diagnosis Procedure

INFOID:000000007187728

### 1.CHECK OVERALL FUNCTION-I

WITH CONSULT

1. Turn ignition switch ON.
2. Select "BRAKE SW1" in "DATA MONITOR" mode with CONSULT.
3. Check "BRAKE SW1" indication under the following conditions.

| Monitor item                     | Condition   |                    | Indication |
|----------------------------------|-------------|--------------------|------------|
| BRAKE SW1<br>(ASCD brake switch) | Brake pedal | Slightly depressed | OFF        |
|                                  |             | Fully released     | ON         |

WITHOUT CONSULT

1. Turn ignition switch ON.
2. Check the voltage between ECM harness connector terminals as per the following.

| ECM       |                                   |          | Condition          | Voltage (V)     |
|-----------|-----------------------------------|----------|--------------------|-----------------|
| Connector | +                                 | -        |                    |                 |
|           | Terminal                          | Terminal |                    |                 |
| M160      | 147<br>(ASCD brake switch signal) | 175      | Slightly depressed | Approx. 0       |
|           |                                   |          | Fully released     | Battery voltage |

Is the inspection result normal?

- YES >> GO TO 2.  
NO >> GO TO 3.

### 2.CHECK OVERALL FUNCTION-II

WITH CONSULT

Select "BRAKE SW2" and check indication under the following conditions.

| Monitor item                    | Condition   |                    | Indication |
|---------------------------------|-------------|--------------------|------------|
| BRAKE SW2<br>(Stop lamp switch) | Brake pedal | Slightly depressed | ON         |
|                                 |             | Fully released     | OFF        |

WITHOUT CONSULT

Check the voltage between ECM harness connector terminals under the following conditions.

# P1572 ASCD BRAKE SWITCH

< DTC/CIRCUIT DIAGNOSIS >

[VK56VD FOR USA AND CANADA]

| ECM       |                                  |          | Condition          | Voltage (V)     |
|-----------|----------------------------------|----------|--------------------|-----------------|
| Connector | +                                | -        |                    |                 |
|           | Terminal                         | Terminal |                    |                 |
| M160      | 158<br>(Stop lamp switch signal) | 175      | Slightly depressed | Battery voltage |
|           |                                  |          | Fully released     | Approx. 0       |

Is the inspection result normal?

- YES >> GO TO 13.  
NO >> GO TO 8.

## 3. CHECK ASCD BRAKE SWITCH POWER SUPPLY CIRCUIT

1. Turn ignition switch OFF.
2. Disconnect ASCD brake switch harness connector.
3. Turn ignition switch ON.
4. Check the voltage between ASCD brake switch harness connector and ground.

| ASCD brake switch |          | Ground | Voltage         |
|-------------------|----------|--------|-----------------|
| Connector         | Terminal |        |                 |
| E109              | 1        | Ground | Battery voltage |

Is the inspection result normal?

- YES >> GO TO 5.  
NO >> GO TO 4.

## 4. DETECT MALFUNCTIONING PART

Check the following.

- 10 A fuse (No. 3)
- Harness for open or short between ASCD brake switch and fuse
- Loose or poor connection for each connector and harness

>> Repair open circuit or short to ground in harness or connectors.

## 5. CHECK ASCD BRAKE SWITCH INPUT SIGNAL CIRCUIT FOR OPEN AND SHORT

1. Turn ignition switch OFF.
2. Disconnect ECM harness connector.
3. Check the continuity between ASCD brake switch harness connector and ECM harness connector.

| ASCD brake switch |          | ECM       |          | Continuity |
|-------------------|----------|-----------|----------|------------|
| Connector         | Terminal | Connector | Terminal |            |
| E109              | 2        | M160      | 147      | Existed    |

4. Also check harness for short to ground and short to power.

Is the inspection result normal?

- YES >> GO TO 7.  
NO >> GO TO 6.

## 6. DETECT MALFUNCTIONING PART

Check the following.

- Harness for open or short between ECM and ASCD brake switch
- Loose or poor connection for each connector and harness

>> Repair open circuit, short to ground or short to power in harness or connectors.

## 7. CHECK ASCD BRAKE SWITCH

Refer to [EC-1466, "Component Inspection \(ASCD Brake Switch\)"](#)

Is the inspection result normal?



# P1572 ASCD BRAKE SWITCH

[VK56VD FOR USA AND CANADA]

## < DTC/CIRCUIT DIAGNOSIS >

YES >> GO TO 13.

NO >> Replace ASCD brake switch. Refer to [BR-18, "Exploded View"](#).

### 8. CHECK STOP LAMP SWITCH POWER SUPPLY CIRCUIT

1. Turn ignition switch OFF.
2. Disconnect stop lamp switch harness connector.
3. Check the voltage between stop lamp switch harness connector and ground.

| Stop lamp switch |          | Ground | Voltage         |
|------------------|----------|--------|-----------------|
| Connector        | Terminal |        |                 |
| E110             | 1        | Ground | Battery voltage |

Is the inspection result normal?

YES >> GO TO 10.

NO >> GO TO 9.

### 9. DETECT MALFUNCTIONING PART

Check the following.

- 10 A fuse (No. 7)
- Harness for open or short between stop lamp switch and battery
- Loose or poor connection for each connector and harness

>> Repair open circuit, short to ground or short to power in harness or connectors.

### 10. CHECK STOP LAMP SWITCH INPUT SIGNAL CIRCUIT FOR OPEN AND SHORT

1. Disconnect ECM harness connector.
2. Check the continuity between stop lamp switch harness connector and ECM harness connector.

| Stop lamp switch |          | ECM       |          | Continuity |
|------------------|----------|-----------|----------|------------|
| Connector        | Terminal | Connector | Terminal |            |
| E110             | 2        | M160      | 158      | Existed    |

3. Also check harness for short to ground and short to power.

Is the inspection result normal?

YES >> GO TO 12.

NO >> GO TO 11.

### 11. DETECT MALFUNCTIONING PART

Check the following.

- Harness for open or short between ECM and stop lamp switch
- Loose or poor connection for each connector and harness

>> Repair open circuit, short to ground or short to power in harness or connectors.

### 12. CHECK STOP LAMP SWITCH

Refer to [EC-1466, "Component Inspection \(Stop Lamp Switch\)"](#).

Is the inspection result normal?

YES >> GO TO 13.

NO >> Replace stop lamp switch. Refer to [BR-18, "Exploded View"](#).

### 13. CHECK INTERMITTENT INCIDENT

Refer to [GI-44, "Intermittent Incident"](#).

>> INSPECTION END

# P1572 ASCD BRAKE SWITCH

< DTC/CIRCUIT DIAGNOSIS >

[VK56VD FOR USA AND CANADA]

## Component Inspection (ASCD Brake Switch)

INFOID:000000007187729

### 1.CHECK ASCD BRAKE SWITCH-I

1. Turn ignition switch OFF.
2. Disconnect ASCD brake switch harness connector.
3. Check the continuity between ASCD brake switch terminals under the following conditions.

| Terminals | Condition   |                    | Continuity  |
|-----------|-------------|--------------------|-------------|
| 1 and 2   | Brake pedal | Fully released     | Existed     |
|           |             | Slightly depressed | Not existed |

Is the inspection result normal?

YES >> INSPECTION END

NO >> GO TO 2.

### 2.CHECK ASCD BRAKE SWITCH-II

1. Adjust ASCD brake switch installation. Refer to [BR-19, "Inspection and Adjustment"](#).
2. Check the continuity between ASCD brake switch terminals under the following conditions.

| Terminals | Condition   |                    | Continuity  |
|-----------|-------------|--------------------|-------------|
| 1 and 2   | Brake pedal | Fully released     | Existed     |
|           |             | Slightly depressed | Not existed |

Is the inspection result normal?

YES >> INSPECTION END

NO >> Replace ASCD brake switch. Refer to [BR-18, "Exploded View"](#).

## Component Inspection (Stop Lamp Switch)

INFOID:000000007187730

### 1.CHECK STOP LAMP SWITCH-I

1. Turn ignition switch OFF.
2. Disconnect stop lamp switch harness connector.
3. Check the continuity between stop lamp switch terminals under the following conditions.

| Terminals | Condition   |                    | Continuity  |
|-----------|-------------|--------------------|-------------|
| 1 and 2   | Brake pedal | Fully released     | Not existed |
|           |             | Slightly depressed | Existed     |

Is the inspection result normal?

YES >> INSPECTION END

NO >> GO TO 2.

### 2.CHECK STOP LAMP SWITCH-II

1. Adjust stop lamp switch installation. Refer to [BR-19, "Inspection and Adjustment"](#).
2. Check the continuity between stop lamp switch terminals under the following conditions.

| Terminals | Condition   |                    | Continuity  |
|-----------|-------------|--------------------|-------------|
| 1 and 2   | Brake pedal | Fully released     | Not existed |
|           |             | Slightly depressed | Existed     |

Is the inspection result normal?

YES >> INSPECTION END

NO >> Replace stop lamp switch. Refer to [BR-18, "Exploded View"](#).

# P1572 ICC BRAKE SWITCH

< DTC/CIRCUIT DIAGNOSIS >

[VK56VD FOR USA AND CANADA]

## P1572 ICC BRAKE SWITCH

### DTC Logic

INFOID:000000007187731

### DTC DETECTION LOGIC

#### NOTE:

- If DTC P1572 is displayed with DTC P0605, first perform the trouble diagnosis for DTC P0605. Refer to [EC-1384, "DTC Logic"](#).
- This self-diagnosis has the one trip detection logic. When malfunction A is detected, DTC is not stored in ECM memory. And in that case, 1st trip DTC and 1st trip freeze frame data are displayed. 1st trip DTC is erased when ignition switch is turned OFF. And even when malfunction A is detected in two consecutive trips, DTC is not stored in ECM memory.

| DTC No. | Trouble diagnosis name<br>(Trouble diagnosis content) | DTC detecting condition |  | Possible cause   |
|---------|---|-------------------------|--|--|
| P1572   | ASCD BRAKE SW<br>(ICC brake switch)                   | A)                      | ON signals from the stop lamp switch and the ICC brake switch are sent to ECM at the same time.      | <ul style="list-style-type: none"><li>• Harness or connectors (The stop lamp switch circuit is shorted.)</li><li>• Harness or connectors (The ICC brake switch circuit is shorted.)</li><li>• Stop lamp switch</li><li>• ICC brake switch</li><li>• ICC brake hold relay</li><li>• Incorrect stop lamp switch installation</li><li>• Incorrect ICC brake switch installation</li><li>• ECM</li></ul> |
|         |   | B)                      | ICC brake switch signal is not sent to ECM for extremely long time while the vehicle is being driven |  |

### DTC CONFIRMATION PROCEDURE

#### 1. PRECONDITIONING

1. Turn ignition switch OFF and wait at least 10 seconds.
2. Turn ignition switch ON.
3. Turn ignition switch OFF and wait at least 10 seconds.

#### NOTE:

The procedure for malfunction B is not described. It takes an extremely long time to complete the procedure for malfunction B. By performing the procedure for malfunction A, the condition that causes malfunction B can be detected.

>> GO TO 2.

#### 2. PERFORM DTC CONFIRMATION PROCEDURE

1. Start engine (VDC switch OFF).
2. Press MAIN switch and check that CRUISE indicator is displayed in combination meter.
3. Drive the vehicle for at least 5 consecutive seconds under the following conditions.

#### CAUTION:

**Always drive vehicle at a safe speed.**

#### NOTE:

**This procedure may be conducted with the drive wheels lifted in the shop or by driving the vehicle. If a road test is expected to be easier, it is unnecessary to lift the vehicle.**

|                |                            |
|----------------|----------------------------|
| Vehicle speed  | More than 30 km/h (19 mph) |
| Selector lever | Suitable position          |

4. Check 1st trip DTC.

Is 1st trip DTC detected?

YES >> Proceed to [EC-1468, "Diagnosis Procedure"](#).

NO >> GO TO 3.

#### 3. PERFORM DTC CONFIRMATION PROCEDURE

1. Drive the vehicle for at least 5 consecutive seconds under the following conditions.

#### CAUTION:

# P1572 ICC BRAKE SWITCH

[VK56VD FOR USA AND CANADA]

< DTC/CIRCUIT DIAGNOSIS >

**Always drive vehicle at a safe speed.**

**NOTE:**

**This procedure may be conducted with the drive wheels lifted in the shop or by driving the vehicle. If a road test is expected to be easier, it is unnecessary to lift the vehicle.**

|                  |   |
|------------------|---|
| Vehicle speed    | More than 30 km/h (19 mph)  |
| Selector lever   | Suitable position   |
| Driving location | Depress the brake pedal for more than 5 seconds so as not to come off from the above-mentioned vehicle speed. |

2. Check 1st trip DTC.

Is 1st trip DTC detected?

- YES >> Proceed to [EC-1468. "Diagnosis Procedure"](#).
- NO >> INSPECTION END

## Diagnosis Procedure

INFOID:000000007784204

### 1. CHECK OVERALL FUNCTION-I

**④ With CONSULT**

1. Turn ignition switch ON.
2. Select "BRAKE SW1" in "DATA MONITOR" mode with CONSULT.
3. Check "BRAKE SW1" indication under the following conditions.

| Monitor item                    | Condition   |                    | Indication |
|---------------------------------|-------------|--------------------|------------|
| BRAKE SW1<br>(ICC brake switch) | Brake pedal | Slightly depressed | OFF        |
|                                 | Brake pedal | Fully released     | ON         |

**⊗ Without CONSULT**

1. Turn ignition switch ON.
2. Check the voltage between ECM harness connector terminals under the following conditions.

| Connector | ECM                              |          | Condition                         | Voltage (V)     |
|-----------|----------------------------------|----------|-----------------------------------|-----------------|
|           | +                                | -        |                                   |                 |
|           | Terminal                         | Terminal |                                   |                 |
| M160      | 147<br>(ICC brake switch signal) | 175      | Brake pedal<br>Slightly depressed | Approx. 0       |
|           |                                  |          | Brake pedal<br>Fully released     | Battery voltage |

Is the inspection result normal?

- YES >> GO TO 2.
- NO >> GO TO 3.

### 2. CHECK OVERALL FUNCTION-II

**④ With CONSULT**

Select "BRAKE SW2" and check indication under the following conditions.

| Monitor item                    | Condition   |                    | Indication |
|---------------------------------|-------------|--------------------|------------|
| BRAKE SW2<br>(Stop lamp switch) | Brake pedal | Slightly depressed | ON         |
|                                 |             | Fully released     | OFF        |

**⊗ Without CONSULT**

Check the voltage between ECM harness connector terminals as per the following.

# P1572 ICC BRAKE SWITCH

< DTC/CIRCUIT DIAGNOSIS >

[VK56VD FOR USA AND CANADA]

| ECM       |                                  |          | Condition   | Voltage (V)        |                 |
|-----------|----------------------------------|----------|-------------|--------------------|-----------------|
| Connector | +                                | -        |             |                    |                 |
|           | Terminal                         | Terminal |             |                    |                 |
| M160      | 158<br>(Stop lamp switch signal) | 175      | Brake pedal | Slightly depressed | Battery voltage |
|           |                                  |          |             | Fully released     | Approx. 0       |

Is the inspection result normal?

YES >> GO TO 14.

NO >> GO TO 8.

## 3. CHECK ICC BRAKE SWITCH POWER SUPPLY CIRCUIT

1. Turn ignition switch OFF.
2. Disconnect ICC brake switch harness connector.
3. Turn ignition switch ON.
4. Check the voltage between ICC brake switch harness connector and ground.

| ICC brake switch |          | Ground | Voltage         |
|------------------|----------|--------|-----------------|
| Connector        | Terminal |        |                 |
| E114             | 1        | Ground | Battery voltage |

Is the inspection result normal?

YES >> GO TO 5.

NO >> GO TO 4.

## 4. DETECT MALFUNCTIONING PART

Check the following.

- Fuse block (J/B) connector E103
- 10 A fuse (No. 3)
- Harness for open or short between ICC brake switch and fuse

>> Repair open circuit or short to ground in harness or connectors.

## 5. CHECK ICC BRAKE SWITCH INPUT SIGNAL CIRCUIT FOR OPEN AND SHORT

1. Turn ignition switch OFF.
2. Disconnect ECM harness connector.
3. Check the continuity between ICC brake switch harness connector and ECM harness connector.

| ICC brake switch |          | ECM       |          | Continuity |
|------------------|----------|-----------|----------|------------|
| Connector        | Terminal | Connector | Terminal |            |
| E114             | 2        | M160      | 147      | Existed    |

4. Also check harness for short to ground and short to power.

Is the inspection result normal?

YES >> GO TO 7.

NO >> GO TO 6.

## 6. DETECT MALFUNCTIONING PART

Check the following.

- Harness for open or short between ICC brake switch and ECM

>> Repair open circuit, short to ground or short to power in harness or connectors.

## 7. CHECK ICC BRAKE SWITCH

Refer to [EC-1471, "Component Inspection \(ICC Brake Switch\)"](#).

Is the inspection result normal?

# P1572 ICC BRAKE SWITCH

[VK56VD FOR USA AND CANADA]

## < DTC/CIRCUIT DIAGNOSIS >

YES >> GO TO 14.

NO >> Replace ICC brake switch. Refer to [BR-18, "Exploded View"](#).

### 8. CHECK STOP LAMP SWITCH POWER SUPPLY CIRCUIT

1. Turn ignition switch OFF.
2. Disconnect stop lamp switch harness connector.
3. Disconnect ICC brake hold relay harness connector.
4. Check the voltage between stop lamp switch harness connector and ground.

| Stop lamp switch |          | Ground | Voltage         |
|------------------|----------|--------|-----------------|
| Connector        | Terminal |        |                 |
| E110             | 1        | Ground | Battery voltage |

5. Check the voltage between ICC brake hold relay harness connector and ground.

| ICC brake hold relay |          | Ground | Voltage         |
|----------------------|----------|--------|-----------------|
| Connector            | Terminal |        |                 |
| E92                  | 5        | Ground | Battery voltage |

Is the inspection result normal?

YES >> GO TO 10.

NO >> GO TO 9.

### 9. DETECT MALFUNCTIONING PART

Check the following.

- Fuse block (J/B) connector E103
- 10 A fuse (No. 7)
- Harness for open or short between battery and stop lamp switch
- Harness for open or short between battery and ICC brake hold relay

>> Repair open circuit or short to ground in harness or connectors.

### 10. CHECK STOP LAMP SWITCH INPUT SIGNAL CIRCUIT FOR OPEN AND SHORT

1. Disconnect ECM harness connector.
2. Check the continuity between stop lamp switch harness connector and ECM harness connector.

| Stop lamp switch |          | ECM       |          | Continuity |
|------------------|----------|-----------|----------|------------|
| Connector        | Terminal | Connector | Terminal |            |
| E110             | 2        | M160      | 158      | Existed    |

3. Check the continuity between ICC brake hold relay harness connector and ECM harness connector.

| ICC brake hold relay |          | ECM       |          | Continuity |
|----------------------|----------|-----------|----------|------------|
| Connector            | Terminal | Connector | Terminal |            |
| E92                  | 3        | M160      | 158      | Existed    |

4. Also check harness for short to ground and short to power.

Is the inspection result normal?

YES >> GO TO 12.

NO >> GO TO 11.

### 11. DETECT MALFUNCTIONING PART

Check the following.

- Fuse block (J/B) connector E103, M2
- Harness for open or short between ECM and stop lamp switch
- Harness for open or short between ECM and ICC brake hold relay

# P1572 ICC BRAKE SWITCH

[VK56VD FOR USA AND CANADA]

< DTC/CIRCUIT DIAGNOSIS >

>> Repair open circuit, short to ground or short to power in harness or connectors.

## 12.CHECK STOP LAMP SWITCH

Refer to [EC-1471, "Component Inspection \(Stop Lamp Switch\)"](#).

Is the inspection result normal?

YES >> GO TO 13.

NO >> Replace stop lamp switch. Refer to [BR-18, "Exploded View"](#).

## 13.CHECK ICC BRAKE HOLD RELAY

Refer to [EC-1472, "Component Inspection \(ICC Brake Hold Relay\)"](#).

Is the inspection result normal?

YES >> GO TO 14.

NO >> Replace ICC brake hold relay.

## 14.CHECK INTERMITTENT INCIDENT

Refer to [GI-44, "Intermittent Incident"](#).

>> INSPECTION END

## Component Inspection (ICC Brake Switch)

INFOID:000000007784205

### 1.CHECK ICC BRAKE SWITCH-I

1. Turn ignition switch OFF.
2. Disconnect ICC brake switch harness connector.
3. Check the continuity between ICC brake switch terminals under the following conditions.

| Terminals | Condition   |                    | Continuity  |
|-----------|-------------|--------------------|-------------|
| 1 and 2   | Brake pedal | Fully released     | Existed     |
|           |             | Slightly depressed | Not existed |

Is the inspection result normal?

YES >> INSPECTION END

NO >> GO TO 2.

### 2.CHECK ICC BRAKE SWITCH-II

1. Adjust ICC brake switch installation. Refer to [BR-7, "Inspection and Adjustment"](#).
2. Check the continuity between ICC brake switch terminals under the following conditions.

| Terminals | Condition   |                    | Continuity  |
|-----------|-------------|--------------------|-------------|
| 1 and 2   | Brake pedal | Fully released     | Existed     |
|           |             | Slightly depressed | Not existed |

Is the inspection result normal?

YES >> INSPECTION END

NO >> Replace ICC brake switch. Refer to [BR-18, "Exploded View"](#).

## Component Inspection (Stop Lamp Switch)

INFOID:000000007784206

### 1.CHECK STOP LAMP SWITCH-I

1. Turn ignition switch OFF.
2. Disconnect stop lamp switch harness connector.
3. Check the continuity between stop lamp switch terminals under the following conditions.

| Terminals | Condition   |                    | Continuity  |
|-----------|-------------|--------------------|-------------|
| 1 and 2   | Brake pedal | Fully released     | Not existed |
|           |             | Slightly depressed | Existed     |

# P1572 ICC BRAKE SWITCH

[VK56VD FOR USA AND CANADA]

< DTC/CIRCUIT DIAGNOSIS >

Is the inspection result normal?

- YES >> INSPECTION END
- NO >> GO TO 2.

## 2.CHECK STOP LAMP SWITCH-II

1. Adjust stop lamp switch installation. Refer to [BR-7, "Inspection and Adjustment"](#).
2. Check the continuity between stop lamp switch terminals under the following conditions.

| Terminals | Condition   |                    | Continuity  |
|-----------|-------------|--------------------|-------------|
| 1 and 2   | Brake pedal | Fully released     | Not existed |
|           |             | Slightly depressed | Existed     |

Is the inspection result normal?

- YES >> INSPECTION END
- NO >> Replace stop lamp switch. Refer to [BR-18, "Exploded View"](#).

## Component Inspection (ICC Brake Hold Relay)

INFOID:000000007793198

### 1.CHECK ICC BRAKE HOLD RELAY

1. Turn ignition switch OFF.
2. Remove ICC brake hold relay.
3. Check the continuity between ICC brake hold relay terminals under the following conditions.

| Terminals | Condition   | Continuity  |
|-----------|---|-------------|
| 3 and 5   | 12V direct current supply between terminals 1 and 2 | Existed     |
|           | No current supply                                   | Not existed |

Is the inspection result normal?

- YES >> INSPECTION END
- NO >> Replace ICC brake hold relay

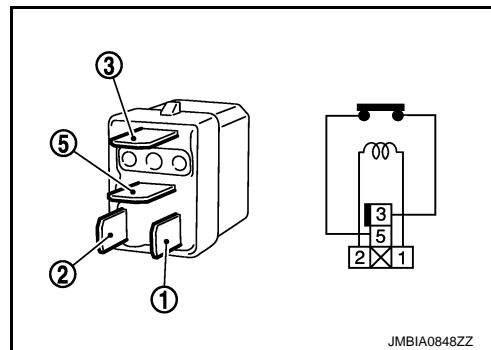

JMBIA0848ZZ



# P1574 ASCD VEHICLE SPEED SENSOR

< DTC/CIRCUIT DIAGNOSIS >

[VK56VD FOR USA AND CANADA]

## P1574 ASCD VEHICLE SPEED SENSOR

### Description

INFOID:000000007187735

The ECM receives two vehicle speed signals by the CAN communication line. One is sent from “combination meter”, and the other is from TCM (Transmission control module). The ECM uses these signals for ASCD control. Refer to [EC-1025, "AUTOMATIC SPEED CONTROL DEVICE \(ASCD\) : System Description"](#) for ASCD functions.

### DTC Logic

INFOID:000000007187736

#### DTC DETECTION LOGIC

##### NOTE:

- If DTC P1574 is displayed with DTC UXXXX, perform the trouble diagnosis for DTC UXXXX.
- If DTC P1574 is displayed with DTC P0500, perform the trouble diagnosis for DTC P0500. Refer to [EC-1365, "DTC Logic"](#).
- If DTC P1574 is displayed with DTC P0605, perform the trouble diagnosis for DTC P0605. Refer to [EC-1384, "DTC Logic"](#).
- If DTC P1574 is displayed with DTC P0607, perform the trouble diagnosis for DTC P0607. Refer to [EC-1386, "DTC Logic"](#).

| DTC No. | Trouble diagnosis name<br>(Trouble diagnosis content) | DTC detecting condition   | Possible cause  |
|---------|---|---|---|
| P1574   | ASCD VHL SPD SEN<br>(ASCD vehicle speed sensor)       | ECM detects a difference between two vehicle speed signals is out of the specified range. | <ul style="list-style-type: none"><li>• Harness or connectors<br/>(The CAN communication line is open or shorted.)</li><li>• Combination meter</li><li>• ABS actuator and electric unit (control unit)</li><li>• Wheel sensor</li><li>• TCM</li><li>• ECM</li></ul> |

#### DTC CONFIRMATION PROCEDURE

##### 1. PRECONDITIONING

1. Turn ignition switch OFF and wait at least 10 seconds.
2. Turn ignition switch ON.
3. Turn ignition switch OFF and wait at least 10 seconds.

>> GO TO 2.

##### 2. PERFORM DTC CONFIRMATION PROCEDURE

1. Start engine (VDC switch OFF).
2. Drive the vehicle at more than 40 km/h (25 MPH).

##### CAUTION:

**Always drive vehicle at a safe speed.**

##### NOTE:

**This procedure may be conducted with the drive wheels lifted in the shop or by driving the vehicle. If a road test is expected to be easier, it is unnecessary to lift the vehicle.**

3. Check DTC.

Is DTC detected?

- YES >> Proceed to [EC-1473, "Diagnosis Procedure"](#).  
NO >> INSPECTION END

### Diagnosis Procedure

INFOID:000000007187737

#### 1. CHECK DTC WITH TCM

Check DTC with TCM. Refer to [TM-60, "CONSULT Function"](#).

Is the inspection result normal?

## P1574 ASCD VEHICLE SPEED SENSOR

[VK56VD FOR USA AND CANADA]

< DTC/CIRCUIT DIAGNOSIS >

---

YES >> GO TO 2.

NO >> Perform Diagnosis Procedure corresponding to the DTC indicated.

### 2.CHECK DTC WITH “ABS ACTUATOR AND ELECTRIC UNIT (CONTROL UNIT)”

---

Refer to [BRC-40. "CONSULT Function"](#).

Is the inspection result normal?

YES >> GO TO 3.

NO >> Perform Diagnosis Procedure corresponding to the DTC indicated.

### 3.CHECK DTC WITH “COMBINATION METER”

---

Refer to [MWI-31. "CONSULT Function"](#).

>> INSPECTION END

# P1574 ICC VEHICLE SPEED SENSOR

< DTC/CIRCUIT DIAGNOSIS >

[VK56VD FOR USA AND CANADA]

## P1574 ICC VEHICLE SPEED SENSOR

### Description

INFOID:000000007187738

The ECM receives two vehicle speed signals by the CAN communication line. One is sent from “combination meter”, and the other is from TCM (Transmission control module). The ECM uses these signals for ICC control. Refer to [EC-1025, "AUTOMATIC SPEED CONTROL DEVICE \(ASCD\) : System Description"](#) for ICC functions.

### DTC Logic

INFOID:000000007187739

#### DTC DETECTION LOGIC

##### NOTE:

- If DTC P1574 is displayed with DTC UXXXX, first perform the trouble diagnosis for DTC UXXXX.
- If DTC P1574 is displayed with DTC P0500, first perform the trouble diagnosis for DTC P0500. Refer to [EC-1365, "DTC Logic"](#).
- If DTC P1574 is displayed with DTC P0605, first perform the trouble diagnosis for DTC P0605. Refer to [EC-1384, "DTC Logic"](#).
- If DTC P1574 is displayed with DTC P0607, first perform the trouble diagnosis for DTC P0607. Refer to [EC-1386, "DTC Logic"](#).

| DTC No. | Trouble diagnosis name<br>(Trouble diagnosis content) | DTC detecting condition   | Possible cause  |
|---------|---|---|---|
| P1574   | ASCD VHL SPD SEN<br>(ICC vehicle speed sensor)        | ECM detects a difference between two vehicle speed signals is out of the specified range. | <ul style="list-style-type: none"><li>• Harness or connectors<br/>(The CAN communication line is open or shorted.)</li><li>• Combination meter</li><li>• ABS actuator and electric unit (control unit)</li><li>• Wheel sensor</li><li>• TCM</li><li>• ECM</li></ul> |

#### DTC CONFIRMATION PROCEDURE

##### 1. PRECONDITIONING

1. Turn ignition switch OFF and wait at least 10 seconds.
2. Turn ignition switch ON.
3. Turn ignition switch OFF and wait at least 10 seconds.

>> GO TO 2.

##### 2. PERFORM DTC CONFIRMATION PROCEDURE

1. Start engine (VDC switch OFF).
2. Drive the vehicle at more than 40 km/h (25 MPH).

##### CAUTION:

**Always drive vehicle at a safe speed.**

##### NOTE:

**This procedure may be conducted with the drive wheels lifted in the shop or by driving the vehicle. If a road test is expected to be easier, it is unnecessary to lift the vehicle.**

3. Check DTC.

Is DTC detected?

- YES >> Proceed to [EC-1475, "Diagnosis Procedure"](#).  
NO >> INSPECTION END

### Diagnosis Procedure

INFOID:000000007187740

#### 1. CHECK DTC WITH TCM

Check DTC with TCM. Refer to [TM-60, "CONSULT Function"](#).

Is the inspection result normal?

## P1574 ICC VEHICLE SPEED SENSOR

[VK56VD FOR USA AND CANADA]

< DTC/CIRCUIT DIAGNOSIS >

---

YES >> GO TO 2.

NO >> Perform Diagnosis Procedure corresponding to the DTC indicated.

### 2.CHECK DTC WITH “ABS ACTUATOR AND ELECTRIC UNIT (CONTROL UNIT)”

---

Refer to [BRC-40, "CONSULT Function"](#).

Is the inspection result normal?

YES >> GO TO 3.

NO >> Perform Diagnosis Procedure corresponding to the DTC indicated.

### 3.CHECK DTC WITH “COMBINATION METER”

---

Check combination meter function.

Refer to [MWI-31, "CONSULT Function"](#).

>> INSPECTION END

# P1606 VVEL CONTROL MODULE

< DTC/CIRCUIT DIAGNOSIS >

[VK56VD FOR USA AND CANADA]

## P1606 VVEL CONTROL MODULE

### DTC Logic

INFOID:000000007187741

### DTC DETECTION LOGIC

| DTC No. | Trouble diagnosis name<br>(Trouble diagnosis content) | DTC detecting condition   | Possible cause  |
|---------|---|---|---|
| P1606   | VVEL CONTROL MODULE<br>(VVEL control module)          | <ul style="list-style-type: none"><li>VVEL control module calculation function is malfunctioning.</li><li>VVEL EEPROM system is malfunctioning.</li></ul> | <ul style="list-style-type: none"><li>VVEL control module</li></ul> |

### DTC CONFIRMATION PROCEDURE

#### 1. PRECONDITIONING

- Turn ignition switch OFF and wait at least 10 seconds.
- Turn ignition switch ON.
- Turn ignition switch OFF and wait at least 10 seconds.

#### TESTING CONDITION:

Before performing the following procedure, confirm that battery voltage is 10 V or more at idle.

>> GO TO 2.

#### 2. PERFORM DTC CONFIRMATION PROCEDURE

- Turn ignition switch ON and wait at least 1 second.
- Check DTC.

#### Is DTC detected?

- YES >> Proceed to [EC-1477, "Diagnosis Procedure"](#).  
NO >> INSPECTION END

### Diagnosis Procedure

INFOID:000000007187742

#### 1. PERFORM DTC CONFIRMATION PROCEDURE

- Turn ignition switch ON.
- Erase DTC.
- Perform DTC Confirmation Procedure.  
See [EC-1477, "DTC Logic"](#).

#### Is the DTC P1606 displayed again?

- YES >> GO TO 2.  
NO >> INSPECTION END

#### 2. REPLACE VVEL CONTROL MODULE

- Replace VVEL control module. Refer to [EC-1554, "Removal and Installation"](#).
- Perform additional service when replacing VVEL control module. Refer to [EC-1118, "Work Procedure"](#).

>> INSPECTION END

# P1607 VVEL CONTROL MODULE

< DTC/CIRCUIT DIAGNOSIS >

[VK56VD FOR USA AND CANADA]

## P1607 VVEL CONTROL MODULE

### DTC Logic

INFOID:000000007187743

### DTC DETECTION LOGIC

| DTC No. | Trouble diagnosis name<br>(Trouble diagnosis content) | DTC detecting condition  | Possible cause  |
|---------|---|--|---|
| P1607   | VVEL CONTROL MODULE<br>(VVEL control module circuit)  | <ul style="list-style-type: none"><li>The internal circuit of the VVEL control module is malfunctioning.</li></ul> | <ul style="list-style-type: none"><li>VVEL control module</li></ul> |

### DTC CONFIRMATION PROCEDURE

#### 1. PRECONDITIONING

- Turn ignition switch OFF and wait at least 10 seconds.
- Turn ignition switch ON.
- Turn ignition switch OFF and wait at least 10 seconds.

#### TESTING CONDITION:

Before performing the following procedure, confirm that battery voltage is 10 V or more at idle.

>> GO TO 2.

#### 2. PERFORM DTC CONFIRMATION PROCEDURE

- Start engine and let it idle for at least 1 second.
- Check DTC.

#### Is DTC detected?

YES >> Proceed to [EC-1478, "Diagnosis Procedure"](#).

NO >> INSPECTION END

### Diagnosis Procedure

INFOID:000000007187744

#### 1. PERFORM DTC CONFIRMATION PROCEDURE

- Turn ignition switch ON.
- Erase DTC.
- Perform DTC Confirmation Procedure.  
See [EC-1478, "DTC Logic"](#).

#### Is the DTC P1607 displayed again?

YES >> GO TO 2.

NO >> INSPECTION END

#### 2. REPLACE VVEL CONTROL MODULE

- Replace VVEL control module. Refer to [EC-1554, "Removal and Installation"](#).
- Perform additional service when replacing VVEL control module. Refer to [EC-1118, "Work Procedure"](#).

>> INSPECTION END

# P1608 VVEL SENSOR POWER SUPPLY

< DTC/CIRCUIT DIAGNOSIS >

[VK56VD FOR USA AND CANADA]

## P1608 VVEL SENSOR POWER SUPPLY

### DTC Logic

INFOID:000000007187745

### DTC DETECTION LOGIC

| DTC No. | Trouble diagnosis name<br>(Trouble diagnosis content)        | DTC detecting condition  | Possible cause   |
|---------|--|--|--|
| P1608   | VVEL SENSOR POWER/CIRC<br>(VVEL sensor power supply circuit) | VVEL control module detects a voltage of power source for sensor is excessively low or high. | <ul style="list-style-type: none"><li>• Harness or connectors (VVEL control shaft position sensor power supply circuit is open or shorted.)</li><li>• VVEL control shaft position sensor</li><li>• VVEL control module</li></ul> |

### DTC CONFIRMATION PROCEDURE

#### 1. PRECONDITIONING

1. Turn ignition switch OFF and wait at least 10 seconds.
2. Turn ignition switch ON.
3. Turn ignition switch OFF and wait at least 10 seconds.

#### TESTING CONDITION:

Before performing the following procedure, confirm that battery voltage is 10 V or more at idle.

>> GO TO 2.

#### 2. PERFORM DTC CONFIRMATION PROCEDURE

1. Turn ignition switch ON and wait at least 1 second.
2. Check DTC.

#### Is DTC detected?

YES >> Proceed to [EC-1479, "Diagnosis Procedure"](#).

NO >> INSPECTION END

### Diagnosis Procedure

INFOID:000000007187746

#### 1. CHECK VVEL CONTROL SHAFT POSITION SENSOR POWER SUPPLY CIRCUIT-I

1. Disconnect VVEL control shaft position sensor harness connector.
2. Turn ignition switch ON.
3. Check the voltage between VVEL control shaft position sensor harness connector and ground.

| VVEL control shaft position sensor |           |          | Ground | Voltage     |
|------------------------------------|-----------|----------|--------|-------------|
| Bank                               | Connector | Terminal |        |             |
| 1                                  | F72       | 3        | Ground | Approx. 5 V |
|                                    |           | 6        |        |             |
| 2                                  | F70       | 3        |        |             |
|                                    |           | 6        |        |             |

#### Is the inspection result normal?

YES >> GO TO 6.

NO >> GO TO 2.

#### 2. CHECK VVEL CONTROL SHAFT POSITION SENSOR POWER SUPPLY CIRCUIT-II

1. Turn ignition switch OFF.
2. Disconnect VVEL control module harness connector.
3. Check the continuity between VVEL control shaft position sensor harness connector and VVEL control module harness connector.

# P1608 VVEL SENSOR POWER SUPPLY

< DTC/CIRCUIT DIAGNOSIS >

[VK56VD FOR USA AND CANADA]

| VVEL control shaft position sensor |           |          | VVEL control module |          | Continuity |
|------------------------------------|-----------|----------|---------------------|----------|------------|
| Bank                               | Connector | Terminal | Connector           | Terminal |            |
| 1                                  | F72       | 3        | E15                 | 7        | Existed    |
|                                    |           | 6        |                     | 20       |            |
| 2                                  | F70       | 3        |                     | 9        |            |
|                                    |           | 6        |                     | 22       |            |

4. Also check harness for short to ground and power.

Is the inspection result normal?

YES >> GO TO 4.

NO >> GO TO 3.

## 3. DETECT MALFUNCTIONING PART

Check the following.

- Harness for open or short between VVEL control shaft position sensor and VVEL control module
- Loose or poor connection for each connector and harness

>> Repair open circuit, short to ground or short to power in harness or connectors.

## 4. CHECK INTERMITTENT INCIDENT

Refer to [GI-44, "Intermittent Incident"](#).

Is the inspection result normal?

YES >> GO TO 5.

NO >> Repair or replace.

## 5. REPLACE VVEL CONTROL MODULE

1. Replace VVEL control module. Refer to [EC-1554, "Removal and Installation"](#).

2. Perform additional service when replacing VVEL control module. Refer to [EC-1118, "Work Procedure"](#).

>> INSPECTION END

## 6. CHECK INTERMITTENT INCIDENT

Refer to [GI-44, "Intermittent Incident"](#).

Is the inspection result normal?

YES >> GO TO 7.

NO >> Repair or replace.

## 7. REPLACE VVEL ACTUATOR SUB ASSEMBLY

Replace VVEL actuator sub assembly. Refer to [EM-246, "Exploded View"](#).

>> INSPECTION END



# P1715 INPUT SPEED SENSOR

< DTC/CIRCUIT DIAGNOSIS >

[VK56VD FOR USA AND CANADA]

## P1715 INPUT SPEED SENSOR

### Description

INFOID:000000007187747

ECM receives input speed sensor signal from TCM by the CAN communication line. ECM uses this signal for engine control.

### DTC Logic

INFOID:000000007187748

### DTC DETECTION LOGIC

#### NOTE:

- If DTC P1715 is displayed with DTC UXXXX, perform the trouble diagnosis for DTC UXXXX.
- If DTC P1715 is displayed with DTC P0335, perform the trouble diagnosis for DTC P0335. Refer to [EC-1305, "DTC Logic"](#).
- If DTC P1715 is displayed with DTC P0340, perform the trouble diagnosis for DTC P0340. Refer to [EC-1309, "DTC Logic"](#).
- If DTC P1715 is displayed with DTC P0605, perform the trouble diagnosis for DTC P0605. Refer to [EC-1384, "DTC Logic"](#).
- If DTC P1715 is displayed with DTC P0607, perform the trouble diagnosis for DTC P0607. Refer to [EC-1386, "DTC Logic"](#).

| DTC No. | Trouble diagnosis name<br>(Trouble diagnosis content) | DTC detecting condition  | Possible cause  |
|---------|---|--|---|
| P1715   | IN PULY SPEED<br>[Input speed sensor (TCM output)]    | Input speed sensor signal is different from the theoretical value calculated by ECM from output speed sensor signal and engine rpm signal. | <ul style="list-style-type: none"><li>• Harness or connectors<br/>(The CAN communication line is open or shorted)<br/>(Input speed sensor circuit is open or shorted)</li><li>• TCM</li></ul> |

### Diagnosis Procedure

INFOID:000000007187749

#### 1.CHECK DTC WITH TCM

Check DTC with TCM. Refer to [TM-60, "CONSULT Function"](#).

Is the inspection result normal?

YES >> GO TO 2.

NO >> Perform Diagnosis Procedure corresponding to DTC indicated.

#### 2.REPLACE TCM

Replace TCM. Refer to [TM-181, "Exploded View"](#).

>> INSPECTION END

# P1805 BRAKE SWITCH

< DTC/CIRCUIT DIAGNOSIS >

[VK56VD FOR USA AND CANADA]

## P1805 BRAKE SWITCH

### DTC Logic

INFOID:000000007187750

### DTC DETECTION LOGIC

| DTC No. | Trouble diagnosis name<br>(Trouble diagnosis content) | DTC detecting condition   | Possible cause   |
|---------|---|---|--|
| P1805   | BRAKE SW/CIRCUIT<br>(Brake switch)                    | A brake switch signal is not sent to ECM for extremely long time while the vehicle is being driven. | <ul style="list-style-type: none"> <li>• Harness or connectors (Stop lamp switch circuit is open or shorted.)</li> <li>• Stop lamp switch</li> </ul> |

### DTC CONFIRMATION PROCEDURE

#### 1. PERFORM DTC CONFIRMATION PROCEDURE

1. Turn ignition switch ON.
2. Fully depress the brake pedal for at least 5 seconds.
3. Erase the DTC.
4. Check 1st trip DTC.

#### Is 1st trip DTC detected?

- YES >> Proceed to [EC-1482, "Diagnosis Procedure"](#).  
 NO >> INSPECTION END

### Diagnosis Procedure

INFOID:000000007187751

#### 1. CHECK STOP LAMP SWITCH CIRCUIT

1. Turn ignition switch OFF.
2. Check for stop lamp illumination under the following conditions.

| Condition   |                    | Stop lamp       |
|-------------|--------------------|-----------------|
| Brake pedal | Fully released     | Not illuminated |
|             | Slightly depressed | Illuminated     |

#### Is the inspection result normal?

- YES >> GO TO 4.  
 NO >> GO TO 2.

#### 2. CHECK STOP LAMP SWITCH POWER SUPPLY CIRCUIT

1. Disconnect stop lamp switch harness connector.
2. Check the voltage between stop lamp switch harness connector and ground.

| Stop lamp switch |          | Ground | Voltage         |
|------------------|----------|--------|-----------------|
| Connector        | Terminal |        |                 |
| E110             | 1        | Ground | Battery voltage |

#### Is the inspection result normal?

- YES >> GO TO 4.  
 NO >> GO TO 3.

#### 3. DETECT MALFUNCTIONING PART

Check the following.

- 10 A fuse (No. 7)
- Harness for open or short between stop lamp switch and battery
- Loose or poor connection for each connector and harness

>> Repair open circuit, short to ground or short to power in harness or connectors.

# P1805 BRAKE SWITCH

< DTC/CIRCUIT DIAGNOSIS >

[VK56VD FOR USA AND CANADA]

## 4.CHECK STOP LAMP SWITCH INPUT SIGNAL CIRCUIT FOR OPEN AND SHORT

1. Disconnect stop lamp switch harness connector.
2. Disconnect ECM harness connector.
3. Check the continuity between stop lamp switch harness connector and ECM harness connector.

| Stop lamp switch |          | ECM       |          | Continuity |
|------------------|----------|-----------|----------|------------|
| Connector        | Terminal | Connector | Terminal |            |
| E110             | 2        | M160      | 158      | Existed    |

4. Also check harness for short to ground and short to power.

Is the inspection result normal?

YES >> GO TO 6.

NO >> GO TO 5.

## 5.DETECT MALFUNCTIONING PART

Check the following.

- Harness for open or short between ECM and stop lamp switch
- Loose or poor connection for each connector and harness

>> Repair open circuit, short to ground or short to power in harness or connectors.

## 6.CHECK STOP LAMP SWITCH

Refer to [EC-1483, "Component Inspection \(Stop Lamp Switch\)"](#).

Is the inspection result normal?

YES >> GO TO 7.

NO >> Replace stop lamp switch. Refer to [BR-18, "Exploded View"](#).

## 7.CHECK INTERMITTENT INCIDENT

Refer to [GI-44, "Intermittent Incident"](#).

>> INSPECTION END

## Component Inspection (Stop Lamp Switch)

INFOID:000000007187752

### 1.CHECK STOP LAMP SWITCH-I

1. Turn ignition switch OFF.
2. Disconnect stop lamp switch harness connector.
3. Check the continuity between stop lamp switch terminals under the following conditions.

| Terminals | Condition   |                    | Continuity  |
|-----------|-------------|--------------------|-------------|
| 1 and 2   | Brake pedal | Fully released     | Not existed |
|           |             | Slightly depressed | Existed     |

Is the inspection result normal?

YES >> INSPECTION END

NO >> GO TO 2.

### 2.CHECK STOP LAMP SWITCH-II

1. Adjust stop lamp switch installation. Refer to [BR-19, "Inspection and Adjustment"](#).
2. Check the continuity between stop lamp switch terminals under the following conditions.

| Terminals | Condition   |                    | Continuity  |
|-----------|-------------|--------------------|-------------|
| 1 and 2   | Brake pedal | Fully released     | Not existed |
|           |             | Slightly depressed | Existed     |

Is the inspection result normal?

## P1805 BRAKE SWITCH

< DTC/CIRCUIT DIAGNOSIS >

[VK56VD FOR USA AND CANADA]

---

YES >> INSPECTION END

NO >> Replace stop lamp switch. Refer to [BR-18, "Exploded View"](#).

# P2100, P2103 THROTTLE CONTROL MOTOR RELAY

< DTC/CIRCUIT DIAGNOSIS >

[VK56VD FOR USA AND CANADA]

## P2100, P2103 THROTTLE CONTROL MOTOR RELAY

### DTC Logic

INFOID:000000007187753

### DTC DETECTION LOGIC

| DTC No. | Trouble diagnosis name<br>(Trouble diagnosis content)                     | DTC detecting condition   | Possible cause   |
|---------|---|---|--|
| P2100   | ETC MOT PWR-B1<br>[Throttle control motor relay<br>circuit open (bank 1)] | ECM detects that the voltage of power<br>source for throttle control motor is ex-<br>cessively low. | <ul style="list-style-type: none"><li>• Harness or connectors<br/>(Throttle control motor relay circuit is open)</li><li>• Throttle control motor relay</li></ul>    |
| P2103   | ETC MOT PWR<br>(Throttle control motor relay<br>circuit short)            | ECM detects that the throttle control<br>motor relay is stuck ON.                                   | <ul style="list-style-type: none"><li>• Harness or connectors<br/>(Throttle control motor relay circuit is shorted)</li><li>• Throttle control motor relay</li></ul> |

### DTC CONFIRMATION PROCEDURE

#### 1. PRECONDITIONING

1. Turn ignition switch OFF and wait at least 10 seconds.
2. Turn ignition switch ON.
3. Turn ignition switch OFF and wait at least 10 seconds.

#### TESTING CONDITION:

Before performing the following procedure, confirm that battery voltage is 8 V or more at idle.

#### Which DTC is detected?

P2100 >> GO TO 2.

P2103 >> GO TO 3.

#### 2. PERFORM DTC CONFIRMATION PROCEDURE FOR DTC P2100

1. Turn ignition switch ON and wait at least 2 seconds.
2. Start engine and let it idle for 5 seconds.
3. Check DTC.

#### Is DTC detected?

YES >> Proceed to [EC-1485, "Diagnosis Procedure"](#).

NO >> INSPECTION END

#### 3. PERFORM DTC CONFIRMATION PROCEDURE FOR DTC P2103

1. Turn ignition switch ON and wait at least 1 second.
2. Check DTC.

#### Is DTC detected?

YES >> Proceed to [EC-1485, "Diagnosis Procedure"](#).

NO >> INSPECTION END

### Diagnosis Procedure

INFOID:000000007187754

#### 1. CHECK THROTTLE CONTROL MOTOR RELAY POWER SUPPLY CIRCUIT

1. Turn ignition switch OFF.
2. Disconnect ECM harness connector.
3. Disconnect IPDM E/R harness connector E7.
4. Check the continuity between IPDM E/R harness connector and ECM harness connector.

| IPDM E/R  |          | ECM       |          | Continuity |
|-----------|----------|-----------|----------|------------|
| Connector | Terminal | Connector | Terminal |            |
| E7        | 71       | M160      | 123      | Existed    |

5. Also check harness for short to ground and short to power.

#### Is the inspection result normal?

YES >> GO TO 3.

# P2100, P2103 THROTTLE CONTROL MOTOR RELAY

[VK56VD FOR USA AND CANADA]

< DTC/CIRCUIT DIAGNOSIS >

NO >> GO TO 2.

## 2. DETECT MALFUNCTIONING PART

Check the following.

- Harness for open or short between ECM and IPDM E/R
- Loose or poor connection for each connector and harness

>> Repair open circuit, short to ground or short to power in harness or connectors.

## 3. CHECK THROTTLE CONTROL MOTOR RELAY INPUT SIGNAL CIRCUIT

1. Check the continuity between IPDM E/R sensor harness connector and ECM harness connector.

| DTC   | IPDM E/R  |          | ECM       |          | Continuity |
|-------|-----------|----------|-----------|----------|------------|
|       | Connector | Terminal | Connector | Terminal |            |
| P2100 | E5        | 7        | M160      | 173      | Existed    |
| P2103 |           |          |           |          |            |

2. Also check harness for short to ground and short to power.

Is the inspection result normal?

YES >> GO TO 5.

NO >> GO TO 4.

## 4. DETECT MALFUNCTIONING PART

Check the following.

- Harness for open or short between ECM and IPDM E/R
- Loose or poor connection for each connector and harness

>> Repair open circuit, short to ground or short to power in harness or connectors.

## 5. CHECK FUSE

1. Disconnect 15 A fuse (No. 50) from IPDM E/R.
2. Check if 15 A fuse is blown.

Is the inspection result normal?

YES >> GO TO 6.

NO >> Replace 15 A fuse.

## 6. CHECK INTERMITTENT INCIDENT

Refer to [GI-44, "Intermittent Incident"](#).

Is the inspection result normal?

YES >> Replace IPDM E/R. Refer to [PCS-33, "Removal and Installation"](#).

NO >> Repair or replace harness or connectors.

# P2122, P2123 APP SENSOR

< DTC/CIRCUIT DIAGNOSIS >

[VK56VD FOR USA AND CANADA]

## P2122, P2123 APP SENSOR

### DTC Logic

INFOID:000000007187755

### DTC DETECTION LOGIC

#### NOTE:

If DTC P2122 or P2123 is displayed with DTC P0643, perform the trouble diagnosis for DTC P0643. Refer to [EC-1389, "DTC Logic"](#).

| DTC No. | Trouble diagnosis name<br>(Trouble diagnosis content)                      | DTC detecting condition   | Possible cause  |
|---------|--|---|---|
| P2122   | APP SEN 1/CIRC<br>(Accelerator pedal position sensor 1 circuit low input)  | An excessively low voltage from the APP sensor 1 is sent to ECM.  | <ul style="list-style-type: none"><li>• Harness or connectors (APP sensor 1 circuit is open or shorted.)</li><li>• Accelerator pedal position sensor (APP sensor 1)</li></ul> |
| P2123   | APP SEN 1/CIRC<br>(Accelerator pedal position sensor 1 circuit high input) | An excessively high voltage from the APP sensor 1 is sent to ECM. |   |

### DTC CONFIRMATION PROCEDURE

#### 1. PRECONDITIONING

1. Turn ignition switch OFF and wait at least 10 seconds.
2. Turn ignition switch ON.
3. Turn ignition switch OFF and wait at least 10 seconds.

#### TESTING CONDITION:

Before performing the following procedure, confirm that battery voltage is 8 V or more at idle.

>> GO TO 2.

#### 2. PERFORM DTC CONFIRMATION PROCEDURE

1. Start engine and let it idle for 1 second.
2. Check DTC.

#### Is DTC detected?

- YES >> Proceed to [EC-1487, "Diagnosis Procedure"](#).  
NO >> INSPECTION END

### Diagnosis Procedure

INFOID:000000007187756

#### 1. CHECK ACCELERATOR PEDAL POSITION SENSOR 1 POWER SUPPLY CIRCUIT

1. Disconnect accelerator pedal position (APP) sensor harness connector.
2. Turn ignition switch ON.
3. Check the voltage between APP sensor harness connector and ground.

| APP sensor          |          | Ground | Voltage (V) |
|---------------------|----------|--------|-------------|
| Connector           | Terminal |        |             |
| M9<br>(Without ICC) | 5        | Ground | Approx. 5   |
| M153<br>(With ICC)  | 6        |        |             |

#### Is the inspection result normal?

- YES >> GO TO 3.  
NO >> GO TO 2.

#### 2. DETECT MALFUNCTIONING PART

Check the following.

- Harness for open or short between ECM and APP sensor
- Loose or poor connection for each connector and harness

## P2122, P2123 APP SENSOR

< DTC/CIRCUIT DIAGNOSIS >

[VK56VD FOR USA AND CANADA]

>> Repair open circuit, short to ground or short to power in harness or connectors.

### 3. CHECK APP SENSOR 1 GROUND CIRCUIT FOR OPEN AND SHORT

1. Turn ignition switch OFF.
2. Disconnect ECM harness connector.
3. Check the continuity between APP sensor harness connector and ECM harness connector.

| APP sensor          |          | ECM       |          | Continuity |
|---------------------|----------|-----------|----------|------------|
| Connector           | Terminal | Connector | Terminal |            |
| M9<br>(Without ICC) | 4        | M160      | 140      | Existed    |
| M153<br>(With ICC)  | 5        |           |          |            |

4. Also check harness for short to ground and short to power.

Is the inspection result normal?

- YES >> GO TO 5.  
NO >> GO TO 4.

### 4. DETECT MALFUNCTIONING PART

Check the following.

- Harness for open or short between ECM and APP sensor
- Loose or poor connection for each connector and harness

>> Repair open circuit, short to ground or short to power in harness or connectors.

### 5. CHECK APP SENSOR INPUT SIGNAL CIRCUIT FOR OPEN AND SHORT

1. Check the continuity between APP sensor harness connector and ECM harness connector.

| APP sensor          |          | ECM       |          | Continuity |
|---------------------|----------|-----------|----------|------------|
| Connector           | Terminal | Connector | Terminal |            |
| M9<br>(Without ICC) | 3        | M160      | 136      | Existed    |
| M153<br>(With ICC)  | 4        |           |          |            |

2. Also check harness for short to ground and short to power.

Is the inspection result normal?

- YES >> GO TO 7.  
NO >> GO TO 6.

### 6. DETECT MALFUNCTIONING PART

Check the following.

- Loose or poor connection for each connector and harness
- Harness for open or short between ECM and APP sensor

>> Repair open circuit, short to ground or short to power in harness or connectors.

### 7. CHECK APP SENSOR

Refer to [EC-1489, "Component Inspection \(Accelerator Pedal Position Sensor\)"](#).

Is the inspection result normal?

- YES >> GO TO 9.  
NO >> GO TO 8.

### 8. REPLACE ACCELERATOR PEDAL ASSEMBLY

Replace accelerator pedal assembly.



# P2122, P2123 APP SENSOR

[VK56VD FOR USA AND CANADA]

< DTC/CIRCUIT DIAGNOSIS >

Refer to [ACC-3. "MODELS WITHOUT DISTANCE CONTROL ASSIST SYSTEM : Removal and Installation"](#) (Without distance control assist system).

Refer to [ACC-4. "MODELS WITH DISTANCE CONTROL ASSIST SYSTEM : Removal and Installation"](#) (With distance control assist system).

>> INSPECTION END

## 9. CHECK INTERMITTENT INCIDENT

Refer to [GI-44. "Intermittent Incident"](#).

>> INSPECTION END

## Component Inspection (Accelerator Pedal Position Sensor)

INFOID:000000007187757

### 1. CHECK ACCELERATOR PEDAL POSITION SENSOR

1. Turn ignition switch OFF.
2. Reconnect all harness connectors disconnected.
3. Turn ignition switch ON.
4. Check the voltage ECM harness connector terminals under the following conditions.

| ECM       |                    |          | Condition       | Voltage (V) |
|-----------|--------------------|----------|-----------------|-------------|
| Connector | +                  | -        |                 |             |
|           | Terminal           | Terminal |                 |             |
| M160      | 136 (APP sensor 1) | 140      | Fully released  | 0.45 - 1.0  |
|           |                    |          | Fully depressed | 4.4 - 4.8   |
|           | 126 (APP sensor 2) | 129      | Fully released  | 0.22 - 0.5  |
|           |                    |          | Fully depressed | 2.1 - 2.5   |

Is the inspection result normal?

YES >> INSPECTION END

NO >> GO TO 2.

### 2. REPLACE ACCELERATOR PEDAL ASSEMBLY

Replace accelerator pedal assembly.

Refer to [ACC-3. "MODELS WITHOUT DISTANCE CONTROL ASSIST SYSTEM : Removal and Installation"](#) (Without distance control assist system).

Refer to [ACC-4. "MODELS WITH DISTANCE CONTROL ASSIST SYSTEM : Removal and Installation"](#) (With distance control assist system).

>> INSPECTION END

# P2127, P2128 APP SENSOR

< DTC/CIRCUIT DIAGNOSIS >

[VK56VD FOR USA AND CANADA]

## P2127, P2128 APP SENSOR

### DTC Logic

INFOID:000000007187758

### DTC DETECTION LOGIC

| DTC No. | Trouble diagnosis name<br>(Trouble diagnosis content)                      | DTC detecting condition   | Possible cause  |
|---------|--|---|---|
| P2127   | APP SEN 2/CIRC<br>(Accelerator pedal position sensor 2 circuit low input)  | An excessively low voltage from the APP sensor 2 is sent to ECM.  | <ul style="list-style-type: none"><li>• Harness or connectors<br/>(Accelerator pedal position sensor 2 circuit is shorted.)<br/>(Battery current sensor circuit is shorted.)<br/>(Crankshaft position sensor circuit is open or shorted.)<br/>[Camshaft position sensor (bank 1) circuit is shorted.]<br/>(EVAP control system pressure sensor circuit is shorted.)<br/>(Refrigerant pressure sensor circuit is shorted.)</li><li>• Accelerator pedal position sensor 2</li><li>• Battery current sensor</li><li>• Crankshaft position sensor</li><li>• Camshaft position sensor (bank 1)</li><li>• EVAP control system pressure sensor</li><li>• Refrigerant pressure sensor</li></ul> |
| P2128   | APP SEN 2/CIRC<br>(Accelerator pedal position sensor 2 circuit high input) | An excessively high voltage from the APP sensor 2 is sent to ECM. |   |

### DTC CONFIRMATION PROCEDURE

#### 1. PRECONDITIONING

1. Turn ignition switch OFF and wait at least 10 seconds.
2. Turn ignition switch ON.
3. Turn ignition switch OFF and wait at least 10 seconds.

#### TESTING CONDITION:

Before performing the following procedure, confirm that battery voltage is 8 V or more at idle.

>> GO TO 2.

#### 2. PERFORM DTC CONFIRMATION PROCEDURE

1. Start engine and let it idle for 1 second.
2. Check DTC.

#### Is DTC detected?

- YES >> Proceed to [EC-1490. "Diagnosis Procedure"](#).  
NO >> INSPECTION END

### Diagnosis Procedure

INFOID:000000007187759

#### 1. CHECK ACCELERATOR PEDAL POSITION SENSOR 2 POWER SUPPLY CIRCUIT-I

1. Disconnect accelerator pedal position (APP) sensor harness connector.
2. Turn ignition switch ON.
3. Check the voltage between APP sensor harness connector and ground.

| APP sensor          |          | Ground | Voltage (V) |
|---------------------|----------|--------|-------------|
| Connector           | Terminal |        |             |
| M9<br>(Without ICC) | 6        | Ground | Approx. 5 V |
| M153<br>(With ICC)  | 3        |        |             |

#### Is the inspection result normal?

- YES >> GO TO 6.

# P2127, P2128 APP SENSOR

[VK56VD FOR USA AND CANADA]

< DTC/CIRCUIT DIAGNOSIS >

NO >> GO TO 2.

## 2.CHECK APP SENSOR 2 POWER SUPPLY CIRCUIT-II

1. Turn ignition switch OFF.
2. Disconnect ECM harness connector.
3. Check the continuity between APP sensor harness connector and ECM harness connector.

| APP sensor          |          | ECM       |          | Continuity |
|---------------------|----------|-----------|----------|------------|
| Connector           | Terminal | Connector | Terminal |            |
| M9<br>(Without ICC) | 6        | M160      | 131      | Existed    |
| M153<br>(With ICC)  | 3        |           |          |            |

Is the inspection result normal?

YES >> GO TO 4.

NO >> GO TO 3.

## 3.DETECT MALFUNCTIONING PART

Check the following.

- Loose or poor connection for each connector and harness
- Harness for open or short between ECM and APP sensor

>> Repair open circuit.

## 4.CHECK SENSOR POWER SUPPLY CIRCUIT

Check harness for short to power and short to ground, between the following terminals.

| ECM       |          | Sensor                              |           |          |
|-----------|----------|-------------------------------------|-----------|----------|
| Connector | Terminal | Name                                | Connector | Terminal |
| F111      | 76       | CKP sensor                          | F2        | 1        |
|           | 77       | Camshaft position sensor (bank 1)   | F84       | 1        |
| M160      | 133      | Battery current sensor              | E21       | 1        |
|           | 133      | EVAP control system pressure sensor | B73       | 3        |
|           | 133      | Refrigerant pressure sensor         | E77       | 3        |
|           | 131      | APP sensor 2 (Without ICC)          | M9        | 6        |
|           | 131      | APP sensor 2 (With ICC)             | M153      | 3        |

Is the inspection result normal?

YES >> GO TO 5.

NO >> Repair short to ground or short to power in harness or connectors.

## 5.CHECK COMPONENTS

Check the following.

- CKP sensor (Refer to [EC-1307, "Component Inspection \(Crankshaft Position Sensor\)"](#).)
- Camshaft position sensor (bank 1) (Refer to [EC-1312, "Component Inspection \(Camshaft Position Sensor\)"](#).)
- Battery current sensor (Refer to [EC-1438, "Component Inspection \(Battery Current Sensor\)"](#).)
- EVAP control system pressure sensor (Refer to [EC-1343, "Component Inspection \(EVAP Control System Pressure Sensor\)"](#).)
- Refrigerant pressure sensor (Refer to [EC-1539, "Diagnosis Procedure"](#).)

Is the inspection result normal?

YES >> GO TO 12.

NO >> Replace malfunctioning component.

## 6.CHECK APP SENSOR 2 GROUND CIRCUIT FOR OPEN AND SHORT

## P2127, P2128 APP SENSOR

< DTC/CIRCUIT DIAGNOSIS >

[VK56VD FOR USA AND CANADA]

1. Turn ignition switch OFF.
2. Disconnect ECM harness connector.
3. Check the continuity between APP sensor harness connector and ECM harness connector.

| APP sensor          |          | ECM       |          | Continuity |
|---------------------|----------|-----------|----------|------------|
| Connector           | Terminal | Connector | Terminal |            |
| M9<br>(Without ICC) | 2        | M160      | 129      | Existed    |
| M153<br>(With ICC)  | 2        |           |          |            |

4. Also check harness for short to ground and short to power.

Is the inspection result normal?

YES >> GO TO 8.

NO >> GO TO 7.

### 7. DETECT MALFUNCTIONING PART

Check the following.

- Loose or poor connection for each connector and harness
- Harness for open or short between ECM and APP sensor

>> Repair open circuit, short to ground or short to power in harness or connectors.

### 8. CHECK APP SENSOR 2 INPUT SIGNAL CIRCUIT FOR OPEN AND SHORT

1. Check the continuity between APP sensor harness connector and ECM harness connector.

| APP sensor          |          | ECM       |          | Continuity |
|---------------------|----------|-----------|----------|------------|
| Connector           | Terminal | Connector | Terminal |            |
| M9<br>(Without ICC) | 1        | M160      | 126      | Existed    |
| M153<br>(With ICC)  | 1        |           |          |            |

2. Also check harness for short to ground and short to power.

Is the inspection result normal?

YES >> GO TO 10.

NO >> GO TO 9.

### 9. DETECT MALFUNCTIONING PART

Check the following.

- Harness for open or short between ECM and APP sensor
- Loose or poor connection for each connector and harness

>> Repair open circuit, short to ground or short to power in harness or connectors.

### 10. CHECK APP SENSOR

Refer to [EC-1497, "Component Inspection \(Accelerator Pedal Position Sensor\)"](#).

Is the inspection result normal?

YES >> GO TO 12.

NO >> GO TO 11.

### 11. REPLACE ACCELERATOR PEDAL ASSEMBLY

Replace accelerator pedal assembly.

Refer to [ACC-3, "MODELS WITHOUT DISTANCE CONTROL ASSIST SYSTEM : Removal and Installation"](#) (Without distance control assist system).

Refer to [ACC-4, "MODELS WITH DISTANCE CONTROL ASSIST SYSTEM : Removal and Installation"](#) (With distance control assist system).

>> INSPECTION END

**12. CHECK INTERMITTENT INCIDENT**

Refer to [GI-44. "Intermittent Incident"](#).

>> INSPECTION END

**Component Inspection (Accelerator Pedal Position Sensor)**

INFOID:000000007187760

**1. CHECK ACCELERATOR PEDAL POSITION SENSOR**

1. Turn ignition switch OFF.
2. Reconnect all harness connectors disconnected.
3. Turn ignition switch ON.
4. Check the voltage ECM harness connector terminals under the following conditions.

| Connector | ECM                |          | Condition       | Voltage (V) |
|-----------|--------------------|----------|-----------------|-------------|
|           | +                  | -        |                 |             |
|           | Terminal           | Terminal |                 |             |
| M160      | 136 (APP sensor 1) | 140      | Fully released  | 0.45 - 1.0  |
|           |                    |          | Fully depressed | 4.4 - 4.8   |
|           | 126 (APP sensor 2) | 129      | Fully released  | 0.22 - 0.5  |
|           |                    |          | Fully depressed | 2.1 - 2.5   |

Is the inspection result normal?

- YES >> INSPECTION END  
 NO >> GO TO 2.

**2. REPLACE ACCELERATOR PEDAL ASSEMBLY**

Replace accelerator pedal assembly.

Refer to [ACC-3. "MODELS WITHOUT DISTANCE CONTROL ASSIST SYSTEM : Removal and Installation"](#) (Without distance control assist system).

Refer to [ACC-4. "MODELS WITH DISTANCE CONTROL ASSIST SYSTEM : Removal and Installation"](#) (With distance control assist system).

>> INSPECTION END

# P2138 APP SENSOR

[VK56VD FOR USA AND CANADA]

< DTC/CIRCUIT DIAGNOSIS >

## P2138 APP SENSOR

### DTC Logic

INFOID:000000007187761

### DTC DETECTION LOGIC

**NOTE:**

If DTC P2138 is displayed with DTC P0643, first perform the trouble diagnosis for DTC P0643. Refer to [EC-1389, "DTC Logic"](#).

| DTC No. | Trouble diagnosis name<br>(Trouble diagnosis content)                       | DTC detecting condition   | Possible cause  |
|---------|---|---|---|
| P2138   | APP SENSOR<br>(Accelerator pedal position sensor circuit range/performance) | Rationally incorrect voltage is sent to ECM compared with the signals from APP sensor 1 and APP sensor 2. | <ul style="list-style-type: none"> <li>• Harness or connectors<br/>(APP sensor 1 or 2 circuit is open or shorted.)<br/>(Battery current sensor circuit is shorted.)<br/>(Crankshaft position sensor circuit is open or shorted.)<br/>[Camshaft position sensor (bank 1) circuit is shorted.]<br/>(EVAP control system pressure sensor circuit is shorted.)<br/>(Refrigerant pressure sensor circuit is shorted.)</li> <li>• Accelerator pedal position sensor (APP sensor 1 or 2)</li> <li>• Battery current sensor</li> <li>• Crankshaft position sensor</li> <li>• Camshaft position sensor (bank 1)</li> <li>• EVAP control system pressure sensor</li> <li>• Refrigerant pressure sensor</li> </ul> |

### DTC CONFIRMATION PROCEDURE

#### 1. PRECONDITIONING

1. Turn ignition switch OFF and wait at least 10 seconds.
2. Turn ignition switch ON.
3. Turn ignition switch OFF and wait at least 10 seconds.

**TESTING CONDITION:**

Before performing the following procedure, confirm that battery voltage is 8 V or more at idle.

>> GO TO 2.

#### 2. PERFORM DTC CONFIRMATION PROCEDURE

1. Start engine and let it idle for 1 second.
2. Check DTC.

Is DTC detected?

YES >> Proceed to [EC-1494, "Diagnosis Procedure"](#).

NO >> INSPECTION END

### Diagnosis Procedure

INFOID:000000007187762

#### 1. CHECK ACCELERATOR PEDAL POSITION SENSOR 1 POWER SUPPLY CIRCUIT

1. Disconnect accelerator pedal position (APP) sensor harness connector.
2. Turn ignition switch ON.
3. Check the voltage between APP sensor harness connector and ground.

| APP sensor          |          | Ground | Voltage (V) |
|---------------------|----------|--------|-------------|
| Connector           | Terminal |        |             |
| M9<br>(Without ICC) | 5        | Ground | Approx. 5   |
| M153<br>(With ICC)  | 6        |        |             |

Is the inspection result normal?

# P2138 APP SENSOR

[VK56VD FOR USA AND CANADA]

## < DTC/CIRCUIT DIAGNOSIS >

- YES >> GO TO 3.
- NO >> GO TO 2.

### 2. DETECT MALFUNCTIONING PART

Check the following.

- Loose or poor connection for each connector and harness
- Harness for open or short between ECM and APP sensor

>> Repair open circuit, short to ground or short to power in harness or connectors.

### 3. CHECK APP SENSOR 2 POWER SUPPLY CIRCUIT-I

1. Turn ignition switch ON.
2. Check the voltage between APP sensor harness connector and ground.

| APP sensor          |          | Ground | Voltage (V) |
|---------------------|----------|--------|-------------|
| Connector           | Terminal |        |             |
| M9<br>(Without ICC) | 6        | Ground | Approx. 5   |
| M153<br>(With ICC)  | 3        |        |             |

Is the inspection result normal?

- YES >> GO TO 8.
- NO >> GO TO 4.

### 4. CHECK APP SENSOR 2 POWER SUPPLY CIRCUIT-II

1. Turn ignition switch OFF.
2. Disconnect ECM harness connector.
3. Check the continuity between APP sensor harness connector and ECM harness connector.

| APP sensor          |          | ECM       |          | Continuity |
|---------------------|----------|-----------|----------|------------|
| Connector           | Terminal | Connector | Terminal |            |
| M9<br>(Without ICC) | 6        | M160      | 131      | Existed    |
| M153<br>(With ICC)  | 3        |           |          |            |

Is the inspection result normal?

- YES >> GO TO 6.
- NO >> GO TO 5.

### 5. DETECT MALFUNCTIONING PART

Check the following.

- Harness for open or short between ECM and accelerator pedal position sensor
- Loose or poor connection for each connector and harness

>> Repair open circuit.

### 6. CHECK SENSOR POWER SUPPLY CIRCUIT

Check harness for short to power and short to ground, between the following terminals.

| ECM       |          | Sensor                            |           |          |
|-----------|----------|-----------------------------------|-----------|----------|
| Connector | Terminal | Name                              | Connector | Terminal |
| F111      | 76       | CKP sensor                        | F2        | 1        |
|           | 77       | Camshaft position sensor (bank 1) | F84       | 1        |

# P2138 APP SENSOR

< DTC/CIRCUIT DIAGNOSIS >

[VK56VD FOR USA AND CANADA]

| ECM       |          | Sensor                              |           |          |
|-----------|----------|-------------------------------------|-----------|----------|
| Connector | Terminal | Name                                | Connector | Terminal |
| M160      | 133      | Battery current sensor              | E21       | 1        |
|           | 133      | EVAP control system pressure sensor | B73       | 3        |
|           | 133      | Refrigerant pressure sensor         | E77       | 3        |
|           | 137      | APP sensor 1 (Without ICC)          | M9        | 5        |
|           | 137      | APP sensor 1 (With ICC)             | M153      | 6        |
|           | 131      | APP sensor 2 (Without ICC)          | M9        | 6        |
|           | 131      | APP sensor 2 (With ICC)             | M153      | 3        |

Is the inspection result normal?

YES >> GO TO 7.

NO >> Repair short to ground or short to power in harness or connectors.

## 7. CHECK COMPONENTS

Check the following.

- CKP sensor (Refer to [EC-1307, "Component Inspection \(Crankshaft Position Sensor\)"](#).)
- Camshaft position sensor (bank 1) (Refer to [EC-1312, "Component Inspection \(Camshaft Position Sensor\)"](#).)
- Battery current sensor (Refer to [EC-1438, "Component Inspection \(Battery Current Sensor\)"](#).)
- EVAP control system pressure sensor (Refer to [EC-1343, "Component Inspection \(EVAP Control System Pressure Sensor\)"](#).)
- Refrigerant pressure sensor (Refer to [EC-1539, "Diagnosis Procedure"](#).)

Is the inspection result normal?

YES >> GO TO 14.

NO >> Replace malfunctioning component.

## 8. CHECK APP SENSOR GROUND CIRCUIT FOR OPEN AND SHORT

1. Turn ignition switch OFF.
2. Disconnect ECM harness connector.
3. Check the continuity between APP sensor harness connector and ECM harness connector.

| APP sensor          |          | ECM       |          | Continuity |
|---------------------|----------|-----------|----------|------------|
| Connector           | Terminal | Connector | Terminal |            |
| M9<br>(Without ICC) | 4        | M160      | 140      | Existed    |
|                     | 2        |           | 129      |            |
| M153<br>(With ICC)  | 5        | M160      | 140      | Existed    |
|                     | 2        |           | 129      |            |

4. Also check harness for short to ground and short to power.

Is the inspection result normal?

YES >> GO TO 10.

NO >> GO TO 9.

## 9. DETECT MALFUNCTIONING PART

Check the following.

- Harness for open or short between ECM and accelerator pedal position sensor
- Loose or poor connection for each connector and harness

>> Repair open circuit, short to ground or short to power in harness or connectors.

## 10. CHECK APP SENSOR INPUT SIGNAL CIRCUIT FOR OPEN AND SHORT

1. Check the continuity between APP sensor harness connector and ECM harness connector.



# P2138 APP SENSOR

< DTC/CIRCUIT DIAGNOSIS >

[VK56VD FOR USA AND CANADA]

| APP sensor          |          | ECM       |          | Continuity |
|---------------------|----------|-----------|----------|------------|
| Connector           | Terminal | Connector | Terminal |            |
| M9<br>(Without ICC) | 3        | M160      | 136      | Existed    |
|                     | 1        |           | 126      |            |
| M153<br>(With ICC)  | 4        | M160      | 136      | Existed    |
|                     | 1        |           | 126      |            |

2. Also check harness for short to ground and short to power.

Is the inspection result normal?

YES >> GO TO 12.

NO >> GO TO 11.

## 11. DETECT MALFUNCTIONING PART

Check the following.

- Harness for open or short between ECM and accelerator pedal position sensor
- Loose or poor connection for each connector and harness

>> Repair open circuit, short to ground or short to power in harness or connectors.

## 12. CHECK APP SENSOR

Refer to [EC-1497, "Component Inspection \(Accelerator Pedal Position Sensor\)"](#).

Is the inspection result normal?

YES >> GO TO 14.

NO >> GO TO 13.

## 13. REPLACE ACCELERATOR PEDAL ASSEMBLY

Replace accelerator pedal assembly.

Refer to [ACC-3, "MODELS WITHOUT DISTANCE CONTROL ASSIST SYSTEM : Removal and Installation"](#) (Without distance control assist system).

Refer to [ACC-4, "MODELS WITH DISTANCE CONTROL ASSIST SYSTEM : Removal and Installation"](#) (With distance control assist system).

>> INSPECTION END

## 14. CHECK INTERMITTENT INCIDENT

Refer to [GI-44, "Intermittent Incident"](#).

>> INSPECTION END

## Component Inspection (Accelerator Pedal Position Sensor)

INFOID:0000000007187763

### 1. CHECK ACCELERATOR PEDAL POSITION SENSOR

1. Turn ignition switch OFF.
2. Reconnect all harness connectors disconnected.
3. Turn ignition switch ON.
4. Check the voltage ECM harness connector terminals under the following conditions.

# P2138 APP SENSOR

< DTC/CIRCUIT DIAGNOSIS >

[VK56VD FOR USA AND CANADA]

| ECM       |                    |          | Condition         | Voltage (V)     |            |
|-----------|--------------------|----------|-------------------|-----------------|------------|
| Connector | +                  | -        |                   |                 |            |
|           | Terminal           | Terminal |                   |                 |            |
| M160      | 136 (APP sensor 1) | 140      | Accelerator pedal | Fully released  | 0.45 - 1.0 |
|           |                    |          |                   | Fully depressed | 4.4 - 4.8  |
|           | 126 (APP sensor 2) | 129      |                   | Fully released  | 0.22 - 0.5 |
|           |                    |          |                   | Fully depressed | 2.1 - 2.5  |

Is the inspection result normal?

YES >> INSPECTION END

NO >> GO TO 2.

## 2. REPLACE ACCELERATOR PEDAL ASSEMBLY

Replace accelerator pedal assembly.

Refer to [ACC-3. "MODELS WITHOUT DISTANCE CONTROL ASSIST SYSTEM : Removal and Installation"](#) (Without distance control assist system).

Refer to [ACC-4. "MODELS WITH DISTANCE CONTROL ASSIST SYSTEM : Removal and Installation"](#) (With distance control assist system).

>> INSPECTION END

# P2539, P2541, P2542 LOW FUEL PRESSURE SENSOR

< DTC/CIRCUIT DIAGNOSIS >

[VK56VD FOR USA AND CANADA]

## P2539, P2541, P2542 LOW FUEL PRESSURE SENSOR

### DTC Logic

INFOID:000000007187764

### DTC DETECTION LOGIC

| DTC No. | Trouble diagnosis name<br>(Trouble diagnosis content)                                    | DTC detecting condition   | Possible cause  |
|---------|--|---|---|
| P2539   | LOW FUEL PRES SEN<br>(Low fuel pressure sensor<br>circuit low input and high in-<br>put) | Signal voltage from the low fuel pressure<br>sensor remains at more than 4.84 V / less<br>than 0.3 V for 5 seconds or more. | <ul style="list-style-type: none"><li>• Harness or connectors<br/>(Low fuel pressure sensor circuit is open<br/>or shorted.)<br/>(Power steering pressure sensor circuit is<br/>open or shorted.)<br/>(EOP sensor circuit is open or shorted.)<br/>(FRP sensor circuit is open or shorted.)</li><li>• Low fuel pressure sensor</li><li>• Power steering pressure sensor</li><li>• EOP sensor</li><li>• FRP sensor</li></ul> |
| P2541   | LOW FUEL PRES SEN<br>(Low fuel pressure sensor<br>circuit low input)                     | Signal voltage from the low fuel pressure<br>sensor remains at less than 0.49 V for 5 sec-<br>onds or more.                 |   |
| P2542   | LOW FUEL PRES SEN<br>(Low fuel pressure sensor<br>circuit high input)                    | Signal voltage from the low fuel pressure<br>sensor remains at more than 4.1 V for 5 sec-<br>onds or more.                  |   |

### DTC CONFIRMATION PROCEDURE

#### 1. PRECONDITIONING

If DTC Confirmation Procedure has been previously conducted, always perform the following procedure before conducting the next test.

1. Turn ignition switch OFF and wait at least 10 seconds.
2. Turn ignition switch ON.
3. Turn ignition switch OFF and wait at least 10 seconds.

#### TESTING CONDITION:

Before performing the following procedure, confirm that battery voltage is 11 V or more at idle.

>> GO TO 2.

#### 2. PERFORM DTC CONFIRMATION PROCEDURE

1. Start engine and let it idle for at least 60 seconds.
2. Check 1st trip DTC.

Is 1st trip DTC detected?

- YES >> Proceed to [EC-1499, "Diagnosis Procedure"](#).  
NO >> INSPECTION END

### Diagnosis Procedure

INFOID:000000007187765

#### NOTE:

Turning the ignition switch ON with low fuel pressure sensor harness connector disconnected causes ECM to detect DTC P2539. Be sure to erase the DTC when the diagnosis procedure.

#### 1. CHECK LOW FUEL PRESSURE SENSOR POWER SUPPLY-I

1. Turn ignition switch OFF.
2. Disconnect low fuel pressure sensor connector.
3. Turn ignition switch ON.
4. Check the voltage between low fuel pressure sensor harness connector terminals.

| Low fuel pressure sensor |   |   | Voltage<br>(Approx.) |
|--------------------------|---|---|----------------------|
| Connector                | + | - |                      |
| F39                      | 3 | 1 | 5 V                  |

Inspection result normal?

- YES >> GO TO 6.

## P2539, P2541, P2542 LOW FUEL PRESSURE SENSOR

< DTC/CIRCUIT DIAGNOSIS >

[VK56VD FOR USA AND CANADA]

NO >> GO TO 2.

### 2. CHECK LOW FUEL PRESSURE SENSOR POWER SUPPLY-II

Check the voltage between low fuel pressure sensor harness connector and the ground.

| +                        |          | -      | Voltage<br>(Approx.) |
|--------------------------|----------|--------|----------------------|
| Low fuel pressure sensor |          |        |                      |
| Connector                | Terminal |        |                      |
| F39                      | 3        | Ground | 5 V                  |

Is inspection result normal?

YES >> GO TO 4.

NO >> GO TO 3.

### 3. CHECK SENSOR POWER SUPPLY CIRCUIT

1. Turn ignition switch OFF.
2. Disconnect ECM harness connector.
3. Check harness connector for short to power and short to ground, between the following terminals.

| ECM       |          | Sensor                         |           |          |
|-----------|----------|--------------------------------|-----------|----------|
| Connector | Terminal | Name                           | Connector | Terminal |
| F110      | 27       | Power steering pressure sensor | F35       | 3        |
|           |          | Low fuel pressure sensor       | F39       | 3        |
|           | 28       | FRP sensor                     | F6        | 1        |
|           |          | Engine oil pressure sensor     | F32       | 3        |

Is inspection result normal?

YES >> Perform the trouble diagnosis for power supply circuit. Refer to [EC-1149, "Diagnosis Procedure"](#).

NO >> Repair or replace error-detected parts.

### 4. CHECK LOW FUEL PRESSURE SENSOR GROUND CIRCUIT

1. Turn ignition switch OFF.
2. Disconnect ECM harness connector.
3. Check the continuity between low fuel pressure sensor harness connector and ECM harness connector.

| +                        |          | -         |          | Continuity |
|--------------------------|----------|-----------|----------|------------|
| Low fuel pressure sensor |          | ECM       |          |            |
| Connector                | Terminal | Connector | Terminal |            |
| F39                      | 1        | F110      | 27       | Existed    |

Is inspection result normal?

YES >> GO TO 5.

NO >> Repair or replace error-detected parts.

### 5. CHECK ECM GROUND CIRCUIT

1. Turn ignition switch OFF.
2. Disconnect ECM harness connector.
3. Check the continuity between ECM harness connector and the ground.

# P2539, P2541, P2542 LOW FUEL PRESSURE SENSOR

< DTC/CIRCUIT DIAGNOSIS >

[VK56VD FOR USA AND CANADA]

| ECM       |          | Ground | Continuity |
|-----------|----------|--------|------------|
| Connector | Terminal |        |            |
| F110      | 10       | Ground | Existed    |
| M160      | 114      |        |            |
|           | 115      |        |            |
|           | 174      |        |            |
|           | 175      |        |            |

Is inspection result normal?

- YES >> Check intermittent incident. Refer to [GI-44, "Intermittent Incident"](#).  
 NO >> Repair or replace error-detected parts.

## 6. CHECK LOW FUEL PRESSURE SENSOR SIGNAL CIRCUIT

- Turn ignition switch OFF.
- Disconnect ECM harness connector.
- Check the continuity between low fuel pressure sensor harness connector and ECM harness connector.

| +                        |          | -         |          | Continuity |
|--------------------------|----------|-----------|----------|------------|
| Low fuel pressure sensor |          | ECM       |          |            |
| Connector                | Terminal | Connector | Terminal |            |
| F39                      | 2        | F110      | 23       | Existed    |

- Also check harness for short to ground and to power.

Is inspection result normal?

- YES >> GO TO 7.  
 NO >> Repair or replace error-detected parts.

## 7. CHECK LOW FUEL PRESSURE SENSOR

Refer to [EC-1501, "Component Inspection"](#).

Is inspection result normal?

- YES >> Check intermittent incident. Refer to [GI-44, "Intermittent Incident"](#).  
 NO >> Replace low fuel pressure sensor. Refer to [EM-193, "Exploded View"](#).

## Component Inspection

INFOID:000000007187766

### 1. CHECK LOW FUEL PRESSURE SENSOR

#### Ⓜ WITH CONSULT

- Turn ignition switch OFF.
- Reconnect harness connector disconnected.
- Start the engine.
- Select "DATA MONITOR" mode with CONSULT.
- Check that the "L/FUEL PRES SEN V" value.

| Data monitor item | Condition                         | Value (Approx.) |
|-------------------|-----------------------------------|-----------------|
| L/FUEL PRES SEN V | Engine speed: idle                | 3,000 –3,300 mV |
|                   | Engine speed: 3,000 rpm (no load) |                 |

#### Ⓧ WITHOUT CONSULT

- Turn ignition switch OFF.
- Reconnect harness connector disconnected.
- Start the engine.
- Check low fuel pressure sensor signal voltage.

# P2539, P2541, P2542 LOW FUEL PRESSURE SENSOR

< DTC/CIRCUIT DIAGNOSIS >

[VK56VD FOR USA AND CANADA]

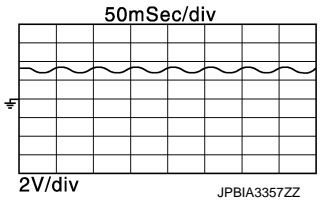
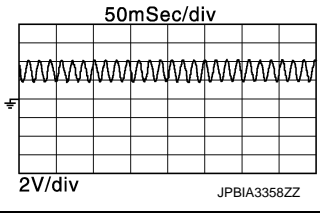
| +                        |          | -      | Condition  | Value<br>(Approx.)   |
|--------------------------|----------|--------|--|--|
| Low fuel pressure sensor |          | Ground |  |  |
| Connector                | Terminal |        |  |  |
| F39                      | 2        | Ground | [Engine is running] <ul style="list-style-type: none"> <li>Warm-up condition</li> <li>Idle speed</li> </ul>              |  |
|                          |          |        | [Engine is running] <ul style="list-style-type: none"> <li>Warm-up condition</li> <li>Engine speed: 2,000 rpm</li> </ul> |  |

Is the inspection result normal?

YES >> INSPECTION END.

NO >> Replace low fuel pressure sensor. Refer to [EM-193, "Exploded View"](#).

# P2A00, P2A03 A/F SENSOR 1

< DTC/CIRCUIT DIAGNOSIS >

[VK56VD FOR USA AND CANADA]

## P2A00, P2A03 A/F SENSOR 1

### DTC Logic

INFOID:000000007784211

#### DTC DETECTION LOGIC

To judge the malfunction, the A/F signal computed by ECM from the A/F sensor 1 signal is monitored so it will not shift to LEAN side or RICH side.

| DTC No. | Trouble diagnosis name<br>(Trouble diagnosis content)                                     | DTC detecting condition   | Possible cause   |
|---------|---|---|--|
| P2A00   | A/F SENSOR1 (B1)<br>(Air fuel ratio (A/F) sensor 1 (bank 1)<br>circuit range/performance) | <ul style="list-style-type: none"><li>The output voltage computed by ECM from the A/F sensor 1 signal shifts to the lean side for a specified period.</li></ul> | <ul style="list-style-type: none"><li>A/F sensor 1</li><li>A/F sensor 1 heater</li><li>Fuel pressure</li><li>Fuel injector</li></ul> |
| P2A03   | A/F SENSOR1 (B2)<br>(Air fuel ratio (A/F) sensor 1 (bank 2)<br>circuit range/performance) | <ul style="list-style-type: none"><li>The A/F signal computed by ECM from the A/F sensor 1 signal shifts to the rich side for a specified period.</li></ul>     | <ul style="list-style-type: none"><li>Intake air leaks</li><li>Heated oxygen sensor 2</li><li>Exhaust gas leak</li></ul>             |

#### DTC CONFIRMATION PROCEDURE

##### 1. PRECONDITIONING

- Turn ignition switch OFF and wait at least 10 seconds.
- Turn ignition switch ON.
- Turn ignition switch OFF and wait at least 10 seconds.

##### TESTING CONDITION:

Before performing the following procedure, confirm that battery voltage is 11 V or more at idle.

>> GO TO 2.

##### 2. PERFORM DTC CONFIRMATION PROCEDURE

- Clear the mixture ratio self-learning value. Refer to [EC-1126, "Work Procedure"](#).
- Turn ignition switch OFF and wait at least 10 seconds.
- Turn ignition switch ON.
- Turn ignition switch OFF and wait at least 10 seconds.
- Start engine and keep the engine speed between 3,500 and 4,000 rpm for 1 minute under no load.
- Let engine idle for 1 minute.
- Keep engine speed between 2,500 and 3,000 rpm for 20 minutes.
- Check 1st trip DTC.

##### Is 1st trip DTC detected?

- YES >> Go to [EC-1503, "Diagnosis Procedure"](#).  
NO >> INSPECTION END

#### Diagnosis Procedure

INFOID:000000007784212

##### 1. RETIGHTEN A/F SENSOR 1 AND HEATED OXYGEN SENSOR 2

Loosen and retighten the A/F sensor 1 and heated oxygen sensor 2. Refer to [EM-223, "Exploded View"](#).

>> GO TO 2.

##### 2. CHECK FOR EXHAUST GAS LEAK

- Start engine and run it at idle.
- Listen for an exhaust gas leak before the three way catalyst 2.

##### Is exhaust gas leak detected?

- YES >> Repair or replace.  
NO >> GO TO 3.

##### 3. CHECK A/F SENSOR 1 CONNECTOR

- Disconnect A/F sensor 1 harness connector.

# P2A00, P2A03 A/F SENSOR 1

[VK56VD FOR USA AND CANADA]

## < DTC/CIRCUIT DIAGNOSIS >

2. Check that water is not inside connectors.

Is the inspection result normal?

- YES >> GO TO 4.  
NO >> Repair or replace harness connector.

### 4. CHECK FOR INTAKE AIR LEAKAGE

1. Reconnect A/F sensor 1 harness connector.
2. Start engine and run it at idle.
3. Listen for an intake air leakage after the mass air flow sensor.

Is intake air leakage detected?

- YES >> Repair or replace malfunctioning part.  
NO >> GO TO 5.

### 5. CLEAR THE MIXTURE RATIO SELF-LEARNING VALUE

1. Clear the mixture ratio self-learning value. Refer to [EC-1126, "Work Procedure"](#).
2. Run engine for at least 10 minutes at idle speed.

Is the 1st trip DTC P0171, P0172, P0174 or P0175 detected? Is it difficult to start engine?

- YES >> Perform trouble diagnosis for DTC P0171, P0174 or P0172, P0175. Refer to [EC-1265, "Diagnosis Procedure"](#) or [EC-1269, "Diagnosis Procedure"](#).  
NO >> GO TO 6.

### 6. CHECK AIR FUEL RATIO SENSOR 1 POWER SUPPLY CIRCUIT

1. Disconnect air fuel ratio (A/F) sensor 1 harness connector.
2. Turn ignition switch ON.
3. Check the voltage between A/F sensor 1 harness connector and ground.

| DTC   | A/F sensor 1 |           |          | Ground | Voltage |
|-------|--------------|-----------|----------|--------|---------|
|       | Bank         | Connector | Terminal |        |         |
| P2A00 | 1            | F23       | 4        | Ground | 3.0 V   |
| P2A03 | 2            | F24       | 4        |        |         |

Is the inspection result normal?

- YES >> GO TO 7.  
NO >> Repair open circuit, short to ground or short to power in harness or connectors.

### 7. CHECK A/F SENSOR 1 INPUT SIGNAL CIRCUIT FOR OPEN AND SHORT

1. Turn ignition switch OFF.
2. Disconnect ECM harness connector.
3. Check the continuity between A/F sensor 1 harness connector and ECM harness connector.

| DTC   | A/F sensor 1 |           |          | ECM       |          | Continuity |
|-------|--------------|-----------|----------|-----------|----------|------------|
|       | Bank         | Connector | Terminal | Connector | Terminal |            |
| P0130 | 1            | F23       | 3        | F111      | 88       | Existed    |
| P0150 | 2            | F24       | 3        |           | 78       |            |

4. Check the continuity between A/F sensor 1 harness connector and ground, or ECM harness connector and ground.

| DTC   | A/F sensor 1 |           |          | ECM       |          | Ground | Continuity  |
|-------|--------------|-----------|----------|-----------|----------|--------|-------------|
|       | Bank         | Connector | Terminal | Connector | Terminal |        |             |
| P0130 | 1            | F23       | 3        | F111      | 88       | Ground | Not existed |
| P0150 | 2            | F24       | 3        |           | 78       |        |             |

5. Also check harness for short to power.

Is the inspection result normal?

- YES >> GO TO 8.



# P2A00, P2A03 A/F SENSOR 1

[VK56VD FOR USA AND CANADA]

< DTC/CIRCUIT DIAGNOSIS >

NO >> Repair open circuit, short to ground or short to power in harness or connectors.

## 8. CHECK A/F SENSOR 1 GROUND CIRCUIT FOR OPEN AND SHORT

1. Turn ignition switch OFF.
2. Disconnect ECM harness connector.
3. Check the continuity between A/F sensor 1 harness connector and ECM harness connector.

| DTC   | A/F sensor 1 |           |          | ECM       |          | Continuity |
|-------|--------------|-----------|----------|-----------|----------|------------|
|       | Bank         | Connector | Terminal | Connector | Terminal |            |
| P0130 | 1            | F23       | 6        | F111      | 94       | Existed    |
| P0150 | 2            | F24       | 6        |           | 74       |            |

4. Also check harness for short to power.

Is the inspection result normal?

YES >> GO TO 9.

NO >> Repair open circuit, short to ground or short to power in harness or connectors.

## 9. CHECK A/F SENSOR 1 HEATER

Refer to [EC-1174, "Component Inspection \(A/F Sensor 1 Heater\)"](#).

Is the inspection result normal?

YES >> GO TO 10.

NO >> GO TO 12.

## 10. CHECK HEATED OXYGEN SENSOR 2

Check heated oxygen sensor 2. Refer to [EC-1247, "Component Inspection \(HO2 sensor 2\)"](#).

Is the inspection result normal?

YES >> GO TO 11.

NO >> Repair or replace malfunctioning part.

## 11. CHECK INTERMITTENT INCIDENT

Perform [GI-44, "Intermittent Incident"](#).

Is the inspection result normal?

YES >> GO TO 12.

NO >> Repair or replace malfunctioning part.

## 12. REPLACE AIR FUEL RATIO (A/F) SENSOR 1

Replace air fuel ratio (A/F) sensor 1. Refer to [EM-223, "Exploded View"](#).

### CAUTION:

- Discard any A/F sensor which has been dropped from a height of more than 0.5 m (19.7 in) onto a hard surface such as a concrete floor; use a new one.
- Before installing new A/F sensor, clean exhaust system threads using Oxygen Sensor Thread Cleaner [commercial service tool (J-43897-18 or J-43897-12)] and approved anti-seize lubricant (commercial service tool).

Will CONSULT be used?

YES >> GO TO 13.

NO >> GO TO 14.

## 13. CONFIRM A/F ADJUSTMENT DATA

 WITH CONSULT

1. Turn ignition switch ON.
2. Select "A/F ADJ-B1" and "A/F ADJ-B2" in "DATA MONITOR" mode with CONSULT.
3. Check that "0.000" is displayed on CONSULT screen.

Is "0.000" displayed?

YES >> INSPECTION END

NO >> GO TO 14.

## 14. CLEAR THE MIXTURE RATIO SELF-LEARNING VALUE

## P2A00, P2A03 A/F SENSOR 1

< DTC/CIRCUIT DIAGNOSIS >

[VK56VD FOR USA AND CANADA]

---

Clear the mixture ratio self-learning value. Refer to [EC-1126. "Work Procedure"](#).

Will CONSULT be used?

YES >> GO TO 15.

NO >> INSPECTION END

### 15.CONFIRM A/F ADJUSTMENT DATA

---

④ WITH CONSULT

1. Turn ignition switch ON.
2. Select "A/F ADJ-B1" and "A/F ADJ-B2" in "DATA MONITOR" mode with CONSULT.
3. Check that "0.000" is displayed on CONSULT screen.

>> INSPECTION END

# ASCD BRAKE SWITCH

< DTC/CIRCUIT DIAGNOSIS >

[VK56VD FOR USA AND CANADA]

## ASCD BRAKE SWITCH

### Component Function Check

INFOID:000000007187769

#### 1. CHECK ASCD BRAKE SWITCH FUNCTION

##### ④ WITH CONSULT

1. Turn ignition switch ON.
2. Select "BRAKE SW1" in "DATA MONITOR" mode with CONSULT.
3. Check "BRAKE SW1" indication under the following conditions.

| Monitor item                     | Condition   |                    | Indication |
|----------------------------------|-------------|--------------------|------------|
| BRAKE SW1<br>(ASCD brake switch) | Brake pedal | Slightly depressed | OFF        |
|                                  |             | Fully released     | ON         |

##### ⊗ WITHOUT CONSULT

1. Turn ignition switch ON.
2. Check the voltage between ECM harness connector terminals as per the following.

| Connector | ECM                               |          | Condition      | Voltage (V)        |           |
|-----------|-----------------------------------|----------|----------------|--------------------|-----------|
|           | +                                 | -        |                |                    |           |
|           | Terminal                          | Terminal |                |                    |           |
| M160      | 147<br>(ASCD brake switch signal) | 175      | Brake pedal    | Slightly depressed | Approx. 0 |
|           |                                   |          | Fully released | Battery voltage    |           |

Is the inspection result normal?

YES >> INSPECTION END

NO >> Proceed to [EC-1507. "Diagnosis Procedure"](#).

### Diagnosis Procedure

INFOID:000000007187770

#### 1. CHECK ASCD BRAKE SWITCH POWER SUPPLY CIRCUIT

1. Turn ignition switch OFF.
2. Disconnect ASCD brake switch harness connector.
3. Turn ignition switch ON.
4. Check the voltage between ASCD brake switch harness connector and ground.

| ASCD brake switch |          | Ground | Voltage         |
|-------------------|----------|--------|-----------------|
| Connector         | Terminal |        |                 |
| E109              | 1        | Ground | Battery voltage |

Is the inspection result normal?

YES >> GO TO 3.

NO >> GO TO 2.

#### 2. DETECT MALFUNCTIONING PART

Check the following.

- 10 A fuse (No. 3)
- Harness for open or short between ASCD brake switch and fuse
- Loose or poor connection for each connector and harness

>> Repair open circuit or short to ground in harness or connectors.

#### 3. CHECK ASCD BRAKE SWITCH INPUT SIGNAL CIRCUIT FOR OPEN AND SHORT

1. Turn ignition switch OFF.
2. Disconnect ECM harness connector.
3. Check the continuity between ASCD brake switch harness connector and ECM harness connector.

# ASCD BRAKE SWITCH

< DTC/CIRCUIT DIAGNOSIS >

[VK56VD FOR USA AND CANADA]

| ASCD brake switch |          | ECM       |          | Continuity |
|-------------------|----------|-----------|----------|------------|
| Connector         | Terminal | Connector | Terminal |            |
| E109              | 2        | M160      | 147      | Existed    |

4. Also check harness for short to ground and short to power.

Is the inspection result normal?

- YES >> GO TO 5.
- NO >> GO TO 4.

## 4.DETECT MALFUNCTIONING PART

Check the following.

- Harness for open or short between ECM and ASCD brake switch
- Loose or poor connection for each connector and harness

>> Repair open circuit, short to ground or short to power in harness or connectors.

## 5.CHECK ASCD BRAKE SWITCH

Refer to [EC-1466, "Component Inspection \(ASCD Brake Switch\)"](#).

Is the inspection result normal?

- YES >> GO TO 6.
- NO >> Replace ASCD brake switch. Refer to [BR-18, "Exploded View"](#).

## 6.CHECK INTERMITTENT INCIDENT

Refer to [GI-44, "Intermittent Incident"](#).

>> INSPECTION END

## Component Inspection (ASCD Brake Switch)

INFOID:000000007187771

### 1.CHECK ASCD BRAKE SWITCH-I

1. Turn ignition switch OFF.
2. Disconnect ASCD brake switch harness connector.
3. Check the continuity between ASCD brake switch terminals under the following conditions.

| Terminals | Condition   |                    | Continuity  |
|-----------|-------------|--------------------|-------------|
| 1 and 2   | Brake pedal | Fully released     | Existed     |
|           |             | Slightly depressed | Not existed |

Is the inspection result normal?

- YES >> INSPECTION END
- NO >> GO TO 2.

### 2.CHECK ASCD BRAKE SWITCH-II

1. Adjust ASCD brake switch installation. Refer to [BR-19, "Inspection and Adjustment"](#).
2. Check the continuity between ASCD brake switch terminals under the following conditions.

| Terminals | Condition   |                    | Continuity  |
|-----------|-------------|--------------------|-------------|
| 1 and 2   | Brake pedal | Fully released     | Existed     |
|           |             | Slightly depressed | Not existed |

Is the inspection result normal?

- YES >> INSPECTION END
- NO >> Replace ASCD brake switch. Refer to [BR-18, "Exploded View"](#).

# ASCD INDICATOR

< DTC/CIRCUIT DIAGNOSIS >

[VK56VD FOR USA AND CANADA]

## ASCD INDICATOR

### Component Function Check

INFOID:000000007187772

#### 1.CHECK ASCD INDICATOR FUNCTION

Check ASCD indicator under the following conditions.

| ASCD INDICATOR | CONDITION  |  | SPECIFICATION |
|----------------|--|--|---------------|
| CRUISE LAMP    | <ul style="list-style-type: none"><li>Ignition switch: ON</li></ul>  | <ul style="list-style-type: none"><li>MAIN switch: Pressed at the 1st time → at the 2nd time</li></ul> | ON → OFF      |
| SET LAMP       | <ul style="list-style-type: none"><li>MAIN switch: ON</li><li>When vehicle speed is between 40 km/h (25 MPH) and 144 km/h (89 MPH)</li></ul> | <ul style="list-style-type: none"><li>ASCD: Operating</li></ul>  | ON            |
|                |  | <ul style="list-style-type: none"><li>ASCD: Not operating</li></ul>                                    | OFF           |

Is the inspection result normal?

YES >> INSPECTION END

NO >> Proceed to [EC-1509, "Diagnosis Procedure"](#).

#### Diagnosis Procedure

INFOID:000000007187773

#### 1.CHECK DTC

Check that DTC UXXXX is not displayed.

Is the inspection result normal?

YES >> GO TO 2.

NO >> Perform trouble diagnosis for DTC UXXXX.

#### 2.CHECK DTC WITH COMBINATION METER

Refer to [MWI-31, "CONSULT Function"](#).

Is the inspection result normal?

YES >> GO TO 3.

NO >> Repair or replace malfunctioning part.

#### 3.CHECK INTERMITTENT INCIDENT

Refer to [GI-44, "Intermittent Incident"](#).

Is the inspection result normal?

YES >> Replace combination meter. Refer to [MWI-79, "Removal and Installation"](#).

NO >> Repair or replace malfunctioning part.

## COOLING FAN

### Description

INFOID:000000007187774

#### COOLING FAN CONTROL MODULE

Cooling fan control module receives ON/OFF pulse duty signal from IPDM E/R. Corresponding to this ON/OFF pulse duty signal, cooling fan control module sends cooling fan motor operating voltage to cooling fan motor. The revolution speed of cooling fan motor is controlled by duty cycle of the voltage.

#### COOLING FAN MOTOR

Cooling fan motor receives cooling fan motor operating voltage from cooling fan control module. The revolution speed of cooling fan motor is controlled by duty cycle of the voltage.

### Component Function Check

INFOID:000000007187775

#### 1. CHECK COOLING FAN FUNCTION

##### WITH CONSULT

1. Turn ignition switch ON.
2. Perform "FAN DUTY CONTROL" in "ACTIVE TEST" mode with CONSULT.
3. Check that cooling fan speed varies according to the percentage.

##### WITHOUT CONSULT

1. Perform IPDM E/R auto active test and check cooling fan motors operation, refer to [PCS-12, "Diagnosis Description"](#).
2. Check that cooling fan operates.

Is the inspection result normal?

- YES >> INSPECTION END  
 NO >> Proceed to [EC-1510, "Diagnosis Procedure"](#).

### Diagnosis Procedure

INFOID:000000007187776

#### 1. CHECK COOLING FAN CONTROL MODULE POWER SUPPLY CIRCUIT-I

1. Turn ignition switch OFF.
2. Disconnect cooling fan control module harness connectors E37, E38.
3. Turn ignition switch ON.
4. Check the voltage between cooling fan control module harness connector and ground.

| Cooling fan control module            |          | Ground | Voltage         |
|---------------------------------------|----------|--------|-----------------|
| Connector                             | Terminal |        |                 |
| E37<br>(Cooling fan control module 1) | 3        | Ground | Battery voltage |
| E39<br>(Cooling fan control module 2) | 3        |        |                 |

Is the inspection result normal?

- YES >> GO TO 2.  
 NO >> GO TO 7.

#### 2. CHECK COOLING FAN CONTROL MODULE GROUND CIRCUIT

1. Turn ignition switch OFF.
2. Check the continuity between cooling fan control module harness connector and ground.

# COOLING FAN

< DTC/CIRCUIT DIAGNOSIS >

[VK56VD FOR USA AND CANADA]

| Cooling fan control module            |          | Ground | Continuity |
|---------------------------------------|----------|--------|------------|
| Connector                             | Terminal |        |            |
| E37<br>(Cooling fan control module 1) | 1        | Ground | Existed    |
| E39<br>(Cooling fan control module 2) | 1        |        |            |

3. Also check harness for short to power.

Is the inspection result normal?

YES >> GO TO 3.

NO >> Repair open circuit or short to power in harness or connectors.

### 3.CHECK IPDM E/R GROUND CIRCUIT

1. Disconnect IPDM E/R harness connectors E5, E6.
2. Check the continuity between IPDM E/R harness connector and ground.

| IPDM E/R  |          | Ground | Continuity |
|-----------|----------|--------|------------|
| Connector | Terminal |        |            |
| E5        | 11       | Ground | Existed    |
| E6        | 41       |        |            |

3. Also check harness for short to power.

Is the inspection result normal?

YES >> GO TO 4.

NO >> Repair open circuit or short to power in harness or connectors.

### 4.CHECK COOLING FAN CONTROL SIGNAL CIRCUIT

1. Disconnect IPDM E/R harness connector E9.
2. Check the continuity between IPDM E/R harness connector and cooling fan control module harness connector.

| IPDM E/R  |          | Cooling fan control module            |          | Continuity |
|-----------|----------|---------------------------------------|----------|------------|
| Connector | Terminal | Connector                             | Terminal |            |
| E9        | 97       | E37<br>(Cooling fan control module 1) | 2        | Existed    |
|           |          | E39<br>(Cooling fan control module 2) | 2        | Existed    |

3. Also check harness for short to ground and short to power.

Is the inspection result normal?

YES >> GO TO 5.

NO >> Repair open circuit, short to ground or short to power in harness or connectors.

### 5.CHECK COOLING FAN CONTROL MODULE OUTPUT SIGNAL CIRCUIT

1. Reconnect all harness connectors disconnected.
2. Disconnect cooling fan control module harness connectors E301, E303.
3. Turn ignition switch ON.
4. Check the voltage between cooling fan control module terminals and ground.

| Cooling fan control module            |          | Ground | Voltage         |
|---------------------------------------|----------|--------|-----------------|
| Connector                             | Terminal |        |                 |
| E37<br>(Cooling fan control module 1) | 4        | Ground | Battery voltage |
| E39<br>(Cooling fan control module 2) | 6        |        |                 |

A  
EC  
C  
D  
E  
F  
G  
H  
I  
J  
K  
L  
M  
N  
O  
P

# COOLING FAN

[VK56VD FOR USA AND CANADA]

< DTC/CIRCUIT DIAGNOSIS >

Is the inspection result normal?

YES >> GO TO 6.

NO >> Replace malfunctioning cooling fan control module. Refer to [CO-44. "Exploded View"](#).

## 6.CHECK COOLING FAN MOTORS -1 AND -2

Refer to [EC-1513. "Component Inspection \(Cooling Fan Motor\)"](#).

Is the inspection result normal?

YES >> GO TO 11.

NO >> Replace malfunctioning cooling fan motor. Refer to [CO-44. "Exploded View"](#).

## 7.CHECK COOLING FAN CONTROL MODULE POWER SUPPLY CIRCUIT-II

1. Turn ignition switch OFF.
2. Disconnect cooling fan relay-1 and cooling fan relay-2.
3. Check the voltage between cooling fan relay harness connector and ground.

| Cooling fan relay            |          | Ground | Voltage         |
|------------------------------|----------|--------|-----------------|
| Connector                    | Terminal |        |                 |
| E17<br>(Cooling fan relay-1) | 3        | Ground | Battery voltage |
| E19<br>(Cooling fan relay-2) | 3        |        |                 |

4. Turn ignition switch ON.
5. Check the voltage between cooling fan relay harness connector and ground.

| Cooling fan relay            |          | Ground | Voltage         |
|------------------------------|----------|--------|-----------------|
| Connector                    | Terminal |        |                 |
| E17<br>(Cooling fan relay-1) | 2        | Ground | Battery voltage |

Is the inspection result normal?

YES >> GO TO 9.

NO >> GO TO 8.

## 8.DETECT MALFUNCTIONING PART

Check the following.

- 10 A fuse (No. 42)
- 50 A fusible link (letter O)
- 50 A fusible link (letter R)
- IPDM E/R harness connector E7
- Harness for open or short between cooling fan relay and fuse
- Harness for open or short between cooling fan relay and battery

>> Repair open circuit, short to ground or short to power in harness or connectors.

## 9.CHECK COOLING FAN CONTROL MODULE POWER SUPPLY CIRCUIT-III

1. Turn ignition switch OFF.
2. Disconnect IPDM E/R harness connector E6.
3. Check the continuity between cooling fan relay harness connector and IPDM E/R harness connector.

| Cooling fan relay            |          | IPDM E/R  |          | Continuity |
|------------------------------|----------|-----------|----------|------------|
| Connector                    | Terminal | Connector | Terminal |            |
| E17<br>(Cooling fan relay-1) | 1        | E6        | 42       | Existed    |

4. Check the continuity between cooling fan relay harness connector and cooling fan control module harness connector.



# COOLING FAN

< DTC/CIRCUIT DIAGNOSIS >

[VK56VD FOR USA AND CANADA]

| Cooling fan relay            |          | Cooling fan control module            |          | Continuity |
|------------------------------|----------|---------------------------------------|----------|------------|
| Connector                    | Terminal | Connector                             | Terminal |            |
| E17<br>(Cooling fan relay-1) | 5        | E37<br>(Cooling fan control module-1) | 3        | Existed    |
| E19<br>(Cooling fan relay-2) | 5        | E39<br>(Cooling fan control module-2) | 3        | Existed    |

5. Check the continuity between cooling fan relay-1 harness connector and cooling fan relay-2 harness connector.

| Cooling fan relay            |          |                              |          | Continuity |
|------------------------------|----------|------------------------------|----------|------------|
| Connector                    | Terminal | Connector                    | Terminal |            |
| E17<br>(Cooling fan relay-1) | 5        | E19<br>(Cooling fan relay-2) | 2        | Existed    |

6. Check the continuity between cooling fan relay-2 harness connector and ground.

| Cooling fan relay            |          | Ground | Continuity |
|------------------------------|----------|--------|------------|
| Connector                    | Terminal |        |            |
| E17<br>(Cooling fan relay-1) | 1        | Ground | Existed    |

7. Also check harness for short to ground and short to power.

Is the inspection result normal?

YES >> GO TO 10.

NO >> Repair open circuit, short to ground or short to power in harness or connectors.

## 10.CHECK COOLING FAN RELAYS -1 AND -2

Refer to [EC-1514. "Component Inspection \(Cooling Fan Relay\)".](#)

Is the inspection result normal?

YES >> GO TO 11.

NO >> Replace malfunctioning cooling fan relay.

## 11.CHECK INTERMITTENT INCIDENT

Perform [GI-44. "Intermittent Incident".](#)

Is the inspection result normal?

YES >> Replace IPDM E/R. Refer to [PCS-33. "Removal and Installation".](#)

NO >> Repair or replace harness connectors.

## Component Inspection (Cooling Fan Motor)

INFOID:000000007187777

### 1.CHECK COOLING FAN MOTOR

1. Turn ignition switch OFF.
2. Disconnect cooling fan control module harness connectors E301, E303.
3. Supply cooling fan control module harness connector terminals with battery voltage as per the following, and check operation.

| Cooling fan control module |           |          |     | Operation             |
|----------------------------|-----------|----------|-----|-----------------------|
| Motor                      | Connector | Terminal |     |                       |
|                            |           | (+)      | (-) |                       |
| 1                          | E301      | 4        | 5   | Cooling fan operates. |
| 2                          | E303      | 6        | 7   |                       |

Is the inspection result normal?

YES >> INSPECTION END

# COOLING FAN

[VK56VD FOR USA AND CANADA]

< DTC/CIRCUIT DIAGNOSIS >

NO >> Replace malfunctioning cooling fan motor. Refer to [CO-44. "Exploded View"](#).

## Component Inspection (Cooling Fan Relay)

INFOID:000000007187778

### 1. CHECK COOLING FAN RELAY

1. Turn ignition switch OFF.
2. Remove cooling fan relay.
3. Check the continuity between cooling fan relay terminals under the following conditions.

| Terminals | Conditions   | Continuity  |
|-----------|--|-------------|
| 3 and 5   | 12 V direct current supply between terminals 1 and 2 | Existed     |
|           | No current supply                                    | Not existed |

Is the inspection result normal?

- YES >> INSPECTION END  
NO >> Replace cooling fan relay.

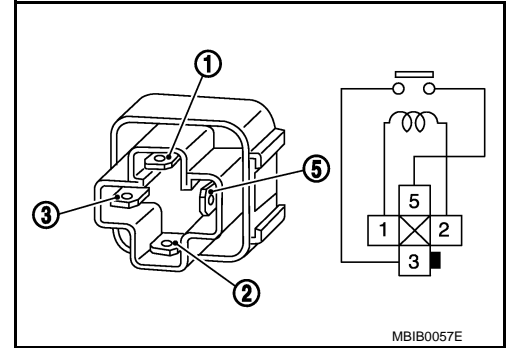

# ELECTRICAL LOAD SIGNAL

< DTC/CIRCUIT DIAGNOSIS >

[VK56VD FOR USA AND CANADA]

## ELECTRICAL LOAD SIGNAL

### Description

INFOID:000000007187779

The electrical load signal (Rear window defogger switch signal, headlamp switch signal, blower fan switch signal, etc.) is transferred via the CAN communication line.

### Component Function Check

INFOID:000000007187780

#### 1.CHECK REAR WINDOW DEFOGGER SWITCH FUNCTION

1. Turn ignition switch ON.
2. Select "DATA MONITOR" mode with CONSULT.
3. Select "LOAD SIGNAL" and check indication under the following conditions.

| Monitor item | Condition                   | Indication |     |
|--------------|-----------------------------|------------|-----|
| LOAD SIGNAL  | Rear window defogger switch | ON         | ON  |
|              |                             | OFF        | OFF |

Is the inspection result normal?

YES >> GO TO 2.

NO >> Proceed to [EC-1515, "Diagnosis Procedure"](#).

#### 2.CHECK LIGHTING SWITCH FUNCTION

Check "LOAD SIGNAL" indication under the following conditions.

| Monitor item | Condition       | Indication         |     |
|--------------|-----------------|--------------------|-----|
| LOAD SIGNAL  | Lighting switch | ON at 2nd position | ON  |
|              |                 | OFF                | OFF |

Is the inspection result normal?

YES >> GO TO 3.

NO >> Proceed to [EC-1515, "Diagnosis Procedure"](#).

#### 3.CHECK BLOWER FAN CONTROL SWITCH FUNCTION

Select "HEATER FAN SW" and check indication under the following conditions.

| Monitor item  | Condition                 | Indication |     |
|---------------|---------------------------|------------|-----|
| HEATER FAN SW | Blower fan control switch | ON         | ON  |
|               |                           | OFF        | OFF |

Is the inspection result normal?

YES >> INSPECTION END

NO >> Proceed to [EC-1515, "Diagnosis Procedure"](#).

### Diagnosis Procedure

INFOID:000000007187781

#### 1.INSPECTION START

Confirm the malfunctioning circuit (rear window defogger, headlamp or blower fan). Refer to [EC-1515, "Component Function Check"](#).

Which circuit is related to the incident?

Rear window defogger>>GO TO 2.

Headlamp>>GO TO 3.

Heater fan>>GO TO 4.

#### 2.CHECK REAR WINDOW DEFOGGER SYSTEM

Refer to [DEF-11, "Work Flow"](#).

## ELECTRICAL LOAD SIGNAL

< DTC/CIRCUIT DIAGNOSIS >

[VK56VD FOR USA AND CANADA]

---

>> INSPECTION END

### 3.CHECK HEADLAMP SYSTEM

---

Refer to [EXL-49, "Work Flow"](#).

>> INSPECTION END

### 4.CHECK BLOWER FAN CONTROL SYSTEM

---

Refer to [HAC-68, "Work Flow"](#).

>> INSPECTION END

## FUEL INJECTOR

### Component Function Check

INFOID:000000007187782

#### 1.INSPECTION START

Turn ignition switch to START.

Are any cylinders ignited?

- YES >> GO TO 2.
- NO >> Proceed to [EC-1517, "Diagnosis Procedure"](#).

#### 2.CHECK FUEL INJECTOR FUNCTION

##### Ⓜ WITH CONSULT

1. Start engine.
2. Perform "POWER BALANCE" in "ACTIVE TEST" mode with CONSULT.
3. Check that each circuit produces a momentary engine speed drop.

##### ⓧ WITHOUT CONSULT

1. Start engine.
2. Listen to each fuel injector operating sound.

**Clicking sound should be heard.**

Is the inspection result normal?

- YES >> INSPECTION END
- NO >> Proceed to [EC-1517, "Diagnosis Procedure"](#).

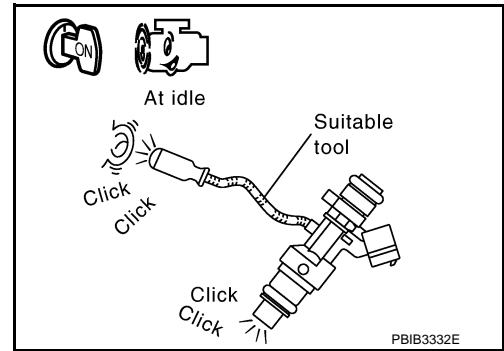

### Diagnosis Procedure

INFOID:000000007187783

#### 1.CHECK FUEL INJECTOR POWER SUPPLY

1. Turn ignition switch ON.
2. Check the voltage between ECM harness connector and ground.

| +         |          | -      | Voltage         |  |  |
|-----------|----------|--------|-----------------|--|--|
| ECM       |          |        |                 |  |  |
| Connector | Terminal | Ground | Battery voltage |  |  |
| F110      | 46       |        |                 |  |  |
|           | 51       |        |                 |  |  |
| M160      | 111      |        |                 |  |  |
|           | 112      |        |                 |  |  |

Is the inspection result normal?

- YES >> GO TO 2.
- NO >> Perform the trouble diagnosis for power supply circuit. Refer to [EC-1149, "Diagnosis Procedure"](#).

#### 2.CHECK FUEL INJECTOR CIRCUIT

1. Turn ignition switch OFF.
2. Disconnect fuel injector harness connector and ECM harness connector.
3. Check the continuity between fuel injector harness connector and ECM harness connector.

# FUEL INJECTOR

< DTC/CIRCUIT DIAGNOSIS >

[VK56VD FOR USA AND CANADA]

| Cylinder | +             |          | -         |          | Continuity |
|----------|---------------|----------|-----------|----------|------------|
|          | Fuel injector |          | ECM       |          |            |
|          | Connector     | Terminal | Connector | Terminal |            |
| 1        | F131          | 1        | F111      | 101      | Existed    |
|          |               | 2        |           | 108      |            |
| 2        | F132          | 1        | F110      | 7        |            |
|          |               | 2        |           | 4        |            |
| 3        | F133          | 1        | F110      | 6        |            |
|          |               | 2        |           | 3        |            |
| 4        | F134          | 1        | F111      | 107      |            |
|          |               | 2        |           | 104      |            |
| 5        | F135          | 1        | F110      | 2        |            |
|          |               | 2        |           | 9        |            |
| 6        | F136          | 1        | F111      | 102      |            |
|          |               | 2        |           | 109      |            |
| 7        | F137          | 1        | F111      | 106      |            |
|          |               | 2        |           | 103      |            |
| 8        | F138          | 1        | F110      | 1        |            |
|          |               | 2        |           | 8        |            |

4. Also check harness for short to ground and to power.

Is the inspection result normal?

YES >> GO TO 3.

NO >> Repair or replace error-detected parts.

## 3. CHECK ECM GROUND CIRCUIT

Check the continuity between ECM harness connector and ground.

| +         |          | -      | Continuity |
|-----------|----------|--------|------------|
| ECM       |          |        |            |
| Connector | Terminal |        |            |
| F110      | 5        | Ground | Existed    |
| M160      | 114      |        |            |
|           | 115      |        |            |

Is inspection result normal?

YES >> GO TO 4.

NO >> Repair or replace error-detected parts.

## 4. CHECK FUEL INJECTOR

Refer to [EC-1518, "Component Inspection"](#).

Is the inspection result normal?

YES >> Check intermittent incident. Refer to [GI-44, "Intermittent Incident"](#).

NO >> Replace malfunctioning fuel injector. Refer to [EM-197, "Exploded View"](#).

## Component Inspection

INFOID:000000007187784

### 1. CHECK FUEL INJECTOR

1. Turn ignition switch OFF.
2. Disconnect fuel injector harness connector.
3. Check the resistance between fuel injector terminals as per the following.

# FUEL INJECTOR

< DTC/CIRCUIT DIAGNOSIS >

[VK56VD FOR USA AND CANADA]

| +        |   | -           |                        | Condition     | Resistance |
|----------|---|-------------|------------------------|---------------|------------|
| Injector |   |             |                        |               |            |
| Terminal |   |             |                        |               |            |
| 1        | 2 | Temperature | 10 - 60°C (50 - 140°F) | 1.44 - 1.73 Ω |            |

Is the inspection result normal?

YES >> INSPECTION END

NO >> Replace malfunctioning fuel injector. Refer to [EM-197, "Exploded View"](#).

A

EC

C

D

E

F

G

H

I

J

K

L

M

N

O

P

# HIGH PRESSURE FUEL PUMP

< DTC/CIRCUIT DIAGNOSIS >

[VK56VD FOR USA AND CANADA]

## HIGH PRESSURE FUEL PUMP

### Component Function Check

INFOID:000000007187785

#### 1. CHECK HIGH PRESSURE FUEL PUMP FUNCTION



##### ④ WITH CONSULT

1. Start engine.
2. Check "FUEL PRES SEN V" in "DATA MONITOR" mode with CONSULT.

| Monitor Item    | Condition   | Values/Status  |
|-----------------|---|----------------|
| FUEL PRES SEN V | Engine speed: Idle  | 820 – 1,220 mV |
|                 | Engine speed: Revving engine from idle to 4,000 rpm quickly | 820 – 3,060 mV |

##### ⊗ WITHOUT CONSULT

1. Start engine.
2. Check the voltage between ECM harness connector and ground.

| ECM       |          |           |          | Condition  | Voltage   |
|-----------|----------|-----------|----------|--|---|
| +         |          | -         |          |  |   |
| Connector | Terminal | Connector | Terminal |  |   |
| F111      | 105      | M160      | 175      | [Engine is running] <ul style="list-style-type: none"> <li>• Warm-up condition</li> <li>• Idle speed</li> </ul> <b>NOTE:</b><br>The pulse cycle changes depending on rpm at idle | BATTERY VOLTAGE<br>(11 - 14 V)★<br>20mSec/div<br><br>10V/div JPBIA3340ZZ  |
|           |          |           |          | [Engine is running] <ul style="list-style-type: none"> <li>• Warm-up condition</li> <li>• Engine speed: 2,000 rpm</li> </ul>   | BATTERY VOLTAGE<br>(11 - 14 V)★<br>20mSec/div<br><br>10V/div JPBIA3341ZZ |

Is the inspection result normal?

- YES >> INSPECTION END  
 NO >> Proceed to [EC-1520. "Diagnosis Procedure"](#).

### Diagnosis Procedure

INFOID:000000007187786

#### 1. CHECK HIGH PRESSURE FUEL PUMP CIRCUIT

1. Turn ignition switch OFF.
2. Disconnect ECM harness connector and high pressure fuel pump harness connector.
3. Check the continuity between ECM harness connector and high pressure fuel pump harness connector.

| +         |          | -                       |          | Continuity |
|-----------|----------|-------------------------|----------|------------|
| ECM       |          | High pressure fuel pump |          |            |
| Connector | Terminal | Connector               | Terminal |            |
| F111      | 110      | F4                      | 2        | Existed    |
|           | 105      |                         | 1        | Existed    |



# HIGH PRESSURE FUEL PUMP

[VK56VD FOR USA AND CANADA]

## < DTC/CIRCUIT DIAGNOSIS >

4. Also check harness for short to ground and to power.

Is inspection result normal?

YES >> GO TO 2.

NO >> Repair or replace error-detected parts.

## 2.CHECK HIGH PRESSURE FUEL PUMP

Refer to [EC-1521, "Component Inspection"](#).

Is inspection result normal?

YES >> GO TO 3.

NO >> Replace high pressure fuel pump. Refer to [EM-193, "Removal and Installation"](#).

## 3.CHECK HIGH PRESSURE FUEL PUMP INSTALLATION CONDITION

1. Turn ignition switch OFF.

2. Check that the high pressure fuel pump is installed with no backlash and looseness.

Is the inspection result normal?

YES >> GO TO 4.

NO >> Repair or replace error-detected parts.

## 4.CHECK CAMSHAFT

1. Remove camshaft. Refer to [EM-246, "Exploded View"](#).

2. Check camshaft. Refer to [EM-246, "Exploded View"](#).

Is inspection result normal?

YES >> INSPECTION END

NO >> Replace camshaft. Refer to [EM-246, "Exploded View"](#).

## Component Inspection

INFOID:000000007187787

## 1.CHECK HIGH PRESSURE FUEL PUMP SOLENOID

1. Turn ignition switch OFF.

2. Disconnect high pressure fuel pump harness connector.

3. Check the resistance between high pressure fuel pump connector terminals as per the following.

| +      -                |   | Condition   |                       | Resistance |
|-------------------------|---|-------------|-----------------------|------------|
| High pressure fuel pump |   |             |                       |            |
| Terminal                |   |             |                       |            |
| 1                       | 2 | Temperature | 20 – 30°C (68 – 86°F) | 9 – 11 Ω   |

Is the inspection result normal?

YES >> INSPECTION END

NO >> Replace high pressure fuel pump. Refer to [EM-193, "Exploded View"](#).

## ICC BRAKE SWITCH

### Component Function Check

INFOID:000000007187788

#### 1. CHECK ICC BRAKE SWITCH FUNCTION

##### WITH CONSULT

1. Turn ignition switch ON.
2. Select "BRAKE SW1" in "DATA MONITOR" mode with CONSULT.
3. Check "BRAKE SW1" indication under the following conditions.

| Monitor item                    | Condition   | Indication         |     |
|---------------------------------|-------------|--------------------|-----|
| BRAKE SW1<br>(ICC brake switch) | Brake pedal | Slightly depressed | OFF |
|                                 |             | Fully released     | ON  |

##### WITHOUT CONSULT

1. Turn ignition switch ON.
2. Check the voltage between ECM harness connector terminals as per the following.

| ECM       |                                  |          | Condition   | Voltage            |                 |
|-----------|----------------------------------|----------|-------------|--------------------|-----------------|
| Connector | +                                | -        |             |                    |                 |
|           |                                  | Terminal | Terminal    |                    |                 |
| M160      | 147<br>(ICC brake switch signal) | 175      | Brake pedal | Slightly depressed | Approx. 0 V     |
|           |                                  |          |             | Fully released     | Battery voltage |

Is the inspection result normal?

- YES >> INSPECTION END  
 NO >> Proceed to [EC-1522. "Diagnosis Procedure"](#).

### Diagnosis Procedure

INFOID:000000007187789

#### 1. CHECK ICC BRAKE SWITCH POWER SUPPLY CIRCUIT

1. Turn ignition switch OFF.
2. Disconnect ICC brake switch harness connector.
3. Turn ignition switch ON.
4. Check the voltage between ICC brake switch harness connector and ground.

| ICC brake switch |          | Ground | Voltage         |
|------------------|----------|--------|-----------------|
| Connector        | Terminal |        |                 |
| E114             | 1        | Ground | Battery voltage |

Is the inspection result normal?

- YES >> GO TO 3.  
 NO >> GO TO 2.

#### 2. DETECT MALFUNCTIONING PART

Check the following.

- 10 A fuse (No. 3)
- Harness for open or short between ICC brake switch and fuse
- Loose or poor connection for each connector and harness

>> Repair open circuit or short to ground in harness or connectors.

#### 3. CHECK ICC BRAKE SWITCH INPUT SIGNAL CIRCUIT FOR OPEN AND SHORT

1. Turn ignition switch OFF.
2. Disconnect ECM harness connector.

# ICC BRAKE SWITCH

[VK56VD FOR USA AND CANADA]

## < DTC/CIRCUIT DIAGNOSIS >

3. Check the continuity between ICC brake switch harness connector and ECM harness connector.

| ICC brake switch |          | ECM       |          | Continuity |
|------------------|----------|-----------|----------|------------|
| Connector        | Terminal | Connector | Terminal |            |
| E114             | 2        | M160      | 147      | Existed    |

4. Also check harness for short to ground and short to power.

Is the inspection result normal?

YES >> GO TO 5.

NO >> GO TO 4.

## 4.DETECT MALFUNCTIONING PART

Check the following.

- Harness for open or short between ECM and ICC brake switch
- Loose or poor connection for each connector and harness

>> Repair open circuit, short to ground or short to power in harness or connectors.

## 5.CHECK ICC BRAKE SWITCH

Refer to [EC-1523, "Component Inspection \(ICC Brake Switch\)"](#).

Is the inspection result normal?

YES >> GO TO 6.

NO >> Replace ICC brake switch. Refer to [BR-18, "Exploded View"](#).

## 6.CHECK INTERMITTENT INCIDENT

Refer to [GI-44, "Intermittent Incident"](#).

>> INSPECTION END

## Component Inspection (ICC Brake Switch)

INFOID:000000007187790

### 1.CHECK ICC BRAKE SWITCH-I

1. Turn ignition switch OFF.
2. Disconnect ICC brake switch harness connector.
3. Check the continuity between ICC brake switch terminals under the following conditions.

| Terminals | Condition   |                    | Continuity  |
|-----------|-------------|--------------------|-------------|
| 1 and 2   | Brake pedal | Fully released     | Existed     |
|           |             | Slightly depressed | Not existed |

Is the inspection result normal?

YES >> INSPECTION END

NO >> GO TO 2.

### 2.CHECK ICC BRAKE SWITCH-II

1. Adjust ICC brake switch installation. Refer to [BR-18, "Removal and Installation"](#).
2. Check the continuity between ICC brake switch terminals under the following conditions.

| Terminals | Condition   |                    | Continuity  |
|-----------|-------------|--------------------|-------------|
| 1 and 2   | Brake pedal | Fully released     | Existed     |
|           |             | Slightly depressed | Not existed |

Is the inspection result normal?

YES >> INSPECTION END

NO >> Replace ICC brake switch. Refer to [BR-18, "Exploded View"](#).

# ICC BRAKE SWITCH

< DTC/CIRCUIT DIAGNOSIS >

[VK56VD FOR USA AND CANADA]

## Component Inspection (ICC Brake Hold Relay)

INFOID:000000007187791

### 1. CHECK ICC BRAKE HOLD RELAY

1. Turn ignition switch OFF.
2. Remove ICC brake hold relay.
3. Check the continuity between ICC brake hold relay terminals under the following conditions.

| Terminals | Condition   | Continuity  |
|-----------|---|-------------|
| 3 and 5   | 12V direct current supply between terminals 1 and 2 | Existed     |
|           | No current supply                                   | Not existed |

Is the inspection result normal?

- YES >> INSPECTION END  
NO >> Replace ICC brake hold relay

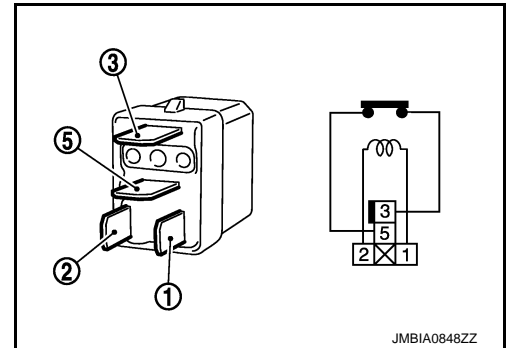

## IGNITION SIGNAL

### Component Function Check

INFOID:000000007187792

#### 1.INSPECTION START

Turn ignition switch OFF, and restart engine.

Does the engine start?

- YES-1 >> With CONSULT: GO TO 2.
- YES-2 >> Without CONSULT: GO TO 3.
- NO >> Proceed to [EC-1525, "Diagnosis Procedure"](#).

#### 2.CHECK IGNITION SIGNAL FUNCTION

WITH CONSULT

1. Perform "POWER BALANCE" in "ACTIVE TEST" mode with CONSULT.
2. Check that each circuit produces a momentary engine speed drop.

Is the inspection result normal?

- YES >> INSPECTION END
- NO >> Proceed to [EC-1525, "Diagnosis Procedure"](#).

#### 3.CHECK IGNITION SIGNAL FUNCTION

WITHOUT CONSULT

1. Let engine idle.
2. Read the voltage signal between ECM harness connector terminals under the following conditions with an oscilloscope.

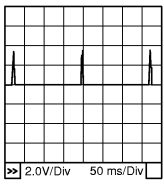
| Cylinder | ECM       |          |           |          | Voltage signal   |
|----------|-----------|----------|-----------|----------|--|
|          | +         |          | -         |          |  |
|          | Connector | Terminal | Connector | Terminal |  |
| 1        | F110      | 12       | M160      | 175      |  |
| 2        |           |          |           |          |  |
| 3        |           |          |           |          |  |
| 4        |           |          |           |          |  |
| 5        |           |          |           |          |  |
| 6        |           |          |           |          |  |
| 7        |           |          |           |          |  |
| 8        |           |          |           |          |  |

**NOTE:**

The pulse cycle changes depending on rpm at idle.

Is the inspection result normal?

- YES >> INSPECTION END
- NO >> Proceed to [EC-1525, "Diagnosis Procedure"](#).

### Diagnosis Procedure

INFOID:000000007187793

#### 1.CHECK IGNITION COIL POWER SUPPLY CIRCUIT-I

1. Turn ignition switch OFF, wait at least 10 seconds and then turn it ON.
2. Check the voltage between ECM harness connector terminals under the following conditions.

# IGNITION SIGNAL

< DTC/CIRCUIT DIAGNOSIS >

[VK56VD FOR USA AND CANADA]

| ECM       |          |          | Voltage         |
|-----------|----------|----------|-----------------|
| Connector | +        | -        |                 |
|           | Terminal | Terminal |                 |
| M160      | 171      | 175      | Battery voltage |
|           | 172      |          |                 |

Is the inspection result normal?

YES >> GO TO 2.

NO >> Proceed to [EC-1149, "Diagnosis Procedure"](#).

## 2.CHECK IGNITION COIL POWER SUPPLY CIRCUIT-II

1. Turn ignition switch OFF.
2. Disconnect condenser harness connector.
3. Turn ignition switch ON.
4. Check the voltage between condenser harness connector and ground.

| Condenser |          | Ground | Voltage         |
|-----------|----------|--------|-----------------|
| Connector | Terminal |        |                 |
| F41       | 1        | Ground | Battery voltage |

Is the inspection result normal?

YES >> GO TO 5.

NO >> GO TO 3.

## 3.CHECK IGNITION COIL POWER SUPPLY CIRCUIT-III

1. Turn ignition switch OFF.
2. Disconnect IPDM E/R harness connector E7.
3. Check the continuity between IPDM E/R harness connector and condenser harness connector.

| IPDM E/R  |          | Condenser |          | Continuity |
|-----------|----------|-----------|----------|------------|
| Connector | Terminal | Connector | Terminal |            |
| E5        | 5        | F41       | 1        | Existed    |

4. Also check harness for short to ground and short to power.

Is the inspection result normal?

YES >> Proceed to [EC-1149, "Diagnosis Procedure"](#).

NO >> GO TO 4.

## 4.DETECT MALFUNCTIONING PART

Check the following.

- Harness for open or short between IPDM E/R and condenser
- Loose or poor connection for each connector and harness

>> Repair open circuit, short to ground or short to power in harness or connectors.

## 5.CHECK CONDENSER GROUND CIRCUIT FOR OPEN AND SHORT

1. Turn ignition switch OFF.
2. Check the continuity between condenser harness connector and ground.

| Condenser |          | Ground | Continuity |
|-----------|----------|--------|------------|
| Connector | Terminal |        |            |
| F41       | 2        | Ground | Existed    |

3. Also check harness for short to power.

Is the inspection result normal?

# IGNITION SIGNAL

[VK56VD FOR USA AND CANADA]

## < DTC/CIRCUIT DIAGNOSIS >

- YES >> GO TO 6.  
NO >> Repair open circuit or short to power in harness or connectors.

### 6.CHECK CONDENSER

Refer to [EC-1529. "Component Inspection \(Condenser\)"](#)

Is the inspection result normal?

- YES >> GO TO 7.  
NO >> Replace condenser. Refer to [EM-186. "Exploded View"](#).

### 7.CHECK IGNITION COIL POWER SUPPLY CIRCUIT-IV

1. Reconnect all harness connectors disconnected.
2. Disconnect ignition coil harness connector.
3. Turn ignition switch ON.
4. Check the voltage between ignition coil harness connector and ground.

| Ignition coil |           |          | Ground | Voltage         |
|---------------|-----------|----------|--------|-----------------|
| Cylinder      | Connector | Terminal |        |                 |
| 1             | F91       | 3        | Ground | Battery voltage |
| 2             | F92       | 3        |        |                 |
| 3             | F93       | 3        |        |                 |
| 4             | F94       | 3        |        |                 |
| 5             | F95       | 3        |        |                 |
| 6             | F96       | 3        |        |                 |
| 7             | F97       | 3        |        |                 |
| 8             | F98       | 3        |        |                 |

Is the inspection result normal?

- YES >> GO TO 9.  
NO >> GO TO 8.

### 8.DETECT MALFUNCTIONING PART

Check the following.

- Harness connector F40 or E20
- Harness for open or short between ignition coil and harness connector F40

>> Repair or replace harness or connectors.

### 9.CHECK IGNITION COIL GROUND CIRCUIT FOR OPEN AND SHORT

1. Turn ignition switch OFF.
2. Check the continuity between ignition coil harness connector and ground.

| Ignition coil |           |          | Ground | Continuity |
|---------------|-----------|----------|--------|------------|
| Cylinder      | Connector | Terminal |        |            |
| 1             | F91       | 2        | Ground | Existed    |
| 2             | F92       | 2        |        |            |
| 3             | F93       | 2        |        |            |
| 4             | F94       | 2        |        |            |
| 5             | F95       | 2        |        |            |
| 6             | F96       | 2        |        |            |
| 7             | F97       | 2        |        |            |
| 8             | F98       | 2        |        |            |

3. Also check harness for short to power.

Is the inspection result normal?

# IGNITION SIGNAL

[VK56VD FOR USA AND CANADA]

## < DTC/CIRCUIT DIAGNOSIS >

- YES >> GO TO 10.  
NO >> Repair open circuit or short to power in harness or connectors.

### 10.CHECK IGNITION COIL OUTPUT SIGNAL CIRCUIT FOR OPEN AND SHORT

1. Disconnect ECM harness connector.
2. Check the continuity between ignition coil harness connector and ECM harness connector.

| Ignition coil |           |          | ECM       |          | Continuity |
|---------------|-----------|----------|-----------|----------|------------|
| Cylinder      | Connector | Terminal | Connector | Terminal |            |
| 1             | F91       | 1        | F110      | 12       | Existed    |
| 2             | F92       | 1        |           | 13       |            |
| 3             | F93       | 1        |           | 14       |            |
| 4             | F94       | 1        |           | 15       |            |
| 5             | F95       | 1        |           | 17       |            |
| 6             | F96       | 1        |           | 18       |            |
| 7             | F97       | 1        |           | 19       |            |
| 8             | F98       | 1        |           | 20       |            |

3. Also check harness for short to ground and short to power.

Is the inspection result normal?

- YES >> GO TO 11.  
NO >> Repair open circuit, short to ground or short to power in harness or connectors.

### 11.CHECK IGNITION COIL WITH POWER TRANSISTOR

Refer to [EC-1528, "Component Inspection \(Ignition Coil with Power Transistor\)"](#).

Is the inspection result normal?

- YES >> GO TO 12.  
NO >> Replace malfunctioning ignition coil with power transistor. Refer to [EM-186, "Exploded View"](#).

### 12.CHECK INTERMITTENT INCIDENT

Refer to [GI-44, "Intermittent Incident"](#).

>> INSPECTION END

## Component Inspection (Ignition Coil with Power Transistor)

INFOID:000000007187794

### 1.CHECK IGNITION COIL WITH POWER TRANSISTOR-I

1. Turn ignition switch OFF.
2. Disconnect ignition coil harness connector.
3. Check resistance between ignition coil terminals as per the following.

| Terminals | Resistance [at 25°C (77°F)]   |
|-----------|-------------------------------|
| 1 and 2   | Except 0 or $\infty$ $\Omega$ |
| 1 and 3   | Except 0 $\Omega$             |
| 2 and 3   |                               |

Is the inspection result normal?

- YES >> GO TO 2.  
NO >> Replace malfunctioning ignition coil with power transistor. Refer to [EM-186, "Exploded View"](#).

### 2.CHECK IGNITION COIL WITH POWER TRANSISTOR-II

#### **CAUTION:**

**Perform the following procedure in a place with no combustible objects and good ventilation.**

1. Turn ignition switch OFF.
2. Reconnect all harness connectors disconnected.



# IGNITION SIGNAL

[VK56VD FOR USA AND CANADA]

## < DTC/CIRCUIT DIAGNOSIS >

- Remove fuel pump fuse in IPDM E/R to release fuel pressure.

**NOTE:**

- For the fuse number, refer to [EC-1100. "Wiring Diagram"](#).
- For the fuse arrangement, refer to [PG-41. "Connector and Terminal Arrangement"](#).
- Do not use CONSULT to release fuel pressure, or fuel pressure applies again during the following procedure.

- Start engine.
- After engine stalls, crank it 2 or 3 times to release all fuel pressure.
- Turn ignition switch OFF.
- Remove all ignition coil harness connectors to avoid the electrical discharge from the ignition coils.
- Remove ignition coil and spark plug of the cylinder to be checked. Refer to [EM-186. "Exploded View"](#).
- Crank engine for 5 seconds or more to remove combustion gas in the cylinder.
- Connect spark plug and harness connector to ignition coil.
- Fix ignition coil using a rope etc. with gap of 13 - 17 mm (0.52 - 0.66 in) between the edge of the spark plug and grounded metal portion as shown in the figure.
- Crank engine for approximately 3 seconds, and check whether spark is generated between the spark plug and the grounded metal portion.

**Spark should be generated.**

**CAUTION:**

- Never place the spark plug and the ignition coil within 50 cm (19.7 in) each other. Be careful not to get an electrical shock while checking, because the electrical discharge voltage becomes 20 kV or more.**
- It might damage the ignition coil if the gap of more than 17 mm (0.66 in) is made.**

**NOTE:**

**When the gap is less than 13 mm (0.52 in), a spark might be generated even if the coil is malfunctioning.**

Is the inspection result normal?

YES >> INSPECTION END

NO >> Replace malfunctioning ignition coil with power transistor. Refer to [EM-186. "Exploded View"](#).

## Component Inspection (Condenser)

INFOID:000000007187795

### 1. CHECK CONDENSER

- Turn ignition switch OFF.
- Disconnect condenser harness connector.
- Check resistance between condenser terminals as per the following.

| Terminals | Resistance                  |
|-----------|-----------------------------|
| 1 and 2   | Above 1 MΩ [at 25°C (77°F)] |

Is the inspection result normal?

YES >> INSPECTION END

NO >> Replace condenser.

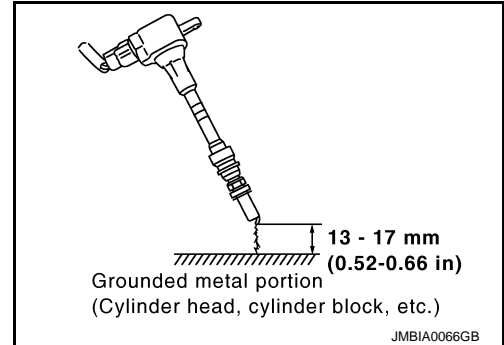

INFORMATION DISPLAY (ASCD)

Component Function Check

INFOID:000000007187796

1. CHECK INFORMATION DISPLAY

1. Start engine.
2. Press MAIN switch on ASCD steering switch.
3. Drive the vehicle at more than 40 km/h (25 MPH).  
**CAUTION:**  
**Always drive vehicle at a safe speed.**
4. Press SET/COAST switch.
5. Check that the reading of the speedometer shows the same value as the set speed indicated in the information display while driving the vehicle on a flat road.

Is the inspection result normal?

- YES >> INSPECTION END  
 NO >> Proceed to [EC-1530, "Diagnosis Procedure"](#).

Diagnosis Procedure

INFOID:000000007187797

1. CHECK DTC

Check that DTC UXXXX, P0500 or P1574 is not displayed.

Is the inspection result normal?

- YES >> GO TO 2.  
 NO-1 >> Perform trouble diagnosis for DTC UXXXX.  
 NO-2 >> Perform trouble diagnosis for DTC P0500. Refer to [EC-1365, "DTC Logic"](#).  
 NO-3 >> Perform trouble diagnosis for DTC P1574. Refer to [EC-1473, "DTC Logic"](#) (Without ICC) or [EC-1475, "DTC Logic"](#) (With ICC).

2. CHECK DTC WITH COMBINATION METER

Refer to [MWI-31, "CONSULT Function"](#).

Is the inspection result normal?

- YES >> GO TO 3.  
 NO >> Perform trouble diagnosis for DTC indicated.

3. CHECK INTERMITTENT INCIDENT

Refer to [GI-44, "Intermittent Incident"](#).

Is the inspection result normal?

- YES >> Replace combination meter. Refer to [MWI-79, "Removal and Installation"](#).  
 NO >> Repair or replace.

# LOW PRESSURE FUEL PUMP

< DTC/CIRCUIT DIAGNOSIS >

[VK56VD FOR USA AND CANADA]

## LOW PRESSURE FUEL PUMP

### Component Function Check

INFOID:000000007187798

#### 1. CHECK FUEL PUMP FUNCTION

1. Turn ignition switch ON.
2. Pinch fuel feed hose with two fingers.

**NOTE:**

Fuel pressure pulsation should be felt on the fuel feed hose for 1 second after ignition switch is turned ON.

Is the inspection result normal?

- YES >> INSPECTION END  
 NO >> [EC-1531, "Diagnosis Procedure"](#).

### Diagnosis Procedure

INFOID:000000007187799

#### 1. CHECK FPCM POWER SUPPLY CIRCUIT

1. Turn ignition switch OFF.
2. Disconnect FPCM harness connector.
3. Turn ignition switch ON.
4. Check the voltage between FPCM harness connector and ground.

| +         |          | -      | Voltage         |
|-----------|----------|--------|-----------------|
| FPCM      |          |        |                 |
| Connector | Terminal |        |                 |
| B221      | 10       | Ground | Battery voltage |

Is the inspection result normal?

- YES >> GO TO 2.  
 NO >> Perform the trouble diagnosis for power supply circuit. Refer to [EC-1149, "Diagnosis Procedure"](#).

#### 2. CHECK FPCM GROUND CIRCUIT

1. Turn ignition switch OFF.
2. Check the continuity between FPCM harness connector and ground.

| +         |          | -      | Continuity |
|-----------|----------|--------|------------|
| FPCM      |          |        |            |
| Connector | Terminal |        |            |
| B221      | 5        | Ground | Existed    |

Is the inspection result normal?

- YES >> GO TO 3.  
 NO >> Repair open circuit or short to power in harness or connectors.

#### 3. CHECK FPCM INPUT AND OUTPUT CIRCUIT

1. Disconnect ECM harness connector.
2. Check the continuity between FPCM harness connector and ECM harness connector.

| +         |          | -         |          | Continuity |
|-----------|----------|-----------|----------|------------|
| FPCM      |          | ECM       |          |            |
| Connector | Terminal | Connector | Terminal |            |
| B221      | 8        | M160      | 125      | Existed    |
|           | 9        |           | 142      |            |

3. Also check harness for short to ground and to power.

Is the inspection result normal?

# LOW PRESSURE FUEL PUMP

[VK56VD FOR USA AND CANADA]

## < DTC/CIRCUIT DIAGNOSIS >

- YES >> GO TO 4.  
NO >> Repair or replace error-detected parts.

### 4.CHECK FUEL PUMP CONTROL CIRCUIT

1. Disconnect fuel level sensor unit and fuel pump (main) harness connector.
2. Check the continuity between FPCM harness connector and fuel level sensor unit and fuel pump (main) harness connector.

| +         |          | -   |          | Continuity |
|-----------|----------|---|----------|------------|
| FPCM      |          | Fuel level sensor unit and fuel pump (main) |          |            |
| Connector | Terminal | Connector                                   | Terminal |            |
| B221      | 6        | B241  | 3        | Existed    |
|           | 7        |   | 1        |            |

3. Also check harness for short to ground and to power.

#### Is the inspection result normal?

- YES >> GO TO 5.  
NO >> Repair or replace error-detected parts.

### 5.CHECK LOW PRESSURE FUEL PUMP

Refer to [EC-1532, "Component Inspection \(Low Pressure Fuel Pump\)"](#).

#### Is the inspection result normal?

- YES >> GO TO 6.  
NO >> Replace low pressure fuel pump. Refer to [FL-6, "Removal and Installation"](#).

### 6.CHECK FPCM

Refer to [EC-1533, "Component Inspection \(FPCM\)"](#).

#### Is the inspection result normal?

- YES >> Check intermittent incident. Refer to [GI-44, "Intermittent Incident"](#).  
NO >> Replace FPCM. Refer to [EC-1555, "Removal and Installation"](#).

## Component Inspection (Low Pressure Fuel Pump)

INFOID:000000007187800

### 1.CHECK FUEL PRESSURE REGULATOR

1. Turn ignition switch OFF.
2. Check low fuel pressure. Refer to [EC-1127, "Work Procedure"](#).

#### Is inspection result normal?

- YES >> INSPECTION END  
NO >> GO TO 2.

### 2.CHECK LOW PRESSURE FUEL PUMP

1. Turn ignition switch OFF.
2. Disconnect fuel level sensor unit and fuel pump (main).
3. Check resistance between fuel level sensor unit and fuel pump (main) terminals as follows.

| +   | - | Condition                | Resistance  |
|---|---|--------------------------|-------------|
| Fuel level sensor unit and fuel pump (main) |   |                          |             |
| Terminals                                   |   |                          |             |
| 1   | 3 | Temperature: 25°C (77°F) | 0.2 - 5.0 Ω |

#### Is the inspection result normal?

- YES >> INSPECTION END  
NO >> Replace fuel level sensor unit and fuel pump (main). Refer to [FL-5, "Exploded View"](#).

# LOW PRESSURE FUEL PUMP

< DTC/CIRCUIT DIAGNOSIS >

[VK56VD FOR USA AND CANADA]

## Component Inspection (FPCM)

INFOID:000000007187801

### 1. CHECK FUEL PUMP CONTROL MODULE (FPCM)

1. Check the voltage between FPCM terminals under the following conditions.

| FPCM      |          |          | Condition   | Voltage      |
|-----------|----------|----------|---|--------------|
| Connector | +        | -        |   |              |
|           | Terminal | Terminal |   |              |
| B221      | 7        | 6        | For 1 second after turning ignition switch ON       | Approx. 10 V |
|           |          |          | More than 1 second after turning ignition switch ON | Approx. 0 V  |
|           |          |          | Idle speed  | Approx. 10 V |

Is the inspection result normal?

YES >> INSPECTION END

NO >> Replace FPCM. Refer to [EC-1555. "Removal and Installation"](#).

A

EC

C

D

E

F

G

H

I

J

K

L

M

N

O

P

# MALFUNCTION INDICATOR LAMP

< DTC/CIRCUIT DIAGNOSIS >

[VK56VD FOR USA AND CANADA]

## MALFUNCTION INDICATOR LAMP

### Component Function Check

INFOID:000000007187802

#### 1.CHECK MIL FUNCTION

---

1. Turn ignition switch ON.
2. Check that MIL illuminates.

Is the inspection result normal?

- YES >> INSPECTION END  
NO >> Proceed to [EC-1534. "Diagnosis Procedure"](#).

#### Diagnosis Procedure

INFOID:000000007187803

#### 1.CHECK DTC

---

Check that DTC UXXXX is not displayed.

Is the inspection result normal?

- YES >> GO TO 2.  
NO >> Perform trouble diagnosis for DTC UXXXX.

#### 2.CHECK DTC WITH COMBINATION METER

---

Refer to [MWI-31. "CONSULT Function"](#).

Is the inspection result normal?

- YES >> GO TO 3.  
NO >> Perform trouble diagnosis for DTC indicated.

#### 3.CHECK INTERMITTENT INCIDENT

---

Refer to [GI-44. "Intermittent Incident"](#).

Is the inspection result normal?

- YES >> Replace combination meter. Refer to [MWI-79. "Removal and Installation"](#).  
NO >> Repair or replace malfunctioning part.

# ON BOARD REFUELING VAPOR RECOVERY (ORVR)

< DTC/CIRCUIT DIAGNOSIS >

[VK56VD FOR USA AND CANADA]

## ON BOARD REFUELING VAPOR RECOVERY (ORVR)

### Component Function Check

INFOID:000000007187804

#### 1.CHECK ORVR FUNCTION

Check whether the following symptoms are present.

- Fuel odor from EVAP canister is strong.
- Cannot refuel/Fuel odor from the fuel filler opening is strong while refueling.

Are any symptoms present?

- YES >> Proceed to [EC-1535, "Diagnosis Procedure"](#).  
NO >> INSPECTION END

#### Diagnosis Procedure

INFOID:000000007187805

#### 1.INSPECTION START

Check whether the following symptoms are present.

- A: Fuel odor from EVAP canister is strong.  
B: Cannot refuel/Fuel odor from the fuel filler opening is strong while refueling.

Which symptom is present?

- A >> GO TO 2.  
B >> GO TO 7.

#### 2.CHECK EVAP CANISTER

1. Remove EVAP canister with EVAP canister vent control valve and EVAP control system pressure sensor attached. Refer to [FL-13, "Exploded View"](#).
2. Weigh the EVAP canister with EVAP canister vent control valve and EVAP control system pressure sensor attached.

**The weight should be less than 2.1 kg (4.6 lb).**

Is the inspection result normal?

- YES >> GO TO 3.  
NO >> GO TO 4.

#### 3.CHECK IF EVAP CANISTER IS SATURATED WITH WATER

Check if water will drain from EVAP canister (1).

- EVAP canister vent control valve (2)

Does water drain from the EVAP canister?

- YES >> GO TO 4.  
NO >> GO TO 6.

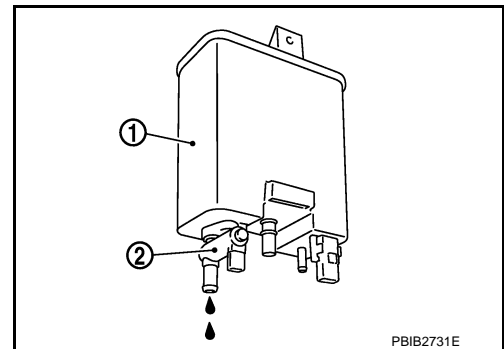

#### 4.REPLACE EVAP CANISTER

Replace EVAP canister with a new one. Refer to [FL-13, "Exploded View"](#).

>> GO TO 5.

#### 5.DETECT MALFUNCTIONING PART

Check the EVAP hose between EVAP canister and vehicle frame for clogging or poor connection.

>> Repair or replace EVAP hose.

#### 6.CHECK REFUELING EVAP VAPOR CUT VALVE

Refer to [EC-1537, "Component Inspection \(EVAP Vapor Cut Valve\)"](#).

# ON BOARD REFUELING VAPOR RECOVERY (ORVR)

[VK56VD FOR USA AND CANADA]

< DTC/CIRCUIT DIAGNOSIS >

Is the inspection result normal?

- YES >> INSPECTION END  
NO >> Replace refueling EVAP vapor cut valve with fuel tank.

## 7. CHECK EVAP CANISTER

1. Remove EVAP canister with EVAP canister vent control valve and EVAP control system pressure sensor attached. Refer to [FL-13, "Exploded View"](#).
2. Weigh the EVAP canister with EVAP canister vent control valve and EVAP control system pressure sensor attached.

**The weight should be less than 2.1 kg (4.6 lb).**

Is the inspection result normal?

- YES >> GO TO 8.  
NO >> GO TO 9.

## 8. CHECK IF EVAP CANISTER IS SATURATED WITH WATER

Check if water will drain from EVAP canister (1).

- EVAP canister vent control valve (2)

Does water drain from the EVAP canister?

- YES >> GO TO 9.  
NO >> GO TO 11.

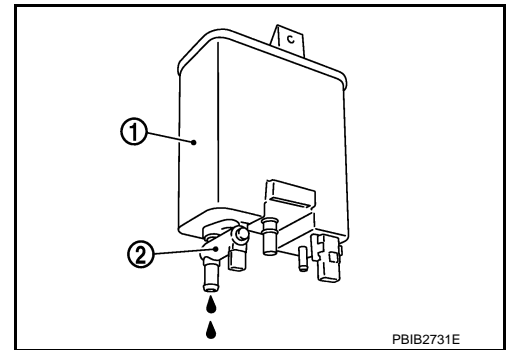

## 9. REPLACE EVAP CANISTER

Replace EVAP canister with a new one. Refer to [FL-13, "Exploded View"](#).

>> GO TO 10.

## 10. DETECT MALFUNCTIONING PART

Check the EVAP hose between EVAP canister and vehicle frame for clogging or poor connection.

>> Repair or replace EVAP hose.

## 11. CHECK VENT HOSES AND VENT TUBES

Check hoses and tubes between EVAP canister and refueling control valve for clogging, kinks, looseness and improper connection.

Is the inspection result normal?

- YES >> GO TO 12.  
NO >> Repair or replace hoses and tubes.

## 12. CHECK FUEL FILLER TUBE

Check recirculation line for clogging, dents and cracks.

Is the inspection result normal?

- YES >> GO TO 13.  
NO >> Replace fuel filler tube. Refer to [FL-10, "Exploded View"](#).

## 13. CHECK REFUELING EVAP VAPOR CUT VALVE

Refer to [EC-1537, "Component Inspection \(EVAP Vapor Cut Valve\)"](#).

Is the inspection result normal?

- YES >> GO TO 14.  
NO >> Replace refueling EVAP vapor cut valve with fuel tank.

## 14. CHECK FUEL FILLER TUBE

Check filler neck tube and hose connected to the fuel tank for clogging, dents and cracks.



# ON BOARD REFUELING VAPOR RECOVERY (ORVR)

[VK56VD FOR USA AND CANADA]

< DTC/CIRCUIT DIAGNOSIS >

Is the inspection result normal?

YES >> GO TO 15.

NO >> Replace fuel filler tube. Refer to [FL-10, "Exploded View"](#).

## 15.CHECK ONE-WAY FUEL VALVE-I

Check one-way fuel valve for clogging.

Is the inspection result normal?

YES >> GO TO 16.

NO >> Repair or replace one-way fuel valve with fuel tank.

## 16.CHECK ONE-WAY FUEL VALVE-II

1. Check that fuel is drained from the tank.
2. Remove fuel filler tube and hose. Refer to [FL-10, "Exploded View"](#).
3. Check one-way fuel valve for operation as per the following.  
When a stick is inserted, the valve should open, when removing stick it should close.

**Do not drop any material into the tank.**

Is the inspection result normal?

YES >> INSPECTION END

NO >> Replace fuel filler tube or replace one-way fuel valve with fuel tank. Refer to [FL-10, "Exploded View"](#).

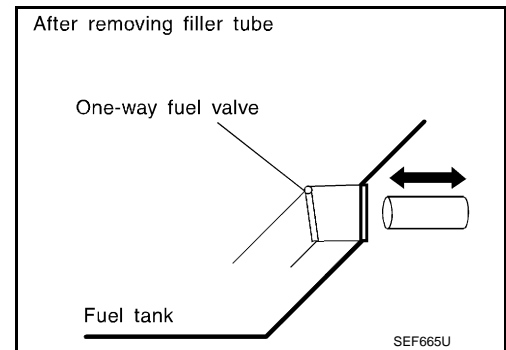

INFOID:000000007187806

## Component Inspection (EVAP Vapor Cut Valve)

### 1.CHECK REFUELING EVAP VAPOR CUT VALVE

1. Turn ignition switch OFF.
2. Remove fuel tank. Refer to [FL-10, "Removal and Installation"](#).
3. Drain fuel from the tank as per the following:
  - Remove fuel gauge retainer. Refer to [FL-5, "Exploded View"](#).
  - Drain fuel from the tank using a handy pump into a fuel container.
4. Check refueling EVAP vapor cut valve for being stuck to close as per the following.  
Blow air into the refueling EVAP vapor cut valve (from the end of EVAP/ORVR line hose), and check that the air flows freely into the tank.
5. Check refueling EVAP vapor cut valve for being stuck to open as per the following.
  - Connect vacuum pump to hose end.
  - Remove fuel gauge retainer with fuel gauge unit. Refer to [FL-5, "Exploded View"](#).

**Always replace O-ring with new one.**

  - Turn fuel tank upside down.

# ON BOARD REFUELING VAPOR RECOVERY (ORVR)

[VK56VD FOR USA AND CANADA]

## < DTC/CIRCUIT DIAGNOSIS >

- Apply vacuum pressure to hose end [-13.3 kPa (-0.136 kg/cm<sup>3</sup>, -1.93 psi)] with fuel gauge retainer remaining open and check that the pressure is applicable.

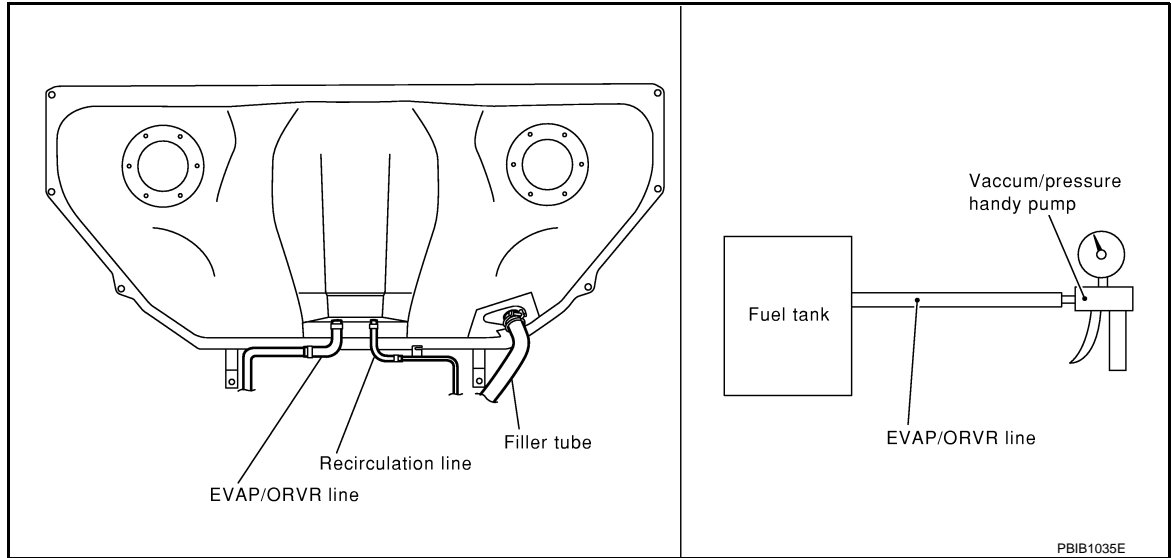

PBIB1035E

Is the inspection result normal?

- YES >> INSPECTION END
- NO >> Replace refueling EVAP vapor cut valve with fuel tank.

# REFRIGERANT PRESSURE SENSOR

< DTC/CIRCUIT DIAGNOSIS >

[VK56VD FOR USA AND CANADA]

## REFRIGERANT PRESSURE SENSOR

### Component Function Check

INFOID:000000007187807

#### 1. CHECK REFRIGERANT PRESSURE SENSOR FUNCTION

1. Start engine and warm it up to normal operating temperature.
2. Turn A/C switch and blower fan switch ON.
3. Check the voltage between ECM harness connector terminals as per the following.

| Connector | ECM   |          | Voltage (V) |
|-----------|---|----------|-------------|
|           | +   | -        |             |
|           | Terminal                                    | Terminal |             |
| M160      | 144<br>(Refrigerant pressure sensor signal) | 150      | 1.0 - 4.0   |

Is the inspection result normal?

- YES >> INSPECTION END  
NO >> Go to [EC-1539, "Diagnosis Procedure"](#).

#### Diagnosis Procedure

INFOID:000000007187808

#### 1. CHECK REFRIGERANT PRESSURE SENSOR POWER SUPPLY CIRCUIT

1. Disconnect refrigerant pressure sensor harness connector.
2. Turn ignition switch ON.
3. Check the voltage between refrigerant pressure sensor harness connector and ground.

| Refrigerant pressure sensor |          | Ground | Voltage (V) |
|-----------------------------|----------|--------|-------------|
| Connector                   | Terminal |        |             |
| E77                         | 3        | Ground | Approx. 5 V |

Is the inspection result normal?

- YES >> GO TO 3.  
NO >> GO TO 2.

#### 2. DETECT MALFUNCTIONING PART

Check the following.

- Harness for open or short between ECM and refrigerant pressure sensor
- Loose or poor connection for each connector and harness

>> Repair open circuit, short to ground or short to power in harness or connectors.

#### 3. CHECK REFRIGERANT PRESSURE SENSOR GROUND CIRCUIT FOR OPEN AND SHORT

1. Turn ignition switch OFF.
2. Disconnect ECM harness connector.
3. Check the continuity between refrigerant pressure sensor harness connector and ECM harness connector.

| Refrigerant pressure sensor |          | ECM       |          | Continuity |
|-----------------------------|----------|-----------|----------|------------|
| Connector                   | Terminal | Connector | Terminal |            |
| E77                         | 1        | M160      | 150      | Existed    |

4. Also check harness for short to ground and short to power.

Is the inspection result normal?

- YES >> GO TO 5.  
NO >> GO TO 4.

# REFRIGERANT PRESSURE SENSOR

< DTC/CIRCUIT DIAGNOSIS >

[VK56VD FOR USA AND CANADA]

## 4. DETECT MALFUNCTIONING PART

Check the following.

- Harness for open or short between ECM and refrigerant pressure sensor
- Loose or poor connection for each connector and harness

>> Repair open circuit, short to ground or short to power in harness or connectors.

## 5. CHECK REFRIGERANT PRESSURE SENSOR INPUT SIGNAL CIRCUIT FOR OPEN AND SHORT

1. Check the continuity between refrigerant pressure sensor harness connector and ECM harness connector.

| Refrigerant pressure sensor |          | ECM       |          | Continuity |
|-----------------------------|----------|-----------|----------|------------|
| Connector                   | Terminal | Connector | Terminal |            |
| E77                         | 2        | M160      | 144      | Existed    |

2. Also check harness for short to ground and short to power.

Is the inspection result normal?

YES >> GO TO 7.

NO >> GO TO 6.

## 6. DETECT MALFUNCTIONING PART

Check the following.

- Harness for open or short between ECM and refrigerant pressure sensor
- Loose or poor connection for each connector and harness

>> Repair open circuit, short to ground or short to power in harness or connectors.

## 7. CHECK INTERMITTENT INCIDENT

Refer to [GI-44, "Intermittent Incident"](#).

Is the inspection result normal?

YES >> Replace refrigerant pressure sensor. Refer to [HA-40, "REFRIGERANT PRESSURE SENSOR : Removal and Installation"](#).

NO >> Repair or replace malfunctioning part.

# ENGINE CONTROL SYSTEM SYMPTOMS

< SYMPTOM DIAGNOSIS >

[VK56VD FOR USA AND CANADA]

## SYMPTOM DIAGNOSIS

### ENGINE CONTROL SYSTEM SYMPTOMS

#### Symptom Table

INFOID:000000007188820

#### SYSTEM — BASIC ENGINE CONTROL SYSTEM

|   |                                       | SYMPTOM                          |              |                              |                        |                                 |                    |                    |                  |                        |                                  |                            |                           | Reference page |  |
|---|---------------------------------------|----------------------------------|--------------|------------------------------|------------------------|---------------------------------|--------------------|--------------------|------------------|------------------------|----------------------------------|----------------------------|---------------------------|----------------|--|
|   |                                       | HARD/NO START/RESTART (EXCP. HA) | ENGINE STALL | HESITATION/SURGING/FLAT SPOT | SPARK KNOCK/DETONATION | LACK OF POWER/POOR ACCELERATION | HIGH IDLE/LOW IDLE | ROUGH IDLE/HUNTING | IDLING VIBRATION | SLOW/NO RETURN TO IDLE | OVERHEATS/WATER TEMPERATURE HIGH | EXCESSIVE FUEL CONSUMPTION | EXCESSIVE OIL CONSUMPTION |                | BATTERY DEAD (UNDER CHARGE)  |
| Warranty symptom code                     |                                       | AA                               | AB           | AC                           | AD                     | AE                              | AF                 | AG                 | AH               | AJ                     | AK                               | AL                         | AM                        | HA             |  |
| Fuel                                      | Low pressure fuel pump circuit        | 1                                | 1            | 2                            | 3                      | 2                               |                    | 2                  | 2                |                        |                                  | 3                          |                           | 2              | <a href="#">EC-1531</a>  |
|   | Low fuel pressure sensor circuit      |                                  |              | 4                            |                        | 4                               |                    |                    |                  |                        |                                  |                            |                           |                | <a href="#">EC-1499</a>  |
|   | Fuel pressure regulator system        | 3                                | 3            | 4                            | 4                      | 4                               | 4                  | 4                  | 4                | 4                      |                                  | 4                          |                           |                | <a href="#">EC-1127</a>  |
|   | Fuel injector circuit                 | 1                                | 1            | 2                            | 3                      | 2                               |                    | 2                  | 2                |                        |                                  | 2                          |                           |                | <a href="#">EC-1517</a>  |
|   | Evaporative emission system           | 3                                | 3            | 4                            | 4                      | 4                               | 4                  | 4                  | 4                | 4                      | 4                                | 4                          |                           |                | <a href="#">EC-1550</a>  |
|   | FRP sensor circuit                    | 1                                | 1            | 2                            | 2                      | 2                               |                    | 2                  | 2                |                        |                                  | 2                          |                           |                | <a href="#">EC-1279</a><br><a href="#">EC-1283</a>   |
|   | High pressure fuel pump circuit       |                                  |              | 4                            |                        | 3                               |                    |                    |                  |                        |                                  |                            |                           |                | <a href="#">EC-1520</a>  |
| Air                                       | Positive crankcase ventilation system | 3                                | 3            | 4                            | 4                      | 4                               | 4                  | 4                  | 4                | 4                      |                                  | 4                          | 1                         |                | <a href="#">EC-1552</a>  |
|   | Incorrect idle speed adjustment       |                                  |              |                              |                        |                                 | 1                  | 1                  | 1                | 1                      |                                  | 1                          |                           |                | <a href="#">EC-1113</a>  |
|   | Electric throttle control actuator    | 1                                | 1            | 2                            | 3                      | 3                               | 2                  | 2                  | 2                | 2                      |                                  | 2                          |                           | 2              | <a href="#">EC-1423</a><br><a href="#">EC-1429</a>   |
| Ignition                                  | Incorrect ignition timing adjustment  | 3                                | 3            | 1                            | 1                      | 1                               |                    | 1                  | 1                |                        |                                  | 1                          |                           |                | <a href="#">EC-1525</a>  |
|   | Ignition circuit                      | 1                                | 1            | 2                            | 2                      | 2                               |                    | 2                  | 2                |                        |                                  | 2                          |                           |                | <a href="#">EC-1525</a>  |
| Main power supply and ground circuit      |                                       | 2                                | 2            | 3                            | 3                      | 3                               |                    | 3                  | 3                |                        | 2                                | 3                          |                           |                | <a href="#">EC-1149</a>  |
| Mass air flow sensor circuit              |                                       | 1                                |              |                              | 2                      |                                 |                    |                    |                  |                        |                                  |                            |                           |                | <a href="#">EC-1159</a>  |
| Engine coolant temperature sensor circuit |                                       |                                  |              |                              | 3                      |                                 |                    |                    |                  |                        |                                  |                            |                           |                |  |
| Air fuel ratio (A/F) sensor 1 circuit     |                                       |                                  | 1            | 2                            | 3                      | 2                               |                    | 2                  | 2                |                        |                                  | 2                          |                           |                | <a href="#">EC-1229</a><br><a href="#">EC-1233</a><br><a href="#">EC-1236</a><br><a href="#">EC-1239</a> |
| Throttle position sensor circuit          |                                       |                                  |              |                              |                        |                                 |                    |                    |                  |                        |                                  |                            |                           |                |  |
| Accelerator pedal position sensor circuit |                                       |                                  |              | 3                            | 2                      | 1                               |                    |                    |                  |                        |                                  |                            |                           |                | <a href="#">EC-1487</a><br><a href="#">EC-1490</a><br><a href="#">EC-1494</a>                            |

# ENGINE CONTROL SYSTEM SYMPTOMS

< SYMPTOM DIAGNOSIS >

[VK56VD FOR USA AND CANADA]

|  | SYMPTOM                          |              |                              |                        |                                 |                    |                    |                  |                        |                                  |                            |                           | Reference page |  |
|--|----------------------------------|--------------|------------------------------|------------------------|---------------------------------|--------------------|--------------------|------------------|------------------------|----------------------------------|----------------------------|---------------------------|----------------|--|
|  | HARD/NO START/RESTART (EXCP. HA) | ENGINE STALL | HESITATION/SURGING/FLAT SPOT | SPARK KNOCK/DETONATION | LACK OF POWER/POOR ACCELERATION | HIGH IDLE/LOW IDLE | ROUGH IDLE/HUNTING | IDLING VIBRATION | SLOW/NO RETURN TO IDLE | OVERHEATS/WATER TEMPERATURE HIGH | EXCESSIVE FUEL CONSUMPTION | EXCESSIVE OIL CONSUMPTION |                | BATTERY DEAD (UNDER CHARGE)                        |
| Warranty symptom code                                | AA                               | AB           | AC                           | AD                     | AE                              | AF                 | AG                 | AH               | AJ                     | AK                               | AL                         | AM                        | HA             |  |
| Knock sensor circuit                                 |                                  |              | 2                            |                        |                                 |                    |                    |                  |                        |                                  | 3                          |                           |                | <a href="#">EC-1303</a>                            |
| Engine oil temperature sensor                        |                                  |              | 4                            |                        | 2                               |                    |                    |                  |                        |                                  | 3                          |                           |                | <a href="#">EC-1287</a><br><a href="#">EC-1291</a> |
| Engine oil pressure sensor                           |                                  |              | 4                            |                        | 4                               | 3                  | 3                  | 3                |                        |                                  | 3                          |                           |                | <a href="#">EC-1373</a>                            |
| Crankshaft position sensor circuit                   | 2                                | 2            |                              |                        |                                 |                    |                    |                  |                        |                                  |                            |                           |                | <a href="#">EC-1305</a>                            |
| Camshaft position sensor circuit                     | 3                                | 2            |                              |                        |                                 |                    |                    |                  |                        |                                  |                            |                           |                | <a href="#">EC-1309</a>                            |
| Vehicle speed signal circuit                         |                                  | 2            | 3                            |                        | 3                               |                    |                    |                  |                        |                                  | 3                          |                           |                | <a href="#">EC-1365</a>                            |
| Power steering pressure sensor circuit               |                                  | 2            |                              |                        |                                 |                    | 3                  | 3                |                        |                                  |                            |                           |                | <a href="#">EC-1379</a>                            |
| ECM  | 2                                | 2            | 3                            | 3                      | 3                               | 3                  | 3                  | 3                | 3                      | 3                                | 3                          |                           |                | <a href="#">EC-1384</a><br><a href="#">EC-1386</a> |
| Intake valve timing control solenoid valve circuit   |                                  | 3            | 2                            |                        | 1                               | 3                  | 2                  | 2                | 3                      |                                  | 3                          |                           |                | <a href="#">EC-1165</a><br><a href="#">EC-1179</a> |
| Exhaust valve timing control solenoid valve circuit  |                                  | 3            | 2                            |                        | 1                               | 3                  | 2                  | 2                | 3                      |                                  | 3                          |                           |                | <a href="#">EC-1169</a><br><a href="#">EC-1182</a> |
| Exhaust valve timing control position sensor circuit | 5                                | 5            | 5                            | 5                      | 5                               |                    | 5                  | 5                |                        |                                  | 5                          |                           |                | <a href="#">EC-1398</a>                            |
| VVEL control module                                  | 3                                |              | 4                            | 4                      | 3                               |                    |                    |                  |                        |                                  |                            |                           |                | <a href="#">EC-1477</a><br><a href="#">EC-1478</a> |
| VVEL actuator motor                                  | 3                                |              | 4                            | 4                      | 3                               |                    |                    |                  |                        |                                  |                            |                           |                | <a href="#">EC-1405</a>                            |
| VVEL actuator motor relay                            | 3                                |              | 4                            | 4                      | 3                               |                    |                    |                  |                        |                                  |                            |                           |                | <a href="#">EC-1408</a>                            |
| VVEL control shaft position sensor                   | 3                                |              | 4                            | 4                      | 3                               |                    |                    |                  |                        |                                  |                            |                           |                | <a href="#">EC-1402</a>                            |
| PNP signal circuit                                   |                                  |              | 3                            |                        | 3                               |                    | 3                  | 3                |                        |                                  | 3                          |                           |                | <a href="#">EC-1391</a>                            |
| Refrigerant pressure sensor circuit                  |                                  | 2            |                              |                        |                                 | 3                  |                    |                  | 3                      |                                  | 4                          |                           |                | <a href="#">EC-1539</a>                            |
| Electrical load signal circuit                       |                                  |              |                              |                        |                                 |                    | 3                  |                  |                        |                                  |                            |                           |                | <a href="#">EC-1515</a>                            |
| Air conditioner circuit                              | 2                                | 2            | 3                            | 3                      | 3                               | 3                  | 3                  | 3                | 3                      |                                  | 3                          |                           | 2              | <a href="#">HAC-68</a>                             |
| ABS actuator and electric unit (control unit)        |                                  |              | 4                            |                        |                                 |                    |                    |                  |                        |                                  |                            |                           |                | <a href="#">BRC-55</a>                             |
| Cooling fan control module                           | 5                                | 5            | 5                            | 5                      | 5                               |                    | 5                  | 5                | 5                      | 4                                | 5                          |                           |                | <a href="#">EC-1510</a>                            |
| Manifold absolute pressure sensor circuit            |                                  |              |                              |                        |                                 |                    |                    |                  |                        |                                  | 3                          |                           |                | <a href="#">EC-1204</a><br><a href="#">EC-1208</a> |

# ENGINE CONTROL SYSTEM SYMPTOMS

< SYMPTOM DIAGNOSIS >

[VK56VD FOR USA AND CANADA]

|                        | SYMPTOM                          |              |                              |                        |                                 |                    |                    |                  |                        |                                  |                            |                           |                             | Reference page  |
|------------------------|----------------------------------|--------------|------------------------------|------------------------|---------------------------------|--------------------|--------------------|------------------|------------------------|----------------------------------|----------------------------|---------------------------|-----------------------------|---|
|                        | HARD/NO START/RESTART (EXCP. HA) | ENGINE STALL | HESITATION/SURGING/FLAT SPOT | SPARK KNOCK/DETONATION | LACK OF POWER/POOR ACCELERATION | HIGH IDLE/LOW IDLE | ROUGH IDLE/HUNTING | IDLING VIBRATION | SLOW/NO RETURN TO IDLE | OVERHEATS/WATER TEMPERATURE HIGH | EXCESSIVE FUEL CONSUMPTION | EXCESSIVE OIL CONSUMPTION | BATTERY DEAD (UNDER CHARGE) |   |
| Warranty symptom code  | AA                               | AB           | AC                           | AD                     | AE                              | AF                 | AG                 | AH               | AJ                     | AK                               | AL                         | AM                        | HA                          |   |
| Battery current sensor |                                  |              |                              |                        |                                 | 4                  | 5                  | 5                |                        |                                  |                            |                           | 3                           | <a href="#">EC-1436</a><br><a href="#">EC-1440</a><br><a href="#">EC-1444</a><br><a href="#">EC-1448</a><br><a href="#">EC-1452</a> |
| Heated oxygen sensor 2 |                                  |              | 6                            |                        | 6                               |                    | 6                  | 6                |                        |                                  | 5                          |                           |                             | <a href="#">EC-1244</a><br><a href="#">EC-1250</a><br><a href="#">EC-1258</a>   |

1 - 6: The numbers refer to the order of inspection.

(continued on next page)

## SYSTEM — ENGINE MECHANICAL & OTHER

|   | SYMPTOM                          |              |                              |                        |                                 |                    |                    |                  |                        |                                  |                            |                           |                             | Reference page       |
|---|----------------------------------|--------------|------------------------------|------------------------|---------------------------------|--------------------|--------------------|------------------|------------------------|----------------------------------|----------------------------|---------------------------|-----------------------------|----------------------|
|   | HARD/NO START/RESTART (EXCP. HA) | ENGINE STALL | HESITATION/SURGING/FLAT SPOT | SPARK KNOCK/DETONATION | LACK OF POWER/POOR ACCELERATION | HIGH IDLE/LOW IDLE | ROUGH IDLE/HUNTING | IDLING VIBRATION | SLOW/NO RETURN TO IDLE | OVERHEATS/WATER TEMPERATURE HIGH | EXCESSIVE FUEL CONSUMPTION | EXCESSIVE OIL CONSUMPTION | BATTERY DEAD (UNDER CHARGE) |                      |
| Warranty symptom code                         | AA                               | AB           | AC                           | AD                     | AE                              | AF                 | AG                 | AH               | AJ                     | AK                               | AL                         | AM                        | HA                          |                      |
| Fuel  |                                  |              |                              |                        |                                 |                    |                    |                  |                        |                                  |                            |                           |                             |                      |
| Fuel tank                                     | 5                                |              |                              |                        |                                 |                    |                    |                  |                        |                                  |                            |                           |                             | <a href="#">FL-4</a> |
| Fuel piping                                   |                                  |              | 5                            | 5                      | 5                               |                    | 5                  | 5                |                        |                                  | 5                          |                           |                             |                      |
| Vapor lock                                    |                                  | 5            |                              |                        |                                 |                    |                    |                  |                        |                                  |                            |                           |                             | —                    |
| Valve deposit                                 |                                  |              |                              |                        |                                 |                    |                    |                  |                        |                                  |                            |                           |                             | —                    |
| Poor fuel (Heavy weight gasoline, Low octane) | 5                                |              | 5                            | 5                      | 5                               |                    | 5                  | 5                |                        |                                  | 5                          |                           |                             | —                    |

# ENGINE CONTROL SYSTEM SYMPTOMS

< SYMPTOM DIAGNOSIS >

[VK56VD FOR USA AND CANADA]

|                       |  | SYMPTOM                          |              |                              |                        |                                 |                    |                    |                  |                        |                                  |                            |                           | Reference<br>page |   |
|-----------------------|--|----------------------------------|--------------|------------------------------|------------------------|---------------------------------|--------------------|--------------------|------------------|------------------------|----------------------------------|----------------------------|---------------------------|-------------------|---|
|                       |  | HARD/NO START/RESTART (EXCP. HA) | ENGINE STALL | HESITATION/SURGING/FLAT SPOT | SPARK KNOCK/DETONATION | LACK OF POWER/POOR ACCELERATION | HIGH IDLE/LOW IDLE | ROUGH IDLE/HUNTING | IDLING VIBRATION | SLOW/NO RETURN TO IDLE | OVERHEATS/WATER TEMPERATURE HIGH | EXCESSIVE FUEL CONSUMPTION | EXCESSIVE OIL CONSUMPTION |                   | BATTERY DEAD (UNDER CHARGE)                   |
| Warranty symptom code |  | AA                               | AB           | AC                           | AD                     | AE                              | AF                 | AG                 | AH               | AJ                     | AK                               | AL                         | AM                        | HA                |   |
| Air                   | Air duct   |                                  |              |                              |                        |                                 |                    |                    |                  |                        |                                  |                            |                           |                   | <a href="#">EM-185</a>                        |
|                       | Air cleaner  |                                  |              |                              |                        |                                 |                    |                    |                  |                        |                                  |                            |                           |                   | <a href="#">EM-184</a>                        |
|                       | Air leakage from air duct<br>(Mass air flow sensor — electric throttle control actuator) |                                  | 5            | 5                            |                        | 5                               |                    | 5                  | 5                |                        |                                  | 5                          |                           |                   | <a href="#">EM-185</a>                        |
|                       | Electric throttle control actuator   | 5                                |              |                              | 5                      |                                 | 5                  |                    |                  | 5                      |                                  |                            |                           |                   | <a href="#">EC-1429</a>                       |
|                       | Air leakage from intake manifold/<br>Collector/Gasket                                    |                                  |              |                              |                        |                                 |                    |                    |                  |                        |                                  |                            |                           |                   | <a href="#">EM-190</a>                        |
| Cranking              | Battery  | 1                                | 1            | 1                            |                        | 1                               |                    |                    | 1                | 1                      |                                  |                            |                           | 1                 | <a href="#">PG-135</a>                        |
|                       | Generator circuit  |                                  |              |                              |                        |                                 |                    |                    |                  |                        |                                  |                            |                           |                   | <a href="#">CHG-11</a>                        |
|                       | Starter circuit  | 3                                |              |                              |                        |                                 |                    |                    |                  |                        |                                  | 1                          |                           |                   | <a href="#">STR-9</a>                         |
|                       | Signal plate   | 6                                |              |                              |                        |                                 |                    |                    |                  |                        |                                  |                            |                           |                   | <a href="#">EM-264</a>                        |
|                       | PNP signal   | 4                                |              |                              |                        |                                 |                    |                    |                  |                        |                                  |                            |                           |                   | <a href="#">TM-102</a>                        |
| Engine                | Cylinder head  |                                  |              |                              |                        |                                 |                    |                    |                  |                        |                                  |                            |                           |                   | <a href="#">EM-270</a>                        |
|                       | Cylinder head gasket   | 5                                | 5            | 5                            | 5                      | 5                               |                    | 5                  | 5                |                        | 4                                | 5                          | 3                         |                   |   |
|                       | Cylinder block   |                                  |              |                              |                        |                                 |                    |                    |                  |                        |                                  |                            |                           |                   | <a href="#">EM-284</a>                        |
|                       | Piston   |                                  |              |                              |                        |                                 |                    |                    |                  |                        |                                  |                            | 4                         |                   |   |
|                       | Piston ring  |                                  |              |                              |                        |                                 |                    |                    |                  |                        |                                  |                            |                           |                   |   |
|                       | Connecting rod   | 6                                | 6            | 6                            | 6                      | 6                               |                    | 6                  | 6                |                        |                                  | 6                          |                           |                   |   |
|                       | Bearing  |                                  |              |                              |                        |                                 |                    |                    |                  |                        |                                  |                            |                           |                   |   |
|                       | Crankshaft   |                                  |              |                              |                        |                                 |                    |                    |                  |                        |                                  |                            |                           |                   |   |
| Valve mechanism       | Timing chain   |                                  |              |                              |                        |                                 |                    |                    |                  |                        |                                  |                            |                           |                   | <a href="#">EM-244</a>                        |
|                       | Camshaft   |                                  |              |                              |                        |                                 |                    |                    |                  |                        |                                  |                            |                           |                   | <a href="#">EM-255</a>                        |
|                       | Intake valve timing control  |                                  |              |                              |                        |                                 |                    |                    |                  |                        |                                  |                            |                           |                   | <a href="#">EM-231</a>                        |
|                       | Exhaust valve timing control   | 5                                | 5            | 5                            | 5                      | 5                               |                    | 5                  | 5                |                        |                                  | 5                          |                           |                   |   |
|                       | Intake valve   |                                  |              |                              |                        |                                 |                    |                    |                  |                        |                                  |                            | 3                         |                   | <a href="#">EM-270</a>                        |
|                       | Exhaust valve  |                                  |              |                              |                        |                                 |                    |                    |                  |                        |                                  |                            |                           |                   |   |
| Exhaust               | Exhaust manifold/Tube/Muffler/<br>Gasket   | 5                                | 5            | 5                            | 5                      | 5                               |                    | 5                  | 5                |                        |                                  | 5                          |                           |                   | <a href="#">MA-39</a><br><a href="#">EX-8</a> |
|                       | Three way catalyst   |                                  |              |                              |                        |                                 |                    |                    |                  |                        |                                  |                            |                           |                   |   |



# ENGINE CONTROL SYSTEM SYMPTOMS

< SYMPTOM DIAGNOSIS >

[VK56VD FOR USA AND CANADA]

|   |   | SYMPTOM                          |              |                              |                        |                                 |                    |                    |                  |                        |                                  |                            |                           | Reference<br>page |  |
|---|---|----------------------------------|--------------|------------------------------|------------------------|---------------------------------|--------------------|--------------------|------------------|------------------------|----------------------------------|----------------------------|---------------------------|-------------------|--|
|   |   | HARD/NO START/RESTART (EXCP. HA) | ENGINE STALL | HESITATION/SURGING/FLAT SPOT | SPARK KNOCK/DETONATION | LACK OF POWER/POOR ACCELERATION | HIGH IDLE/LOW IDLE | ROUGH IDLE/HUNTING | IDLING VIBRATION | SLOW/NO RETURN TO IDLE | OVERHEATS/WATER TEMPERATURE HIGH | EXCESSIVE FUEL CONSUMPTION | EXCESSIVE OIL CONSUMPTION |                   | BATTERY DEAD (UNDER CHARGE)  |
| Warranty symptom code                             |   | AA                               | AB           | AC                           | AD                     | AE                              | AF                 | AG                 | AH               | AJ                     | AK                               | AL                         | AM                        | HA                |  |
| Lubrica-<br>tion                                  | Oil pan/Oil strainer/Oil pump/Oil filter/Oil gallery/Oil cooler | 5                                | 5            | 5                            | 5                      | 5                               |                    |                    | 5                | 5                      |                                  | 5                          |                           |                   | <a href="#">EM-206</a><br><a href="#">EM-209</a><br><a href="#">LU-28</a><br><a href="#">LU-29</a> |
|   | Oil level (Low)/Filthy oil                                      |                                  |              |                              |                        |                                 |                    |                    |                  |                        |                                  |                            |                           |                   | <a href="#">LU-23</a>  |
| Cooling   | Radiator/Hose/Radiator filler cap                               |                                  |              |                              |                        |                                 |                    |                    |                  |                        |                                  |                            |                           |                   | <a href="#">MA-34</a><br><a href="#">MA-35</a>   |
|   | Thermostat  |                                  |              |                              |                        |                                 |                    |                    |                  | 5                      |                                  |                            |                           |                   | <a href="#">CO-49</a>  |
|   | Water pump  |                                  |              |                              |                        |                                 |                    |                    |                  |                        |                                  |                            |                           |                   | <a href="#">CO-47</a>  |
|   | Water gallery   | 5                                | 5            | 5                            | 5                      | 5                               |                    | 5                  | 5                |                        | 4                                | 5                          |                           |                   | <a href="#">CO-49</a>  |
|   | Cooling fan   |                                  |              |                              |                        |                                 |                    |                    |                  |                        |                                  |                            |                           |                   | <a href="#">CO-45</a>  |
|   | Coolant level (Low)/Contaminated coolant                        |                                  |              |                              |                        |                                 |                    |                    |                  |                        | 5                                |                            |                           |                   | <a href="#">CO-34</a>  |
| IVIS (INFINITI Vehicle Immobilizer System — NATS) |   | 1                                | 1            |                              |                        |                                 |                    |                    |                  |                        |                                  |                            |                           |                   | <a href="#">SEC-36</a>   |

1 - 6: The numbers refer to the order of inspection.

A  
EC  
C  
D  
E  
F  
G  
H  
I  
J  
K  
L  
M  
N  
O  
P

# INFINITI DRIVE MODE SELECTOR

< SYMPTOM DIAGNOSIS >

[VK56VD FOR USA AND CANADA]

## INFINITI DRIVE MODE SELECTOR

### Symptom Table

INFOID:000000007188821

#### SYSTEM - DRIVE MODE SELECTOR -

| Malfunction  | Check item  |   | Probable malfunctioning part/<br>Action  |
|--|---|---|--|
| ECO pedal reaction force is not generated when in ECO mode.  | Only ECO pedal reaction force is not generated.<br>[Intelligent pedal (distance control assist) operates normally.] | The central switch of the navigation system operates normally.  | Perform self-diagnosis of the engine control system.<br>Refer to <a href="#">EC-1083</a> , " <a href="#">DTC Index</a> ".  |
|  |   | The central switch of the navigation system malfunctions.   | Perform self-diagnosis of the navigation system.<br>Refer to <a href="#">AV-97</a> , " <a href="#">Symptom Table</a> " (BASE AUDIO WITHOUT NAVIGATION) or <a href="#">AV-252</a> , " <a href="#">Symptom Table</a> " (BOSE AUDIO WITH NAVIGATION)  |
| Intelligent pedal (distance control assist) reaction force is not generated as well.   |   |   | Perform self-diagnosis of the ADAS control unit, ICC sensor, and Accelerator pedal actuator.<br><ul style="list-style-type: none"> <li>• ADAS C/U: Refer to <a href="#">DAS-40</a>, "<a href="#">DTC Index</a>".</li> <li>• ICC SENSOR: Refer to <a href="#">DAS-98</a>, "<a href="#">DTC Index</a>".</li> <li>• ACCELERATOR PEDAL ACTUATOR: Refer to <a href="#">DAS-101</a>, "<a href="#">DTC Index</a>".</li> </ul> |
| When in ECO mode, settings of ECO pedal reaction force cannot be changed or vehicle behavior does not agree to the settings. | Intelligent pedal (distance control assist) reaction force has a malfunction as well.                               |   | Perform self-diagnosis of the ADAS control unit, ICC sensor, and Accelerator pedal actuator.<br><ul style="list-style-type: none"> <li>• ADAS C/U: Refer to <a href="#">DAS-92</a>, "<a href="#">DTC Index</a>".</li> <li>• ICC SENSOR: Refer to <a href="#">DAS-98</a>, "<a href="#">DTC Index</a>".</li> <li>• ACCELERATOR PEDAL ACTUATOR: Refer to <a href="#">DAS-101</a>, "<a href="#">DTC Index</a>".</li> </ul> |
|  | Intelligent pedal (distance control assist) reaction force is normal.   | The central switch of the navigation system operates normally.  | Perform self-diagnosis of the engine control system.<br>Refer to <a href="#">EC-1083</a> , " <a href="#">DTC Index</a> ".  |
| The central switch of the navigation system malfunctions.  |   | Perform self-diagnosis of the navigation system.<br>Refer to <a href="#">AV-97</a> , " <a href="#">Symptom Table</a> " (BASE AUDIO WITHOUT NAVIGATION) or <a href="#">AV-252</a> , " <a href="#">Symptom Table</a> " (BOSE AUDIO WITH NAVIGATION) |  |

# NORMAL OPERATING CONDITION

< SYMPTOM DIAGNOSIS >

[VK56VD FOR USA AND CANADA]

## NORMAL OPERATING CONDITION

### Description

INFOID:000000007188822

#### FUEL CUT CONTROL (AT NO LOAD AND HIGH ENGINE SPEED)

If the engine speed is above 2,400 rpm under no load (for example, the selector lever position is neutral and engine speed is over 2,400 rpm) fuel will be cut off after some time. The exact time when the fuel is cut off varies based on engine speed.

Fuel cut will be operated until the engine speed reaches 1,000 rpm, then fuel cut will be cancelled.

#### NOTE:

This function is different from deceleration control listed under direct injection gasoline system, [EC-1012](#), "[DIRECT INJECTION GASOLINE SYSTEM : System Description](#)".

A

EC

C

D

E

F

G

H

I

J

K

L

M

N

O

P

---

# PERIODIC MAINTENANCE

## IDLE SPEED

Inspection

INFOID:000000007188823

### 1. CHECK IDLE SPEED

---

- ④ With CONSULT  
Check idle speed in "DATA MONITOR" mode with CONSULT.
- ④ With GST  
Check idle speed with Service \$01 of GST.

>> INSPECTION END

# IGNITION TIMING

< PERIODIC MAINTENANCE >

[VK56VD FOR USA AND CANADA]

## IGNITION TIMING

### Inspection

INFOID:000000007188824

### 1. CHECK IGNITION TIMING

1. Attach timing light to loop wire as shown.

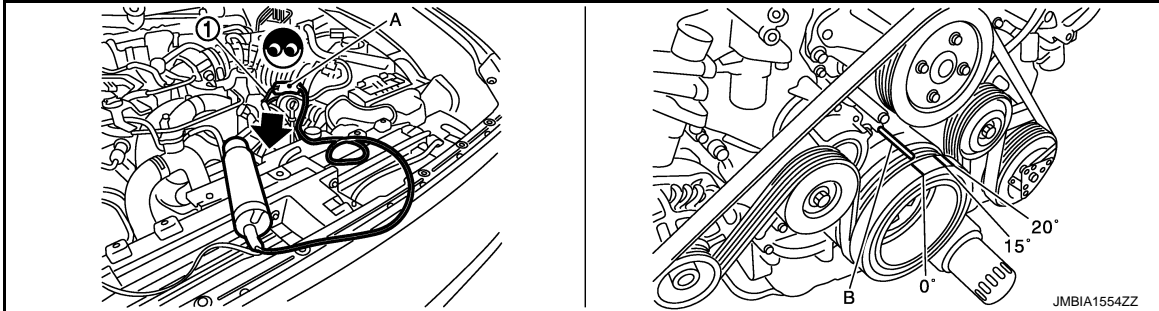

1. Loop wire
- A. Timing light
- B. Timing indicator

2. Check ignition timing.

>> INSPECTION END

A

EC

C

D

E

F

G

H

I

J

K

L

M

N

O

P

# EVAP LEAK CHECK

< PERIODIC MAINTENANCE >

[VK56VD FOR USA AND CANADA]

## EVAP LEAK CHECK

### Inspection

INFOID:000000007188825

#### CAUTION:

- Do not use compressed air or a high pressure pump.
- Do not exceed 4.12 kPa (0.042 kg/cm<sup>2</sup>, 0.6 psi) of pressure in EVAP system.

#### NOTE:

- Do not start engine.
- Improper installation of EVAP service port adapter (commercial service tool) to the EVAP service port may cause a leak.

#### Ⓟ WITH CONSULT

1. To locate the EVAP leak, install EVAP service port adapter (commercial service tool) and pressure pump to EVAP service port.
2. Turn ignition switch ON.
3. Select the "EVAP SYSTEM CLOSE" of "WORK SUPPORT" mode with CONSULT.
4. Touch "START". A bar graph (Pressure indicating display) will appear on the screen.
5. Apply positive pressure to the EVAP system until the pressure indicator reaches the middle of the bar graph.
6. Remove EVAP service port adapter (commercial service tool) and hose with pressure pump.
7. Locate the leak using a leak detector (commercial service tool). Refer to [EC-1022, "EVAPORATIVE EMISSION SYSTEM : System Diagram"](#).

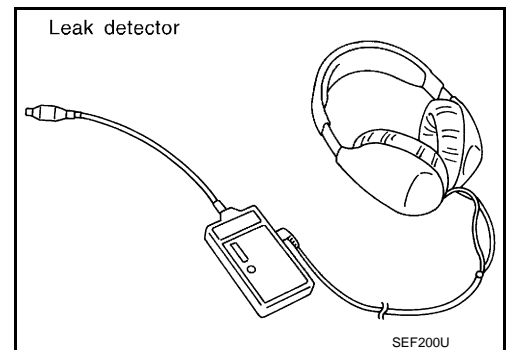
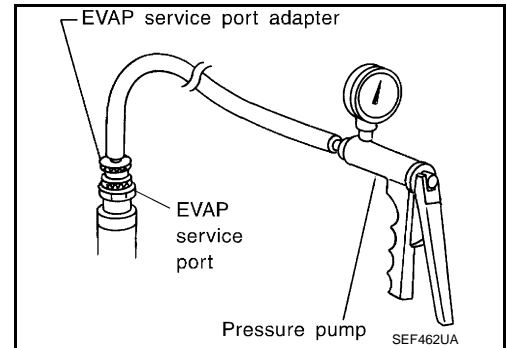

#### ⓧ WITHOUT CONSULT

1. To locate the EVAP leak, install EVAP service port adapter (commercial service tool) and pressure pump to EVAP service port.
2. Apply battery voltage between the terminals of EVAP canister vent control valve to make a closed EVAP system.
3. To locate the leak, deliver positive pressure to the EVAP system until pressure gauge points reach 1.38 to 2.76 kPa (0.014 to 0.028 kg/cm<sup>2</sup>, 0.2 to 0.4 psi).
4. Remove EVAP service port adapter (commercial service tool) and hose with pressure pump.

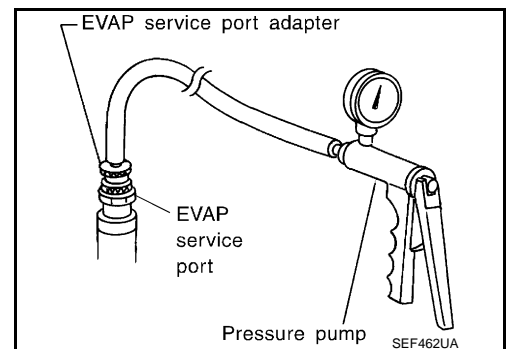

# EVAP LEAK CHECK

< PERIODIC MAINTENANCE >

[VK56VD FOR USA AND CANADA]

5. Locate the leak using a leak detector (commercial service tool). Refer to [EC-1022, "EVAPORATIVE EMISSION SYSTEM : System Diagram"](#).

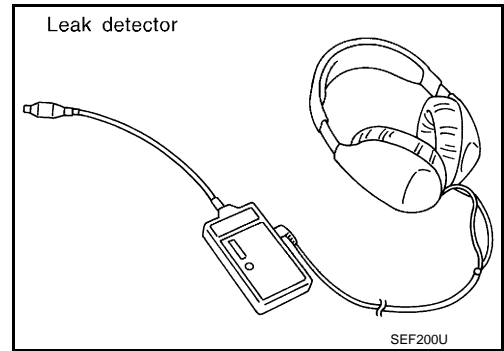

A  
EC  
C  
D  
E  
F  
G  
H  
I  
J  
K  
L  
M  
N  
O  
P

# POSITIVE CRANKCASE VENTILATION

< PERIODIC MAINTENANCE >

[VK56VD FOR USA AND CANADA]

## POSITIVE CRANKCASE VENTILATION

### Inspection

INFOID:000000007188826

#### 1. CHECK PCV VALVE

With engine running at idle, remove PCV valve from rocker cover. Refer to [EM-186. "Exploded View"](#). A properly working valve makes a hissing noise as air passes through it. A strong vacuum should be felt immediately when a finger is placed over valve inlet.

Is the inspection result normal?

YES >> INSPECTION END

NO >> Replace PCV valve. Refer to [EM-186. "Exploded View"](#).

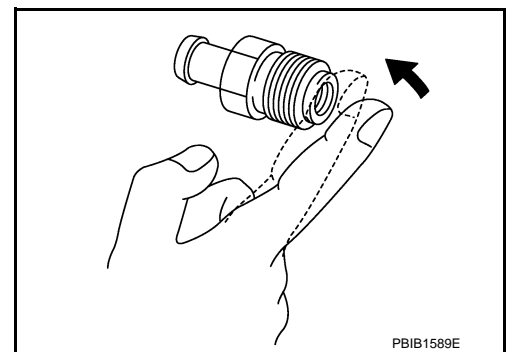



# REMOVAL AND INSTALLATION

## ECM

### Removal and Installation

INFOID:000000007188827

#### REMOVAL

1. Remove the instrument lower cover. Refer to [IP-24, "Removal and Installation"](#).
2. Remove the dash side finisher (LH). Refer to [INT-34, "DASH SIDE FINISHER : Removal and Installation"](#).
3. Remove the ECM cover bolts (A) and remove ECM cover (1).

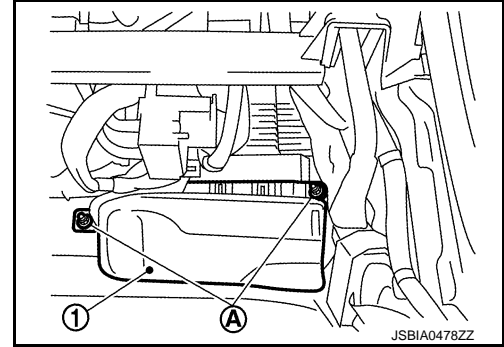

4. Disconnect ECM harness connectors.
5. Remove ECM bracket bolt (A)
6. Slide the ECM bracket (1) upward and then remove ECM bracket with ECM.
7. Remove ECM bracket bolts (B) and separate ECM (2) and ECM bracket.

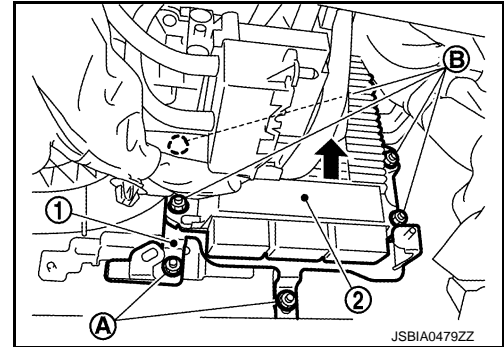

#### INSTALLATION

Install in the reverse order of removal.

**CAUTION:**

**Must be perform additional service when replacing ECM. Refer to [EC-1117, "Work Procedure"](#).**

# VVEL CONTROL MODULE

< REMOVAL AND INSTALLATION >

[VK56VD FOR USA AND CANADA]

## VVEL CONTROL MODULE

### Removal and Installation

INFOID:000000007188828

#### REMOVAL

1. Remove hoodledge cover (RH) and cowl top cover (RH). Refer to [EXT-21, "Removal and Installation"](#).
2. Remove the battery and battery tray. Refer to [PG-142, "Removal and Installation"](#).
3. Remove VVEL control module bracket bolts (A).
4. Remove the ground harness fix bolt (B).
5. Remove VVEL control module bracket (1).

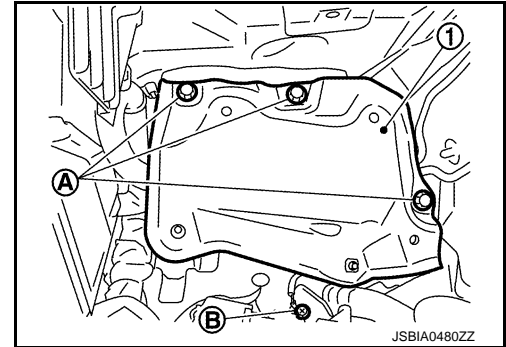

6. Disconnect VVEL control module harness connector.
7. Remove the fix bolts (A). And then separate VVEL control module (1), ground harness (2) and VVEL control module bracket (3).

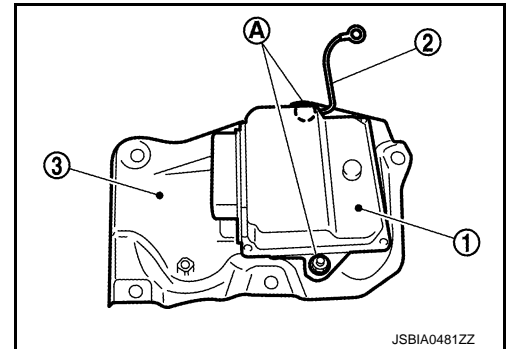

#### INSTALLATION

Install in the reverse order of removal.

#### **CAUTION:**

**Must be perform additional service when replacing VVEL control module. Refer to [EC-1118, "Work Procedure"](#).**

# FUEL PUMP CONTROL MODULE (FPCM)

< REMOVAL AND INSTALLATION >

[VK56VD FOR USA AND CANADA]

## FUEL PUMP CONTROL MODULE (FPCM)

### Removal and Installation

INFOID:000000007188829

#### REMOVAL

1. Remove the rear wheel house finisher (RH). Refer to [INT-51, "TRUNK SIDE FINISHER : Removal and Installation"](#).
2. Disconnect fuel pump control module (FPCM) connector.
3. Remove mounting bolts and then remove fuel pump control module (FPCM).

#### INSTALLATION

Install in the reverse order of removal.

A

EC

C

D

E

F

G

H

I

J

K

L

M

N

O

P

## SERVICE DATA AND SPECIFICATIONS (SDS)

< SERVICE DATA AND SPECIFICATIONS (SDS)

[VK56VD FOR USA AND CANADA]

# SERVICE DATA AND SPECIFICATIONS (SDS)

## SERVICE DATA AND SPECIFICATIONS (SDS)

### Idle Speed

INFOID:000000007188835

| Condition                     | Specification   |
|-------------------------------|---|
| No load* (in P or N position) | 600 ± 50 rpm (Without 4WAS)<br>675 ± 50 rpm (With 4WAS) |

\*: Under the following conditions

- A/C switch: OFF
- Electric load: OFF (Lights, heater fan & rear window defogger)
- Steering wheel: Kept in straight-ahead position

### Ignition Timing

INFOID:000000007188836

| Condition                     | Specification |
|-------------------------------|---------------|
| No load* (in P or N position) | 11 ± 2°BTDC   |

\*: Under the following conditions

- A/C switch: OFF
- Electric load: OFF (Lights, heater fan & rear window defogger)
- Steering wheel: Kept in straight-ahead position

### Calculated Load Value

INFOID:000000007188837

| Condition    | Specification (Using CONSULT or GST) |
|--------------|--------------------------------------|
| At idle      | 5 – 35%                              |
| At 2,500 rpm | 5 – 35%                              |

### Mass Air Flow Sensor

INFOID:000000007188838

|                                      |  |
|--------------------------------------|--|
| Supply voltage                       | Battery voltage (11 – 14 V)                            |
| Output voltage at idle               | 0.95 – 1.35 V*   |
| Mass air flow (Using CONSULT or GST) | 1.0 – 5.0 g/s at idle*<br>7.0 – 20.0 g/s at 2,500 rpm* |

\*: Engine is warmed up to normal operating temperature and running under no load.

PRECAUTION

PRECAUTIONS

Precaution for Supplemental Restraint System (SRS) "AIR BAG" and "SEAT BELT PRE-TENSIONER"

INFOID:000000007806523

The Supplemental Restraint System such as "AIR BAG" and "SEAT BELT PRE-TENSIONER", used along with a front seat belt, helps to reduce the risk or severity of injury to the driver and front passenger for certain types of collision. This system includes seat belt switch inputs and dual stage front air bag modules. The SRS system uses the seat belt switches to determine the front air bag deployment, and may only deploy one front air bag, depending on the severity of a collision and whether the front occupants are belted or unbelted. Information necessary to service the system safely is included in the "SRS AIR BAG" and "SEAT BELT" of this Service Manual.

**WARNING:**

Always observe the following items for preventing accidental activation.

- To avoid rendering the SRS inoperative, which could increase the risk of personal injury or death in the event of a collision that would result in air bag inflation, all maintenance must be performed by an authorized NISSAN/INFINITI dealer.
- Improper maintenance, including incorrect removal and installation of the SRS, can lead to personal injury caused by unintentional activation of the system. For removal of Spiral Cable and Air Bag Module, see "SRS AIR BAG".
- Never use electrical test equipment on any circuit related to the SRS unless instructed to in this Service Manual. SRS wiring harnesses can be identified by yellow and/or orange harnesses or harness connectors.

PRECAUTIONS WHEN USING POWER TOOLS (AIR OR ELECTRIC) AND HAMMERS

**WARNING:**

Always observe the following items for preventing accidental activation.

- When working near the Air Bag Diagnosis Sensor Unit or other Air Bag System sensors with the ignition ON or engine running, never use air or electric power tools or strike near the sensor(s) with a hammer. Heavy vibration could activate the sensor(s) and deploy the air bag(s), possibly causing serious injury.
- When using air or electric power tools or hammers, always switch the ignition OFF, disconnect the battery, and wait at least 3 minutes before performing any service.

Precaution for Procedure without Cowl Top Cover

INFOID:000000007758086

When performing the procedure after removing cowl top cover, cover the lower end of windshield with urethane, etc.

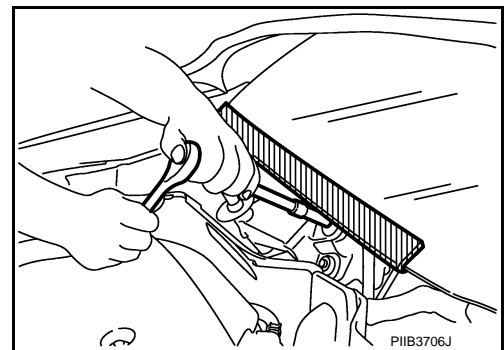

Precautions For Xenon Headlamp Service

INFOID:000000007786695

**WARNING:**

Comply with the following warnings to prevent any serious accident.

- Disconnect the battery cable (negative terminal) or the power supply fuse before installing, removing, or touching the xenon headlamp (bulb included). The xenon headlamp contains high-voltage generated parts.
- Never work with wet hands.
- Check the xenon headlamp ON-OFF status after assembling it to the vehicle. Never turn the xenon headlamp ON in other conditions. Connect the power supply to the vehicle-side connector.

A  
EC  
C  
D  
E  
F  
G  
H  
I  
J  
K  
L  
M  
N  
O  
P

# PRECAUTIONS

[VK56VD FOR MEXICO]

< PRECAUTION >

(Turning it ON outside the lamp case may cause fire or visual impairments.)

- Never touch the bulb glass immediately after turning it OFF. It is extremely hot.

## CAUTION:

Comply with the following cautions to prevent any error and malfunction.

- Install the xenon bulb securely. (Insufficient bulb socket installation may melt the bulb, the connector, the housing, etc. by high-voltage leakage or corona discharge.)
- Never perform HID circuit inspection with a tester.
- Never touch the xenon bulb glass with hands. Never put oil and grease on it.
- Dispose of the used xenon bulb after packing it in thick vinyl without breaking it.
- Never wipe out dirt and contamination with organic solvent (thinner, gasoline, etc.).

## On Board Diagnostic (OBD) System of Engine and A/T

INFOID:000000007758088

The ECM has an on board diagnostic system. It will illuminate the malfunction indicator lamp (MIL) to warn the driver of a malfunction causing emission deterioration.

## CAUTION:

- Always turn the ignition switch OFF and disconnect the negative battery cable before any repair or inspection work. The open/short circuit of related switches, sensors, solenoid valves, etc. will cause the MIL to illuminate.
- Always connect and lock the connectors securely after work. A loose (unlocked) connector will cause the MIL to illuminate due to the open circuit. (Be sure the connector is free from water, grease, dirt, bent terminals, etc.)
- Certain systems and components, especially those related to OBD, may use a new style slide-locking type harness connector. For description and how to disconnect, refer to [EC-1603, "Diagnosis Description"](#).
- Always route and secure the harnesses properly after work. The interference of the harness with a bracket, etc. may cause the MIL to illuminate due to the short circuit.
- Always connect rubber tubes properly after work. A misconnected or disconnected rubber tube may cause the MIL to illuminate due to the malfunction of the EVAP system or fuel injection system, etc.
- Always erase the unnecessary malfunction information (repairs completed) from the ECM and TCM (Transmission control module) before returning the vehicle to the customer.

## General Precautions

INFOID:000000007758089

- Always use a 12 volt battery as power source.
- Never attempt to disconnect battery cables while engine is running.
- Before connecting or disconnecting the ECM harness connector, turn ignition switch OFF and disconnect negative battery cable. Failure to do so may damage the ECM because battery voltage is applied to ECM even if ignition switch is turned OFF.
- Before removing parts, turn ignition switch OFF and then disconnect battery ground cable.

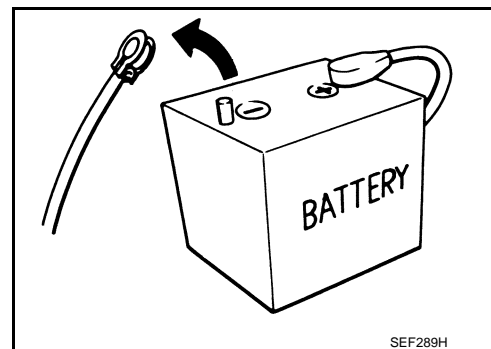

- Never disassemble ECM.
- If a battery cable is disconnected, the memory will return to the ECM value.  
The ECM will now start to self-control at its initial value. Thus, engine operation can vary slightly in this case. However, this is not an indication of a malfunction. Never replace parts because of a slight variation.
- If the battery is disconnected, the following emission-related diagnostic information will be lost within 24 hours.

- Diagnostic trouble codes
- 1st trip diagnostic trouble codes
- Freeze frame data
- 1st trip freeze frame data
- System readiness test (SRT) codes
- Test values

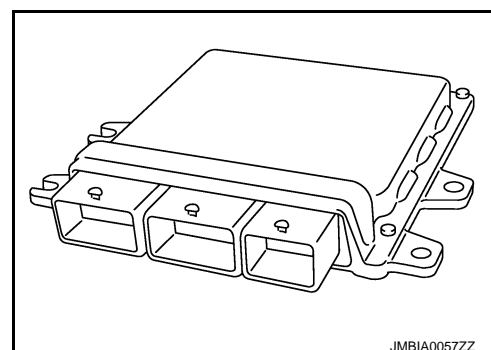

# PRECAUTIONS

[VK56VD FOR MEXICO]

## < PRECAUTION >

- When connecting ECM harness connector (A), fasten (B) it securely with a lever as far as it will go as shown in the figure.
  - ECM (1)
  - Loosen (C)

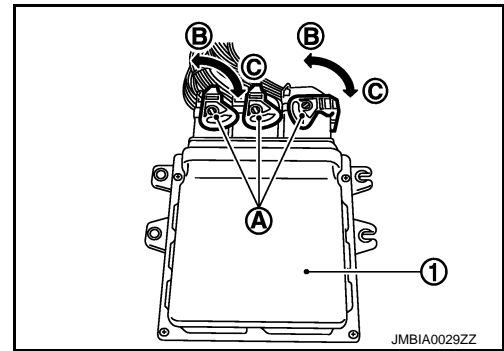

- When connecting or disconnecting pin connectors into or from ECM, never damage pin terminals (bends or break). Check that there are not any bends or breaks on ECM pin terminal, when connecting pin connectors.
- Securely connect ECM harness connectors. A poor connection can cause an extremely high (surge) voltage to develop in coil and condenser, thus resulting in damage to ICs.
- Keep engine control system harness at least 10 cm (4 in) away from adjacent harness, to prevent engine control system malfunctions due to receiving external noise, degraded operation of ICs, etc.
- Keep engine control system parts and harness dry.
- Before replacing ECM, perform ECM Terminals and Reference Value inspection and check that ECM functions properly. Refer to [EC-1624, "Reference Value"](#).
- Handle mass air flow sensor carefully to avoid damage.
- Never clean mass air flow sensor with any type of detergent.
- Never disassemble electric throttle control actuator.
- Even a slight leakage in the air intake system can cause serious incidents.
- Never shock or jar the camshaft position sensor, crankshaft position sensor.

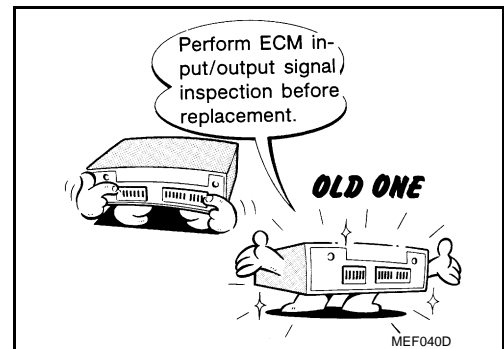
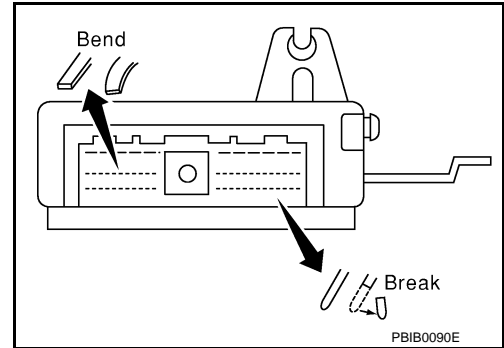

- After performing each TROUBLE DIAGNOSIS, perform DTC Confirmation Procedure or Component Function Check. The DTC should not be displayed in the DTC Confirmation Procedure if the repair is completed. The Component Function Check should be a good result if the repair is completed.

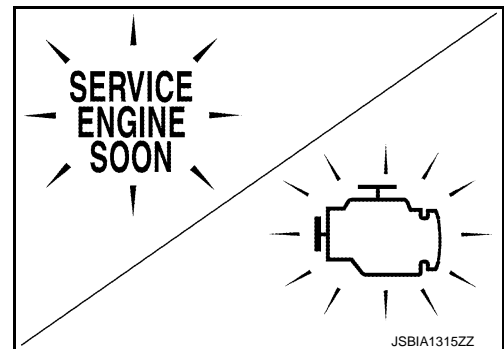

A  
EC  
C  
D  
E  
F  
G  
H  
I  
J  
K  
L  
M  
N  
O  
P

# PRECAUTIONS

[VK56VD FOR MEXICO]

## < PRECAUTION >

- When measuring ECM signals with a circuit tester, never allow the two tester probes to contact. Accidental contact of probes will cause a short circuit and damage the ECM power transistor.

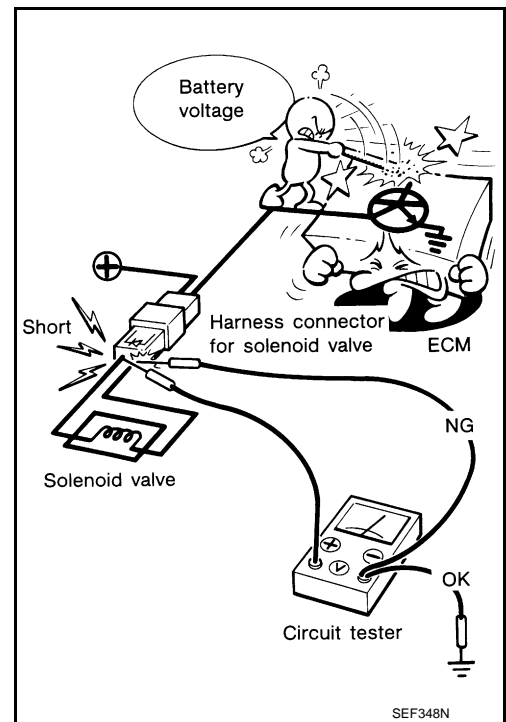

- B1 indicates bank 1, B2 indicates bank 2 as shown in the figure.
- Never operate fuel pump when there is no fuel in lines.
- Tighten fuel hose clamps to the specified torque.

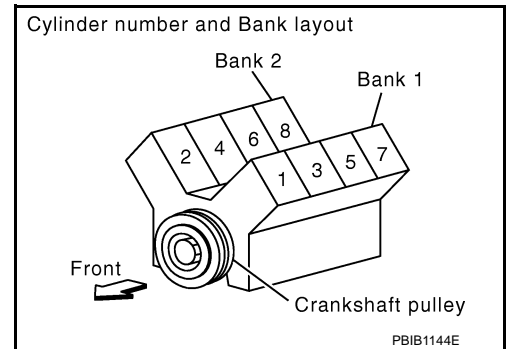

- Never depress accelerator pedal when starting.
- Immediately after starting, never rev up engine unnecessarily.
- Never rev up engine just prior to shutdown.

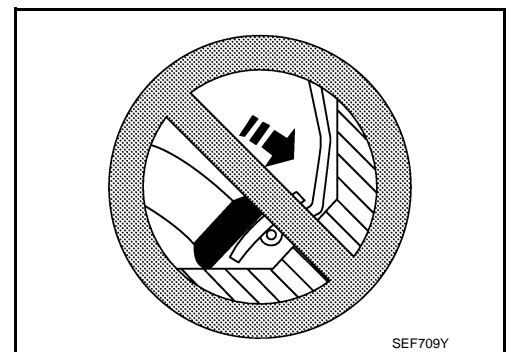



# PRECAUTIONS

[VK56VD FOR MEXICO]

## < PRECAUTION >

- When installing C.B. ham radio or a mobile phone, be sure to observe the following as it may adversely affect electronic control systems depending on installation location.
- Keep the antenna as far as possible from the electronic control units.
- Keep the antenna feeder line more than 20 cm (8 in) away from the harness of electronic controls. Never let them run parallel for a long distance.
- Adjust the antenna and feeder line so that the standing-wave ratio can be kept smaller.
- Be sure to ground the radio to vehicle body.

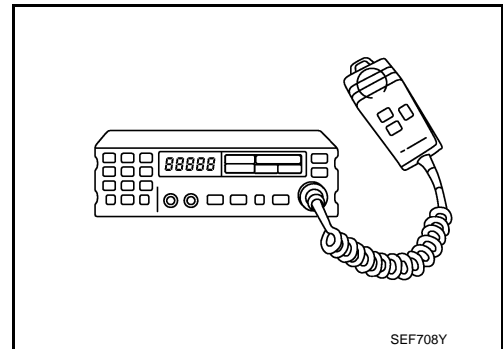

A

EC

C

D

E

F

G

H

I

J

K

L

M

N

O

P

# PREPARATION

< PREPARATION >

[VK56VD FOR MEXICO]

## PREPARATION

### PREPARATION

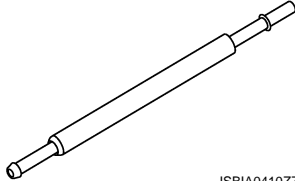

#### Special Service Tools

INFOID:000000007758090

| Tool number<br>(Kent-Moore No.)<br>Tool name   | Description             |
|--|-------------------------|
| KV10120000<br>(—)<br>Fuel tube adapter   | Measuring fuel pressure |
|  <p>JSBIA0410ZZ</p> |                         |

#### Commercial Service Tools

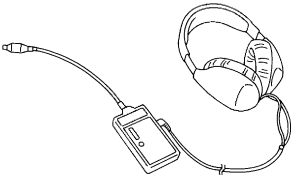
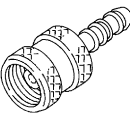

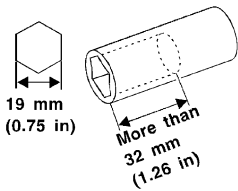
INFOID:000000007758091

| Tool name<br>(Kent-Moore No.)  | Description  |
|--|--|
| Leak detector<br>i.e.: (J-41416)   | Locates the EVAP leak                                  |
|  <p>S-NT703</p>  |  |
| EVAP service port<br>adapter<br>i.e.: (J-41413-OB)   | Applies positive pressure through EVAP service port    |
|  <p>S-NT704</p> |  |
| Fuel filler cap adapter<br>i.e.: (MLR-8382)  | Checks fuel tank vacuum relief valve opening pressure  |
|  <p>S-NT815</p> |  |
| Socket wrench  | Removes and installs engine coolant temperature sensor |
|  <p>S-NT705</p> |  |

# PREPARATION

< PREPARATION >

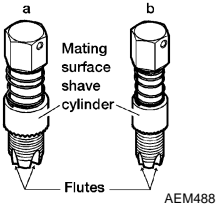
[VK56VD FOR MEXICO]

| Tool name<br>(Kent-Moore No.)   | Description  | A                          |
|---|--|----------------------------|
| <p>Oxygen sensor thread cleaner<br/>i.e.: (J-43897-18)<br/>(J-43897-12)</p>                                        | <p>Reconditions the exhaust system threads before installing a new oxygen sensor. Use with anti-seize lubricant shown below.<br/><b>a: 18 mm diameter with pitch 1.5 mm for Zirconia Oxygen Sensor</b><br/><b>b: 12 mm diameter with pitch 1.25 mm for Titania Oxygen Sensor</b></p> | <p>EC</p> <p>C</p>         |
| <p>Anti-seize lubricant<br/>i.e.: (Permatex™<br/>133AR or equivalent<br/>meeting MIL specification MIL-A-907)</p>  | <p>Lubricates oxygen sensor thread cleaning tool when reconditioning exhaust system threads.</p>   | <p>D</p> <p>E</p> <p>F</p> |

G

H

I

J

K

L

M

N

O

P

# COMPONENT PARTS

< SYSTEM DESCRIPTION >

[VK56VD FOR MEXICO]

## SYSTEM DESCRIPTION

### COMPONENT PARTS

#### ENGINE CONTROL SYSTEM

#### ENGINE CONTROL SYSTEM : Component Parts Location

INFOID:000000007758092

#### ENGINE ROOM COMPARTMENT

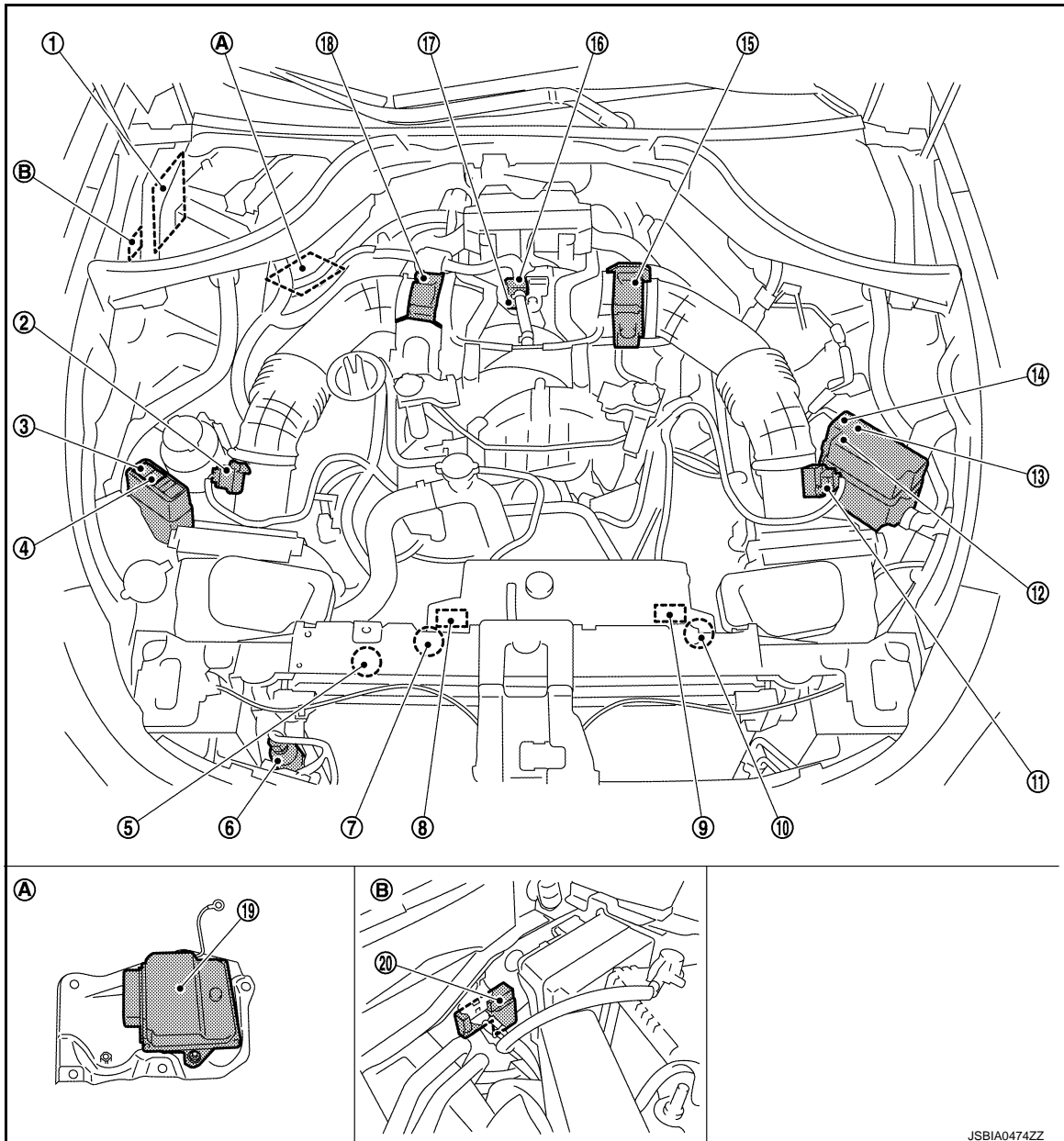

- |   |   |                                 |
|---|---|---------------------------------|
| 1. IPDM E/R<br><a href="#">PCS-5. "IPDM E/R : Component Parts Location"</a> | 2. Mass air flow sensor   | 3. Cooling fan relay 2          |
| 4. Injector relay 2   | 5. Power steering pressure sensor<br><a href="#">ST-76. "2WD : Exploded View" (2WD)</a><br><a href="#">ST-78. "AWD : Exploded View" (4WD)</a> | 6. Refrigerant pressure sensor  |
| 7. Cooling fan motor 2  | 8. Cooling fan control module 2   | 9. Cooling fan control module 1 |

# COMPONENT PARTS

< SYSTEM DESCRIPTION >

[VK56VD FOR MEXICO]

- |   |  |   |
|---|--|---|
| 10. Cooling fan motor 1                               | 11. Mass air flow sensor (with intake air temperature sensor) (bank 1) | 12. Injector relay 1                            |
| 13. VVEL actuator motor relay                         | 14. Cooling fan relay 1  | 15. Electric throttle control actuator (bank 1) |
| 16. EVAP canister purge volume control solenoid valve | 17. Manifold absolute pressure (MAP) sensor                            | 18. Electric throttle control actuator (bank 2) |
| 19. VVEL control module                               | 20. Battery current sensor (with battery temperature sensor)           |   |
| A. Under the battery tray (View with upside-down)     | B. Body side in battery case   |   |

## ENGINE COMPARTMENT

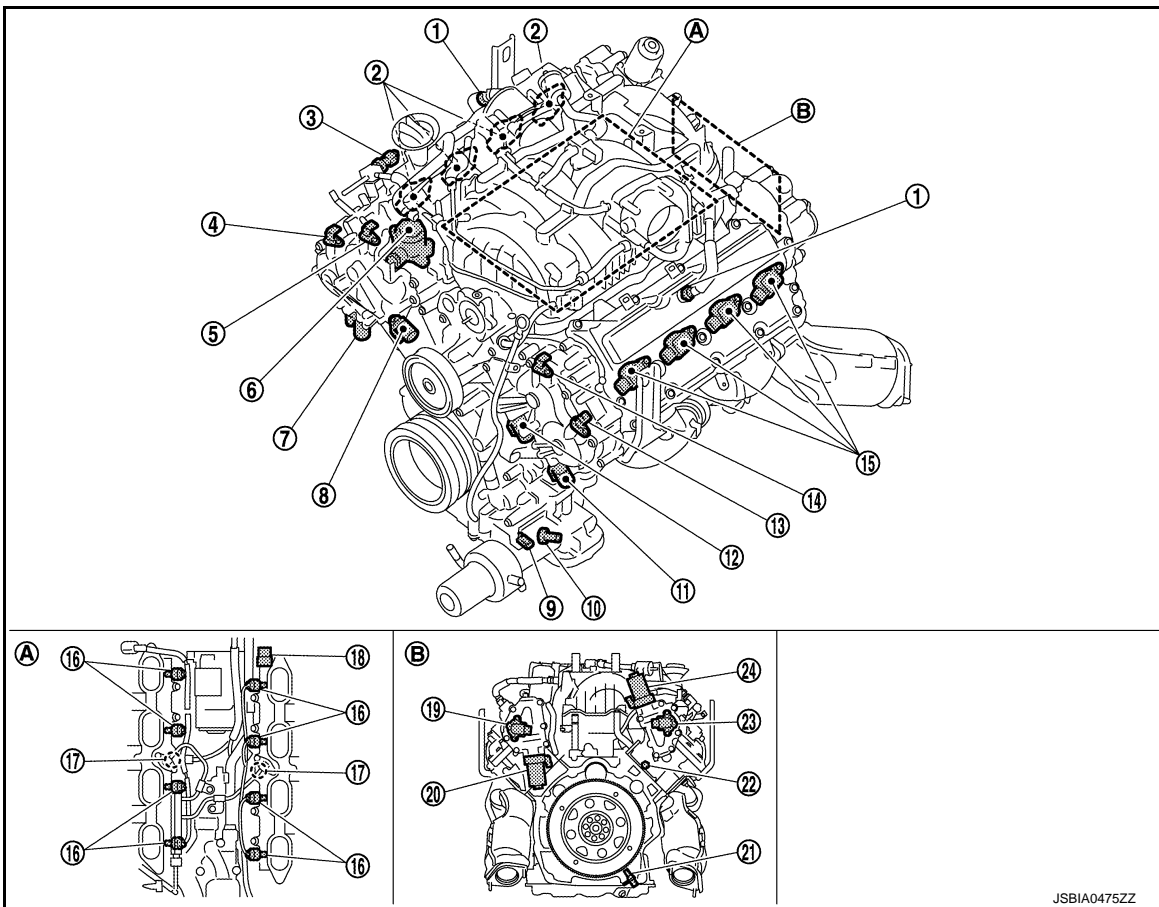

- |   |  |   |
|---|--|---|
| 1. Positive crankcase ventilation (PCV) valve             | 2. Ignition coil (with power transistor) and spark plug (bank 2) | 3. Low fuel pressure sensor                                       |
| 4. Exhaust valve timing control position sensor (bank 2)  | 5. Camshaft position sensor (bank 2)                             | 6. High pressure fuel pump  |
| 7. Exhaust valve timing control solenoid valve (bank 2)   | 8. Intake valve timing control solenoid valve (bank 2)           | 9. Engine oil temperature sensor                                  |
| 10. Engine oil pressure sensor                            | 11. Exhaust valve timing control solenoid valve (bank 1)         | 12. Intake valve timing control solenoid valve (bank 1)           |
| 13. Exhaust valve timing control position sensor (bank 1) | 14. Camshaft position sensor (bank 1)                            | 15. Ignition coil (with power transistor) and spark plug (bank 1) |
| 16. Fuel injector   | 17. Knock sensor   | 18. Fuel rail pressure sensor                                     |
| 19. VVEL control shaft position sensor (bank 1)           | 20. VVEL actuator motor (bank 1)                                 | 21. Crankshaft position sensor                                    |

# COMPONENT PARTS

[VK56VD FOR MEXICO]

## < SYSTEM DESCRIPTION >

- |   |   |                                  |
|---|---|----------------------------------|
| 22. Engine coolant temperature sensor                               | 23. VVEL control shaft position sensor (bank 2) | 24. VVEL actuator motor (bank 2) |
| A. Top view of the engine<br>(View with intake manifold is removed) | B. Rear view of the engine                      |                                  |

## EXHAUST COMPARTMENT

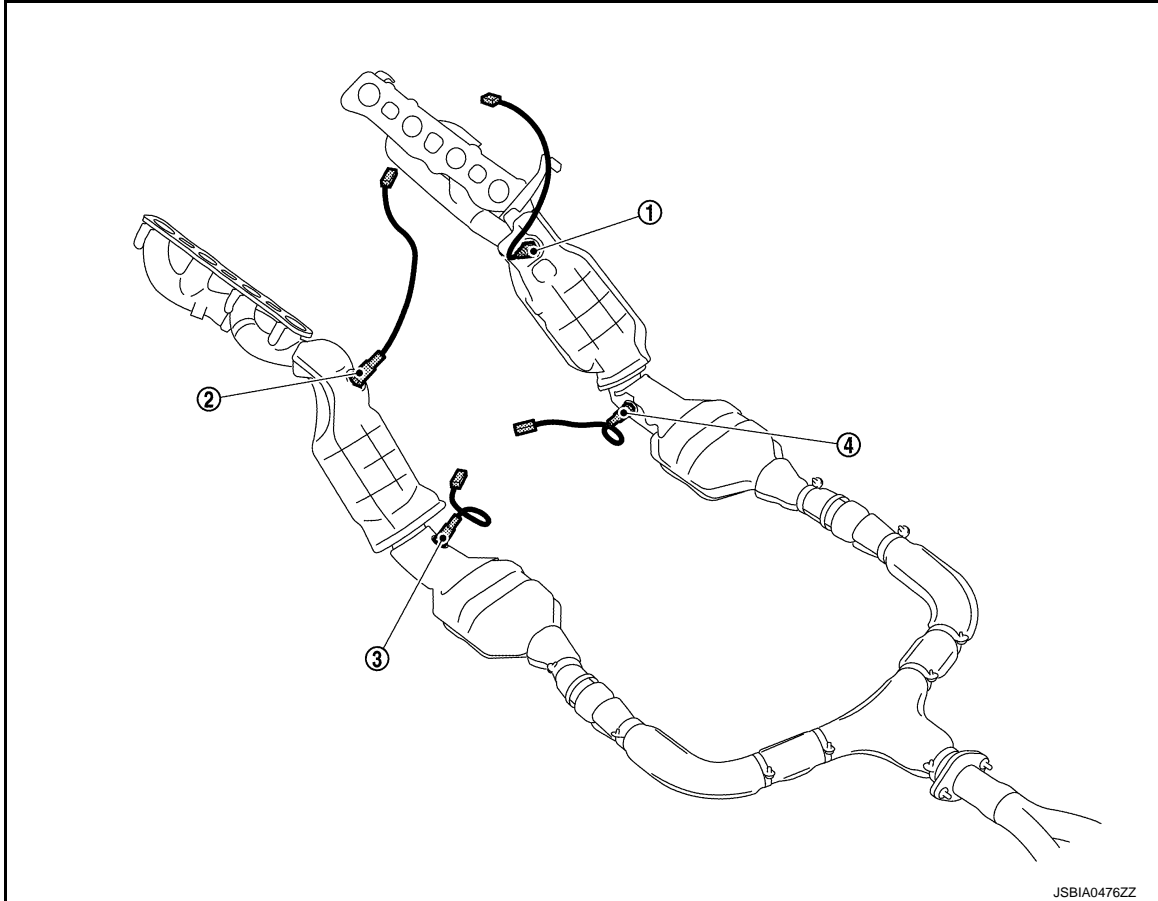

- |                                    |                          |                                    |
|------------------------------------|--------------------------|------------------------------------|
| 1. A/F sensor 1 (bank 2)           | 2. A/F sensor 1 (bank 1) | 3. Heated oxygen sensor 2 (bank 1) |
| 4. Heated oxygen sensor 2 (bank 2) |                          |                                    |

## BODY COMPARTMENT

# COMPONENT PARTS

< SYSTEM DESCRIPTION >

[VK56VD FOR MEXICO]

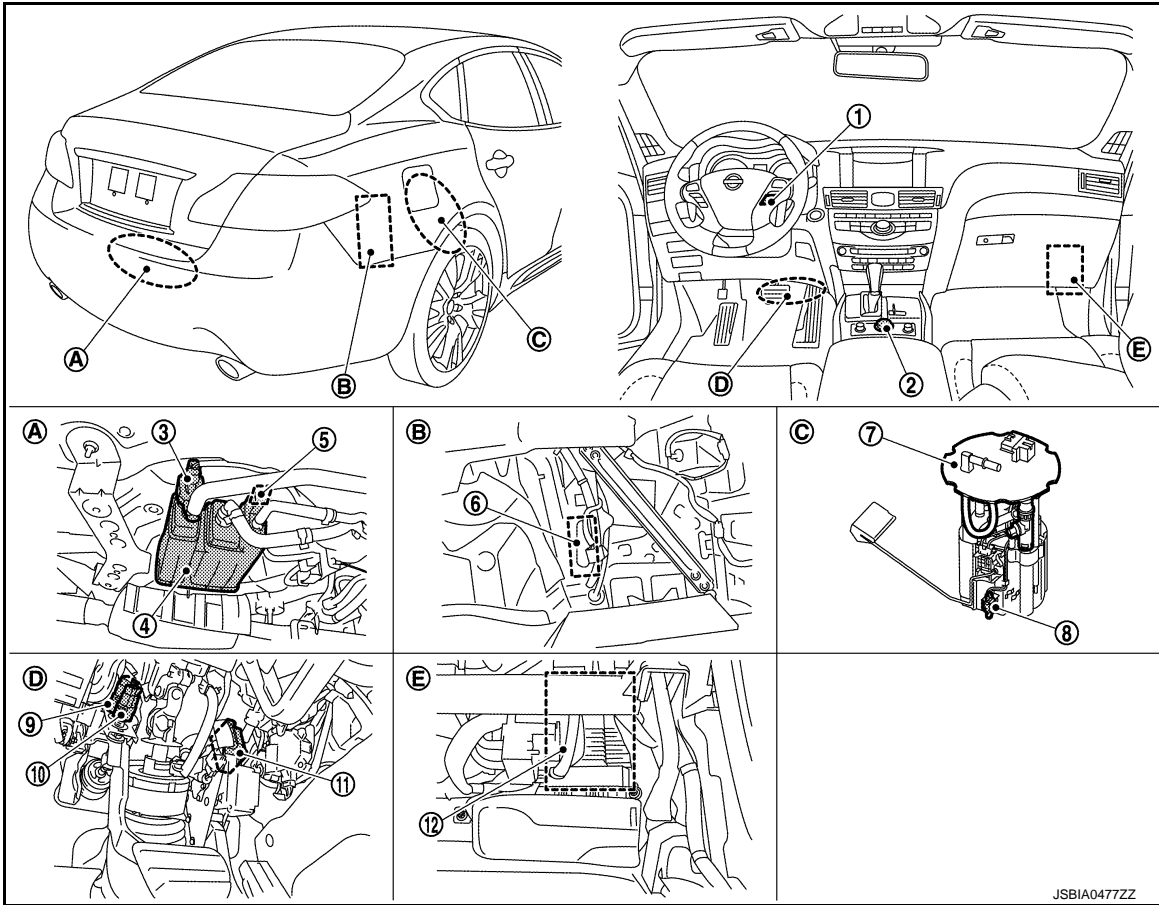

- |   |  |                                     |
|---|--|-------------------------------------|
| 1. ASCD steering switch<br>ICC steering switch                | 2. Drive mode select switch            | 3. EVAP canister vent control valve |
| 4. EVAP canister  | 5. EVAP control system pressure sensor | 6. Fuel pump control module (FPCM)  |
| 7. Fuel level sensor unit, fuel filter and fuel pump assembly | 8. Fuel tank temperature sensor        | 9. Stop lamp switch                 |
| 10. ICC brake switch  | 11. Accelerator pedal position sensor  | 12. ECM                             |

## ENGINE CONTROL SYSTEM : Component Description

INFOID:0000000007758093

| Component                           | Reference  |
|-------------------------------------|--|
| ECM                                 | <a href="#">EC-1572. "ECM"</a>   |
| Malfunction indicator lamp          | <a href="#">EC-1580. "Malfunction Indicator Lamp (MIL)"</a>                          |
| Ignition coil with power transistor | <a href="#">EC-1578. "Ignition Coil With Power Transistor"</a>                       |
| Accelerator pedal position sensor   | <a href="#">EC-1570. "Accelerator Pedal Position Sensor"</a>                         |
| Mass air flow sensor                | <a href="#">EC-1580. "Mass Air Flow Sensor (With Intake Air Temperature Sensor)"</a> |
| Intake air temperature sensor       |  |
| Electric throttle control actuator  | <a href="#">EC-1572. "Electric Throttle Control Actuator"</a>                        |
| Throttle control motor              |  |
| Throttle position sensor            |  |
| Crankshaft position sensor          | <a href="#">EC-1572. "Crankshaft Position Sensor"</a>                                |
| Camshaft position sensor            | <a href="#">EC-1571. "Camshaft Position Sensor"</a>                                  |
| Engine coolant temperature sensor   | <a href="#">EC-1573. "Engine Coolant Temperature Sensor"</a>                         |
| Engine oil pressure sensor          | <a href="#">EC-1574. "Engine Oil Pressure Sensor"</a>                                |

# COMPONENT PARTS

[VK56VD FOR MEXICO]

< SYSTEM DESCRIPTION >

| Component  | Reference   |
|--|---|
| Engine oil temperature sensor                            | <a href="#">EC-1574, "Engine Oil Temperature Sensor"</a>                            |
| Fuel injector  | <a href="#">EC-1576, "Fuel Injector"</a>  |
| Low pressure fuel pump                                   | <a href="#">EC-1579, "Low Pressure Fuel Pump"</a>                                   |
| Low fuel pressure sensor                                 | <a href="#">EC-1579, "Low Fuel Pressure Sensor"</a>                                 |
| Fuel pump control module (FPCM)                          | <a href="#">EC-1578, "Fuel Pump Control Module"</a>                                 |
| High pressure fuel pump                                  | <a href="#">EC-1577, "High Pressure Fuel Pump"</a>                                  |
| Fuel tank temperature sensor                             | <a href="#">EC-1576, "Fuel Tank Temperature Sensor"</a>                             |
| Fuel rail pressure sensor                                | <a href="#">EC-1578, "Fuel Rail Pressure Sensor"</a>                                |
| A/F sensor 1   | <a href="#">EC-1570, "Air Fuel Ratio (A/F) Sensor 1"</a>                            |
| A/F sensor 1 heater                                      |   |
| Heated oxygen sensor 2                                   | <a href="#">EC-1576, "Heated Oxygen Sensor 2"</a>                                   |
| Heated oxygen sensor 2 heater                            |   |
| Manifold absolute pressure sensor                        | <a href="#">EC-1580, "Manifold Absolute Pressure Sensor"</a>                        |
| Knock sensor   | <a href="#">EC-1579, "Knock Sensor"</a>   |
| Power steering pressure sensor                           | <a href="#">EC-1581, "Power Steering Pressure (PSP) Sensor"</a>                     |
| Cooling fan control module                               |   |
| Cooling fan motor  | <a href="#">EC-1572, "Cooling Fan"</a>  |
| Intake valve timing control solenoid valve               | <a href="#">EC-1579, "Intake Valve Timing Control Solenoid Valve"</a>               |
| Exhaust valve timing control position sensor             | <a href="#">EC-1575, "Exhaust Valve Timing Control Position Sensor"</a>             |
| Exhaust valve timing control solenoid valve              | <a href="#">EC-1576, "Exhaust Valve Timing Control Solenoid Valve"</a>              |
| VVEL control module                                      | <a href="#">EC-1581, "VVEL Control Module"</a>                                      |
| VVEL actuator motor relay                                | <a href="#">EC-1581, "VVEL Actuator Motor Relay"</a>                                |
| VVEL actuator motor                                      | <a href="#">EC-1581, "VVEL Actuator Motor"</a>                                      |
| VVEL control shaft position sensor                       | <a href="#">EC-1582, "VVEL Control Shaft Position Sensor"</a>                       |
| EVAP control system pressure sensor                      | <a href="#">EC-1575, "EVAP Control System Pressure Sensor"</a>                      |
| EVAP canister vent control valve                         | <a href="#">EC-1575, "EVAP Canister Vent Control Valve"</a>                         |
| EVAP canister purge volume control solenoid valve        | <a href="#">EC-1575, "EVAP Canister Purge Volume Control Solenoid Valve"</a>        |
| PCV valve  | <a href="#">EC-1583, "Positive Crankcase Ventilation"</a>                           |
| Brake booster pressure sensor (Vacuum sensor)            | <a href="#">BRC-12, "Vacuum Sensor"</a>   |
| Battery current sensor (with battery temperature sensor) | <a href="#">EC-1570, "Battery Current Sensor (With Battery Temperature Sensor)"</a> |
| Refrigerant pressure sensor                              | <a href="#">EC-1581, "Refrigerant Pressure Sensor"</a>                              |
| Stop lamp switch   | <a href="#">EC-1581, "Stop Lamp Switch"</a>   |
| Information display                                      | <a href="#">EC-1578, "Information Display"</a>                                      |
| ICC steering switch                                      | <a href="#">EC-1578, "ICC Steering Switch"</a>                                      |
| ICC brake switch   | <a href="#">EC-1578, "ICC Brake Switch"</a>   |

## Infiniti Drive Mode Selector



# COMPONENT PARTS

< SYSTEM DESCRIPTION >

[VK56VD FOR MEXICO]

## Infiniti Drive Mode Selector : Component Parts Location

INFOID:000000007758094

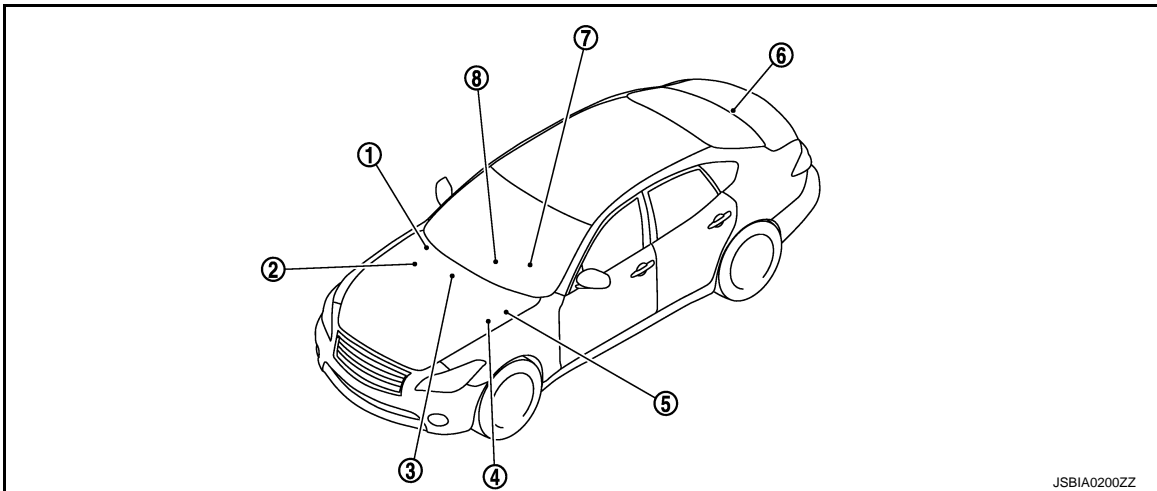

- |  |   |   |
|--|---|---|
| <p>1. A/C auto amp.<br/>Refer to <a href="#">HAC-7. "AUTOMATIC AIR CONDITIONING SYSTEM (WITH FOREST AIR) : Component Parts Location"</a> (WITH FOREST AIR).<br/>Refer to <a href="#">HAC-10. "AUTOMATIC AIR CONDITIONING SYSTEM (WITHOUT FOREST AIR) : Component Parts Location"</a> (WITHOUT FOREST AIR).</p> | <p>2. ECM<br/>Refer to <a href="#">EC-1564. "ENGINE CONTROL SYSTEM : Component Parts Location"</a>.</p> | <p>3. AV control unit<br/>Refer to <a href="#">AV-10. "Component Parts Location"</a> (BASE AUDIO WITHOUT NAVIGATION).<br/>Refer to <a href="#">AV-127. "Component Parts Location"</a> (BOSE AUDIO WITH NAVIGATION).</p> |
| <p>4. Accelerator pedal actuator</p>   | <p>5. Combination meter<br/>(Vehicle information display, and ECO drive indicator)</p>                  | <p>6. ADAS control unit<br/><a href="#">DAS-14. "Component Parts Location"</a>.</p>   |
| <p>7. TCM<br/><a href="#">TM-10. "A/T CONTROL SYSTEM : Component Parts Location"</a>.</p>  | <p>8. Drive mode select switch</p>  |   |

## Infiniti Drive Mode Selector : Component Description

INFOID:000000007758095

| Part name                | Description   |
|--------------------------|---|
| Drive mode select switch | Transmits an ON/OFF state signal of STANDARD, SPORT, ECO, or SNOW mode to the A/C auto amp.   |
| A/C auto amp.            | Transmits an input signal (ON/OFF state of each mode) received from the drive mode select switch to the TCM, combination meter and ADAS control unit via CAN communication.   |
| AV control unit          | Transmits an ECO pedal* reaction force setting signal (Standard/Soft/OFF) to ECM via CAN communication. This signal determines reaction force of the accelerator pedal.   |
| TCM                      | Transmits a state of a mode received from the A/C auto amp. to ECM.   |
| ECM                      | <ul style="list-style-type: none"> <li>Receives a ECO mode signal from TCM and controls throttle angle characteristics and torque.</li> <li>Determines reaction force in accordance with the accelerator pedal operation when in ECO mode and transmits an ECO pedal* reaction force control signal to the ADAS control unit. When receiving the ECO pedal* reaction force setting signal (Standard/Soft/OFF) from the AV control unit, ECM updates ECO pedal* reaction force. Furthermore, ECM sends back the received signal to the AV control unit for confirmation.</li> <li>Controls the ECO drive indicator when in ECO mode. The ECO drive indicator turns ON or blinks (with ECO pedal*) according to accelerator pedal operation.</li> </ul> |
| Combination meter        | <ul style="list-style-type: none"> <li>Indicates a mode state on the vehicle information display, based on a mode state signal received from the A/C auto amp.</li> <li>Turns ON or blinks (with ECO pedal*) the ECO drive indicator according to a request from ECM when in ECO mode.</li> </ul>   |

# COMPONENT PARTS

< SYSTEM DESCRIPTION >

[VK56VD FOR MEXICO]

| Part name                  | Description   |
|----------------------------|---|
| ADAS control unit          | Controls accelerator pedal reaction force of the accelerator pedal actuator when in ECO mode, based on an ECO pedal* reaction force control signal received from ECM. |
| Accelerator pedal actuator | Applies reaction force to the accelerator pedal when in ECO mode, based on an accelerator pedal reaction force control signal received from the ADAS control unit.    |

\*: ECO pedal control is only for vehicles with intelligent pedal (distance control assist).

## Accelerator Pedal Position Sensor

INFOID:000000007758096

The accelerator pedal position sensor is installed on the accelerator pedal assembly. The sensor detects the accelerator position and sends a signal to the ECM.

Accelerator pedal position sensor has two sensors. These sensors are a kind of potentiometer which transform the accelerator pedal position into output voltage, and emit the voltage signals to the ECM. The ECM judges the current opening angle of the accelerator pedal from these signals and controls the throttle control motor based on these signals.

Idle position of the accelerator pedal is determined by the ECM receiving the signal from the accelerator pedal position sensor. The ECM uses this signal for engine operations such as fuel cut.

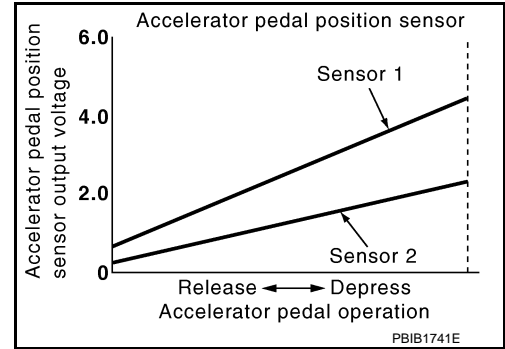

## Air Fuel Ratio (A/F) Sensor 1

INFOID:000000007758097

### DESCRIPTION

The sensor element of the A/F sensor 1 is composed an electrode layer, which transports ions. It has a heater in the element.

The sensor is capable of precise measurement  $\lambda = 1$ , but also in the lean and rich range. Together with its control electronics, the sensor outputs a clear, continuous signal throughout a wide  $\lambda$  range.

The exhaust gas components diffuse through the diffusion layer at the sensor cell. An electrode layer is applied voltage, and this current relative oxygen density in lean. Also this current relative hydrocarbon density in rich.

Therefore, the A/F sensor 1 is able to indicate air fuel ratio by this electrode layer of current. In addition, a heater is integrated in the sensor to ensure the required operating temperature of approximately 760°C (1,400°F).

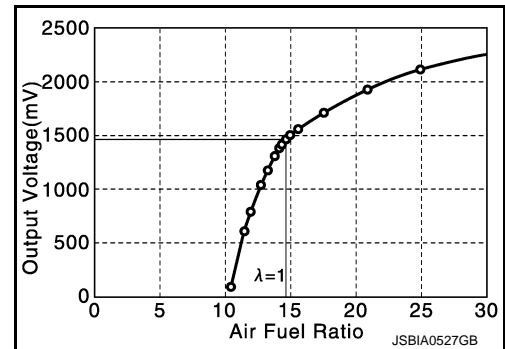

### A/F SENSOR 1 HEATER

A/F sensor 1 heater is integrated in the sensor.

The ECM performs ON/OFF duty control of the A/F sensor 1 heater corresponding to the engine operating condition to keep the temperature of A/F sensor 1 element within the specified range.

## Battery Current Sensor (With Battery Temperature Sensor)

INFOID:000000007758100

### OUTLINE

# COMPONENT PARTS

## < SYSTEM DESCRIPTION >

[VK56VD FOR MEXICO]

The power generation voltage variable control enables fuel consumption to be decreased by reducing the engine load which is caused by the power generation of the generator.

Based on sensor signals, ECM judges whether or not the power generation voltage variable control is performed. When performing the power generation voltage variable control, ECM calculates the target power generation voltage based on the sensor signal. And ECM sends the calculated value as the power generation command value to IPDM E/R. For the details of the power generation voltage variable control, refer to [CHG-8. "POWER GENERATION VOLTAGE VARIABLE CONTROL SYSTEM : System Description"](#).

### CAUTION:

**Never connect the electrical component or the ground wire directly to the battery terminal. The connection causes the malfunction of the power generation voltage variable control, and then the battery discharge may occur.**

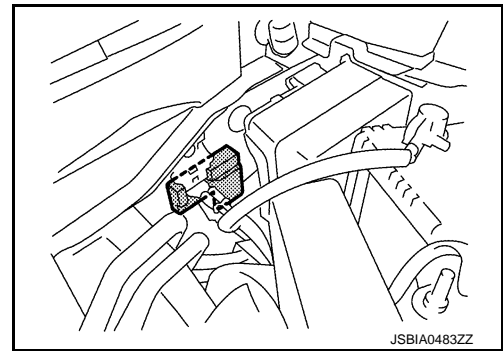

## BATTERY CURRENT SENSOR

The battery current sensor is installed to the battery negative cable. The sensor measures the charging/discharging current of the battery.

## BATTERY TEMPERATURE SENSOR

Battery temperature sensor is integrated in battery current sensor. The sensor measures temperature around the battery. The electrical resistance of the thermistor decreases as temperature increases.

### <Reference data>

| Temperature [°C (°F)] | Voltage* (V) | Resistance (kΩ) |
|-----------------------|--------------|-----------------|
| 25 (77)               | 3.333        | 1.9 - 2.1       |
| 90 (194)              | 0.969        | 0.222 - 0.258   |

\*: These data are reference values and are measured between battery temperature sensor signal terminal and sensor ground.

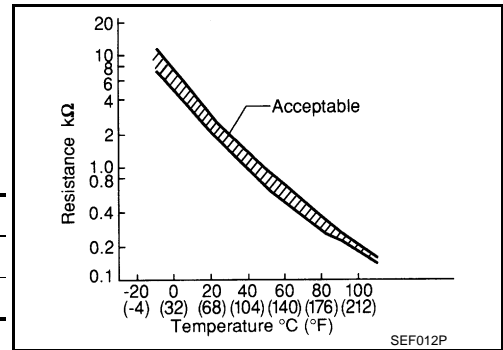

## Camshaft Position Sensor

INFOID:000000007758101

The camshaft position sensor senses the protrusion of the signal plate installed to the camshaft (INT) front end to identify a particular cylinder. The camshaft position sensor senses the piston position.

When the crankshaft position sensor system becomes inoperative, the camshaft position sensor provides various controls of engine parts instead, utilizing timing of cylinder identification signals.

The sensor consists of a permanent magnet and Hall IC.

When engine is running, the high and low parts of the teeth cause the gap with the sensor to change.

The changing gap causes the magnetic field near the sensor to change.

Due to the changing magnetic field, the voltage from the sensor changes.

ECM receives the signals as shown in the figure.

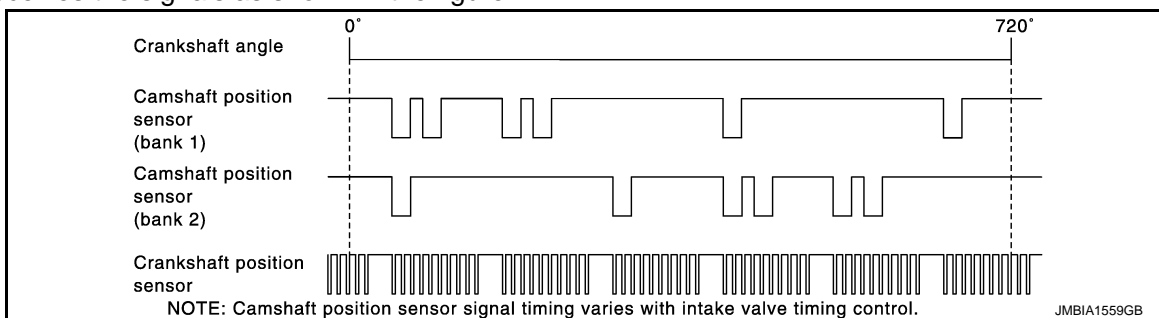
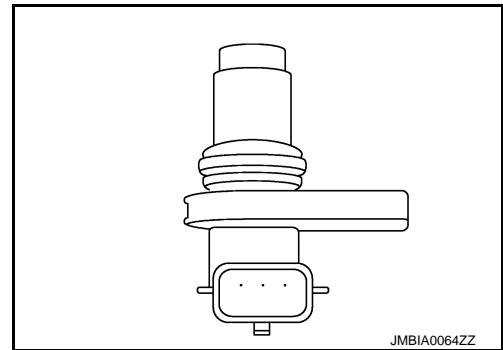

## Cooling Fan

INFOID:000000007758102

### COOLING FAN CONTROL MODULE

Cooling fan control module receives ON/OFF pulse duty signal from IPDM E/R. Corresponding to this ON/OFF pulse duty signal, cooling fan control module sends cooling fan motor operating voltage to cooling fan motor. The revolution speed of cooling fan motor is controlled by duty cycle of the voltage.

### COOLING FAN MOTOR

Cooling fan motor receives cooling fan motor operating voltage from cooling fan control module. The revolution speed of cooling fan motor is controlled by duty cycle of the voltage.

## Crankshaft Position Sensor

INFOID:000000007758103

The crankshaft position sensor is located on the cylinder block facing the gear teeth (cogs) of the signal plate. It detects the fluctuation of the engine revolution.

The sensor consists of a permanent magnet and Hall IC.

When the engine is running, the high and low parts of the teeth cause the gap with the sensor to change.

The changing gap causes the magnetic field near the sensor to change.

Due to the changing magnetic field, the voltage from the sensor changes.

The ECM receives the voltage signal and detects the fluctuation of the engine revolution.

ECM receives the signals as shown in the figure.

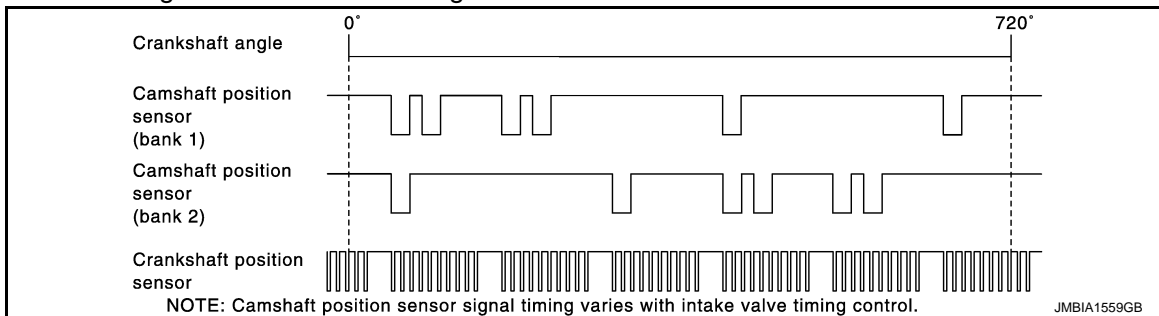
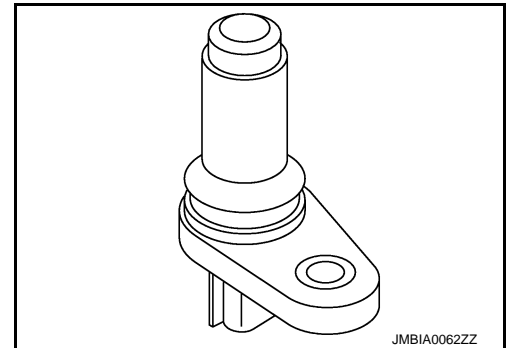

## ECM

INFOID:000000007758104

- ECM (Engine Control Module) controls the engine.
- The ECM consists of a microcomputer and connectors for transmitting/receiving signals and for supplying power. Furthermore, the ECM is equipped with an injector driver unit and actuates the fuel injector at a high voltage (approximately 70 V at the maximum).
- ECM is equipped with ECM temperature sensors. If ECM is overheated, ECM controls output torque to prevent damage to itself.
- Battery voltage is supplied to the ECM even when the ignition switch is turned OFF for the ECM memory function of the DTC memory, the air-fuel ratio feedback compensation value memory, the idle air volume learning value memory, etc.

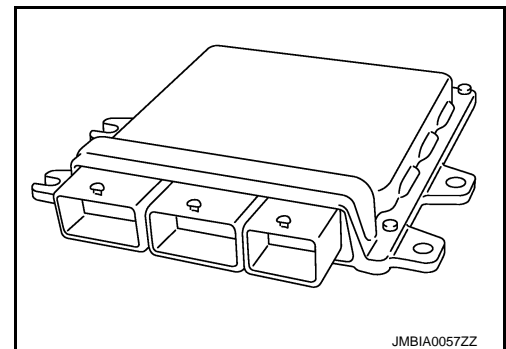

## Electric Throttle Control Actuator

INFOID:000000007758105

### OUTLINE

# COMPONENT PARTS

< SYSTEM DESCRIPTION >

[VK56VD FOR MEXICO]

Electric throttle control actuator consists of throttle body, throttle valve, throttle control motor and throttle position sensor.

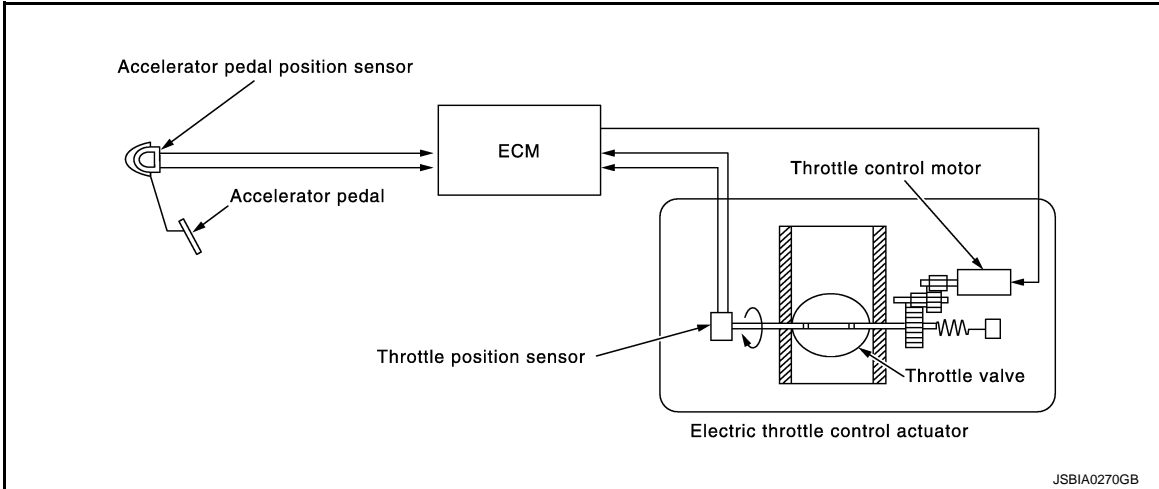

## THROTTLE CONTROL MOTOR

The throttle control motor is operated by the ECM and it opens and closes the throttle valve. The current opening angle of the throttle valve is detected by the throttle position sensor. The throttle position sensor provides feedback to the ECM, when opens/closes the throttle valve in response to driving conditions via the throttle control motor.

## THROTTLE POSITION SENSOR

The throttle position sensor responds to the throttle valve movement. The throttle position sensor has two sensors. These sensors are a kind of potentiometer which transform the throttle valve position into output voltage, and emit the voltage signal to the ECM. The ECM judges the current opening angle of the throttle valve from these signals and controls the throttle valve opening angle in response to driving conditions via the throttle control motor.

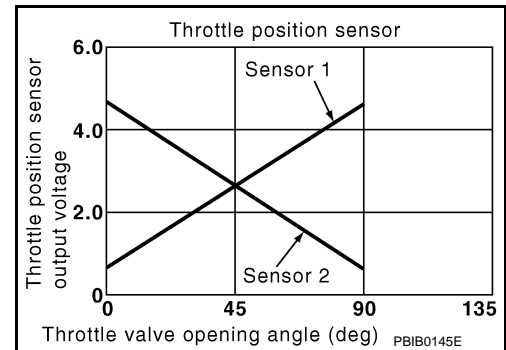

## Engine Coolant Temperature Sensor

INFOID:000000007758106

The engine coolant temperature sensor is used to detect the engine coolant temperature. The sensor modifies a voltage signal from the ECM. The modified signal returns to the ECM as the engine coolant temperature input. The sensor uses a thermistor which is sensitive to the change in temperature. The electrical resistance of the thermistor decreases as temperature increases.

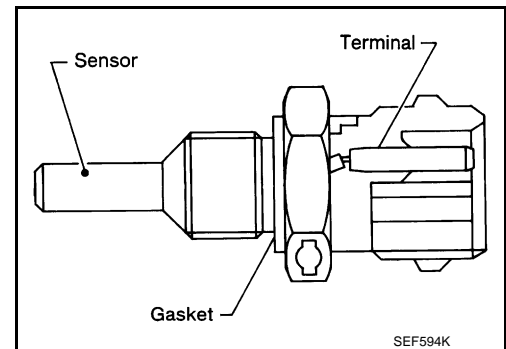

# COMPONENT PARTS

< SYSTEM DESCRIPTION >

[VK56VD FOR MEXICO]

## <Reference data>

| Engine coolant temperature<br>[°C (°F)] | Voltage* (V) | Resistance (kΩ) |
|---|--------------|-----------------|
| -10 (14)                                | 4.4          | 7.0 - 11.4      |
| 20 (68)                                 | 3.5          | 2.1 - 2.9       |
| 50 (122)                                | 2.2          | 0.68 - 1.00     |
| 90 (194)                                | 0.9          | 0.236 - 0.260   |

\*: These data are reference values and are measured between ECM terminals.

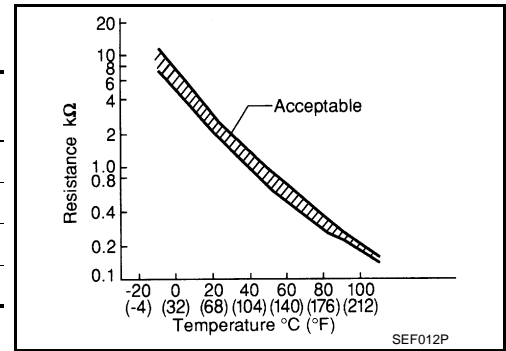

## Engine Oil Pressure Sensor

INFOID:000000007758107

The engine oil pressure (EOP) sensor detects engine oil pressure and transmits a voltage signal to the ECM.

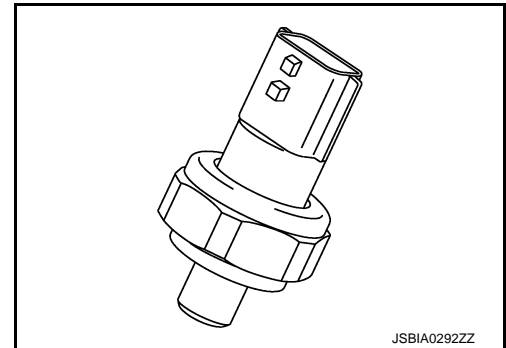

## Engine Oil Temperature Sensor

INFOID:000000007758108

The engine oil temperature sensor is used to detect the engine oil temperature. The sensor modifies a voltage signal from the ECM. The modified signal returns to the ECM as the engine oil temperature input. The sensor uses a thermistor which is sensitive to the change in temperature. The electrical resistance of the thermistor decreases as temperature increases.

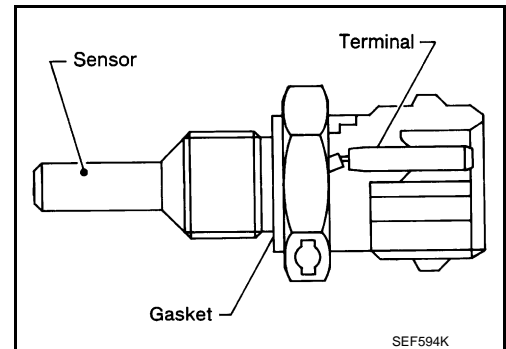

## <Reference data>

| Engine oil temperature<br>[°C (°F)] | Voltage* (V) | Resistance (kΩ) |
|-------------------------------------|--------------|-----------------|
| -10 (14)                            | 4.4          | 7.0 - 11.4      |
| 20 (68)                             | 3.5          | 2.1 - 2.9       |
| 50 (122)                            | 2.2          | 0.68 - 1.00     |
| 90 (194)                            | 0.9          | 0.236 - 0.260   |
| 110 (230)                           | 0.6          | 0.143 - 0.153   |

\*: These data are reference values and are measured between ECM terminals.

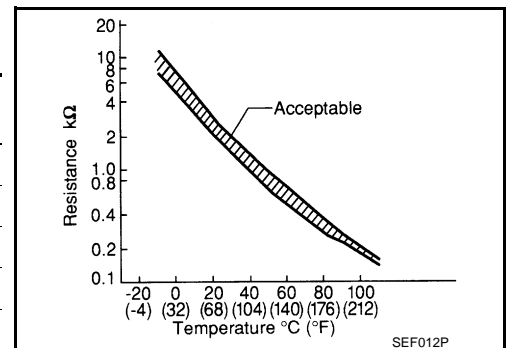

## EVAP Control System Pressure Sensor

INFOID:000000007758109

The EVAP control system pressure sensor detects pressure in the purge line. The sensor output voltage to the ECM increases as pressure increases.

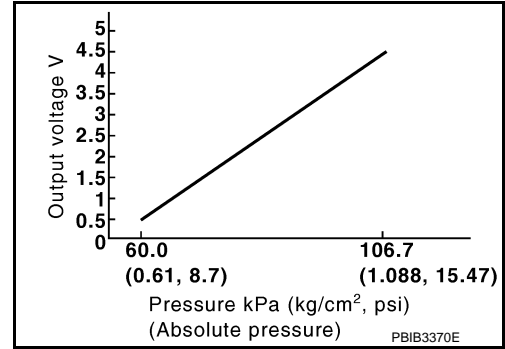

## EVAP Canister Vent Control Valve

INFOID:000000007758110

The EVAP canister vent control valve is located on the EVAP canister and is used to seal the canister vent.

This solenoid valve responds to signals from the ECM. When the ECM sends an ON signal, the coil in the solenoid valve is energized. A plunger will then move to seal the canister vent. The ability to seal the vent is necessary for the on board diagnosis of other evaporative emission control system components.

This solenoid valve is used only for diagnosis, and usually remains opened.

When the vent is closed, under normal purge conditions, the evaporative emission control system is depressurized and allows "EVAP Control System" diagnosis.

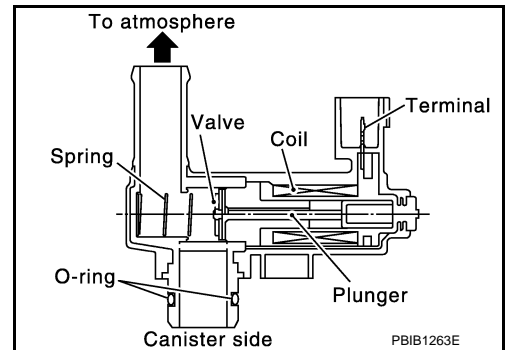

## EVAP Canister Purge Volume Control Solenoid Valve

INFOID:000000007758111

The EVAP canister purge volume control solenoid valve is used to control the flow rate of fuel vapor from the EVAP canister. The EVAP canister purge volume control solenoid valve is moved by ON/OFF pulses from the ECM. The longer the ON pulse, the greater the amount of fuel vapor that will flow through the valve.

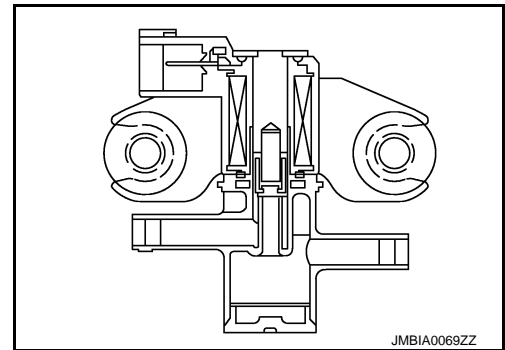

## Exhaust Valve Timing Control Position Sensor

INFOID:000000007758112

Exhaust valve timing control position sensor detects the protrusion of the signal plate installed to the exhaust camshaft front end.

This sensor signal is used for sensing a position of the exhaust camshaft.

This sensor uses a Hall IC.

Based on the position of the exhaust camshaft, ECM controls exhaust valve timing control solenoid valve to optimize the shut/open timing of exhaust valve for the driving condition.

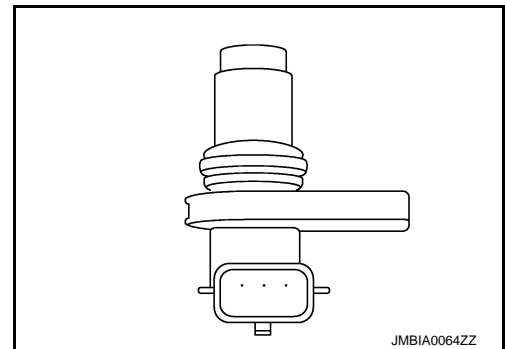

# COMPONENT PARTS

< SYSTEM DESCRIPTION >

[VK56VD FOR MEXICO]

## Exhaust Valve Timing Control Solenoid Valve

INFOID:000000007758113

Exhaust valve timing control solenoid valve is activated by ON/OFF pulse duty (ratio) signals from the ECM.

The exhaust valve timing control solenoid valve changes the oil amount and direction of flow through exhaust valve timing control unit or stops oil flow.

The longer pulse width retards valve angle.

The shorter pulse width advances valve angle.

When ON and OFF pulse widths become equal, the solenoid valve stops oil pressure flow to fix the exhaust valve angle at the control position.

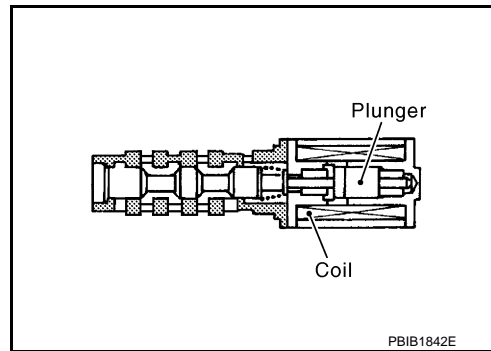

INFOID:000000007758114

## Fuel Injector

For the fuel injector, a high pressure fuel injector is used and this enables a high-pressure fuel injection at a high voltage within a short time. The ECM is equipped with an injector driver unit and actuates the fuel injector at a high voltage (approximately 65 V at the maximum).

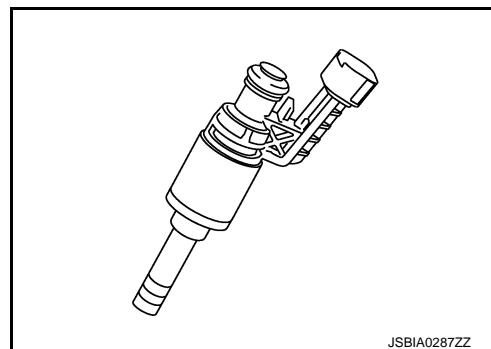

INFOID:000000007758115

## Fuel Tank Temperature Sensor

The fuel tank temperature sensor is used to detect the fuel temperature inside the fuel tank. The sensor modifies a voltage signal from the ECM. The modified signal returns to the ECM as the fuel temperature input. The sensor uses a thermistor which is sensitive to the change in temperature. The electrical resistance of the thermistor decreases as temperature increases.

### <Reference data>

| Fuel temperature [°C (°F)] | Voltage* (V) | Resistance (kΩ) |
|----------------------------|--------------|-----------------|
| 20 (68)                    | 3.5          | 2.3 - 2.7       |
| 50 (122)                   | 2.2          | 0.79 - 0.90     |

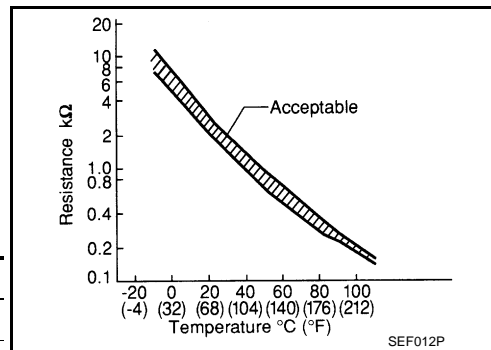

\*: These data are reference values and are measured between ECM terminals.

## Heated Oxygen Sensor 2

INFOID:000000007758116

### DESCRIPTION

The heated oxygen sensor 2, after three way catalyst (manifold), monitors the oxygen level in the exhaust gas on each bank.

Even if switching characteristics of the air fuel ratio (A/F) sensor 1 are shifted, the air fuel ratio is controlled to stoichiometric, by the signal from the heated oxygen sensor 2.

This sensor is made of ceramic zirconia. The zirconia generates voltage from approximately 1 V in richer conditions to 0 V in leaner conditions.

Under normal conditions the heated oxygen sensor 2 is not used for engine control operation.

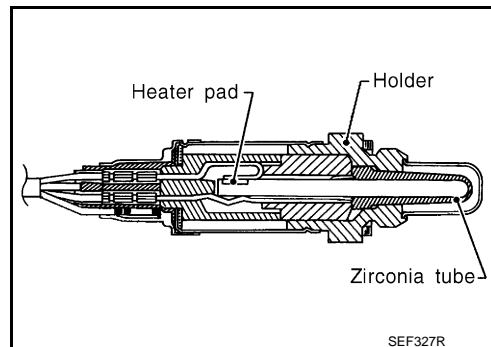

### HEATED OXYGEN SENSOR 2 HEATER



# COMPONENT PARTS

< SYSTEM DESCRIPTION >

[VK56VD FOR MEXICO]

Heated oxygen sensor 2 heater is integrated in the sensor.

The ECM performs ON/OFF control of the heated oxygen sensor 2 heater corresponding to the engine speed, amount of intake air and engine coolant temperature.

| Engine speed   | Heated oxygen sensor 2 heater |
|--|-------------------------------|
| Above 3,600 rpm  | OFF                           |
| Below 3,600 rpm after the following conditions are met. <ul style="list-style-type: none"> <li>• Engine: After warming up</li> <li>• Keeping the engine speed between 3,500 and 4,000 rpm for 1 minute and at idle for 1 minute under no load</li> </ul> | ON                            |

## High Pressure Fuel Pump

INFOID:000000007758117

The high pressure fuel pump is installed at the front of the engine bank 2 side and activated by the camshaft. ECM controls the high pressure fuel pump control solenoid valve built into the high pressure fuel pump and adjusts the amount of discharge by changing the suction timing of the low pressure fuel.

### Operating Description

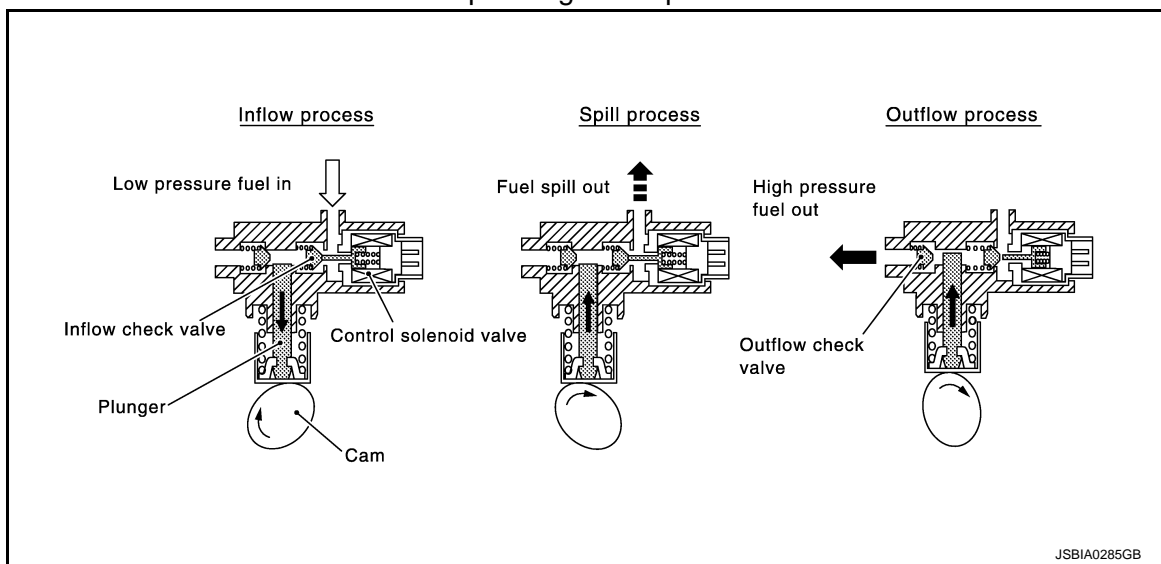

### Operating Chart

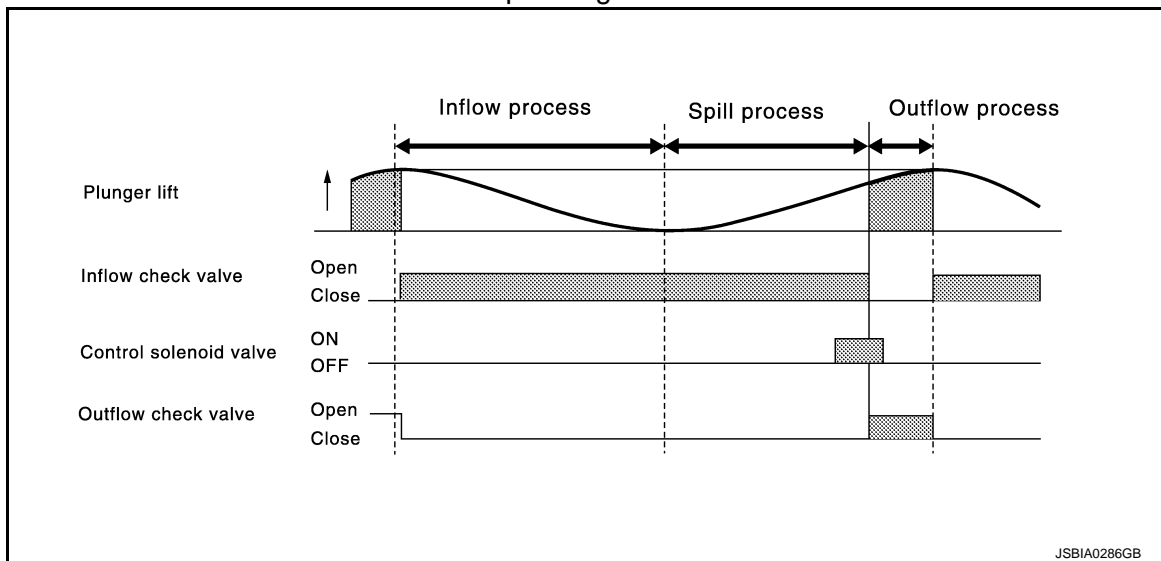

## Fuel Pump Control Module

INFOID:000000007758118

The fuel pump control module (FPCM) controls the discharging volume of the fuel pump by transmitting the FPCM control signals (Low/Mid/High) depending on driving conditions.

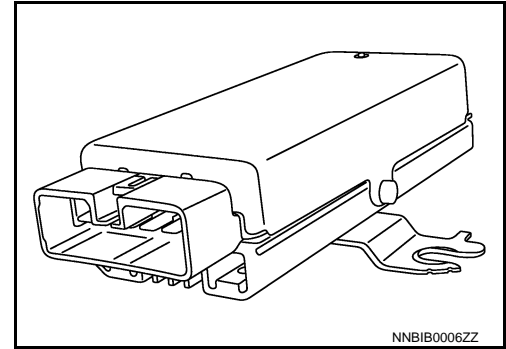

## Fuel Rail Pressure Sensor

INFOID:000000007758119

The fuel rail pressure (FRP) sensor is placed to the fuel rail and measures fuel pressure in the fuel rail. The sensor transmits voltage signal to the ECM. As the pressure increases, the voltage rises. The ECM controls the fuel pressure in the fuel rail by operating high pressure fuel pump. The ECM uses the signal from fuel rail pressure sensor as a feedback signal.

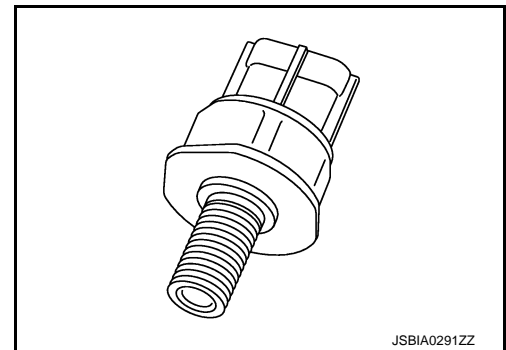

## ICC Brake Switch

INFOID:000000007758120

When the brake pedal is depressed, ICC brake switch is turned OFF and stop lamp switch is turned ON. ECM detects the state of the brake pedal by those two types of input (ON/OFF signal).

## ICC Steering Switch

INFOID:000000007758121

ICC steering switch has variant values of electrical resistance for each button. ECM reads voltage variation of switch, and determines which button is operated.

## Ignition Coil With Power Transistor

INFOID:000000007758122

The ignition signal from the ECM is sent to and amplified by the power transistor. The power transistor turns ON and OFF the ignition coil primary circuit. This ON/OFF operation induces the proper high voltage in the coil secondary circuit.

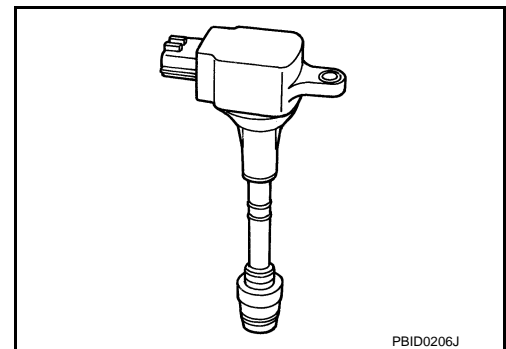

## Information Display

INFOID:000000007758123

The operation mode of the ASCD is indicated on the information display in the combination meter. When turning ON the MAIN switch of the ASCD steering switch, the CRUISE indicator turns ON, CRUISE is indicated on the information display and the operation mode turns to standby mode. When turning ON the SET/COAST switch while the vehicle is driven at the ASCD setting condition speed range, the SET indicator turns ON and the set speed is indicated on the information display. When the canceling conditions come into effect, CANCEL is indicated on the information display.

## Intake Valve Timing Control Solenoid Valve

INFOID:000000007758124

Intake valve timing control solenoid valve is activated by ON/OFF pulse duty (ratio) signals from the ECM.

The intake valve timing control solenoid valve changes the oil amount and direction of flow through intake valve timing control unit or stops oil flow.

The longer pulse width advances valve angle.

The shorter pulse width retards valve angle.

When ON and OFF pulse widths become equal, the solenoid valve stops oil pressure flow to fix the intake valve angle at the control position.

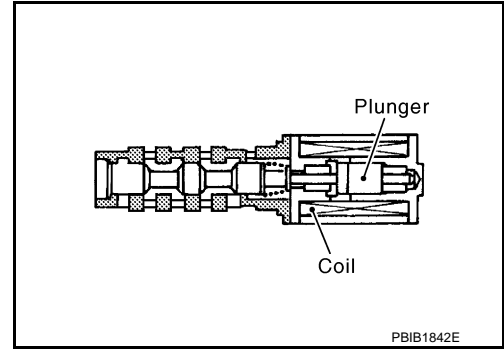

## Knock Sensor

INFOID:000000007758125

The knock sensor is attached to the cylinder block. It senses engine knocking using a piezoelectric element. A knocking vibration from the cylinder block is sensed as vibrational pressure. This pressure is converted into a voltage signal and sent to the ECM.

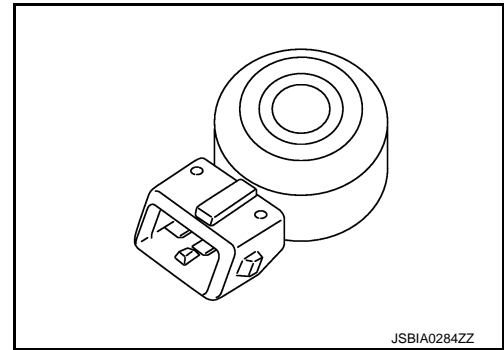

## Low Fuel Pressure Sensor

INFOID:000000007758126

The low fuel pressure sensor is installed to low fuel pressure piping and measures the low fuel pressure. The sensor transmits voltage signal to the ECM. As the pressure increases, the voltage rises.

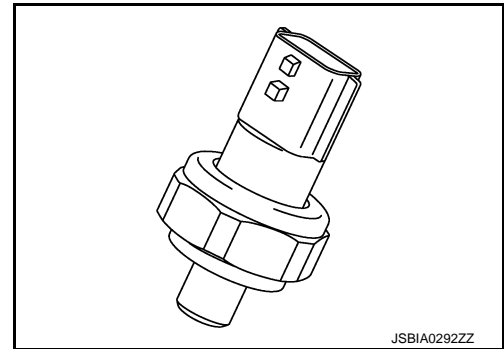

## Low Pressure Fuel Pump

INFOID:000000007758127

The low pressure fuel pump is integrated with a fuel pressure regulator and a fuel filter. This pump is build into the fuel tank.

ECM controls the low pressure fuel pump via FPCM.

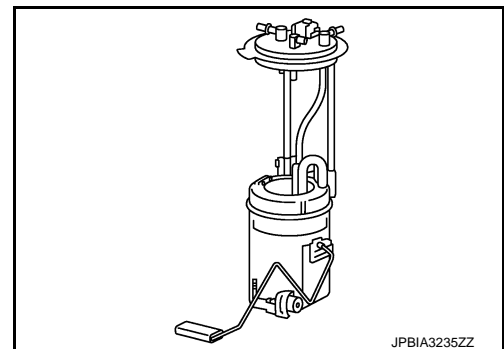

A  
EC  
C  
D  
E  
F  
G  
H  
I  
J  
K  
L  
M  
N  
O  
P

# COMPONENT PARTS

< SYSTEM DESCRIPTION >

[VK56VD FOR MEXICO]

## Malfunction Indicator Lamp (MIL)

INFOID:000000007758128

The Malfunction Indicator Lamp (MIL) is located on the combination meter.

The MIL will illuminate when the ignition switch is turned ON without the engine running. This is a bulb check.

When the engine is started, the MIL should turn off. If the MIL remains illuminated, the on board diagnostic system has detected an engine system malfunction.

For details, refer to [EC-1603. "Diagnosis Description"](#).

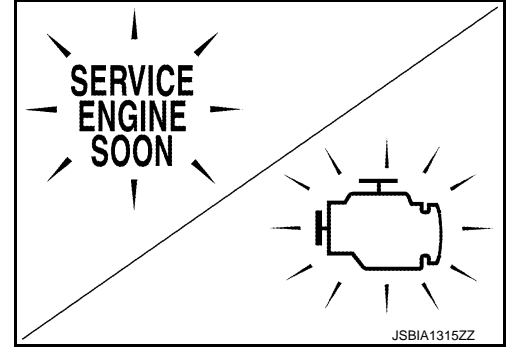

## Manifold Absolute Pressure Sensor

INFOID:000000007758129

The manifold absolute pressure (MAP) sensor is installed on the intake manifold collector. Detects intake manifold pressure, and transmits a voltage signal to the ECM.

The sensor uses a silicon diaphragm which is sensitive to the change in pressure. As the pressure increases, the voltage rises.

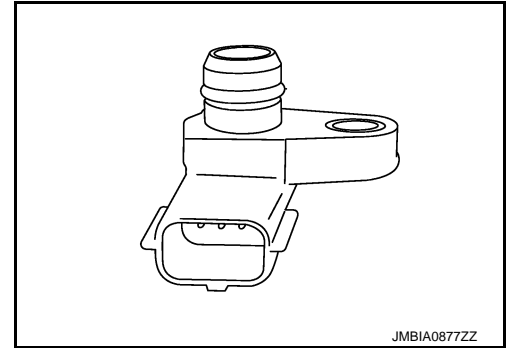

## Mass Air Flow Sensor (With Intake Air Temperature Sensor)

INFOID:000000007758130

### MASS AIR FLOW SENSOR

The mass air flow sensor (1) is placed in the stream of intake air. It measures the intake flow rate by measuring a part of the entire intake flow. The mass air flow sensor controls the temperature of the hot wire to a certain amount. The heat generated by the hot wire is reduced as the intake air flows around it. The greater air flow, the greater the heat loss.

Therefore, the electric current supplied to hot wire is changed to maintain the temperature of the hot wire as air flow increases. The ECM detects the air flow by means of this current change.

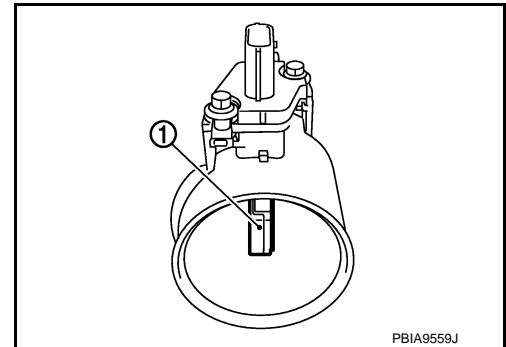

### INTAKE AIR TEMPERATURE SENSOR

The intake air temperature sensor is built-into the mass air flow sensor. The sensor detects intake air temperature and transmits a signal to the ECM.

The temperature sensing unit uses a thermistor which is sensitive to the change in temperature. Electrical resistance of the thermistor decreases in response to the rise in temperature.

#### <Reference data>

| Intake air temperature<br>[°C (°F)] | Voltage* (V) | Resistance (kΩ) |
|-------------------------------------|--------------|-----------------|
| 25 (77)                             | 3.3          | 1.94 - 2.06     |
| 80 (176)                            | 1.2          | 0.293 - 0.349   |

\*: These data are reference values and are measured between ECM terminals.

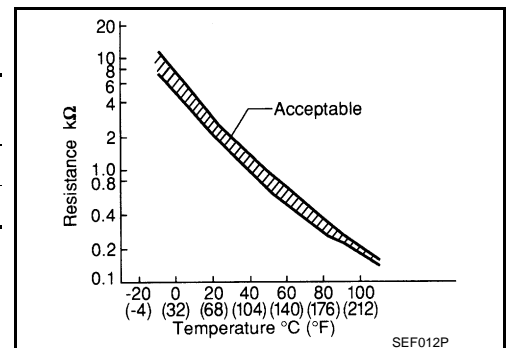

# COMPONENT PARTS

< SYSTEM DESCRIPTION >

[VK56VD FOR MEXICO]

## Power Steering Pressure (PSP) Sensor

INFOID:000000007758131

Power steering pressure (PSP) sensor is installed to the power steering high-pressure tube and detects a power steering load.

This sensor is a potentiometer which transforms the power steering load into output voltage, and emits the voltage signal to the ECM. The ECM controls the electric throttle control actuator and adjusts the throttle valve opening angle to increase the engine speed and adjusts the idle speed for the increased load.

## Refrigerant Pressure Sensor

INFOID:000000007758132

The refrigerant pressure sensor is installed at the condenser of the air conditioner system. The sensor uses an electrostatic volume pressure transducer to convert refrigerant pressure to voltage. The voltage signal is sent to ECM, and ECM controls cooling fan system.

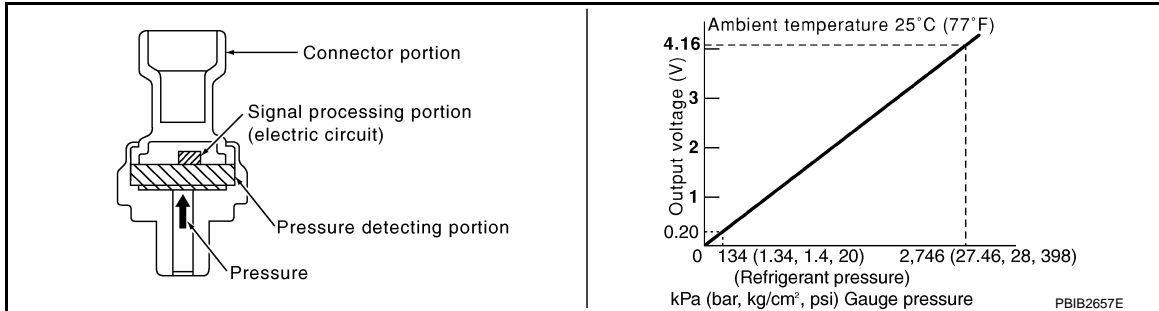

## Stop Lamp Switch

INFOID:000000007758133

Brake switch signal is applied to the ECM through the stop lamp switch when the brake pedal is depressed. This signal is used mainly to decrease the engine speed when the vehicle is being driven.

## VVEL Actuator Motor

INFOID:000000007758134

The VVEL actuator motor rotates the control shaft according to the control signal from the VVEL control module. The VVEL control module judges whether the VVEL actuator motor controls the angle properly by the VVEL control shaft position sensor signal.

## VVEL Actuator Motor Relay

INFOID:000000007758135

Power supply for the VVEL actuator motor is provided to the VVEL control module via VVEL actuator motor relay. VVEL actuator motor relay is ON/OFF controlled by the VVEL control module. In addition, when the VVEL actuator motor relay cannot be controlled by the VVEL control module for some reason, it ON/OFF controlled by ECM.

## VVEL Control Module

INFOID:000000007758136

The VVEL control module consists of a microcomputer and connectors for signal input and output and for power supply. The VVEL control module controls VVEL system.

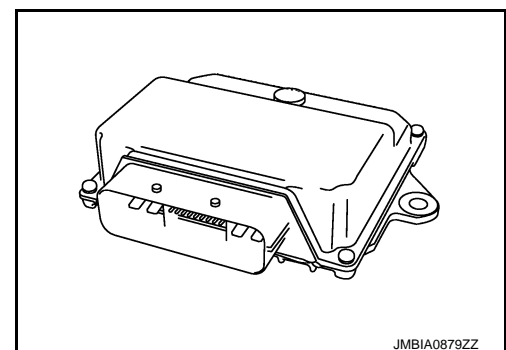

## COMPONENT PARTS

< SYSTEM DESCRIPTION >

[VK56VD FOR MEXICO]

### VVEL Control Shaft Position Sensor

INFOID:000000007758137

VVEL control shaft position sensor (1) is placed on VVEL actuator sub assembly and detects the control shaft position angle. A magnet is pressed into the arm on the edge of control shaft. The magnetic field changes as the magnet rotates together with the arm resulting in the output voltage change of the sensor. VVEL control module detects the actual position angle through the voltage change and sends the signal to ECM.

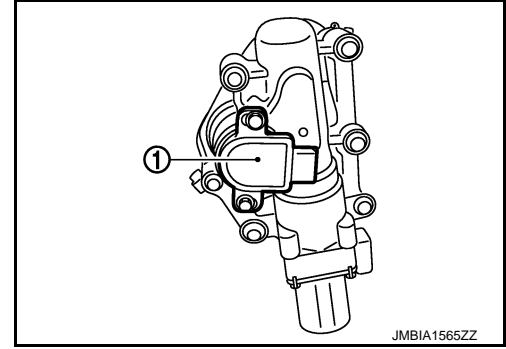

## STRUCTURE AND OPERATION

### Positive Crankcase Ventilation

INFOID:000000007758138

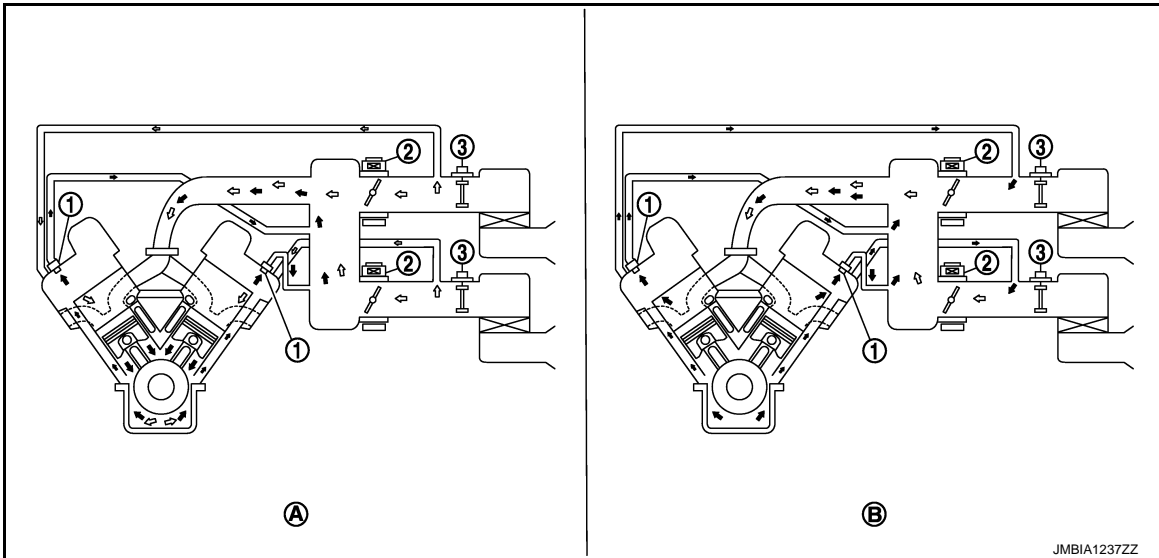

- |                     |                                       |                         |
|---------------------|---------------------------------------|-------------------------|
| 1. PCV valve        | 2. Electric throttle control actuator | 3. Mass air flow sensor |
| A. Normal condition | B. Hi-load condition                  |                         |

⇐: Fresh air

⇐: Blow-by air

This system returns blow-by gas to the intake manifold.

The positive crankcase ventilation (PCV) valve is provided to conduct crankcase blow-by gas to the intake manifold.

During partial throttle operation of the engine, the intake manifold sucks the blow-by gas through the PCV valve.

Normally, the capacity of the valve is sufficient to handle any blow-by and a small amount of ventilating air. The ventilating air is drawn from the air inlet tubes into the crankcase. In this process the air passes through the hose connecting air inlet tubes to rocker cover.

Under full-throttle condition, the manifold vacuum is insufficient to draw the blow-by flow through the valve. The flow goes through the hose connection in the reverse direction.

On vehicles with an excessively high blow-by, the valve does not meet the requirement. This is because some of the flow will go through the hose connection to the air inlet tubes under all conditions.

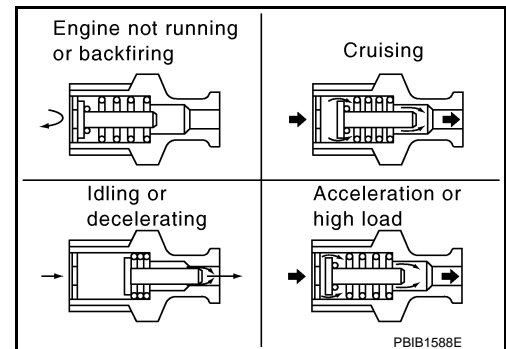

# STRUCTURE AND OPERATION

< SYSTEM DESCRIPTION >

[VK56VD FOR MEXICO]

## On Board Refueling Vapor Recovery (ORVR)

INFOID:000000007758139

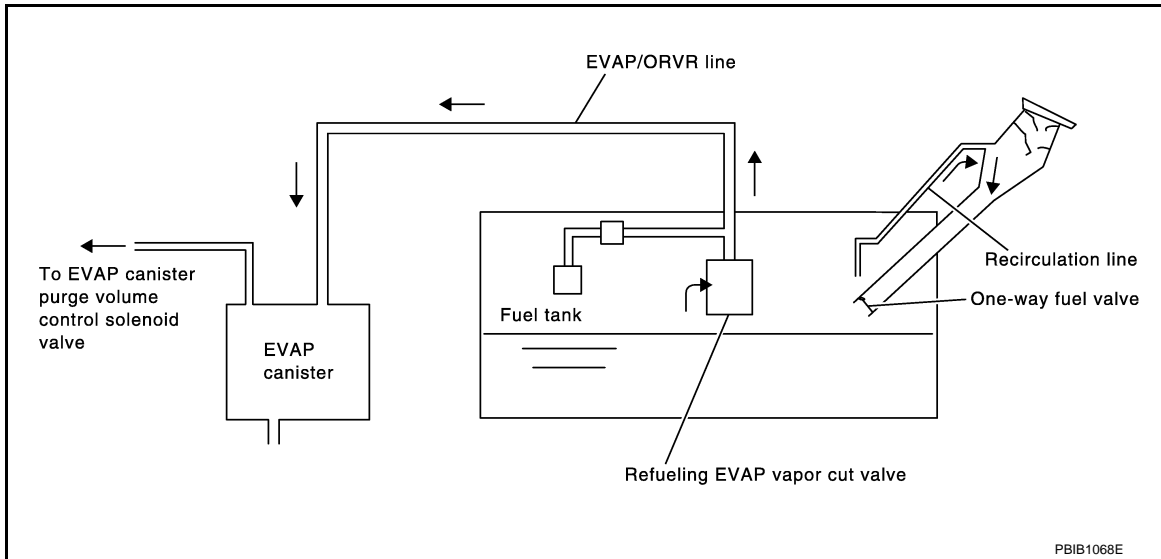

From the beginning of refueling, the air and vapor inside the fuel tank go through refueling EVAP vapor cut valve and EVAP/ORVR line to the EVAP canister. The vapor is absorbed by the EVAP canister and the air is released to the atmosphere.

When the refueling has reached the full level of the fuel tank, the refueling EVAP vapor cut valve is closed and refueling is stopped because of auto shut-off. The vapor which was absorbed by the EVAP canister is purged during driving.

### **WARNING:**

When conducting inspections below, be sure to observe the following:

- Put a “CAUTION: FLAMMABLE” sign in workshop.
- Never smoke while servicing fuel system. Keep open flames and sparks away from work area.
- Always furnish the workshop with a CO<sub>2</sub> fire extinguisher.

### **CAUTION:**

- Before removing fuel line parts, carry out the following procedures:
  - Put drained fuel in an explosion-proof container and put lid on securely.
  - Release fuel pressure from fuel line. Refer to [EC-1692. "Work Procedure"](#).
  - Disconnect battery ground cable.
- Always replace O-ring when the fuel gauge retainer is removed.
- Never kink or twist hose and tube when they are installed.
- Never tighten hose and clamps excessively to avoid damaging hoses.
- After installation, run engine and check for fuel leaks at connections.
- Never attempt to top off the fuel tank after the fuel pump nozzle shuts off automatically. Continued refueling may cause fuel overflow, resulting in fuel spray and possibly a fire.



SYSTEM  
ENGINE CONTROL SYSTEM  
ENGINE CONTROL SYSTEM : System Diagram

INFOID:000000007758140

A

EC

C

D

E

F

G

H

I

J

K

L

M

N

O

P

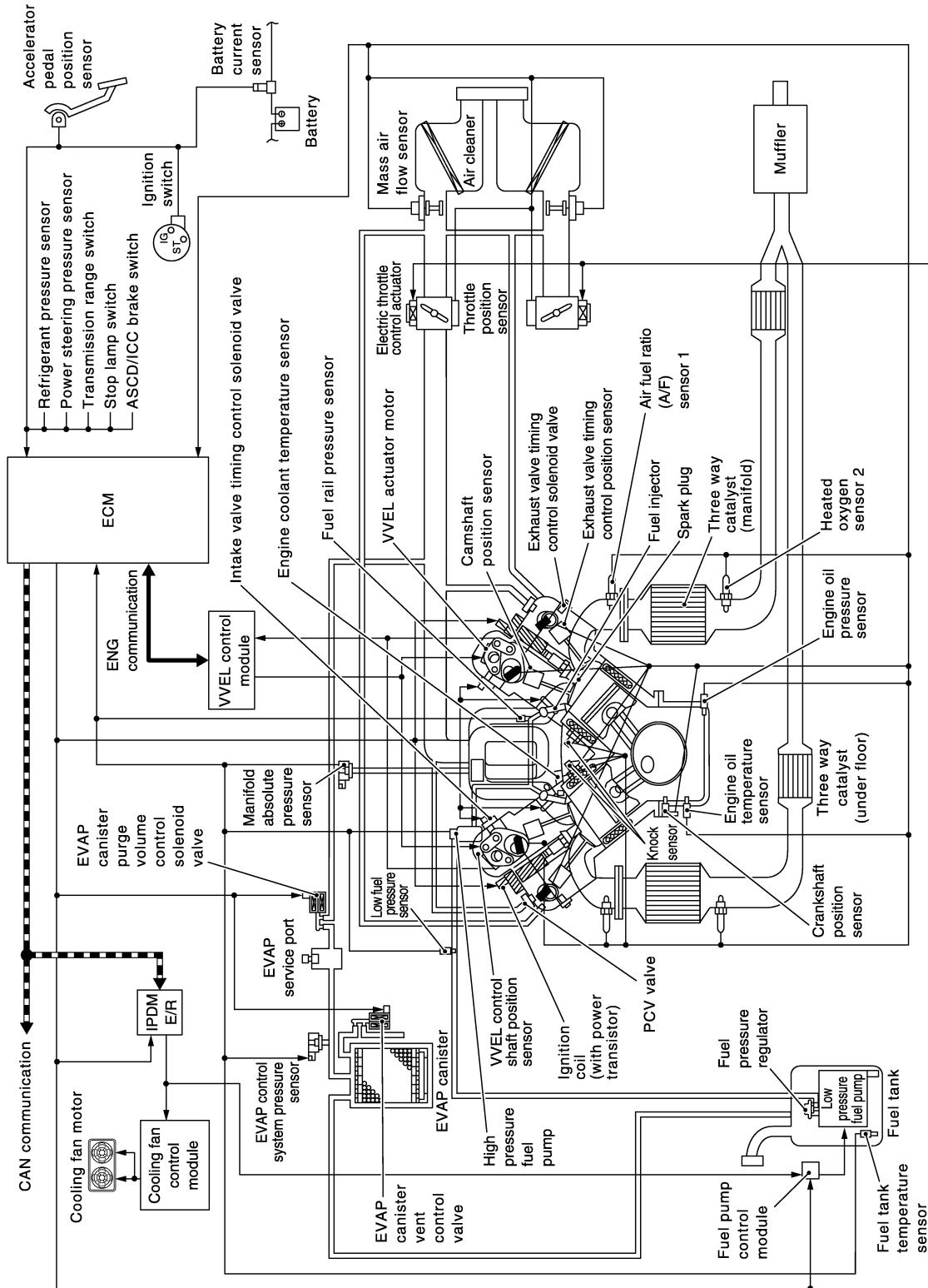

JSBIA0368GB

ENGINE CONTROL SYSTEM : System Description

INFOID:000000007758141

ECM performs various controls such as fuel injection control and ignition timing control.

# SYSTEM

< SYSTEM DESCRIPTION >

[VK56VD FOR MEXICO]

## DIRECT INJECTION GASOLINE SYSTEM

### DIRECT INJECTION GASOLINE SYSTEM : System Diagram

INFOID:000000007758142

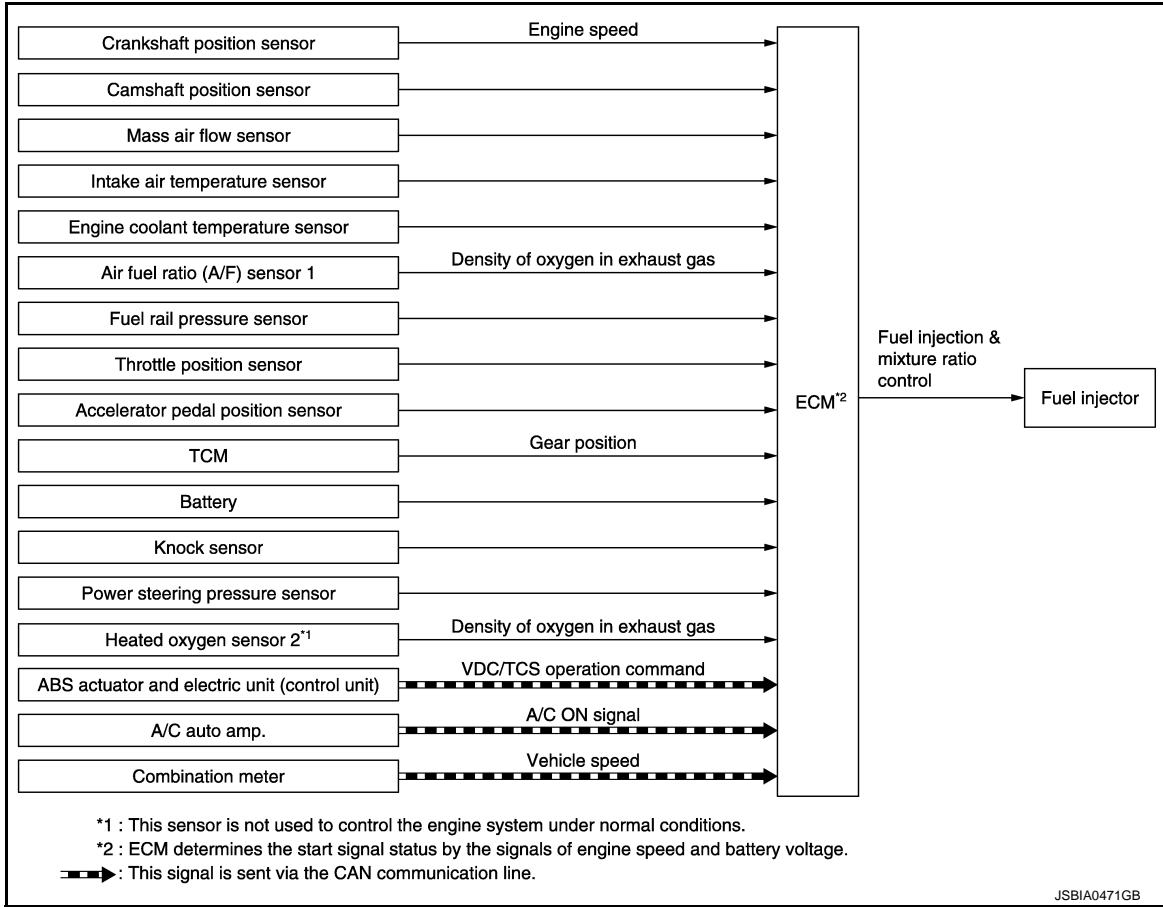

### DIRECT INJECTION GASOLINE SYSTEM : System Description

INFOID:000000007758143

#### INPUT/OUTPUT SIGNAL CHART

# SYSTEM

< SYSTEM DESCRIPTION >

[VK56VD FOR MEXICO]

| Sensor  | Input signal to ECM               | ECM function                           | Actuator      |    |
|---|-----------------------------------|--|---------------|----|
| Crankshaft position sensor                    | Engine speed*2                    | Fuel injection & mixture ratio control | Fuel injector | A  |
| Camshaft position sensor                      | Camshaft position                 |  |               | EC |
| Mass air flow sensor                          | Amount of intake air              |  |               |    |
| Intake air temperature sensor                 | Intake air temperature            |  |               |    |
| Engine coolant temperature sensor             | Engine coolant temperature        |  |               | C  |
| Air fuel ratio (A/F) sensor 1                 | Density of oxygen in exhaust gas  |  |               |    |
| Fuel rail pressure sensor                     | Fuel rail pressure                |  |               | D  |
| Throttle position sensor                      | Throttle position                 |  |               |    |
| Accelerator pedal position sensor             | Accelerator pedal position        |  |               |    |
| TCM   | Park/neutral position             |  |               | E  |
| Battery                                       | Battery voltage*2                 |  |               |    |
| Knock sensor                                  | Engine knocking condition         |  |               |    |
| Power steering pressure sensor                | Power steering operation          |  |               | F  |
| Heated oxygen sensor 2*1                      | Density of oxygen in exhaust gas  |  |               |    |
| ABS actuator and electric unit (control unit) | VDC/TCS operation command         |  |               | G  |
| A/C auto amp.                                 | A/C ON signal<br>Blower ON signal |  |               |    |
| Combination meter                             | Vehicle speed                     | H                                      |               |    |

\*1: This sensor is not used to control the engine system under normal conditions.

\*2: ECM determines the start signal status by the signals of engine speed and battery voltage.

## SYSTEM DESCRIPTION

The adoption of the direct fuel injection method enables more accurate adjustment of fuel injection quantity by injecting atomized high-pressure fuel directly into the cylinder. This method allows high-powered engine, low fuel consumption, and emissions-reduction.

The amount of fuel injected from the fuel injector is determined by the ECM. The ECM controls the length of time the valve remains open (injection pulse duration). The amount of fuel injected is a program value in the ECM memory. The program value is preset by engine operating conditions. These conditions are determined by input signals (for engine speed and intake air and fuel rail pressure) from the crankshaft position sensor, camshaft position sensor, mass air flow sensor and the fuel rail pressure sensor.

## VARIOUS FUEL INJECTION INCREASE/DECREASE COMPENSATION

In addition, the amount of fuel injected is compensated to improve engine performance under various operating conditions as listed below.

<Fuel increase>

- During warm-up
- When starting the engine
- During acceleration
- Hot-engine operation
- When selector lever position is changed from N to D
- High-load, high-speed operation

<Fuel decrease>

- During deceleration
- During high engine speed operation

## FUEL INJECTION CONTROL

### Stratified-charge Combustion

Stratified-charge combustion is a combustion method which enables extremely lean combustion by injecting fuel in the latter half of a compression process, collecting combustible air-fuel around the spark plug, and forming fuel-free airspace around the mixture.

Right after a start with the engine cold, the catalyst warm-up is accelerated by stratified-charge combustion.

### Homogeneous Combustion

Homogeneous combustion is a combustion method that fuel is injected during intake process so that combustion occurs in the entire combustion chamber, as is common with conventional methods.

As for a start except for starts with the engine cold, homogeneous combustion occurs.

### MIXTURE RATIO FEEDBACK CONTROL (CLOSED LOOP CONTROL)

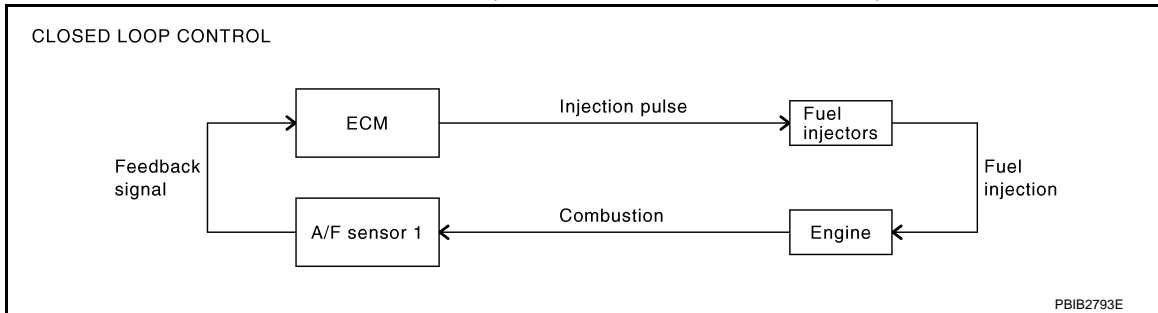

The mixture ratio feedback system provides the best air-fuel mixture ratio for driveability and emission control. The three way catalyst (manifold) can better reduce CO, HC and NO<sub>x</sub> emissions. This system uses A/F sensor 1 in the exhaust manifold to monitor whether the engine operation is rich or lean. The ECM adjusts the injection pulse width according to the sensor voltage signal. For more information about A/F sensor 1, refer to [EC-1570, "Air Fuel Ratio \(A/F\) Sensor 1"](#). This maintains the mixture ratio within the range of stoichiometric (ideal air-fuel mixture).

This stage is referred to as the closed loop control condition.

Heated oxygen sensor 2 is located downstream of the three way catalyst (manifold). Even if the switching characteristics of A/F sensor 1 shift, the air-fuel ratio is controlled to stoichiometric by the signal from heated oxygen sensor 2.

#### • Open Loop Control

The open loop system condition refers to when the ECM detects any of the following conditions. Feedback control stops in order to maintain stabilized fuel combustion.

- Deceleration and acceleration
- High-load, high-speed operation
- Malfunction of A/F sensor 1 or its circuit
- Insufficient activation of A/F sensor 1 at low engine coolant temperature
- High engine coolant temperature
- During warm-up
- After shifting from N to D
- When starting the engine

### MIXTURE RATIO SELF-LEARNING CONTROL

The mixture ratio feedback control system monitors the mixture ratio signal transmitted from A/F sensor 1. This feedback signal is then sent to the ECM. The ECM controls the basic mixture ratio as close to the theoretical mixture ratio as possible. However, the basic mixture ratio is not necessarily controlled as originally designed. Both manufacturing differences (i.e., mass air flow sensor hot wire) and characteristic changes during operation (i.e., fuel injector clogging) directly affect mixture ratio.

Accordingly, the difference between the basic and theoretical mixture ratios is monitored in this system. This is then computed in terms of "injection pulse duration" to automatically compensate for the difference between the two ratios.

"Fuel trim" refers to the feedback compensation value compared against the basic injection duration. Fuel trim includes "short-term fuel trim" and "long-term fuel trim".

"Short term fuel trim" is the short-term fuel compensation used to maintain the mixture ratio at its theoretical value. The signal from A/F sensor 1 indicates whether the mixture ratio is RICH or LEAN compared to the theoretical value. The signal then triggers a reduction in fuel volume if the mixture ratio is rich, and an increase in fuel volume if it is lean.

"Long-term fuel trim" is overall fuel compensation carried out over time to compensate for continual deviation of the "short-term fuel trim" from the central value. Continual deviation will occur due to individual engine differences, wear over time and changes in the usage environment.

### FUEL INJECTION TIMING

Sequential Direct Injection Gasoline System

# SYSTEM

## < SYSTEM DESCRIPTION >

[VK56VD FOR MEXICO]

Fuel is injected into each cylinder during each engine cycle according to the ignition order.

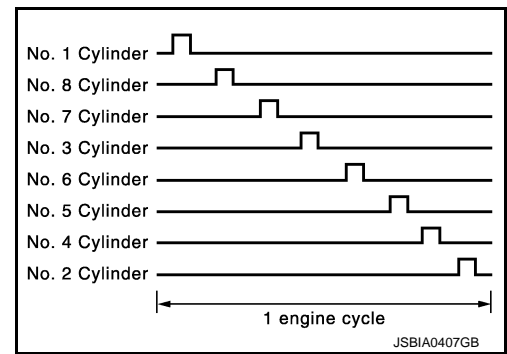

### STRATIFIED-CHARGE START CONTROL

The use of the stratified-charge combustion method enables emissions-reduction when starting the engine with engine coolant temperature between 5°C (41°F) and 40°C (104°F).

### FUEL SHUT-OFF

Fuel to each cylinder is shut-off during deceleration, operation of the engine at excessively high speed or operation of the vehicle at excessively high speed.

### FUEL PRESSURE CONTROL

#### FUEL PRESSURE CONTROL : System Diagram

INFOID:000000007758144

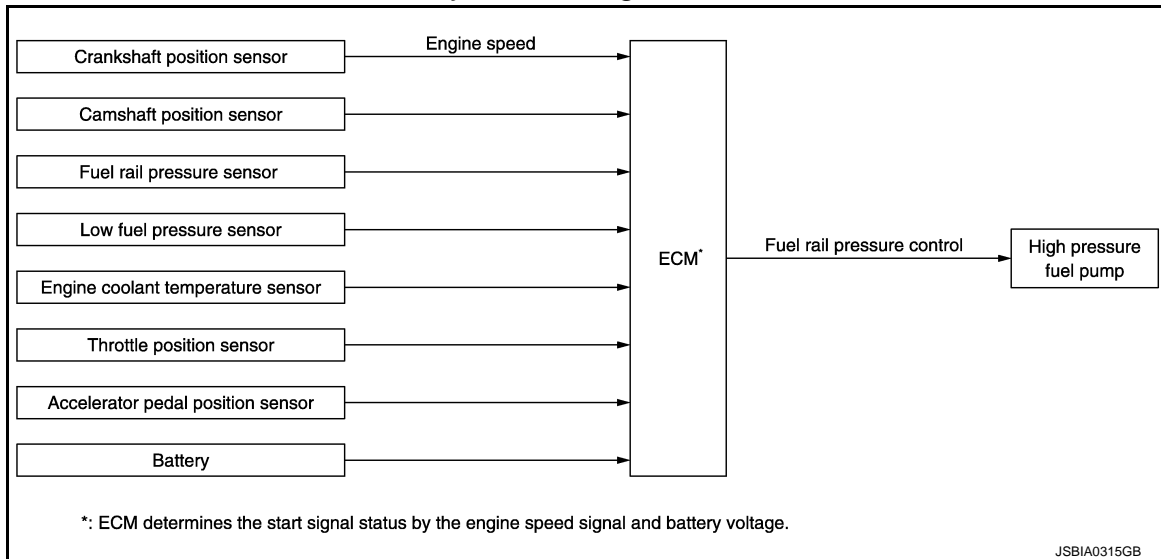

#### FUEL PRESSURE CONTROL : System Description

INFOID:000000007758145

#### INPUT/OUTPUT SIGNAL CHART

| Sensor                            | Input signal to ECM        | ECM function                           | Actuator      |
|-----------------------------------|----------------------------|--|---------------|
| Crankshaft position sensor        | Engine speed               | Fuel injection & mixture ratio control | Fuel injector |
| Camshaft position sensor          | Camshaft position          |  |               |
| Fuel rail pressure sensor         | Fuel rail pressure         |  |               |
| Low fuel pressure sensor          | Low fuel pressure          |  |               |
| Engine coolant temperature sensor | Engine coolant temperature |  |               |
| Throttle position sensor          | Throttle position          |  |               |
| Accelerator pedal position sensor | Accelerator pedal position |  |               |
| Battery                           | Battery voltage            |  |               |

# SYSTEM

< SYSTEM DESCRIPTION >

[VK56VD FOR MEXICO]

## SYSTEM DESCRIPTION

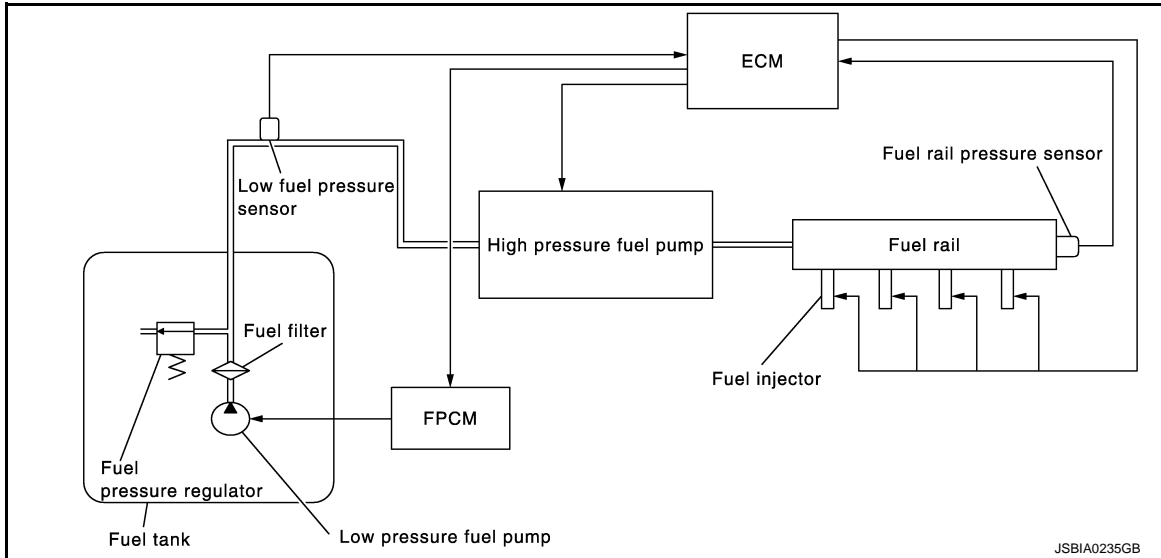

### Low fuel pressure control

- The low fuel pressure pump is controlled by the fuel pump control module (FPCM) and pumps fuel according to a driving condition. The pumped fuel passes through the fuel filter and is sent to the high pressure fuel pump. FPCM controls the low pressure fuel pump, according to a signal from ECM as shown in the table below.

| Conditions  | Amount of fuel flow | Supplied voltage               |
|---|---------------------|--------------------------------|
| After a lapse of 1 second after ignition ON   | OFF                 | 0 V                            |
| <ul style="list-style-type: none"> <li>For 1 second after ignition ON (engine coolant temperature is 5°C (41°F) or less, or 40°C (104°F) or more)</li> <li>For 1 second after turning ignition switch ON</li> <li>Engine is running under low load and low speed conditions</li> </ul>                              | Low                 | Approximately 8.5 V            |
| <ul style="list-style-type: none"> <li>For 1 second after ignition ON (engine coolant temperature is 5°C (41°F) or more, or 40°C (104°F) or less)</li> <li>Engine cranking</li> <li>Engine coolant temperature is below 10°C (50°F)</li> <li>Engine is running under high load and high speed conditions</li> </ul> | High                | Battery voltage<br>(11 – 14 V) |
| Except the above  | Mid                 | Approximately 10 V             |

- Low fuel pressure is adjusted by the fuel pressure regulator.

### High fuel pressure control

The high pressure fuel pump raises the pressure of the fuel sent from the low pressure fuel pump. Actuated by the camshaft, the high pressure fuel pump activates the high pressure fuel pump solenoid based on a signal received from ECM, and adjusts the amount of discharge by changing the timing of closing the inlet check valve to control fuel rail pressure.

## COOLING FAN CONTROL

# SYSTEM

< SYSTEM DESCRIPTION >

[VK56VD FOR MEXICO]

## COOLING FAN CONTROL : System Diagram

INFOID:000000007758146

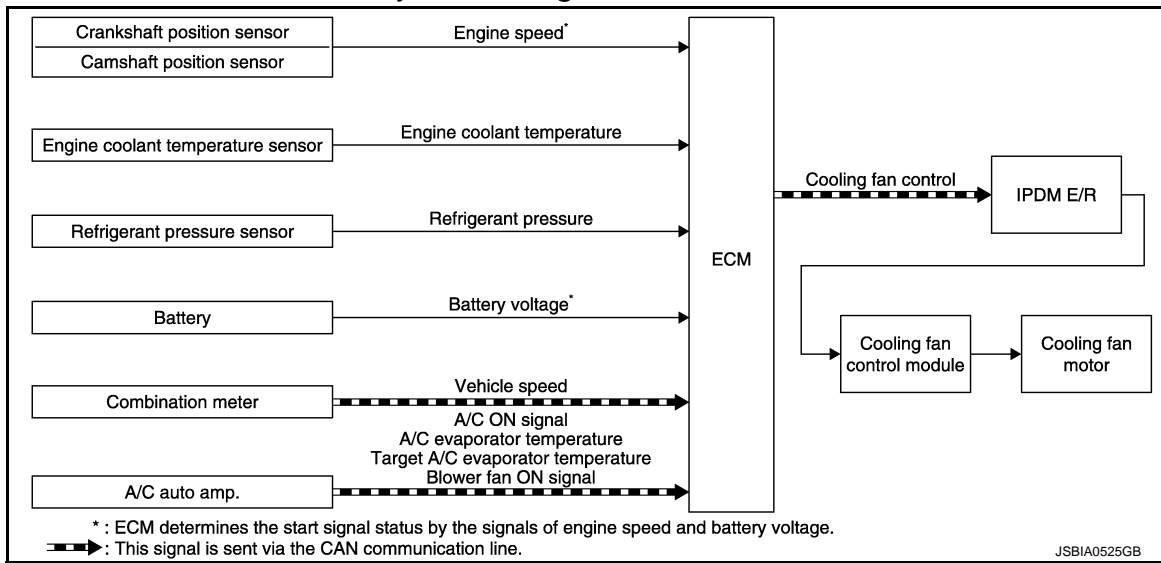

## COOLING FAN CONTROL : System Description

INFOID:000000007758147

### INPUT/OUTPUT SIGNAL CHART

| Sensor   | Input signal to ECM                             | ECM function        | Actuator  |
|--|---|---------------------|---|
| Crankshaft position sensor<br>Camshaft position sensor | Engine speed* <sup>1</sup>                      | Cooling fan control | IPDM E/R<br>↓<br>Cooling fan control module<br>↓<br>Cooling fan motor |
| Engine coolant temperature sensor                      | Engine coolant temperature                      |                     |   |
| Refrigerant pressure sensor                            | Refrigerant pressure                            |                     |   |
| Battery  | Battery voltage* <sup>1</sup>                   |                     |   |
| Combination meter                                      | Vehicle speed* <sup>2</sup>                     |                     |   |
| A/C auto amp.  | A/C ON signal* <sup>2</sup>                     |                     |   |
|  | A/C evaporator temperature* <sup>2</sup>        |                     |   |
|  | Target A/C evaporator temperature* <sup>2</sup> |                     |   |
|  | Blower ON signal                                |                     |   |

\*1: The ECM determines the start signal status by the signals of engine speed and battery voltage.

\*2: This signal is sent to ECM via the CAN communication line.

### SYSTEM DESCRIPTION

ECM controls cooling fan speed corresponding to vehicle speed, engine coolant temperature, air conditioner ON signal, refrigerant pressure, target A/C evaporator temperature and A/C evaporator temperature.

Cooling fan control signal is sent to IPDM E/R from ECM via the CAN communication line. Then, IPDM E/R sends ON/OFF pulse duty signal to cooling fan control module. Corresponding to this ON/OFF pulse duty signal, cooling fan control module gives cooling fan motor operating voltage to cooling fan motors. Cooling fan speed is controlled by duty cycle of cooling fan motor operating voltage sent from cooling fan control module.

### ELECTRIC IGNITION SYSTEM

# SYSTEM

< SYSTEM DESCRIPTION >

[VK56VD FOR MEXICO]

## ELECTRIC IGNITION SYSTEM : System Diagram

INFOID:000000007758148

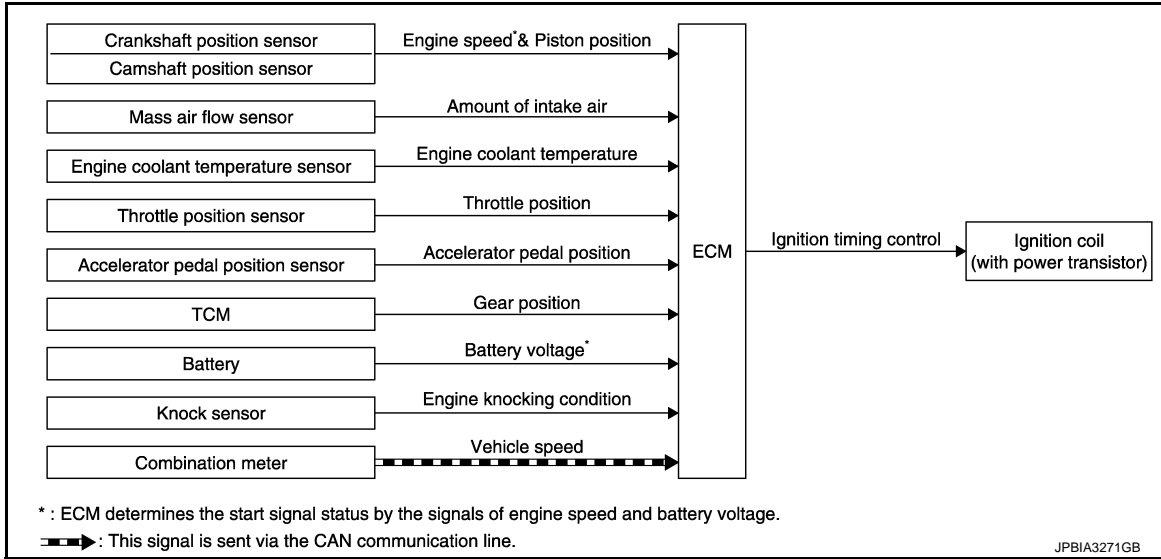

## ELECTRIC IGNITION SYSTEM : System Description

INFOID:000000007758149

### INPUT/OUTPUT SIGNAL CHART

| Sensor                            | Input signal to ECM                           | ECM function            | Actuator                                 |
|-----------------------------------|---|-------------------------|--|
| Crankshaft position sensor        | Engine speed* <sup>1</sup><br>Piston position | Ignition timing control | Ignition coil<br>(with power transistor) |
| Camshaft position sensor          |   |                         |  |
| Mass air flow sensor              | Amount of intake air                          |                         |  |
| Engine coolant temperature sensor | Engine coolant temperature                    |                         |  |
| Throttle position sensor          | Throttle position                             |                         |  |
| Accelerator pedal position sensor | Accelerator pedal position                    |                         |  |
| TCM                               | Gear position                                 |                         |  |
| Battery                           | Battery voltage* <sup>1</sup>                 |                         |  |
| Knock sensor                      | Engine knocking                               |                         |  |
| Combination meter                 | Vehicle speed* <sup>2</sup>                   |                         |  |

\*1: ECM determines the start signal status by the signals of engine speed and battery voltage.

\*2: This signal is sent to the ECM via the CAN communication line.

### SYSTEM DESCRIPTION

Ignition order: 1 - 8 - 7 - 3 - 6 - 5 - 4 - 2

The ignition timing is controlled by the ECM to maintain the best air-fuel ratio for every running condition of the engine. The ignition timing data is stored in the ECM.

The ECM receives information such as the injection pulse width and camshaft position sensor signal. Computing this information, ignition signals are transmitted to the power transistor.

During the following conditions, the ignition timing is revised by the ECM according to the other data stored in the ECM.

- At starting
- During warm-up
- At idle
- At low battery voltage
- During acceleration

The knock sensor retard system is designed only for emergencies. The basic ignition timing is programmed within the anti-knocking zone, if recommended fuel is used under dry conditions. The retard system does not operate under normal driving conditions. If engine knocking occurs, the knock sensor monitors the condition. The signal is transmitted to the ECM. The ECM retards the ignition timing to eliminate the knocking condition.



INTAKE VALVE TIMING CONTROL

INTAKE VALVE TIMING CONTROL : System Diagram

INFOID:000000007758150

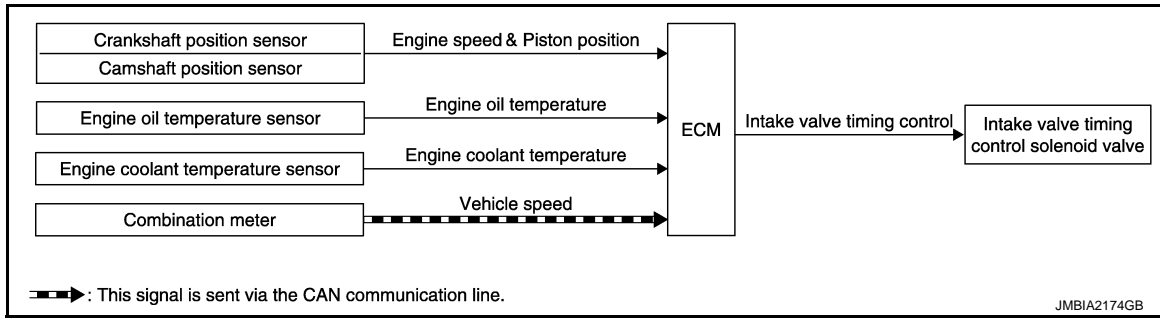

INTAKE VALVE TIMING CONTROL : System Description

INFOID:000000007758151

INPUT/OUTPUT SIGNAL CHART

| Sensor                            | Input signal to ECM              | ECM function                | Actuator                                   |
|-----------------------------------|----------------------------------|-----------------------------|--|
| Crankshaft position sensor        | Engine speed and piston position | Intake valve timing control | Intake valve timing control solenoid valve |
| Camshaft position sensor          |                                  |                             |  |
| Engine oil temperature sensor     | Engine oil temperature           |                             |  |
| Engine coolant temperature sensor | Engine coolant temperature       |                             |  |
| Combination meter                 | Vehicle speed*                   |                             |  |

\*: This signal is sent to the ECM via the CAN communication line.

SYSTEM DESCRIPTION

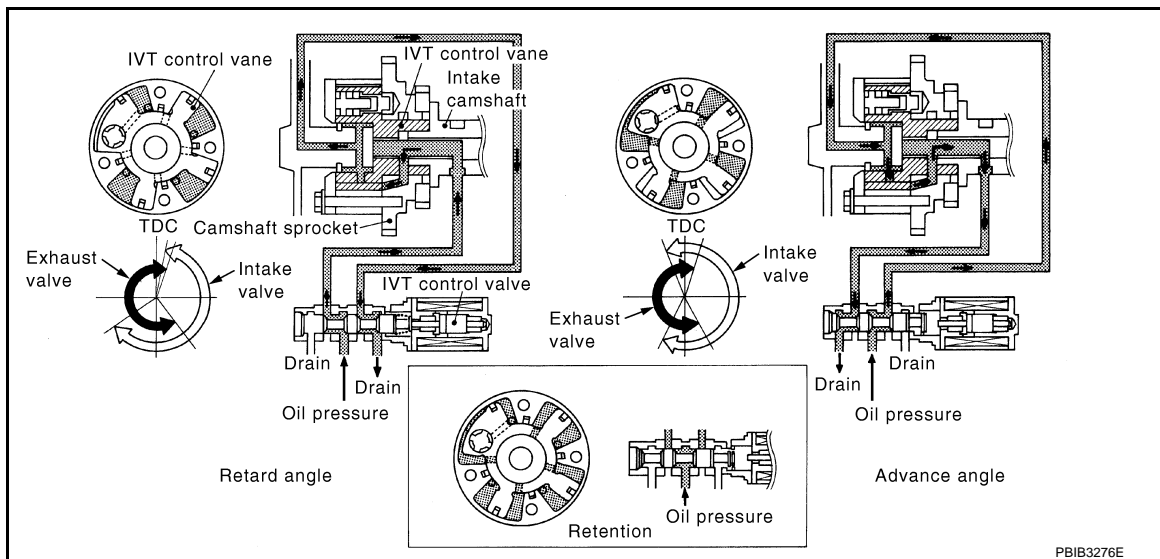

This mechanism hydraulically controls cam phases continuously with the fixed operating angle of the intake valve.

The ECM receives signals such as crankshaft position, camshaft position, engine speed, and engine coolant temperature. Then, the ECM sends ON/OFF pulse duty signals to the intake valve timing control solenoid valve depending on driving status. This makes it possible to control the shut/open timing of the intake valve to increase engine torque in low/mid speed range and output in high speed range.

EXHAUST VALVE TIMING CONTROL

# SYSTEM

< SYSTEM DESCRIPTION >

[VK56VD FOR MEXICO]

## EXHAUST VALVE TIMING CONTROL : System Diagram

INFOID:000000007758152

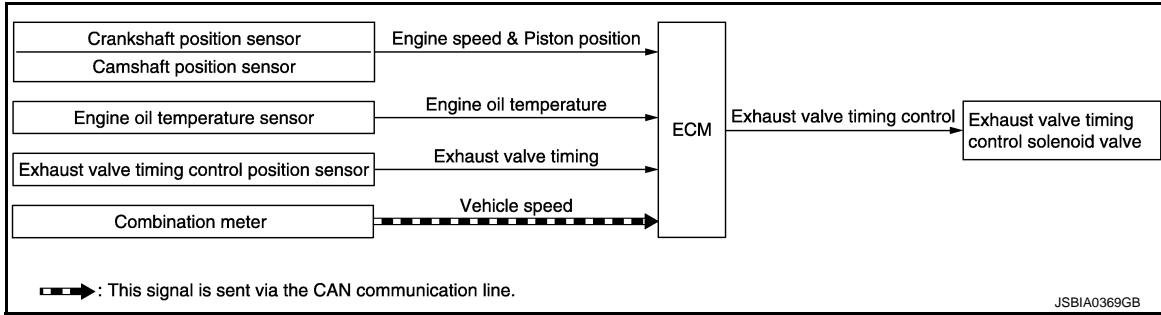

## EXHAUST VALVE TIMING CONTROL : System Description

INFOID:000000007758153

### INPUT/OUTPUT SIGNAL CHART

| Sensor                                       | Input signal to ECM              | ECM function                 | Actuator                                    |
|--|----------------------------------|------------------------------|---|
| Crankshaft position sensor                   | Engine speed and piston position | Exhaust valve timing control | Exhaust valve timing control solenoid valve |
| Camshaft position sensor                     |                                  |                              |   |
| Engine oil temperature sensor                | Engine oil temperature           |                              |   |
| Exhaust valve timing control position sensor | Exhaust valve timing signal      |                              |   |
| Combination meter                            | Vehicle speed*                   |                              |   |

\*: This signal is sent to the ECM via the CAN Communication line

### SYSTEM DESCRIPTION

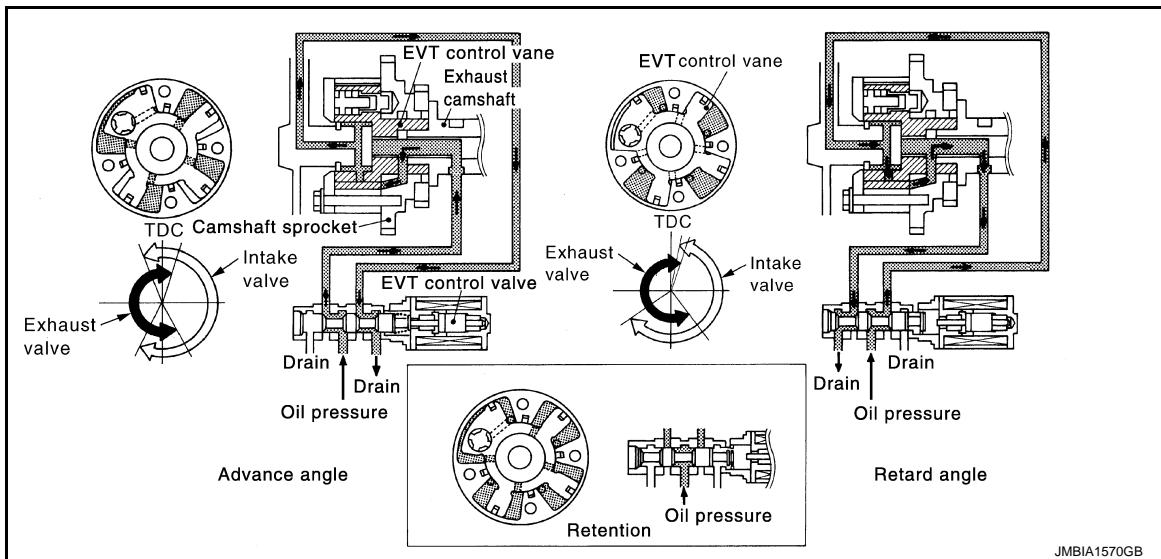

This mechanism hydraulically controls cam phases continuously with the fixed operating angle of the exhaust valve.

The ECM receives signals such as crankshaft position, camshaft position, engine speed, and engine oil temperature. Then, the ECM sends ON/OFF pulse duty signals to the exhaust valve timing control solenoid valve depending on driving status. This makes it possible to control the shut/open timing of the exhaust valve to increase engine torque and output in a range of high engine speed.

### VVEL SYSTEM

# SYSTEM

< SYSTEM DESCRIPTION >

[VK56VD FOR MEXICO]

## VVEL SYSTEM : System Diagram

INFOID:000000007758154

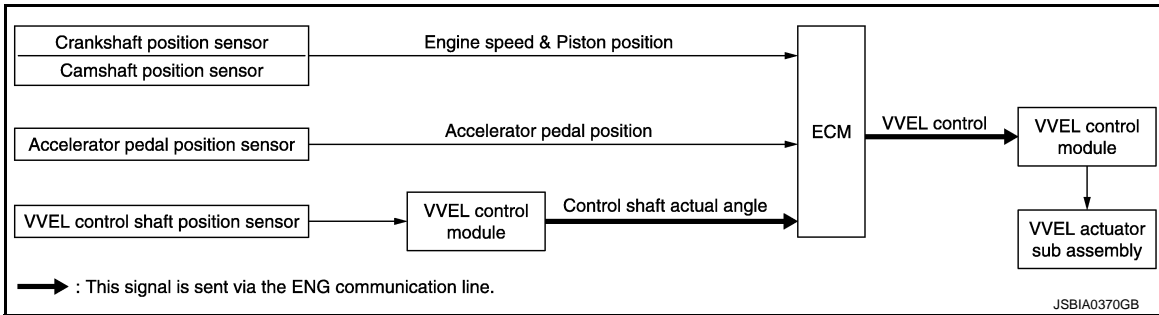

## VVEL SYSTEM : System Description

INFOID:000000007758155

### INPUT/OUTPUT SIGNAL CHART

| Sensor   | Input signal to ECM              | ECM function | Actuator   |
|--|----------------------------------|--------------|--|
| Camshaft position sensor<br>Crankshaft position sensor         | Engine speed and piston position | VVEL control | VVEL control module<br>↓<br>VVEL actuator sub assembly |
| Accelerator pedal position sensor                              | Accelerator pedal position       |              |  |
| VVEL control shaft position sensor<br>↓<br>VVEL control module | Control shaft actual angle       |              |  |

### SYSTEM DESCRIPTION

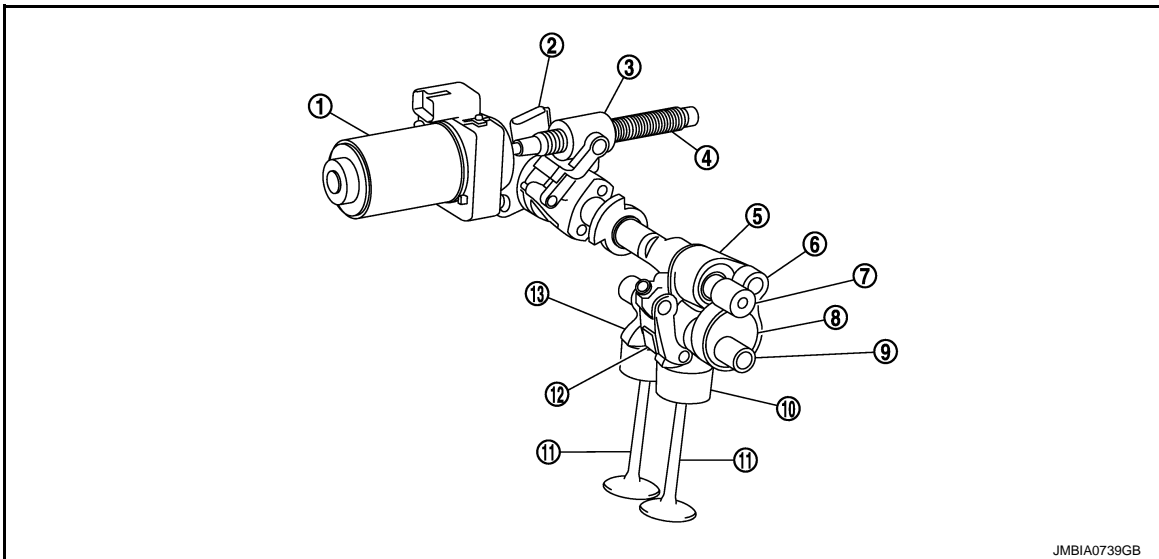

- |                        |                                       |                   |
|------------------------|---------------------------------------|-------------------|
| 1. VVEL actuator motor | 2. VVEL control shaft position sensor | 3. Ball screw nut |
| 4. Ball screw shaft    | 5. Rocker arm                         | 6. Link A         |
| 7. Control shaft       | 8. Eccentric cam                      | 9. Drive shaft    |
| 10. Valve lifter       | 11. Intake valve                      | 12. Link B        |
| 13. Output cam         |                                       |                   |

VVEL (Variable Valve Event & Lift) is a system that controls valve event and valve lift continuously. Rotational movement of the drive shaft equipped with eccentric cam is transmitted to output cam via the rocker arm and two kinds of links to depress the intake valve. ECM decides the target valve lift according to the driving condition and sends the command signal to the VVEL control module. The VVEL control module controls the rotation of the control shaft using the VVEL actuator motor and changes the movement of the output cam by shifting the link supporting point. As a result, valve lift changes continuously to improve engine output and response.

EVAPORATIVE EMISSION SYSTEM

EVAPORATIVE EMISSION SYSTEM : System Diagram

INFOID:000000007758156

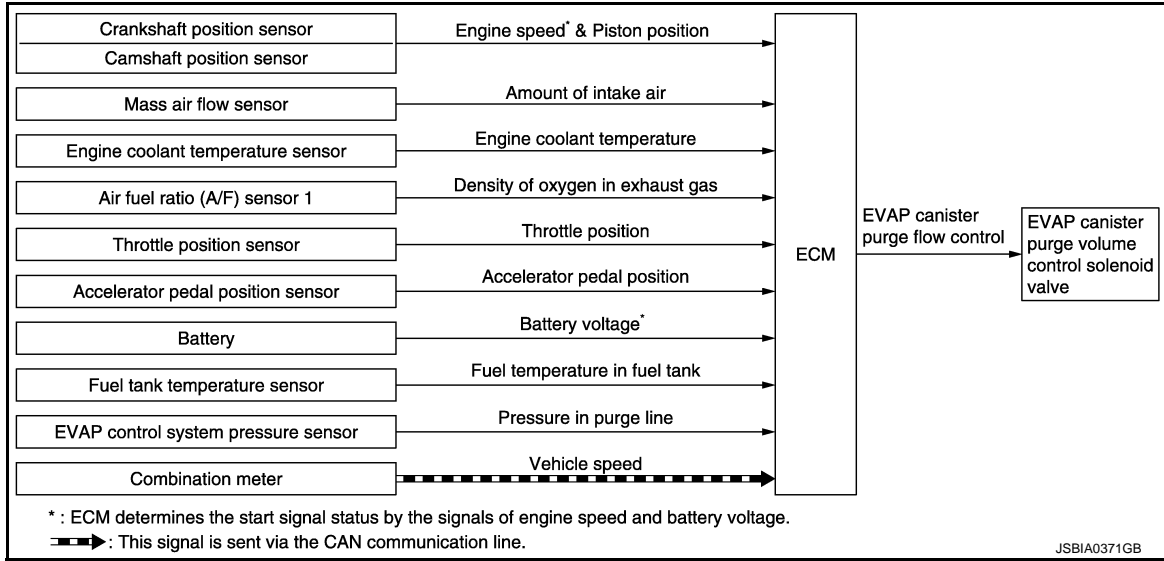

EVAPORATIVE EMISSION SYSTEM : System Description

INFOID:000000007758157

INPUT/OUTPUT SIGNAL CHART

| Sensor   | Input signal to ECM   | ECM function                        | Actuator   |
|--|---|-------------------------------------|--|
| Crankshaft position sensor<br>Camshaft position sensor | Engine speed*1  | EVAP canister<br>purge flow control | EVAP canister purge volume<br>control solenoid valve |
| Mass air flow sensor                                   | Amount of intake air  |                                     |  |
| Engine coolant temperature sensor                      | Engine coolant temperature  |                                     |  |
| Battery  | Battery voltage*1   |                                     |  |
| Throttle position sensor                               | Throttle position   |                                     |  |
| Accelerator pedal position sensor                      | Accelerator pedal position  |                                     |  |
| Air fuel ratio (A/F) sensor 1                          | Density of oxygen in exhaust gas<br>(Mixture ratio feedback signal) |                                     |  |
| Fuel tank temperature sensor                           | Fuel temperature in fuel tank                                       |                                     |  |
| EVAP control system pressure sensor                    | Pressure in purge line  |                                     |  |
| Combination meter                                      | Vehicle speed*2   |                                     |  |

\*1: ECM determines the start signal status by the signals of engine speed and battery voltage.

\*2: This signal is sent to the ECM via the CAN communication line.

# SYSTEM

< SYSTEM DESCRIPTION >

[VK56VD FOR MEXICO]

## SYSTEM DESCRIPTION

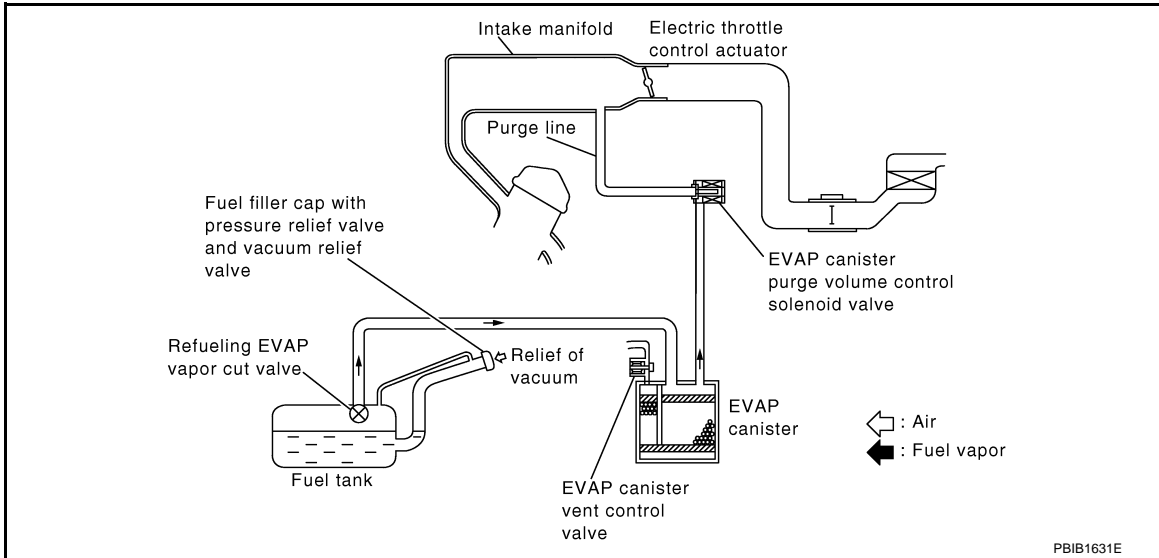

The evaporative emission system is used to reduce hydrocarbons emitted into the atmosphere from the fuel system. This reduction of hydrocarbons is accomplished by activated charcoals in the EVAP canister. The fuel vapor in the sealed fuel tank is led into the EVAP canister which contains activated carbon and the vapor is stored there when the engine is not operating or when refueling to the fuel tank. The vapor in the EVAP canister is purged by the air through the purge line to the intake manifold when the engine is operating. EVAP canister purge volume control solenoid valve is controlled by ECM. When the engine operates, the flow rate of vapor controlled by EVAP canister purge volume control solenoid valve is proportionally regulated as the air flow increases. EVAP canister purge volume control solenoid valve also shuts off the vapor purge line during decelerating and idling.

## AIR CONDITIONING CUT CONTROL

### AIR CONDITIONING CUT CONTROL : System Diagram

INFOID:000000007758158

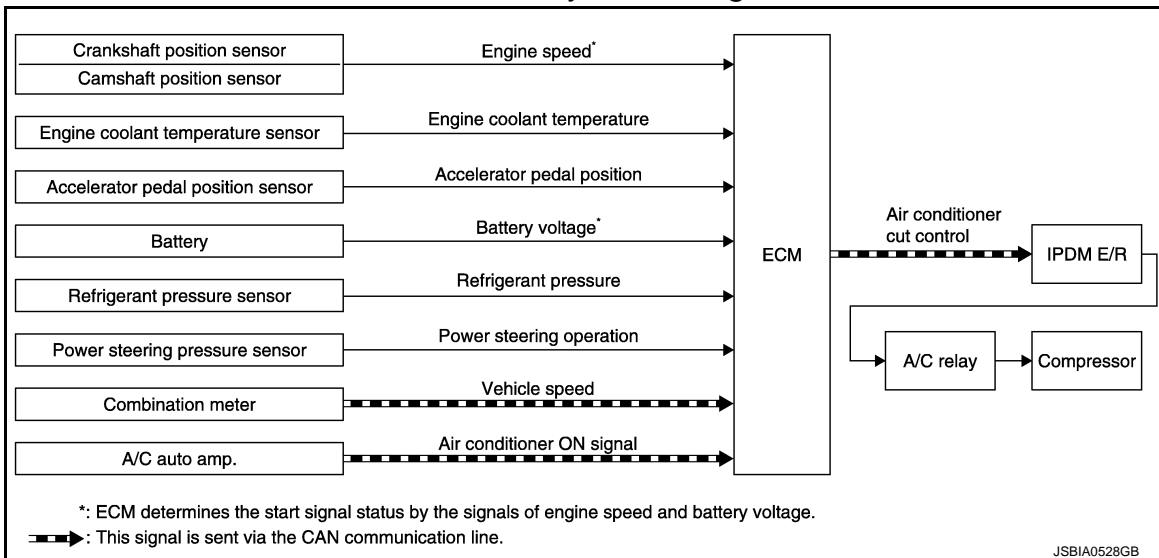

### AIR CONDITIONING CUT CONTROL : System Description

INFOID:000000007758159

#### INPUT/OUTPUT SIGNAL CHART

# SYSTEM

< SYSTEM DESCRIPTION >

[VK56VD FOR MEXICO]

| Sensor   | Input signal to ECM                 | ECM function                   | Actuator                                      |
|--|-------------------------------------|--------------------------------|---|
| Crankshaft position sensor<br>Camshaft position sensor | Engine speed*1                      | Air conditioner<br>cut control | IPDM E/R<br>↓<br>A/C relay<br>↓<br>Compressor |
| Engine coolant temperature sensor                      | Engine coolant temperature          |                                |   |
| Accelerator pedal position sensor                      | Accelerator pedal position          |                                |   |
| Battery  | Battery voltage*1                   |                                |   |
| Refrigerant pressure sensor                            | Refrigerant pressure                |                                |   |
| Power steering pressure sensor                         | Power steering operation            |                                |   |
| A/C auto amp.  | A/C ON signal*2                     |                                |   |
|  | A/C evaporator temperature*2        |                                |   |
|  | Target A/C evaporator temperature*2 |                                |   |
|  | Blower ON signal                    |                                |   |
| Combination meter                                      | Vehicle speed*2                     |                                |   |

\*1: The ECM determines the start signal status by the signals of engine speed and battery voltage.

\*2: This signal is sent to ECM via the CAN communication line.

## SYSTEM DESCRIPTION

This system improves engine operation when the air conditioner is used. Under the following conditions, the air conditioner is turned off.

- When the accelerator pedal is fully depressed.
- When cranking the engine.
- At high engine speeds.
- When the engine coolant temperature becomes excessively high.
- When operating power steering during low engine speed or low vehicle speed.
- When engine speed is excessively low.
- When refrigerant pressure is excessively low or high.

## CAN COMMUNICATION

### CAN COMMUNICATION : System Description

INFOID:000000007758164

CAN (Controller Area Network) is a serial communication line for real time application. It is an on-vehicle multiplex communication line with high data communication speed and excellent error detection ability. Many electronic control units are equipped onto a vehicle, and each control unit shares information and links with other control units during operation (not independent). In CAN communication, control units are connected with 2 communication lines (CAN H line, CAN L line) allowing a high rate of information transmission with less wiring. Each control unit transmits/receives data but selectively reads required data only.

Refer to [LAN-35, "CAN COMMUNICATION SYSTEM : CAN Communication Signal Chart"](#), about CAN communication for detail.

### Infiniti Drive Mode Selector

## Infiniti Drive Mode Selector : System Description

INFOID:000000007758165

### System Diagram

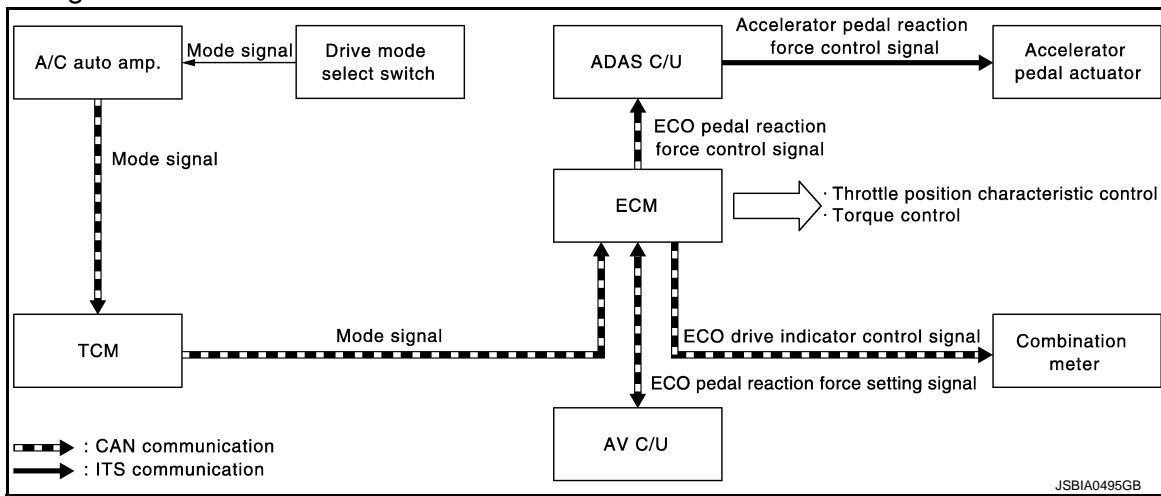

**NOTE:**

- This section provides descriptions only about the control by ECM.  
For overall control, refer to [DMS-5, "Infiniti Drive Mode Selector : System Description"](#).
- ECO pedal control is only for vehicles with intelligent pedal (distance control assist).

#### Infiniti drive mode selector

- A/C auto amp. receives an operation state signal of the drive mode select switch and transmits a mode signal (see below) to TCM via CAN communication.
  - STANDARD: ON/OFF
  - SPORT: ON/OFF
  - ECO: ON/OFF
  - SNOW: ON/OFF
- TCM transmits a mode state signal to ECM via CAN communication, based on a ECO mode signal received from the A/C auto amp.
- ECM controls throttle angle characteristics and torque appropriate to each mode, based on a ECO mode signal received from TCM via CAN communication.
- The combination meter turns ON or blinks (with ECO pedal) the ECO drive indicator when in ECO mode, based on a ECO drive indicator control signal received from ECM via CAN communication.

#### ECO pedal control

- The AV control unit transmits an ECO pedal reaction force setting signal (Standard/Soft/OFF) to ECM via CAN communication.

**NOTE:**

- An ECO pedal reaction force setting signal which determines reaction force of the accelerator pedal can be selected on the settings screen of the Multi AV system.
- ECM transmits an ECO pedal reaction force control signal to the ADAS control unit via CAN communication, based on a ECO mode signal received from TCM via CAN communication and an ECO pedal reaction force setting signal received from the AV control unit via CAN communication.
- ECM sends back an ECO pedal reaction force setting signal received from the AV control unit to the AV control unit for confirmation.
- The ADAS control unit controls pedal reaction force of the accelerator pedal actuator via ITS communication, based on an ECO pedal reaction force control signal received from the ADAS control unit.

#### Control

- With the drive mode selector, a drive mode select switch installed at the top of the center console switches a vehicle drive mode, changes throttle angle characteristics, and controls torque and ECO pedal.
- Vehicle characteristics are controlled in the following modes, on the basis of STANDARD mode (“●” position of the drive mode select switch).
  - SPORT: Changing throttle angle characteristics allows to use a high engine performance range and increases driving performance.
  - ECO: Changing throttle angle characteristics and controlling torque, ECO drive indicator, and ECO pedal enhance fuel economy in actual traffic.

# SYSTEM

## < SYSTEM DESCRIPTION >

[VK56VD FOR MEXICO]

- SNOW: Changing throttle angle characteristics enhances driving performance on roads with a low coefficient of friction.

| Control item            | Vehicle drive mode |     |      | Description  |
|-------------------------|--------------------|-----|------|--|
|                         | SPORT              | ECO | SNOW |  |
| Engine                  | ×                  | ×   | ×    | Changes throttle angle and controls torque* <sup>1</sup> and the ECO drive indicator* <sup>1</sup> . |
| ECO pedal* <sup>2</sup> |                    | ×   |      | Controls ECO pedal (Accelerator pedal reaction force control).                                       |

\*1: Torque control and the ECO drive indicator is available only when in ECO mode.

\*2: ECO pedal control is only for vehicles with an intelligent pedal (distance control assist).

### ECO drive indicator control

- ECO drive indicator turns ON or blinks (with ECO pedal) when in ECO mode, according to the operation of the accelerator pedal.
- For vehicles with ECO pedal, the blinking timing of the ECO drive indicator (green) synchronizes to the generation timing of ECO pedal reaction force.

| ECO drive indicator                      | Driving condition   |
|--|---|
| ON (Green)                               | Within the ECO drive range.   |
| Blink (Green) (if so equipped ECO pedal) | Likely over the ECO drive range.  |
| ON (Orange)                              | Over the ECO drive range.   |
| OFF                                      | Low-speed range [approx. 3 MPH (4.8 km/h) or less] and high-speed range [approx. 90 MPH (144 km/h) or more] |

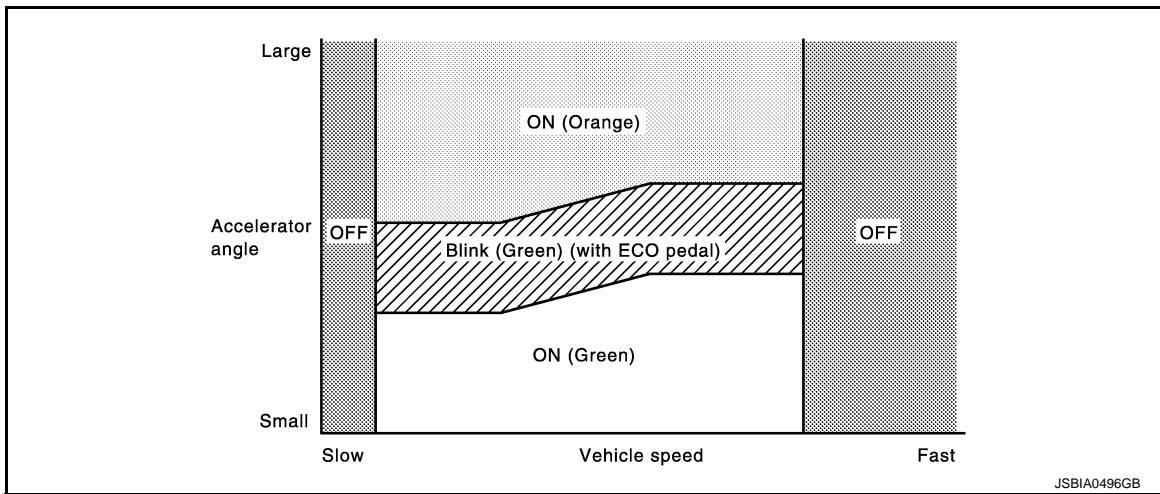

### NOTE:

ECO drive indicator turns OFF under the following conditions.

- Intelligent cruise control in operation.
- Selector lever is in R range.

### ECO pedal control

- Increasing reaction force of the accelerator pedal supports ECO driving in accordance with the accelerator pedal operation when in ECO mode.
- The level of reaction force to the accelerator pedal can be changed among Standard/Soft/OFF on the navigation screen. ECO pedal reaction force can be turned OFF even when in ECO mode.
- The generation timing of ECO pedal reaction force synchronizes to the blinking timing of the ECO drive indicator (Green).



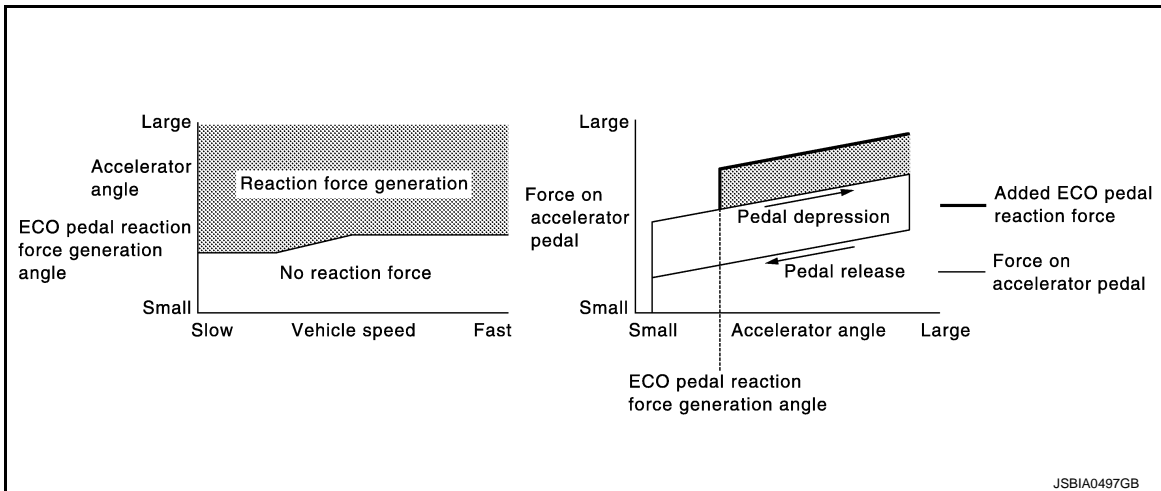

**NOTE:**

- When switching from ECO mode to the other mode by operating the drive mode select switch, ECO pedal reaction force is generated in common with ECO mode until the accelerator pedal is released.
- ECO pedal reaction force is not generated under the following conditions.
  - Intelligent cruise control is in operation.
  - Accelerator pedal is depressed quickly.
  - Selector lever is in N or R range.

**ALTERNATOR POWER GENERATION VOLTAGE VARIABLE CONTROL SYSTEM**

**ALTERNATOR POWER GENERATION VOLTAGE VARIABLE CONTROL SYSTEM : System Description**

INFOID:000000007784276

The alternator power generation voltage variable control system controls the amount of power generation, according to a battery loaded condition. ECM judges a battery condition, according to a signal received from the battery current sensor which detects a charge/discharge current. ECM then transmits a signal to IPDM E/R to command power generation via CAN communication. IPDM E/R transmits a power generation control signal to the alternator so that the system can control the amount of power generation. The voltage of power generation is lowered during battery low-load conditions and boosted under heavy load conditions. In this way, the system reduces the engine load through the adequate power generation control.

For details, refer to [CHG-8. "POWER GENERATION VOLTAGE VARIABLE CONTROL SYSTEM : System Diagram"](#).

## HANDLING PRECAUTION

## Infiniti Drive Mode Selector

INFOID:000000007758167

## ECO DRIVE INDICATOR LAMP CONTROL

- ECO drive indicator turns OFF under the following conditions.
  - While driving at low speeds [3 MPH (4.8 km/h) or less] or high speeds [90 MPH (144 km/h) or more].
  - Intelligent cruise control is in operation.
  - Selector lever is in R range.

## ECO PEDAL CONTROL

- When switching from ECO mode to the other mode by operating the drive mode select switch, ECO pedal reaction force is generated in common with ECO mode until the accelerator pedal is released.
- ECO pedal reaction force is not generated under the following conditions.
  - Intelligent cruise control is in operation.
  - Accelerator pedal is depressed quickly.
  - Selector lever is in N or R range.
  - ECO pedal reaction force setting is OFF.

**NOTE:**

ECO pedal control is only for vehicles with an intelligent pedal (distance control assist).

## ENGINE OUTPUT CHARACTERISTICS AFTER SWITCHING MODE

- Engine output characteristics after switching mode by operating the drive mode select switch are as follows.
  - After switching mode to a mode that engine output increase, engine output characteristics are changed by releasing the accelerator pedal.
  - After switching mode to a mode that engine output decreases, engine output characteristics are changed immediately.
- When an accelerator angle is constant, engine output characteristics are as follows.
  - SPORT > STANDARD > ECO > SNOW

Output characteristics of each mode

| Control mode | Engine output                           |
|--------------|---|
| SPORT        | Increase                                |
| STANDARD     | Normal                                  |
| ECO          | Decrease                                |
| SNOW         | Decrease (More reduction than ECO mode) |

# ON BOARD DIAGNOSTIC (OBD) SYSTEM

< SYSTEM DESCRIPTION >

[VK56VD FOR MEXICO]

## ON BOARD DIAGNOSTIC (OBD) SYSTEM

### Diagnosis Description

INFOID:000000007758168

This system is an on board diagnostic system that records exhaust emission-related diagnostic information and detects a sensors/actuator-related malfunction. A malfunction is indicated by the malfunction indicator lamp (MIL) and stored in ECU memory as a DTC. The diagnostic information can be obtained with the diagnostic tool (GST: Generic Scan Tool).

### GST (Generic Scan Tool)

INFOID:000000007758169

When GST is connected with a data link connector equipped on the vehicle side, it will communicate with the control unit equipped in the vehicle and then enable various kinds of diagnostic tests. Refer to [EC-1603](#), "[Diagnosis Description](#)".

A

EC

C

D

E

F

G

H

I

J

K

L

M

N

O

P

## DIAGNOSIS SYSTEM (ECM)

### DIAGNOSIS DESCRIPTION

#### DIAGNOSIS DESCRIPTION : 1st Trip Detection Logic and Two Trip Detection Logic

INFOID:000000007758170

When a malfunction is detected for the first time, 1st trip DTC and 1st trip Freeze Frame data are stored in the ECM memory. The MIL will not illuminate at this stage. <1st trip>

If the same malfunction is detected again during the next drive, the DTC and Freeze Frame data are stored in the ECM memory, and the MIL illuminates. The MIL illuminates at the same time when the DTC is stored. <2nd trip> The "trip" in the "Two Trip Detection Logic" means a driving mode in which self-diagnosis is performed during vehicle operation. Specific on board diagnostic items will cause the ECM to illuminate or blink the MIL, and store DTC and Freeze Frame data, even in the 1st trip, as shown below.

×: Applicable —: Not applicable

| Items   | MIL      |            |          |            | DTC                 |                     | 1st trip DTC        |                     |
|---|----------|------------|----------|------------|---------------------|---------------------|---------------------|---------------------|
|   | 1st trip |            | 2nd trip |            | 1st trip displaying | 2nd trip displaying | 1st trip displaying | 2nd trip displaying |
|   | Blinking | Illuminate | Blinking | Illuminate |                     |                     |                     |                     |
| Misfire (Possible three way catalyst damage) — DTC: P0300 - P0308 is being detected | ×        | —          | —        | —          | —                   | —                   | ×                   | —                   |
| Misfire (Possible three way catalyst damage) — DTC: P0300 - P0308 is being detected | —        | —          | ×        | —          | —                   | ×                   | —                   | —                   |
| One trip detection diagnoses (Refer to <a href="#">EC-1651, "DTC Index"</a> .)      | —        | ×          | —        | —          | ×                   | —                   | —                   | —                   |
| Except above  | —        | —          | —        | ×          | —                   | ×                   | ×                   | —                   |

#### DIAGNOSIS DESCRIPTION : DTC and Freeze Frame Data

INFOID:000000007758171

#### DTC AND 1ST TRIP DTC

The 1st trip DTC (whose number is the same as the DTC number) is displayed for the latest self-diagnostic result obtained. If the ECM memory was cleared previously, and the 1st trip DTC did not recur, the 1st trip DTC will not be displayed.

If a malfunction is detected during the 1st trip, the 1st trip DTC is saved in the ECM memory. The MIL will not light up (two trip detection logic). If the same malfunction is not detected in the 2nd trip (meeting the required driving pattern), the 1st trip DTC is cleared from the ECM memory. If the same malfunction is detected in the 2nd trip, both the 1st trip DTC and DTC are saved in the ECM memory and the MIL lights up. In other words, the DTC is stored in the ECM memory and the MIL lights up when the same malfunction occurs in two consecutive trips. If a 1st trip DTC is stored and a non-diagnostic operation is performed between the 1st and 2nd trips, only the 1st trip DTC will continue to be stored. For malfunctions that blink or light up the MIL during the 1st trip, the DTC and 1st trip DTC are stored in the ECM memory.

For malfunctions in which 1st trip DTCs are displayed, refer to [EC-1651, "DTC Index"](#). These items are required by legal regulations to continuously monitor the system/component. In addition, the items monitored non-continuously are also displayed on CONSULT.

1st trip DTC is specified in Service \$07 of SAE J1979/ISO 15031-5. 1st trip DTC detection occurs without illuminating the MIL and therefore does not warn the driver of a malfunction.

When a 1st trip DTC is detected, check, print out or write down and erase (1st trip) DTC and Freeze Frame data as specified in Work Flow procedure Step 2, refer to [EC-1675, "Work Flow"](#). Then perform DTC Confirmation Procedure or Component Function Check to try to duplicate the malfunction. If the malfunction is duplicated, the item requires repair.

#### FREEZE FRAME DATA AND 1ST TRIP FREEZE FRAME DATA

The ECM records the driving conditions such as fuel system status, calculated load value, engine coolant temperature, short term fuel trim, long term fuel trim, engine speed, vehicle speed, absolute throttle position, base fuel schedule and intake air temperature at the moment a malfunction is detected.

Data which are stored in the ECM memory, along with the 1st trip DTC, are called 1st trip freeze frame data. The data, stored together with the DTC data, are called freeze frame data and displayed on CONSULT or GST. The 1st trip freeze frame data can only be displayed on the CONSULT screen.

# DIAGNOSIS SYSTEM (ECM)

[VK56VD FOR MEXICO]

## < SYSTEM DESCRIPTION >

Only one set of freeze frame data (either 1st trip freeze frame data or freeze frame data) can be stored in the ECM. 1st trip freeze frame data is stored in the ECM memory along with the 1st trip DTC. There is no priority for 1st trip freeze frame data and it is updated each time a different 1st trip DTC is detected. However, once freeze frame data (2nd trip detection/MIL on) is stored in the ECM memory, 1st trip freeze frame data is no longer stored. Remember, only one set of freeze frame data can be stored in the ECM. The ECM has the following priorities to update the data.

| Priority | Items                      |  |
|----------|----------------------------|--|
| 1        | Freeze frame data          | Misfire — DTC: P0300 - P0308<br>Fuel Injection System Function — DTC: P0171, P0172, P0174, P0175 |
| 2        |                            | Except the above items   |
| 3        | 1st trip freeze frame data |  |

For example, the EGR malfunction (Priority: 2) was detected and the freeze frame data was saved in the 2nd trip. After that when the misfire (Priority: 1) is detected in another trip, the freeze frame data will be updated from the EGR malfunction to the misfire. The 1st trip freeze frame data is updated each time a different malfunction is detected. There is no priority for 1st trip freeze frame data. However, once freeze frame data is stored in the ECM memory, 1st trip freeze data is no longer stored (because only one freeze frame data or 1st trip freeze frame data can be stored in the ECM). If freeze frame data is stored in the ECM memory and freeze frame data with the same priority occurs later, the first (original) freeze frame data remains unchanged in the ECM memory.

Both 1st trip freeze frame data and freeze frame data (along with the DTCs) are cleared when the ECM memory is erased.

## DIAGNOSIS DESCRIPTION : Counter System

INFOID:000000007758172

### RELATIONSHIP BETWEEN MIL, 1ST TRIP DTC, DTC, AND DETECTABLE ITEMS

- When a malfunction is detected for the first time, the 1st trip DTC and the 1st trip freeze frame data are stored in the ECM memory.
- When the same malfunction is detected in two consecutive trips, the DTC and the freeze frame data are stored in the ECM memory, and the MIL will come on.
- The MIL will turn OFF after the vehicle is driven 3 times (driving pattern B) with no malfunction. The drive is counted only when the recorded driving pattern is met (as stored in the ECM). If another malfunction occurs while counting, the counter will reset.
- The DTC and the freeze frame data will be stored until the vehicle is driven 40 times (driving pattern A) without the same malfunction recurring (except for Misfire and Fuel Injection System). For Misfire and Fuel Injection System, the DTC and freeze frame data will be stored until the vehicle is driven 80 times (driving pattern C) without the same malfunction recurring. The "TIME" in "SELF-DIAGNOSTIC RESULTS" mode of CONSULT will count the number of times the vehicle is driven.
- The 1st trip DTC is not displayed when the self-diagnosis results in OK for the 2nd trip.

### COUNTER SYSTEM CHART

| Items                               | Fuel Injection System | Misfire           | Other          |
|-------------------------------------|-----------------------|-------------------|----------------|
| MIL (turns OFF)                     | 3 (pattern B)         | 3 (pattern B)     | 3 (pattern B)  |
| DTC, Freeze Frame Data (no display) | 80 (pattern C)        | 80 (pattern C)    | 40 (pattern A) |
| 1st Trip DTC (clear)                | 1 (pattern C), *1     | 1 (pattern C), *1 | 1 (pattern B)  |
| 1st Trip Freeze Frame Data (clear)  | *1, *2                | *1, *2            | 1 (pattern B)  |

For details about patterns B and C under "Fuel Injection System" and "Misfire", see "EXPLANATION FOR DRIVING PATTERNS FOR "MISFIRE <EXHAUST QUALITY DETERIORATION>", "FUEL INJECTION SYSTEM".

For details about patterns A and B under Other, see "EXPLANATION FOR DRIVING PATTERNS FOR "MISFIRE <EXHAUST QUALITY DETERIORATION>", "FUEL INJECTION SYSTEM".

- \*1: Clear timing is at the moment OK is detected.
- \*2: Clear timing is when the same malfunction is detected in the 2nd trip.

Relationship Between MIL, DTC, 1st Trip DTC and Driving Patterns for "Misfire <Exhaust Quality Deterioration>", "Fuel Injection System"

# DIAGNOSIS SYSTEM (ECM)

< SYSTEM DESCRIPTION >

[VK56VD FOR MEXICO]

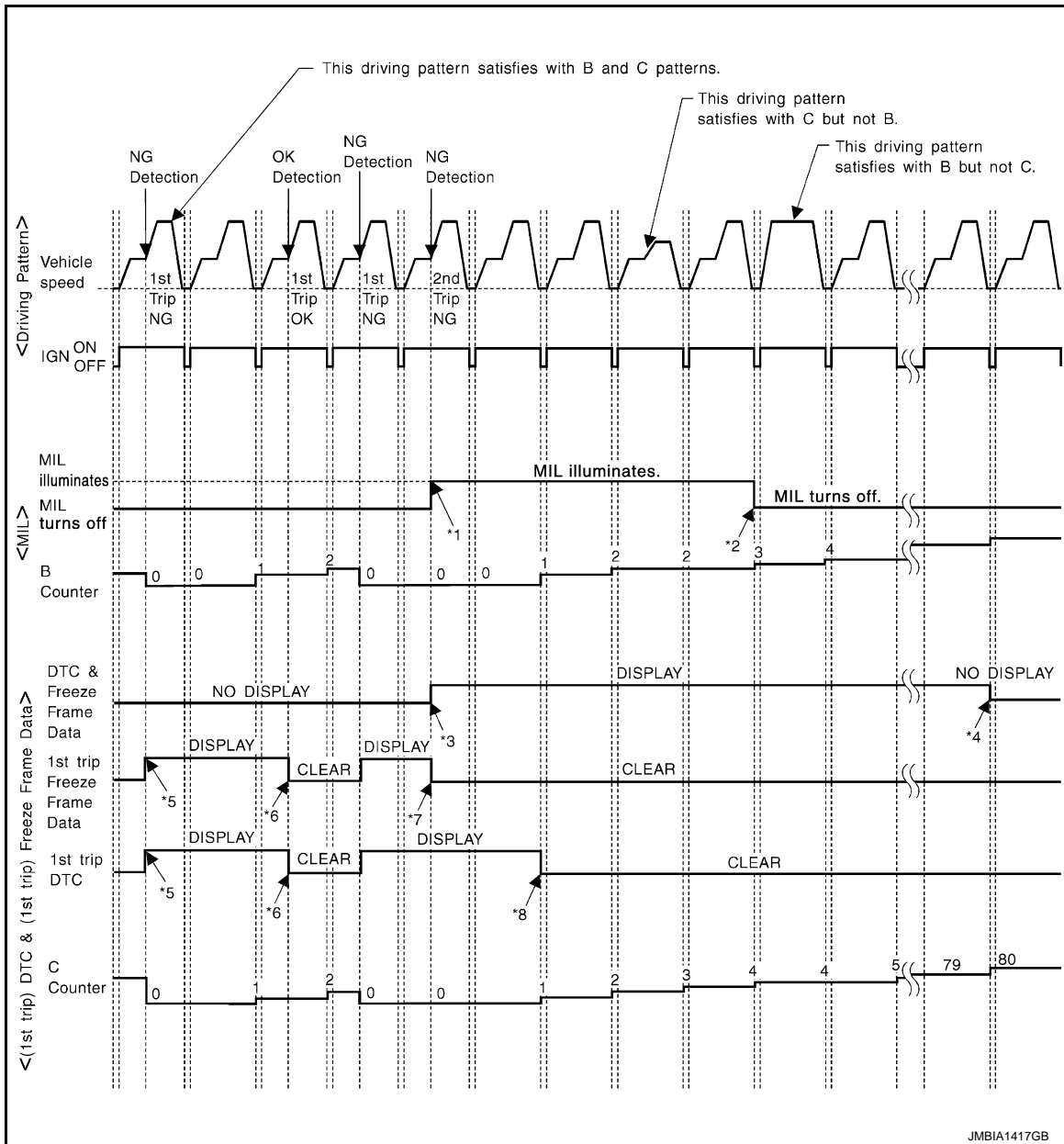

- \*1: When the same malfunction is detected in two consecutive trips, MIL will light up.
- \*2: MIL will turn OFF after vehicle is driven 3 times (pattern B) without any malfunctions.
- \*3: When the same malfunction is detected in two consecutive trips, the DTC and the freeze frame data will be stored in ECM.
- \*4: The DTC and the freeze frame data will not be displayed any longer after vehicle is driven 80 times (pattern C) without the same malfunction. (The DTC and the freeze frame data still remain in ECM.)
- \*5: When a malfunction is detected for the first time, the 1st trip DTC and the 1st trip freeze frame data will be cleared at the moment OK is detected.
- \*6: The 1st trip DTC and the 1st trip freeze frame data will be cleared at the moment OK is detected.
- \*7: When the same malfunction is detected in the 2nd trip, the 1st trip freeze frame data will be cleared.
- \*8: 1st trip DTC will be cleared when vehicle is driven once (pattern C) without the same malfunction after DTC is stored in ECM.

Explanation for Driving Patterns for "Misfire <Exhaust Quality Deterioration>", "Fuel Injection System"  
 <Driving Pattern B>  
 Driving pattern B means the vehicle operation as per the following:  
 All components and systems should be monitored at least once by the OBD system.

# DIAGNOSIS SYSTEM (ECM)

[VK56VD FOR MEXICO]

## < SYSTEM DESCRIPTION >

- The B counter will be cleared when the malfunction is detected once regardless of the driving pattern.
- The B counter will be counted up when driving pattern B is satisfied without any malfunction.
- The MIL will turn OFF when the B counter reaches 3. (\*2 in "OBD SYSTEM OPERATION CHART")

### <Driving Pattern C>

Driving pattern C means operating vehicle as per the following:

The following conditions should be satisfied at the same time:

Engine speed: (Engine speed in the freeze frame data)  $\pm 375$  rpm

Calculated load value: (Calculated load value in the freeze frame data)  $\times (1 \pm 0.1)$  [%]

Engine coolant temperature (T) condition:

- When the freeze frame data shows lower than 70°C (158°F), T should be lower than 70°C (158°F).
- When the freeze frame data shows higher than or equal to 70°C (158°F), T should be higher than or equal to 70°C (158°F).

Example:

If the stored freeze frame data is as per the following:

Engine speed: 850 rpm, Calculated load value: 30%, Engine coolant temperature: 80°C (176°F)

To be satisfied with driving pattern C, the vehicle should run under the following conditions:

Engine speed: 475 - 1,225 rpm, Calculated load value: 27 - 33%, Engine coolant temperature: more than 70°C (158°F)

- The C counter will be cleared when the malfunction is detected regardless of vehicle conditions above.
- The C counter will be counted up when vehicle conditions above are satisfied without the same malfunction.
- The DTC will not be displayed after C counter reaches 80.
- The 1st trip DTC will be cleared when C counter is counted once without the same malfunction after DTC is stored in ECM.

Relationship Between MIL, DTC, 1st Trip DTC and Driving Patterns Except For "Misfire <Exhaust Quality Deterioration>", "Fuel Injection System"

A

EC

C

D

E

F

G

H

I

J

K

L

M

N

O

P

# DIAGNOSIS SYSTEM (ECM)

< SYSTEM DESCRIPTION >

[VK56VD FOR MEXICO]

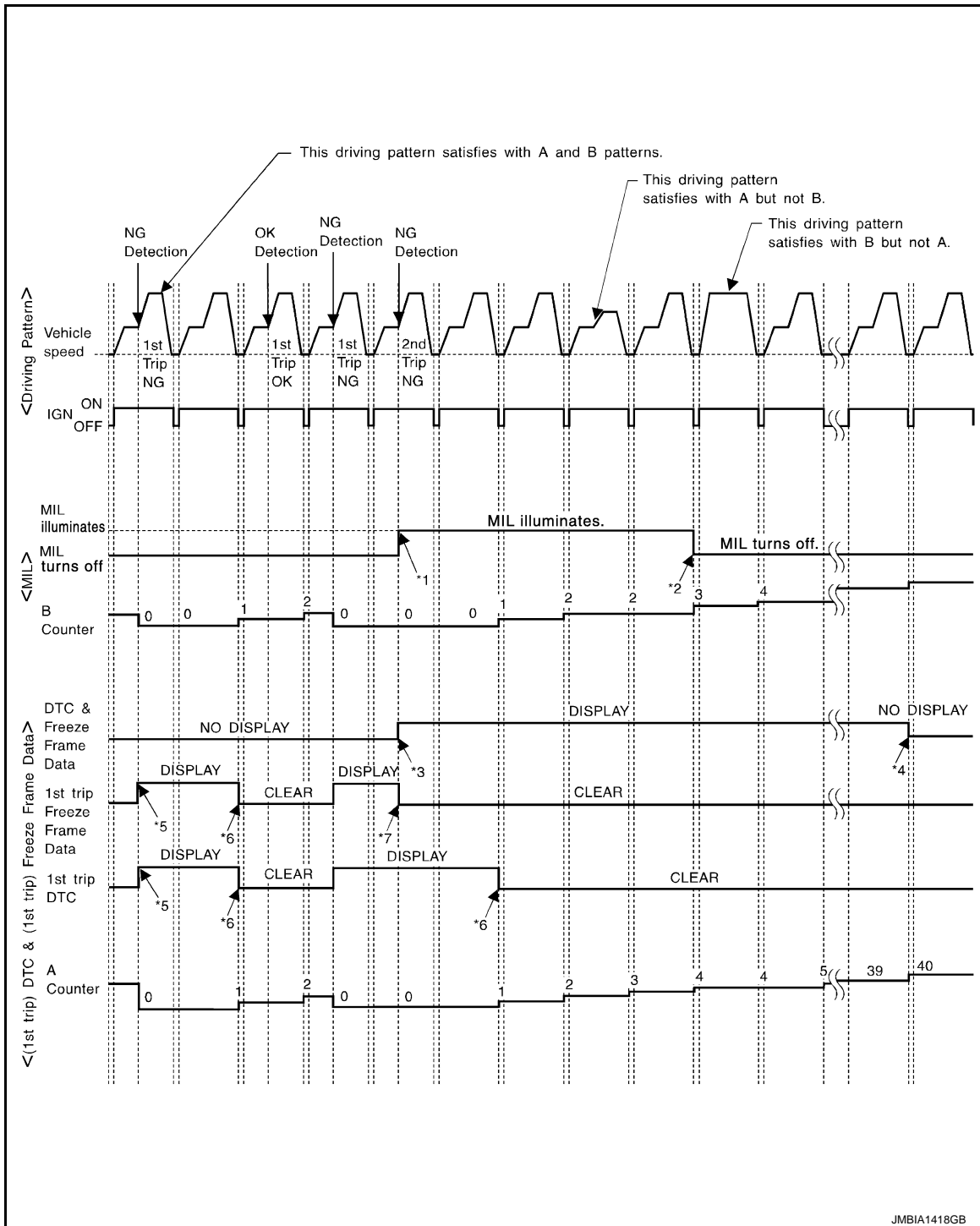

\*1: When the same malfunction is detected in two consecutive trips, MIL will light up.

\*2: MIL will turn OFF after vehicle is driven 3 times (pattern B) without any malfunctions.

\*3: When the same malfunction is detected in two consecutive trips, the DTC and the freeze frame data will be stored in ECM.

JMBIA1418GB



< SYSTEM DESCRIPTION >

\*4: The DTC and the freeze frame data will not be displayed any longer after vehicle is driven 40 times (pattern A) without the same malfunction.  
(The DTC and the freeze frame data still remain in ECM.)

\*5: When a malfunction is detected for the first time, the 1st trip DTC and the 1st trip freeze frame data will be stored in ECM.

\*6: 1st trip DTC will be cleared after vehicle is driven once (pattern B) without the same malfunction.

\*7: When the same malfunction is detected in the 2nd trip, the 1st trip freeze frame data will be cleared.

A

EC

C

## Explanation for Driving Patterns Except for “Misfire <Exhaust Quality Deterioration>”, “Fuel Injection System”

### <Driving Pattern A>

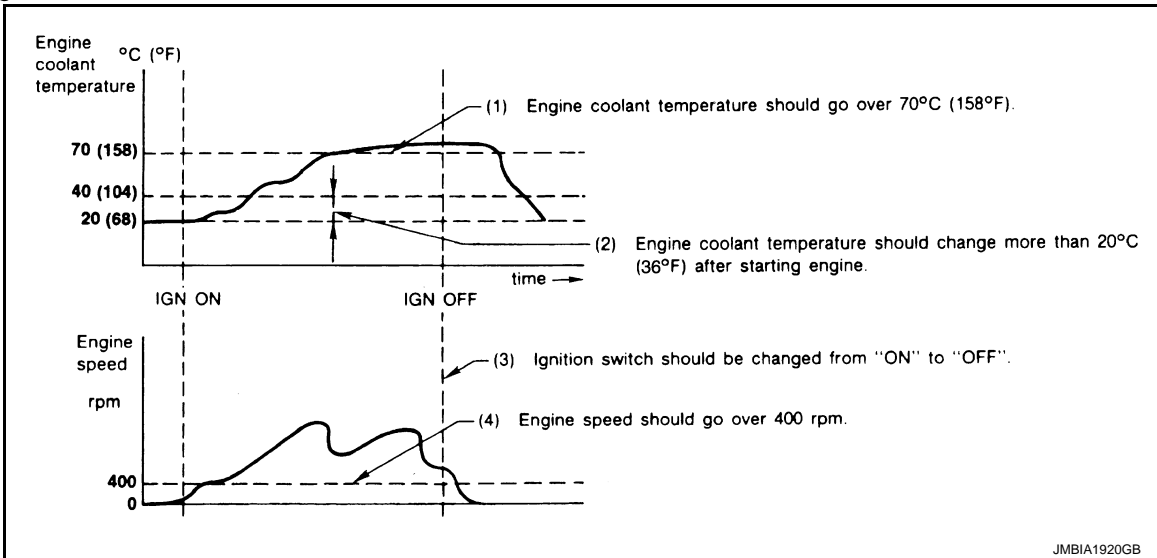

D

E

F

G

H

I

- The A counter will be cleared when the malfunction is detected regardless of (1) - (4).
- The A counter will be counted up when (1) - (4) are satisfied without the same malfunction.
- The DTC will not be displayed after the A counter reaches 40.

### <Driving Pattern B>

Driving pattern B means operating vehicle operation as per the following:

All components and systems should be monitored at least once by the OBD system.

- The B counter will be cleared when the malfunction is detected once regardless of the driving pattern.
- The B counter will be counted up when driving pattern B is satisfied without any malfunctions.
- The MIL will turn OFF when the B counter reaches 3 (\*2 in OBD SYSTEM OPERATION CHART).

J

K

L

M

N

O

P

## DIAGNOSIS DESCRIPTION : Driving Pattern

INFOID:000000007758173

### DRIVING PATTERN A

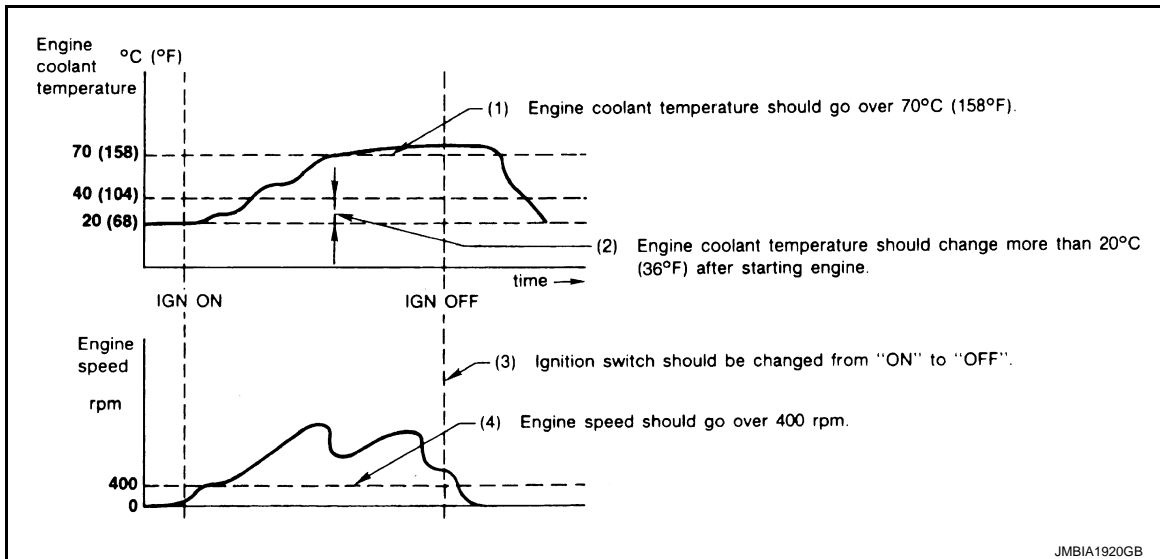

- The A counter will be cleared when the malfunction is detected regardless of (1) - (4).
- The A counter will be counted up when (1) - (4) are satisfied without the same malfunction.
- The DTC will not be displayed after the A counter reaches 40.

### DRIVING PATTERN B

Driving pattern B means operating vehicle operation as per the following:

All components and systems should be monitored at least once by the OBD system.

- The B counter will be cleared when the malfunction is detected once regardless of the driving pattern.
- The B counter will be counted up when driving pattern B is satisfied without any malfunctions.
- The MIL will turn OFF when the B counter reaches 3.

### DRIVING PATTERN C

Driving pattern C means operating vehicle as per the following:

The following conditions should be satisfied at the same time:

Engine speed: (Engine speed in the freeze frame data)  $\pm 375$  rpm

Calculated load value: (Calculated load value in the freeze frame data)  $\times (1 \pm 0.1)$  [%]

Engine coolant temperature (T) condition:

- When the freeze frame data shows lower than 70°C (158°F), T should be lower than 70°C (158°F).
- When the freeze frame data shows higher than or equal to 70°C (158°F), T should be higher than or equal to 70°C (158°F).
- The C counter will be cleared when the malfunction is detected regardless of vehicle conditions above.
- The C counter will be counted up when vehicle conditions above are satisfied without the same malfunction.
- The DTC will not be displayed after C counter reaches 80.
- The 1st trip DTC will be cleared when C counter is counted once without the same malfunction after DTC is stored in ECM.

## DIAGNOSIS DESCRIPTION : System Readiness Test (SRT) Code

INFOID:000000007758174

System Readiness Test (SRT) code is specified in Service \$01 of SAE J1979/ISO 15031-5.

As part of an enhanced emissions test for Inspection & Maintenance (I/M), certain states require the status of SRT be used to indicate whether the ECM has completed self-diagnosis of major emission systems and components. Completion must be verified in order for the emissions inspection to proceed.

If a vehicle is rejected for a State emissions inspection due to one or more SRT items indicating "INCMP", use the information in this Service Manual to set the SRT to "CMPLT".

In most cases the ECM will automatically complete its self-diagnosis cycle during normal usage, and the SRT status will indicate "CMPLT" for each application system. Once set as "CMPLT", the SRT status remains "CMPLT" until the self-diagnosis memory is erased.

Occasionally, certain portions of the self-diagnostic test may not be completed as a result of the customer's normal driving pattern; the SRT will indicate "INCMP" for these items.

**NOTE:**

# DIAGNOSIS SYSTEM (ECM)

< SYSTEM DESCRIPTION >

[VK56VD FOR MEXICO]

The SRT will also indicate "INCMP" if the self-diagnosis memory is erased for any reason or if the ECM memory power supply is interrupted for several hours.

If, during the state emissions inspection, the SRT indicates "CMPLT" for all test items, the inspector will continue with the emissions test. However, if the SRT indicates "INCMP" for one or more of the SRT items the vehicle is returned to the customer untested.

**NOTE:**

If MIL is ON during the state emissions inspection, the vehicle is also returned to the customer untested even though the SRT indicates "CMPLT" for all test items. Therefore, it is important to check SRT ("CMPLT") and DTC (No DTCs) before the inspection.

**SRT SET TIMING**

SRT is set as "CMPLT" after self-diagnosis has been performed one or more times. Completion of SRT is done regardless of whether the result is OK or NG. The set timing is different between OK and NG results and is shown in the table below.

| Self-diagnosis result |        | Example        |                |            |              |                        |
|-----------------------|--------|----------------|----------------|------------|--------------|------------------------|
|                       |        | Diagnosis      | Ignition cycle |            |              |                        |
|                       |        |                | ← ON → OFF     | ← ON → OFF | ← ON → OFF   | ← ON →                 |
| All OK                | Case 1 | P0400          | OK (1)         | — (1)      | OK (2)       | — (2)                  |
|                       |        | P0402          | OK (1)         | — (1)      | — (1)        | OK (2)                 |
|                       |        | P1402          | OK (1)         | OK (2)     | — (2)        | — (2)                  |
|                       |        | SRT of EGR     | "CMPLT"        | "CMPLT"    | "CMPLT"      | "CMPLT"                |
|                       | Case 2 | P0400          | OK (1)         | — (1)      | — (1)        | — (1)                  |
|                       |        | P0402          | — (0)          | — (0)      | OK (1)       | — (1)                  |
|                       |        | P1402          | OK (1)         | OK (2)     | — (2)        | — (2)                  |
|                       |        | SRT of EGR     | "INCMP"        | "INCMP"    | "CMPLT"      | "CMPLT"                |
| NG exists             | Case 3 | P0400          | OK             | OK         | —            | —                      |
|                       |        | P0402          | —              | —          | —            | —                      |
|                       |        | P1402          | NG             | —          | NG           | NG<br>(Consecutive NG) |
|                       |        | (1st trip) DTC | 1st trip DTC   | —          | 1st trip DTC | DTC<br>(= MIL ON)      |
|                       |        | SRT of EGR     | "INCMP"        | "INCMP"    | "INCMP"      | "CMPLT"                |

OK: Self-diagnosis is carried out and the result is OK.

NG: Self-diagnosis is carried out and the result is NG.

—: Self-diagnosis is not carried out.

When all SRT related self-diagnoses show OK results in a single cycle (Ignition OFF-ON-OFF), the SRT will indicate "CMPLT". → Case 1 above

When all SRT related self-diagnoses show OK results through several different cycles, the SRT will indicate "CMPLT" at the time the respective self-diagnoses have at least one OK result. → Case 2 above

If one or more SRT related self-diagnoses show NG results in 2 consecutive cycles, the SRT will also indicate "CMPLT". → Case 3 above

The table above shows that the minimum number of cycles for setting SRT as "INCMP" is the number one (1) for each self-diagnosis (Case 1 & 2) or the number two (2) for one of self-diagnoses (Case 3). However, in preparation for the state emissions inspection, it is unnecessary for each self-diagnosis to be executed twice (Case 3) for the following reasons:

- The SRT will indicate "CMPLT" at the time the respective self-diagnoses have one (1) OK result.
- The emissions inspection requires "CMPLT" of the SRT only with OK self-diagnosis results.
- During SRT driving pattern, the 1st trip DTC (NG) is detected prior to "CMPLT" of SRT and the self-diagnosis memory must be erased from the ECM after repair.
- If the 1st trip DTC is erased, all the SRT will indicate "INCMP".

**NOTE:**

SRT can be set as "CMPLT" together with the DTC(s). Therefore, DTC check must always be carried out prior to the state emission inspection even though the SRT indicates "CMPLT".

# DIAGNOSIS SYSTEM (ECM)

< SYSTEM DESCRIPTION >

[VK56VD FOR MEXICO]

## DIAGNOSIS DESCRIPTION : Malfunction Indicator Lamp (MIL)

INFOID:000000007758175

When emission related ECU detects a malfunction in the emission control systems components and/or the powertrain control components (which affect vehicle emissions), it turns on/blinks MIL to inform the driver that a malfunction has been detected.

1. The MIL illuminates when ignition switch is turned ON (engine is not running).

**NOTE:**

Check the MIL circuit if MIL does not illuminate. Refer to [EC-1992, "Component Function Check"](#).

2. When the engine is started, the MIL should go off.

**NOTE:**

If MIL continues to illuminate/blink, perform self-diagnoses and inspect/repair accordingly because an emission related ECU has detected a malfunction in the emission control systems components and/or the powertrain control components (which affect vehicle emissions).

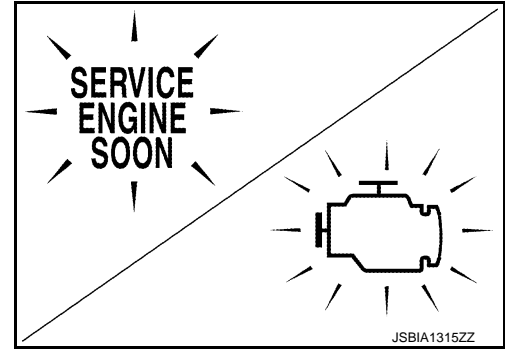

## On Board Diagnosis Function

INFOID:000000007758176

### ON BOARD DIAGNOSIS ITEM

The on board diagnostic system has the following functions.

| Diagnostic test mode                          | Function  |
|---|---|
| Bulb check                                    | MIL can be checked.   |
| SRT status                                    | ECM can read if SRT codes are set.  |
| Malfunction warning                           | If ECM detects a malfunction, it illuminates or blinks MIL to inform the driver that a malfunction has been detected.             |
| Self-diagnostic results                       | DTCs or 1st trip DTCs stored in ECM can be read.  |
| Accelerator pedal released position learning  | ECM can learn the accelerator pedal released position. Refer to <a href="#">EC-1685, "Description"</a> .                          |
| Throttle valve closed position learning       | ECM can learn the throttle valve closed position. Refer to <a href="#">EC-1686, "Description"</a> .                               |
| Idle air volume learning                      | ECM can learn the idle air volume. Refer to <a href="#">EC-1687, "Description"</a> .  |
| VVEL control shaft position sensor adjustment | The initial position of the VVEL control shaft position sensor can be adjusted. Refer to <a href="#">EC-1689, "Description"</a> . |

### BLUB CHECK MODE

#### Description

This function allows damage inspection in the MIL bulb (blown, open circuit, etc.).

#### Operation Procedure

1. Turn ignition switch ON.
2. The MIL on the instrument panel should stay ON.  
If it remains OFF, check MIL circuit. Refer to [EC-1992, "Diagnosis Procedure"](#).

### SRT STATUS MODE

#### Description

This function allows to read if ECM has completed the self-diagnoses of major emission control systems and components. For SRT, refer to [EC-1610, "DIAGNOSIS DESCRIPTION : System Readiness Test \(SRT\) Code"](#).

#### Operation Procedure

1. Turn ignition switch ON and wait 20 seconds.
2. SRT status is indicated as shown blow.
  - ECM continues to illuminate MIL if all SRT codes are set.

- ECM blinks MIL for about 10 seconds if all SRT codes are not set.

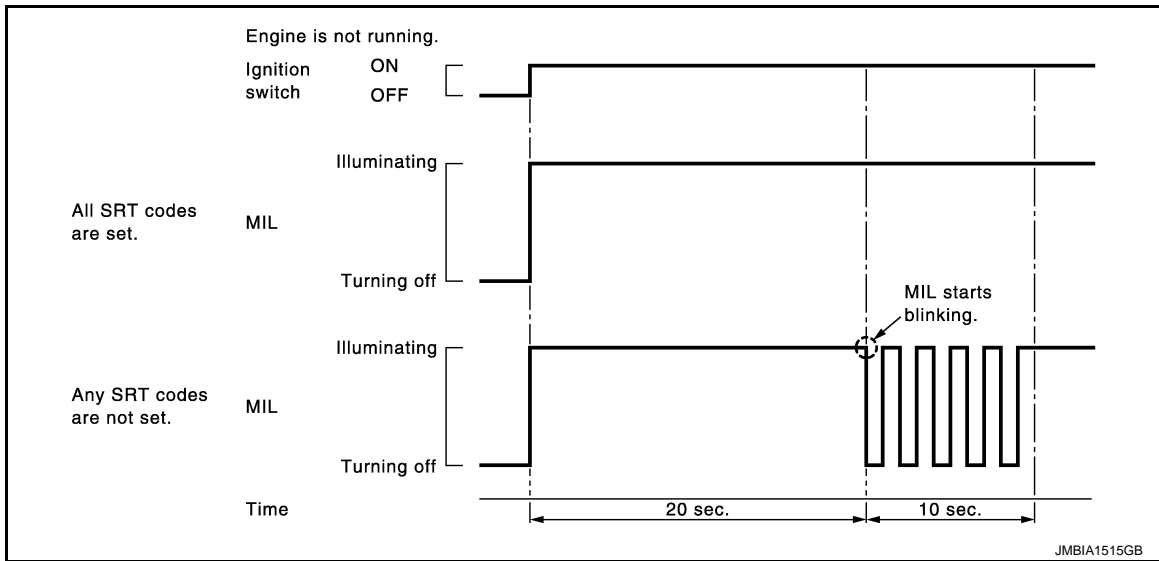

## MALFUNCTION WARNING MODE

### Description

In this function ECM turns on or blinks MIL when it detects a malfunction in the emission control system components and/or the powertrain control components (which affect vehicle emissions) to inform the driver that a malfunction has been detected.

### Operation Procedure

1. Turn ignition switch ON.
2. Check that MIL illuminates.  
If it remains OFF, check MIL circuit. Refer to [EC-1992, "Diagnosis Procedure"](#).
3. Start engine and let it idle.
  - For two trip detection logic diagnoses, ECM turns on MIL when it detects the same malfunction twice in the two consecutive driving cycles.
  - For 1st trip detection logic diagnoses, ECM turns on MIL when it detects a malfunction in one driving cycle.
  - ECM blinks MIL when it detects a malfunction that may damage the three way catalyst (misfire).

## SELF-DIAGNOSTIC RESULTS MODE

### Description

This function allows to indicate DTCs or 1st trip DTCs stored in ECM according to the number of times MIL is blinking.

### How to Set Self diagnostic Results Mode

#### NOTE:

- It is better to count the time accurately with a clock.
  - It is impossible to switch the diagnostic mode when an accelerator pedal position sensor circuit has a malfunction.
  - After ignition switch is turned off, ECM is always released from the "Self-diagnostic results" mode.
1. Confirm that accelerator pedal is fully released, turn ignition switch ON and wait 3 seconds.
  2. Repeat the following procedure quickly five times within 5 seconds.
    - Fully depress the accelerator pedal.
    - Fully release the accelerator pedal.
  3. Wait 7 seconds, fully depress the accelerator pedal and keep it depressed for approx. 10 seconds until the MIL starts blinking.

#### NOTE:

Do not release the accelerator pedal for 10 seconds if MIL starts blinking during this period. This blinking is displaying SRT status and is continued for another 10 seconds.

4. Fully release the accelerator pedal.  
ECM has entered to SELF-DIAGNOSTIC RESULTS mode.

# DIAGNOSIS SYSTEM (ECM)

< SYSTEM DESCRIPTION >

[VK56VD FOR MEXICO]

**NOTE:**

Wait until the same DTC (or 1st trip DTC) appears to completely confirm all DTCs.

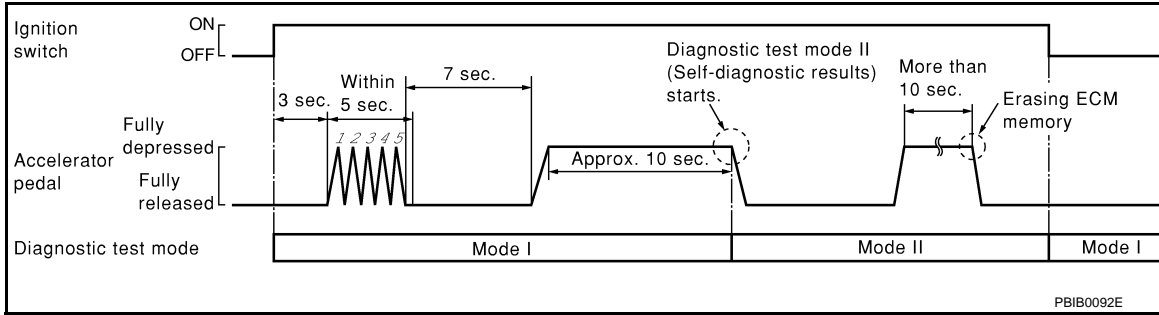

**How to Read Self diagnostic Results**

The DTC and 1st trip DTC are indicated by the number of blinks of the MIL as shown below. The DTC and 1st trip DTC are displayed at the same time. If the MIL does not illuminate in diagnostic test mode I (Malfunction warning), all displayed items are 1st trip DTCs. If only one code is displayed when the MIL illuminates in "MALFUNCTION WARNING" mode, it is a DTC; if two or more codes are displayed, they may be either DTCs or 1st trip DTCs. DTC No. is same as that of 1st trip DTC. These unidentified codes can be identified by using the CONSULT or GST. A DTC will be used as an example for how to read a code.

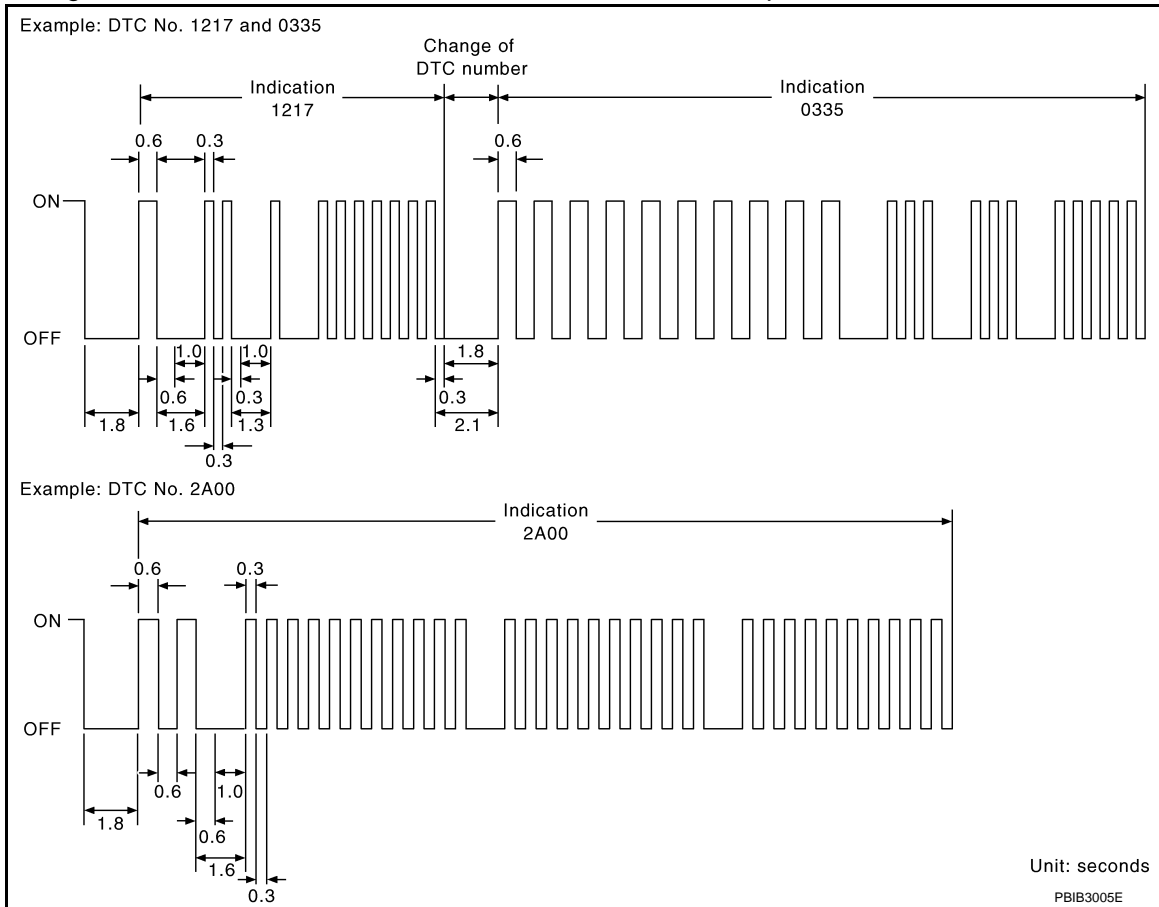

A particular trouble code can be identified by the number of four-digit numeral flashes per the following.

|         |    |   |   |   |   |   |   |   |   |   |    |    |    |    |    |    |
|---------|----|---|---|---|---|---|---|---|---|---|----|----|----|----|----|----|
| Number  | 0  | 1 | 2 | 3 | 4 | 5 | 6 | 7 | 8 | 9 | A  | B  | C  | D  | E  | F  |
| Flashes | 10 | 1 | 2 | 3 | 4 | 5 | 6 | 7 | 8 | 9 | 11 | 12 | 13 | 14 | 15 | 16 |

The length of time the 1,000th-digit numeral flashes on and off is 1.2 seconds consisting of an ON (0.6-seconds) - OFF (0.6-seconds) cycle.

The 100th-digit numeral and lower digit numerals consist of a 0.3-seconds ON and 0.3-seconds OFF cycle.

A change from one digit numeral to another occurs at an interval of 1.0-second OFF. In other words, the later numeral appears on the display 1.3 seconds after the former numeral has disappeared.

A change from one trouble code to another occurs at an interval of 1.8-seconds OFF.

# DIAGNOSIS SYSTEM (ECM)

[VK56VD FOR MEXICO]

## < SYSTEM DESCRIPTION >

In this way, all the detected malfunctions are classified by their DTC numbers. The DTC 0000 refers to no malfunction. Refer to [EC-1651, "DTC Index"](#).

### How to Erase Self diagnostic Results

By performing this procedure, ECM memory is erased and the following diagnostic information is erased as well.

- Diagnostic trouble codes
- 1st trip diagnostic trouble codes
- Freeze frame data
- 1st trip freeze frame data
- System readiness test (SRT) codes
- Test values

#### NOTE:

Also, if a battery terminal is disconnected, ECM memory is erased and the diagnostic information as listed above is erased. (The amount of time required for erasing may vary from a few seconds to several hours.)

1. Turn ignition switch OFF and wait at least 10 seconds.
2. Turn ignition switch ON.
3. Turn ignition switch OFF and wait at least 10 seconds.
4. Turn ignition switch ON.
5. Set ECM in Self-diagnostic results.
6. The diagnostic information has been erased from the backup memory in the ECM. Fully depress the accelerator pedal and keep it depressed for more than 10 seconds.
7. Fully release the accelerator pedal, and confirm the DTC 0000 is displayed.

## CONSULT Function

INFOID:000000007758177

### FUNCTION

| Diagnostic test mode   | Function  |
|------------------------|---|
| Work support           | This mode enables a technician to adjust some devices faster and more accurately by following the indications on the CONSULT unit.      |
| Self diagnostic result | Self-diagnostic results such as 1st trip DTC, DTCs and 1st trip freeze frame data or freeze frame data can be read and erased quickly.* |
| Data monitor           | Input/Output data in the ECM can be read.   |
| Active test            | Diagnostic Test Mode in which CONSULT drives some actuators apart from the ECMs and also shifts some parameters in a specified range.   |
| DTC & SRT confirmation | The status of system monitoring tests and the self-diagnosis status/results can be confirmed.   |
| Function test          | This mode is used to inform customers when the vehicle requires periodic maintenance.   |
| ECU identification     | ECM part number can be read.  |

\*: The following emission-related diagnostic information is cleared when the ECM memory is erased.

- Diagnostic trouble codes
- 1st trip diagnostic trouble codes
- Freeze frame data
- 1st trip freeze frame data
- System readiness test (SRT) codes
- Test values

## WORK SUPPORT MODE

### Work Item

| WORK ITEM             | CONDITION   | USAGE                                       |
|-----------------------|---|---|
| IDLE AIR VOL LEARN    | • The idle air volume that keeps the engine speed within the specified range is memorized in ECM. | When learning the idle air volume           |
| FUEL PRESSURE RELEASE | • Fuel pump will stop by touching "START" during idling. Crank a few times after engine stalls.   | When releasing fuel pressure from fuel line |

# DIAGNOSIS SYSTEM (ECM)

< SYSTEM DESCRIPTION >

[VK56VD FOR MEXICO]

| WORK ITEM             | CONDITION  | USAGE   |
|-----------------------|--|---|
| SELF-LEARNING CONT    | <ul style="list-style-type: none"> <li>The coefficient of self-learning control mixture ratio returns to the original coefficient.</li> </ul>                  | When clearing mixture ratio self-learning value   |
| VVEL POS SEN ADJ PREP | <ul style="list-style-type: none"> <li>Use this item only when replacing VVEL actuator sub assembly.</li> <li>Ignition switch ON and engine stopped</li> </ul> | When adjusting VVEL control shaft position sensor |
| TARGET IDLE RPM ADJ*  | <ul style="list-style-type: none"> <li>Idle condition</li> </ul>   | When setting target idle speed                    |
| TARGET IGN TIM ADJ*   | <ul style="list-style-type: none"> <li>Idle condition</li> </ul>   | When adjusting target ignition timing             |
| CLSD THL POS LEARN    | <ul style="list-style-type: none"> <li>Ignition switch ON and engine stopped</li> </ul>  | When learning the throttle valve closed position  |

\*: This function is not necessary in the usual service procedure.

## SELF-DIAG RESULTS MODE

Self Diagnostic Item

Regarding items of DTC and 1st trip DTC, refer to [EC-1651, "DTC Index"](#).

How to Read DTC and 1st Trip DTC

DTCs and 1st trip DTCs related to the malfunction are displayed in "Self-diag results".

- When ECM detects a 1st trip DTC, "1t" is displayed for "TIME".
- When ECM has detected a current DTC, "0" is displayed for "TIME".
- If "TIME" is neither "0" nor "1t", the DTC occurred in the past and ECM shows the number of times the vehicle has been driven since the last detection of the DTC.

How to Erase DTC and 1st Trip DTC

### NOTE:

- If the ignition switch stays ON after repair work, be sure to turn ignition switch OFF once. Wait at least 10 seconds and then turn it ON (engine stopped) again.
- If the DTC is not for A/T related items (see [EC-1651, "DTC Index"](#)), skip step 1.
  - Erase DTC in TCM. Refer to [TM-59, "Diagnosis Description"](#).
  - Select "ENGINE" with CONSULT.
  - Select "SELF-DIAG RESULTS".
  - Touch "ERASE". (DTC in ECM will be erased.)

Freeze Frame Data and 1st Trip Freeze Frame Data

| Freeze frame data item*      | Description   |
|------------------------------|---|
| DIAG TROUBLE CODE [PXXXX]    | <ul style="list-style-type: none"> <li>The engine control component part/control system has a trouble code the is displayed as PXXXX. (Refer to <a href="#">EC-1651, "DTC Index"</a>.)</li> </ul>   |
| CAL/LD VALUE [%]             | <ul style="list-style-type: none"> <li>The calculated load value at the moment a malfunction is detected is displayed.</li> </ul>   |
| COOLANT TEMP [°C] or [°F]    | <ul style="list-style-type: none"> <li>The engine coolant temperature at the moment a malfunction is detected is displayed.</li> </ul>  |
| L-FUEL TRM-B1 [%]            | <ul style="list-style-type: none"> <li>"Long-term fuel trim" at the moment a malfunction is detected is displayed.</li> <li>The long-term fuel trim indicates much more gradual feedback compensation to the base fuel schedule than short-term fuel trim.</li> </ul> |
| L-FUEL TRM-B2 [%]            |   |
| S-FUEL TRM-B1 [%]            | <ul style="list-style-type: none"> <li>"Short-term fuel trim" at the moment a malfunction is detected is displayed.</li> <li>The short-term fuel trim indicates dynamic or instantaneous feedback compensation to the base fuel schedule.</li> </ul>                  |
| S-FUEL TRM-B2 [%]            |   |
| ENGINE SPEED [rpm]           | <ul style="list-style-type: none"> <li>The engine speed at the moment a malfunction is detected is displayed.</li> </ul>  |
| VEHICL SPEED [km/h] or [mph] | <ul style="list-style-type: none"> <li>The vehicle speed at the moment a malfunction is detected is displayed.</li> </ul>   |
| INT MANI PRES [kPa]          | <ul style="list-style-type: none"> <li>These items are displayed but are not applicable to this model.</li> </ul>   |
| ABSOL TH-P/S [%]             | <ul style="list-style-type: none"> <li>The throttle valve opening angle at the moment a malfunction is detected is displayed.</li> </ul>  |
| B/FUEL SCHDL [msec]          | <ul style="list-style-type: none"> <li>The base fuel schedule at the moment a malfunction is detected is displayed.</li> </ul>  |



# DIAGNOSIS SYSTEM (ECM)

[VK56VD FOR MEXICO]

## < SYSTEM DESCRIPTION >

| Freeze frame data item*    | Description   |
|----------------------------|---|
| INT/A TEMP SE [°C] or [°F] | <ul style="list-style-type: none"> <li>The intake air temperature at the moment a malfunction is detected is displayed.</li> </ul>  |
| FUEL SYS-B1                | <ul style="list-style-type: none"> <li>"Fuel injection system status" at the moment a malfunction is detected is displayed.</li> <li>One of the following mode is displayed.<br/>                     Mode2: Open loop due to detected system malfunction<br/>                     Mode3: Open loop due to driving conditions (power enrichment, deceleration enrichment)<br/>                     Mode4: Closed loop - using oxygen sensor(s) as feedback for fuel control<br/>                     Mode5: Open loop - has not yet satisfied condition to go to closed loop</li> </ul> |
| FUEL SYS-B2                |   |
| COMBUST CONDIT-ION         | <ul style="list-style-type: none"> <li>These items are displayed but are not applicable to this model.</li> </ul>   |

\*: The items are the same as those of 1st trip freeze frame data.

## DATA MONITOR MODE

### Monitored Item

×: Applicable

| Monitored item  | Unit        | Description   | Remarks   |
|-----------------|-------------|---|---|
| ENG SPEED       | rpm         | <ul style="list-style-type: none"> <li>Indicates the engine speed computed from the signal of the crankshaft position sensor and camshaft position sensor.</li> </ul>   | <ul style="list-style-type: none"> <li>Accuracy becomes poor if engine speed drops below the idle rpm.</li> <li>If the signal is interrupted while the engine is running, an abnormal value may be indicated.</li> </ul>  |
| MAS A/F SE-B1   | V           | <ul style="list-style-type: none"> <li>The signal voltage of the mass air flow sensor is displayed.</li> </ul>  | <ul style="list-style-type: none"> <li>When the engine is stopped, a certain value is indicated.</li> <li>When engine is running, specification range is indicated in "SPEC".</li> </ul>  |
| MAS A/F SE-B2   |             |   |   |
| B/FUEL SCHDL    | msec        | <ul style="list-style-type: none"> <li>"Base fuel schedule" indicates the fuel injection pulse width programmed into ECM, prior to any learned on board correction.</li> </ul>  | <ul style="list-style-type: none"> <li>When engine is running, specification range is indicated in "SPEC".</li> </ul>   |
| A/F ALPHA-B1    | %           | <ul style="list-style-type: none"> <li>The mean value of the air-fuel ratio feedback correction factor per cycle is indicated.</li> </ul>   | <ul style="list-style-type: none"> <li>When the engine is stopped, a certain value is indicated.</li> <li>This data also includes the data for the air-fuel ratio learning control.</li> <li>When engine is running, specification range is indicated in "SPEC".</li> </ul> |
| A/F ALPHA-B2    |             |   |   |
| COOLAN TEMP/S   | °C or °F    | <ul style="list-style-type: none"> <li>The engine coolant temperature (determined by the signal voltage of the engine coolant temperature sensor) is displayed.</li> </ul>  | <ul style="list-style-type: none"> <li>When the engine coolant temperature sensor is open or short-circuited, ECM enters fail-safe mode. The engine coolant temperature determined by the ECM is displayed.</li> </ul>  |
| A/F SEN1 (B1)   | V           | <ul style="list-style-type: none"> <li>The A/F signal computed from the input signal of the air fuel ratio (A/F) sensor 1 is displayed.</li> </ul>  |   |
| A/F SEN1 (B2)   |             |   |   |
| HO2S2 (B1)      | V           | <ul style="list-style-type: none"> <li>The signal voltage of the heated oxygen sensor 2 is displayed.</li> </ul>  |   |
| HO2S2 (B2)      |             |   |   |
| HO2S2 MNTR (B1) | RICH/LEAN   | <ul style="list-style-type: none"> <li>Display of heated oxygen sensor 2 signal:<br/>                     RICH: means the amount of oxygen after three way catalyst is relatively small.<br/>                     LEAN: means the amount of oxygen after three way catalyst is relatively large.</li> </ul> | <ul style="list-style-type: none"> <li>When the engine is stopped, a certain value is indicated.</li> </ul>   |
| HO2S2 MNTR (B2) |             |   |   |
| VHCL SPEED SE   | km/h or mph | <ul style="list-style-type: none"> <li>The vehicle speed computed from the vehicle speed signal sent from combination meter is displayed.</li> </ul>  |   |
| BATTERY VOLT    | V           | <ul style="list-style-type: none"> <li>The power supply voltage of ECM is displayed.</li> </ul>   |   |
| ACCEL SEN 1     | V           | <ul style="list-style-type: none"> <li>The accelerator pedal position sensor signal voltage is displayed.</li> </ul>  | <ul style="list-style-type: none"> <li>ACCEL SEN 2 signal is converted by ECM internally. Thus, they differs from ECM terminal voltage signal.</li> </ul>   |
| ACCEL SEN 2     |             |   |   |

# DIAGNOSIS SYSTEM (ECM)

[VK56VD FOR MEXICO]

< SYSTEM DESCRIPTION >

| Monitored item | Unit     | Description   | Remarks   |
|----------------|----------|---|---|
| TP SEN 1-B1    | V        | <ul style="list-style-type: none"> <li>The throttle position sensor signal voltage is displayed.</li> </ul>   | <ul style="list-style-type: none"> <li>TP SEN 2-B1 signal is converted by ECM internally. Thus, they differs from ECM terminal voltage signal.</li> </ul> |
| TP SEN 2-B1    |          |   |   |
| FUEL T/TMP SE  | °C or °F | <ul style="list-style-type: none"> <li>The fuel temperature (determined by the signal voltage of the fuel tank temperature sensor) is displayed.</li> </ul>   |   |
| FUEL LEVEL SE  | V        | <ul style="list-style-type: none"> <li>The signal voltage of the fuel level sensor is displayed.</li> </ul>   |   |
| START SIGNAL   | ON/OFF   | <ul style="list-style-type: none"> <li>Indicates start signal status [ON/OFF] computed by the ECM according to the signals of engine speed and battery voltage.</li> </ul>  | <ul style="list-style-type: none"> <li>After starting the engine, [OFF] is displayed regardless of the starter signal.</li> </ul>                         |
| CLSD THL POS   | ON/OFF   | <ul style="list-style-type: none"> <li>Indicates idle position [ON/OFF] computed by ECM according to the accelerator pedal position sensor signal.</li> </ul>   |   |
| AIR COND SIG   | ON/OFF   | <ul style="list-style-type: none"> <li>Indicates [ON/OFF] condition of the air conditioner switch as determined by the air conditioner signal.</li> </ul>   |   |
| PW/ST SIGNAL   | ON/OFF   | <ul style="list-style-type: none"> <li>[ON/OFF] condition of the power steering system (determined by the signal voltage of the power steering pressure sensor signal) is indicated.</li> </ul>   |   |
| LOAD SIGNAL    | ON/OFF   | <ul style="list-style-type: none"> <li>Indicates [ON/OFF] condition from the electrical load signal.</li> <li>ON: Rear window defogger switch is ON and/or lighting switch is in 2nd position.</li> <li>OFF: Both rear window defogger switch and lighting switch are OFF.</li> </ul> |   |
| IGNITION SW    | ON/OFF   | <ul style="list-style-type: none"> <li>Indicates [ON/OFF] condition from ignition switch signal.</li> </ul>   |   |
| HEATER FAN SW  | ON/OFF   | <ul style="list-style-type: none"> <li>Indicates [ON/OFF] condition from the heater blower ON signal.</li> </ul>  |   |
| BRAKE SW       | ON/OFF   | <ul style="list-style-type: none"> <li>Indicates [ON/OFF] condition from the stop lamp switch signal.</li> </ul>  |   |
| INJ PULSE-B1   | msec     | <ul style="list-style-type: none"> <li>Indicates the actual fuel injection pulse width compensated by ECM according to the input signals.</li> </ul>  | <ul style="list-style-type: none"> <li>When the engine is stopped, a certain computed value is indicated.</li> </ul>                                      |
| INJ PULSE-B2   |          |   |   |
| IGN TIMING     | BTDC     | <ul style="list-style-type: none"> <li>Indicates the ignition timing computed by ECM according to the input signals.</li> </ul>   | <ul style="list-style-type: none"> <li>When the engine is stopped, a certain value is indicated.</li> </ul>   |
| COMBUSTION     | —        | <ul style="list-style-type: none"> <li>These items are displayed but are not applicable to this model.</li> </ul>   |   |
| CAL/LD VALUE   | %        | <ul style="list-style-type: none"> <li>"Calculated load value" indicates the value of the current air flow divided by peak air flow.</li> </ul>   |   |
| MASS AIRFLOW   | g/s      | <ul style="list-style-type: none"> <li>Indicates the mass air flow computed by ECM according to the signal voltage of the mass air flow sensor.</li> </ul>  |   |
| PURG VOL C/V   | %        | <ul style="list-style-type: none"> <li>Indicates the EVAP canister purge volume control solenoid valve control value computed by the ECM according to the input signals.</li> <li>The opening becomes larger as the value increases.</li> </ul>                                       |   |
| EXH/V TIM B1   | °CA      | <ul style="list-style-type: none"> <li>Indicates [°CA] of exhaust camshaft retard angle.</li> </ul>   |   |
| EXH/V TIM B2   |          |   |   |
| INT/V SOL (B1) | %        | <ul style="list-style-type: none"> <li>The control value of the intake valve timing control solenoid valve (determined by ECM according to the input signals) is indicated.</li> <li>The advance angle becomes larger as the value increases.</li> </ul>                              |   |
| INT/V SOL (B2) |          |   |   |

# DIAGNOSIS SYSTEM (ECM)

[VK56VD FOR MEXICO]

< SYSTEM DESCRIPTION >

| Monitored item  | Unit        | Description  | Remarks |
|-----------------|-------------|--|---------|
| AIR COND RLY    | ON/OFF      | <ul style="list-style-type: none"> <li>The air conditioner relay control condition (determined by ECM according to the input signals) is indicated.</li> </ul>   | A       |
| THRTL RELAY     | ON/OFF      | <ul style="list-style-type: none"> <li>Indicates the throttle control motor relay control condition determined by the ECM according to the input signals.</li> </ul>   | EC      |
| A/F S1 HTR (B1) | %           | <ul style="list-style-type: none"> <li>Air fuel ratio (A/F) sensor 1 heater control value computed by ECM according to the input signals.</li> <li>The current flow to the heater becomes larger as the value increases.</li> </ul>  | C       |
| A/F S1 HTR (B2) |             |  |         |
| HO2S2 HTR (B1)  | ON/OFF      | <ul style="list-style-type: none"> <li>Indicates [ON/OFF] condition of heated oxygen sensor 2 heater determined by ECM according to the input signals.</li> </ul>  | D       |
| HO2S2 HTR (B2)  |             |  |         |
| ALT DUTY SIG    | ON/OFF      | <ul style="list-style-type: none"> <li>The control condition of the power generation voltage variable control (determined by ECM according to the input signals) is indicated.</li> <li>ON: Power generation voltage variable control is active.</li> <li>OFF: Power generation voltage variable control is inactive.</li> </ul> | E       |
| I/P PULLY SPD   | rpm         | <ul style="list-style-type: none"> <li>Indicates the engine speed computed from the input speed sensor signal.</li> </ul>  | F       |
| VEHICLE SPEED   | km/h or mph | <ul style="list-style-type: none"> <li>The vehicle speed computed from the vehicle speed signal sent from TCM is displayed.</li> </ul>   | G       |
| IDL A/V LEARN   | YET/CMPLT   | <ul style="list-style-type: none"> <li>Displays the condition of Idle Air Volume Learning</li> <li>YET: Idle air volume learning has not been performed yet.</li> <li>CMPLT: Idle air volume learning has already been performed successfully.</li> </ul>  | H       |
| TRVL AFTER MIL  | km or mile  | <ul style="list-style-type: none"> <li>Distance traveled while MIL is activated.</li> </ul>  | I       |
| ENG OIL TEMP    | °C or °F    | <ul style="list-style-type: none"> <li>The engine oil temperature (determined by the signal voltage of the engine oil temperature sensor) is displayed.</li> </ul>   | J       |
| VHCL SPEED SE   | km/h or mph | <ul style="list-style-type: none"> <li>The vehicle speed computed from the vehicle speed signal sent from unified meter and combination meter is displayed.</li> </ul>   | K       |
| SET VHCL SPD    | km/h or mph | <ul style="list-style-type: none"> <li>The preset vehicle speed is displayed.</li> </ul>   | L       |
| MAIN SW         | ON/OFF      | <ul style="list-style-type: none"> <li>Indicates [ON/OFF] condition from MAIN switch signal.</li> </ul>  | M       |
| CANCEL SW       | ON/OFF      | <ul style="list-style-type: none"> <li>Indicates [ON/OFF] condition from CANCEL switch signal.</li> </ul>  | N       |
| RESUME/ACC SW   | ON/OFF      | <ul style="list-style-type: none"> <li>Indicates [ON/OFF] condition from RESUME/ACCELERATE switch signal.</li> </ul>   | O       |
| SET SW          | ON/OFF      | <ul style="list-style-type: none"> <li>Indicates [ON/OFF] condition from SET/COAST switch signal.</li> </ul>   | P       |
| BRAKE SW1       | ON/OFF      | <ul style="list-style-type: none"> <li>Indicates [ON/OFF] condition from ASCD brake switch signal.</li> </ul>  |         |
| BRAKE SW2       | ON/OFF      | <ul style="list-style-type: none"> <li>Indicates [ON/OFF] condition of stop lamp switch signal.</li> </ul>   |         |
| DIST SW         | ON/OFF      | <ul style="list-style-type: none"> <li>Indicates [ON/OFF] condition from DISTANCE switch signal.</li> </ul>  |         |
| AT OD MONITOR   | ON/OFF      | <ul style="list-style-type: none"> <li>Indicates [ON/OFF] condition of A/T O/D according to the input signal from the TCM.</li> </ul>  |         |
| AT OD CANCEL    | ON/OFF      | <ul style="list-style-type: none"> <li>Indicates [ON/OFF] condition of A/T O/D cancel request signal.</li> </ul>   |         |

# DIAGNOSIS SYSTEM (ECM)

[VK56VD FOR MEXICO]

## < SYSTEM DESCRIPTION >

| Monitored item | Unit      | Description   | Remarks   |
|----------------|-----------|---|---|
| CRUISE LAMP*   | ON/OFF    | <ul style="list-style-type: none"> <li>Indicates [ON/OFF] condition of CRUISE indicator determined by the ECM according to the input signals.</li> </ul>  |   |
| SET LAMP       | ON/OFF    | <ul style="list-style-type: none"> <li>Indicates [ON/OFF] condition of SET indicator determined by the ECM according to the input signals.</li> </ul>   |   |
| EXH V/T LEARN  | YET/CMPLT | <ul style="list-style-type: none"> <li>Display the condition of Exhaust Valve Timing Control Learning<br/>YET: Exhaust Valve Timing Control Learning has not been performed yet.<br/>CMPLT: Exhaust Valve Timing Control Learning has already been performed successfully.</li> </ul> |   |
| FAN DUTY       | %         | <ul style="list-style-type: none"> <li>Indicates a command value for cooling fan. The value is calculated by ECM based on input signals.</li> </ul>   |   |
| AC EVA TEMP    | °C or °F  | <ul style="list-style-type: none"> <li>Indicates A/C evaporator temperature sent from "A/C auto amp."</li> </ul>  |   |
| AC EVA TARGET  | °C or °F  | <ul style="list-style-type: none"> <li>Indicates target A/C evaporator temperature sent from "A/C auto amp."</li> </ul>   |   |
| ALT DUTY       | %         | <ul style="list-style-type: none"> <li>Indicates the duty ratio of the power generation command value. The ratio is calculated by ECM based on the battery current sensor signal.</li> </ul>  |   |
| BAT CUR SEN    | mV        | <ul style="list-style-type: none"> <li>The signal voltage of battery current sensor is displayed.</li> </ul>  |   |
| A/F ADJ-B1     | —         | <ul style="list-style-type: none"> <li>Indicates the correction of a factor stored in ECM. The factor is calculated from the difference between the target air-fuel ratio stored in ECM and the air-fuel ratio calculated from A/F sensor 1 signal.</li> </ul>                        |   |
| A/F ADJ-B2     |           |   |   |
| TP SEN 1-B2    | V         | <ul style="list-style-type: none"> <li>The throttle position sensor signal voltage is displayed.</li> </ul>   | <ul style="list-style-type: none"> <li>TP SEN 2-B2 signal is converted by ECM internally. Thus, they differs from ECM terminal voltage signal.</li> </ul> |
| TP SEN 2-B2    |           |   |   |
| P/N POSI SW    | ON/OFF    | <ul style="list-style-type: none"> <li>Indicates [ON/OFF] condition from the park/neutral position (PNP) signal.</li> </ul>   |   |
| INT/A TEMP SE  | °C or °F  | <ul style="list-style-type: none"> <li>The intake air temperature (determined by the signal voltage of the intake air temperature sensor) is indicated.</li> </ul>  |   |
| AC PRESS SEN   | V         | <ul style="list-style-type: none"> <li>The signal voltage from the refrigerant pressure sensor is displayed.</li> </ul>   |   |
| FUEL PRESS SEN | MPa       | <ul style="list-style-type: none"> <li>Indicates the fuel rail pressure computed by ECM according to the input signals</li> </ul>   |   |
| PRESS REG      | %         | <ul style="list-style-type: none"> <li>Displays control duty of the high pressure fuel pump solenoid valve.</li> </ul>  |   |
| FUEL INJB1     | msec      | <ul style="list-style-type: none"> <li>ECM-calculated injection pulse width of the fuel injector on the Bank 1 side.</li> </ul>   |   |
| FUEL INJB2     | msec      | <ul style="list-style-type: none"> <li>ECM-calculated injection pulse width of the fuel injector on the Bank 2 side.</li> </ul>   |   |
| INT/V TIM (B1) | °CA       | <ul style="list-style-type: none"> <li>Indicates [°CA] of intake camshaft advance angle.</li> </ul>   |   |
| INT/V TIM (B2) |           |   |   |
| MAP SENSOR     | V         | <ul style="list-style-type: none"> <li>The signal voltage from the manifold absolute pressure (MAP) sensor is displayed.</li> </ul>   |   |
| VVEL LEARN     | YET/DONE  | <ul style="list-style-type: none"> <li>Display the condition of VVEL learning<br/>YET: VVEL learning has not been performed yet.<br/>DONE: VVEL learning has already been performed successfully.</li> </ul>  |   |

# DIAGNOSIS SYSTEM (ECM)

[VK56VD FOR MEXICO]

## < SYSTEM DESCRIPTION >

| Monitored item       | Unit           | Description   | Remarks |
|----------------------|----------------|---|---------|
| VVEL SEN LEARN-B1    | V              | <ul style="list-style-type: none"> <li>Indicates the VVEL learning value.</li> </ul>  |         |
| VVEL SEN LEARN-B2    |                |   |         |
| VVEL POSITION SEN-B1 | V              | <ul style="list-style-type: none"> <li>The VVEL control shaft position sensor signal voltage is displayed.</li> </ul>   |         |
| VVEL POSITION SEN-B2 |                |   |         |
| VVEL TIM-B1          | deg            | <ul style="list-style-type: none"> <li>Indicates [deg] of VVEL control shaft angle.</li> </ul>  |         |
| VVEL TIM-B2          |                |   |         |
| FPCM                 | HI/MID/LOW/OFF | <ul style="list-style-type: none"> <li>The control condition of the fuel pump control module (FPCM) (determined by ECM according to the input signals) is indicated.</li> </ul> |         |
| BAT TEMP SEN         | V              | <ul style="list-style-type: none"> <li>The signal voltage from the battery temperature sensor is displayed.</li> </ul>  |         |
| THRTL STK CNT B1*    | —              | —   |         |
| THRTL STK CNT B2*    |                |   |         |
| HO2 S2 DIAG2(B2)     | CMP/INCMP      | <ul style="list-style-type: none"> <li>These items are displayed but are not applicable to this model.</li> </ul>   |         |
| HO2 S2 DIAG2(B1)     | CMP/INCMP      |   |         |
| FUEL INJ TIMG        | deg            | <ul style="list-style-type: none"> <li>Indicates the fuel injection timing computed by ECM according to the input signals.</li> </ul>   |         |
| H/P FUEL PUMP DEG    | deg            | <ul style="list-style-type: none"> <li>Displays ECM-calculated fuel discharge position of the high pressure fuel pump.</li> </ul>   |         |
| FUEL PRES SEN V      | mV             | <ul style="list-style-type: none"> <li>The signal voltage of FRP sensor is displayed.</li> </ul>  |         |
| L/FUEL PRES SEN      | MPa            | <ul style="list-style-type: none"> <li>Displays a pressure value calculated from a low fuel pressure sensor voltage.</li> </ul>   |         |
| L/FUEL PRES SEN V    | mV             | <ul style="list-style-type: none"> <li>The signal voltage of low fuel pressure sensor is displayed.</li> </ul>  |         |
| EOP SENSOR           | mV             | <ul style="list-style-type: none"> <li>The signal voltage of EOP sensor is displayed.</li> </ul>  |         |
| ECM TEMP 1           | °C or °F       | <ul style="list-style-type: none"> <li>Displays a temperature calculated from a signal of ECM temperature sensor 1.</li> </ul>  |         |
| ECM TEMP 2           | °C or °F       | <ul style="list-style-type: none"> <li>Displays a temperature calculated from a signal of ECM temperature sensor 2.</li> </ul>  |         |
| FUEL PUMP DUTY       | %              | <ul style="list-style-type: none"> <li>The control condition of the fuel pump control module (FPCM) (determined by ECM according to the input signals) is indicated.</li> </ul> |         |

\*: The item is indicated, but not used.

**NOTE:**

Any monitored item that does not match the vehicle being diagnosed is deleted from the display automatically.

## ACTIVE TEST MODE

Test Item

# DIAGNOSIS SYSTEM (ECM)

< SYSTEM DESCRIPTION >

[VK56VD FOR MEXICO]

| TEST ITEM            | CONDITION   | JUDGMENT   | CHECK ITEM (REMEDY)   |
|----------------------|---|--|---|
| ENG COOLANT TEMP     | <ul style="list-style-type: none"> <li>Engine: Return to the original non-standard condition</li> <li>Change the engine coolant temperature using CONSULT.</li> </ul>   | If malfunctioning symptom disappears, see CHECK ITEM.  | <ul style="list-style-type: none"> <li>Harness and connectors</li> <li>Engine coolant temperature sensor</li> <li>Fuel injector</li> </ul>  |
| FUEL INJECTION       | <ul style="list-style-type: none"> <li>Engine: Return to the original non-standard condition</li> <li>Change the amount of fuel injection using CONSULT.</li> </ul>   | If malfunctioning symptom disappears, see CHECK ITEM.  | <ul style="list-style-type: none"> <li>Harness and connectors</li> <li>Fuel injector</li> <li>Air fuel ratio (A/F) sensor 1</li> </ul>  |
| FUEL/T TEMP SEN      | <ul style="list-style-type: none"> <li>Change the fuel tank temperature using CONSULT.</li> </ul>   |  |   |
| PURG VOL CONT/V      | <ul style="list-style-type: none"> <li>Engine: After warming up, run engine at 1,500 rpm.</li> <li>Change the EVAP canister purge volume control solenoid valve opening percent using CONSULT.</li> </ul>               | Engine speed changes according to the opening percent. | <ul style="list-style-type: none"> <li>Harness and connectors</li> <li>Solenoid valve</li> </ul>  |
| FAN DUTY CONTROL*    | <ul style="list-style-type: none"> <li>Ignition switch: ON</li> <li>Change duty ratio using CONSULT.</li> </ul>   | Cooling fan speed changes.                             | <ul style="list-style-type: none"> <li>Harness and connectors</li> <li>Cooling fan motor</li> <li>Cooling fan relay</li> <li>Cooling fan control module</li> <li>IPDM E/R</li> </ul>      |
| ALTERNATOR DUTY      | <ul style="list-style-type: none"> <li>Engine: Idle</li> <li>Change duty ratio using CONSULT.</li> </ul>  | Battery voltage changes.                               | <ul style="list-style-type: none"> <li>Harness and connectors</li> <li>IPDM E/R</li> <li>Alternator</li> </ul>  |
| EXH V/T ASSIGN ANGLE | <ul style="list-style-type: none"> <li>Engine: Return to the original non-standard condition</li> <li>Change exhaust valve timing using CONSULT.</li> </ul>   | If malfunctioning symptom disappears, see CHECK ITEM.  | <ul style="list-style-type: none"> <li>Harness and connectors</li> <li>Exhaust valve timing control magnet retarder</li> </ul>  |
| POWER BALANCE        | <ul style="list-style-type: none"> <li>Engine: After warming up, idle the engine.</li> <li>A/C switch OFF</li> <li>Selector lever: P or N</li> <li>Cut off each injector signal one at a time using CONSULT.</li> </ul> | Engine runs rough or stops.                            | <ul style="list-style-type: none"> <li>Harness and connectors</li> <li>Compression</li> <li>Fuel injector</li> <li>Power transistor</li> <li>Spark plug</li> <li>Ignition coil</li> </ul> |
| INT V/T ASSIGN ANGLE | <ul style="list-style-type: none"> <li>Engine: Return to the original non-standard condition</li> <li>Change intake valve timing using CONSULT.</li> </ul>  | If malfunctioning symptom disappears, see CHECK ITEM.  | <ul style="list-style-type: none"> <li>Harness and connectors</li> <li>Intake valve timing control solenoid valve</li> </ul>  |
| IGNITION TIMING      | <ul style="list-style-type: none"> <li>Engine: Return to the original non-standard condition</li> <li>Timing light: Set</li> <li>Retard the ignition timing using CONSULT.</li> </ul>                                   | If malfunctioning symptom disappears, see CHECK ITEM.  | <ul style="list-style-type: none"> <li>Perform Idle Air Volume Learning.</li> </ul>   |
| FPCM                 | <ul style="list-style-type: none"> <li>Engine: Return to the original trouble condition</li> <li>Select "LOW", "MID" and "HI" with CONSULT.</li> </ul>  | Fuel pump speed changes or stops.                      | <ul style="list-style-type: none"> <li>Harness and connectors</li> <li>Fuel pump control module (FPCM)</li> </ul>   |

\*: Leaving cooling fan OFF with CONSULT while engine is running may cause the engine to overheat.

## DTC & SRT CONFIRMATION MODE

### SRT STATUS Mode

For items whose SRT codes are set, "CMPLT" is displayed on the CONSULT screen; for items whose SRT codes are not set, "INCMP" is displayed.

### SRT WORK SUPPORT Mode

This mode enables a technician to drive a vehicle to set the SRT while monitoring the SRT status.

### DTC WORK SUPPORT Mode

# DIAGNOSIS SYSTEM (ECM)

< SYSTEM DESCRIPTION >

[VK56VD FOR MEXICO]

| Test mode | Test item                 | Corresponding DTC No. | Reference page                       |
|-----------|---------------------------|-----------------------|--------------------------------------|
| HO2S2     | HO2S2 (B1) P1146          | P0138                 | <a href="#">EC-1785, "DTC Logic"</a> |
|           | HO2S2 (B1) P1147          | P0137                 | <a href="#">EC-1779, "DTC Logic"</a> |
|           | HO2S2 (B1) P0139          | P0139                 | <a href="#">EC-1793, "DTC Logic"</a> |
|           | HO2S2 (B2) P1166          | P0158                 | <a href="#">EC-1785, "DTC Logic"</a> |
|           | HO2S2 (B2) P1167          | P0157                 | <a href="#">EC-1779, "DTC Logic"</a> |
|           | HO2S2 (B2) P0159          | P0159                 | <a href="#">EC-1793, "DTC Logic"</a> |
| A/F SEN1  | A/F SEN1 (B1) P1278/P1279 | P0133                 | <a href="#">EC-1774, "DTC Logic"</a> |
|           | A/F SEN1 (B1) P1276       | P0130                 | <a href="#">EC-1764, "DTC Logic"</a> |
|           | A/F SEN1 (B2) P1288/P1289 | P0153                 | <a href="#">EC-1774, "DTC Logic"</a> |
|           | A/F SEN1 (B2) P1286       | P0150                 | <a href="#">EC-1764, "DTC Logic"</a> |

A

EC

C

D

E

F

G

H

I

J

K

L

M

N

O

P

# ECU DIAGNOSIS INFORMATION

## ECM

### Reference Value

INFOID:000000007758178

### VALUES ON THE DIAGNOSIS TOOL

#### NOTE:

- Specification data are reference values.
- Specification data are output/input values which are detected or supplied by the ECM at the connector.
  - \* Specification data may not be directly related to their components signals/values/operations.
    - i.e. Adjust ignition timing with a timing light before monitoring IGN TIMING, because the monitor may show the specification data in spite of the ignition timing not being adjusted to the specification data. This IGN TIMING monitors the data calculated by the ECM according to the signals input from the camshaft position sensor and other ignition timing related sensors.

#### CONSULT MONITOR ITEM

| Monitor Item    | Condition  |                                       | Values/Status                                      |
|-----------------|--|---------------------------------------|--|
| ENG SPEED       | • Run engine and compare CONSULT value with the tachometer indication.   |                                       | Almost the same speed as the tachometer indication |
| MAS A/F SE-B1   | See <a href="#">EC-1700, "Description"</a> .   |                                       |  |
| MAS A/F SE-B2   | See <a href="#">EC-1700, "Description"</a> .   |                                       |  |
| B/FUEL SCHDL    | See <a href="#">EC-1700, "Description"</a> .   |                                       |  |
| A/F ALPHA-B1    | See <a href="#">EC-1700, "Description"</a> .   |                                       |  |
| A/F ALPHA-B2    | See <a href="#">EC-1700, "Description"</a> .   |                                       |  |
| COOLAN TEMP/S   | • Ignition switch: ON  |                                       | Indicates engine coolant temperature               |
| A/F SEN1 (B1)   | • Engine: After warming up   | Maintaining engine speed at 2,000 rpm | Fluctuates around 1.5 V                            |
| A/F SEN1 (B2)   | • Engine: After warming up   | Maintaining engine speed at 2,000 rpm | Fluctuates around 1.5 V                            |
| HO2S2 (B1)      | <ul style="list-style-type: none"> <li>• Revving engine from idle up to 3,000 rpm quickly after the following conditions are met.</li> <li>- Engine: After warming up</li> <li>- After keeping engine speed between 3,500 and 4,000 rpm for 1 minute and at idle for 1 minute under no load</li> </ul> |                                       | 0 - 0.3 V ↔ Approx. 0.6 - 1.0 V                    |
| HO2S2 (B2)      | <ul style="list-style-type: none"> <li>• Revving engine from idle up to 3,000 rpm quickly after the following conditions are met.</li> <li>- Engine: After warming up</li> <li>- After keeping engine speed between 3,500 and 4,000 rpm for 1 minute and at idle for 1 minute under no load</li> </ul> |                                       | 0 - 0.3 V ↔ Approx. 0.6 - 1.0 V                    |
| HO2S2 MNTR (B1) | <ul style="list-style-type: none"> <li>• Revving engine from idle up to 3,000 rpm quickly after the following conditions are met.</li> <li>- Engine: After warming up</li> <li>- After keeping engine speed between 3,500 and 4,000 rpm for 1 minute and at idle for 1 minute under no load</li> </ul> |                                       | LEAN ↔ RICH  |
| HO2S2 MNTR (B2) | <ul style="list-style-type: none"> <li>• Revving engine from idle up to 3,000 rpm quickly after the following conditions are met.</li> <li>- Engine: After warming up</li> <li>- After keeping engine speed between 3,500 and 4,000 rpm for 1 minute and at idle for 1 minute under no load</li> </ul> |                                       | LEAN ↔ RICH  |
| VHCL SPEED SE   | • Turn drive wheels and compare CONSULT value with the speedometer indication.   |                                       | Almost the same speed as speedometer indication    |
| BATTERY VOLT    | • Ignition switch: ON (Engine stopped)   |                                       | 11 - 14 V  |
| ACCEL SEN 1     | • Ignition switch: ON (Engine stopped)   | Accelerator pedal: Fully released     | 0.45 - 1.0 V                                       |
|                 |  | Accelerator pedal: Fully depressed    | 4.4 - 4.8 V  |
| ACCEL SEN 2*1   | • Ignition switch: ON (Engine stopped)   | Accelerator pedal: Fully released     | 0.45 - 1.0 V                                       |
|                 |  | Accelerator pedal: Fully depressed    | 4.3 - 4.8 V  |



# ECM

< ECU DIAGNOSIS INFORMATION >

[VK56VD FOR MEXICO]

| Monitor Item  | Condition   | Values/Status   |
|---------------|---|---|
| TP SEN 1-B1   | • Ignition switch: ON (Engine stopped)<br>• Selector lever: D position                            | Accelerator pedal: Fully released<br>More than 0.36 V                         |
|               |   | Accelerator pedal: Fully depressed<br>Less than 4.75 V                        |
| TP SEN 2-B1*1 | • Ignition switch: ON (Engine stopped)<br>• Selector lever: D position                            | Accelerator pedal: Fully released<br>More than 0.36 V                         |
|               |   | Accelerator pedal: Fully depressed<br>Less than 4.75 V                        |
| FUEL T/TMP SE | • Ignition switch: ON   | Indicates fuel tank temperature   |
| FUEL LEVEL SE | • Ignition switch: ON   | Depending on fuel level of fuel tank  |
| START SIGNAL  | • Ignition switch: ON → START → ON  | OFF → ON → OFF  |
| CLSD THL POS  | • Ignition switch: ON (Engine stopped)  | Accelerator pedal: Fully released<br>ON                                       |
|               |   | Accelerator pedal: Slightly depressed<br>OFF                                  |
| AIR COND SIG  | • Engine: After warming up, idle the engine   | Air conditioner switch: OFF<br>OFF  |
|               |   | Air conditioner switch: ON (Compressor operates.)<br>ON                       |
| PW/ST SIGNAL  | • Engine: After warming up, idle the engine   | Steering wheel: Not being turned<br>OFF                                       |
|               |   | Steering wheel: Being turned<br>ON  |
| LOAD SIGNAL   | • Ignition switch: ON   | Rear window defogger switch: ON and/or<br>Lighting switch: 2nd position<br>ON |
|               |   | Rear window defogger switch and lighting switch: OFF<br>OFF                   |
| IGNITION SW   | • Ignition switch: ON → OFF → ON  | ON → OFF → ON   |
| HEATER FAN SW | • Engine: After warming up, idle the engine   | Blower fan switch: ON<br>ON   |
|               |   | Blower fan switch: OFF<br>OFF   |
| BRAKE SW      | • Ignition switch: ON   | Brake pedal: Fully released<br>OFF  |
|               |   | Brake pedal: Slightly depressed<br>ON   |
| INJ PULSE-B1  | • Engine: After warming up<br>• Selector lever: P or N position<br>• A/C switch: OFF<br>• No load | Idle<br>2.0 - 3.0 msec  |
|               |   | 2,000 rpm<br>1.9 - 2.9 msec   |
| INJ PULSE-B2  | • Engine: After warming up<br>• Selector lever: P or N position<br>• A/C switch: OFF<br>• No load | Idle<br>2.0 - 3.0 msec  |
|               |   | 2,000 rpm<br>1.9 - 2.9 msec   |
| IGN TIMING    | • Engine: After warming up<br>• Selector lever: P or N position<br>• A/C switch: OFF<br>• No load | Idle<br>1 - 4°BTDC  |
|               |   | 2,000 rpm<br>25 - 45°BTDC   |
| COMBUSTION    | —   | These items are displayed but are not applicable to this model.               |
| CAL/LD VALUE  | • Engine: After warming up<br>• Selector lever: P or N position<br>• A/C switch: OFF<br>• No load | Idle<br>5 - 35%   |
|               |   | 2,500 rpm<br>5 - 35%  |
| MASS AIRFLOW  | • Engine: After warming up<br>• Selector lever: P or N position<br>• A/C switch: OFF<br>• No load | Idle<br>2.0 - 6.0 g/s   |
|               |   | 2,500 rpm<br>7.0 - 20.0 g/s   |

A

EC

C

D

E

F

G

H

I

J

K

L

M

N

O

P

# ECM

< ECU DIAGNOSIS INFORMATION >

[VK56VD FOR MEXICO]

| Monitor Item    | Condition   | Values/Status                                       |
|-----------------|---|---|
| PURG VOL C/V    | <ul style="list-style-type: none"> <li>Engine: After warming up</li> <li>Selector lever: P or N position</li> <li>A/C switch: OFF</li> <li>No load</li> </ul> Idle<br>(Accelerator pedal: Not depressed even slightly, after engine starting.)  | 0%  |
|                 | 2,000 rpm   | 5%  |
| EXH/V TIM B1    | <ul style="list-style-type: none"> <li>Engine: After warming up</li> <li>Selector lever: P or N position</li> <li>A/C switch: OFF</li> <li>No load</li> </ul> Idle  | -5° - 5°C   |
|                 | Around 2,500 rpm while the engine speed is rising   | Approx. 0 - 30°C                                    |
| EXH/V TIM B2    | <ul style="list-style-type: none"> <li>Engine: After warming up</li> <li>Selector lever: P or N position</li> <li>A/C switch: OFF</li> <li>No load</li> </ul> Idle  | -5 - 5°C  |
|                 | Around 2,500 rpm while the engine speed is rising   | Approx. 0 - 30°C                                    |
| INT/V SOL (B1)  | <ul style="list-style-type: none"> <li>Engine: After warming up</li> <li>Selector lever: P or N position</li> <li>A/C switch: OFF</li> <li>No load</li> </ul> Idle  | 0 - 2%  |
|                 | 2,000 rpm   | Approx. 0 - 50%                                     |
| INT/V SOL (B2)  | <ul style="list-style-type: none"> <li>Engine: After warming up</li> <li>Selector lever: P or N position</li> <li>A/C switch: OFF</li> <li>No load</li> </ul> Idle  | 0 - 2%  |
|                 | 2,000 rpm   | Approx. 0 - 50%                                     |
| AIR COND RLY    | <ul style="list-style-type: none"> <li>Engine: After warming up, idle the engine</li> </ul> A/C switch: OFF   | OFF   |
|                 | A/C switch: ON<br>(Compressor operates)   | ON  |
| THRTL RELAY     | <ul style="list-style-type: none"> <li>Ignition switch: ON</li> </ul>   | ON  |
| A/F S1 HTR (B1) | <ul style="list-style-type: none"> <li>Engine: After warming up, idle the engine<br/>(More than 140 seconds after starting engine)</li> </ul>   | 4 - 100%  |
| A/F S1 HTR (B2) | <ul style="list-style-type: none"> <li>Engine: After warming up, idle the engine<br/>(More than 140 seconds after starting engine)</li> </ul>   | 4 - 100%  |
| HO2S2 HTR (B1)  | <ul style="list-style-type: none"> <li>Engine speed: Below 3,600 rpm after the following conditions are met.               <ul style="list-style-type: none"> <li>Engine: After warming up</li> <li>Keeping the engine speed between 3,500 and 4,000 rpm for 1 minute and at idle for 1 minute under no load</li> </ul> </li> </ul> | ON  |
|                 | <ul style="list-style-type: none"> <li>Engine speed: Above 3,600 rpm</li> </ul>   | OFF   |
| HO2S2 HTR (B2)  | <ul style="list-style-type: none"> <li>Engine speed: Below 3,600 rpm after the following conditions are met.               <ul style="list-style-type: none"> <li>Engine: After warming up</li> <li>Keeping the engine speed between 3,500 and 4,000 rpm for 1 minute and at idle for 1 minute under no load</li> </ul> </li> </ul> | ON  |
|                 | <ul style="list-style-type: none"> <li>Engine speed: Above 3,600 rpm</li> </ul>   | OFF   |
| ALT DUTY SIG    | <ul style="list-style-type: none"> <li>Power generation voltage variable control: Operating</li> </ul>  | ON  |
|                 | <ul style="list-style-type: none"> <li>Power generation voltage variable control: Not operating</li> </ul>  | OFF   |
| I/P PULLY SPD   | <ul style="list-style-type: none"> <li>Vehicle speed: More than 20 km/h (12 MPH)</li> </ul>   | Almost the same speed as the tachometer indication  |
| VEHICLE SPEED   | <ul style="list-style-type: none"> <li>Turn drive wheels and compare CONSULT value with the speedometer indication.</li> </ul>  | Almost the same speed as the speedometer indication |
| IDL A/V LEARN   | <ul style="list-style-type: none"> <li>Engine: Running</li> </ul> Idle air volume learning has not been performed yet.  | YET   |
|                 | Idle air volume learning has already been performed successfully.   | CMPLT   |
| TRVL AFTER MIL  | <ul style="list-style-type: none"> <li>Ignition switch: ON</li> </ul> Vehicle has traveled after MIL has illuminated.   | 0 - 65,535 km<br>(0 - 40,723 miles)                 |
| ENG OIL TEMP    | <ul style="list-style-type: none"> <li>Engine: After warming up</li> </ul>  | More than 70°C (158°F)                              |
| VHCL SPEED SE   | <ul style="list-style-type: none"> <li>Turn drive wheels and compare CONSULT value with the speedometer indication.</li> </ul>  | Almost the same speed as the speedometer indication |

# ECM

## < ECU DIAGNOSIS INFORMATION >

**[VK56VD FOR MEXICO]**

| Monitor Item                         | Condition   |   | Values/Status   |
|--------------------------------------|---|---|---|
| SET VHCL SPD                         | • Engine: Running   | ASCD: Operating   | The preset vehicle speed is displayed                                 |
| MAIN SW                              | • Ignition switch: ON   | MAIN switch: Pressed  | ON  |
|                                      |   | MAIN switch: Released   | OFF   |
| CANCEL SW                            | • Ignition switch: ON   | CANCEL switch: Pressed  | ON  |
|                                      |   | CANCEL switch: Released   | OFF   |
| RESUME/ACC SW                        | • Ignition switch: ON   | RESUME/ACCELERATE switch: Pressed                                 | ON  |
|                                      |   | RESUME/ACCELERATE switch: Released                                | OFF   |
| SET SW                               | • Ignition switch: ON   | SET/COAST switch: Pressed   | ON  |
|                                      |   | SET/COAST switch: Released  | OFF   |
| BRAKE SW1<br>(ASCD/ICC brake switch) | • Ignition switch: ON   | Brake pedal: Fully released                                       | ON  |
|                                      |   | Brake pedal: Slightly depressed                                   | OFF   |
| BRAKE SW2<br>(Stop lamp switch)      | • Ignition switch: ON   | Brake pedal: Fully released                                       | OFF   |
|                                      |   | Brake pedal: Slightly depressed                                   | ON  |
| DIST SW                              | • Ignition switch: ON   | DISTANCE switch: Pressed  | ON  |
|                                      |   | DISTANCE switch: Released   | OFF   |
| AT OD MONITOR                        | • Ignition switch: ON   |   | OFF   |
| AT OD CANCEL                         | • Ignition switch: ON   |   | OFF   |
| CRUISE LAMP                          | • Ignition switch: ON   | MAIN switch: Pressed at the 1st time → at the 2nd time            | ON → OFF  |
| SET LAMP                             | • MAIN switch: ON<br>• When vehicle speed is within ICC operating range.  | ICC: Operating  | ON  |
|                                      |   | ICC: Not operating  | OFF   |
| EXH V/T LEARN                        | • Engine: Running   | Exhaust Valve Timing Control Learning has not been performed yet. | YET   |
|                                      |   | Exhaust Valve Timing Control Learning has not been performed yet. | CMPLT   |
| FAN DUTY                             | • Engine: Running   |   | 0 - 100%  |
| AC EVA TEMP                          | • Engine: Running   |   | Indicates A/C evaporator temperature sent from "A/C auto amp."        |
| AC EVA TARGET                        | • Engine: Running   |   | Indicates target A/C evaporator temperature sent from "A/C auto amp." |
| ALT DUTY                             | • Engine: Idle  |   | 0 - 80%   |
| BAT CUR SEN                          | • Engine speed: Idle<br>• Battery: Fully charged*2<br>• Selector lever: P or N position<br>• A/C switch: OFF<br>• No load |   | Approx. 2,600 - 3,500 mV  |
| A/F ADJ-B1                           | • Engine: Running   |   | -0.330 - 0.330  |
| A/F ADJ-B2                           | • Engine: Running   |   | -0.330 - 0.330  |
| TP SEN 1-B2                          | • Ignition switch: ON (Engine stopped)<br>• Selector lever: D position  | Accelerator pedal: Fully released                                 | More than 0.36 V  |
|                                      |   | Accelerator pedal: Fully depressed                                | Less than 4.75 V  |
| TP SEN 2-B2*1                        | • Ignition switch: ON (Engine stopped)<br>• Selector lever: D position  | Accelerator pedal: Fully released                                 | More than 0.36 V  |
|                                      |   | Accelerator pedal: Fully depressed                                | Less than 4.75 V  |

A

EC

C

D

E

F

G

H

I

J

K

L

M

N

O

P

# ECM

## < ECU DIAGNOSIS INFORMATION >

**[VK56VD FOR MEXICO]**

| Monitor Item         | Condition   | Values/Status  |
|----------------------|---|--|
| P/N POSI SW          | • Ignition switch: ON<br>Selector lever: P or N   | ON   |
|                      | Selector lever: Except above position   | OFF  |
| INT/A TEMP SE        | • Ignition switch: ON   | Indicates intake air temperature                               |
| AC PRESS SEN         | • Engine: Idle<br>• Both A/C switch and blower fan switch: ON (Compressor operates)                                   | 1.0 - 4.0 V  |
| FUEL PRES SEN        | • Engine: After warming up<br>• Selector lever: P or N position<br>• A/C switch: OFF<br>• No load<br>Idle             | Approx. 2.74 MPa   |
|                      | 2,000 rpm   | Approx. 3.0 MPa  |
| PRESS REG            | • Engine: After warming up<br>• Selector lever: P or N position<br>• A/C switch: OFF<br>• No load<br>Idle             | Approx. 82.5%  |
|                      | 2,000 rpm   | Approx. 90.0%  |
| FUEL INJ B1          | • Engine: After warming up<br>• Selector lever: P or N position<br>• A/C switch: OFF<br>• No load<br>Idle             | Approx. 1.4 msec   |
|                      | 2,000 rpm   | Approx. 1.0 msec   |
| FUEL INJ B2          | • Engine: After warming up<br>• Selector lever: P or N position<br>• A/C switch: OFF<br>• No load<br>Idle             | Approx. 1.4 msec   |
|                      | 2,000 rpm   | Approx. 1.0 msec   |
| INT/V TIM (B1)       | • Engine: After warming up<br>• Selector lever: P or N position<br>• A/C switch: OFF<br>• No load<br>Idle             | -5 - 5°C   |
|                      | 2,000 rpm   | Approx. 0 - 30°C   |
| INT/V TIM (B2)       | • Engine: After warming up<br>• Selector lever: P or N position<br>• A/C switch: OFF<br>• No load<br>Idle             | -5 - 5°C   |
|                      | 2,000 rpm   | Approx. 0 - 30°C   |
| VVEL LEARN           | • Ignition switch: OFF → ON (After warming up)  | VVEL learning has not been performed yet.<br>YET               |
|                      |   | VVEL learning has already been performed successfully.<br>DONE |
| MAP SENSOR           | • Engine: After warming up<br>• Selector lever: P or N position<br>• A/C switch: OFF<br>• No load<br>Idle             | Approx. 1.0 V  |
|                      | 2,000 rpm   | Approx. 1.35 V   |
| EVAP LEAK DIAG       | • Ignition switch: ON   | Indicates the condition of EVAP leak diagnosis.                |
| EVAP DIAG READY      | • Ignition switch: ON   | Indicates the ready condition of EVAP leak diagnosis.          |
| VVEL SEN LEARN-B1    | • VVEL learning has already been performed successfully   | Approx. 0.30 - 0.80 V  |
| VVEL SEN LEARN-B2    | • VVEL learning has already been performed successfully   | Approx. 0.30 - 0.80 V  |
| VVEL POSITION SEN-B1 | • Engine: After warming up<br>• Selector lever: P or N position<br>• A/C switch: OFF<br>• No load<br>Idle             | Approx. 0.25 - 1.50 V  |
|                      | When revving engine up to 2,000 rpm quickly   | Approx. 0.25 - 4.75 V  |
| VVEL POSITION SEN-B2 | • Engine: After warming up<br>• Selector lever: P or N position<br>• Air conditioner switch: OFF<br>• No load<br>Idle | Approx. 0.25 - 1.50 V  |
|                      | When revving engine up to 2,000 rpm quickly   | Approx. 0.25 - 4.75 V  |
| VVEL TIM-B1          | • Engine: After warming up<br>• Selector lever: P or N position<br>• A/C switch: OFF<br>• No load<br>Idle             | Approx. 0 - 23 deg   |
|                      | When revving engine up to 2,000 rpm quickly   | Approx. 0 - 90 deg   |

# ECM

## < ECU DIAGNOSIS INFORMATION >

**[VK56VD FOR MEXICO]**

| Monitor Item      | Condition  | Values/Status   |
|-------------------|--|---|
| VVEL TIM-B2       | <ul style="list-style-type: none"> <li>Engine: After warming up</li> <li>Selector lever: P or N position</li> <li>A/C switch: OFF</li> <li>No load</li> </ul>                    | Idle<br>Approx. 0 - 23 deg  |
|                   | When revving engine up to 2,000 rpm quickly  | Approx. 0 - 90 deg  |
| FPCM              | <ul style="list-style-type: none"> <li>Engine: After warming up</li> <li>Selector lever: P or N position</li> <li>A/C switch: OFF</li> <li>No load</li> </ul>                    | <ul style="list-style-type: none"> <li>Engine: Cranking</li> </ul> HI   |
|                   |  | <ul style="list-style-type: none"> <li>Revvng engine from idle to 4,000 rpm quickly</li> </ul> MID                            |
|                   |  | <ul style="list-style-type: none"> <li>Engine: Idle</li> <li>Engine coolant temperature: More than 10°C (50°F)</li> </ul> LOW |
| BAT TEMP SEN      | <ul style="list-style-type: none"> <li>Engine: After warming up</li> <li>Selector lever: P or N position</li> <li>A/C switch: OFF</li> <li>No load</li> </ul> Idle               | Indicates the temperature around the battery.   |
| THRTL STK CNT B1  | Not used.  | —   |
| THRTL STK CNT B2  |  |   |
| HO2 S2 DIAG2(B2)  | <ul style="list-style-type: none"> <li>Engine: After warming up</li> <li>Selector lever: P or N position</li> <li>A/C switch: OFF</li> <li>No load</li> </ul>                    | <ul style="list-style-type: none"> <li>DTC P0139 self-diagnosis (slow response) is incomplete.</li> </ul> IMCMP               |
|                   |  | <ul style="list-style-type: none"> <li>DTC P0139 self-diagnosis (slow response) is complete.</li> </ul> CMPLT                 |
| HO2 S2 DIAG2(B1)  | <ul style="list-style-type: none"> <li>Engine: After warming up</li> <li>Selector lever: P or N position</li> <li>A/C switch: OFF</li> <li>No load</li> </ul>                    | <ul style="list-style-type: none"> <li>DTC P0139 self-diagnosis (slow response) is incomplete.</li> </ul> IMCMP               |
|                   |  | <ul style="list-style-type: none"> <li>DTC P0139 self-diagnosis (slow response) is complete.</li> </ul> CMPLT                 |
| FUEL INJ TIMG     | <ul style="list-style-type: none"> <li>Engine: After warming up</li> <li>Selector lever: P or N position</li> <li>A/C switch: OFF</li> <li>No load</li> </ul>                    | Idle<br>Approx. 16 deg  |
|                   |  | 2,000 rpm<br>Approx. -170 deg   |
| H/P FUEL PUMP DEG | <ul style="list-style-type: none"> <li>Engine: After warming up</li> <li>Selector lever: P or N position</li> <li>A/C switch: OFF</li> <li>No load</li> </ul>                    | Idle<br>Approx. 211.0 deg   |
|                   |  | 2,000 rpm<br>Approx. 206.0 deg  |
| FUEL PRES SEN V   | <ul style="list-style-type: none"> <li>Engine: After warming up</li> <li>Selector lever: P or N position</li> <li>A/C switch: OFF</li> <li>No load</li> </ul>                    | Idle<br>Approx. 820 - 1,220 mV  |
|                   |  | Revvng engine from idle to 4,000 rpm quickly<br>Approx. 820 - 3,060 mV  |
| L/FUEL PRES SEN   | <ul style="list-style-type: none"> <li>Engine: After warming up</li> <li>Selector lever: P or N position</li> <li>A/C switch: OFF</li> <li>No load</li> </ul>                    | Idle<br>Approx. 0.45 MPa  |
|                   |  | 2,000 rpm<br>Approx. 0.45 MPa   |
| L/FUEL PRES SEN V | <ul style="list-style-type: none"> <li>Engine: After warming up</li> <li>Selector lever: P or N position</li> <li>A/C switch: OFF</li> <li>No load</li> </ul>                    | Idle<br>Approx. 3250 mV   |
|                   |  | 3,000 rpm<br>Approx. 3100 mV  |
| EOP SENSOR        | <ul style="list-style-type: none"> <li>Engine: After warming up</li> <li>Selector lever: P or N position</li> <li>A/C switch: OFF</li> <li>No load</li> </ul>                    | Idle<br>Approx. 1450 mV   |
|                   |  | 2,000 rpm<br>Approx. 2850 mV  |
| ECM TEMP 1        | <ul style="list-style-type: none"> <li>Engine: After warming up</li> <li>Selector lever: P or N position</li> <li>A/C switch: OFF</li> <li>No load</li> </ul> Idle               | Indicates the temperature of ECM internal circuit 1.  |
| ECM TEMP 2        | <ul style="list-style-type: none"> <li>Engine: After warming up</li> <li>Selector lever: P or N position</li> <li>A/C switch: OFF</li> <li>No load</li> </ul> Idle               | Indicates the temperature of ECM internal circuit 2.  |
| FUEL PUMP DUTY    | <ul style="list-style-type: none"> <li>Engine: After warming up</li> <li>Shift lever: P or N</li> <li>Air conditioner switch: OFF</li> <li>No load</li> </ul> Engine speed: Idle | 30 - 40%  |

A

EC

C

D

E

F

G

H

I

J

K

L

M

N

O

P

\*1: Accelerator pedal position sensor 2 signal and throttle position sensor 2 signal are converted by ECM internally. Thus, they differ from ECM terminals voltage signal.

\*2: Before measuring the terminal voltage, confirm that the battery is fully charged. Refer to [PG-135, "How to Handle Battery"](#).

TERMINAL LAYOUT

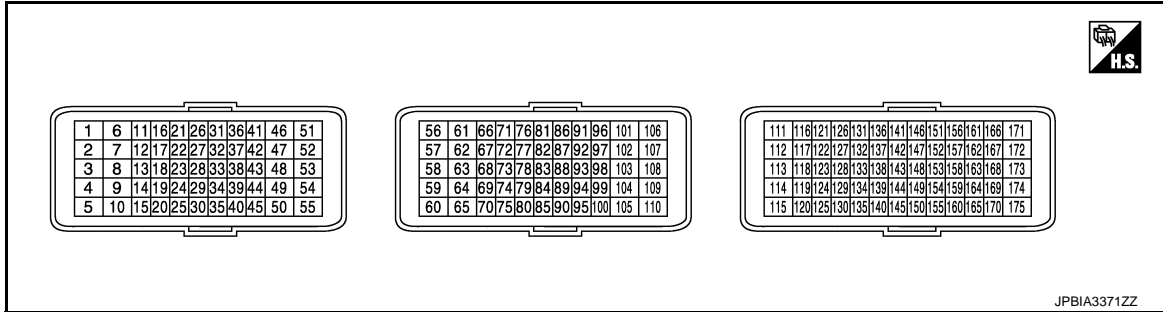

PHYSICAL VALUES

NOTE:

- Specification data are reference values and are measured between each terminals.
- Pulse signal is measured by CONSULT.

| Terminal No.<br>(Wire color) |            | Description  |                  | Condition  | Value<br>(Approx.)   |
|------------------------------|------------|--|------------------|--|--|
| +                            | -          | Signal name  | Input/<br>Output |  |  |
| 1<br>(Y)<br>2<br>(L)         | 175<br>(B) | Fuel injector No. 8 (HI)                             | Output           | [Engine is running]<br>• Warm-up condition<br>• Idle speed<br><b>NOTE:</b><br>The pulse cycle changes depending on rpm at idle | BATTERY VOLTAGE<br>(11 - 14 V)★<br>100mSec/div<br><br>20V/div<br>JPBIA3345ZZ |
|                              |            | Fuel injector No. 5 (HI)                             |                  | [Engine is running]<br>• Warm-up condition<br>• Engine speed: 2,000 rpm  | BATTERY VOLTAGE<br>(11 - 14 V)★<br>100mSec/div<br><br>20V/div<br>JPBIA3347ZZ |
| 3<br>(Y)<br>4<br>(L)         | 175<br>(B) | Fuel injector No. 3 (LO)<br>Fuel injector No. 2 (LO) | Input            | [Engine is running]<br>• Warm-up condition<br>• Idle speed<br><b>NOTE:</b><br>The pulse cycle changes depending on rpm at idle | BATTERY VOLTAGE<br>(11 - 14 V)★<br>50mSec/div<br><br>2V/div<br>JPBIA3355ZZ   |

# ECM

< ECU DIAGNOSIS INFORMATION >

[VK56VD FOR MEXICO]

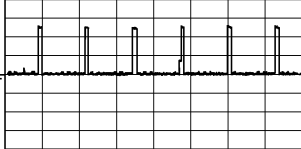
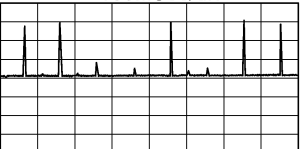
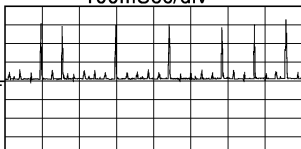
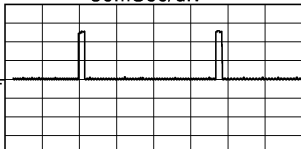
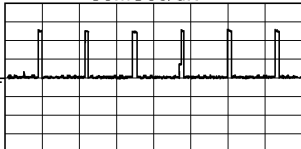
| Terminal No.<br>(Wire color) |            | Description  |                  | Condition  | Value<br>(Approx.)   |
|------------------------------|------------|--|------------------|--|--|
| +                            | -          | Signal name  | Input/<br>Output |  |  |
|                              |            |  |                  | [Engine is running]<br>• Warm-up condition<br>• Engine speed: 2,000 rpm  | BATTERY VOLTAGE<br>(11 - 14 V)★<br><br>50mSec/div<br><br>2V/div<br><small>JPBIA3356ZZ</small>     |
| 5<br>(B)                     | —          | ECM ground   | —                | —  | —  |
| 6<br>(BR)<br>7<br>(B/W)      | 175<br>(B) | Fuel injector No. 3 (HI)<br>Fuel injector No. 2 (HI) | Output           | [Engine is running]<br>• Warm-up condition<br>• Idle speed<br><b>NOTE:</b><br>The pulse cycle changes depending on rpm at idle | BATTERY VOLTAGE<br>(11 - 14 V)★<br><br>100mSec/div<br><br>20V/div<br><small>JPBIA3345ZZ</small>   |
|                              |            |  |                  | [Engine is running]<br>• Warm-up condition<br>• Engine speed: 2,000 rpm  | BATTERY VOLTAGE<br>(11 - 14 V)★<br><br>100mSec/div<br><br>20V/div<br><small>JPBIA3347ZZ</small> |
| 8<br>(BR)<br>9<br>(B/W)      | 175<br>(B) | Fuel injector No. 8 (LO)<br>Fuel injector No. 5 (LO) | Input            | [Engine is running]<br>• Warm-up condition<br>• Idle speed<br><b>NOTE:</b><br>The pulse cycle changes depending on rpm at idle | BATTERY VOLTAGE<br>(11 - 14 V)★<br><br>50mSec/div<br><br>2V/div<br><small>JPBIA3355ZZ</small>   |
|                              |            |  |                  | [Engine is running]<br>• Warm-up condition<br>• Engine speed: 2,000 rpm  | BATTERY VOLTAGE<br>(11 - 14 V)★<br><br>50mSec/div<br><br>2V/div<br><small>JPBIA3356ZZ</small>   |
| 10<br>(GR)                   | —          | ECM ground   | —                | —  | —  |
| 11<br>(LG)                   | 175<br>(B) | PNP switch   | Input            | [Ignition switch: ON]<br>• Selector lever: P or N position   | BATTERY VOLTAGE<br>(11 - 14 V)   |
|                              |            |  |                  | [Ignition switch: ON]<br>• Selector lever: Except above position   | 0 V  |

A  
EC  
C  
D  
E  
F  
G  
H  
I  
J  
K  
L  
M  
N  
O  
P

# ECM

< ECU DIAGNOSIS INFORMATION >

[VK56VD FOR MEXICO]

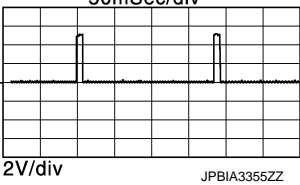
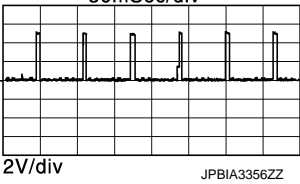
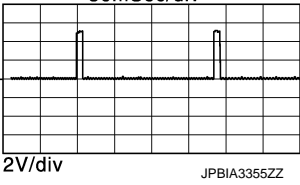
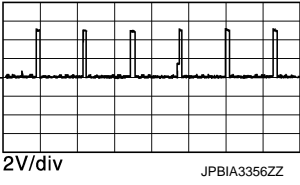
| Terminal No.<br>(Wire color)                      |            | Description  |                  | Condition  | Value<br>(Approx.)   |
|---|------------|--|------------------|--|--|
| +   | -          | Signal name  | Input/<br>Output |  |  |
| 12<br>(O)<br>13<br>(L)<br>14<br>(G)<br>15<br>(R)  | 175<br>(B) | Ignition signal No. 1<br>Ignition signal No. 2<br>Ignition signal No. 3<br>Ignition signal No. 4 | Input            | [Engine is running]<br>• Warm-up condition<br>• Idle speed<br><b>NOTE:</b><br>The pulse cycle changes depending on rpm at idle | 0 - 0.2 V★<br><br>JPBIA3355ZZ     |
|   |            |  |                  | [Engine is running]<br>• Warm-up condition<br>• Engine speed: 2,000 rpm  | 0.1 - 0.4 V★<br><br>JPBIA3356ZZ   |
| 17<br>(LG)<br>18<br>(V)<br>19<br>(L)<br>20<br>(G) | 175<br>(B) | Ignition signal No. 5<br>Ignition signal No. 6<br>Ignition signal No. 7<br>Ignition signal No. 8 | Input            | [Engine is running]<br>• Warm-up condition<br>• Idle speed<br><b>NOTE:</b><br>The pulse cycle changes depending on rpm at idle | 0 - 0.2 V★<br><br>JPBIA3355ZZ    |
|   |            |  |                  | [Engine is running]<br>• Warm-up condition<br>• Engine speed: 2,000 rpm  | 0.1 - 0.4 V★<br><br>JPBIA3356ZZ |
| 21<br>(R)   | 25<br>(P)  | Intake air temperature sensor  | Input            | [Engine is running]  | 0 - 4.8 V<br>Output voltage varies with intake air temperature.  |
| 22<br>(GR) <sup>*1</sup><br>(B) <sup>*2</sup>     | 25<br>(P)  | Mass air flow sensor (bank 1)  | Input            | [Engine is running]<br>• Warm-up condition<br>• Idle speed   | 0.95 - 1.35 V  |
|   |            |  |                  | [Engine is running]<br>• Warm-up condition<br>• Engine speed: 2,500 rpm  | 1.3 - 1.7 V  |



# ECM

< ECU DIAGNOSIS INFORMATION >

[VK56VD FOR MEXICO]

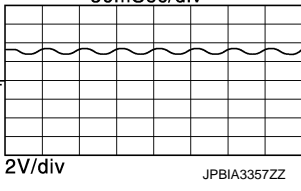
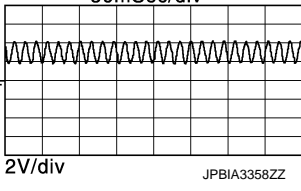
| Terminal No.<br>(Wire color)                  |           | Description  |                  | Condition  | Value<br>(Approx.)   |
|---|-----------|--|------------------|--|--|
| +   | -         | Signal name  | Input/<br>Output |  |  |
| 23<br>(B)                                     | 45<br>(V) | Low fuel pressure sensor   | Input            | [Engine is running]<br>• Warm-up condition<br>• Idle speed                                       | 2.4 - 3.6 V<br> |
|   |           |  |                  | [Engine is running]<br>• Warm-up condition<br>• Engine speed: 2,000 rpm                          | 2.4 - 3.6 V<br> |
| 24<br>(B) <sup>*1</sup><br>(BR) <sup>*2</sup> | 30<br>(O) | Mass air flow sensor (bank 2)  | Input            | [Engine is running]<br>• Warm-up condition<br>• Idle speed                                       | 0.95 - 1.35 V  |
|   |           |  |                  | [Engine is running]<br>• Warm-up condition<br>• Engine speed: 2,500 rpm                          | 1.3 - 1.7 V  |
| 25<br>(P)                                     | —         | Sensor ground<br>[Mass air flow sensor (bank 1)/<br>Intake air temperature sensor]   | —                | —  | —  |
| 27<br>(G)                                     | 45<br>(V) | Sensor power supply<br>(Power steering pressure sensor/<br>Low fuel pressure sensor) | —                | [Ignition switch: ON]  | 5 V  |
| 28<br>(W)                                     | 40<br>(B) | Sensor power supply<br>(Fuel rail pressure sensor/<br>Engine oil pressure sensor)    | —                | [Ignition switch: ON]  | 5 V  |
| 29<br>(W)                                     | 35<br>(—) | Knock sensor (bank 1)  | Input            | [Engine is running]<br>• Idle speed  | 2.5 V <sup>*3</sup>  |
| 30<br>(O)                                     | —         | Sensor ground<br>[Mass air flow sensor (bank 2)]                                     | —                | —  | —  |
| 31<br>(G)                                     | 40<br>(B) | Fuel rail pressure sensor  | Input            | [Engine is running]<br>• Warm-up condition<br>• Idle speed                                       | 0.82 - 1.22 V  |
|   |           |  |                  | [Engine is running]<br>• Warm-up condition<br>• Revving engine from idle to 4,000<br>rpm quickly | 0.82 - 3.06 V  |
| 32<br>(Y)                                     | 40<br>(B) | Engine coolant temperature<br>sensor   | Input            | [Engine is running]  | 0 - 4.8 V<br>Output voltage varies with engine<br>coolant temperature.                             |
| 33<br>(GR)                                    | 35<br>(—) | Knock sensor (bank 2)  | Input            | [Engine is running]<br>• Idle speed  | 2.5 V <sup>*3</sup>  |
| 35<br>(—)                                     | —         | Sensor ground<br>(Knock sensor)  | —                | —  | —  |
| 39<br>(LG)                                    | 45<br>(V) | Power steering pressure sensor   | Input            | [Engine is running]<br>• Steering wheel: Being turned  | 0.5 - 4.5 V  |
|   |           |  |                  | [Engine is running]<br>• Steering wheel: Not being turned  | 0.4 - 0.8 V  |

A

EC

C

D

E

F

G

H

I

J

K

L

M

N

O

P

# ECM

< ECU DIAGNOSIS INFORMATION >

[VK56VD FOR MEXICO]

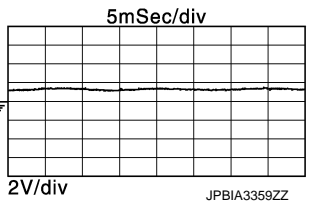
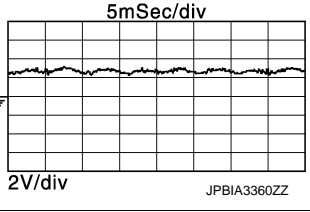
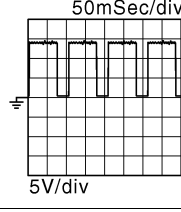
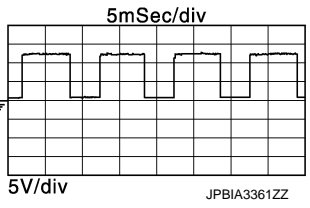
| Terminal No.<br>(Wire color)                 |            | Description   | Input/<br>Output | Condition   | Value<br>(Approx.)  |
|--|------------|---|------------------|---|---|
| +  | -          | Signal name   |                  |   |   |
| 40<br>(B)                                    | —          | Sensor ground<br>(Fuel rail pressure sensor/Engine oil pressure sensor/Engine coolant temperature sensor/Engine oil temperature sensor) | —                | —   | —   |
| 41<br>(G)                                    | 40<br>(B)  | Engine oil pressure sensor  | Input            | [Engine is running]<br>• Warm-up condition<br>• Idle speed  | 1.3 V★<br>         |
|  |            |   |                  | [Engine is running]<br>• Warm-up condition<br>• Engine speed: 2,000 rpm   | 2.7 V★<br>         |
| 42<br>(L) <sup>*1</sup><br>(B) <sup>*2</sup> | 40<br>(B)  | Engine oil temperature sensor   | Input            | [Engine is running]   | 0 - 4.8 V<br>Output voltage varies with engine oil temperature.                                       |
| 45<br>(V)                                    | —          | Sensor ground<br>(Power steering pressure sensor/ Low fuel pressure sensor)   | —                | —   | —   |
| 46<br>(LG)                                   | 175<br>(B) | Fuel injector driver power supply   | Input            | [Ignition switch: ON]   | BATTERY VOLTAGE<br>(11 - 14 V)  |
| 47<br>(BR)                                   | 175<br>(B) | Heated oxygen sensor 2 heater (bank 1)  | Input            | [Engine is running]<br>• Engine speed: Below 3,600 rpm after the following conditions are met<br>- Engine: after warming up<br>- Keeping the engine speed between 3,500 and 4,000 rpm for 1 minute and at idle for 1 minute under no load | 10 V★<br>        |
|  |            |   |                  | [Ignition switch: ON]<br>• Engine: Stopped<br>[Engine is running]<br>• Engine speed: Above 3,600 rpm  | BATTERY VOLTAGE<br>(11 - 14 V)  |
| 48<br>(Y)                                    | 175<br>(B) | A/F sensor 1 heater (bank 1)  | Input            | [Engine is running]<br>• Warm-up condition<br>• Idle speed<br>(More than 140 seconds after starting engine)   | 2.9 - 8.8 V★<br> |

# ECM

< ECU DIAGNOSIS INFORMATION >

[VK56VD FOR MEXICO]

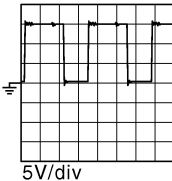
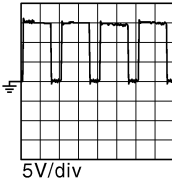
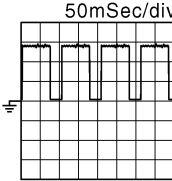
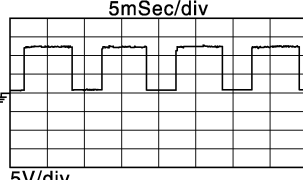
| Terminal No.<br>(Wire color) |            | Description  |                  | Condition   | Value<br>(Approx.)  |
|------------------------------|------------|--|------------------|---|---|
| +                            | -          | Signal name  | Input/<br>Output |   |   |
| 49<br>(GR)                   | 175<br>(B) | Intake valve timing control solenoid valve (bank 2)  | Output           | [Engine is running]<br>• Warm-up condition<br>• Idle speed  | BATTERY VOLTAGE<br>(11 - 14 V)  |
|                              |            |  |                  | [Engine is running]<br>• Warm-up condition<br>• Engine speed: 2,000rpm  | 7 - 12 V★<br>      |
| 50<br>(V)                    | 175<br>(B) | Exhaust valve timing control solenoid valve (bank 2) | Output           | [Engine is running]<br>• Warm-up condition<br>• Idle speed  | BATTERY VOLTAGE<br>(11 - 14 V)  |
|                              |            |  |                  | [Engine is running]<br>• Warm-up condition<br>• Around 2,500 rpm while the engine speed is rising   | 7 - 12 V★<br>      |
| 51<br>(W)                    | 175<br>(B) | Fuel injector driver power supply                    | Output           | [Engine is running]<br>• Warm-up condition<br>• Idle speed  | BATTERY VOLTAGE<br>(11 - 14 V)  |
| 52<br>(G)                    | 175<br>(B) | Heated oxygen sensor 2 heater (bank 2)               | Output           | [Engine is running]<br>• Engine speed: Below 3,600 rpm after the following conditions are met<br>- Engine: after warming up<br>- Keeping the engine speed between 3,500 and 4,000 rpm for 1 minute and at idle for 1 minute under no load | 10 V★<br>        |
|                              |            |  |                  | [Ignition switch: ON]<br>• Engine: Stopped<br>[Engine is running]<br>• Engine speed: Above 3,600 rpm  | BATTERY VOLTAGE<br>(11 - 14 V)  |
| 53<br>(P)                    | 175<br>(B) | A/F sensor 1 heater (bank 2)                         | Output           | [Engine is running]<br>• Warm-up condition<br>• Idle speed<br>(More than 140 seconds after starting engine)   | 2.9 - 8.8 V★<br> |

A  
EC  
C  
D  
E  
F  
G  
H  
I  
J  
K  
L  
M  
N  
O  
P

# ECM

< ECU DIAGNOSIS INFORMATION >

[VK56VD FOR MEXICO]

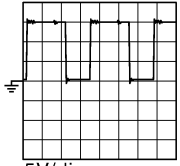
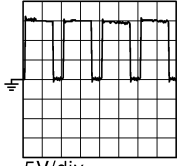
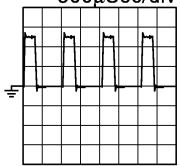
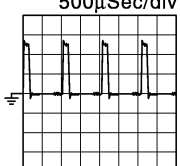
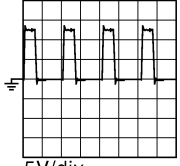
| Terminal No.<br>(Wire color) |            | Description  |                  | Condition   | Value<br>(Approx.)  |
|------------------------------|------------|--|------------------|---|---|
| +                            | -          | Signal name  | Input/<br>Output |   |   |
| 54<br>(SB)                   | 175<br>(B) | Intake valve timing control solenoid valve (bank 1)  | Output           | [Engine is running]<br>• Warm-up condition<br>• Idle speed  | BATTERY VOLTAGE<br>(11 - 14 V)  |
|                              |            |  |                  | [Engine is running]<br>• Warm-up condition<br>• Engine speed: 2,000rpm  | 7 - 12 V★<br><br>5V/div JMBIA0038GB                  |
| 55<br>(R)                    | 175<br>(B) | Exhaust valve timing control solenoid valve (bank 1) | Output           | [Engine is running]<br>• Warm-up condition<br>• Idle speed  | BATTERY VOLTAGE<br>(11 - 14 V)  |
|                              |            |  |                  | [Engine is running]<br>• Warm-up condition<br>• Around 2,500 rpm while the engine speed is rising                                       | 7 - 12 V★<br><br>5V/div JMBIA0034GB                  |
| 57<br>(L)                    | 175<br>(B) | Throttle control motor (bank 1) (Open)               | Output           | [Ignition switch: ON]<br>• Engine: Stopped<br>• Selector lever: D<br>• Accelerator pedal: Fully depressed                               | 0 - 14 V★<br>500µSec/div<br><br>5V/div JMBIA0031GB |
|                              |            |  |                  | [Ignition switch: ON]<br>• Engine: Stopped<br>• Selector lever: D position<br>• Accelerator pedal: Fully released                       | 0 - 14 V★<br>500µSec/div<br><br>5V/div JMBIA0032GB |
| 58<br>(G)                    | 175<br>(B) | Throttle control motor (bank 2) (Close)              | Output           | [Ignition switch: ON]<br>• Engine: Stopped<br>• Selector lever: D position<br>• Accelerator pedal: In the middle of releasing operation | 0 - 14 V★<br>500µSec/div<br><br>5V/div JMBIA0031GB |
| 60<br>(B/W)                  | —          | Shield   | —                | —   | —   |

# ECM

< ECU DIAGNOSIS INFORMATION >

[VK56VD FOR MEXICO]

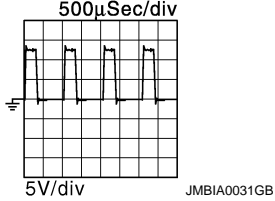
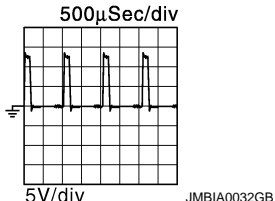
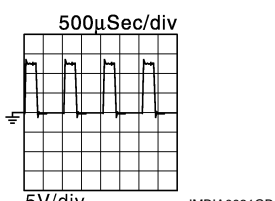
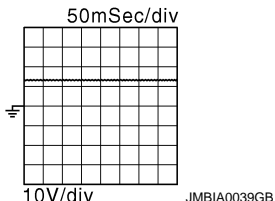
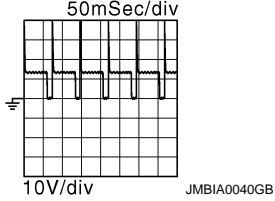
| Terminal No.<br>(Wire color) |            | Description  |                  | Condition   | Value<br>(Approx.)   |
|------------------------------|------------|--|------------------|---|--|
| +                            | -          | Signal name  | Input/<br>Output |   |  |
| 62<br>(R)                    | 175<br>(B) | Throttle control motor (bank 2)<br>(Open)  | Output           | [Ignition switch: ON]<br>• Engine: Stopped<br>• Selector lever: D<br>• Accelerator pedal: Fully depressed                               | 0 - 14 V★<br>                         |
|                              |            |  |                  | [Ignition switch: ON]<br>• Engine: Stopped<br>• Selector lever: D position<br>• Accelerator pedal: Fully released                       | 0 - 14 V★<br>                         |
| 63<br>(P)                    | 175<br>(B) | Throttle control motor (bank 1)<br>(Close)   | Output           | [Ignition switch: ON]<br>• Engine: Stopped<br>• Selector lever: D position<br>• Accelerator pedal: In the middle of releasing operation | 0 - 14 V★<br>                        |
| 64<br>(GR)                   | 175<br>(B) | EVAP canister purge volume control solenoid valve  | Output           | [Engine is running]<br>• Idle speed<br>• Accelerator pedal: Not depressed even slightly, after engine starting                          | BATTERY VOLTAGE<br>(11 - 14 V)★<br> |
|                              |            |  |                  | [Engine is running]<br>• Engine speed: About 2,000 rpm<br>(More than 100 seconds after starting engine)                                 | BATTERY VOLTAGE<br>(11 - 14 V)★<br> |
| 67<br>(R)                    | 175<br>(B) | Manifold absolute pressure sensor  | Input            | [Engine is running]<br>• Warm-up condition<br>• Idle speed  | 1.2 V  |
|                              |            |  |                  | [Engine is running]<br>• Warm-up condition<br>• Engine speed: 2,000 rpm   | 1.5 V  |
| 68<br>(L)                    | —          | Sensor ground<br>[Camshaft position sensor (bank 1)/Exhaust valve timing control position sensor (bank 1)] | —                | —   | —  |

A

EC

C

D

E

F

G

H

I

J

K

L

M

N

O

P

# ECM

## < ECU DIAGNOSIS INFORMATION >

**[VK56VD FOR MEXICO]**

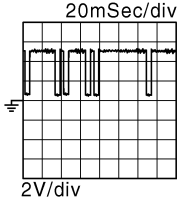
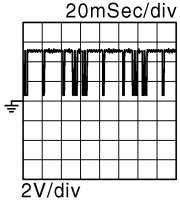
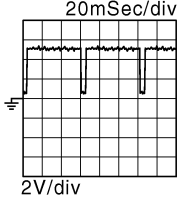
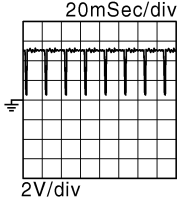
| Terminal No.<br>(Wire color) |            | Description  | Input/<br>Output | Condition  | Value<br>(Approx.)  |
|------------------------------|------------|--|------------------|--|---|
| +                            | -          | Signal name  |                  |  |   |
| 69<br>(O/L)                  | —          | Sensor ground<br>[Throttle position sensor (bank 2)]       | —                | —  | —   |
| 70<br>(G)                    | —          | Sensor ground<br>(Manifold absolute pressure sensor)       | —                | —  | —   |
| 71<br>(O)                    | 97<br>(G)  | Throttle position sensor 1<br>(bank 2)                     | Input            | [Ignition switch: ON]<br>• Engine: Stopped<br>• Selector lever: D position<br>• Accelerator pedal: Fully released              | More than 0.36 V  |
|                              |            |  |                  | [Ignition switch: ON]<br>• Engine: Stopped<br>• Selector lever: D position<br>• Accelerator pedal: Fully depressed             | Less than 4.75 V  |
| 73<br>(B)                    | 99<br>(R)  | Camshaft position sensor<br>(bank 2)                       | Input            | [Engine is running]<br>• Warm-up condition<br>• Idle speed<br><b>NOTE:</b><br>The pulse cycle changes depending on rpm at idle | 3.0 - 5.0 V★<br>   |
|                              |            |  |                  | [Engine is running]<br>• Engine speed: 2,000 rpm   | 3.0 - 5.0 V★<br> |
| 74<br>(L/W)                  | 175<br>(B) | A/F sensor 1 (bank 2)                                      | Input            | [Ignition switch: ON]  | 2.5 V   |
| 75<br>(R)                    | 68<br>(L)  | Exhaust valve timing control position sensor (bank 1)      | Input            | [Engine is running]<br>• Warm-up condition<br>• Idle speed<br><b>NOTE:</b><br>The pulse cycle changes depending on rpm at idle | 4.0 - 5.0 V★<br> |
|                              |            |  |                  | [Engine is running]<br>• Warm-up condition<br>• Engine speed: 2,000 rpm  | 4.0 - 5.0 V★<br> |
| 76<br>(B)                    | 86<br>(L)  | Sensor power supply<br>(Crankshaft position sensor)        | —                | [Ignition switch: ON]  | 5 V   |
| 77<br>(B)                    | 68<br>(L)  | Sensor power supply<br>[Camshaft position sensor (bank 1)] | —                | [Ignition switch: ON]  | 5 V   |

# ECM

< ECU DIAGNOSIS INFORMATION >

[VK56VD FOR MEXICO]

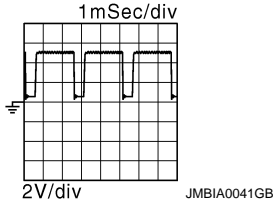
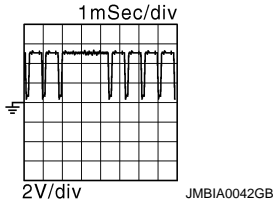
| Terminal No.<br>(Wire color) |             | Description   | Input/<br>Output | Condition  | Value<br>(Approx.)  |
|------------------------------|-------------|---|------------------|--|---|
| +                            | -           | Signal name   |                  |  |   |
| 78<br>(L/R)                  | 175<br>(B)  | A/F sensor 1 (bank 2)   | Input            | [Engine is running]<br>• Warm-up condition<br>• Engine speed: 2,000 rpm  | 2.2 - 2.8V<br>Output voltage varies with air fuel ratio.  |
| 79<br>(B)                    | 97<br>(G)   | Throttle position sensor 2<br>(bank 1)                        | Input            | [Ignition switch: ON]<br>• Engine: Stopped<br>• Selector lever: D position<br>• Accelerator pedal: Fully released  | Less than 4.75 V  |
|                              |             |   |                  | [Ignition switch: ON]<br>• Engine: Stopped<br>• Selector lever: D position<br>• Accelerator pedal: Fully depressed   | More than 0.36 V  |
| 80<br>(L)                    | 175<br>(B)  | Sensor power supply<br>[A/F sensor 1 (bank 2)]                | —                | [Ignition switch: ON]  | 3.0 V   |
| 81<br>(W)                    | 97<br>(G)   | Sensor power supply<br>[Throttle position sensor (bank 1)]    | —                | [Ignition switch: ON]  | 5 V   |
| 82<br>(W)                    | 69<br>(O/L) | Sensor power supply<br>[Throttle position sensor (bank 2)]    | —                | [Ignition switch: ON]  | 5 V   |
| 83<br>(L)                    | 175<br>(B)  | Sensor power supply<br>[Camshaft position sensor<br>(bank 2)] | —                | [Ignition switch: ON]  | 5 V   |
| 85<br>(W)                    | 175<br>(B)  | Sensor power supply<br>(Manifold absolute pressure<br>sensor) | —                | [Ignition switch: ON]  | 5 V   |
| 86<br>(L)                    | 98<br>(R)   | Crankshaft position sensor                                    | Input            | [Engine is running]<br>• Warm-up condition<br>• Idle speed<br><b>NOTE:</b><br>The pulse cycle changes depending<br>on rpm at idle  | 4.0 - 5.0 V★<br> |
|                              |             |   |                  | [Engine is running]<br>• Engine speed: 2,000 rpm   | 4.0 - 5.0 V★<br> |
| 87<br>(BR)                   | 100<br>(P)  | Heated oxygen sensor 2 (bank 2)                               | Input            | [Engine is running]<br>• Revving engine from idle to 3,000<br>rpm quickly after the following condi-<br>tions are met<br>- Engine: after warming up<br>- Keeping the engine speed between<br>3,500 and 4,000 rpm for 1 minute<br>and at idle for 1 minute under no<br>load | 0 - 1.0 V   |
| 88<br>(L/W)                  | 175<br>(B)  | A/F sensor 1 (bank 1)   | Input            | [Engine is running]<br>• Warm-up condition<br>• Engine speed: 2,000 rpm  | 2.2 - 2.8 V<br>Output voltage varies with air fuel<br>ratio.  |

A

EC

C

D

E

F

G

H

I

J

K

L

M

N

O

P

# ECM

## < ECU DIAGNOSIS INFORMATION >

**[VK56VD FOR MEXICO]**

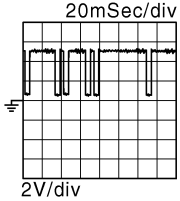
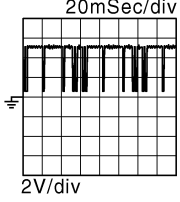
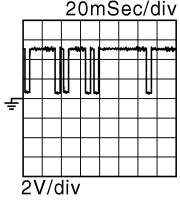
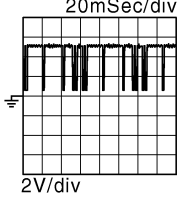
| Terminal No.<br>(Wire color) |             | Description  | Input/<br>Output | Condition   | Value<br>(Approx.)   |
|------------------------------|-------------|--|------------------|---|--|
| +                            | -           | Signal name  |                  |   |  |
| 89<br>(W/L)                  | 69<br>(O/L) | Throttle position sensor 2<br>(bank 2)                   | Input            | [Ignition switch: ON]<br>• Engine: Stopped<br>• Selector lever: D position<br>• Accelerator pedal: Fully released                 | Less than 4.75 V   |
|                              |             |  |                  | [Ignition switch: ON]<br>• Engine: Stopped<br>• Selector lever: D position<br>• Accelerator pedal: Fully depressed                | More than 0.36 V   |
| 90<br>(L/R)                  | 175<br>(B)  | Sensor power supply<br>[A/F sensor 1 (bank 1)]           | —                | [Ignition switch: ON]   | 3.0 V  |
| 91<br>(R)                    | 175<br>(B)  | Throttle position sensor 1<br>(bank 1)                   | Input            | [Ignition switch: ON]<br>• Engine: Stopped<br>• Selector lever: D position<br>• Accelerator pedal: Fully released                 | More than 0.36 V   |
|                              |             |  |                  | [Ignition switch: ON]<br>• Engine: Stopped<br>• Selector lever: D position<br>• Accelerator pedal: Fully depressed                | Less than 4.75 V   |
| 93<br>(B)                    | 99<br>(R)   | Exhaust valve timing control<br>position sensor (bank 2) | Input            | [Engine is running]<br>• Warm-up condition<br>• Idle speed<br><b>NOTE:</b><br>The pulse cycle changes depending<br>on rpm at idle | 3.0 - 5.0 V★<br><br>20mSec/div<br>2V/div<br>JMBIA0045GB  |
|                              |             |  |                  | [Engine is running]<br>• Engine speed: 2,000 rpm  | 3.0 - 5.0 V★<br><br>20mSec/div<br>2V/div<br>JMBIA0046GB |
| 94<br>(L)                    | 175<br>(B)  | A/F sensor 1 (bank 1)                                    | Input            | [Ignition switch: ON]   | 2.0 V  |
| 95<br>(R)                    | 68<br>(L)   | Camshaft position sensor<br>(bank 1)                     | Input            | [Engine is running]<br>• Warm-up condition<br>• Idle speed<br><b>NOTE:</b><br>The pulse cycle changes depending<br>on rpm at idle | 3.0 - 5.0 V★<br><br>20mSec/div<br>2V/div<br>JMBIA0045GB |
|                              |             |  |                  | [Engine is running]<br>• Engine speed: 2,000 rpm  | 3.0 - 5.0 V★<br><br>20mSec/div<br>2V/div<br>JMBIA0046GB |



# ECM

< ECU DIAGNOSIS INFORMATION >

[VK56VD FOR MEXICO]

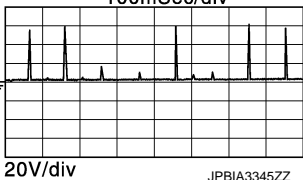
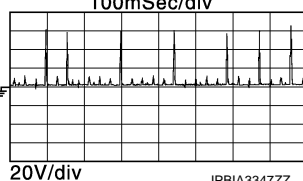
| Terminal No.<br>(Wire color) |            | Description   |                  | Condition  | Value<br>(Approx.)   |
|------------------------------|------------|---|------------------|--|--|
| +                            | -          | Signal name   | Input/<br>Output |  |  |
| 96<br>(Y)                    | 100<br>(P) | Heated oxygen sensor 2 (bank 1)   | Input            | [Engine is running] <ul style="list-style-type: none"> <li>• Revving engine from idle to 3,000 rpm quickly after the following conditions are met</li> <li>- Engine: after warming up</li> <li>- Keeping the engine speed between 3,500 and 4,000 rpm for 1 minute and at idle for 1 minute under no load</li> </ul> | 0 - 1.0 V  |
| 97<br>(G)                    | —          | Sensor ground [Throttle position sensor (bank 1)]   | —                | —  | —  |
| 98<br>(R)                    | —          | Sensor ground (Crankshaft position sensor)  | —                | —  | —  |
| 99<br>(R)                    | —          | Sensor ground [Camshaft position sensor (bank 2)/Exhaust valve timing control position sensor (bank 2)] | —                | —  | —  |
| 100<br>(P)                   | —          | Sensor ground (Heated oxygen sensor 2)  | —                | —  | —  |
| 101<br>(Y)<br>102<br>(L)     | 175<br>(B) | Fuel injector No. 1 (HI)<br>Fuel injector No. 6 (HI)  | Input            | [Engine is running] <ul style="list-style-type: none"> <li>• Warm-up condition</li> <li>• Idle speed</li> </ul> <b>NOTE:</b><br>The pulse cycle changes depending on rpm at idle   | BATTERY VOLTAGE<br>(11 - 14 V)★<br> |
|                              |            |   |                  | [Engine is running] <ul style="list-style-type: none"> <li>• Warm-up condition</li> <li>• Engine speed: 2,000 rpm</li> </ul>   | BATTERY VOLTAGE<br>(11 - 14 V)★<br> |

A  
EC  
C  
D  
E  
F  
G  
H  
I  
J  
K  
L  
M  
N  
O  
P

# ECM

## < ECU DIAGNOSIS INFORMATION >

**[VK56VD FOR MEXICO]**

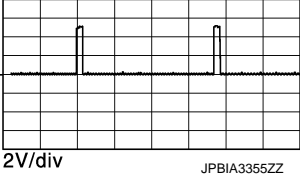
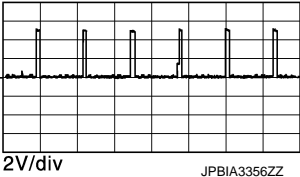
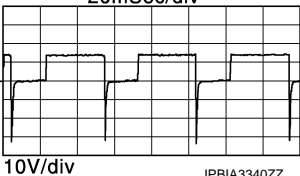
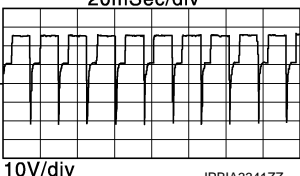
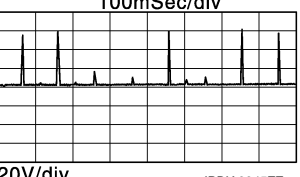
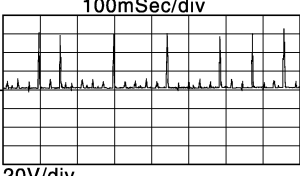
| Terminal No.<br>(Wire color) |            | Description  |                  | Condition  | Value<br>(Approx.)   |
|------------------------------|------------|--|------------------|--|--|
| +                            | -          | Signal name  | Input/<br>Output |  |  |
| 103<br>(B/W)<br>104<br>(BR)  | 175<br>(B) | Fuel injector No. 7 (LO)<br>Fuel injector No. 4 (LO) | Output           | [Engine is running]<br>• Warm-up condition<br>• Idle speed<br><b>NOTE:</b><br>The pulse cycle changes depending on rpm at idle | BATTERY VOLTAGE<br>(11 - 14 V)★<br>50mSec/div<br><br>2V/div JPBIA3355ZZ     |
|                              |            |  |                  | [Engine is running]<br>• Warm-up condition<br>• Engine speed: 2,000 rpm  | BATTERY VOLTAGE<br>(11 - 14 V)★<br>50mSec/div<br><br>2V/div JPBIA3356ZZ     |
| 105<br>(W)                   | 175<br>(B) | High pressure fuel pump (HI)                         | Input            | [Engine is running]<br>• Warm-up condition<br>• Idle speed<br><b>NOTE:</b><br>The pulse cycle changes depending on rpm at idle | BATTERY VOLTAGE<br>(11 - 14 V)★<br>20mSec/div<br><br>10V/div JPBIA3340ZZ   |
|                              |            |  |                  | [Engine is running]<br>• Warm-up condition<br>• Engine speed: 2,000 rpm  | BATTERY VOLTAGE<br>(11 - 14 V)★<br>20mSec/div<br><br>10V/div JPBIA3341ZZ  |
| 106<br>(L)<br>107<br>(Y)     | 175<br>(B) | Fuel injector No. 7 (HI)<br>Fuel injector No. 4 (HI) | Output           | [Engine is running]<br>• Warm-up condition<br>• Idle speed<br><b>NOTE:</b><br>The pulse cycle changes depending on rpm at idle | BATTERY VOLTAGE<br>(11 - 14 V)★<br>100mSec/div<br><br>20V/div JPBIA3345ZZ |
|                              |            |  |                  | [Engine is running]<br>• Warm-up condition<br>• Engine speed: 2,000 rpm  | BATTERY VOLTAGE<br>(11 - 14 V)★<br>100mSec/div<br><br>20V/div JPBIA3347ZZ |

# ECM

< ECU DIAGNOSIS INFORMATION >

[VK56VD FOR MEXICO]

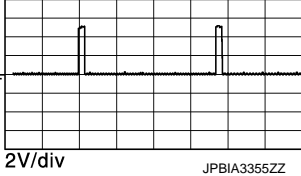
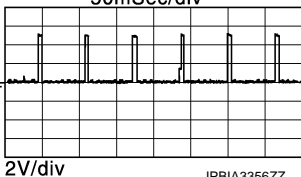
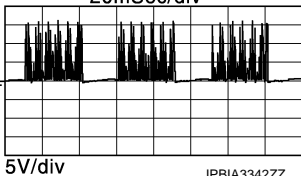
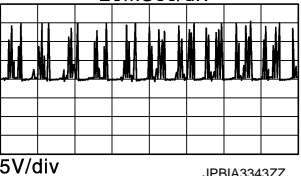
| Terminal No.<br>(Wire color) |            | Description  |                  | Condition  | Value<br>(Approx.)   |
|------------------------------|------------|--|------------------|--|--|
| +                            | -          | Signal name  | Input/<br>Output |  |  |
| 108<br>(BR)<br>109<br>(B/W)  | 175<br>(B) | Fuel injector No. 1 (LO)<br>Fuel injector No. 6 (LO)         | Output           | [Engine is running]<br>• Warm-up condition<br>• Idle speed<br><b>NOTE:</b><br>The pulse cycle changes depending on rpm at idle | BATTERY VOLTAGE<br>(11 - 14 V)★<br>50mSec/div<br> 2V/div<br>JPBIA3355ZZ   |
|                              |            |  |                  | [Engine is running]<br>• Warm-up condition<br>• Engine speed: 2,000 rpm  | BATTERY VOLTAGE<br>(11 - 14 V)★<br>50mSec/div<br> 2V/div<br>JPBIA3356ZZ   |
| 110<br>(B)                   | 175<br>(B) | High pressure fuel pump (LO)                                 | Input            | [Engine is running]<br>• Warm-up condition<br>• Idle speed<br><b>NOTE:</b><br>The pulse cycle changes depending on rpm at idle | BATTERY VOLTAGE<br>(11 - 14 V)★<br>20mSec/div<br> 5V/div<br>JPBIA3342ZZ  |
|                              |            |  |                  | [Engine is running]<br>• Warm-up condition<br>• Engine speed: 2,000 rpm  | BATTERY VOLTAGE<br>(11 - 14 V)★<br>20mSec/div<br> 5V/div<br>JPBIA3343ZZ |
| 111<br>(W)                   | 175<br>(B) | Fuel injector driver power supply                            | Input            | [Ignition switch: ON]  | BATTERY VOLTAGE<br>(11 - 14 V)   |
| 112<br>(W)                   | 175<br>(B) | Fuel injector driver power supply                            | Input            | [Ignition switch: ON]  | BATTERY VOLTAGE<br>(11 - 14 V)   |
| 114<br>(B)                   | —          | ECM ground<br>(Fuel injector)                                | —                | —  | —  |
| 115<br>(B)                   | —          | ECM ground<br>(Fuel injector)                                | —                | —  | —  |
| 120<br>(G)                   | 175<br>(B) | EVAP canister vent control valve                             | Output           | [Ignition switch: ON]  | BATTERY VOLTAGE<br>(11 - 14 V)   |
| 122<br>(V)                   | 175<br>(B) | VVEL actuator motor relay abort signal (VVEL control module) | Input            | [Ignition switch: ON]  | 0 V  |

A

EC

C

D

E

F

G

H

I

J

K

L

M

N

O

P

# ECM

< ECU DIAGNOSIS INFORMATION >

[VK56VD FOR MEXICO]

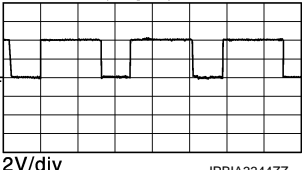
| Terminal No.<br>(Wire color)                   |  | Description   |                  | Condition  | Value<br>(Approx.)  |
|--|--|---|------------------|--|---|
| +  | -  | Signal name   | Input/<br>Output |  |   |
| 123<br>(BG)                                    | 175<br>(B)                                     | Throttle control motor relay                              | Output           | [Ignition switch: ON → OFF]  | 0 - 1.0 V<br>↓<br>BATTERY VOLTAGE<br>(11 - 14 V)<br>↓<br>0 V                                      |
|  |  |   |                  | [Ignition switch: ON]  | 0 - 1.0 V   |
| 125<br>(P)                                     | 175<br>(B)                                     | Fuel pump control module<br>(FPCM)                        | Output           | [When cranking engine]   | 0 - 0.5 V   |
|  |  |   |                  | [Engine is running]<br>• Warm-up condition   | 0 - 4.0 V★<br> |
| 126<br>(Y)                                     | 129<br>(BR) <sup>*1</sup><br>(B) <sup>*2</sup> | Accelerator pedal position<br>sensor 2                    | Input            | [Ignition switch: ON]<br>• Engine: Stopped<br>• Accelerator pedal: Fully released  | 0.22 - 0.5 V  |
|  |  |   |                  | [Ignition switch: ON]<br>• Engine: Stopped<br>• Accelerator pedal: Fully depressed | 2.1 - 2.5 V   |
| 128<br>(SB)                                    | 130<br>(Y)                                     | ASC D steering switch                                     | Input            | [Ignition switch: ON]<br>• ASC D steering switch: OFF                              | 4 V   |
|  |  |   |                  | [Ignition switch: ON]<br>• MAIN switch: Pressed                                    | 0 V   |
|  |  |   |                  | [Ignition switch: ON]<br>• CANCEL switch: Pressed                                  | 1 V   |
|  |  |   |                  | [Ignition switch: ON]<br>• RESUME/ACCELERATE switch:<br>Pressed                    | 3 V   |
|  |  |   |                  | [Ignition switch: ON]<br>• SET/COAST switch: Pressed                               | 2 V   |
| 128<br>(SB)                                    | 130<br>(Y)                                     | ICC steering switch                                       | Input            | [Ignition switch: ON]<br>• ICC steering switch: OFF                                | 4.2 V   |
|  |  |   |                  | [Ignition switch: ON]<br>• MAIN switch: Pressed                                    | 0 V   |
|  |  |   |                  | [Ignition switch: ON]<br>• CANCEL switch: Pressed                                  | 1.9 V   |
|  |  |   |                  | [Ignition switch: ON]<br>• RESUME/ACCELERATE switch:<br>Pressed                    | 3.7 V   |
|  |  |   |                  | [Ignition switch: ON]<br>• SET/COAST switch: Pressed                               | 3.2 V   |
|  |  |   |                  | [Ignition switch: ON]<br>• DISTANCE switch: Pressed                                | 2.6 V   |
|  |  |   |                  | [Ignition switch: ON]<br>• DYNAMIC DRIVE ASSISTANCE<br>switch: Pressed             | 1.0 V   |
| 129<br>(BR) <sup>*1</sup><br>(B) <sup>*2</sup> | —  | Sensor ground<br>(Accelerator pedal position<br>sensor 2) | —                | —  | —   |

# ECM

< ECU DIAGNOSIS INFORMATION >

[VK56VD FOR MEXICO]

| Terminal No.<br>(Wire color) |  | Description  |                  | Condition  | Value<br>(Approx.)             |
|------------------------------|--|--|------------------|--|--------------------------------|
| +                            | -  | Signal name  | Input/<br>Output |  |                                |
| 130<br>(Y)                   | —  | Sensor ground<br>(ASCD steering switch)  | —                | —  | —                              |
| 131<br>(L)                   | 129<br>(BR)* <sup>1</sup><br>(B)* <sup>2</sup> | Sensor power supply<br>(Accelerator pedal position<br>sensor 2)  | —                | [Ignition switch: ON]  | 5 V                            |
| 133<br>(BG)                  | 150<br>(V)                                     | Sensor power supply<br>[Refrigerant pressure sensor/<br>Battery current sensor/EVAP<br>control system pressure sensor] | —                | [Ignition switch: ON]  | 5 V                            |
| 134<br>(P)                   | 175<br>(B)                                     | Fuel temperature sensor  | Input            | [Engine is running]<br>• Warm-up condition   | 2.8 V                          |
| 136<br>(R)                   | 140<br>(W)                                     | Accelerator pedal position<br>sensor 1   | Input            | [Ignition switch: ON]<br>• Engine: Stopped<br>• Accelerator pedal: Fully released  | 0.45 - 1.0 V                   |
|                              |  |  |                  | [Ignition switch: ON]<br>• Engine: Stopped<br>• Accelerator pedal: Fully depressed                                       | 4.4 - 4.8 V                    |
| 137<br>(G)                   | 140<br>(W)                                     | Sensor power supply<br>(Accelerator pedal position<br>sensor 1)  | —                | [Ignition switch: ON]  | 5 V                            |
| 138<br>(P)                   | 175<br>(B)                                     | Battery current sensor   | Input            | [Engine is running]<br>• Battery: Fully charged* <sup>4</sup><br>• Idle speed  | 2.6 - 3.5 V                    |
| 139<br>(BG)                  | 175<br>(B)                                     | Battery temperature sensor   | Input            | [Engine is running]<br>• Battery temperature: 25°C<br>• Idle speed   | 3.3 V                          |
| 140<br>(W)                   | —  | Sensor ground<br>(Accelerator pedal position<br>sensor 1)  | —                | —  | —                              |
| 141<br>(G)                   | 175<br>(B)                                     | Ignition switch  | Input            | [Ignition switch: OFF]   | 0 V                            |
|                              |  |  |                  | [Ignition switch: ON]  | BATTERY VOLTAGE<br>(11 - 14 V) |
| 142<br>(GR)                  | 175<br>(B)                                     | Fuel pump control module<br>(FPCM) check   | Input            | [When cranking engine]   | 0 V                            |
|                              |  |  |                  | [Engine is running]<br>• Warm-up condition<br>• Idle speed   | 9 V                            |
| 143<br>(P)                   | 175<br>(B)                                     | Fuel tank pressure sensor  | Input            | [Engine is running]<br>• Warm-up condition   | 4 V                            |
| 144<br>(LG)                  | 150<br>(V)                                     | Refrigerant pressure sensor  | Input            | [Engine is running]<br>• Warm-up condition<br>• Both A/C switch and blower fan motor<br>switch: ON (Compressor operates) | 1.0 - 4.0 V                    |
| 146<br>(L)                   | —  | CAN communication line   | —                | —  | —                              |
| 147<br>(BR)                  | 175<br>(B)                                     | ASCD/ICC brake switch  | Input            | [Ignition switch: ON]<br>• Brake pedal: Slightly depressed   | 0 V                            |
|                              |  |  |                  | [Ignition switch: ON]<br>• Brake pedal: Fully released   | BATTERY VOLTAGE<br>(11 - 14 V) |

A

EC

C

D

E

F

G

H

I

J

K

L

M

N

O

P

# ECM

< ECU DIAGNOSIS INFORMATION >

[VK56VD FOR MEXICO]

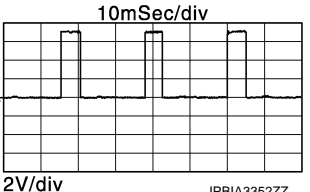
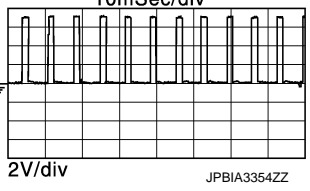
| Terminal No.<br>(Wire color) |            | Description  | Input/<br>Output | Condition   | Value<br>(Approx.)  |
|------------------------------|------------|--|------------------|---|---|
| +                            | -          | Signal name  |                  |   |   |
| 150<br>(V)                   | —          | Sensor ground<br>[Refrigerant pressure sensor/<br>Battery current sensor/EVAP<br>control system pressure sensor] | —                | —   | —   |
| 151<br>(P)                   | —          | CAN communication line   | —                | —   | —   |
| 156<br>(W)                   | 175<br>(B) | Power supply for ECM (Back-up)   | Input            | [Ignition switch: OFF]  | BATTERY VOLTAGE<br>(11 - 14 V)  |
| 158<br>(P)                   | 175<br>(B) | Stop lamp switch   | Input            | [Ignition switch: OFF]<br>• Brake pedal: Fully released   | 0 V   |
|                              |            |  |                  | [Ignition switch: OFF]<br>• Brake pedal: Slightly depressed   | BATTERY VOLTAGE<br>(11 - 14 V)  |
| 161<br>(Y)                   | —          | ENG communication line   | —                | —   | —   |
| 163<br>(W)                   | 175<br>(B) | ECM relay (Self shut-off)  | Output           | [Engine is running]<br>[Ignition switch: OFF]<br>• A few seconds after turning ignition<br>switch OFF                             | 0 - 1.5 V   |
|                              |            |  |                  | [Ignition switch: OFF]<br>• More than a few seconds after turning<br>ignition switch OFF  | BATTERY VOLTAGE<br>(11 - 14 V)  |
| 166<br>(BG)                  | —          | ENG communication line   | —                | —   | —   |
| 169<br>(V)                   | 175<br>(B) | Engine speed signal output   | Input            | [Engine is running]<br>• Warm-up condition<br>• Idle speed<br><b>NOTE:</b><br>The pulse cycle changes depending<br>on rpm at idle | 0 - 7.0 V★<br> |
|                              |            |  |                  | [Engine is running]<br>• Warm-up condition<br>• Engine speed: 2,000 rpm   | 0 - 7.0 V★<br> |
| 171<br>(SB)                  | 175<br>(B) | Power supply for ECM   | Input            | [Ignition switch: ON]   | BATTERY VOLTAGE<br>(11 - 14 V)  |
| 172<br>(SB)                  | 175<br>(B) | Power supply for ECM   | Input            | [Ignition switch: ON]   | BATTERY VOLTAGE<br>(11 - 14 V)  |
| 173<br>(R)                   | 175<br>(B) | Throttle control motor power<br>supply   | Input            | [Ignition switch: ON]   | BATTERY VOLTAGE<br>(11 - 14 V)  |
| 174<br>(B)                   | —          | ECM ground   | —                | —   | —   |
| 175<br>(B)                   | —          | ECM ground   | —                | —   | —   |

★: Average voltage for pulse signal (Actual pulse signal can be confirmed by oscilloscope.)

\*1: With ICC.

\*2: Without ICC.

\*3: This may vary depending on internal resistance of the tester.

\*4: Before measuring the terminal voltage, confirm that the battery is fully charged. Refer to [PG-135, "How to Handle Battery"](#).

Fail-safe

INFOID:000000007758179

NON DTC RELATED ITEM

| Detected items                     | Engine operating condition in fail-safe mode                       | Remarks   | Reference page                                 |
|------------------------------------|--|---|--|
| Malfunction indicator lamp circuit | Engine speed will not rise more than 2,500 rpm due to the fuel cut | When there is an open circuit on MIL circuit, the ECM cannot warn the driver by illuminating MIL when there is malfunction on engine control system.<br>Therefore, when electrical controlled throttle and part of ECM related diagnoses are continuously detected as NG for 5 trips, ECM warns the driver that engine control system malfunctions and MIL circuit is open by means of operating the fail-safe function.<br>The fail-safe function also operates when above diagnoses except MIL circuit are detected and demands the driver to repair the malfunction. | <a href="#">EC-1992, "Diagnosis Procedure"</a> |

DTC RELATED ITEM

| DTC No.   | Detected items                            | Engine operating condition in fail-safe mode   |  |
|---|---|--|--|
| U0113<br>U1003<br>U1024   | Can communication circuit                 | VVEL actuator motor relay is turned off, and VVEL value is become at a minimum angle.<br>Engine speed will not rise more than 3,500 rpm due to the fuel cut. |  |
| P0011<br>P0021  | Intake valve timing control               | The signal is not energized to the intake valve timing control solenoid valve and the valve control does not function.                                       |  |
| P0014<br>P0024  | Exhaust valve timing control              | The signal is not energized to the exhaust valve timing control magnet retarder and the magnet retarder control does not function.                           |  |
| P0087   | FRP control system                        | <ul style="list-style-type: none"> <li>Engine torque is limited.</li> <li>VVEL value is maintained at a fixed angle.</li> </ul>                              |  |
| P0088   |   | Engine speed is limited.   |  |
| P008A   | Low fuel pressure control system          | Engine torque is limited.  |  |
| P0090   | FRP control system                        | <ul style="list-style-type: none"> <li>Engine torque is limited.</li> <li>VVEL value is maintained at a fixed angle.</li> </ul>                              |  |
| P0102<br>P0103<br>P010C<br>P010D  | Mass air flow sensor circuit              | Engine speed will not rise more than 2,400 rpm due to the fuel cut.  |  |
| P0117<br>P0118  | Engine coolant temperature sensor circuit | Engine coolant temperature will be determined by ECM based on the following condition. CONSULT displays the engine coolant temperature decided by ECM.       |  |
|   |   | Condition  | Engine coolant temperature decided (CONSULT display) |
|   |   | Just as ignition switch is turned ON or START  | 40°C (104°F)   |
|   |   | Approx. 4 minutes or more after engine starting  | 80°C (176°F)   |
|   |   | Except as shown above  | 40 - 80°C (104 - 176°F)<br>(Depends on the time)     |
| When the fail-safe system for engine coolant temperature sensor is activated, the cooling fan operates while engine is running. |   |  |  |

# ECM

< ECU DIAGNOSIS INFORMATION >

[VK56VD FOR MEXICO]

| DTC No.  | Detected items                     | Engine operating condition in fail-safe mode  |
|--|------------------------------------|---|
| P0122<br>P0123<br>P0222<br>P0223<br>P0227<br>P0228<br>P1239<br>P2132<br>P2133<br>P2135 | Throttle position sensor           | The ECM controls the electric throttle control actuator in regulating the throttle opening in order for the idle position to be within +10 degrees.<br>The ECM regulates the opening speed of the throttle valve to be slower than the normal condition.<br>Therefore, the acceleration will be poor. |
| P0190  | FRP sensor                         | <ul style="list-style-type: none"> <li>• Engine speed is limited.</li> <li>• High pressure fuel pump is activated at maximum discharge pressure.</li> </ul>   |
| P0197<br>P0198   | Engine oil temperature sensor      | Exhaust valve timing control does not function.   |
| P0201<br>P0202<br>P0203<br>P0204<br>P0205<br>P0206<br>P0207<br>P0208                   | Injector                           | <ul style="list-style-type: none"> <li>• Engine torque is limited.</li> <li>• Fuel injection shut-off of malfunction cylinder.</li> <li>• Mixture ratio feedback control does not function.</li> <li>• Idle engine speed is increased.</li> </ul>   |
| P0500  | Vehicle speed sensor               | The cooling fan operates (Highest) while engine is running.   |
| P0524  | Engine oil pressure                | The signal is not energized to the intake valve timing control solenoid valve and the valve control does not function.<br>Engine speed will not rise more than 2,400 rpm due to the fuel cut.   |
| P0605  | ECM                                | (When ECM calculation function is malfunctioning:)<br>ECM stops the electric throttle control actuator control, throttle valve is maintained at a fixed opening (approx. 5 degrees) by the return spring.<br>ECM deactivates ASCD operation.  |
| P0607  | ECM                                | VVEL actuator motor relay is turned off, and VVEL value is become at a minimum angle.<br>Engine speed will not rise more than 3,500 rpm due to the fuel cut.  |
| P062B  | ECM                                | Type1 <ul style="list-style-type: none"> <li>• Engine torque is limited.</li> <li>• Idle engine speed is increased.</li> <li>• Fuel injector power supply shut-off.</li> <li>• High fuel pressure limitation.</li> </ul>  |
|  |                                    | Type2 <ul style="list-style-type: none"> <li>• Engine torque is limited.</li> <li>• Fuel injection shut-off of malfunction cylinder.</li> <li>• Mixture ratio feedback control does not function.</li> <li>• Idle engine speed is increased.</li> </ul>   |
| P0643  | Sensor power supply                | ECM stops the electric throttle control actuator control, throttle valve is maintained at a fixed opening (approx. 5 degrees) by the return spring.   |
| P1087<br>P1088   | VVEL control function              | VVEL of normal bank is controlled at VVEL angle of abnormal bank.<br>Engine speed will not rise more than 3,500 rpm due to the fuel cut.  |
| P1089<br>P1092   | VVEL control shaft position sensor | VVEL value is maintained at a fixed angle.<br>Engine speed will not rise more than 3,500 rpm due to the fuel cut  |
| P1090<br>P1093   | VVEL actuator motor                | VVEL of normal bank is controlled at VVEL angle of abnormal bank.<br>Engine speed will not rise more than 3,500 rpm due to the fuel cut.  |
|  |                                    | VVEL actuator motor relay is turned off, and VVEL value is become at a minimum angle.<br>Engine speed will not rise more than 3,500 rpm due to the fuel cut.  |
| P1091  | VVEL actuator motor relay          | VVEL actuator motor relay is turned off, and VVEL value is become at a minimum angle.<br>Engine speed will not rise more than 3,500 rpm due to the fuel cut.  |
| P1197  | Out of gas                         | <ul style="list-style-type: none"> <li>• Engine torque is limited.</li> <li>• VVEL value is maintained at a fixed angle.</li> </ul>   |



# ECM

< ECU DIAGNOSIS INFORMATION >

[VK56VD FOR MEXICO]

| DTC No.                                   | Detected items                     | Engine operating condition in fail-safe mode  |                   |
|---|------------------------------------|---|-------------------|
| P1233<br>P2101                            | Electric throttle control function | ECM stops the electric throttle control actuator control, throttle valve is maintained at a fixed opening (approx. 5 degrees) by the return spring.   |                   |
| P1236<br>P2118                            | Throttle control motor             | ECM stops the electric throttle control actuator control, throttle valve is maintained at a fixed opening (approx. 5 degrees) by the return spring.   |                   |
| P1238<br>P2119                            | Electric throttle control actuator | (When electric throttle control actuator does not function properly due to the return spring malfunction:)<br>ECM controls the electric throttle actuator by regulating the throttle opening around the idle position. The engine speed will not rise more than 2,000 rpm.                            |                   |
|   |                                    | (When throttle valve opening angle in fail-safe mode is not in specified range:)<br>ECM controls the electric throttle control actuator because of regulating the throttle opening to 20 degrees or less.   |                   |
|   |                                    | (When ECM detects the throttle valve is stuck open:)<br>While the vehicle is being driven, it slows down gradually by fuel cut. After the vehicle stops, the engine stalls.<br>The engine can restart in the N or P position, and engine speed will not exceed 1,000 rpm or more.                     |                   |
| P2100<br>P2103                            | Throttle control motor relay       | ECM stops the electric throttle control actuator control, throttle valve is maintained at a fixed opening (approx. 5 degrees) by the return spring.   |                   |
| P1606                                     | VVEL control module                | VVEL actuator motor relay is turned off, and VVEL value is become at a minimum angle. Engine speed will not rise more than 3,500 rpm due to the fuel cut.   |                   |
| P1608                                     | VVEL control shaft position sensor | VVEL actuator motor relay is turned off, and VVEL value is become at a minimum angle. Engine speed will not rise more than 3,500 rpm due to the fuel cut.   |                   |
| P1805                                     | Brake switch                       | ECM controls the electric throttle control actuator by regulating the throttle opening to a small range.<br>Therefore, acceleration will be poor.   |                   |
|   |                                    | Vehicle condition   | Driving condition |
|   |                                    | When engine is idling   | Normal            |
|   |                                    | When accelerating   | Poor acceleration |
| P2122<br>P2123<br>P2127<br>P2128<br>P2138 | Accelerator pedal position sensor  | The ECM controls the electric throttle control actuator in regulating the throttle opening in order for the idle position to be within +10 degrees.<br>The ECM regulates the opening speed of the throttle valve to be slower than the normal condition.<br>Therefore, the acceleration will be poor. |                   |
| P2539                                     | Low fuel pressure sensor           | Engine torque is limited.   |                   |

## DTC Inspection Priority Chart

INFOID:000000007758180

If some DTCs are displayed at the same time, perform inspections one by one based on the following priority chart.

| Priority | Detected items (DTC)  |
|----------|---|
| 1        | <ul style="list-style-type: none"> <li>• U0101 CAN communication line</li> <li>• U0113 U1003 CAN communication line</li> <li>• U1001 CAN communication line</li> <li>• U1024 VVEL CAN communication line</li> <li>• P0102 P0103 P010C P010D Mass air flow sensor</li> <li>• P0112 P0113 Intake air temperature sensor</li> <li>• P0117 P0118 P0125 Engine coolant temperature sensor</li> <li>• P0122 P0123 P0222 P0223 P0227 P0228 P1225 P1226 P1234 P1235 P1239 P2132 P2133 P2135 Throttle position sensor</li> <li>• P0197 P0198 Engine oil temperature sensor</li> <li>• P0327 P0328 P0332 P0333 Knock sensor</li> <li>• P0335 Crankshaft position sensor</li> <li>• P0340 P0345 Camshaft position sensor</li> <li>• P0500 Vehicle speed sensor</li> <li>• P0520 EOP sensor</li> <li>• P0605 P0607 P0611 P062B ECM</li> <li>• P0643 Sensor power supply</li> <li>• P0705 P0850 Transmission range switch</li> <li>• P1089 P1092 P1608 VVEL control shaft position sensor</li> <li>• P1197 Out of gas*</li> <li>• P1550 P1551 P1552 P1553 P1554 Battery current sensor</li> <li>• P1556 P1557 Battery temperature sensor</li> <li>• P1606 P1607 VVEL control module</li> <li>• P1610 - P1615 NATS</li> <li>• P1806 Brake booster pressure sensor</li> <li>• P2122 P2123 P2127 P2128 P2138 Accelerator pedal position sensor</li> <li>• P2539 Low fuel pressure sensor</li> </ul> |

| Priority | Detected items (DTC)  |
|----------|---|
| 2        | <ul style="list-style-type: none"> <li>• P0031 P0032 P0051 P0052 Air fuel ratio (A/F) sensor 1 heater</li> <li>• P0037 P0038 P0057 P0058 Heated oxygen sensor 2 heater</li> <li>• P0075 P0081 Intake valve timing control solenoid valve</li> <li>• P0078 P0084 Exhaust valve timing control solenoid valve</li> <li>• P0090 High pressure fuel pump</li> <li>• P0130 P0131 P0132 P0133 P0150 P0151 P0152 P0153 Air fuel ratio (A/F) sensor 1</li> <li>• P0137 P0138 P0139 P0157 P0158 P0159 Heated oxygen sensor 2</li> <li>• P0190 FRP sensor</li> <li>• P0444 EVAP canister purge volume control solenoid valve</li> <li>• P0550 Power steering pressure sensor</li> <li>• P0603 ECM power supply</li> <li>• P0710 P0717 P0720 P0729 P0730 P0731 P0732 P0733 P0734 P0735 P0740 P0744 P0745 P0750 P0775 P0780 P0795 P1730 P1734 P2713 P2722 P2731 P2807 A/T related sensors, solenoid valves and switches</li> <li>• P1078 P1084 Exhaust valve timing control position sensor</li> <li>• P1087 P1088 VVEL system</li> <li>• P1090 P1093 VVEL actuator motor</li> <li>• P1091 VVEL actuator motor relay</li> <li>• P1217 Engine over temperature (OVERHEAT)</li> <li>• P1233 P2101 Electric throttle control function</li> <li>• P1236 P2118 Throttle control motor</li> <li>• P1805 Brake switch</li> <li>• P2100 P2103 Throttle control motor relay</li> </ul> |
| 3        | <ul style="list-style-type: none"> <li>• P0011 P0021 Intake valve timing control</li> <li>• P0014 P0024 Exhaust valve timing control</li> <li>• P0087, P0088 FRP control system</li> <li>• P008A Low fuel pressure control system</li> <li>• P0171 P0172 P0174 P0175 Fuel injection system function</li> <li>• P0201 - P0208 Injector</li> <li>• P0300 - P0308 Misfire</li> <li>• P0420 P0430 Three way catalyst function</li> <li>• P0506 P0507 Idle speed control system</li> <li>• P0524 Engine oil pressure</li> <li>• P100A P100B VVEL system</li> <li>• P1212 TCS communication line</li> <li>• P1238 P2119 Electric throttle control actuator</li> <li>• P1564 ICC steering switch</li> <li>• P1568 ICC command value</li> <li>• P1572 ICC brake switch</li> <li>• P1574 ICC vehicle speed sensor</li> <li>• P1715 Input speed sensor</li> </ul>   |

**NOTE:**

\*: If "P1197" is displayed with other DTC in priority 1, perform trouble diagnosis for "P1197" first.

**DTC Index**

INFOID:000000007758181

×:Applicable —: Not applicable

| DTC*1         |             | Items<br>(CONSULT screen terms)                                     | SRT code | Trip | MIL               | Reference page          |
|---------------|-------------|---|----------|------|-------------------|-------------------------|
| CONSULT GST*2 | ECM*3       |   |          |      |                   |                         |
| U0101         | 0101        | LOST COMM (TCM)   | —        | 1    | ×                 | <a href="#">EC-1711</a> |
| U0113         | 0113        | CAN COMM CIRCUIT  | —        | 1    | ×                 | <a href="#">EC-1712</a> |
| U1001         | 1001*4      | CAN COMM CIRCUIT  | —        | 1    | —                 | <a href="#">EC-1714</a> |
| U1003         | 1003        | CAN COMM CIRCUIT  | —        | 2    | —                 | <a href="#">EC-1712</a> |
| U1024         | 1024        | VVEL CAN COMM CIRCUIT   | —        | 1    | ×                 | <a href="#">EC-1715</a> |
| <b>P0000</b>  | <b>0000</b> | <b>NO DTC IS DETECTED.<br/>FURTHER TESTING<br/>MAY BE REQUIRED.</b> | —        | —    | <b>Blinking*6</b> | —                       |
| P0011         | 0011        | INT/V TIM CONT-B1   | ×        | 2    | ×                 | <a href="#">EC-1717</a> |

## ECM

&lt; ECU DIAGNOSIS INFORMATION &gt;

[VK56VD FOR MEXICO]

| DTC*1            |       | Items<br>(CONSULT screen terms) | SRT code | Trip | MIL | Reference<br>page       |
|------------------|-------|---------------------------------|----------|------|-----|-------------------------|
| CONSULT<br>GST*2 | ECM*3 |                                 |          |      |     |                         |
| P0014            | 0014  | EXH/V TIM CONT-B1               | —        | 2    | ×   | <a href="#">EC-1721</a> |
| P0021            | 0021  | INT/V TIM CONT-B2               | ×        | 2    | ×   | <a href="#">EC-1717</a> |
| P0024            | 0024  | EXH/V TIM CONT-B2               | —        | 2    | ×   | <a href="#">EC-1721</a> |
| P0031            | 0031  | A/F SEN1 HTR (B1)               | —        | 2    | ×   | <a href="#">EC-1725</a> |
| P0032            | 0032  | A/F SEN1 HTR (B1)               | —        | 2    | ×   | <a href="#">EC-1725</a> |
| P0037            | 0037  | HO2S2 HTR (B1)                  | —        | 2    | ×   | <a href="#">EC-1728</a> |
| P0038            | 0038  | HO2S2 HTR (B1)                  | —        | 2    | ×   | <a href="#">EC-1728</a> |
| P0051            | 0051  | A/F SEN1 HTR (B2)               | —        | 2    | ×   | <a href="#">EC-1725</a> |
| P0052            | 0052  | A/F SEN1 HTR (B2)               | —        | 2    | ×   | <a href="#">EC-1725</a> |
| P0057            | 0057  | HO2S2 HTR (B2)                  | —        | 2    | ×   | <a href="#">EC-1728</a> |
| P0058            | 0058  | HO2S2 HTR (B2)                  | —        | 2    | ×   | <a href="#">EC-1728</a> |
| P0075            | 0075  | INT/V TIM V/CIR-B1              | —        | 2    | ×   | <a href="#">EC-1731</a> |
| P0078            | 0078  | EX V/T ACT/CIRC-B1              | —        | 2    | ×   | <a href="#">EC-1734</a> |
| P0081            | 0081  | INT/V TIM V/CIR-B2              | —        | 2    | ×   | <a href="#">EC-1731</a> |
| P0084            | 0084  | EX V/T ACT/CIRC-B2              | —        | 2    | ×   | <a href="#">EC-1734</a> |
| P0087            | 0087  | LOW FUEL PRES                   | —        | 2    | ×   | <a href="#">EC-1739</a> |
| P0088            | 0088  | HIGH FUEL PRES                  | —        | 2    | ×   | <a href="#">EC-1743</a> |
| P008A            | 008A  | LOW FUEL PRES SYS               | —        | 2    | ×   | <a href="#">EC-1737</a> |
| P0090            | 0090  | FUEL PUMP                       | —        | 2    | ×   | <a href="#">EC-1746</a> |
| P0102            | 0102  | MAF SEN/CIRCUIT-B1              | —        | 1    | ×   | <a href="#">EC-1749</a> |
| P0103            | 0103  | MAF SEN/CIRCUIT-B1              | —        | 1    | ×   | <a href="#">EC-1749</a> |
| P010C            | 010C  | MAF SEN/CIRCUIT-B2              | —        | 1    | ×   | <a href="#">EC-1749</a> |
| P010D            | 010D  | MAF SEN/CIRCUIT-B2              | —        | 1    | ×   | <a href="#">EC-1749</a> |
| P0112            | 0112  | IAT SEN/CIRCUIT-B1              | —        | 2    | ×   | <a href="#">EC-1755</a> |
| P0113            | 0113  | IAT SEN/CIRCUIT-B1              | —        | 2    | ×   | <a href="#">EC-1755</a> |
| P0117            | 0117  | ECT SEN/CIRC                    | —        | 1    | ×   | <a href="#">EC-1757</a> |
| P0118            | 0118  | ECT SEN/CIRC                    | —        | 1    | ×   | <a href="#">EC-1757</a> |
| P0122            | 0122  | TP SEN 2/CIRC-B1                | —        | 1    | ×   | <a href="#">EC-1759</a> |
| P0123            | 0123  | TP SEN 2/CIRC-B1                | —        | 1    | ×   | <a href="#">EC-1759</a> |
| P0125            | 0125  | ECT SENSOR                      | —        | 2    | ×   | <a href="#">EC-1762</a> |
| P0130            | 0130  | A/F SENSOR1 (B1)                | ×        | 2    | ×   | <a href="#">EC-1764</a> |
| P0131            | 0131  | A/F SENSOR1 (B1)                | —        | 2    | ×   | <a href="#">EC-1768</a> |
| P0132            | 0132  | A/F SENSOR1 (B1)                | —        | 2    | ×   | <a href="#">EC-1771</a> |
| P0133            | 0133  | A/F SENSOR1 (B1)                | ×        | 2    | ×   | <a href="#">EC-1774</a> |
| P0137            | 0137  | HO2S2 (B1)                      | ×        | 2    | ×   | <a href="#">EC-1779</a> |
| P0138            | 0138  | HO2S2 (B1)                      | ×        | 2    | ×   | <a href="#">EC-1785</a> |
| P0139            | 0139  | HO2S2 (B1)                      | ×        | 2    | ×   | <a href="#">EC-1793</a> |
| P0150            | 0150  | A/F SENSOR1 (B2)                | ×        | 2    | ×   | <a href="#">EC-1764</a> |
| P0151            | 0151  | A/F SENSOR1 (B2)                | —        | 2    | ×   | <a href="#">EC-1768</a> |
| P0152            | 0152  | A/F SENSOR1 (B2)                | —        | 2    | ×   | <a href="#">EC-1771</a> |
| P0153            | 0153  | A/F SENSOR1 (B2)                | ×        | 2    | ×   | <a href="#">EC-1774</a> |
| P0157            | 0157  | HO2S2 (B2)                      | ×        | 2    | ×   | <a href="#">EC-1779</a> |

## ECM

&lt; ECU DIAGNOSIS INFORMATION &gt;

[VK56VD FOR MEXICO]

| DTC*1            |       | Items<br>(CONSULT screen terms) | SRT code | Trip   | MIL | Reference<br>page       |
|------------------|-------|---------------------------------|----------|--------|-----|-------------------------|
| CONSULT<br>GST*2 | ECM*3 |                                 |          |        |     |                         |
| P0158            | 0158  | HO2S2 (B2)                      | ×        | 2      | ×   | <a href="#">EC-1785</a> |
| P0159            | 0159  | HO2S2 (B2)                      | ×        | 2      | ×   | <a href="#">EC-1793</a> |
| P0171            | 0171  | FUEL SYS-LEAN-B1                | —        | 2      | ×   | <a href="#">EC-1799</a> |
| P0172            | 0172  | FUEL SYS-RICH-B1                | —        | 2      | ×   | <a href="#">EC-1803</a> |
| P0174            | 0174  | FUEL SYS-LEAN-B2                | —        | 2      | ×   | <a href="#">EC-1799</a> |
| P0175            | 0175  | FUEL SYS-RICH-B2                | —        | 2      | ×   | <a href="#">EC-1803</a> |
| P0190            | 0190  | FUEL PRES SEN/CIRC              | —        | 1      | ×   | <a href="#">EC-1807</a> |
| P0197            | 0197  | EOT SEN/CIRC                    | —        | 2      | ×   | <a href="#">EC-1810</a> |
| P0198            | 0198  | EOT SEN/CIRC                    | —        | 2      | ×   | <a href="#">EC-1810</a> |
| P0201            | 0201  | INJECTOR CIRC-CYL1              | —        | 2      | ×   | <a href="#">EC-1812</a> |
| P0202            | 0202  | INJECTOR CIRC-CYL2              | —        | 2      | ×   | <a href="#">EC-1812</a> |
| P0203            | 0203  | INJECTOR CIRC-CYL3              | —        | 2      | ×   | <a href="#">EC-1812</a> |
| P0204            | 0204  | INJECTOR CIRC-CYL4              | —        | 2      | ×   | <a href="#">EC-1812</a> |
| P0205            | 0205  | INJECTOR CIRC-CYL5              | —        | 2      | ×   | <a href="#">EC-1812</a> |
| P0206            | 0206  | INJECTOR CIRC-CYL6              | —        | 2      | ×   | <a href="#">EC-1812</a> |
| P0207            | 0207  | INJECTOR CIRC-CYL7              | —        | 2      | ×   | <a href="#">EC-1812</a> |
| P0208            | 0208  | INJECTOR CIRC-CYL8              | —        | 2      | ×   | <a href="#">EC-1812</a> |
| P0222            | 0222  | TP SEN 1/CIRC-B1                | —        | 1      | ×   | <a href="#">EC-1813</a> |
| P0223            | 0223  | TP SEN 1/CIRC-B1                | —        | 1      | ×   | <a href="#">EC-1813</a> |
| P0227            | 0227  | TP SEN 2/CIRC-B2                | —        | 1      | ×   | <a href="#">EC-1759</a> |
| P0228            | 0228  | TP SEN 2/CIRC-B2                | —        | 1      | ×   | <a href="#">EC-1759</a> |
| P0300            | 0300  | MULTI CYL MISFIRE               | —        | 1 or 2 | ×   | <a href="#">EC-1816</a> |
| P0301            | 0301  | CYL 1 MISFIRE                   | —        | 1 or 2 | ×   | <a href="#">EC-1816</a> |
| P0302            | 0302  | CYL 2 MISFIRE                   | —        | 1 or 2 | ×   | <a href="#">EC-1816</a> |
| P0303            | 0303  | CYL 3 MISFIRE                   | —        | 1 or 2 | ×   | <a href="#">EC-1816</a> |
| P0304            | 0304  | CYL 4 MISFIRE                   | —        | 1 or 2 | ×   | <a href="#">EC-1816</a> |
| P0305            | 0305  | CYL 5 MISFIRE                   | —        | 1 or 2 | ×   | <a href="#">EC-1816</a> |
| P0306            | 0306  | CYL 6 MISFIRE                   | —        | 1 or 2 | ×   | <a href="#">EC-1816</a> |
| P0307            | 0307  | CYL 7 MISFIRE                   | —        | 1 or 2 | ×   | <a href="#">EC-1816</a> |
| P0308            | 0308  | CYL 8 MISFIRE                   | —        | 1 or 2 | ×   | <a href="#">EC-1816</a> |
| P0327            | 0327  | KNOCK SEN/CIRC-B1               | —        | 2      | —   | <a href="#">EC-1822</a> |
| P0328            | 0328  | KNOCK SEN/CIRC-B1               | —        | 2      | —   | <a href="#">EC-1822</a> |
| P0332            | 0332  | KNOCK SEN/CIRC-B2               | —        | 2      | —   | <a href="#">EC-1822</a> |
| P0333            | 0333  | KNOCK SEN/CIRC-B2               | —        | 2      | —   | <a href="#">EC-1822</a> |
| P0335            | 0335  | CKP SEN/CIRCUIT                 | —        | 2      | ×   | <a href="#">EC-1824</a> |
| P0340            | 0340  | CMP SEN/CIRC-B1                 | —        | 2      | ×   | <a href="#">EC-1828</a> |
| P0345            | 0345  | CMP SEN/CIRC-B2                 | —        | 2      | ×   | <a href="#">EC-1828</a> |
| P0420            | 0420  | TW CATALYST SYS-B1              | ×        | 2      | ×   | <a href="#">EC-1833</a> |
| P0430            | 0430  | TW CATALYST SYS-B2              | ×        | 2      | ×   | <a href="#">EC-1833</a> |
| P0444            | 0444  | PURG VOLUME CONT/V              | —        | 2      | ×   | <a href="#">EC-1838</a> |
| P0500            | 0500  | VEHICLE SPEED SEN A*5           | —        | 2      | ×   | <a href="#">EC-1841</a> |
| P0506            | 0506  | ISC SYSTEM                      | —        | 2      | ×   | <a href="#">EC-1843</a> |

A

EC

C

D

E

F

G

H

I

J

K

L

M

N

O

P

# ECM

< ECU DIAGNOSIS INFORMATION >

[VK56VD FOR MEXICO]

| DTC*1            |       | Items<br>(CONSULT screen terms) | SRT code | Trip   | MIL    | Reference<br>page       |
|------------------|-------|---------------------------------|----------|--------|--------|-------------------------|
| CONSULT<br>GST*2 | ECM*3 |                                 |          |        |        |                         |
| P0507            | 0507  | ISC SYSTEM                      | —        | 2      | ×      | <a href="#">EC-1845</a> |
| P0520            | 0520  | EOP SENSOR/SWITCH               | —        | 2      | —      | <a href="#">EC-1847</a> |
| P0524            | 0524  | ENGINE OIL PRESSURE             | —        | 2      | ×      | <a href="#">EC-1850</a> |
| P0550            | 0550  | PW ST P SEN/CIRC                | —        | 2      | —      | <a href="#">EC-1853</a> |
| P0603            | 0603  | ECM BACK UP/CIRCUIT             | —        | 2      | ×      | <a href="#">EC-1856</a> |
| P0605            | 0605  | ECM                             | —        | 1 or 2 | × or — | <a href="#">EC-1858</a> |
| P0607            | 0607  | ECM                             | —        | 1      | ×      | <a href="#">EC-1860</a> |
| P0611            | 0611  | FIC MODULE                      | —        | 2      | —      | <a href="#">EC-1861</a> |
| P062B            | 062B  | ECM                             | —        | 2      | × or — | <a href="#">EC-1862</a> |
| P0643            | 0643  | SENSOR POWER/CIRC               | —        | 1      | ×      | <a href="#">EC-1863</a> |
| P0705            | 0705  | T/M RANGE SENSOR A              | —        | 2      | ×      | <a href="#">TM-102</a>  |
| P0710            | 0710  | FLUID TEMP SENSOR A*7           | —        | 2      | ×      | <a href="#">TM-103</a>  |
| P0717            | 0717  | INPUT SPEED SENSOR A            | —        | 2      | ×      | <a href="#">TM-105</a>  |
| P0720            | 0720  | OUTPUT SPEED SENSOR*5           | —        | 2      | ×      | <a href="#">TM-106</a>  |
| P0729            | 0729  | 6GR INCORRECT RATIO*7           | —        | 2      | ×      | <a href="#">TM-110</a>  |
| P0730            | 0730  | INCORRECT GR RATIO              | —        | 2      | ×      | <a href="#">TM-112</a>  |
| P0731            | 0731  | 1GR INCORRECT RATIO*7           | —        | 2      | ×      | <a href="#">TM-114</a>  |
| P0732            | 0732  | 2GR INCORRECT RATIO*7           | —        | 2      | ×      | <a href="#">TM-116</a>  |
| P0733            | 0733  | 3GR INCORRECT RATIO*7           | —        | 2      | ×      | <a href="#">TM-118</a>  |
| P0734            | 0734  | 4GR INCORRECT RATIO*7           | —        | 2      | ×      | <a href="#">TM-120</a>  |
| P0735            | 0735  | 5GR INCORRECT RATIO*7           | —        | 2      | ×      | <a href="#">TM-122</a>  |
| P0740            | 0740  | TORQUE CONVERTER                | —        | 2      | ×      | <a href="#">TM-124</a>  |
| P0744            | 0744  | TORQUE CONVERTER                | —        | 2      | ×      | <a href="#">TM-125</a>  |
| P0745            | 0745  | PC SOLENOID A                   | —        | 2      | ×      | <a href="#">TM-127</a>  |
| P0750            | 0750  | SHIFT SOLENOID A                | —        | 2      | ×      | <a href="#">TM-128</a>  |
| P0775            | 0775  | PC SOLENOID B                   | —        | 2      | ×      | <a href="#">TM-129</a>  |
| P0780            | 0780  | SHIFT                           | —        | 1      | ×      | <a href="#">TM-130</a>  |
| P0795            | 0795  | PC SOLENOID C                   | —        | 2      | ×      | <a href="#">TM-132</a>  |
| P0850            | 0850  | P-N POS SW/CIRCUIT              | —        | 2      | ×      | <a href="#">EC-1865</a> |
| P100A            | 100A  | VVEL SYSTEM-B1                  | —        | 2      | ×      | <a href="#">EC-1868</a> |
| P100B            | 100B  | VVEL SYSTEM-B2                  | —        | 2      | —      | <a href="#">EC-1868</a> |
| P1078            | 1078  | EXH TIM SEN/CIRC-B1             | —        | 2      | ×      | <a href="#">EC-1872</a> |
| P1084            | 1084  | EXH TIM SEN/CIRC-B2             | —        | 2      | ×      | <a href="#">EC-1872</a> |
| P1087            | 1087  | VVEL SYSTEM-B1                  | —        | 1      | ×      | <a href="#">EC-1875</a> |
| P1088            | 1088  | VVEL SYSTEM-B2                  | —        | 1      | ×      | <a href="#">EC-1875</a> |
| P1089            | 1089  | VVEL POS SEN/CIRC-B1            | —        | 1      | ×      | <a href="#">EC-1876</a> |
| P1090            | 1090  | VVEL ACTR MOT-B1                | —        | 1      | ×      | <a href="#">EC-1879</a> |
| P1091            | 1091  | VVEL ACTR MOT PWR               | —        | 1 or 2 | ×      | <a href="#">EC-1882</a> |
| P1092            | 1092  | VVEL POS SEN/CIRC-B2            | —        | 1      | ×      | <a href="#">EC-1876</a> |
| P1093            | 1093  | VVEL ACTR MOT-B2                | —        | 1      | ×      | <a href="#">EC-1879</a> |
| P1197            | 1197  | FUEL RUN OUT                    | —        | 2      | —      | <a href="#">EC-1810</a> |

# ECM

< ECU DIAGNOSIS INFORMATION >

[VK56VD FOR MEXICO]

| DTC*1         |       | Items<br>(CONSULT screen terms) | SRT code | Trip   | MIL    | Reference page          |
|---------------|-------|---------------------------------|----------|--------|--------|-------------------------|
| CONSULT GST*2 | ECM*3 |                                 |          |        |        |                         |
| P1212         | 1212  | TCS/CIRC                        | —        | 2      | —      | <a href="#">EC-1887</a> |
| P1217         | 1217  | ENG OVER TEMP                   | —        | 1      | ×      | <a href="#">EC-1888</a> |
| P1225         | 1225  | CTP LEARNING-B1                 | —        | 2      | —      | <a href="#">EC-1891</a> |
| P1226         | 1226  | CTP LEARNING-B1                 | —        | 2      | —      | <a href="#">EC-1892</a> |
| P1233         | 1233  | ETC FNCTN/CIRC-B2               | —        | 1      | ×      | <a href="#">EC-1893</a> |
| P1234         | 1234  | CTP LEARNING-B2                 | —        | 2      | —      | <a href="#">EC-1891</a> |
| P1235         | 1235  | CTP LEARNING-B2                 | —        | 2      | —      | <a href="#">EC-1892</a> |
| P1236         | 1236  | ETC MOT-B2                      | —        | 1      | ×      | <a href="#">EC-1897</a> |
| P1238         | 1238  | ETC ACTR-B2                     | —        | 1      | ×      | <a href="#">EC-1899</a> |
| P1239         | 1239  | TP SENSOR-B2                    | —        | 1      | ×      | <a href="#">EC-1901</a> |
| P1550         | 1550  | BAT CURRENT SENSOR              | —        | 2      | —      | <a href="#">EC-1904</a> |
| P1551         | 1551  | BAT CURRENT SENSOR              | —        | 2      | —      | <a href="#">EC-1908</a> |
| P1552         | 1552  | BAT CURRENT SENSOR              | —        | 2      | —      | <a href="#">EC-1908</a> |
| P1553         | 1553  | BAT CURRENT SENSOR              | —        | 2      | —      | <a href="#">EC-1912</a> |
| P1554         | 1554  | BAT CURRENT SENSOR              | —        | 2      | —      | <a href="#">EC-1916</a> |
| P1556         | 1556  | BAT TMP SEN/CIRC                | —        | 2      | —      | <a href="#">EC-1920</a> |
| P1557         | 1557  | BAT TMP SEN/CIRC                | —        | 2      | —      | <a href="#">EC-1920</a> |
| P1564         | 1564  | ASCD SW                         | —        | 1      | —      | <a href="#">EC-1926</a> |
| P1568         | 1568  | ICC COMMAND VALUE               | —        | 1      | —      | <a href="#">EC-1929</a> |
| P1572         | 1572  | ASCD BRAKE SW                   | —        | 1      | —      | <a href="#">EC-1930</a> |
| P1574         | 1574  | ASCD VHL SPD SEN                | —        | 1      | —      | <a href="#">EC-1938</a> |
| P1606         | 1606  | VVEL CONTROL MODULE             | —        | 1 or 2 | × or — | <a href="#">EC-1940</a> |
| P1607         | 1607  | VVEL CONTROL MODULE             | —        | 1      | ×      | <a href="#">EC-1941</a> |
| P1608         | 1608  | VVEL SENSOR POWER/CIRC          | —        | 1      | ×      | <a href="#">EC-1942</a> |
| P1610         | 1610  | LOCK MODE                       | —        | 2      | —      | <a href="#">SEC-41</a>  |
| P1611         | 1611  | ID DISCORD IMMU-ECM             | —        | 2      | —      | <a href="#">SEC-42</a>  |
| P1612         | 1612  | CHAIN OF ECM-IMMU               | —        | 2      | —      | <a href="#">SEC-43</a>  |
| P1614         | 1614  | CHAIN OF IMMU-KEY               | —        | 2      | —      | <a href="#">SEC-44</a>  |
| P1715         | 1715  | IN PULY SPEED                   | —        | 2      | —      | <a href="#">EC-1944</a> |
| P1730         | 1730  | INTERLOCK                       | —        | 2      | ×      | <a href="#">TM-136</a>  |
| P1734         | 1734  | 7GR INCORRECT RATIO*7           | —        | 2      | ×      | <a href="#">TM-138</a>  |
| P1805         | 1805  | BRAKE SW/CIRCUIT                | —        | 2      | —      | <a href="#">EC-1945</a> |
| P1806         | 1806  | BRAKE VACUUM SEN                | —        | 2      | ×      | <a href="#">BRC-111</a> |
| P2100         | 2100  | ETC MOT PWR-B1                  | —        | 1      | ×      | <a href="#">EC-1948</a> |
| P2101         | 2101  | ETC FNCTN/CIRC-B1               | —        | 1      | ×      | <a href="#">EC-1893</a> |
| P2103         | 2103  | ETC MOT PWR                     | —        | 1      | ×      | <a href="#">EC-1948</a> |
| P2118         | 2118  | ETC MOT-B1                      | —        | 1      | ×      | <a href="#">EC-1897</a> |
| P2119         | 2119  | ETC ACTR-B1                     | —        | 1      | ×      | <a href="#">EC-1899</a> |
| P2122         | 2122  | APP SEN 1/CIRC                  | —        | 1      | ×      | <a href="#">EC-1950</a> |
| P2123         | 2123  | APP SEN 1/CIRC                  | —        | 1      | ×      | <a href="#">EC-1950</a> |
| P2127         | 2127  | APP SEN 2/CIRC                  | —        | 1      | ×      | <a href="#">EC-1953</a> |
| P2128         | 2128  | APP SEN 2/CIRC                  | —        | 1      | ×      | <a href="#">EC-1953</a> |

A

EC

C

D

E

F

G

H

I

J

K

L

M

N

O

P

# ECM

< ECU DIAGNOSIS INFORMATION >

[VK56VD FOR MEXICO]

| DTC*1            |       | Items<br>(CONSULT screen terms) | SRT code | Trip | MIL | Reference<br>page       |
|------------------|-------|---------------------------------|----------|------|-----|-------------------------|
| CONSULT<br>GST*2 | ECM*3 |                                 |          |      |     |                         |
| P2132            | 2132  | TP SEN 1/CIRC-B2                | —        | 1    | ×   | <a href="#">EC-1813</a> |
| P2133            | 2133  | TP SEN 1/CIRC-B2                | —        | 1    | ×   | <a href="#">EC-1813</a> |
| P2135            | 2135  | TP SENSOR-B1                    | —        | 1    | ×   | <a href="#">EC-1901</a> |
| P2138            | 2138  | APP SENSOR                      | —        | 1    | ×   | <a href="#">EC-1957</a> |
| P2539            | 2539  | LOW FUEL PRES SEN               | —        | 2    | ×   | <a href="#">EC-1962</a> |
| P2713            | 2713  | PC SOLENOID D                   | —        | 2    | ×   | <a href="#">TM-146</a>  |
| P2722            | 2722  | PC SOLENOID E                   | —        | 2    | ×   | <a href="#">TM-147</a>  |
| P2731            | 2731  | PC SOLENOID F                   | —        | 2    | ×   | <a href="#">TM-148</a>  |
| P2807            | 2807  | PC SOLENOID G                   | —        | 2    | ×   | <a href="#">TM-149</a>  |

\*1: 1st trip DTC No. is the same as DTC No.

\*2: This number is prescribed by SAE J2012/ISO 15031-6.

\*3: In Diagnostic Test Mode II (Self-diagnostic results), this number is controlled by NISSAN.

\*4: The troubleshooting for this DTC needs CONSULT.

\*5: When the fail safe operations for both self-diagnoses occur, the MIL illuminates.

\*6: When the ECM is in the mode that displays SRT status, MIL may blink. For the details, refer to "How to Display SRT Status".

\*7: When erasing this DTC, always use CONSULT or GST.

## Test Value and Test Limit

INFOID:000000007758182

The following is the information specified in Service \$06 of SAE J1979/ISO 15031-5.

The test value is a parameter used to determine whether a system/circuit diagnostic test is OK or NG while being monitored by the ECM during self-diagnosis. The test limit is a reference value which is specified as the maximum or minimum value and is compared with the test value being monitored.

These data (test value and test limit) are specified by On Board Monitor ID (OBDMID), Test ID (TID), Unit and Scaling ID and can be displayed on the GST screen.

The items of the test value and test limit will be displayed with GST screen which items are provided by the ECM. (e.g., if bank 2 is not applied on this vehicle, only the items of bank 1 are displayed)



**ECM**

< ECU DIAGNOSIS INFORMATION >

**[VK56VD FOR MEXICO]**

| Item | OBD-MID | Self-diagnostic test item              | DTC   | Test value and Test limit (GST display) |                     | Description   |
|------|---------|--|-------|---|---------------------|---|
|      |         |  |       | TID                                     | Unit and Scaling ID |   |
| HO2S | 01H     | Air fuel ratio (A/F) sensor 1 (Bank 1) | P0131 | 83H                                     | 0BH                 | Minimum sensor output voltage for test cycle              |
|      |         |  | P0131 | 84H                                     | 0BH                 | Maximum sensor output voltage for test cycle              |
|      |         |  | P0130 | 85H                                     | 0BH                 | Minimum sensor output voltage for test cycle              |
|      |         |  | P0130 | 86H                                     | 0BH                 | Maximum sensor output voltage for test cycle              |
|      |         |  | P0133 | 87H                                     | 04H                 | Response rate: Response ratio (lean to rich)              |
|      |         |  | P0133 | 88H                                     | 04H                 | Response rate: Response ratio (rich to lean)              |
|      |         |  | P2A00 | 89H                                     | 84H                 | The amount of shift in air fuel ratio                     |
|      |         |  | P2A00 | 8AH                                     | 84H                 | The amount of shift in air fuel ratio                     |
|      |         |  | P0130 | 8BH                                     | 0BH                 | Difference in sensor output voltage                       |
|      |         |  | P0133 | 8CH                                     | 83H                 | Response gain at the limited frequency                    |
|      |         |  | P014C | 8DH                                     | 04H                 | O2 sensor slow response - Rich to lean bank 1 sensor 1    |
|      |         |  | P014C | 8EH                                     | 04H                 | O2 sensor slow response - Rich to lean bank 1 sensor 1    |
|      |         |  | P014D | 8FH                                     | 84H                 | O2 sensor slow response - Lean to rich bank 1 sensor 1    |
|      |         |  | P014D | 90H                                     | 84H                 | O2 sensor slow response - Lean to rich bank 1 sensor 1    |
|      |         |  | P015A | 91H                                     | 01H                 | O2 sensor delayed response - Rich to lean bank 1 sensor 1 |
|      |         |  | P015A | 92H                                     | 01H                 | O2 sensor delayed response - Rich to lean bank 1 sensor 1 |
|      |         |  | P015B | 93H                                     | 01H                 | O2 sensor delayed response - Lean to rich bank 1 sensor 1 |
|      |         |  | P015B | 94H                                     | 01H                 | O2 sensor delayed response - Lean to rich bank 1 sensor 1 |
|      | 02H     | Heated oxygen sensor 2 (Bank 1)        | P0138 | 07H                                     | 0CH                 | Minimum sensor output voltage for test cycle              |
|      |         |  | P0137 | 08H                                     | 0CH                 | Maximum sensor output voltage for test cycle              |
|      |         |  | P0138 | 80H                                     | 0CH                 | Sensor output voltage                                     |
|      |         |  | P0139 | 81H                                     | 0CH                 | Difference in sensor output voltage                       |
|      | 03H     | Heated oxygen sensor 3 (Bank 1)        | P0143 | 07H                                     | 0CH                 | Minimum sensor output voltage for test cycle              |
|      |         |  | P0144 | 08H                                     | 0CH                 | Maximum sensor output voltage for test cycle              |
|      |         |  | P0146 | 80H                                     | 0CH                 | Sensor output voltage                                     |
|      |         |  | P0145 | 81H                                     | 0CH                 | Difference in sensor output voltage                       |

A

EC

C

D

E

F

G

H

I

J

K

L

M

N

O

P

# ECM

< ECU DIAGNOSIS INFORMATION >

[VK56VD FOR MEXICO]

| Item | OBD-MID | Self-diagnostic test item              | DTC   | Test value and Test limit (GST display)                   |                     | Description   |
|------|---------|--|-------|---|---------------------|---|
|      |         |  |       | TID   | Unit and Scaling ID |   |
| HO2S | 05H     | Air fuel ratio (A/F) sensor 1 (Bank 2) | P0151 | 83H   | 0BH                 | Minimum sensor output voltage for test cycle              |
|      |         |  | P0151 | 84H   | 0BH                 | Maximum sensor output voltage for test cycle              |
|      |         |  | P0150 | 85H   | 0BH                 | Minimum sensor output voltage for test cycle              |
|      |         |  | P0150 | 86H   | 0BH                 | Maximum sensor output voltage for test cycle              |
|      |         |  | P0153 | 87H   | 04H                 | Response rate: Response ratio (lean to rich)              |
|      |         |  | P0153 | 88H   | 04H                 | Response rate: Response ratio (rich to lean)              |
|      |         |  | P2A03 | 89H   | 84H                 | The amount of shift in air fuel ratio                     |
|      |         |  | P2A03 | 8AH   | 84H                 | The amount of shift in air fuel ratio                     |
|      |         |  | P0150 | 8BH   | 0BH                 | Difference in sensor output voltage                       |
|      |         |  | P0153 | 8CH   | 83H                 | Response gain at the limited frequency                    |
|      |         |  | P014E | 8DH   | 04H                 | O2 sensor slow response - Rich to lean bank 2 sensor 1    |
|      |         |  | P014E | 8EH   | 04H                 | O2 sensor slow response - Rich to lean bank 2 sensor 1    |
|      |         |  | P014F | 8FH   | 84H                 | O2 sensor slow response - Lean to rich bank 2 sensor 1    |
|      |         |  | P014F | 90H   | 84H                 | O2 sensor slow response - Lean to rich bank 2 sensor 1    |
|      |         |  | P015C | 91H   | 01H                 | O2 sensor delayed response - Rich to lean bank 2 sensor 1 |
|      |         |  | P015C | 92H   | 01H                 | O2 sensor delayed response - Rich to lean bank 2 sensor 1 |
|      | P015D   | 93H                                    | 01H   | O2 sensor delayed response - Lean to rich bank 2 sensor 1 |                     |   |
|      | P015D   | 94H                                    | 01H   | O2 sensor delayed response - Lean to rich bank 2 sensor 1 |                     |   |
|      | 06H     | Heated oxygen sensor 2 (Bank 2)        | P0158 | 07H   | 0CH                 | Minimum sensor output voltage for test cycle              |
|      |         |  | P0157 | 08H   | 0CH                 | Maximum sensor output voltage for test cycle              |
|      |         |  | P0158 | 80H   | 0CH                 | Sensor output voltage                                     |
|      |         |  | P0159 | 81H   | 0CH                 | Difference in sensor output voltage                       |
|      | 07H     | Heated oxygen sensor 3 (Bank2)         | P0163 | 07H   | 0CH                 | Minimum sensor output voltage for test cycle              |
|      |         |  | P0164 | 08H   | 0CH                 | Maximum sensor output voltage for test cycle              |
|      |         |  | P0166 | 80H   | 0CH                 | Sensor output voltage                                     |
|      |         |  | P0165 | 81H   | 0CH                 | Difference in sensor output voltage                       |

# ECM

< ECU DIAGNOSIS INFORMATION >

[VK56VD FOR MEXICO]

| Item          | OBD-MID | Self-diagnostic test item           | DTC   | Test value and Test limit (GST display) |                     | Description  |
|---------------|---------|-------------------------------------|-------|---|---------------------|--|
|               |         |                                     |       | TID                                     | Unit and Scaling ID |  |
| CATA-<br>LYST | 21H     | Three way catalyst function (Bank1) | P0420 | 80H                                     | 01H                 | O2 storage index   |
|               |         |                                     | P0420 | 82H                                     | 01H                 | Switching time lag engine exhaust index value  |
|               |         |                                     | P2423 | 83H                                     | 0CH                 | Difference in 3rd O2 sensor output voltage   |
|               |         |                                     | P2423 | 84H                                     | 84H                 | O2 storage index in HC trap catalyst   |
|               | 22H     | Three way catalyst function (Bank2) | P0430 | 80H                                     | 01H                 | O2 storage index   |
|               |         |                                     | P0430 | 82H                                     | 01H                 | Switching time lag engine exhaust index value  |
|               |         |                                     | P2424 | 83H                                     | 0CH                 | Difference in 3rd O2 sensor output voltage   |
|               |         |                                     | P2424 | 84H                                     | 84H                 | O2 storage index in HC trap catalyst   |
| EGR<br>SYSTEM | 31H     | EGR function                        | P0400 | 80H                                     | 96H                 | Low flow faults: EGR temp change rate (short term)                                   |
|               |         |                                     | P0400 | 81H                                     | 96H                 | Low flow faults: EGR temp change rate (long term)                                    |
|               |         |                                     | P0400 | 82H                                     | 96H                 | Low flow faults: Difference between max EGR temp and EGR temp under idling condition |
|               |         |                                     | P0400 | 83H                                     | 96H                 | Low flow faults: Max EGR temp  |
|               |         |                                     | P1402 | 84H                                     | 96H                 | High Flow Faults: EGR temp increase rate   |
| VVT<br>SYSTEM | 35H     | VVT Monitor (Bank1)                 | P0011 | 80H                                     | 9DH                 | VTC intake function diagnosis (VTC alignment check diagnosis)                        |
|               |         |                                     | P0014 | 81H                                     | 9DH                 | VTC exhaust function diagnosis (VTC alignment check diagnosis)                       |
|               |         |                                     | P0011 | 82H                                     | 9DH                 | VTC intake function diagnosis (VTC drive failure diagnosis)                          |
|               |         |                                     | P0014 | 83H                                     | 9DH                 | VTC exhaust function diagnosis (VTC drive failure diagnosis)                         |
|               | 36H     | VVT Monitor (Bank2)                 | P0021 | 80H                                     | 9DH                 | VTC intake function diagnosis (VTC alignment check diagnosis)                        |
|               |         |                                     | P0024 | 81H                                     | 9DH                 | VTC exhaust function diagnosis (VTC alignment check diagnosis)                       |
|               |         |                                     | P0021 | 82H                                     | 9DH                 | VTC intake function diagnosis (VTC drive failure diagnosis)                          |
|               |         |                                     | P0024 | 83H                                     | 9DH                 | VTC exhaust function diagnosis (VTC drive failure diagnosis)                         |

A  
EC  
C  
D  
E  
F  
G  
H  
I  
J  
K  
L  
M  
N  
O  
P

# ECM

< ECU DIAGNOSIS INFORMATION >

[VK56VD FOR MEXICO]

| Item             | OBD-MID | Self-diagnostic test item                  | DTC                                   | Test value and Test limit (GST display) |                     | Description  |
|------------------|---------|--|---------------------------------------|---|---------------------|--|
|                  |         |  |                                       | TID                                     | Unit and Scaling ID |  |
| EVAP SYSTEM      | 39H     | EVAP control system leak (Cap Off)         | P0455                                 | 80H                                     | 0CH                 | Difference in pressure sensor output voltage before and after pull down                |
|                  | 3BH     | EVAP control system leak (Small leak)      | P0442                                 | 80H                                     | 05H                 | Leak area index (for more than 0.04 inch)  |
|                  | 3CH     | EVAP control system leak (Very small leak) | P0456                                 | 80H                                     | 05H                 | Leak area index (for more than 0.02 inch)  |
|                  |         |  | P0456                                 | 81H                                     | FDH                 | Maximum internal pressure of EVAP system during monitoring                             |
|                  |         |  | P0456                                 | 82H                                     | FDH                 | Internal pressure of EVAP system at the end of monitoring                              |
|                  | 3DH     | Purge flow system                          | P0441                                 | 83H                                     | 0CH                 | Difference in pressure sensor output voltage before and after vent control valve close |
| O2 SENSOR HEATER | 41H     | A/F sensor 1 heater (Bank 1)               | Low Input: P0031<br>High Input: P0032 | 81H                                     | 0BH                 | Converted value of heater electric current to voltage                                  |
|                  | 42H     | Heated oxygen sensor 2 heater (Bank 1)     | Low Input: P0037<br>High Input: P0038 | 80H                                     | 0CH                 | Converted value of heater electric current to voltage                                  |
|                  | 43H     | Heated oxygen sensor 3 heater (Bank 1)     | P0043                                 | 80H                                     | 0CH                 | Converted value of heater electric current to voltage                                  |
|                  | 45H     | A/F sensor 1 heater (Bank 2)               | Low Input: P0051<br>High Input: P0052 | 81H                                     | 0BH                 | Converted value of heater electric current to voltage                                  |
|                  | 46H     | Heated oxygen sensor 2 heater (Bank 2)     | Low Input: P0057<br>High Input: P0058 | 80H                                     | 0CH                 | Converted value of heater electric current to voltage                                  |
|                  | 47H     | Heated oxygen sensor 3 heater (Bank 2)     | P0063                                 | 80H                                     | 0CH                 | Converted value of heater electric current to voltage                                  |
| SECONDARY AIR    | 71H     | Secondary air system                       | P0411                                 | 80H                                     | 01H                 | Secondary air injection system incorrect flow detected                                 |
|                  |         |  | Bank1: P0491<br>Bank2: P0492          | 81H                                     | 01H                 | Secondary air injection system insufficient flow                                       |
|                  |         |  | P2445                                 | 82H                                     | 01H                 | Secondary air injection system pump stuck off  |
|                  |         |  | P2448                                 | 83H                                     | 01H                 | Secondary air injection system high airflow  |
|                  |         |  | Bank1: P2440<br>Bank2: P2442          | 84H                                     | 01H                 | Secondary air injection system switching valve stuck open                              |
|                  |         |  | P2440                                 | 85H                                     | 01H                 | Secondary air injection system switching valve stuck open                              |
|                  |         |  | P2444                                 | 86H                                     | 01H                 | Secondary air injection system pump stuck on   |
| FUEL SYSTEM      | 81H     | Fuel injection system function (Bank 1)    | P0171 or P0172                        | 80H                                     | 2FH                 | Long term fuel trim  |
|                  |         |  | P0171 or P0172                        | 81H                                     | 24H                 | The number of lambda control clamped   |
|                  | 82H     | Fuel injection system function (Bank 2)    | P0174 or P0175                        | 80H                                     | 2FH                 | Long term fuel trim  |
|                  |         |  | P0174 or P0175                        | 81H                                     | 24H                 | The number of lambda control clamped   |

# ECM

< ECU DIAGNOSIS INFORMATION >

[VK56VD FOR MEXICO]

| Item    | OBD-MID | Self-diagnostic test item  | DTC   | Test value and Test limit (GST display) |                     | Description  |
|---------|---------|----------------------------|-------|---|---------------------|--|
|         |         |                            |       | TID                                     | Unit and Scaling ID |  |
| MISFIRE | A1H     | Multiple cylinder misfires | P0301 | 80H                                     | 24H                 | Misfiring counter at 1000 revolution of the first cylinder     |
|         |         |                            | P0302 | 81H                                     | 24H                 | Misfiring counter at 1000 revolution of the second cylinder    |
|         |         |                            | P0303 | 82H                                     | 24H                 | Misfiring counter at 1000 revolution of the third cylinder     |
|         |         |                            | P0304 | 83H                                     | 24H                 | Misfiring counter at 1000 revolution of the fourth cylinder    |
|         |         |                            | P0305 | 84H                                     | 24H                 | Misfiring counter at 1000 revolution of the fifth cylinder     |
|         |         |                            | P0306 | 85H                                     | 24H                 | Misfiring counter at 1000 revolution of the sixth cylinder     |
|         |         |                            | P0307 | 86H                                     | 24H                 | Misfiring counter at 1000 revolution of the seventh cylinder   |
|         |         |                            | P0308 | 87H                                     | 24H                 | Misfiring counter at 1000 revolution of the eighth cylinder    |
|         |         |                            | P0300 | 88H                                     | 24H                 | Misfiring counter at 1000 revolution of the multiple cylinders |
|         |         |                            | P0301 | 89H                                     | 24H                 | Misfiring counter at 200 revolution of the first cylinder      |
|         |         |                            | P0302 | 8AH                                     | 24H                 | Misfiring counter at 200 revolution of the second cylinder     |
|         |         |                            | P0303 | 8BH                                     | 24H                 | Misfiring counter at 200 revolution of the third cylinder      |
|         |         |                            | P0304 | 8CH                                     | 24H                 | Misfiring counter at 200 revolution of the fourth cylinder     |
|         |         |                            | P0305 | 8DH                                     | 24H                 | Misfiring counter at 200 revolution of the fifth cylinder      |
|         |         |                            | P0306 | 8EH                                     | 24H                 | Misfiring counter at 200 revolution of the sixth cylinder      |
|         |         |                            | P0307 | 8FH                                     | 24H                 | Misfiring counter at 200 revolution of the seventh cylinder    |
|         |         |                            | P0308 | 90H                                     | 24H                 | Misfiring counter at 200 revolution of the eighth cylinder     |
|         |         |                            | P0300 | 91H                                     | 24H                 | Misfiring counter at 1000 revolution of the single cylinder    |
|         |         |                            | P0300 | 92H                                     | 24H                 | Misfiring counter at 200 revolution of the single cylinder     |
|         |         |                            | P0300 | 93H                                     | 24H                 | Misfiring counter at 200 revolution of the multiple cylinders  |

A  
EC  
C  
D  
E  
F  
G  
H  
I  
J  
K  
L  
M  
N  
O  
P

# ECM

< ECU DIAGNOSIS INFORMATION >

[VK56VD FOR MEXICO]

| Item    | OBD-MID | Self-diagnostic test item | DTC   | Test value and Test limit (GST display) |                     | Description  |
|---------|---------|---------------------------|-------|---|---------------------|--|
|         |         |                           |       | TID                                     | Unit and Scaling ID |  |
| MISFIRE | A2H     | No. 1 cylinder misfire    | P0301 | 0BH                                     | 24H                 | EWMA (Exponential Weighted Moving Average) misfire counts for last 10 driving cycles |
|         |         |                           | P0301 | 0CH                                     | 24H                 | Misfire counts for last/current driving cycles                                       |
|         | A3H     | No. 2 cylinder misfire    | P0302 | 0BH                                     | 24H                 | EWMA (Exponential Weighted Moving Average) misfire counts for last 10 driving cycles |
|         |         |                           | P0302 | 0CH                                     | 24H                 | Misfire counts for last/current driving cycles                                       |
|         | A4H     | No. 3 cylinder misfire    | P0303 | 0BH                                     | 24H                 | EWMA (Exponential Weighted Moving Average) misfire counts for last 10 driving cycles |
|         |         |                           | P0303 | 0CH                                     | 24H                 | Misfire counts for last/current driving cycles                                       |
|         | A5H     | No. 4 cylinder misfire    | P0304 | 0BH                                     | 24H                 | EWMA (Exponential Weighted Moving Average) misfire counts for last 10 driving cycles |
|         |         |                           | P0304 | 0CH                                     | 24H                 | Misfire counts for last/current driving cycles                                       |
|         | A6H     | No. 5 cylinder misfire    | P0305 | 0BH                                     | 24H                 | EWMA (Exponential Weighted Moving Average) misfire counts for last 10 driving cycles |
|         |         |                           | P0305 | 0CH                                     | 24H                 | Misfire counts for last/current driving cycles                                       |
|         | A7H     | No. 6 cylinder misfire    | P0306 | 0BH                                     | 24H                 | EWMA (Exponential Weighted Moving Average) misfire counts for last 10 driving cycles |
|         |         |                           | P0306 | 0CH                                     | 24H                 | Misfire counts for last/current driving cycles                                       |
|         | A8H     | No. 7 cylinder misfire    | P0307 | 0BH                                     | 24H                 | EWMA (Exponential Weighted Moving Average) misfire counts for last 10 driving cycles |
|         |         |                           | P0307 | 0CH                                     | 24H                 | Misfire counts for last/current driving cycles                                       |
|         | A9H     | No. 8 cylinder misfire    | P0308 | 0BH                                     | 24H                 | EWMA (Exponential Weighted Moving Average) misfire counts for last 10 driving cycles |
|         |         |                           | P0308 | 0CH                                     | 24H                 | Misfire counts for last/current driving cycles                                       |

# VVEL CONTROL MODULE

< ECU DIAGNOSIS INFORMATION >

[VK56VD FOR MEXICO]

## VVEL CONTROL MODULE

### Reference Value

INFOID:000000007758183

### TERMINAL LAYOUT

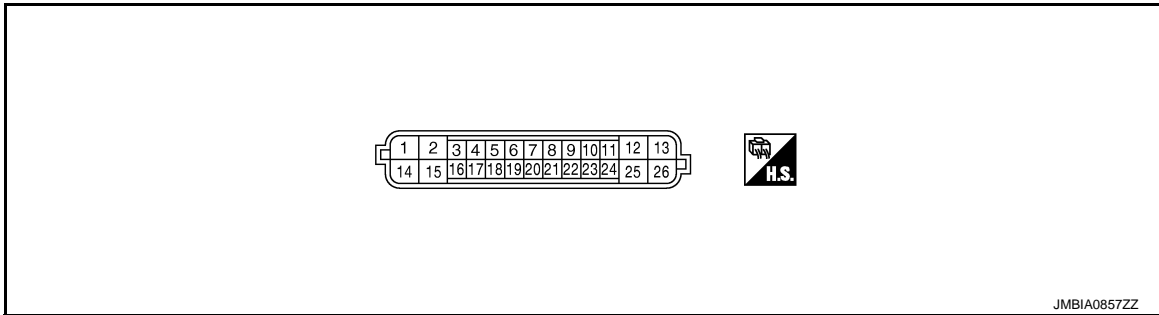

### PHYSICAL VALUES

#### NOTE:

- VVEL control module is located under the battery. Temporarily remove the battery to check voltage of the terminals.
- Specification data are reference values and are measured between each terminals.
- Pulse signal is measured by CONSULT.

| Terminal No. |          | Description   |              | Condition   | Value (Approx.)            |
|--------------|----------|---|--------------|---|----------------------------|
| +            | -        | Signal name   | Input/Output |   |                            |
| 1 (W)        | 14 (B/R) | VVEL actuator motor power supply (bank 2)                     | Input        | [Ignition switch: ON]   | BATTERY VOLTAGE (11 - 14V) |
| 2 (L/B)      | 14 (B/R) | VVEL actuator motor (High lift) (bank 2)                      | Output       | [Engine is running]<br>• Warm-up condition<br>• Idle speed                                  | 0 - 14 V★<br>              |
|              |          |   |              | [Engine is running]<br>• Warm-up condition<br>• When revving engine up to 2,000 rpm quickly | 0 - 14 V★<br>              |
| 3 (Y)        | 6 (B)    | VVEL control shaft position sensor 1 (bank 1)                 | Input        | [Engine is running]<br>• Warm-up condition<br>• Idle speed                                  | 0.25 - 1.40 V              |
|              |          |   |              | [Engine is running]<br>• Warm-up condition<br>• When revving engine up to 3,000 rpm quickly | 0.25 - 4.75 V              |
| 4 (W)        | —        | Sensor ground [VVEL control shaft position sensor 1 (bank 2)] | —            | —   | —                          |

# VVEL CONTROL MODULE

< ECU DIAGNOSIS INFORMATION >

[VK56VD FOR MEXICO]

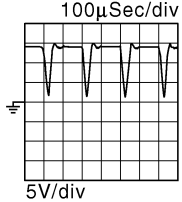
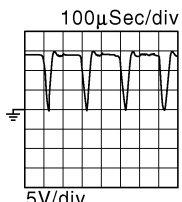
| Terminal No. |             | Description   |              | Condition   | Value (Approx.)  |
|--------------|-------------|---|--------------|---|--|
| +            | -           | Signal name   | Input/Output |   |  |
| 5<br>(L)     | 4<br>(W)    | VVEL control shaft position sensor 1 (bank 2)                       | Input        | [Engine is running]<br>• Warm-up condition<br>• Idle speed                                  | 0.25 - 1.40 V  |
|              |             |   |              | [Engine is running]<br>• Warm-up condition<br>• When revving engine up to 3,000 rpm quickly | 0.25 - 4.75 V  |
| 6<br>(B)     | —           | Sensor ground [VVEL control shaft position sensor 1 (bank 1)]       | —            | —   | —  |
| 7<br>(W)     | 6<br>(B)    | Sensor power supply [VVEL control shaft position sensor 1 (bank 1)] | —            | [Ignition switch: ON]   | 5 V  |
| 8<br>(R)     | 14<br>(B/R) | Power supply for VVEL control module                                | —            | [Ignition switch: ON]   | BATTERY VOLTAGE (11 - 14 V)  |
| 9<br>(B)     | 4<br>(W)    | Sensor power supply [VVEL position sensor 1 (bank 2)]               | —            | [Ignition switch: ON]   | 5 V  |
| 11<br>(GR)   | —           | ENG communication line  | Input/Output | —   | —  |
| 12<br>(L/B)  | 14<br>(B/R) | VVEL actuator motor (High lift) (bank 1)                            | Output       | [Engine is running]<br>• Warm-up condition<br>• Idle speed                                  | 0 - 14 V★<br>  |
|              |             |   |              | [Engine is running]<br>• Warm-up condition<br>• When revving engine up to 3,000 rpm quickly | 0 - 14 V★<br> |
| 13<br>(W)    | 14<br>(B/R) | VVEL actuator motor power supply (bank 1)                           | Input        | [Ignition switch: ON]   | BATTERY VOLTAGE (11 - 14 V)  |
| 14<br>(B/R)  | —           | VVEL control module ground  | —            | —   | —  |



# VVEL CONTROL MODULE

< ECU DIAGNOSIS INFORMATION >

[VK56VD FOR MEXICO]

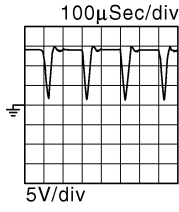
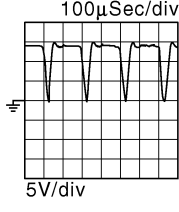
| Terminal No. |             | Description  |              | Condition   | Value (Approx.)  |
|--------------|-------------|--|--------------|---|--|
| +            | -           | Signal name  | Input/Output |   |  |
| 15<br>(L/W)  | 14<br>(B/R) | VVEL actuator motor<br>(Low lift) (bank 2)                             | Output       | [Engine is running]<br>• Warm-up condition<br>• Idle speed                                  | 0 - 14 V★<br> |
|              |             |  |              | [Engine is running]<br>• Warm-up condition<br>• When revving engine up to 3,000 rpm quickly | 0 - 14 V★<br> |
| 16<br>(G)    | 19<br>(L)   | VVEL control shaft position sensor 2 (bank 1)                          | Input        | [Engine is running]<br>• Warm-up condition<br>• Idle speed                                  | 3.50 - 4.75 V  |
|              |             |  |              | [Engine is running]<br>• Warm-up condition<br>• When revving engine up to 3,000 rpm quickly | 0.25 - 4.75 V  |
| 17<br>(Y)    | —           | Sensor ground<br>[VVEL control shaft position sensor 2 (bank 2)]       | —            | —   | —  |
| 18<br>(R)    | 17<br>(L)   | VVEL control shaft position sensor 2 (bank 2)                          | Input        | [Engine is running]<br>• Warm-up condition<br>• Idle speed                                  | 3.50 - 4.75 V  |
|              |             |  |              | [Engine is running]<br>• Warm-up condition<br>• When revving engine up to 3,000 rpm quickly | 0.25 - 4.75 V  |
| 19<br>(L)    | —           | Sensor ground<br>[VVEL control shaft position sensor 2 (bank 1)]       | —            | —   | —  |
| 20<br>(R)    | 19<br>(L)   | Sensor power supply<br>[VVEL control shaft position sensor 2 (bank 1)] | —            | [Ignition switch: ON]   | 5 V  |
| 21<br>(V)    | 14<br>(B/R) | VVEL actuator motor relay abort signal<br>[ECM]                        | Input        | [Engine is running]<br>• Warm-up condition<br>• Idle speed                                  | 0 V  |
| 22<br>(G)    | 17<br>(Y)   | Sensor power supply<br>[VVEL control shaft position sensor 2 (bank 2)] | —            | [Ignition switch: ON]   | 5 V  |
| 23<br>(P)    | 14<br>(B/R) | VVEL control motor relay   | Output       | [Ignition switch: OFF]  | BATTERY VOLTAGE<br>(11 - 14 V)   |
|              |             |  |              | [Ignition switch: ON]   | 0 - 1.0 V  |
| 24<br>(L)    | —           | ENG communication line   | Input/Output | —   | —  |

A

EC

C

D

E

F

G

H

I

J

K

L

M

N

O

P

# VVEL CONTROL MODULE

< ECU DIAGNOSIS INFORMATION >

[VK56VD FOR MEXICO]

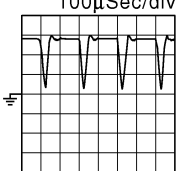
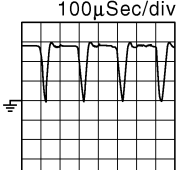
| Terminal No. |             | Description                               |              | Condition  | Value (Approx.)   |
|--------------|-------------|---|--------------|--|---|
| +            | -           | Signal name                               | Input/Output |  |   |
| 25<br>(L/W)  | 14<br>(B/R) | VVEL control motor<br>(Low lift) (bank 1) | Output       | [Engine is running] <ul style="list-style-type: none"> <li>• Warm-up condition</li> <li>• Idle speed</li> </ul>                                  | 0 - 14 V★<br>100μSec/div<br><br>5V/div JMBIA0854ZZ |
|              |             |   |              | [Engine is running] <ul style="list-style-type: none"> <li>• Warm-up condition</li> <li>• When revving engine up to 3,000 rpm quickly</li> </ul> | 0 - 14 V★<br>100μSec/div<br><br>5V/div JMBIA0855ZZ |

★: Average voltage for pulse signal (Actual pulse signal can be confirmed by oscilloscope.)

# WIRING DIAGRAM

## ENGINE CONTROL SYSTEM

### Wiring Diagram

INFOID:000000007758184

A

EC

For connector terminal arrangements, harness layouts, and alphabets in a  (option abbreviation; if not described in wiring diagram), refer to [GI-12. "Connector Information"](#).

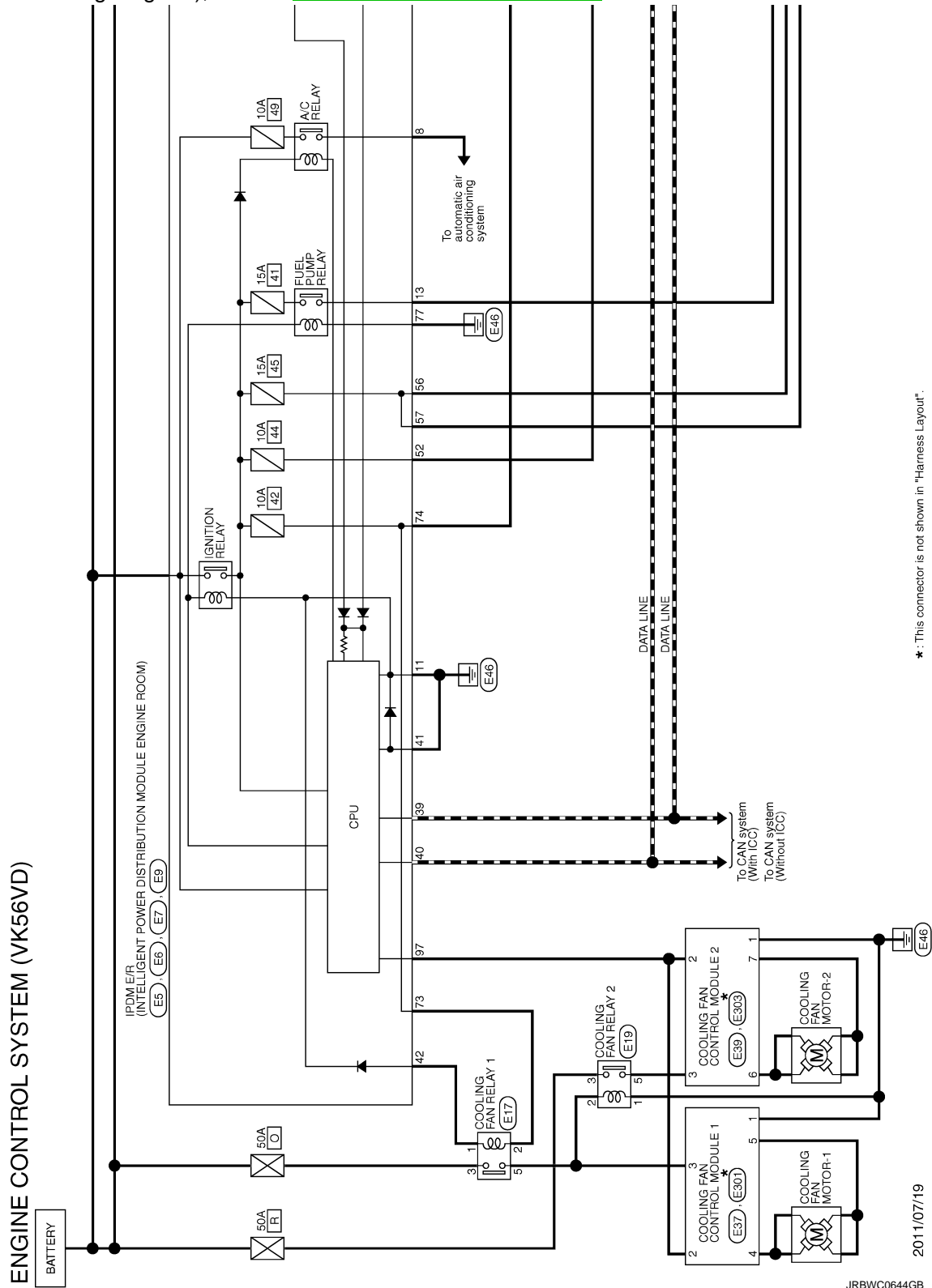

\*: This connector is not shown in "Harness Layout".

2011/07/19

JRBWC0644GB

C

D

E

F

G

H

I

J

K

L

M

N

O

P

# ENGINE CONTROL SYSTEM

< WIRING DIAGRAM >

[VK56VD FOR MEXICO]

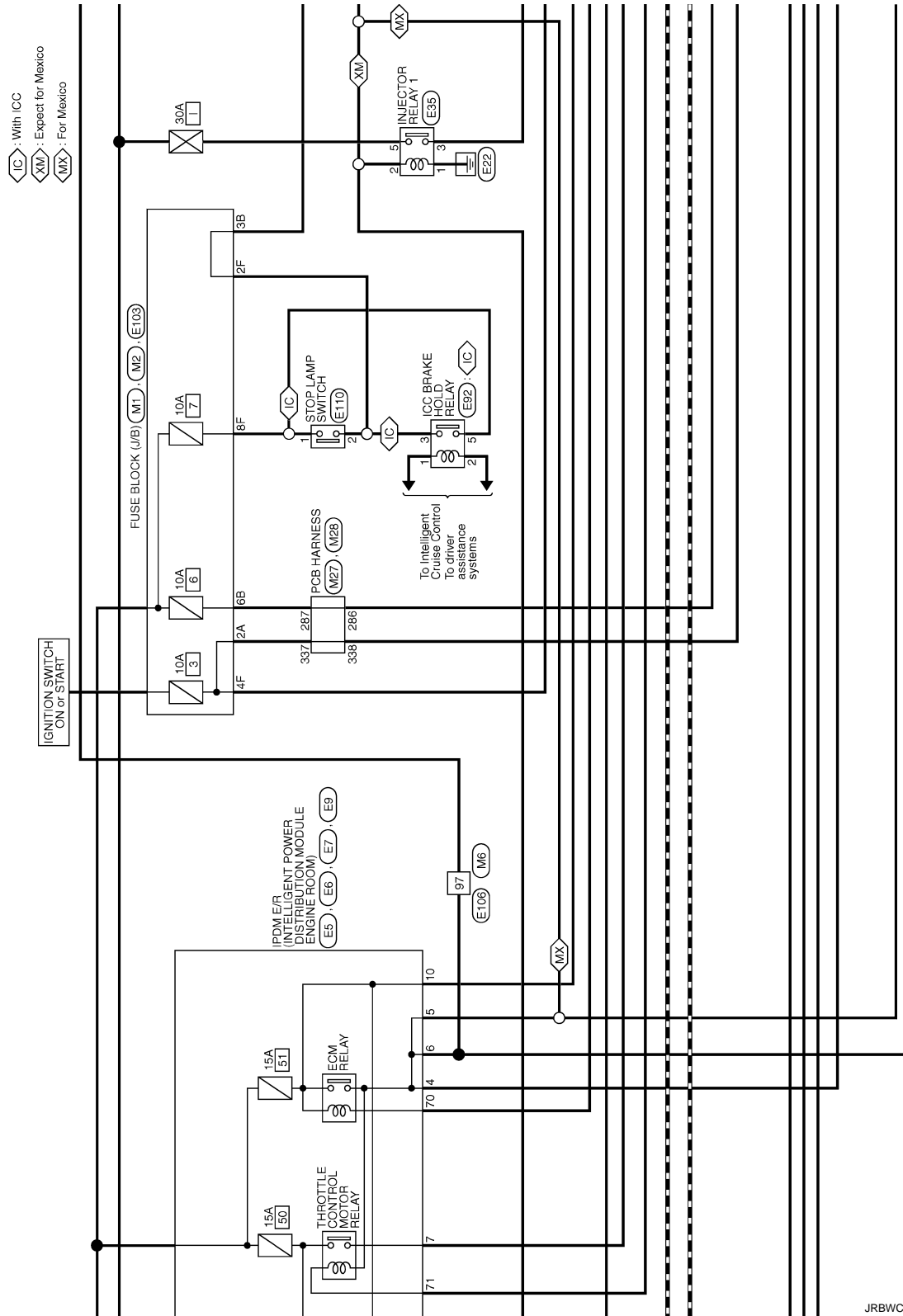

JRBWC0645GB

# ENGINE CONTROL SYSTEM

< WIRING DIAGRAM >

[VK56VD FOR MEXICO]

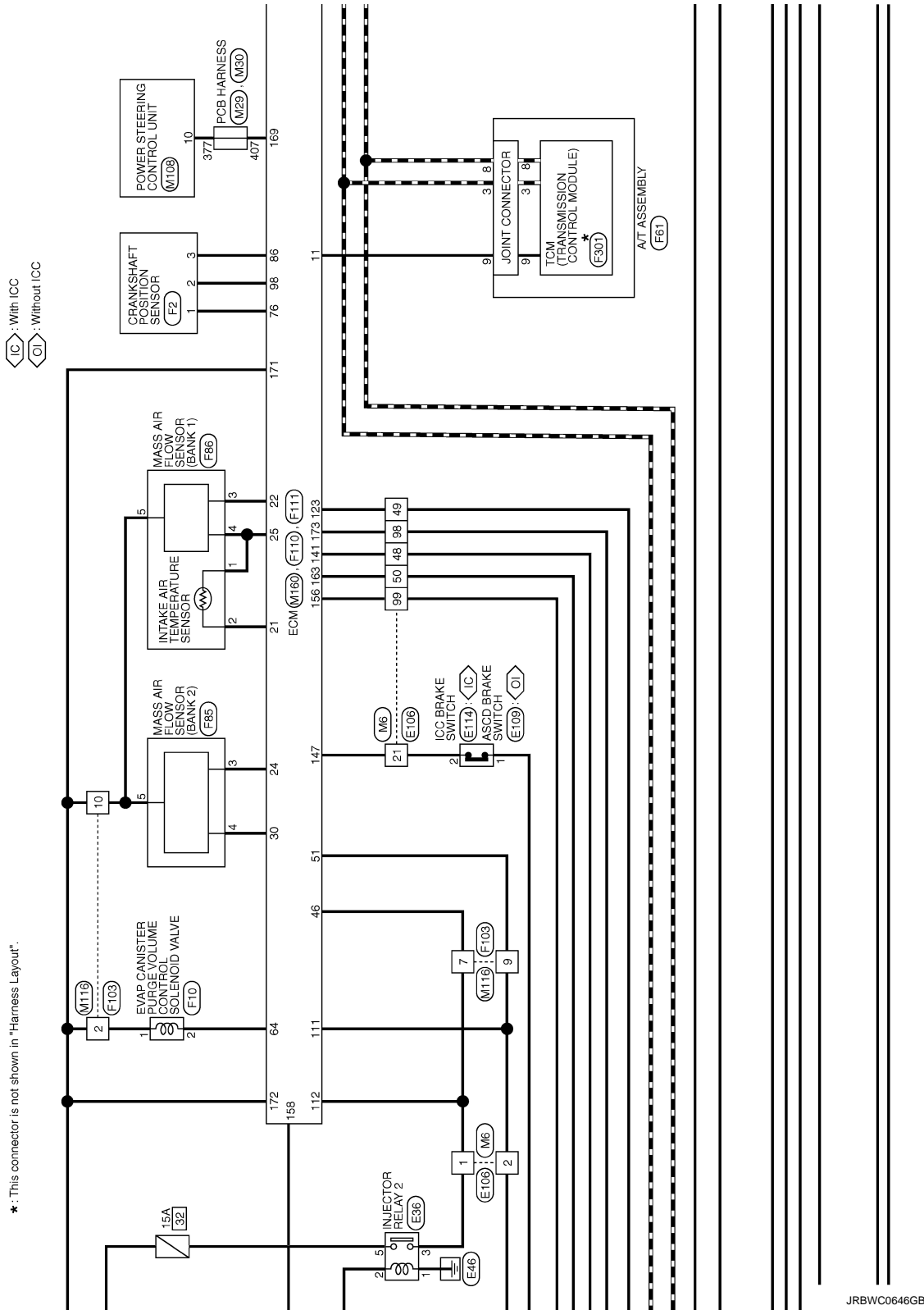

A  
**EC**  
 C  
 D  
 E  
 F  
 G  
 H  
 I  
 J  
 K  
 L  
 M  
 N  
 O  
 P

JRBWC0646GB

# ENGINE CONTROL SYSTEM

< WIRING DIAGRAM >

[VK56VD FOR MEXICO]

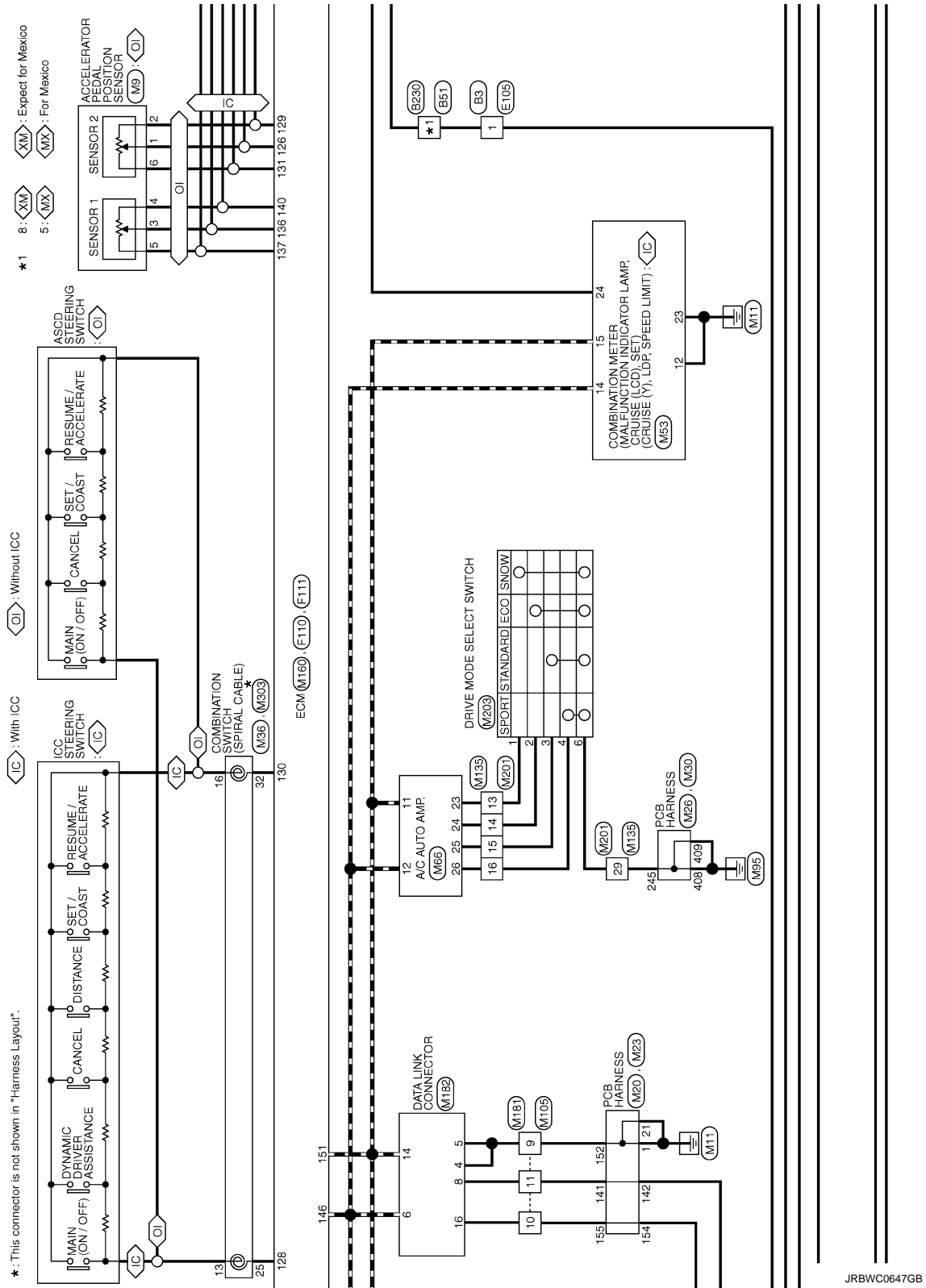

JRBWC0647GB

# ENGINE CONTROL SYSTEM

< WIRING DIAGRAM >

[VK56VD FOR MEXICO]

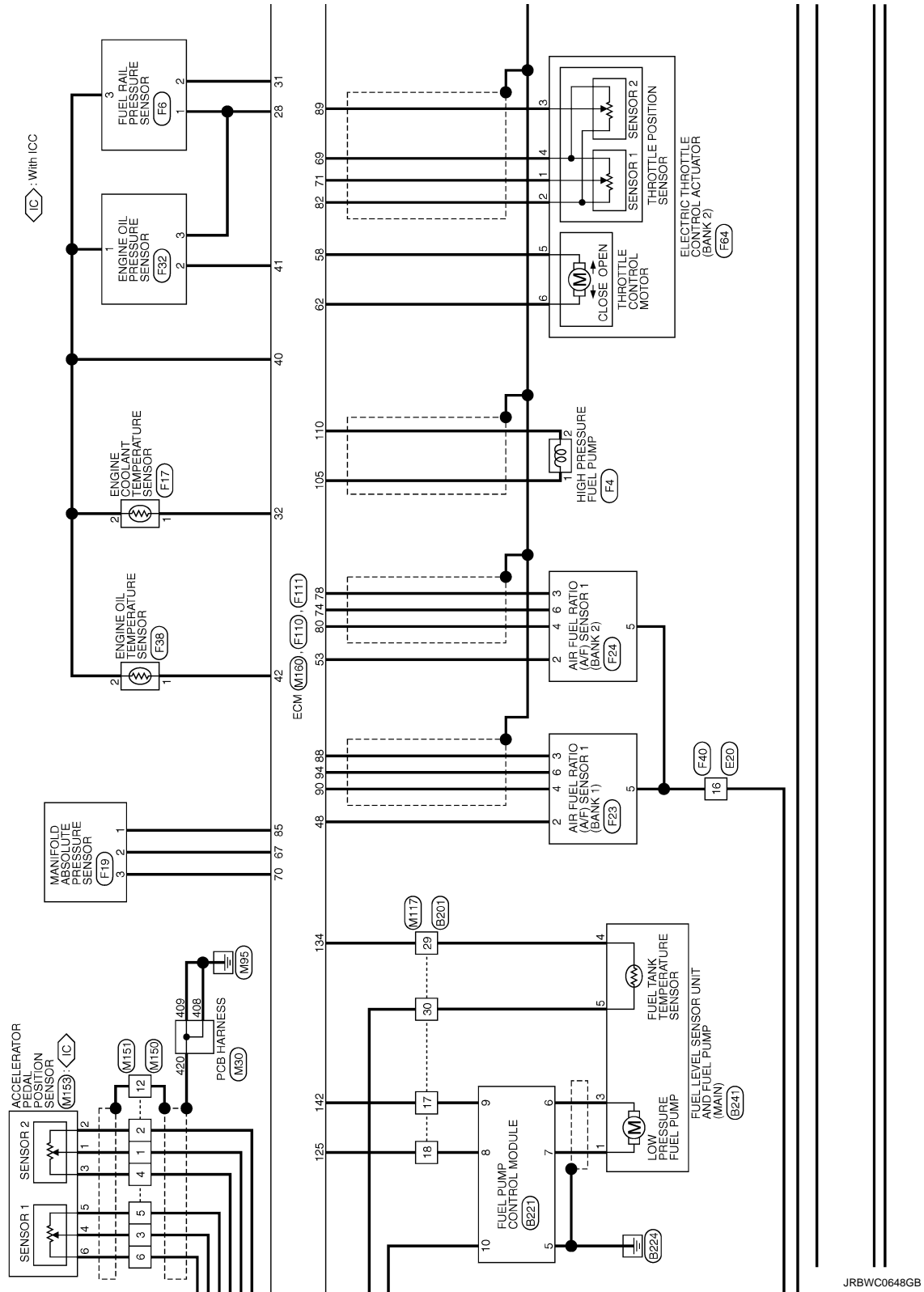

JRBWC0648GB

A  
EC  
C  
D  
E  
F  
G  
H  
I  
J  
K  
L  
M  
N  
O  
P

# ENGINE CONTROL SYSTEM

< WIRING DIAGRAM >

[VK56VD FOR MEXICO]

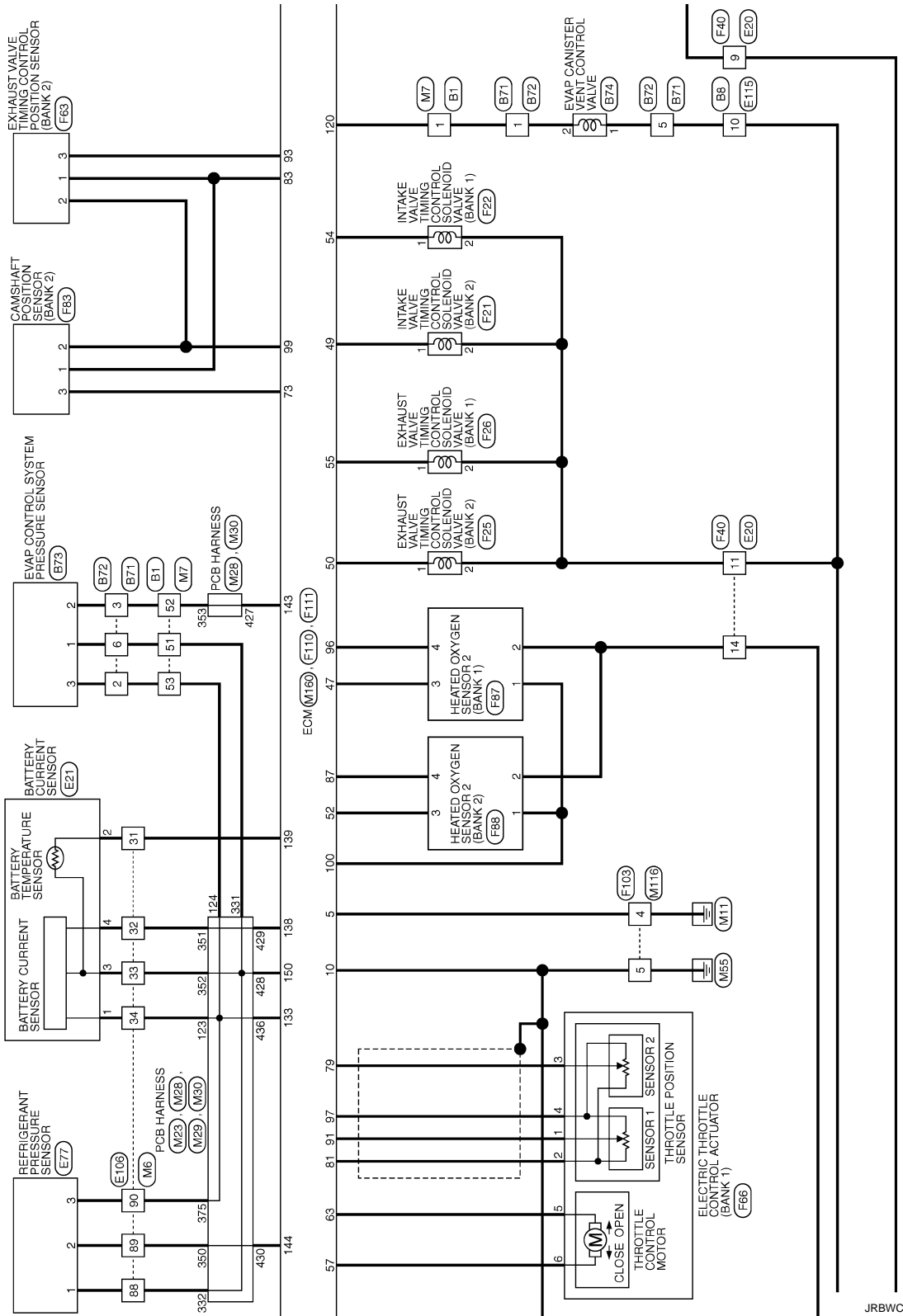

JRBWC0649GB



# ENGINE CONTROL SYSTEM

< WIRING DIAGRAM >

[VK56VD FOR MEXICO]

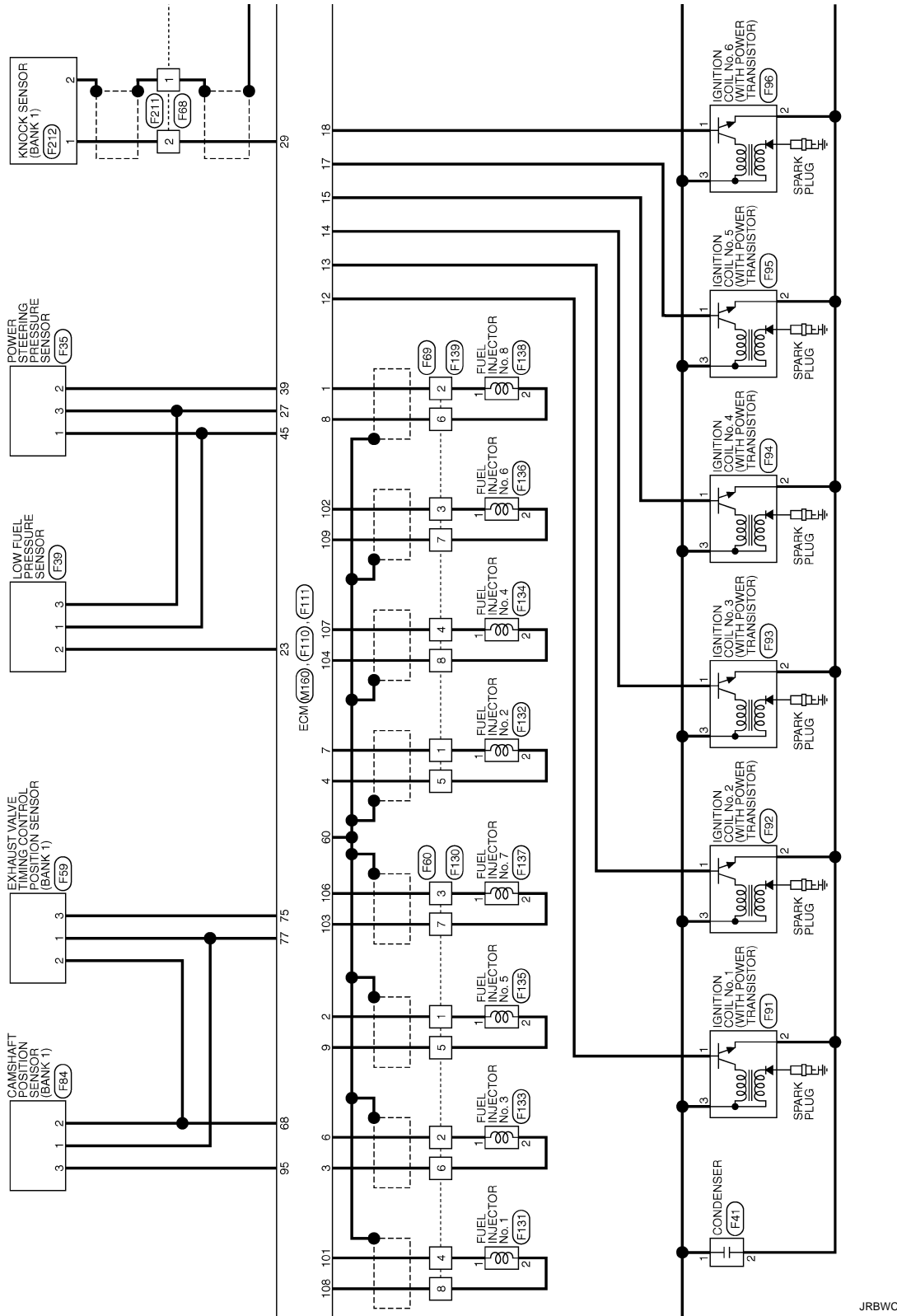

JRBWC0650GB

A  
EC  
C  
D  
E  
F  
G  
H  
I  
J  
K  
L  
M  
N  
O  
P

# ENGINE CONTROL SYSTEM

< WIRING DIAGRAM >

[VK56VD FOR MEXICO]

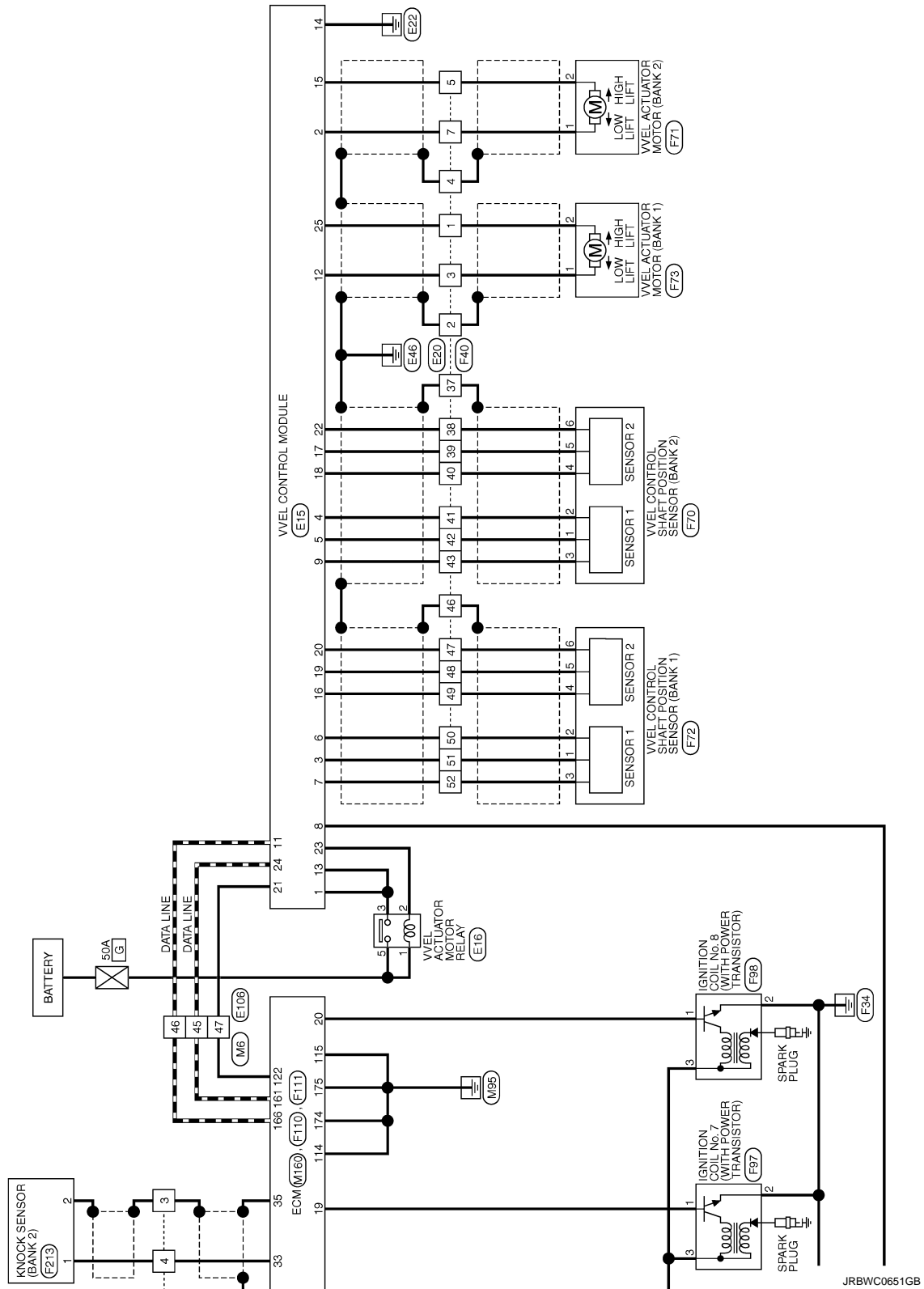

JRBWC0651GB

# DIAGNOSIS AND REPAIR WORKFLOW

< BASIC INSPECTION >

[VK56VD FOR MEXICO]

## BASIC INSPECTION

### DIAGNOSIS AND REPAIR WORKFLOW

Work Flow

INFOID:000000007758185

OVERALL SEQUENCE

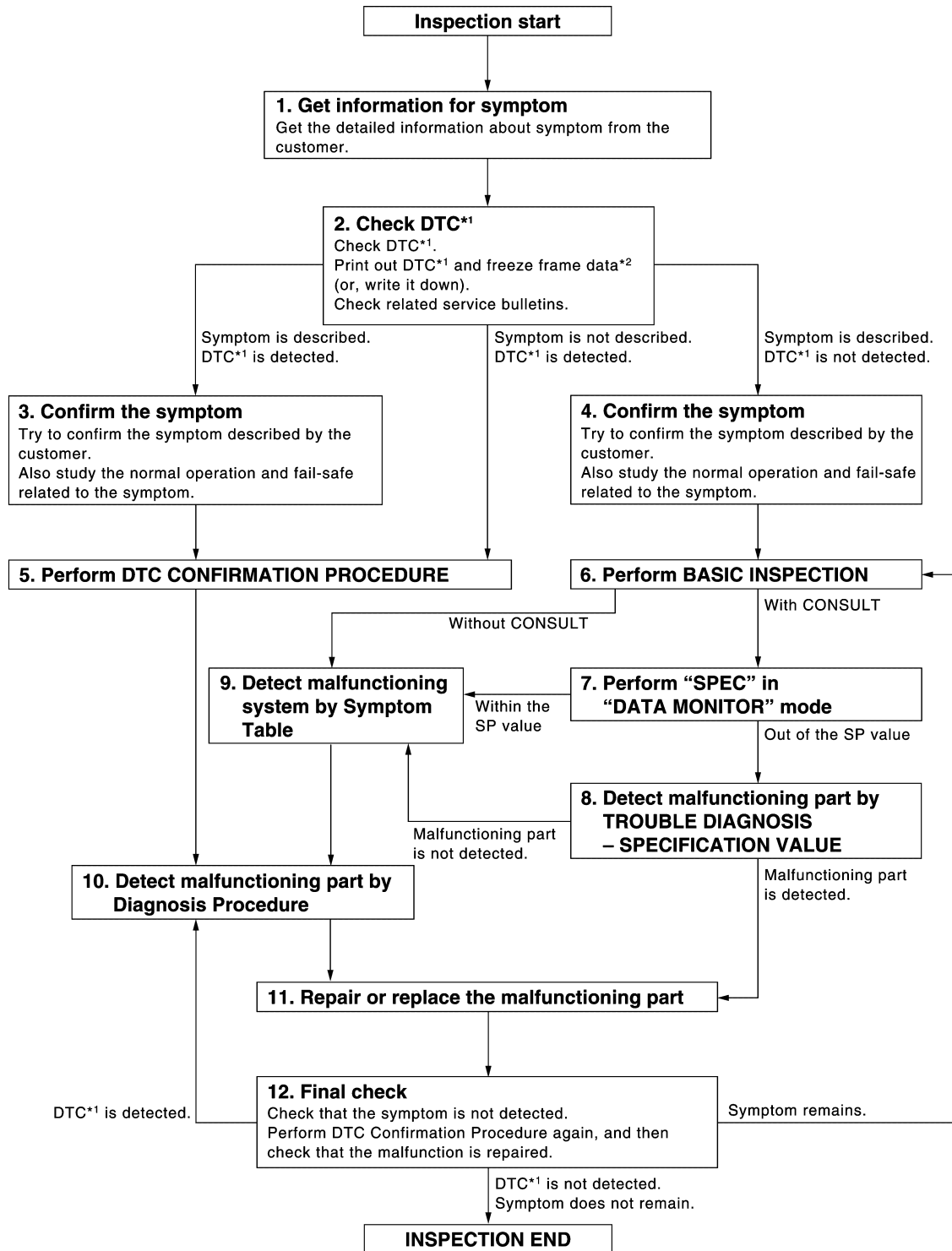

\*1: Include 1st trip DTC.

\*2: Include 1st trip freeze frame data.

JSBIA1228GB

DETAILED FLOW

# DIAGNOSIS AND REPAIR WORKFLOW

< BASIC INSPECTION >

[VK56VD FOR MEXICO]

## 1.GET INFORMATION FOR SYMPTOM

---

Get the detailed information from the customer about the symptom (the condition and the environment when the incident/malfunction occurred) using the "Diagnostic Work Sheet". (Refer to [EC-1677, "Diagnostic Work Sheet"](#).)

>> GO TO 2.

## 2.CHECK DTC

---

1. Check DTC.
2. Perform the following procedure if DTC is displayed.
  - Record DTC and freeze frame data. (Print them out with CONSULT or GST.)
  - Erase DTC.
  - Study the relationship between the cause detected by DTC and the symptom described by the customer. (Symptom Matrix Chart is useful. Refer to [EC-2003, "Symptom Table"](#).)
3. Check related service bulletins for information.

Are any symptoms described and any DTCs detected?

Symptom is described, DTC is detected>>GO TO 3.

Symptom is described, DTC is not detected>>GO TO 4.

Symptom is not described, DTC is detected>>GO TO 5.

## 3.CONFIRM THE SYMPTOM

---

Try to confirm the symptom described by the customer (except MIL ON).

Also study the normal operation and fail-safe related to the symptom. Refer to [EC-2008, "Description"](#) and [EC-1647, "Fail-safe"](#).

Diagnosis Work Sheet is useful to verify the incident.

Verify relation between the symptom and the condition when the symptom is detected.

>> GO TO 5.

## 4.CONFIRM THE SYMPTOM

---

Try to confirm the symptom described by the customer.

Also study the normal operation and fail-safe related to the symptom. Refer to [EC-2003, "Symptom Table"](#) and [EC-1647, "Fail-safe"](#).

Diagnosis Work Sheet is useful to verify the incident.

Verify relation between the symptom and the condition when the symptom is detected.

>> GO TO 6.

## 5.PERFORM DTC CONFIRMATION PROCEDURE

---

Perform DTC CONFIRMATION PROCEDURE for the displayed DTC, and then check that DTC is detected again.

If two or more DTCs are detected, refer to [EC-1649, "DTC Inspection Priority Chart"](#) and determine trouble diagnosis order.

### NOTE:

- Freeze frame data is useful if the DTC is not detected.
- Perform Component Function Check if DTC CONFIRMATION PROCEDURE is not included on Service Manual. This simplified check procedure is an effective alternative though DTC cannot be detected during this check.
  - If the result of Component Function Check is NG, it is the same as the detection of DTC by DTC CONFIRMATION PROCEDURE.

Is DTC detected?

YES >> GO TO 10.

NO >> Check according to [GI-44, "Intermittent Incident"](#).

## 6.PERFORM BASIC INSPECTION

---

Perform [EC-1679, "Work Procedure"](#).

Will CONSULT be used?

# DIAGNOSIS AND REPAIR WORKFLOW

< BASIC INSPECTION >

[VK56VD FOR MEXICO]

- YES >> GO TO 7.
- NO >> GO TO 9.

## 7. PERFORM SPEC IN DATA MONITOR MODE

With CONSULT

Check that "MAS A/F SE-B1", "MAS A/F SE-B2", "B/FUEL SCHDL", "A/F ALPHA-B1" and "A/F ALPHA-B2" are within the SP value using "SPEC" in "DATA MONITOR" mode with CONSULT. Refer to [EC-1700. "Component Function Check"](#).

Is the measurement value within the SP value?

- YES >> GO TO 9.
- NO >> GO TO 8.

## 8. DETECT MALFUNCTIONING PART BY TROUBLE DIAGNOSIS - SPECIFICATION VALUE

Detect malfunctioning part according to [EC-1701. "Diagnosis Procedure"](#).

Is a malfunctioning part detected?

- YES >> GO TO 11.
- NO >> GO TO 9.

## 9. DETECT MALFUNCTIONING SYSTEM BY SYMPTOM TABLE

Detect malfunctioning system according to [EC-2003. "Symptom Table"](#) based on the confirmed symptom in step 4, and determine the trouble diagnosis order based on possible causes and symptoms.

>> GO TO 10.

## 10. DETECT MALFUNCTIONING PART BY DIAGNOSIS PROCEDURE

Inspect according to Diagnosis Procedure of the system.

### NOTE:

The Diagnosis Procedure in EC section described based on open circuit inspection. A short circuit inspection is also required for the circuit check in the Diagnosis Procedure. For details, refer to [GI-47. "Circuit Inspection"](#).

Is a malfunctioning part detected?

- YES >> GO TO 11.
- NO >> Monitor input data from related sensors or check voltage of related ECM terminals using CONSULT. Refer to [EC-1624. "Reference Value"](#).

## 11. REPAIR OR REPLACE THE MALFUNCTIONING PART

1. Repair or replace the malfunctioning part.
2. Reconnect parts or connectors disconnected during Diagnosis Procedure again after repair and replacement.
3. Check DTC. If DTC is displayed, erase it.

>> GO TO 12.

## 12. FINAL CHECK

When DTC was detected in step 2, perform DTC CONFIRMATION PROCEDURE or Component Function Check again, and then check that the malfunction have been completely repaired.

When symptom was described from the customer, refer to confirmed symptom in step 3 or 4, and check that the symptom is not detected.

Is DTC detected and does symptom remain?

- YES-1 >> DTC is detected: GO TO 10.
- YES-2 >> Symptom remains: GO TO 6.
- NO >> Before returning the vehicle to the customer, always erase unnecessary DTC in ECM and TCM (Transmission Control Module). If the completion of SRT is needed, drive vehicle under the specific driving pattern. Refer to [EC-1695. "Description"](#).

## Diagnostic Work Sheet

INFOID:000000007758186

### DESCRIPTION



**BASIC INSPECTION**

**Work Procedure**

INFOID:000000007758187

**1.INSPECTION START**

1. Check service records for any recent repairs that may indicate a related malfunction, or a current need for scheduled maintenance.
2. Open engine hood and check the following:
  - Harness connectors for improper connections
  - Wiring harness for improper connections, pinches and cut
  - Vacuum hoses for splits, kinks and improper connections
  - Hoses and ducts for leakage
  - Air cleaner clogging
  - Gasket
3. Check that electrical or mechanical loads are not applied.
  - Headlamp switch is OFF.
  - Air conditioner switch is OFF.
  - Rear window defogger switch is OFF.
  - Steering wheel is in the straight-ahead position, etc.
4. Start engine and warm it up until engine coolant temperature indicator points to the middle of gauge. Check that engine stays below 1,000 rpm.

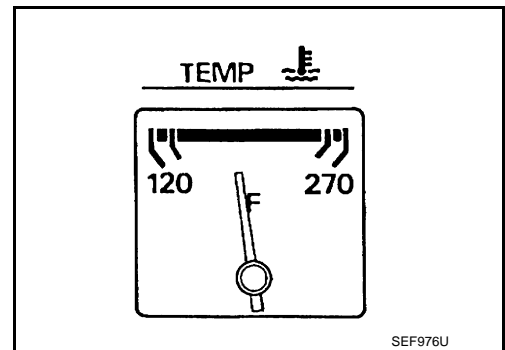
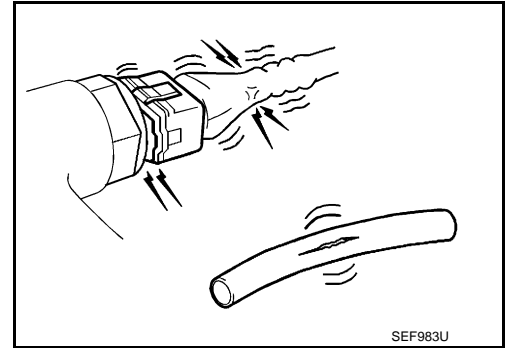

5. Run engine at approximately 2,000 rpm for approximately 2 minutes under no load.
6. Check that no DTC is displayed with CONSULT or GST.

Are any DTCs detected?

- YES >> GO TO 2.
- NO >> GO TO 3.

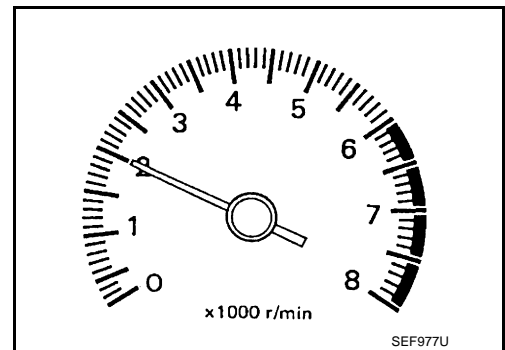

**2.REPAIR OR REPLACE**

Repair or replace components as necessary according to corresponding Diagnosis Procedure.

>> GO TO 3

**3.CHECK IDLE SPEED**

1. Run engine at approximately 2,000 rpm for approximately 2 minutes under no load.

A  
EC  
C  
D  
E  
F  
G  
H  
I  
J  
K  
L  
M  
N  
O  
P

# BASIC INSPECTION

[VK56VD FOR MEXICO]

## < BASIC INSPECTION >

- Rev engine between 2,000 and 3,000 rpm 2 or 3 times under no load, then run engine at idle speed for approximately 1 minute.
- Check idle speed.  
For procedure, refer to [EC-2009, "Inspection"](#).  
For specification, refer to [EC-2016, "Idle Speed"](#).

Is the inspection result normal?

- YES >> GO TO 10.  
NO >> GO TO 4.

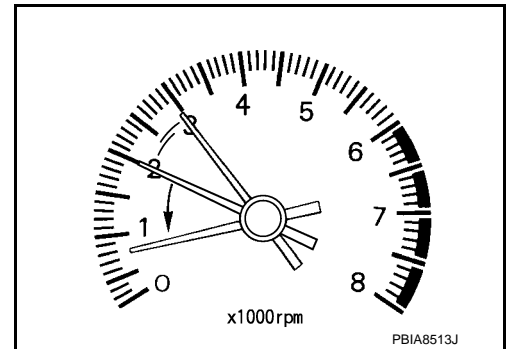

## 4.PERFORM ACCELERATOR PEDAL RELEASED POSITION LEARNING

- Stop engine.
- Perform [EC-1685, "Work Procedure"](#).

>> GO TO 5.

## 5.PERFORM THROTTLE VALVE CLOSED POSITION LEARNING

Perform [EC-1686, "Work Procedure"](#).

>> GO TO 6.

## 6.PERFORM IDLE AIR VOLUME LEARNING

Perform [EC-1687, "Work Procedure"](#).

Is Idle Air Volume Learning carried out successfully?

- YES >> GO TO 7.  
NO >> Follow the instruction of Idle Air Volume Learning. Then GO TO 4.

## 7.CHECK IDLE SPEED AGAIN

- Start engine and warm it up to normal operating temperature.
- Check idle speed.  
For procedure, refer to [EC-2009, "Inspection"](#).  
For specification, refer to [EC-2016, "Idle Speed"](#).

Is the inspection result normal?

- YES >> GO TO 10.  
NO >> GO TO 8.

## 8.DETECT MALFUNCTIONING PART

Check the Following.

- Check camshaft position sensor and circuit. Refer to [EC-1828, "DTC Logic"](#).
- Check crankshaft position sensor and circuit. Refer to [EC-1824, "DTC Logic"](#).

Is the inspection result normal?

- YES >> GO TO 9.  
NO >> Repair or replace malfunctioning part. Then GO TO 4.

## 9.CHECK ECM FUNCTION

- Substitute with a non-malfunctioning ECM to check ECM function. (ECM may be the cause of the incident, although this is rare.)
- Perform initialization of IVIS (NATS) system and registration of all IVIS (NATS) ignition key IDs. Refer to [SEC-39, "ECM : Work Procedure"](#).

>> GO TO 4.

## 10.CHECK IGNITION TIMING

- Run engine at idle.
- Check ignition timing with a timing light.  
For procedure, refer to [EC-2010, "Inspection"](#).



# BASIC INSPECTION

[VK56VD FOR MEXICO]

< BASIC INSPECTION >

For specification, refer to [EC-2016, "Ignition Timing"](#).

Is the inspection result normal?

- YES >> GO TO 19.  
NO >> GO TO 11.

## 11.PERFORM ACCELERATOR PEDAL RELEASED POSITION LEARNING

1. Stop engine.
2. Perform [EC-1685, "Work Procedure"](#).

>> GO TO 12.

## 12.PERFORM THROTTLE VALVE CLOSED POSITION LEARNING

Perform [EC-1686, "Work Procedure"](#).

>> GO TO 13.

## 13.PERFORM IDLE AIR VOLUME LEARNING

Perform [EC-1687, "Work Procedure"](#).

Is Idle Air Volume Learning carried out successfully?

- YES >> GO TO 14.  
NO >> Follow the instruction of Idle Air Volume Learning. Then GO TO 4.

## 14.CHECK IDLE SPEED AGAIN

1. Start engine and warm it up to normal operating temperature.
2. Check idle speed.  
For procedure, refer to [EC-2009, "Inspection"](#).  
For specification, refer to [EC-2016, "Idle Speed"](#).

Is the inspection result normal?

- YES >> GO TO 15.  
NO >> GO TO 17.

## 15.CHECK IGNITION TIMING AGAIN

1. Run engine at idle.
2. Check ignition timing with a timing light.  
For procedure, refer to [EC-2010, "Inspection"](#).  
For specification, refer to [EC-2016, "Ignition Timing"](#).

Is the inspection result normal?

- YES >> GO TO 19.  
NO >> GO TO 16.

## 16.CHECK TIMING CHAIN INSTALLATION

Check timing chain installation. Refer to [EM-244, "Inspection"](#).

Is the inspection result normal?

- YES >> GO TO 17.  
NO >> Repair the timing chain installation. Then GO TO 4.

## 17.DETECT MALFUNCTIONING PART

Check the following.

- Check camshaft position sensor and circuit. Refer to [EC-1828, "DTC Logic"](#).
- Check crankshaft position sensor and circuit. Refer to [EC-1824, "DTC Logic"](#).

Is the inspection result normal?

- YES >> GO TO 18.  
NO >> Repair or replace malfunctioning part. Then GO TO 4.

## 18.CHECK ECM FUNCTION

1. Substitute with a non-malfunctioning ECM to check ECM function. (ECM may be the cause of the incident, although this is rare.)

A

EC

C

D

E

F

G

H

I

J

K

L

M

N

O

P

## BASIC INSPECTION

< BASIC INSPECTION >

[VK56VD FOR MEXICO]

---

2. Perform initialization of IVIS (NATS) system and registration of all IVIS (NATS) ignition key IDs. Refer to .

>> GO TO 4.

**19.**INSPECTION END

---

If ECM is replaced during this BASIC INSPECTION procedure, perform [EC-1683, "Work Procedure"](#).

>> INSPECTION END

# ADDITIONAL SERVICE WHEN REPLACING ECM

< BASIC INSPECTION >

[VK56VD FOR MEXICO]

## ADDITIONAL SERVICE WHEN REPLACING ECM

### Description

INFOID:000000007758188

When replacing ECM, the following procedure must be performed.

### Work Procedure

INFOID:000000007758189

**1.**PERFORM INITIALIZATION OF IVIS (NATS) SYSTEM AND REGISTRATION OF ALL IVIS (NATS) IGNITION KEY IDS

Perform initialization of IVIS (NATS) system and registration of all IVIS (NATS) ignition key IDs. Refer to [SEC-39, "ECM : Work Procedure"](#).

>> GO TO 2.

**2.**PERFORM ACCELERATOR PEDAL RELEASED POSITION LEARNING

Perform accelerator pedal released position learning. Refer to [EC-1685, "Work Procedure"](#).

>> GO TO 3.

**3.**PERFORM THROTTLE VALVE CLOSED POSITION LEARNING

Perform throttle valve closed position learning. Refer to [EC-1686, "Work Procedure"](#).

>> GO TO 4.

**4.**PERFORM IDLE AIR VOLUME LEARNING

Perform idle air volume learning. Refer to [EC-1687, "Work Procedure"](#).

>> WORK END

A  
EC  
C  
D  
E  
F  
G  
H  
I  
J  
K  
L  
M  
N  
O  
P

## ADDITIONAL SERVICE WHEN REPLACING VVEL CONTROL MODULE

< BASIC INSPECTION >

[VK56VD FOR MEXICO]

---

## ADDITIONAL SERVICE WHEN REPLACING VVEL CONTROL MODULE

### Description

INFOID:000000007758190

When replacing VVEL control module, the following procedure must be performed.

### Work Procedure

INFOID:000000007758191

#### 1. PERFORM IDLE AIR VOLUME LEARNING

---

Perform idle air volume learning. Refer to [EC-1687, "Work Procedure"](#).

>> WORK END

# ACCELERATOR PEDAL RELEASED POSITION LEARNING

< BASIC INSPECTION >

[VK56VD FOR MEXICO]

## ACCELERATOR PEDAL RELEASED POSITION LEARNING

### Description

INFOID:000000007758194

Accelerator Pedal Released Position Learning is a function of ECM to learn the fully released position of the accelerator pedal by monitoring the accelerator pedal position sensor output signal. It must be performed each time the harness connector of the accelerator pedal position sensor or ECM is disconnected.

### Work Procedure

INFOID:000000007758195

#### 1. START

1. Check that accelerator pedal is fully released.
2. Turn ignition switch ON and wait at least 2 seconds.
3. Turn ignition switch OFF and wait at least 10 seconds.
4. Turn ignition switch ON and wait at least 2 seconds.
5. Turn ignition switch OFF and wait at least 10 seconds.

>> END

A

EC

C

D

E

F

G

H

I

J

K

L

M

N

O

P

# THROTTLE VALVE CLOSED POSITION LEARNING

< BASIC INSPECTION >

[VK56VD FOR MEXICO]

## THROTTLE VALVE CLOSED POSITION LEARNING

### Description

INFOID:000000007785153

Throttle Valve Closed Position Learning is a function of ECM to learn the fully closed position of the throttle valve by monitoring the throttle position sensor output signal. It must be performed each time the harness connector of the electric throttle control actuator or ECM is disconnected or electric throttle control actuator inside is cleaned.

### Work Procedure

INFOID:000000007785154

#### 1. START

##### ④ With CONSULT

1. Turn ignition switch ON.
2. Select "CLSD THL POS LEARN" in "WORK SUPPORT" mode.
3. Follow the instructions on the CONSULT display.
4. Turn ignition switch OFF and wait at least 10 seconds.  
Check that throttle valve moves during the above 10 seconds by confirming the operating sound.

##### ⊗ Without CONSULT

1. Start the engine.  
**NOTE:**  
Engine coolant temperature is 25°C (77°F) or less before engine starts.
2. Warm up the engine.  
**NOTE:**  
Raise engine coolant temperature until it reaches 65°C (149°F) or more.
3. Turn ignition switch OFF and wait at least 10 seconds.  
Check that throttle valve moves during the above 10 seconds by confirming the operating sound.

>> END

## IDLE AIR VOLUME LEARNING

### Description

INFOID:000000007758198

Idle Air Volume Learning is a function of ECM to learn the idle air volume that keeps engine idle speed within the specific range. It must be performed under the following conditions:

- Each time the electric throttle control actuator or ECM is replaced.
- Idle speed or ignition timing is out of the specification.

### Work Procedure

INFOID:000000007758199

#### 1. PRECONDITIONING

Check that all of the following conditions are satisfied.

Learning will be cancelled if any of the following conditions are missed for even a moment.

- Battery voltage: More than 12.9 V (At idle)
- Engine coolant temperature: 70 - 105°C (158 - 221°F)
- Selector lever position: P or N
- Electric load switch: OFF  
(Air conditioner, headlamp, rear window defogger)

**On vehicles equipped with daytime light systems, if the parking brake is applied before the engine is started the headlamp will not illuminate.**

- Steering wheel: Neutral (Straight-ahead position)
- Vehicle speed: Stopped
- Transmission: Warmed-up

- With CONSULT: Drive vehicle until "ATF TEMP 2" in "DATA MONITOR" mode of "A/T" system indicates less than 0.9 V.

- Without CONSULT: Drive vehicle for 10 minutes.

Will CONSULT be used?

YES >> GO TO 2.

NO >> GO TO 3.

#### 2. PERFORM IDLE AIR VOLUME LEARNING

With CONSULT

1. Perform Accelerator Pedal Released Position Learning. Refer to [EC-1685, "Work Procedure"](#).
2. Perform Throttle Valve Closed Position Learning. [EC-1686, "Work Procedure"](#).
3. Start engine and warm it up to normal operating temperature.
4. Select "IDLE AIR VOL LEARN" in "WORK SUPPORT" mode.
5. Touch "START" and wait 20 seconds.

Is "CMPLT" displayed on CONSULT screen?

YES >> GO TO 4.

NO >> GO TO 5.

#### 3. PERFORM IDLE AIR VOLUME LEARNING

Without CONSULT

**NOTE:**

- **It is better to count the time accurately with a clock.**
- **It is impossible to switch the diagnostic mode when an accelerator pedal position sensor circuit has a malfunction.**

1. Perform Accelerator Pedal Released Position Learning. Refer to [EC-1685, "Work Procedure"](#).
2. Perform Throttle Valve Closed Position Learning. [EC-1686, "Work Procedure"](#).
3. Start engine and warm it up to normal operating temperature.
4. Turn ignition switch OFF and wait at least 10 seconds.
5. Confirm that accelerator pedal is fully released, turn ignition switch ON and wait 3 seconds.
6. Repeat the following procedure quickly 5 times within 5 seconds.
  - Fully depress the accelerator pedal.
  - Fully release the accelerator pedal.
7. Wait 7 seconds, fully depress the accelerator pedal for approx. 20 seconds until the MIL stops blinking and turns ON.
8. Fully release the accelerator pedal within 3 seconds after the MIL turns ON.

# IDLE AIR VOLUME LEARNING

< BASIC INSPECTION >

[VK56VD FOR MEXICO]

9. Start engine and let it idle.
10. Wait 20 seconds.

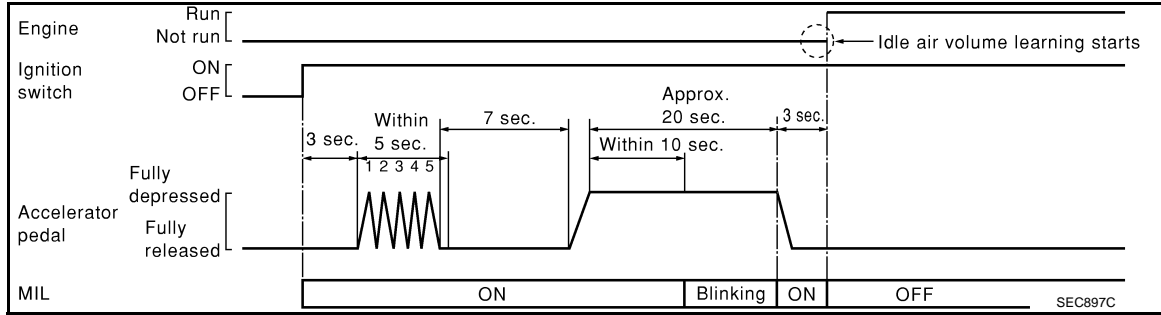

>> GO TO 4.

## 4. CHECK IDLE SPEED AND IGNITION TIMING

Rev up engine two or three times and check that idle speed and ignition timing are within the specifications. For procedure, refer to [EC-2016. "Idle Speed"](#) and [EC-2016. "Ignition Timing"](#). For specifications, refer to [EC-2016. "Idle Speed"](#) and [EC-2016. "Ignition Timing"](#).

Is the inspection result normal?

- YES >> INSPECTION END
- NO >> GO TO 5.

## 5. DETECT MALFUNCTIONING PART-I

Check the following

- Check that throttle valve is fully closed.
- Check PCV valve operation.
- Check that downstream of throttle valve is free from air leakage.

Is the inspection result normal?

- YES >> GO TO 6.
- NO >> Repair or replace malfunctioning part.

## 6. DETECT MALFUNCTIONING PART-II

Engine component parts and their installation condition are questionable. Check and eliminate the cause of the incident.

It is useful to perform "TROUBLE DIAGNOSIS - SPECIFICATION VALUE". Refer to [EC-1700. "Description"](#). If any of the following conditions occur after the engine has started, eliminate the cause of the incident and perform Idle Air Volume Learning again:

- Engine stalls.
- Incorrect idle.

>> INSPECTION END



# VVEL CONTROL SHAFT POSITION SENSOR ADJUSTMENT

< BASIC INSPECTION >

[VK56VD FOR MEXICO]

## VVEL CONTROL SHAFT POSITION SENSOR ADJUSTMENT

### Description

INFOID:000000007758200

VVEL control shaft position sensor adjustment is an operation to adjust the initial position of the VVEL control shaft position sensor.

It must be performed each time VVEL actuator sub assembly is replaced.

#### CAUTION:

- It must be performed only on the replaced bank side.
- It must not be performed except when VVEL actuator sub assembly is replaced. If by any chance the adjustment is performed, replace VVEL actuator sub assembly.

### Work Procedure

INFOID:000000007758201

#### 1. START

Will CONSULT be used?

Will CONSULT be used?

YES >> GO TO 2.

NO >> GO TO 3.

#### 2. PERFORM VVEL CONTROL SHAFT POSITION SENSOR ADJUSTMENT

##### ☑ With CONSULT

1. Turn ignition switch ON.
2. Select "VVEL POS SEN ADJ PREP" in "WORK SUPPORT" mode with CONSULT.
3. Touch "Start" and wait a few seconds.
4. Check that "CMPLT" is displayed on CONSULT screen.
5. Select "VVEL POSITION SEN-B1" or "VVEL POSITION SEN-B2" in "DATA MONITOR" mode with CONSULT.
6. Loosen the VVEL control shaft position sensor mounting bolts (1).
7. Turn the VVEL control shaft position sensor (2) clockwise and counterclockwise while monitoring the output voltage of "VVEL POSITION SEN-B1" or "VVEL POSITION SEN-B2" and adjust the output voltage to be within the standard value.

**Voltage: 500 ± 48 mV**

8. Tighten the VVEL control shaft position sensor mounting bolts.

**Torque: 7.0 N•m (0.71 kg-m, 62 in-lb)**

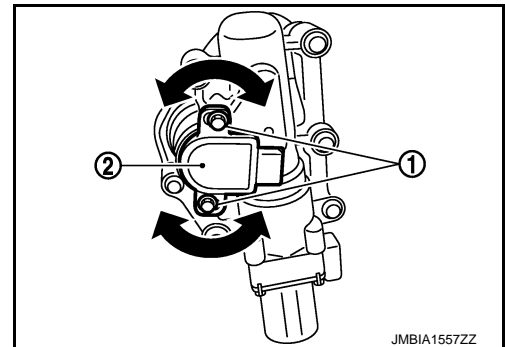

9. Reconfirm that the output voltage of "VVEL POSITION SEN-B1" or "VVEL POSITION SEN-B2" is within the standard value.

**Voltage: 500 ± 48 mV**

#### NOTE:

If it varies from the standard value after the mounting bolts are tightened, perform steps 6 to 8 again.

10. Turn ignition switch OFF and wait at least 10 seconds.
11. Start engine and warm it up to normal operating temperature.
12. Turn ignition switch OFF and wait at least 10 seconds.
13. Perform idle air volume learning. Refer to [EC-1687, "Work Procedure"](#).

>> INSPECTION END

#### 3. PERFORM VVEL CONTROL SHAFT POSITION SENSOR ADJUSTMENT

##### ☒ Without CONSULT

1. Disconnect VVEL control shaft position sensor harness connector.
2. Remove VVEL actuator motor relay.
3. Turn ignition switch ON, wait at least 5 seconds and then turn it OFF.

# VVEL CONTROL SHAFT POSITION SENSOR ADJUSTMENT

< BASIC INSPECTION >

[VK56VD FOR MEXICO]

4. Reconnect all harness connectors disconnected.
5. Install VVEL actuator motor relay.
6. Turn ignition switch ON and wait at least 5 seconds.
7. Loosen the VVEL control shaft position sensor mounting bolts (1).
8. Turn the VVEL control shaft position sensor (2) clockwise and counterclockwise while monitoring the output voltage between the VVEL control module terminals with a tester and adjust the output voltage to be within the standard value.

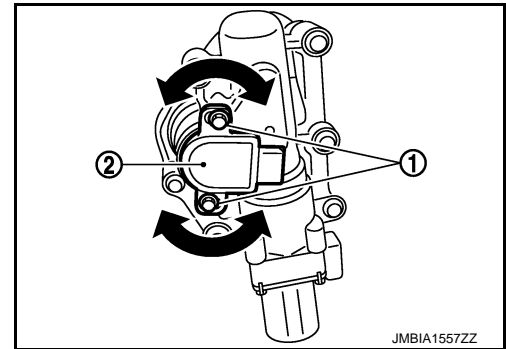

| VVEL control module |           |          |          | Voltage     |
|---------------------|-----------|----------|----------|-------------|
| Bank                | Connector | +        | -        |             |
|                     |           | Terminal | Terminal |             |
| 1                   | E15       | 3        | 6        | 500 ± 48 mV |
| 2                   |           | 5        | 4        |             |

9. Tighten the VVEL control shaft position sensor mounting bolts.



**7.0 N•m (0.71 kg-m, 62 in-lb)**

10. Reconfirm that the output voltage of VVEL control shaft position sensor is within the standard value.

| VVEL control module |           |          |          | Voltage     |
|---------------------|-----------|----------|----------|-------------|
| Bank                | Connector | +        | -        |             |
|                     |           | Terminal | Terminal |             |
| 1                   | E15       | 3        | 6        | 500 ± 48 mV |
| 2                   |           | 5        | 4        |             |

**NOTE:**

If it varies from the standard value after the mounting bolts are tightened, perform steps 7 to 9 again.

11. Turn ignition switch OFF and wait at least 10 seconds.
12. Start engine and warm it up to normal operating temperature.
13. Turn ignition switch OFF and wait at least 10 seconds.
14. Perform Idle Air Volume Learning. Refer to [EC-1687, "Work Procedure"](#).

>> INSPECTION END

# MIXTURE RATIO SELF-LEARNING VALUE CLEAR

< BASIC INSPECTION >

[VK56VD FOR MEXICO]

## MIXTURE RATIO SELF-LEARNING VALUE CLEAR

### Description

INFOID:000000007758202

This describes how to erase the mixture ratio self-learning value. For the actual procedure, follow the instructions in "Diagnosis Procedure".

### Work Procedure

INFOID:000000007758203

#### 1. START

##### With CONSULT

1. Start engine and warm it up to normal operating temperature.
2. Select "SELF-LEARNING CONT" in "WORK SUPPORT" mode with CONSULT.
3. Clear mixture ratio self-learning value by touching "CLEAR".

##### With GST

1. Start engine and warm it up to normal operating temperature.
2. Turn ignition switch OFF.
3. Disconnect mass air flow sensor (bank 1) harness connector.
4. Restart engine and let it idle for at least 5 seconds.
5. Stop engine and reconnect mass air flow sensor (bank 1) harness connector.
6. Select Service \$03 with GST. Check DTC P0102 is detected.
7. Select Service \$04 with GST to erase the DTC P0102.

>> END

A

EC

C

D

E

F

G

H

I

J

K

L

M

N

O

P

## FUEL PRESSURE

### Work Procedure

INFOID:000000007758204

### FUEL PRESSURE RELEASE

#### Ⓜ WITH CONSULT

1. Turn ignition switch ON.
2. Perform "FUEL PRESSURE RELEASE" in "WORK SUPPORT" mode with CONSULT.
3. Start engine.
4. After engine stalls, crank it two or three times to release all fuel pressure.
5. Turn ignition switch OFF.

#### ⓧ WITHOUT CONSULT

1. Remove fuel pump fuse in IPDM E/R.  
**NOTE:**
  - For the fuse number, refer to [EC-1667, "Wiring Diagram"](#).
  - For the fuse arrangement, refer to [PG-40, "Fuse, Connector and Terminal Arrangement"](#).
2. Start engine.
3. After engine stalls, crank it two or three times to release all fuel pressure.
4. Turn ignition switch OFF.
5. Reinstall fuel pump fuse after servicing fuel system.

### LOW FUEL PRESSURE CHECK

#### CAUTION:

- Before disconnecting fuel line, release fuel pressure from fuel line to eliminate danger.
- The fuel hose connection method used when taking fuel pressure check must not be used for other purposes.
- Be careful not to scratch or put debris around connection area when servicing, so that the quick connector maintains seal ability with O-rings inside.
- Do not perform fuel pressure check with electrical systems operating (i.e. lights, rear defogger, A/C, etc.) Fuel pressure gauge may indicate false readings due to varying engine load and changes in manifold vacuum.

#### NOTE:

Prepare pans or saucers under the disconnected fuel line because the fuel may spill out. The fuel pressure cannot be completely released because this models do not have fuel return system.

1. Release fuel pressure to zero.
2. Prepare fuel hose for fuel pressure check (B) and fuel tube adapter [SST (KV10120000)] (D), then connect fuel pressure gauge (A).

- ⇐ To quick connector
- ← To fuel tube (engine side)
- C : Hose clamp

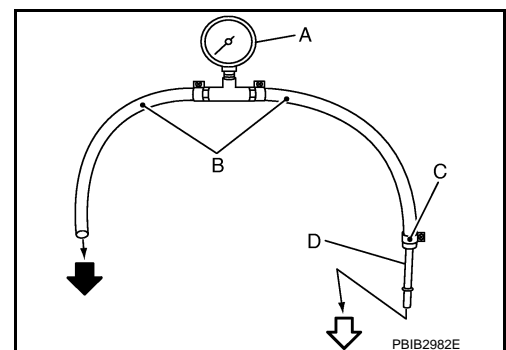

#### CAUTION:

- Use suitable fuel hose for fuel pressure check (genuine NISSAN fuel hose without quick connector).
  - To avoid unnecessary force or tension to hose, use moderately long fuel hose for fuel pressure check.
  - Do not use the fuel hose for checking fuel pressure with damage or cracks on it.
  - Use Pressure Gauge to check fuel pressure.
3. Disconnect fuel feed hose from fuel tube. Refer to [EM-193, "Exploded View"](#).

#### CAUTION:

Do not twist or kink fuel hose because it is plastic hose.

# FUEL PRESSURE

## < BASIC INSPECTION >

[VK56VD FOR MEXICO]

4. Connect fuel hose for fuel pressure check (1) to fuel tube (engine side) with clamp (2) as shown in the figure.

5 : No.2 spool

### CAUTION:

- Wipe off oil or dirt from hose insertion part using cloth moistened with gasoline.
- Apply proper amount of gasoline between top of the fuel tube (3) and No.1 spool (4).
- Insert fuel hose for fuel pressure check until it touches the No.1 spool on fuel tube.
- Use NISSAN genuine hose clamp (part number: 16439 N4710 or 16439 40U00).
- When reconnecting fuel line, always use new clamps.
- Use a torque driver to tighten clamps.
- Install hose clamp to the position within 1 - 2 mm (0.04 - 0.08 in).

**Tightening torque** : 1 - 1.5 N·m (0.1 - 0.15 kg·m, 9 - 13 in·lb)

- Make sure that clamp screw does not contact adjacent parts.

5. Connect fuel tube adapter (C) to quick connector (1).

A : Fuel pressure gauge

B : Fuel hose for fuel pressure check

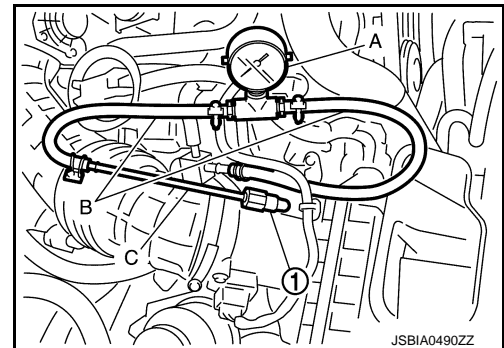
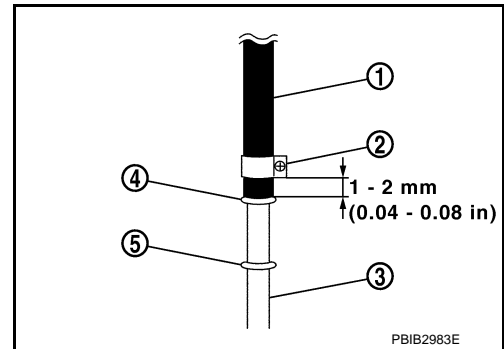

6. After connecting fuel hose for fuel pressure check, pull the hose with a force of approximately 98 N (10 kg, 22 lb) to confirm fuel tube does not come off.
7. Reinstall the part removed at Step 3.
- NOTE:**  
Install the part to allow smooth engine starts.
8. Turn ignition switch ON and check for fuel leakage.
9. Start engine and check for fuel leakage.
10. Read the indication of fuel pressure gauge.

### CAUTION:

- Do not perform fuel pressure check with system operating. Fuel pressure gauge may indicate false readings.
- During fuel pressure check, confirm for fuel leakage from fuel connection every 3 minutes.

**At idling** : Approximately 450 kPa (4.5 bar, 4.6 kg/cm<sup>2</sup>, 65 psi)

## HIGH FUEL PRESSURE CHECK

### NOTE:

Since the fuel pressure gauge kit cannot be connected, follow the method shown below to check high fuel pressure.

Ⓜ WITH CONSULT

1. Start engine.
2. Check "FUEL PRES SEN V" in "DATA MONITOR" mode with CONSULT.

# FUEL PRESSURE

< BASIC INSPECTION >

[VK56VD FOR MEXICO]

| Monitor Item    | Condition                                    | Values/Status  |
|-----------------|--|----------------|
| FUEL PRES SEN V | Idle   | 820 – 1,220 mV |
|                 | Reving engine from idle to 4,000 rpm quickly | 820 – 3,060 mV |

**⊗ WITHOUT CONSULT**

1. Start engine.
2. Check the voltage between ECM harness connector and ground.

| ECM       |          |           |          | Condition   | Voltage       |
|-----------|----------|-----------|----------|---|---------------|
| +         |          | -         |          |   |               |
| Connector | Terminal | Connector | Terminal |   |               |
| F110      | 31       | F110      | 40       | [Engine is running]<br>• Warm-up condition<br>• Idle speed                                    | 0.82 - 1.22 V |
|           |          |           |          | [Engine is running]<br>• Warm-up condition<br>• Revving engine from idle to 4,000 rpm quickly | 0.82 - 3.06 V |

# HOW TO SET SRT CODE

< BASIC INSPECTION >

[VK56VD FOR MEXICO]

## HOW TO SET SRT CODE

### Description

INFOID:000000007758205

### OUTLINE

In order to set all SRTs, the self-diagnoses as in the "SRT ITEM" table must have been performed at least once. Each diagnosis may require actual driving for a long period of time under various conditions.

### SRT ITEM

The table below shows required self-diagnostic items to set the SRT to "CMPLT".

| SRT item*1<br>(CONSULT indication) | Required self-diagnostic items to set the SRT to "CMPLT" | Corresponding DTC No.      |
|------------------------------------|--|----------------------------|
| CATALYST                           | Three way catalyst function                              | P0420, P0430               |
| HO2S                               | Air fuel ratio (A/F) sensor 1                            | P0130, P0133, P0150, P0153 |
|                                    | Heated oxygen sensor 2                                   | P0137, P0157               |
|                                    | Heated oxygen sensor 2                                   | P0138, P0158               |
|                                    | Heated oxygen sensor 2                                   | P0139, P0159               |
| EGR/VVT SYSTEM                     | Intake valve timing control function                     | P0011, P0021               |

\*1: Though displayed on the CONSULT screen, "HO2S HTR" is not SRT item.

### SRT SERVICE PROCEDURE

If a vehicle has failed the state emissions inspection due to one or more SRT items indicating "INCMP", review the flowchart diagnostic sequence on the next page.

# HOW TO SET SRT CODE

< BASIC INSPECTION >

[VK56VD FOR MEXICO]

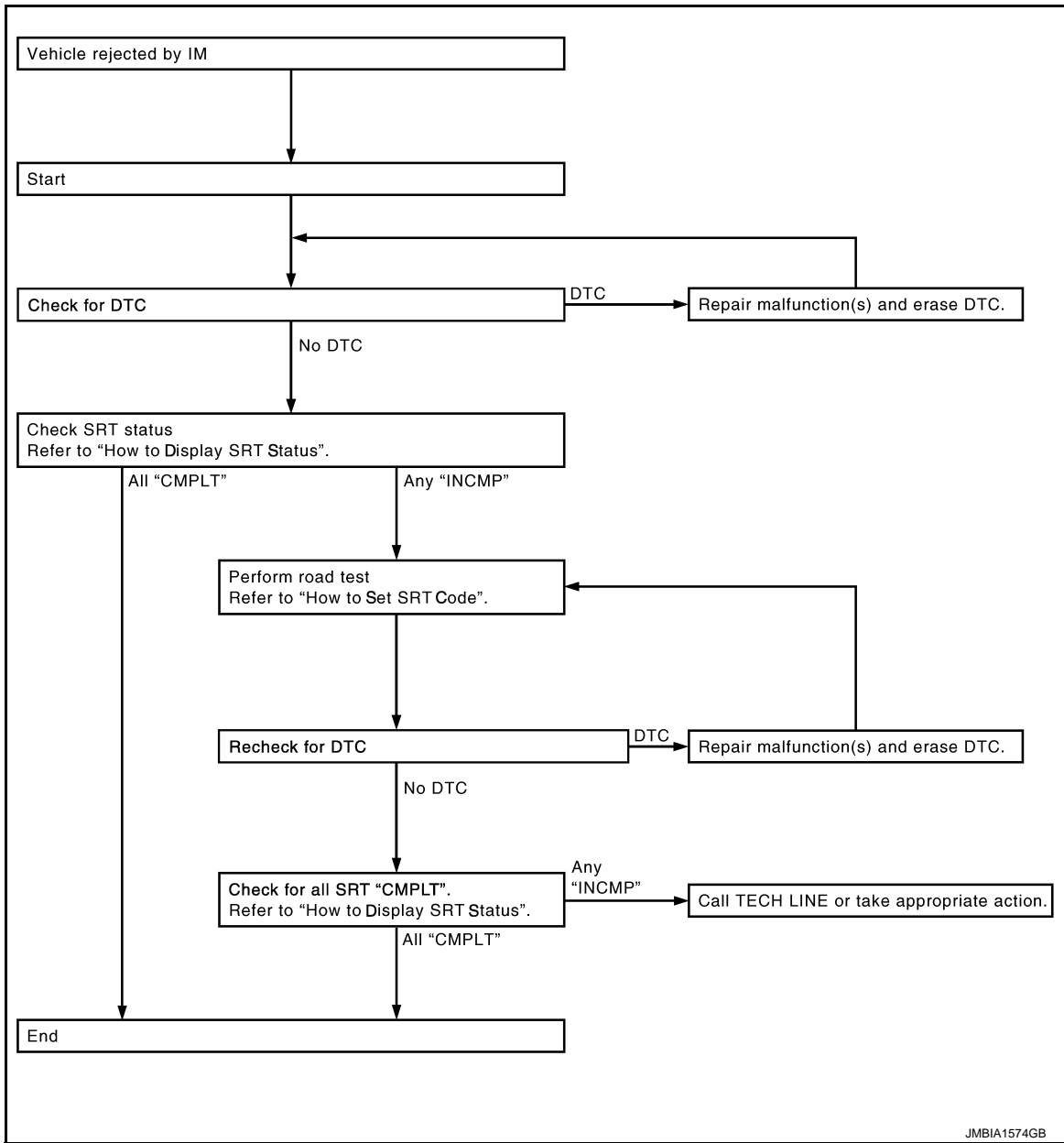

## SRT Set Driving Pattern

INFOID:000000007758206

**CAUTION:**



# HOW TO SET SRT CODE

< BASIC INSPECTION >

[VK56VD FOR MEXICO]

Always drive the vehicle in safe manner according to traffic conditions and obey all traffic laws.

**Note: Always drive vehicle in safe manner according to traffic conditions and obey all traffic laws. Refer to next page for more information and explanation of chart.**

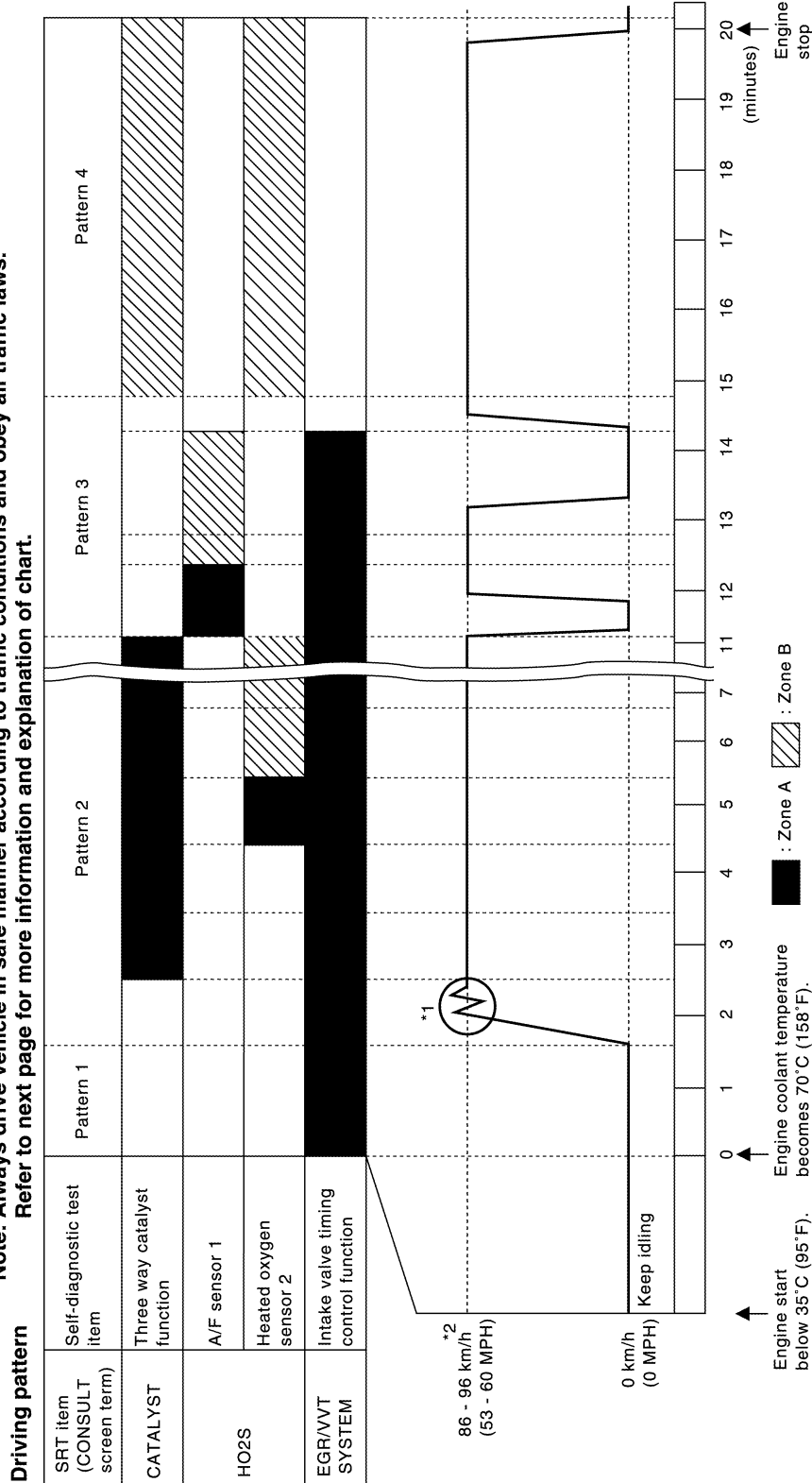

\*1: Depress the accelerator pedal until vehicle speed is 90 km/h (56 MPH), then release the accelerator pedal and keep it released for more than 10 seconds. Depress the accelerator pedal until vehicle speed is 90 km/h (56 MPH) again.

\*2: Checking the vehicle speed with GST is advised.

- The time required for each diagnosis varies with road surface conditions, weather, altitude, individual driving habits, etc.

Zone A refers to the range where the time, required for the diagnosis under normal conditions\*, is the shortest.

A  
EC  
C  
D  
E  
F  
G  
H  
I  
J  
K  
L  
M  
N  
O  
P

# HOW TO SET SRT CODE

[VK56VD FOR MEXICO]

## < BASIC INSPECTION >

Zone B refers to the range where the diagnosis can still be performed if the diagnosis is not completed within zone A.

\*: Normal conditions refer to the following:

- Sea level
  - Flat road
  - Ambient air temperature: 20 - 30°C (68 - 86°F)
  - Diagnosis is performed as quickly as possible under normal conditions.
- Under different conditions [For example: ambient air temperature other than 20 - 30°C (68 - 86°F)], diagnosis may also be performed.

## Work Procedure

INFOID:000000007758207

### 1. CHECK DTC

Check DTC.

Is any DTC detected?

YES >> Repair malfunction(s) and erase DTC. Refer to [EC-1651, "DTC Index"](#).

NO >> GO TO 2.

### 2. CHECK SRT STATUS

WITH CONSULT

Select "SRT STATUS" in "DTC & SRT CONFIRMATION" mode with CONSULT.

WITHOUT CONSULT

Perform "SRT status" mode with [EC-1612, "On Board Diagnosis Function"](#).

WITH GST

Select Service \$01 with GST (Generic Scan Tool).

Is SRT code(s) set?

YES >> END

NO-1 >> With CONSULT: GO TO 3.

NO-2 >> Without CONSULT: GO TO 4.

### 3. DTC CONFIRMATION PROCEDURE

1. Select "SRT WORK SUPPORT" in "DTC & SRT CONFIRMATION" mode with CONSULT.
2. For SRT(s) that is not set, perform the corresponding "DTC CONFIRMATION PROCEDURE" according to the "Performance Priority" in the "SRT ITEM" table. Refer to [EC-1695, "Description"](#).
3. Check DTC.

Is any DTC detected?

YES >> Repair malfunction(s) and erase DTC. Refer to [EC-1651, "DTC Index"](#).

NO >> GO TO 9.

### 4. PERFORM ROAD TEST

- Check the "Performance Priority" in the "SRT ITEM" table. Refer to [EC-1695, "Description"](#).
- Perform the most efficient SRT set driving pattern to set the SRT properly. Refer to [EC-1696, "SRT Set Driving Pattern"](#).

In order to set all SRTs, the SRT set driving pattern must be performed at least once.

>> GO TO 5.

### 5. PATTERN 1

1. Check the vehicle condition;
  - Engine coolant temperature is -10 to 35°C (14 to 95°F).
  - Fuel tank temperature is more than 0°C (32°F).
2. Start the engine.
3. Keep engine idling until the engine coolant temperature is greater than 70°C (158°F)

#### NOTE:

ECM terminal voltage is follows;

- Engine coolant temperature
  - -10 to 35°C (14 to 95°F): 3.0 - 4.3 V
  - 70°(158°F): Less than 1.4 V

# HOW TO SET SRT CODE

[VK56VD FOR MEXICO]

## < BASIC INSPECTION >

- Fuel tank temperature: Less than 4.1 V  
Refer to [EC-1624, "Reference Value"](#).

>> GO TO 6.

### 6.PATTERN 2

- Drive the vehicle. And depress the accelerator pedal until vehicle speed is 90 km/h (56 MPH), then release the accelerator pedal and keep it released for more than 10 seconds.
- Depress the accelerator pedal until vehicle speed is 90 km/h (56 MPH) again

#### NOTE:

- Checking the vehicle speed with GST is advised.
- When steady-state driving is performed again even after it is interrupted, each diagnosis can be conducted. In this case, the time required for diagnosis may be extended.

>> GO TO 7.

### 7.PATTERN 3

- Operate vehicle following the driving pattern shown in the figure.
- Release the accelerator pedal during deceleration of vehicle speed from 90 km/h (56 MPH) to 0 km/h (0 MPH).

>> GO TO 8.

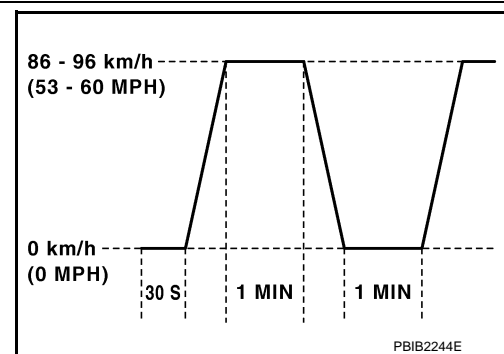

### 8.PATTERN 4

- The accelerator pedal must be held very steady during steady-state driving.
- If the accelerator pedal is moved, the test must be conducted again.

>> GO TO 9.

### 9.CHECK SRT STATUS

#### WITH CONSULT

Select "SRT STATUS" in "DTC & SRT CONFIRMATION" mode with CONSULT.

#### WITHOUT CONSULT

Perform "SRT status" mode with [EC-1612, "On Board Diagnosis Function"](#).

#### WITH GST

Select Service \$01 with GST (Generic Scan Tool).

#### Is SRT(s) set?

- YES >> END
- NO >> Call TECH LINE or take appropriate action.

## DTC/CIRCUIT DIAGNOSIS

### TROUBLE DIAGNOSIS - SPECIFICATION VALUE

#### Description

INFOID:000000007758208

The specification (SP) value indicates the tolerance of the value that is displayed in "SPEC" in "DATA MONITOR" mode of CONSULT during normal operation of the Engine Control System. When the value in "SPEC" in "DATA MONITOR" mode is within the SP value, the Engine Control System is confirmed OK. When the value in "SPEC" in "DATA MONITOR" mode is NOT within the SP value, the Engine Control System may have one or more malfunctions.

The SP value is used to detect malfunctions that may affect the Engine Control System, but will not illuminate the MIL.

The SP value will be displayed for the following items:

- B/FUEL SCHDL (The fuel injection pulse width programmed into ECM prior to any learned on board correction)
- A/F ALPHA-B1/B2 (The mean value of air-fuel ratio feedback correction factor per cycle)
- MAS A/F SE-B1/B2 (The signal voltage of the mass air flow sensor)
- IDLE FUEL PRES MAX/MIN (the signal voltage of the fuel rail pressure sensor)

#### Component Function Check

INFOID:000000007758209

### 1. PRECONDITIONING

Check that all of the following conditions are satisfied.

#### TESTING CONDITION

- Vehicle driven distance: More than 5,000 km (3,107 miles)
- Barometric pressure: 98.3 - 104.3 kPa (0.983 - 1.043 bar, 1.003 - 1.064 kg/cm<sup>2</sup>, 14.25 - 15.12 psi)
- Atmospheric temperature: 20 - 30°C (68 - 86°F)
- Engine coolant temperature: 75 - 95°C (167 - 203°F)
- Transmission: Warmed-up
- After the engine is warmed up to normal operating temperature, drive vehicle until "ATF TEMP 2" (A/T fluid temperature sensor signal) indicates more than 60°C (140°F).
- Electrical load: Not applied
- Rear window defogger switch, air conditioner switch and lighting switch are OFF. Steering wheel is straight ahead.
- Engine speed: Idle
- Gear position: Neutral ( or parking)

>> GO TO 2.

### 2. PERFORM SPEC IN DATA MONITOR MODE

#### Ⓟ WITH CONSULT

#### NOTE:

Perform "SPEC" in "DATA MONITOR" mode in maximum scale display.

1. Perform basic inspection. Refer to [EC-1679. "Work Procedure"](#).
2. Select "B/FUEL SCHDL", "A/F ALPHA-B1", "A/F ALPHA-B2", "MAS A/F SE-B1" and "MAS A/F SE-B2" in "SPEC" of "DATA MONITOR" mode with CONSULT.
3. Check that monitor items are within the SP value.

Is the measurement value within the SP value?

- YES >> INSPECTION END  
 NO >> Proceed to [EC-1701. "Diagnosis Procedure"](#).

# TROUBLE DIAGNOSIS - SPECIFICATION VALUE

< DTC/CIRCUIT DIAGNOSIS >

[VK56VD FOR MEXICO]

## Diagnosis Procedure

INFOID:000000007758210

### OVERALL SEQUENCE

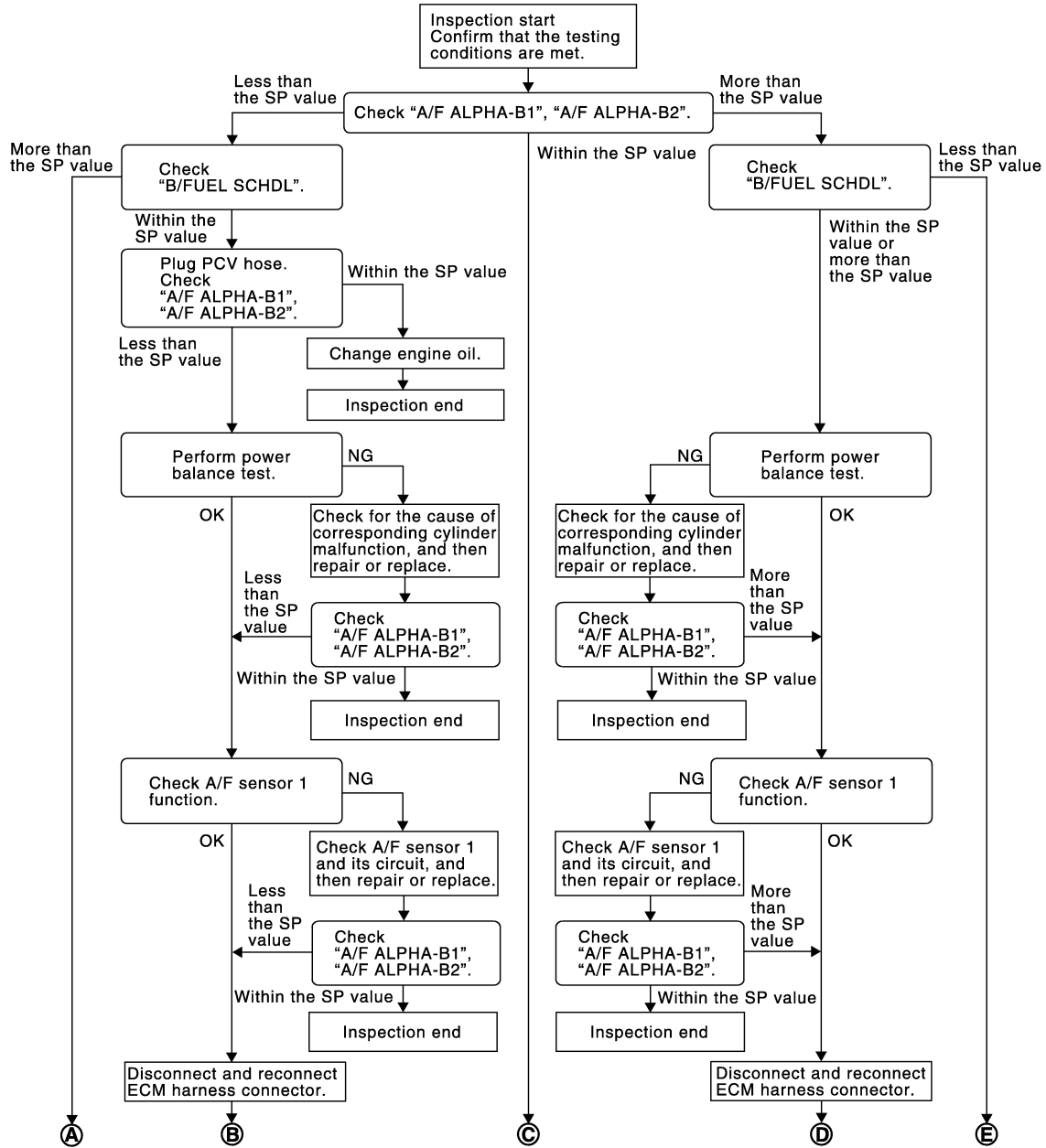

JSBIA0519GB

# TROUBLE DIAGNOSIS - SPECIFICATION VALUE

< DTC/CIRCUIT DIAGNOSIS >

[VK56VD FOR MEXICO]

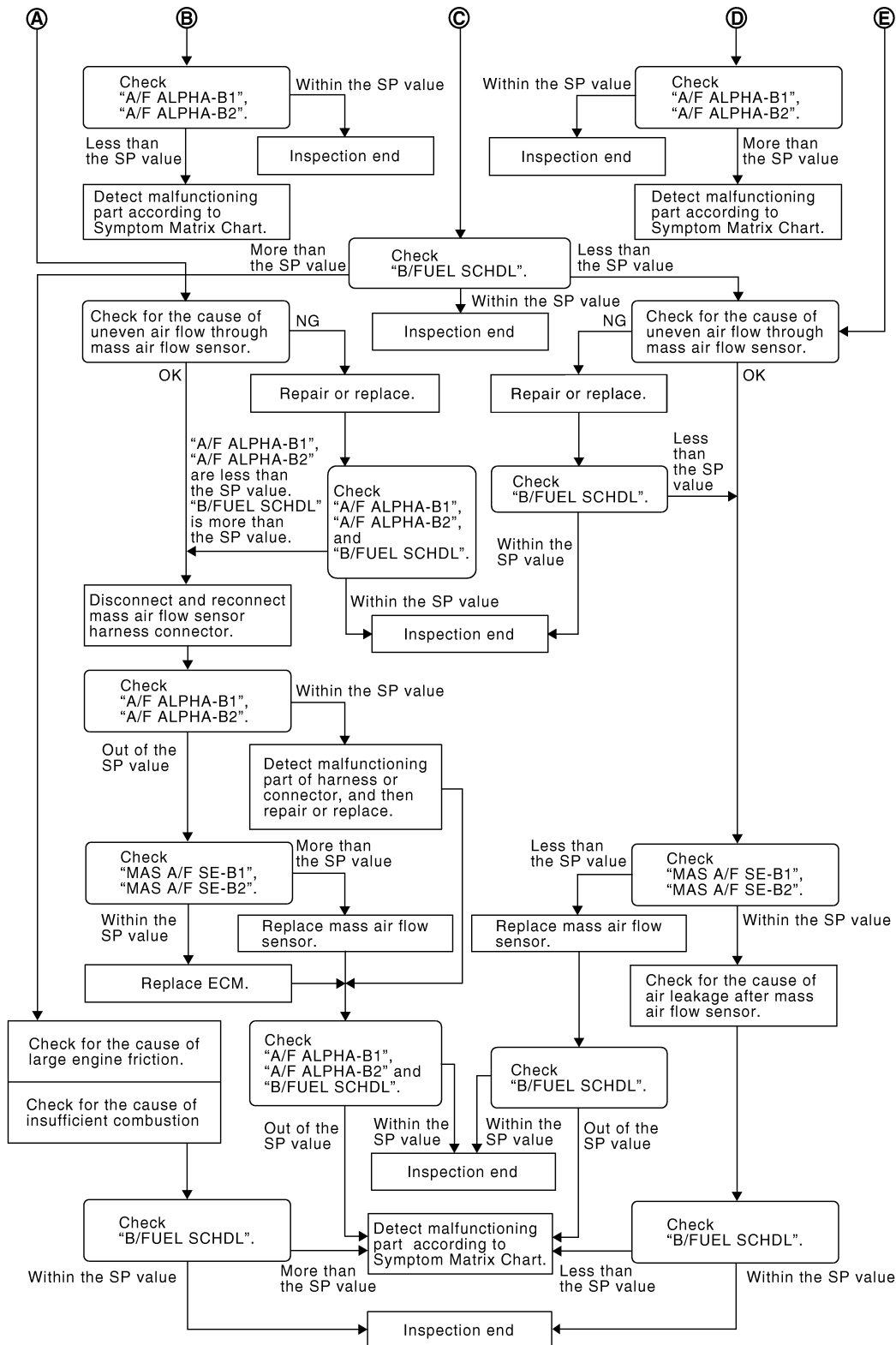

JMBIA0056GB

## DETAILED PROCEDURE

### 1. CHECK "A/F ALPHA-B1" AND "A/F ALPHA-B2"

#### Ⓟ WITH CONSULT

1. Start engine.
2. Check that the testing conditions are met. Refer to [EC-1700, "Component Function Check"](#).
3. Select "A/F ALPHA-B1" and "A/F ALPHA-B2" in "SPEC" of "DATA MONITOR" mode, and check that each indication is within the SP value.

# TROUBLE DIAGNOSIS - SPECIFICATION VALUE

< DTC/CIRCUIT DIAGNOSIS >

[VK56VD FOR MEXICO]

## NOTE:

Check "A/F ALPHA-B1" and "A/F ALPHA-B2" for approximately 1 minute because they may fluctuate. It is NG if the indication is out of the SP value even a little.

Is the measurement value within the SP value?

YES >> GO TO 14.

NO-1 >> Less than the SP value: GO TO 2.

NO-2 >> More than the SP value: GO TO 3.

## 2.CHECK "B/FUEL SCHDL"

Select "B/FUEL SCHDL" in "SPEC" of "DATA MONITOR" mode, and check that the indication is within the SP value.

Is the measurement value within the SP value?

YES >> GO TO 4.

NO >> More than the SP value: GO TO 16.

## 3.CHECK "B/FUEL SCHDL"

Select "B/FUEL SCHDL" in "SPEC" of "DATA MONITOR" mode, and check that the indication is within the SP value.

Is the measurement value within the SP value?

YES >> GO TO 6.

NO-1 >> More than the SP value: GO TO 6.

NO-2 >> Less than the SP value: GO TO 22.

## 4.CHECK "A/F ALPHA-B1", "A/F ALPHA-B2"

1. Stop the engine.

2. Disconnect PCV hose, and then plug it.

3. Start engine.

4. Select "A/F ALPHA-B1" and "A/F ALPHA-B2" in "SPEC" of "DATA MONITOR" mode, and check that each indication is within the SP value.

Is the measurement value within the SP value?

YES >> GO TO 5.

NO >> GO TO 6.

## 5.CHANGE ENGINE OIL

1. Stop the engine.

2. Change engine oil.

## NOTE:

This symptom may occur when a large amount of gasoline is mixed with engine oil because of driving conditions (such as when engine oil temperature does not rise enough since a journey distance is too short during winter). The symptom will not be detected after changing engine oil or changing driving conditions.

>> INSPECTION END

## 6.PERFORM POWER BALANCE TEST

1. Perform "POWER BALANCE" in "ACTIVE TEST" mode.

2. Check that each cylinder produces a momentary engine speed drop.

Is the inspection result normal?

YES >> GO TO 9.

NO >> GO TO 7.

## 7.DETECT MALFUNCTIONING PART

Check the following below.

- Ignition coil and its circuit (Refer to [EC-1984, "Component Function Check".](#))
- Fuel injector and its circuit (Refer to [EC-1976, "Component Function Check".](#))
- Intake air leakage
- Low compression pressure (Refer to [EM-172, "Inspection".](#))

Is the inspection result normal?

## TROUBLE DIAGNOSIS - SPECIFICATION VALUE

< DTC/CIRCUIT DIAGNOSIS >

[VK56VD FOR MEXICO]

- YES >> Replace fuel injector. Refer to [EM-197, "Removal and Installation"](#). And then GO TO 8.  
NO >> Repair or replace malfunctioning part and then GO TO 8.

### 8.CHECK "A/F ALPHA-B1" AND "A/F ALPHA-B2"

1. Start engine.
2. Select "A/F ALPHA-B1" and "A/F ALPHA-B2" in "SPEC" of "DATA MONITOR" mode, and check that each indication is within the SP value.

Is the measurement value within the SP value?

- YES >> INSPECTION END  
NO >> GO TO 9.

### 9.CHECK A/F SENSOR 1 FUNCTION

Perform all DTC CONFIRMATION PROCEDURE related with A/F sensor 1.

- For DTC P0130, P0150, refer to [EC-1764, "DTC Logic"](#).
- For DTC P0131, P0151, refer to [EC-1768, "DTC Logic"](#).
- For DTC P0132, P0152, refer to [EC-1771, "DTC Logic"](#).
- For DTC P0133, P0153, refer to [EC-1774, "DTC Logic"](#).

Are any DTCs detected?

- YES >> GO TO 10.  
NO >> GO TO 12.

### 10.CHECK A/F SENSOR 1 CIRCUIT

Perform Diagnosis Procedure according to corresponding DTC.

>> GO TO 11.

### 11.CHECK "A/F ALPHA-B1" AND "A/F ALPHA-B2"

1. Start engine.
2. Select "A/F ALPHA-B1" and "A/F ALPHA-B2" in "SPEC" of "DATA MONITOR" mode, and check that each indication is within the SP value.

Is the measurement value within the SP value?

- YES >> INSPECTION END  
NO >> GO TO 12.

### 12.DISCONNECT AND RECONNECT ECM HARNESS CONNECTOR

1. Stop the engine.
2. Disconnect ECM harness connector. Check pin terminal and connector for damage, and then reconnect it.

>> GO TO 13.

### 13.CHECK "A/F ALPHA-B1" AND "A/F ALPHA-B2"

1. Start engine.
2. Select "A/F ALPHA-B1" and "A/F ALPHA-B2" in "SPEC" of "DATA MONITOR" mode, and check that each indication is within the SP value.

Is the measurement value within the SP value?

- YES >> INSPECTION END  
NO >> Detect malfunctioning part according to [EC-2003, "Symptom Table"](#).

### 14.CHECK "B/FUEL SCHDL"

Select "B/FUEL SCHDL" in "SPEC" of "DATA MONITOR" mode, and check that the indication is within the SP value.

Is the measurement value within the SP value?

- YES >> INSPECTION END  
NO-1 >> More than the SP value: GO TO 15.  
NO-2 >> Less than the SP value: GO TO 22.

### 15.DETECT MALFUNCTIONING PART

1. Check for the cause of large engine friction. Refer to the following.



# TROUBLE DIAGNOSIS - SPECIFICATION VALUE

[VK56VD FOR MEXICO]

## < DTC/CIRCUIT DIAGNOSIS >

- Engine oil level is too high
  - Engine oil viscosity
  - Belt tension of power steering, alternator, A/C compressor, etc. is excessive
  - Noise from engine
  - Noise from transmission, etc.
2. Check for the cause of insufficient combustion. Refer to the following.
- Valve clearance malfunction
  - Intake valve timing control function malfunction
  - Camshaft sprocket installation malfunction, etc.

>> Repair or replace malfunctioning part, and then GO TO 27.

## 16. CHECK INTAKE SYSTEM

Check for the cause of uneven air flow through mass air flow sensor. Refer to the following.

- Crushed air ducts
- Malfunctioning seal of air cleaner element
- Uneven dirt of air cleaner element
- Improper specification of intake air system

Is the inspection result normal?

YES >> GO TO 18.

NO >> Repair or replace malfunctioning part, and then GO TO 17.

## 17. CHECK "A/F ALPHA-B1", "A/F ALPHA-B2" AND "B/FUEL SCHDL"

Select "A/F ALPHA-B1", "A/F ALPHA-B2" and "B/FUEL SCHDL" in "SPEC" of "DATA MONITOR" mode, and check that each indication is within the SP value.

Is the measurement value within the SP value?

YES >> INSPECTION END

NO >> "B/FUEL SCHDL" is more, "A/F ALPHA-B1" and "A/F ALPHA-B2" are less than the SP value: GO TO 18.

## 18. DISCONNECT AND RECONNECT MASS AIR FLOW SENSOR HARNESS CONNECTOR

1. Stop the engine.
2. Disconnect mass air flow sensor harness connector. Check pin terminal and connector for damage and then reconnect it again.

>> GO TO 19.

## 19. CHECK "A/F ALPHA-B1" AND "A/F ALPHA-B2"

1. Start engine.
2. Select "A/F ALPHA-B1" and "A/F ALPHA-B2" in "SPEC" of "DATA MONITOR" mode, and check that each indication is within the SP value.

Is the measurement value within the SP value?

YES >> Detect malfunctioning part of mass air flow sensor circuit and repair it. Refer to [EC-1749. "DTC Logic"](#). Then GO TO 26.

NO >> GO TO 20.

## 20. CHECK "MAS A/F SE-B1" AND "MAS A/F SE-B2"

Select "MAS A/F SE-B1" and "MAS A/F SE-B2" in "SPEC" of "DATA MONITOR" mode, and check that the indication is within the SP value.

Is the measurement value within the SP value?

YES >> GO TO 21.

NO >> More than the SP value: Replace malfunctioning mass air flow sensor. Refer to [EM-184. "Removal and Installation"](#). And then GO TO 26.

## 21. REPLACE ECM

Replace ECM. Refer to [EC-2013. "Removal and Installation"](#)

>> GO TO 26.

## TROUBLE DIAGNOSIS - SPECIFICATION VALUE

< DTC/CIRCUIT DIAGNOSIS >

[VK56VD FOR MEXICO]

---

### 22.CHECK INTAKE SYSTEM

---

Check for the cause of uneven air flow through mass air flow sensor. Refer to the following.

- Crushed air ducts
- Malfunctioning seal in air cleaner element
- Uneven dirt in air cleaner element
- Improper specification in intake air system

Is the inspection result normal?

YES >> GO TO 24.

NO >> Repair or replace malfunctioning part, and then GO TO 23.

---

### 23.CHECK "B/FUEL SCHDL"

---

Select "B/FUEL SCHDL" in "SPEC" of "DATA MONITOR" mode, and check that the indication is within the SP value.

Is the measurement value within the SP value?

YES >> INSPECTION END

NO >> Less than the SP value: GO TO 24.

---

### 24.CHECK "MAS A/F SE-B1" AND "MAS A/F SE-B2"

---

Select "MAS A/F SE-B1" and "MAS A/F SE-B2" in "SPEC" of "DATA MONITOR" mode, and check that the indication is within the SP value.

Is the measurement value within the SP value?

YES >> GO TO 25.

NO >> Less than the SP value: Replace malfunctioning mass air flow sensor. Refer to [EM-184, "Removal and Installation"](#). And then GO TO 27.

---

### 25.CHECK INTAKE SYSTEM

---

Check for the cause of air leakage after the mass air flow sensor. Refer to the following.

- Disconnection, looseness, and cracks in air duct
- Looseness of oil filler cap
- Disconnection of oil level gauge
- Open stuck, breakage, hose disconnection, or cracks in PCV valve
- Disconnection or cracks in EVAP purge hose, stuck open EVAP canister purge volume control solenoid valve
- Malfunctioning seal in rocker cover gasket
- Disconnection, looseness, or cracks in hoses, such as a vacuum hose, connecting to intake air system parts
- Malfunctioning seal in intake air system, etc.

>> GO TO 27.

---

### 26.CHECK "A/F ALPHA-B1", "A/F ALPHA-B2" AND "B/FUEL SCHDL"

---

Select "A/F ALPHA-B1", "A/F ALPHA-B2" and "B/FUEL SCHDL" in "SPEC" of "DATA MONITOR" mode, and check that each indication is within the SP value.

Is the measurement value within the SP value?

YES >> INSPECTION END

NO >> Detect malfunctioning part according to [EC-2003, "Symptom Table"](#).

---

### 27.CHECK "B/FUEL SCHDL"

---

Select "B/FUEL SCHDL" in "SPEC" of "DATA MONITOR" mode, and then check that the indication is within the SP value.

Is the measurement value within the SP value?

YES >> INSPECTION END

NO >> Detect malfunctioning part according to [EC-2003, "Symptom Table"](#).

# POWER SUPPLY AND GROUND CIRCUIT

< DTC/CIRCUIT DIAGNOSIS >

[VK56VD FOR MEXICO]

## POWER SUPPLY AND GROUND CIRCUIT

### Diagnosis Procedure

INFOID:000000007758211

#### 1.CHECK FUSE

Check that the following fuse is not fusing.

| Location | Fuse No. | Capacity |
|----------|----------|----------|
| IPDM E/R | #51      | 15A      |
|          | #42      | 10A      |

Is the fuse fusing?

YES >> Replace the fuse after repairing the applicable circuit.

NO >> GO TO 2.

#### 2.CHECK GROUND CONNECTION

1. Check ground connection M11, M95 and M95. Refer to [PG-49. "Main Harness"](#).

Is the inspection result normal?

YES >> GO TO 3.

NO >> Repair or replace ground connection.

#### 3.CHECK ECM GROUND CIRCUIT

1. Disconnect ECM harness connector.
2. Check the continuity between ECM harness connector and ground.

| ECM       |          | Ground | Continuity |
|-----------|----------|--------|------------|
| Connector | Terminal |        |            |
| F110      | 5        | Ground | Existed    |
|           | 10       |        |            |
| M160      | 114      |        |            |
|           | 115      |        |            |
|           | 174      |        |            |
|           | 175      |        |            |

3. Also check harness for short to power.

Is the inspection result normal?

YES >> GO TO 4.

NO >> Repair open circuit in harness or connectors.

#### 4.CHECK ECM POWER SUPPLY (MAIN)-1

1. Reconnect ECM harness connector.
2. Turn ignition switch ON.
3. Check the voltage between ECM harness connector and ground.

| ECM       |          |           |          | Voltage<br>(Approx.) |
|-----------|----------|-----------|----------|----------------------|
| +         |          | -         |          |                      |
| Connector | Terminal | Connector | Terminal |                      |
| M160      | 171      | M160      | 175      | Battery voltage      |
|           | 172      |           |          |                      |

Is the inspection result normal?

YES >> GO TO 6.

NO >> GO TO 5.

#### 5.CHECK ECM POWER SUPPLY (MAIN) CIRCUIT

# POWER SUPPLY AND GROUND CIRCUIT

< DTC/CIRCUIT DIAGNOSIS >

[VK56VD FOR MEXICO]

1. Turn ignition switch OFF.
2. Disconnect ECM harness connector and IPDM E/R harness connector.
3. Check the continuity between ECM harness connector and IPDM E/R harness connector.

| ECM       |          | IPDM E/R  |          | Continuity |
|-----------|----------|-----------|----------|------------|
| Connector | Terminal | Connector | Terminal |            |
| M160      | 171      | E5        | 6        | Existed    |
|           | 172      |           |          |            |

Is the inspection result normal?

YES >> Replace IPDM E/R. Refer to [PCS-33. "Removal and Installation"](#).

NO >> Repair harness or connectors.

## 6. CHECK ECM POWER SUPPLY (MAIN)-2

1. Turn ignition switch OFF and wait at least 10 seconds.
2. Check the voltage between ECM harness connector terminals as per the following.

| ECM       |          |           |          | Condition   | Voltage (Approx.) |
|-----------|----------|-----------|----------|---|-------------------|
| +         |          | -         |          |   |                   |
| Connector | Terminal | Connector | Terminal |   |                   |
| M160      | 171      | M160      | 175      | After turning ignition switch OFF, battery voltage will exist for a few seconds | Drop to 0 V.      |
|           | 172      |           |          |   |                   |

Is the inspection result normal?

YES >> GO TO 9.

NO >> GO TO 7.

## 7. CHECK ECM RELAY CONTROL SIGNAL

1. Check the voltage between ECM harness connector terminals as per the following.

| ECM       |          |           |          | Condition  | Voltage (Approx.) |
|-----------|----------|-----------|----------|--|-------------------|
| +         |          | -         |          |  |                   |
| Connector | Terminal | Connector | Terminal |  |                   |
| M160      | 163      | M160      | 175      | Ignition switch ON                                     | 0 V               |
|           |          |           |          | Turn ignition switch OFF and wait at least 10 seconds. | Battery voltage   |

Is the inspection result normal?

YES >> Check intermittent incident. Refer to [GI-44. "Intermittent Incident"](#).

NO >> GO TO 8.

## 8. CHECK ECM RELAY CONTROL CIRCUIT

1. Disconnect ECM harness connector.
2. Disconnect IPDM E/R harness connector.
3. Check the continuity between ECM harness connector and IPDM E/R harness connector.

| ECM       |          | IPDM E/R  |          | Continuity |
|-----------|----------|-----------|----------|------------|
| Connector | Terminal | Connector | Terminal |            |
| M160      | 163      | E7        | 70       | Existed    |

4. Also check harness for short to ground and short to power.

Is the inspection result normal?

YES >> Replace IPDM E/R. Refer to [PCS-33. "Removal and Installation"](#).

NO >> Repair harness or connectors.

# POWER SUPPLY AND GROUND CIRCUIT

< DTC/CIRCUIT DIAGNOSIS >

[VK56VD FOR MEXICO]

## 9. CHECK IGNITION SWITCH SIGNAL

1. Reconnect ECM harness connector.
2. Turn ignition switch ON.
3. Check the voltage between ECM harness connector terminals.

| ECM       |          |           |          | Condition           | Voltage (Approx.) |
|-----------|----------|-----------|----------|---------------------|-------------------|
| +         |          | -         |          |                     |                   |
| Connector | Terminal | Connector | Terminal |                     |                   |
| M160      | 141      | M160      | 175      | Ignition switch OFF | 0 V               |
|           |          |           |          | Ignition switch ON  | Battery voltage   |

Is the inspection result normal?

YES >> GO TO 11.

NO >> GO TO 10.

## 10. CHECK IGNITION SWITCH SIGNAL CIRCUIT

1. Disconnect ECM harness connector.
2. Disconnect IPDM E/R harness connector.
3. Check the continuity between ECM harness connector and IPDM E/R harness connector.

| ECM       |          | IPDM E/R  |          | Continuity |
|-----------|----------|-----------|----------|------------|
| Connector | Terminal | Connector | Terminal |            |
| M160      | 141      | E7        | 52       | Existed    |

4. Also check harness for short to ground and short to power.

Is the inspection result normal?

YES >> Replace IPDM E/R. Refer to [PCS-33, "Removal and Installation"](#).

NO >> Repair harness or connectors.

## 11. CHECK ECM POWER SUPPLY (BACK-UP)

1. Reconnect ECM harness connector.
2. Turn ignition switch OFF.
3. Check the voltage between ECM harness connector terminals.

| ECM       |          |           |          | Voltage (Approx.) |
|-----------|----------|-----------|----------|-------------------|
| +         |          | -         |          |                   |
| Connector | Terminal | Connector | Terminal |                   |
| M160      | 156      | M160      | 175      | Battery voltage   |

Is the inspection result normal?

YES >> INSPECTION END

NO >> GO TO 12.

## 12. CHECK ECM POWER SUPPLY (BACK-UP) CIRCUIT

1. Disconnect ECM harness connector.
2. Disconnect IPDM E/R harness connector.
3. Check the continuity between ECM harness connector and IPDM E/R harness connector.

| ECM       |          | IPDM E/R  |          | Continuity |
|-----------|----------|-----------|----------|------------|
| Connector | Terminal | Connector | Terminal |            |
| M160      | 156      | E5        | 10       | Existed    |

4. Also check harness for short to ground and short to power.

Is the inspection result normal?

YES >> Replace IPDM E/R. Refer to [PCS-33, "Removal and Installation"](#).

## POWER SUPPLY AND GROUND CIRCUIT

< DTC/CIRCUIT DIAGNOSIS >

[VK56VD FOR MEXICO]

---

NO >> Repair harness or connectors.

# U0101 CAN COMM CIRCUIT

< DTC/CIRCUIT DIAGNOSIS >

[VK56VD FOR MEXICO]

## U0101 CAN COMM CIRCUIT

### DTC Logic

INFOID:000000007758212

### DTC DETECTION LOGIC

| DTC No. | Trouble diagnosis name<br>(Trouble diagnosis content) | DTC detecting condition  | Possible cause   |
|---------|---|--|--|
| U0101   | LOST COMM (TCM)<br>(Lost communication with TCM)      | When ECM is not transmitting or receiving CAN communication signal of OBD (emission related diagnosis) with TCM for 2 seconds or more. | <ul style="list-style-type: none"><li>CAN communication line between TCM and ECM (CAN communication line is open or shorted)</li></ul> |

### DTC CONFIRMATION PROCEDURE

#### 1. PERFORM DTC CONFIRMATION PROCEDURE

1. Turn ignition switch ON and wait at least 3 seconds.
2. Check DTC.

#### Is DTC detected?

- YES >> Proceed to [EC-1711, "Diagnosis Procedure"](#).  
NO >> INSPECTION END

### Diagnosis Procedure

INFOID:000000007758213

Perform the trouble diagnosis for CAN communication system. Refer to [LAN-25, "Trouble Diagnosis Flow Chart"](#).

# U0113, U1003 CAN COMM CIRCUIT

< DTC/CIRCUIT DIAGNOSIS >

[VK56VD FOR MEXICO]

## U0113, U1003 CAN COMM CIRCUIT

### DTC Logic

INFOID:000000007758214

### DTC DETECTION LOGIC

#### NOTE:

If DTC U0113 or U1003 is displayed with DTC P0607, first perform the trouble diagnosis for DTC P0607. Refer to [EC-1860, "DTC Logic"](#).

| DTC No. | Trouble diagnosis name<br>(Trouble diagnosis content)             | DTC detecting condition  | Possible cause   |
|---------|---|--|--|
| U0113   | CAN COMM CIRCUIT<br>(Lost communication with VVEL control module) | When ECM is not transmitting or receiving CAN communication signal of OBD (emission related diagnosis) with VVEL control module for 2 seconds or more.         | <ul style="list-style-type: none"><li>• Harness or connectors (VVEL CAN communication line is open or shorted)</li><li>• ECM</li><li>• VVEL control module</li></ul> |
| U1003   |   | When ECM is not transmitting or receiving CAN communication signal other than OBD (emission related diagnosis) with VVEL control module for 2 seconds or more. |  |

### DTC CONFIRMATION PROCEDURE

#### 1. PRECONDITIONING

#### TESTING CONDITION:

Before performing the following procedure, confirm that battery voltage is 10 V or more at idle.

>> GO TO 2.

#### 2. PERFORM DTC CONFIRMATION PROCEDURE

1. Turn ignition switch ON and wait at least 3 seconds.
2. Check DTC.

#### Is DTC detected?

YES >> Proceed to [EC-1712, "Diagnosis Procedure"](#).  
NO >> INSPECTION END

### Diagnosis Procedure

INFOID:000000007758215

#### 1. CHECK VVEL CAN COMMUNICATION CIRCUIT

1. Turn ignition switch OFF.
2. Disconnect ECM harness connector.
3. Disconnect VVEL control module harness connector.
4. Check the continuity between ECM harness connector and VVEL control module harness connector.

| ECM       |          | VVEL control module |          | Continuity |
|-----------|----------|---------------------|----------|------------|
| Connector | Terminal | Connector           | Terminal |            |
| M160      | 161      | E15                 | 24       | Existed    |
|           | 166      |                     | 11       |            |

5. Also check harness for short to ground and short to power.

#### Is the inspection result normal?

YES >> GO TO 3.  
NO >> GO TO 2.

#### 2. DETECT MALFUNCTIONING PART

Check the following.

- Harness for open or short between ECM and VVEL control module
- Loose or poor connection for each connector and harness



# U0113, U1003 CAN COMM CIRCUIT

< DTC/CIRCUIT DIAGNOSIS >

[VK56VD FOR MEXICO]

>> Repair open circuit, short to ground or short to power in harness or connectors.

## 3. CHECK INTERMITTENT INCIDENT

Refer to [GI-44, "Intermittent Incident"](#).

Is the inspection result normal?

YES >> GO TO 4.

NO >> Repair or replace.

## 4. REPLACE VVEL CONTROL MODULE

Replace VVEL control module. Refer to [EC-2014, "Removal and Installation"](#).

>> GO TO 5.

## 5. PERFORM DTC CONFIRMATION PROCEDURE

### Ⓜ WITH CONSULT

1. Reconnect all harness connectors disconnected.
2. Turn ignition switch ON.
3. Select "SELF DIAGNOSTIC RESULT" mode with CONSULT.
4. Touch "ERASE".
5. Perform DTC Confirmation Procedure.  
See [EC-1712, "DTC Logic"](#).

### Ⓜ WITH GST

1. Reconnect all harness connectors disconnected.
2. Turn ignition switch ON.
3. Select Service \$04 with GST.
4. Perform DTC Confirmation Procedure.  
See [EC-1712, "DTC Logic"](#).

Is the DTC U0113 or U1003 displayed again?

YES >> GO TO 6.

NO >> INSPECTION END

## 6. REPLACE ECM

Replace ECM. Refer to [EC-2013, "Removal and Installation"](#).

>> INSPECTION END

A  
EC  
C  
D  
E  
F  
G  
H  
I  
J  
K  
L  
M  
N  
O  
P

# U1001 CAN COMM CIRCUIT

< DTC/CIRCUIT DIAGNOSIS >

[VK56VD FOR MEXICO]

## U1001 CAN COMM CIRCUIT

### DTC Logic

INFOID:000000007758216

### DTC DETECTION LOGIC

| DTC No. | Trouble diagnosis name<br>(Trouble diagnosis content) | DTC detecting condition   | Possible cause  |
|---------|---|---|---|
| U1001   | CAN COMM CIRCUIT<br>(CAN communication line)          | When ECM is not transmitting or receiving CAN communication signal other than OBD (emission related diagnosis) for 2 seconds or more. | <ul style="list-style-type: none"><li>Harness or connectors (CAN communication line is open or shorted)</li></ul> |

### DTC CONFIRMATION PROCEDURE

#### 1. PERFORM DTC CONFIRMATION PROCEDURE

- Turn ignition switch ON and wait at least 3 seconds.
- Check 1st trip DTC.

#### Is 1st trip DTC detected?

- YES >> Proceed to [EC-1714, "Diagnosis Procedure"](#).  
NO >> INSPECTION END

### Diagnosis Procedure

INFOID:000000007758217

Perform the trouble diagnosis for CAN communication system. Refer to [LAN-25, "Trouble Diagnosis Flow Chart"](#).

## U1024 CAN COMM CIRCUIT

### DTC Logic

INFOID:000000007758218

#### DTC DETECTION LOGIC

**NOTE:**

If DTC U1024 is displayed with DTC P0607, first perform the trouble diagnosis for DTC P0607. Refer to [EC-1860. "DTC Logic"](#).

| DTC No. | Trouble diagnosis name<br>(Trouble diagnosis content) | DTC detecting condition   | Possible cause  |
|---------|---|---|---|
| U1024   | VVEL CAN COMM CIRCUIT<br>(VVEL CAN communication)     | <ul style="list-style-type: none"> <li>When VVEL control module cannot transmitting or receiving CAN communication signal with ECM for 2 seconds or more.</li> <li>When detecting error during the initial diagnosis of CAN controller of VVEL control module.</li> </ul> | <ul style="list-style-type: none"> <li>Harness or connectors (CAN communication line is open or shorted)</li> <li>ECM</li> <li>VVEL control module</li> </ul> |

#### DTC CONFIRMATION PROCEDURE

### 1. PRECONDITIONING

**TESTING CONDITION:**

**Before performing the following procedure, confirm that battery voltage is 10 V or more at idle.**

>> GO TO 2.

### 2. PERFORM DTC CONFIRMATION PROCEDURE

1. Turn ignition switch ON and wait at least 3 seconds.
2. Check DTC.

Is DTC detected?

- YES >> Proceed to [EC-1715. "Diagnosis Procedure"](#).  
 NO >> INSPECTION END

### Diagnosis Procedure

INFOID:000000007758219

### 1. CHECK VVEL CAN COMMUNICATION CIRCUIT

1. Turn ignition switch OFF.
2. Disconnect ECM harness connector.
3. Disconnect VVEL control module harness connector.
4. Check the continuity between ECM harness connector and VVEL control module harness connector.

| ECM       |          | VVEL control module |          | Continuity |
|-----------|----------|---------------------|----------|------------|
| Connector | Terminal | Connector           | Terminal |            |
| M160      | 161      | E15                 | 24       | Existed    |
|           | 166      |                     | 11       |            |

5. Also check harness for short to ground and short to power.

Is the inspection result normal?

- YES >> GO TO 3.  
 NO >> GO TO 2.

### 2. DETECT MALFUNCTIONING PART

Check the following.

- Harness for open or short between ECM and VVEL control module
- Loose or poor connection for each connector and harness

>> Repair open circuit, short to ground or short to power in harness or connectors.

< DTC/CIRCUIT DIAGNOSIS >

## 3. CHECK INTERMITTENT INCIDENT

Refer to [GI-44, "Intermittent Incident"](#).

Is the inspection result normal?

YES >> GO TO 4.

NO >> Repair or replace.

## 4. REPLACE VVEL CONTROL MODULE

Replace VVEL control module. Refer to [EC-2014, "Removal and Installation"](#).

>> GO TO 5.

## 5. PERFORM DTC CONFIRMATION PROCEDURE

### WITH CONSULT

1. Reconnect all harness connectors disconnected.
2. Turn ignition switch ON.
3. Select "SELF DIAGNOSTIC RESULT" mode with CONSULT.
4. Touch "ERASE".
5. Perform DTC Confirmation Procedure.  
See [EC-1715, "DTC Logic"](#).

### WITH GST

1. Reconnect all harness connectors disconnected.
2. Turn ignition switch ON.
3. Select Service \$04 with GST.
4. Perform DTC Confirmation Procedure.  
See [EC-1715, "DTC Logic"](#).

Is the DTC U1024 displayed again?

YES >> GO TO 6.

NO >> INSPECTION END

## 6. REPLACE ECM

Replace ECM. Refer to [EC-2013, "Removal and Installation"](#).

>> INSPECTION END

P0011, P0021 IVT CONTROL

DTC Logic

INFOID:000000007758223

DTC DETECTION LOGIC

NOTE:

If DTC P0011 or P0021 is displayed with DTC P0075 or P0081, first perform the trouble diagnosis for DTC P0075, P0081. Refer to [EC-1731, "DTC Logic"](#).

| DTC No. | Trouble diagnosis (Trouble diagnosis content)                           | Detecting condition  | Possible cause   |
|---------|---|--|--|
| P0011   | INT/V TIM CONT-B1<br>[Intake valve timing control performance (bank 1)] | There is a gap between angle of target and phase-control angle degree. | <ul style="list-style-type: none"> <li>• Crankshaft position sensor</li> <li>• Camshaft position sensor</li> <li>• Intake valve timing control solenoid valve</li> <li>• Accumulation of debris to the signal pick-up portion of the camshaft</li> <li>• Timing chain installation</li> <li>• Foreign matter caught in the oil groove for intake valve timing control</li> </ul> |
| P0021   | INT/V TIM CONT-B2<br>[Intake valve timing control performance (bank 2)] |  |  |

DTC CONFIRMATION PROCEDURE

1. PRECONDITIONING

1. Turn ignition switch OFF and wait at least 10 seconds.
2. Turn ignition switch ON.
3. Turn ignition switch OFF and wait at least 10 seconds.

TESTING CONDITION:

Before performing the following procedure, confirm that battery voltage is 11 V or more at idle.

>> GO TO 2.

2. PERFORM DTC CONFIRMATION PROCEDURE-I

Ⓜ WITH CONSULT

1. Turn ignition switch ON and select "DATA MONITOR" mode with CONSULT.
2. Start engine and warm it up to the normal operating temperature.
3. Maintain the following conditions for at least 6 consecutive seconds.  
Hold the accelerator pedal as steady as possible.

|                |  |
|----------------|--|
| ENG SPEED      | Less than 2,000 rpm (A constant rotation is maintained.) |
| COOLAN TEMP/S  | More than 70°C (158°F)                                   |
| Selector lever | P or N position  |

4. Let engine idle for 25 seconds.
5. Check 1st trip DTC.

Ⓜ WITH GST

Follow the procedure "With CONSULT" above.

Is 1st trip DTC detected?

YES >> Proceed to [EC-1718, "Diagnosis Procedure"](#)

NO >> GO TO 3.

3. PERFORM DTC CONFIRMATION PROCEDURE-II

Ⓜ WITH CONSULT

1. Select "DATA MONITOR" mode with CONSULT.
2. Maintain the following conditions for at least 20 consecutive seconds.

|               |  |
|---------------|--|
| ENG SPEED     | 1,500 - 3,175 rpm (A constant rotation is maintained.) |
| COOLAN TEMP/S | More than 70°C (158°F)                                 |

# P0011, P0021 IVT CONTROL

[VK56VD FOR MEXICO]

## < DTC/CIRCUIT DIAGNOSIS >

|                         |   |
|-------------------------|---|
| Selector lever          | 1st or 2nd position   |
| Driving location uphill | Driving vehicle uphill<br>(Increased engine load will help maintain the driving conditions required for this test.) |

### CAUTION:

**Always drive at a safe speed.**

3. Check 1st trip DTC.

 WITH GST

Follow the procedure "With CONSULT" above.

Is 1st trip DTC detected?

- YES >> Proceed to [EC-1718, "Diagnosis Procedure"](#).
- NO >> INSPECTION END

## Diagnosis Procedure

INFOID:000000007758224

### 1. CHECK OIL PRESSURE WARNING LAMP

1. Start engine.
2. Check that oil pressure warning lamp is not illuminated.

Is oil pressure warning lamp illuminated?

- YES >> Refer to [LU-23, "Inspection"](#).
- NO >> GO TO 2.

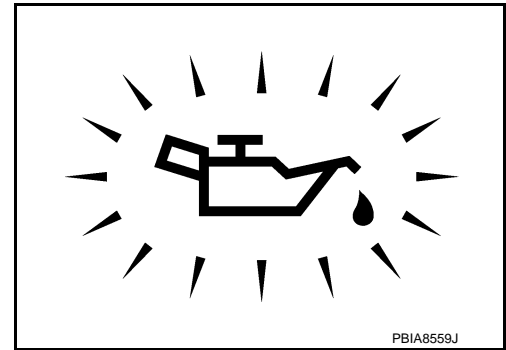

PBIA8559J

### 2. CHECK INTAKE VALVE TIMING CONTROL SOLENOID VALVE

Refer to [EC-1719, "Component Inspection \(Intake Valve Timing Control Solenoid Valve\)"](#).

Is the inspection result normal?

- YES >> GO TO 3.
- NO >> Replace malfunctioning intake valve timing control solenoid valve. Refer to [EM-231, "Exploded View"](#).

### 3. CHECK CRANKSHAFT POSITION SENSOR

Refer to [EC-1826, "Component Inspection \(Crankshaft Position Sensor\)"](#).

Is the inspection result normal?

- YES >> GO TO 4.
- NO >> Replace crankshaft position sensor. Refer to [EM-226, "Exploded View"](#).

### 4. CHECK CAMSHAFT POSITION SENSOR

Refer to [EC-1831, "Component Inspection \(Camshaft Position Sensor\)"](#).

Is the inspection result normal?

- YES >> GO TO 5.
- NO >> Replace malfunctioning camshaft position sensor. Refer to [EM-231, "Exploded View"](#).

### 5. CHECK CAMSHAFT (INTAKE)

Check the following.

# P0011, P0021 IVT CONTROL

[VK56VD FOR MEXICO]

## < DTC/CIRCUIT DIAGNOSIS >

- Accumulation of debris on the signal plate of camshaft front end
- Chipping signal plate of camshaft front end

Is the inspection result normal?

YES >> GO TO 6.

NO >> Remove debris and clean the signal plate of camshaft front end or replace camshaft. Refer to [EM-247, "Disassembly and Assembly"](#).

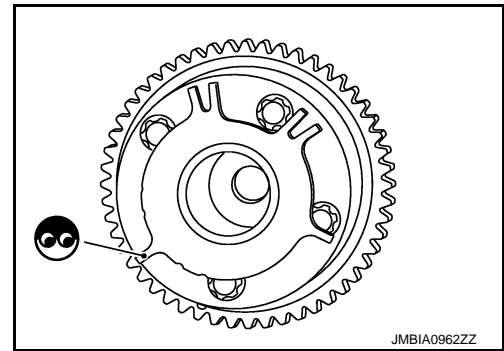

## 6. CHECK TIMING CHAIN INSTALLATION

Check service records for any recent repairs that may cause timing chain misalignment.

Are there any service records that may cause timing chain misalignment?

YES >> Check timing chain installation. Refer to [EM-244, "Inspection"](#).

NO >> GO TO 7.

## 7. CHECK LUBRICATION CIRCUIT

Perform "Inspection of Camshaft Sprocket (INT) Oil Groove". Refer to [EM-255, "Inspection"](#).

Is the inspection result normal?

YES >> GO TO 8.

NO >> Clean lubrication line.

## 8. CHECK INTERMITTENT INCIDENT

Refer to [GI-44, "Intermittent Incident"](#).

>> INSPECTION END

## Component Inspection (Intake Valve Timing Control Solenoid Valve)

INFOID:000000007758225

### 1. CHECK INTAKE VALVE TIMING CONTROL SOLENOID VALVE-I

1. Turn ignition switch OFF.
2. Disconnect intake valve timing control solenoid valve harness connector.
3. Check resistance between intake valve timing control solenoid valve terminals as per the following.

| Terminals         | Resistance                                       |
|-------------------|--|
| 1 and 2           | 7.0 - 7.7 $\Omega$ [at 20°C (68°F)]              |
| 1 or 2 and ground | $\infty \Omega$<br>(Continuity should not exist) |

Is the inspection result normal?

YES >> GO TO 2.

NO >> Replace malfunctioning intake valve timing control solenoid valve. Refer to [EM-231, "Exploded View"](#).

### 2. CHECK INTAKE VALVE TIMING CONTROL SOLENOID VALVE-II

1. Remove intake valve timing control solenoid valve.

## P0011, P0021 IVT CONTROL

[VK56VD FOR MEXICO]

### < DTC/CIRCUIT DIAGNOSIS >

2. Provide 12 V DC between intake valve timing control solenoid valve terminals 1 and 2, and then interrupt it. Check that the plunger moves as shown in the figure.

**CAUTION:**

**Never apply 12 V DC continuously for 5 seconds or more. Doing so may result in damage to the coil in intake valve timing control solenoid valve.**

**NOTE:**

**Always replace O-ring when intake valve timing control solenoid valve is removed.**

Is the inspection result normal?

YES >> INSPECTION END

NO >> Replace malfunctioning intake valve timing control solenoid valve. Refer to [EM-231. "Exploded View"](#).

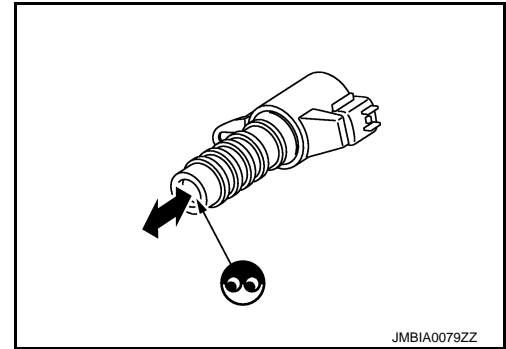



P0014, P0024 EVT CONTROL

DTC Logic

INFOID:000000007758226

DTC DETECTION LOGIC

NOTE:

- If DTC P0014 or P0024 is displayed with DTC P0078, P0084 first perform trouble diagnosis for DTC P0078, P0084. Refer to [EC-1734, "DTC Logic"](#).
- If DTC P0014 or P0024 is displayed with DTC P1078, P1084 first perform trouble diagnosis for DTC P1078, P1084. Refer to [EC-1872, "DTC Logic"](#).

| DTC No. | Trouble diagnosis name<br>(Trouble diagnosis content)                    | Detecting condition  | Possible cause   |
|---------|--|--|--|
| P0014   | EXH/V TIM CONT-B1<br>[Exhaust valve timing control performance (bank 1)] | There is a gap between angle of target and phase-control angle degree. | <ul style="list-style-type: none"> <li>• Crankshaft position sensor</li> <li>• Camshaft position sensor</li> <li>• Exhaust valve timing control position sensor</li> <li>• Exhaust valve timing control solenoid valve</li> <li>• Accumulation of debris to the signal pick-up portion of the camshaft</li> <li>• Timing chain installation</li> <li>• Foreign matter caught in the oil groove for exhaust valve timing control</li> </ul> |
| P0024   | EXH/V TIM CONT-B2<br>[Exhaust valve timing control performance (bank 2)] |  |  |

DTC CONFIRMATION PROCEDURE

1. PRECONDITIONING

1. Turn ignition switch OFF and wait at least 10 seconds.
2. Turn ignition switch ON.
3. Turn ignition switch OFF and wait at least 10 seconds.

TESTING CONDITION:

Before performing the following procedure, confirm that battery voltage is 11 V or more at idle.

>> GO TO 2.

2. PERFORM DTC CONFIRMATION PROCEDURE-I

Ⓜ WITH CONSULT

1. Turn ignition switch ON and select "DATA MONITOR" mode with CONSULT.
2. Start engine and warm it up to the normal operating temperature.
3. Maintain the following conditions for at least 6 consecutive seconds.  
Hold the accelerator pedal as steady as possible.

|                |  |
|----------------|--|
| ENG SPEED      | Less than 2,000 rpm (A constant rotation is maintained.) |
| COOLAN TEMP/S  | More than 70°C (158°F)                                   |
| Selector lever | P or N position  |

4. Let engine idle for 10 seconds.
5. Check 1st trip DTC.

Ⓜ WITH GST

Follow the procedure "With CONSULT" above.

Is 1st trip DTC detected?

- YES >> Proceed to [EC-1722, "Diagnosis Procedure"](#)  
 NO >> GO TO 3.

3. PERFORM DTC CONFIRMATION PROCEDURE-II

Ⓜ WITH CONSULT

1. Select "DATA MONITOR" mode with CONSULT.
2. Maintain the following conditions for at least 20 consecutive seconds.

|                         |   |
|-------------------------|---|
| ENG SPEED               | 1,500 - 3,175 rpm (A constant rotation is maintained.)  |
| COOLAN TEMP/S           | More than 70°C (158°F)  |
| Selector lever          | 1st or 2nd position   |
| Driving location uphill | Driving vehicle uphill<br>(Increased engine load will help maintain the driving conditions required for this test.) |

**CAUTION:**

**Always drive at a safe speed.**

3. Check 1st trip DTC.

 WITH GST

Follow the procedure "With CONSULT" above.

Is 1st trip DTC detected?

YES >> Proceed to [EC-1722. "Diagnosis Procedure"](#)

NO >> INSPECTION END

Diagnosis Procedure

INFOID:000000007758227

**1. CHECK OIL PRESSURE WARNING LAMP**

1. Start engine.

2. Check that oil pressure warning lamp is not illuminated.

Is oil pressure warning lamp illuminated?

YES >> Refer to [LU-23. "Inspection"](#).

NO >> GO TO 2.

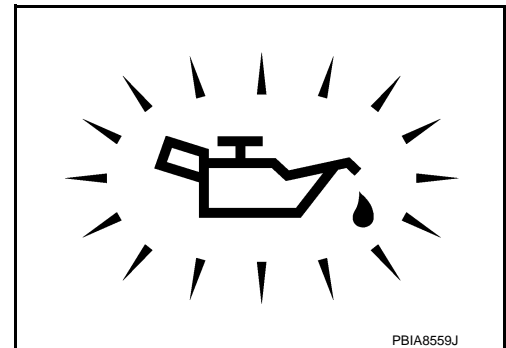

PBJA8559J

**2. CHECK EXHAUST VALVE TIMING CONTROL SOLENOID VALVE**

Refer to [EC-1723. "Component Inspection \(Exhaust Valve Timing Control Solenoid Valve\)"](#).

Is the inspection result normal?

YES >> GO TO 3.

NO >> Replace malfunctioning exhaust valve timing control solenoid valve. Refer to [EM-231. "Exploded View"](#).

**3. CHECK EXHAUST VALVE TIMING CONTROL POSITION SENSOR**

Refer to [EC-1874. "Component Inspection \(Exhaust Valve Timing Control Position Sensor\)"](#).

Is the inspection result normal?

YES >> GO TO 4.

NO >> Replace malfunctioning exhaust valve timing control position sensor.

**4. CHECK CRANKSHAFT POSITION SENSOR**

Refer to [EC-1826. "Component Inspection \(Crankshaft Position Sensor\)"](#).

Is the inspection result normal?

YES >> GO TO 5.

NO >> Replace crankshaft position sensor. Refer to [EM-226. "Exploded View"](#).

**5. CHECK CAMSHAFT POSITION SENSOR**

Refer to [EC-1831. "Component Inspection \(Camshaft Position Sensor\)"](#).

Is the inspection result normal?

YES >> GO TO 6.

NO >> Replace malfunctioning camshaft position sensor. Refer to [EM-231. "Exploded View"](#).

< DTC/CIRCUIT DIAGNOSIS >

**6.CHECK CAMSHAFT (EXH)**

Check the following.

- Accumulation of debris to the signal plate of camshaft front end
- Chipping signal plate of camshaft front end

Is the inspection result normal?

YES >> GO TO 7.

NO >> Remove debris and clean the signal plate of camshaft front end or replace camshaft. Refer to [EM-247. "Disassembly and Assembly"](#).

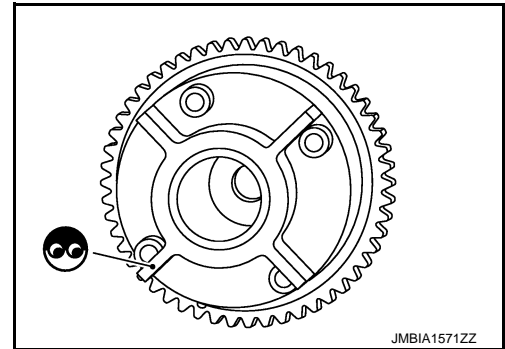

**7.CHECK TIMING CHAIN INSTALLATION**

Check service records for any recent repairs that may cause timing chain misaligned.

Are there any service records that may cause timing chain misaligned?

YES >> Check timing chain installation. Refer to [EM-244. "Inspection"](#).

NO >> GO TO 8.

**8.CHECK LUBRICATION CIRCUIT**

Perform "Inspection of Camshaft Sprocket (EXT) Oil Groove". Refer to [EM-255. "Inspection"](#).

Is the inspection result normal?

YES >> GO TO 9.

NO >> Clean lubrication line.

**9.CHECK INTERMITTENT INCIDENT**

Refer to [GI-44. "Intermittent Incident"](#).

>> INSPECTION END

**Component Inspection (Echaust Valve Timing Control Solenoid Valve)**

INFOID:000000007758228

**1.CHECK EXHAUST VALVE TIMING CONTROL SOLENOID VALVE-I**

1. Turn ignition switch OFF.
2. Disconnect exhaust valve timing control solenoid valve harness connector.
3. Check resistance between exhaust valve timing control solenoid valve terminals as per the following.

| Terminals         | Resistance                                       |
|-------------------|--|
| 1 and 2           | 7.0 - 7.7 $\Omega$ [at 20°C (68°F)]              |
| 1 or 2 and ground | $\infty \Omega$<br>(Continuity should not exist) |

Is the inspection result normal?

YES >> GO TO 2.

NO >> Replace malfunctioning exhaust valve timing control solenoid valve.

**2.CHECK EXHAUST VALVE TIMING CONTROL SOLENOID VALVE-II**

1. Remove exhaust valve timing control solenoid valve.

## P0014, P0024 EVT CONTROL

[VK56VD FOR MEXICO]

### < DTC/CIRCUIT DIAGNOSIS >

2. Provide 12 V DC between exhaust valve timing control solenoid valve terminals 1 and 2, and then interrupt it. Check that the plunger moves as shown in the figure.

**CAUTION:**

**Do not apply 12 V DC continuously for 5 seconds or more. Doing so may result in damage to the coil in exhaust valve timing control solenoid valve.**

**NOTE:**

**Always replace O-ring when exhaust valve timing control solenoid valve is removed.**

Is the inspection result normal?

YES >> INSPECTION END

NO >> Replace malfunctioning exhaust valve timing control solenoid valve.

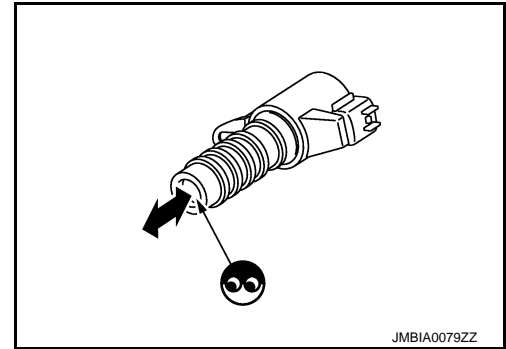

# P0031, P0032, P0051, P0052 A/F SENSOR 1 HEATER

< DTC/CIRCUIT DIAGNOSIS >

[VK56VD FOR MEXICO]

## P0031, P0032, P0051, P0052 A/F SENSOR 1 HEATER

### DTC Logic

INFOID:000000007758229

### DTC DETECTION LOGIC

| DTC No. | Trouble diagnosis<br>(Trouble diagnosis content)                         | DTC detecting condition   | Possible cause   |
|---------|--|---|--|
| P0031   | A/F SEN1 HTR (B1)<br>[A/F sensor 1 heater (bank 1) control circuit low]  | The current amperage in the A/F sensor 1 heater circuit is out of the normal range.<br>(An excessively low voltage signal is sent to ECM through the A/F sensor 1 heater.)  | <ul style="list-style-type: none"> <li>Harness or connectors (The A/F sensor 1 heater circuit is open or shorted.)</li> <li>A/F sensor 1 heater</li> </ul> |
| P0032   | A/F SEN1 HTR (B1)<br>[A/F sensor 1 heater (bank 1) control circuit high] | The current amperage in the A/F sensor 1 heater circuit is out of the normal range.<br>(An excessively high voltage signal is sent to ECM through the A/F sensor 1 heater.) | <ul style="list-style-type: none"> <li>Harness or connectors (The A/F sensor 1 heater circuit is shorted.)</li> <li>A/F sensor 1 heater</li> </ul>         |
| P0051   | A/F SEN1 HTR (B2)<br>[A/F sensor 1 heater (bank 2) control circuit low]  | The current amperage in the A/F sensor 1 heater circuit is out of the normal range.<br>(An excessively low voltage signal is sent to ECM through the A/F sensor 1 heater.)  | <ul style="list-style-type: none"> <li>Harness or connectors (The A/F sensor 1 heater circuit is open or shorted.)</li> <li>A/F sensor 1 heater</li> </ul> |
| P0052   | A/F SEN1 HTR (B2)<br>[A/F sensor 1 heater (bank 2) control circuit high] | The current amperage in the A/F sensor 1 heater circuit is out of the normal range.<br>(An excessively high voltage signal is sent to ECM through the A/F sensor 1 heater.) | <ul style="list-style-type: none"> <li>Harness or connectors (The A/F sensor 1 heater circuit is shorted.)</li> <li>A/F sensor 1 heater</li> </ul>         |

### DTC CONFIRMATION PROCEDURE

#### 1. PRECONDITIONING

- Turn ignition switch OFF and wait at least 10 seconds.
- Turn ignition switch ON.
- Turn ignition switch OFF and wait at least 10 seconds.

#### TESTING CONDITION:

Before performing the following procedure, confirm that battery voltage is 11 V or more at idle.

>> GO TO 2.

#### 2. PERFORM DTC CONFIRMATION PROCEDURE

- Start engine and let it idle for at least 10 seconds.
- Check 1st trip DTC.

Is 1st trip DTC detected?

- YES >> Proceed to [EC-1725, "Diagnosis Procedure"](#).  
 NG >> INSPECTION END

### Diagnosis Procedure

INFOID:000000007758230

#### 1. CHECK AIR FUEL RATIO (A/F) SENSOR 1 POWER SUPPLY CIRCUIT

- Disconnect air fuel ratio (A/F) sensor 1 harness connector.
- Turn ignition switch ON.
- Check the voltage between A/F sensor 1 harness connector and ground.

| DTC          | A/F sensor 1 |           |          | Ground | Voltage         |
|--------------|--------------|-----------|----------|--------|-----------------|
|              | Bank         | Connector | Terminal |        |                 |
| P0031, P0032 | 1            | F23       | 4        | Ground | Battery voltage |
| P0051, P0052 | 2            | F24       | 4        |        |                 |

Is the inspection result normal?

- YES >> GO TO 3.  
 NO >> GO TO 2.

# P0031, P0032, P0051, P0052 A/F SENSOR 1 HEATER

[VK56VD FOR MEXICO]

< DTC/CIRCUIT DIAGNOSIS >

## 2. DETECT MALFUNCTIONING PART

Check the following.

- 15 A fuse (No. 45)
- Harness for open or short between A/F sensor 1 and fuse
- Loose or poor connection for each connector and harness

>> Repair or replace harness or connectors.

## 3. CHECK A/F SENSOR 1 HEATER OUTPUT SIGNAL CIRCUIT FOR OPEN AND SHORT

1. Turn ignition switch OFF.
2. Disconnect ECM harness connector.
3. Check the continuity between A/F sensor 1 harness connector and ECM harness connector.

| DTC          | A/F sensor 1 |           |          | ECM       |          | Continuity |
|--------------|--------------|-----------|----------|-----------|----------|------------|
|              | Bank         | Connector | Terminal | Connector | Terminal |            |
| P0031, P0032 | 1            | F23       | 2        | F110      | 48       | Existed    |
| P0051, P0052 | 2            | F24       | 2        |           | 53       |            |

4. Also check harness for short to ground and short to power.

Is the inspection result normal?

YES >> GO TO 4.

NO >> Repair open circuit, short to ground or short to power in harness or connectors.

## 4. CHECK A/F SENSOR 1 HEATER

Refer to [EC-1726, "Component Inspection \(A/F Sensor 1 Heater\)"](#).

Is the inspection result normal?

YES >> GO TO 6.

NO >> GO TO 5.

## 5. REPLACE A/F SENSOR 1

Replace malfunctioning A/F sensor 1. Refer to [EM-223, "Exploded View"](#).

### CAUTION:

- Discard any A/F sensor which has been dropped from a height of more than 0.5 m (19.7 in) onto a hard surface such as a concrete floor; use a new one.
- Before installing new A/F sensor, clean exhaust system threads using Oxygen Sensor Thread Cleaner [commercial service tool (J-43897-18 or J-43897-12)] and approved anti-seize lubricant (commercial service tool).

>> INSPECTION END

## 6. CHECK INTERMITTENT INCIDENT

Perform [GI-44, "Intermittent Incident"](#).

>> INSPECTION END

## Component Inspection (A/F Sensor 1 Heater)

INFOID:000000007758231

### 1. CHECK AIR FUEL RATIO (A/F) SENSOR 1

1. Turn ignition switch OFF.
2. Disconnect air fuel ratio (A/F) sensor 1 harness connector.
3. Check resistance between A/F sensor 1 terminals as per the following.

| Terminal | Resistance                            |
|----------|---------------------------------------|
| 2 and 5  | 1.98 - 2.66 $\Omega$ [at 25°C (77°F)] |

# P0031, P0032, P0051, P0052 A/F SENSOR 1 HEATER

< DTC/CIRCUIT DIAGNOSIS >

[VK56VD FOR MEXICO]

| Terminal      | Resistance                    |
|---------------|-------------------------------|
| 2 and 3, 4, 6 | $\infty \Omega$               |
| 5 and 3, 4, 6 | (Continuity should not exist) |

Is the inspection result normal?

YES >> INSPECTION END

NO >> GO TO 2.

## 2.REPLACE A/F SENSOR 1

Replace malfunctioning A/F sensor 1.

### CAUTION:

- Discard any A/F sensor which has been dropped from a height of more than 0.5 m (19.7 in) onto a hard surface such as a concrete floor; use a new one.
- Before installing new A/F sensor, clean exhaust system threads using Oxygen Sensor Thread Cleaner [commercial service tool (J-43897-18 or J-43897-12)] and approved anti-seize lubricant (commercial service tool).

>> INSPECTION END

A

EC

C

D

E

F

G

H

I

J

K

L

M

N

O

P

# P0037, P0038, P0057, P0058 HO2S2 HEATER

< DTC/CIRCUIT DIAGNOSIS >

[VK56VD FOR MEXICO]

## P0037, P0038, P0057, P0058 HO2S2 HEATER

### DTC Logic

INFOID:000000007758232

### DTC DETECTION LOGIC

| DTC No. | Trouble diagnosis name<br>(Trouble diagnosis content)                           | DTC detecting condition   | Possible cause  |
|---------|---|---|---|
| P0037   | HO2S2 HTR (B1)<br>[Heated oxygen sensor 2 heater (bank 1) control circuit low]  | The current amperage in the heated oxygen sensor 2 heater circuit is out of the normal range.<br>(An excessively low voltage signal is sent to ECM through the heated oxygen sensor 2 heater.)  | <ul style="list-style-type: none"><li>• Harness or connectors<br/>(The heated oxygen sensor 2 heater circuit is open or shorted.)</li><li>• Heated oxygen sensor 2 heater</li></ul> |
| P0038   | HO2S2 HTR (B1)<br>[Heated oxygen sensor 2 heater (bank 1) control circuit high] | The current amperage in the heated oxygen sensor 2 heater circuit is out of the normal range.<br>(An excessively high voltage signal is sent to ECM through the heated oxygen sensor 2 heater.) | <ul style="list-style-type: none"><li>• Harness or connectors<br/>(The heated oxygen sensor 2 heater circuit is shorted.)</li><li>• Heated oxygen sensor 2 heater</li></ul>         |
| P0057   | HO2S2 HTR (B2)<br>[Heated oxygen sensor 2 heater (bank 2) control circuit low]  | The current amperage in the heated oxygen sensor 2 heater circuit is out of the normal range.<br>(An excessively low voltage signal is sent to ECM through the heated oxygen sensor 2 heater.)  | <ul style="list-style-type: none"><li>• Harness or connectors<br/>(The heated oxygen sensor 2 heater circuit is open or shorted.)</li><li>• Heated oxygen sensor 2 heater</li></ul> |
| P0058   | HO2S2 HTR (B2)<br>[Heated oxygen sensor 2 heater (bank 2) control circuit high] | The current amperage in the heated oxygen sensor 2 heater circuit is out of the normal range.<br>(An excessively high voltage signal is sent to ECM through the heated oxygen sensor 2 heater.) | <ul style="list-style-type: none"><li>• Harness or connectors<br/>(The heated oxygen sensor 2 heater circuit is shorted.)</li><li>• Heated oxygen sensor 2 heater</li></ul>         |

### DTC CONFIRMATION PROCEDURE

#### 1. PRECONDITIONING

1. Turn ignition switch OFF and wait at least 10 seconds.
2. Turn ignition switch ON.
3. Turn ignition switch OFF and wait at least 10 seconds.

#### TESTING CONDITION:

Before performing the following procedure, confirm that battery voltage is 11 V or more at idle.

>> GO TO 2.

#### 2. PERFORM DTC CONFIRMATION PROCEDURE

1. Start engine and warm it up to the normal operating temperature.
2. Turn ignition switch OFF and wait at least 10 seconds.
3. Turn ignition switch ON.
4. Turn ignition switch OFF and wait at least 10 seconds.
5. Start engine and keep the engine speed between 3,500 and 4,000 rpm for at least 1 minute under no load.
6. Let engine idle for 1 minute.
7. Check 1st trip DTC.

Is 1st trip DTC detected?

- YES >> Proceed to [EC-1728, "Diagnosis Procedure"](#).  
NO >> INSPECTION END

### Diagnosis Procedure

INFOID:000000007758233

#### 1. CHECK HEATED OXYGEN SENSOR 2 (HO2S2) POWER SUPPLY CIRCUIT

1. Disconnect heated oxygen sensor 2 (HO2S2) harness connector.
2. Turn ignition switch ON.
3. Check the voltage between HO2S2 harness connector and ground.



# P0037, P0038, P0057, P0058 HO2S2 HEATER

< DTC/CIRCUIT DIAGNOSIS >

[VK56VD FOR MEXICO]

| DTC          | HO2S2 |           |          | Ground | Voltage         |
|--------------|-------|-----------|----------|--------|-----------------|
|              | Bank  | Connector | Terminal |        |                 |
| P0037, P0038 | 1     | F87       | 2        | Ground | Battery voltage |
| P0057, P0058 | 2     | F88       | 2        |        |                 |

Is the inspection result normal?

- YES >> GO TO 3.
- NO >> GO TO 2.

## 2. DETECT MALFUNCTIONING PART

Check the following.

- 15 A fuse (No. 45)
- Harness for open or short between heated oxygen sensor 2 and fuse
- Loose or poor connection for each connector and harness

>> Repair open circuit, short to ground or short to power in harness or connectors.

## 3. CHECK HO2S2 OUTPUT SIGNAL CIRCUIT FOR OPEN AND SHORT

1. Turn ignition switch OFF.
2. Disconnect ECM harness connector.
3. Check the continuity between HO2S2 harness connector and ECM harness connector.

| DTC          | HO2S2 |           |          | ECM       |          | Continuity |
|--------------|-------|-----------|----------|-----------|----------|------------|
|              | Bank  | Connector | Terminal | Connector | Terminal |            |
| P0037, P0038 | 1     | F87       | 3        | F110      | 47       | Existed    |
| P0057, P0058 | 2     | F88       | 3        |           | 52       |            |

4. Also check harness for short to ground and short to power.

Is the inspection result normal?

- YES >> GO TO 4.
- NO >> Repair open circuit, short to ground or short to power in harness or connectors.

## 4. CHECK HO2S2 HEATER

Refer to [EC-1730. "Component Inspection \(HO2 Sensor 2 Heater\)".](#)

Is the inspection result normal?

- YES >> GO TO 6.
- NO >> GO TO 5.

## 5. REPLACE HEATED OXYGEN SENSOR 2

Replace malfunctioning heated oxygen sensor 2. Refer to [EM-223. "Exploded View".](#)

### CAUTION:

- Discard any heated oxygen sensor which has been dropped from a height of more than 0.5 m (19.7 in) onto a hard surface such as a concrete floor; use a new one.
- Before installing new oxygen sensor, clean exhaust system threads using Oxygen Sensor Thread Cleaner [commercial service tool (J-43897-18 or J-43897-12)] and approved anti-seize lubricant (commercial service tool).

>> INSPECTION END

## 6. CHECK INTERMITTENT INCIDENT

Refer to [GI-44. "Intermittent Incident".](#)

>> INSPECTION END

# P0037, P0038, P0057, P0058 HO2S2 HEATER

< DTC/CIRCUIT DIAGNOSIS >

[VK56VD FOR MEXICO]

## Component Inspection (HO2 Sensor 2 Heater)

INFOID:000000007758234

### 1. CHECK HEATED OXYGEN SENSOR 2 HEATER

1. Turn ignition switch OFF.
2. Disconnect heated oxygen sensor 2 (HO2S2) harness connector.
3. Check resistance between HO2S2 terminals as follows.

| Terminal   | Resistance                          |
|------------|-------------------------------------|
| 2 and 3    | 3.4 - 4.4 $\Omega$ [at 25°C (77°F)] |
| 2 and 1, 4 | $\infty \Omega$                     |
| 3 and 1, 4 | (Continuity should not exist)       |

Is the inspection result normal?

- YES >> INSPECTION END  
NO >> GO TO 2.

### 2. REPLACE HEATED OXYGEN SENSOR 2

Replace malfunctioning heated oxygen sensor 2.

**CAUTION:**

- Discard any heated oxygen sensor which has been dropped from a height of more than 0.5 m (19.7 in) onto a hard surface such as a concrete floor; use a new one.
- Before installing new oxygen sensor, clean exhaust system threads using Oxygen Sensor Thread Cleaner [commercial service tool (J-43897-18 or J-43897-12)] and approved anti-seize lubricant (commercial service tool).

>> INSPECTION END

# P0075, P0081 IVT CONTROL SOLENOID VALVE

< DTC/CIRCUIT DIAGNOSIS >

[VK56VD FOR MEXICO]

## P0075, P0081 IVT CONTROL SOLENOID VALVE

### DTC Logic

INFOID:000000007758235

### DTC DETECTION LOGIC

| DTC No. | Trouble diagnosis name<br>(Trouble diagnosis content)                               | DTC detecting condition  | Possible cause   |
|---------|---|--|--|
| P0075   | INT/V TIM V/CIR-B1<br>[Intake valve timing control solenoid valve (bank 1) circuit] | An improper voltage is sent to the ECM through intake valve timing control solenoid valve. | <ul style="list-style-type: none"> <li>Harness or connectors (Intake valve timing control solenoid valve circuit is open or shorted.)</li> <li>Intake valve timing control solenoid valve</li> </ul> |
| P0081   | INT/V TIM V/CIR-B2<br>[Intake valve timing control solenoid valve (bank 2) circuit] |  |  |

### DTC CONFIRMATION PROCEDURE

#### 1. PRECONDITIONING

If DTC Confirmation Procedure has been previously conducted, always perform the following procedure before conducting the next test.

1. Turn ignition switch OFF and wait at least 10 seconds.
2. Turn ignition switch ON.
3. Turn ignition switch OFF and wait at least 10 seconds.

>> GO TO 2.

#### 2. PERFORM DTC CONFIRMATION PROCEDURE

1. Start engine and let it idle for 5 seconds.
2. Check 1st trip DTC.

Is 1st trip DTC detected?

- YES >> Proceed to [EC-1731. "Diagnosis Procedure"](#).  
 NO >> INSPECTION END

### Diagnosis Procedure

INFOID:000000007758236

#### 1. CHECK INTAKE VALVE TIMING CONTROL SOLENOID VALVE POWER SUPPLY CIRCUIT

1. Turn ignition switch OFF.
2. Disconnect intake valve timing (IVT) control solenoid valve harness connector.
3. Turn ignition switch ON.
4. Check the voltage between IVT control solenoid valve harness connector and ground.

| DTC   | IVT control solenoid valve |           |          | Ground | Voltage         |
|-------|----------------------------|-----------|----------|--------|-----------------|
|       | Bank                       | Connector | Terminal |        |                 |
| P0075 | 1                          | F22       | 2        | Ground | Battery voltage |
| P0081 | 2                          | F21       | 2        |        |                 |

Is the inspection result normal?

- YES >> GO TO 3.  
 NO >> GO TO 2.

#### 2. DETECT MALFUNCTIONING PART

Check the following.

- Harness for open or short between IVT control solenoid valve and IPDM E/R
- Loose or poor connection for each connector and harness

>> Repair open circuit, short to ground or short to power in harness or connectors.

# P0075, P0081 IVT CONTROL SOLENOID VALVE

< DTC/CIRCUIT DIAGNOSIS >

[VK56VD FOR MEXICO]

## 3. CHECK IVT CONTROL SOLENOID VALVE OUTPUT SIGNAL CIRCUIT FOR OPEN AND SHORT

1. Turn ignition switch OFF.
2. Disconnect ECM harness connector.
3. Check the continuity between IVT control solenoid valve harness connector and ECM harness connector.

| DTC   | IVT control solenoid valve |           |          | ECM       |          | Continuity |
|-------|----------------------------|-----------|----------|-----------|----------|------------|
|       | Bank                       | Connector | Terminal | Connector | Terminal |            |
| P0075 | 1                          | F22       | 1        | F110      | 54       | Existed    |
| P0081 | 2                          | F21       | 1        |           | 49       |            |

4. Also check harness for short to ground and short to power.

Is the inspection result normal?

YES >> GO TO 4.

NO >> Repair open circuit, short to ground or short to power in harness or connectors.

## 4. CHECK IVT CONTROL SOLENOID VALVE

Refer to [EC-1732, "Component Inspection \(Intake Valve Timing Control Solenoid Valve\)"](#).

Is the inspection result normal?

YES >> GO TO 5.

NO >> Replace malfunctioning IVT control solenoid valve.

## 5. CHECK INTERMITTENT INCIDENT

Refer to [GI-44, "Intermittent Incident"](#).

>> INSPECTION END

## Component Inspection (Intake Valve Timing Control Solenoid Valve)

INFOID:000000007758237

### 1. CHECK INTAKE VALVE TIMING CONTROL SOLENOID VALVE-I

1. Turn ignition switch OFF.
2. Disconnect intake valve timing control solenoid valve harness connector.
3. Check resistance between intake valve timing control solenoid valve terminals as per the following.

| Terminals         | Resistance                                       |
|-------------------|--|
| 1 and 2           | 7.0 - 7.7 $\Omega$ [at 20°C (68°F)]              |
| 1 or 2 and ground | $\infty \Omega$<br>(Continuity should not exist) |

Is the inspection result normal?

YES >> GO TO 2.

NO >> Replace malfunctioning intake valve timing control solenoid valve. Refer to [EM-231, "Exploded View"](#).

### 2. CHECK INTAKE VALVE TIMING CONTROL SOLENOID VALVE-II

1. Remove intake valve timing control solenoid valve.
2. Provide 12 V DC between intake valve timing control solenoid valve terminals 1 and 2, and then interrupt it. Check that the plunger moves as shown in the figure.

**CAUTION:**

Never apply 12 V DC continuously for 5 seconds or more. Doing so may result in damage to the coil in intake valve timing control solenoid valve.

**NOTE:**

Always replace O-ring when intake valve timing control solenoid valve is removed.

Is the inspection result normal?

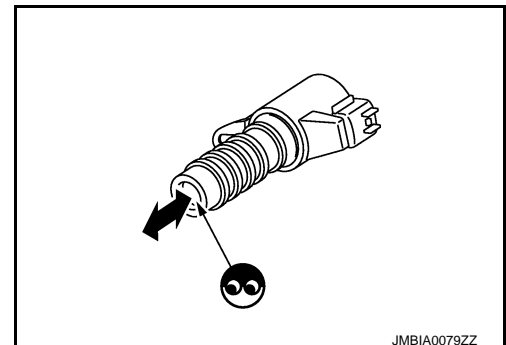

# P0075, P0081 IVT CONTROL SOLENOID VALVE

< DTC/CIRCUIT DIAGNOSIS >

[VK56VD FOR MEXICO]

YES >> INSPECTION END

NO >> Replace malfunctioning intake valve timing control solenoid valve. Refer to [EM-231, "Exploded View"](#).

A

EC

C

D

E

F

G

H

I

J

K

L

M

N

O

P

# P0078, P0084 EVT CONTROL SOLENOID VALVE

< DTC/CIRCUIT DIAGNOSIS >

[VK56VD FOR MEXICO]

## P0078, P0084 EVT CONTROL SOLENOID VALVE

### DTC Logic

INFOID:000000007758238

### DTC DETECTION LOGIC

| DTC No. | Trouble diagnosis name<br>(Trouble diagnosis content)                                | DTC detecting condition   | Possible cause  |
|---------|--|---|---|
| P0078   | EX V/T ACT/CIRC-B1<br>[Exhaust valve timing control solenoid valve (bank 1) circuit] | An improper voltage is sent to the ECM through exhaust valve timing control solenoid valve. | <ul style="list-style-type: none"><li>• Harness or connectors (Exhaust valve timing control solenoid valve circuit is open or shorted.)</li><li>• Exhaust valve timing control solenoid valve</li></ul> |
| P0084   | EX V/T ACT/CIRC-B2<br>[Exhaust valve timing control solenoid valve (bank 2) circuit] |   |   |

### DTC CONFIRMATION PROCEDURE

#### 1. PRECONDITIONING

If DTC Confirmation Procedure has been previously conducted, always perform the following procedure before conducting the next test.

1. Turn ignition switch OFF and wait at least 10 seconds.
2. Turn ignition switch ON.
3. Turn ignition switch OFF and wait at least 10 seconds.

>> GO TO 2.

#### 2. PERFORM DTC CONFIRMATION PROCEDURE

1. Start engine and let it idle for 5 seconds.
2. Check 1st trip DTC.

Is 1st trip DTC detected?

- YES >> Proceed to [EC-1734, "Diagnosis Procedure"](#).  
NO >> INSPECTION END

### Diagnosis Procedure

INFOID:000000007758239

#### 1. CHECK EXHAUST VALVE TIMING CONTROL SOLENOID VALVE POWER SUPPLY CIRCUIT

1. Turn ignition switch OFF.
2. Disconnect exhaust valve timing (EVT) control solenoid valve harness connector.
3. Turn ignition switch ON.
4. Check the voltage between EVT control solenoid valve harness connector and ground.

| DTC   | EVT control solenoid valve |           |          | Ground | Voltage         |
|-------|----------------------------|-----------|----------|--------|-----------------|
|       | Bank                       | Connector | Terminal |        |                 |
| P0078 | 1                          | F26       | 2        | Ground | Battery voltage |
| P0084 | 2                          | F25       | 2        |        |                 |

Is the inspection result normal?

- YES >> GO TO 3.  
NO >> GO TO 2.

#### 2. DETECT MALFUNCTIONING PART

Check the following.

- Harness for open or short between EVT control solenoid valve and IPDM E/R
- Loose or poor connection for each connector and harness

>> Repair open circuit, short to ground or short to power in harness or connectors.

# P0078, P0084 EVT CONTROL SOLENOID VALVE

< DTC/CIRCUIT DIAGNOSIS >

[VK56VD FOR MEXICO]

## 3. CHECK EVT CONTROL SOLENOID VALVE OUTPUT SIGNAL CIRCUIT FOR OPEN AND SHORT

1. Turn ignition switch OFF.
2. Disconnect ECM harness connector.
3. Check the continuity between EVT control solenoid valve harness connector and ECM harness connector.

| DTC   | EVT control solenoid valve |           |          | ECM       |          | Continuity |
|-------|----------------------------|-----------|----------|-----------|----------|------------|
|       | Bank                       | Connector | Terminal | Connector | Terminal |            |
| P0078 | 1                          | F26       | 1        | F110      | 55       | Existed    |
| P0084 | 2                          | F25       | 1        |           | 50       |            |

4. Also check harness for short to ground and short to power.

Is the inspection result normal?

YES >> GO TO 4.

NO >> Repair open circuit, short to ground or short to power in harness or connectors.

## 4. CHECK EVT CONTROL SOLENOID VALVE

Refer to [EC-1723, "Component Inspection \(Echaust Valve Timing Control Solenoid Valve\)"](#).

Is the inspection result normal?

YES >> GO TO 5.

NO >> Replace malfunctioning EVT control solenoid valve. Refer to [EM-231, "Exploded View"](#).

## 5. CHECK INTERMITTENT INCIDENT

Refer to [GI-44, "Intermittent Incident"](#).

>> INSPECTION END

## Component Inspection (Echaust Valve Timing Control Solenoid Valve)

INFOID:000000007758240

### 1. CHECK EXHAUST VALVE TIMING CONTROL SOLENOID VALVE-I

1. Turn ignition switch OFF.
2. Disconnect exhaust valve timing control solenoid valve harness connector.
3. Check resistance between exhaust valve timing control solenoid valve terminals as per the following.

| Terminals         | Resistance                                       |
|-------------------|--|
| 1 and 2           | 7.0 - 7.7 $\Omega$ [at 20°C (68°F)]              |
| 1 or 2 and ground | $\infty \Omega$<br>(Continuity should not exist) |

Is the inspection result normal?

YES >> GO TO 2.

NO >> Replace malfunctioning exhaust valve timing control solenoid valve.

### 2. CHECK EXHAUST VALVE TIMING CONTROL SOLENOID VALVE-II

1. Remove exhaust valve timing control solenoid valve.
2. Provide 12 V DC between exhaust valve timing control solenoid valve terminals 1 and 2, and then interrupt it. Check that the plunger moves as shown in the figure.

**CAUTION:**

**Do not apply 12 V DC continuously for 5 seconds or more. Doing so may result in damage to the coil in exhaust valve timing control solenoid valve.**

**NOTE:**

**Always replace O-ring when exhaust valve timing control solenoid valve is removed.**

Is the inspection result normal?

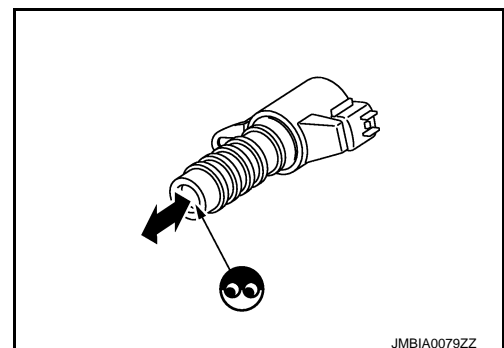

## P0078, P0084 EVT CONTROL SOLENOID VALVE

< DTC/CIRCUIT DIAGNOSIS >

[VK56VD FOR MEXICO]

---

YES >> INSPECTION END

NO >> Replace malfunctioning exhaust valve timing control solenoid valve.



# P008A LOW FUEL PRESSURE CONTROL SYSTEM

< DTC/CIRCUIT DIAGNOSIS >

[VK56VD FOR MEXICO]

## P008A LOW FUEL PRESSURE CONTROL SYSTEM

### DTC Logic

INFOID:000000007758241

### DTC DETECTION LOGIC

#### NOTE:

If DTC P008A is displayed with DTC P1197, first perform the trouble diagnosis for DTC P1197. Refer to [EC-1885, "DTC Logic"](#).

| DTC No. | Trouble diagnosis name    | DTC detecting condition  | Possible cause  |
|---------|---------------------------|--|---|
| P008A   | Low fuel pressure too low | A condition of low fuel pressure 0.23 MPa (2.3 bar, 2.346 kg/cm <sup>2</sup> , 33.35 psi) or less continues for 5 seconds or more after warming up the engine. | <ul style="list-style-type: none"><li>• Harness or connectors (The low pressure fuel pump circuit is open or shorted.)</li><li>• Low pressure fuel pump</li><li>• Fuel pressure regulator</li><li>• Low pressure fuel system</li><li>• Out of gas</li></ul> |

### DTC CONFIRMATION PROCEDURE

#### 1. PRECONDITIONING

1. Turn ignition switch OFF and wait at least 10 seconds.
2. Turn ignition switch ON.
3. Turn ignition switch OFF and wait at least 10 seconds.

#### TESTING CONDITION:

Before performing the following procedure, confirm that battery voltage is 11 V or more at idle.

>> GO TO 2.

#### 2. PERFORM DTC CONFIRMATION PROCEDURE

1. Check that the fuel tank is 1/8 full of fuel.
2. Start the engine and warm it up to the normal operating temperature.

#### NOTE:

When replacing ECM, warm up the engine until "COOLAN TEMP/S" on "DATA MONITOR" of CONSULT reaches at least 70°C (158°F).

3. Let the engine at idle for 60 seconds.
4. Check 1st trip DTC.

Is 1st trip DTC detected?

- YES >> Proceed to [EC-1737, "Diagnosis Procedure"](#).  
NO >> INSPECTION END

### Diagnosis Procedure

INFOID:000000007758242

#### 1. PERFORM LOW PRESSURE FUEL PUMP COMPONENT FUNCTION CHECK

Refer to [EC-1989, "Component Function Check"](#).

Is the inspection result normal?

- YES >> GO TO 2.  
NO >> Perform low pressure fuel pump diagnosis. Refer to [EC-1989, "Diagnosis Procedure"](#).

#### 2. CHECK FUEL LEAKAGE

1. Start the engine.
2. Visually check that the low fuel pressure system has no fuel leakage.

Is inspection result normal?

- YES >> GO TO 3.  
NO >> Repair or replace error-detected parts.

#### 3. CHECK LOW PRESSURE FUEL PIPING AND HOSE

1. Turn ignition switch OFF.

## P008A LOW FUEL PRESSURE CONTROL SYSTEM

< DTC/CIRCUIT DIAGNOSIS >

[VK56VD FOR MEXICO]

2. Check that the low pressure fuel piping and hose have no breakage, bend, and crush. Refer to [FL-4, "Inspection"](#).

Is inspection result normal?

- YES >> Replace fuel level sensor unit and fuel pump (main) (fuel pressure regulator malfunction). Refer to [FL-6, "Removal and Installation"](#).
- NO >> Repair or replace error-detected parts.

P0087 FRP CONTROL SYSTEM

DTC Logic

INFOID:000000007785165

DTC DETECTION LOGIC

NOTE:

- If DTC P0087 is displayed with DTC P0090 and/or P1197, first perform the trouble diagnosis for DTC P0090 and/or P1197.
- DTC P0087 may be displayed when running out of gas or air accumulation.

| DTC No. | Trouble diagnosis name<br>(Trouble diagnosis content) | DTC detecting condition   | Possible cause   |
|---------|---|---|--|
| P0087   | LOW FUEL PRES<br>(High fuel pressure too low)         | <ul style="list-style-type: none"> <li>• Fuel rail pressure does not reach 1.3 MPa (13 bar, 13.3 kg/cm<sup>2</sup>, 188.5 psi) at engine cold start [water temperature 5°C (41°F) – 40°C (104°F)].</li> <li>• Fuel rail pressure remains at 8.5 MPa (85 bar, 86.7 kg/cm<sup>2</sup>, 1232.8 psi) or less for 1 second or more during engine idle condition after cold start [water temperature 5°C (41°F) – 40°C (104°F)].</li> <li>• The following condition continues for 5 seconds or more after engine start (regardless of water temperature):<br/>Target fuel pressure – Actual fuel pressure ≥ 2.7 MPa (27 bar, 27.5 kg/cm<sup>2</sup>, 392 psi).</li> </ul> | <ul style="list-style-type: none"> <li>• Fuel system</li> <li>• Leakage in fuel line</li> <li>• High pressure fuel pump</li> <li>• Low pressure fuel pump</li> <li>• Damage in lifter</li> </ul> |

DTC CONFIRMATION PROCEDURE

1. CHECK FUEL LEAKAGE

1. Turn ignition switch ON.
2. Visually check the piping between low pressure fuel pump and fuel injectors for fuel leakage.
3. Start the engine.
4. Visually check the piping between low pressure fuel pump and fuel injectors for fuel leakage.

Is inspection result normal?

- YES >> GO TO 2.
- NO >> Repair or replace error-detected parts.

2. PRECONDITIONING

If DTC CONFIRMATION PROCEDURE has been previously conducted, always perform the following procedure before conducting the next test.

1. Turn ignition switch OFF and wait at least 10 seconds.
2. Turn ignition switch ON.
3. Turn ignition switch OFF and wait at least 10 seconds.

TESTING CONDITION:

- Before performing the following procedure, confirm that battery voltage is 11 V or more at idle.
- Before performing the following procedure, check that the fuel tank is 1/8 full of fuel.

>> GO TO 3.

3. PERFORM DTC CONFIRMATION PROCEDURE-1

Ⓜ WITH CONSULT

1. Turn ignition switch ON.
2. Select "COOLAN TEMP/S" in "DATA MONITOR" mode of "ENGNE" using CONSULT.
3. Check the following condition;

|               |                         |
|---------------|-------------------------|
| COOLAN TEMP/S | : 5 – 40°C (41 – 104°F) |
|---------------|-------------------------|

< DTC/CIRCUIT DIAGNOSIS >

 WITH GST

Follow the above steps for "WITH CONSULT".

Is the condition satisfied?

- YES >> GO TO 4.
- NO >> 1. Satisfy the condition.
- 2. Retry from step 1.

**4.PERFORM DTC CONFIRMATION PROCEDURE-2**

 WITH CONSULT

1. Start the engine and let it idle for 10 seconds.
2. Check 1st trip DTC.

 WITH GST

Follow the above steps for "WITH CONSULT".

Is 1st trip DTC detected?

- YES >> Proceed to [EC-1740, "Diagnosis Procedure"](#).
- NO >> GO TO 5.

**5.PERFORM DTC CONFIRMATION PROCEDURE-3**

 WITH CONSULT

1. Select "COOLAN TEMP/S" in "DATA MONITOR" mode of "ENGINE" using CONSULT.
2. Maintain the following condition for 10 seconds or more at idle.

|                      |                               |
|----------------------|-------------------------------|
| <b>COOLAN TEMP/S</b> | <b>: 70°C (104°F) or more</b> |
|----------------------|-------------------------------|

3. Check 1st trip DTC.

 WITH GST

Follow the above steps for "WITH CONSULT".

Is 1st trip DTC detected?

- YES >> Proceed to [EC-1740, "Diagnosis Procedure"](#).
- NO >> INSPECTION END.

**Diagnosis Procedure**

INFOID:000000007785166

**1.BLEED THE FUEL LINE**

1. Start the engine, and let the engine run at idle at least for 10 minutes.
2. Perform DTC confirmation procedure of DTC P0087.

Is 1st trip DTC detected?

- YES >> GO TO 2.
- NO >> GO TO 6.

**2.CHECK LOW FUEL PRESSURE**

 WITH CONSULT

1. Start the engine.
2. Check "L/FUEL PRES SEN V" in "DATA MONITOR" mode of "ECM" using CONSULT.

| Monitor item      | Condition                         | Value (Approx.) |
|-------------------|-----------------------------------|-----------------|
| L/FUEL PRES SEN V | Engine speed: idle                | 3,000 –3,300 mV |
|                   | Engine speed: 3,000 rpm (no load) |                 |

 WITHOUT CONSULT

1. Start the engine.
2. Check low fuel pressure sensor signal voltage.

# P0087 FRP CONTROL SYSTEM

< DTC/CIRCUIT DIAGNOSIS >

[VK56VD FOR MEXICO]

| +         |          | -      | Condition   | Value (Approx.) |
|-----------|----------|--------|---|-----------------|
| Connector | Terminal |        |   |                 |
| F25       | 2        | Ground | Engine speed: idle<br>Engine speed: 3,000 rpm (no load) | 3.0 –3.3 V      |

Is inspection result normal?

YES >> GO TO 3.

NO >> Check low fuel pressure system. Refer to [EC-1989, "Diagnosis Procedure"](#).

## 3. CHECK LOW PRESSURE FUEL LINE FOR INTERNAL LEAKAGE

WITH CONSULT

1. Turn ignition switch OFF.
2. Turn ignition switch ON.
3. Select "L/FUEL PRES SEN" in "DATA MONITOR" of "ECM" with CONSULT.
4. Check the following value 30 minutes after turning the ignition switch ON.

**L/FUEL PRES SEN : More than 0.20 MPa**

WITHOUT CONSULT

1. Turn ignition switch OFF.
2. Connect fuel pressure gauge. Refer to [EC-1692, "Work Procedure"](#).
3. Turn ignition switch ON.
4. Check the following value 30 minutes after turning the ignition switch ON.

**Low fuel pressure : 206 kPa (2.1 bar, 2.2 kgf/cm<sup>2</sup>, 30 psi) or more**

Is inspection result normal?

YES >> GO TO 4.

NO >> Replace low pressure fuel pump. Refer to [FL-6, "Removal and Installation"](#).

## 4. CHECK HIGH PRESSURE FUEL PUMP

Check high pressure fuel pump. Refer to [EC-1742, "Component Inspection \(High Pressure Fuel Pump\)"](#).

Is inspection result normal?

YES >> GO TO 5.

NO >> Repair or replace the error-detected parts.

## 5. CHECK LIFTER

Check lifter. Refer to [EM-193, "Removal and Installation"](#).

Does the lifter top surface have scratches and/or dents?

YES >> Replace the error-detected parts.

NO >> Check intermittent incident. Refer to [GI-44, "Intermittent Incident"](#).

## 6. CHECK LOW PRESSURE FUEL LINE FOR INTERNAL LEAKAGE

WITH CONSULT

1. Turn ignition switch OFF.
2. Turn ignition switch ON.
3. Select "L/FUEL PRES SEN" in "DATA MONITOR" mode of "ECM" using CONSULT.
4. Check the following value 30 minutes after turning the ignition switch ON.

**L/FUEL PRES SEN : More than 0.20 MPa**

WITHOUT CONSULT

1. Turn ignition switch OFF.
2. Connect fuel pressure gauge. Refer to [EC-1692, "Work Procedure"](#).
3. Turn ignition switch ON.
4. Check the following value 30 minutes after turning the ignition switch ON.

# P0087 FRP CONTROL SYSTEM

< DTC/CIRCUIT DIAGNOSIS >

[VK56VD FOR MEXICO]

**Low fuel pressure : 206 kPa (2.1 bar, 2.2 kgf/cm<sup>2</sup>, 30 psi) or more**

Is inspection result normal?

- YES >> Check intermittent incident. Refer to [GI-44, "Intermittent Incident"](#).
- NO >> Replace low pressure fuel pump. Refer to [FL-6, "Removal and Installation"](#).

## Component Inspection (High Pressure Fuel Pump)

INFOID:000000007785167

### 1. CHECK HIGH PRESSURE FUEL PUMP-1

1. Turn ignition switch OFF.
2. Disconnect high pressure fuel pump harness connector.
3. Check the resistance between high pressure fuel pump terminals.

| +                                | - | Condition           |                   | Resistance (Approx.) |
|----------------------------------|---|---------------------|-------------------|----------------------|
| High pressure fuel pump Terminal |   |                     |                   |                      |
| 1                                | 2 | Temperature °C (°F) | 20 – 30 (68 - 86) | 9 - 11 Ω             |

Is the inspection result normal?

- YES >> GO TO 2.
- NO >> Replace high pressure fuel pump. Refer to [EM-193, "Removal and Installation"](#).

### 2. CHECK HIGH PRESSURE FUEL PUMP-2

WITH CONSULT

1. Reconnect high pressure fuel pump harness connector.
2. Start the engine.
3. Check "FUEL PRES SEN V" in "DATA MONITOR" mode of "ECM" using CONSULT.

| Monitor item    | Condition   | Voltage (Approx.) |
|-----------------|---|-------------------|
| FUEL PRES SEN V | Engine speed: idle  | 820 – 1,220 mV    |
|                 | Engine speed: Revving engine from idle to 4,000 rpm quickly | 820 – 3,060 mV    |

WITHOUT CONSULT

1. Reconnect high pressure fuel pump harness connector.
2. Start the engine.
3. Check FRP sensor signal voltage.

| ECM       |          |    | Condition   | Value (Approx.) |
|-----------|----------|----|---|-----------------|
| Connector | +        | -  |   |                 |
|           | Terminal |    |   |                 |
| F111      | 31       | 40 | Engine speed: idle  | 0.82 – 1.22 V   |
|           |          |    | Engine speed: Revving engine from idle to 4,000 rpm quickly | 0.82 – 3.06 V   |

- YES >> INSPECTION END
- NO >> Replace high pressure fuel pump. Refer to [EM-193, "Removal and Installation"](#).

P0088 FRP CONTROL SYSTEM

DTC Logic

INFOID:000000007785168

DTC DETECTION LOGIC

**NOTE:**

If DTC P0088 is displayed with DTC P0090, first perform the trouble diagnosis for DTC P0090.

| DTC No. | Trouble diagnosis name<br>(Trouble diagnosis content) | DTC detecting condition  | Possible cause   |
|---------|---|--|--|
| P0088   | HIGH FUEL PRES<br>(High fuel pressure too high)       | <ul style="list-style-type: none"> <li>Fuel rail pressure remains at more than 16.5 MPa (165 bar, 168.3 kg/cm<sup>2</sup>, 2392.5 psi) for 1 second or more during engine idle condition after cold start [water temperature 5°C (41°F) - 40°C (104°F)].</li> <li>The following condition continues for 5 seconds or more after engine start (regardless of water temperature):<br/>Actual fuel pressure – Target fuel pressure ≥ 2.7 MPa (27 bar, 27.5 kg/cm<sup>2</sup>, 392 psi)</li> </ul> | <ul style="list-style-type: none"> <li>Harness or connector (The high pressure fuel pump circuit is open or shorted)</li> <li>High pressure fuel pump</li> </ul> |

DTC CONFIRMATION PROCEDURE

1. PRECONDITIONING

If DTC CONFIRMATION PROCEDURE has been previously conducted, always perform the following procedure before conducting the next test.

- Turn ignition switch OFF and wait at least 10 seconds.
- Turn ignition switch ON.
- Turn ignition switch OFF and wait at least 10 seconds.

**TESTING CONDITION:**

- Before performing the following procedure, confirm that battery voltage is 11 V or more at idle.
- Before performing the following procedure, check that the fuel tank is 1/8 full of fuel.

>> GO TO 2.

2. PERFORM DTC CONFIRMATION PROCEDURE-1

- Warm up the engine to the normal operating temperature and keep the engine speed at idle for 10 seconds.

**NOTE:**

Warm up the engine until "COOLAN TEMP/S" on "DATA MONITOR" mode of "ENGINE" using CONSULT reaches at least 70°C (158°F).

- Check 1st trip DTC.

Is 1st trip DTC detected?

YES >> Proceed to [EC-1746. "Diagnosis Procedure"](#).

NO >> GO TO 3.

3. PERFORM DTC CONFIRMATION PROCEDURE-2

- Cool the engine until the engine coolant temperature reaches 60°C (140°F) or less.
- Start the engine and wait at least 40 seconds.
- Check 1st trip DTC.

Is 1st trip DTC detected?

YES >> Proceed to [EC-1746. "Diagnosis Procedure"](#).

NO >> INSPECTION END

Diagnosis Procedure

INFOID:000000007785169

1. CHECK LOW FUEL PRESSURE

# P0088 FRP CONTROL SYSTEM

< DTC/CIRCUIT DIAGNOSIS >

[VK56VD FOR MEXICO]

## Ⓟ WITH CONSULT

1. Start the engine.
2. Check "L/FUEL PRES SEN V" in "DATA MONITOR" mode of "ECM" using CONSULT.

| Monitor item      | Condition                         | Value (Approx.) |
|-------------------|-----------------------------------|-----------------|
| L/FUEL PRES SEN V | Engine speed: idle                | 3,000 -3,300 mV |
|                   | Engine speed: 3,000 rpm (no load) |                 |

## ⓧ WITHOUT CONSULT

1. Start the engine.
2. Check low fuel pressure sensor signal voltage.

| +                        |          | -      | Condition                         | Value (Approx.) |
|--------------------------|----------|--------|-----------------------------------|-----------------|
| Low fuel pressure sensor |          |        |                                   |                 |
| Connector                | Terminal |        |                                   |                 |
| F25                      | 2        | Ground | Engine speed: idle                | 3.0 -3.3 V      |
|                          |          |        | Engine speed: 3,000 rpm (no load) |                 |

Is inspection result normal?

YES >> GO TO 2.

NO >> Check low fuel pressure system. Refer to [EC-1989, "Diagnosis Procedure"](#).

## 2.CHECK HIGH PRESSURE FUEL PUMP

Check high pressure fuel pump. Refer to [EC-1744, "Component Inspection \(High Pressure Fuel Pump\)"](#).

Is inspection result normal?

YES >> GO TO 3.

NO >> Replace error-detected parts.

## 3.CHECK FUEL LEAKAGE

1. Start the engine.
2. Visually check that the fuel pump, fuel rail, and fuel piping have no fuel leakage.

Is inspection result normal?

YES >> Check that the fuel system has no breakage, bend, and crush. Refer to [FL-4, "Inspection"](#).

NO >> Replace or replace the error-detected parts.

## Component Inspection (High Pressure Fuel Pump)

INFOID:000000007785170

### 1.CHECK HIGH PRESSURE FUEL PUMP-1

1. Turn ignition switch OFF.
2. Disconnect high pressure fuel pump harness connector.
3. Check the resistance between high pressure fuel pump terminals.

| +                       |   | -                   |                   | Condition | Resistance (Approx.) |
|-------------------------|---|---------------------|-------------------|-----------|----------------------|
| High pressure fuel pump |   |                     |                   |           |                      |
| Terminal                |   |                     |                   |           |                      |
| 1                       | 2 | Temperature °C (°F) | 20 - 30 (68 - 86) | 9 - 11 Ω  |                      |

Is the inspection result normal?

YES >> GO TO 2.

NO >> Replace high pressure fuel pump. Refer to [EM-193, "Removal and Installation"](#).

### 2.CHECK HIGH PRESSURE FUEL PUMP-2

## Ⓟ WITH CONSULT

1. Reconnect high pressure fuel pump harness connector.
2. Start the engine.



# P0088 FRP CONTROL SYSTEM

< DTC/CIRCUIT DIAGNOSIS >

[VK56VD FOR MEXICO]

3. Check "FUEL PRES SEN V" in "DATA MONITOR" mode of "ECM" using CONSULT.

| Monitor item    | Condition   | Value (Approx.) |
|-----------------|---|-----------------|
| FUEL PRES SEN V | Engine speed: idle  | 820 – 1,220 mV  |
|                 | Engine speed: Revving engine from idle to 4,000 rpm quickly | 820 – 3,060 mV  |

WITHOUT CONSULT

1. Reconnect high pressure fuel pump harness connector.
2. Start the engine.
3. Check FRP sensor signal voltage.

| Connector | ECM |    | Condition   | Value (Approx.) |
|-----------|-----|----|---|-----------------|
|           | +   | -  |   |                 |
| Terminal  |     |    |   |                 |
| F111      | 31  | 40 | Engine speed: idle  | 0.82 – 1.22 V   |
|           |     |    | Engine speed: Revving engine from idle to 4,000 rpm quickly | 0.82 – 3.06 V   |

Is the inspection result normal?

YES >> INSPECTION END

NO >> Replace high pressure fuel pump. Refer to [EM-193. "Removal and Installation"](#).

A  
EC  
C  
D  
E  
F  
G  
H  
I  
J  
K  
L  
M  
N  
O  
P

# P0090 HIGH PRESSURE FUEL PUMP

< DTC/CIRCUIT DIAGNOSIS >

[VK56VD FOR MEXICO]

## P0090 HIGH PRESSURE FUEL PUMP

### DTC Logic

INFOID:000000007785171

### DTC DETECTION LOGIC

#### NOTE:

- If DTC P0090 is displayed with DTC P1197, first perform the trouble diagnosis for DTC P1197.
- DTC P0090 may be displayed when running out of gas.

| DTC No. | Trouble diagnosis name<br>(Trouble diagnosis content) | DTC detecting condition   | Possible cause  |
|---------|---|---|---|
| P0090   | FUEL PUMP<br>(High pressure fuel pump circuit)        | <ul style="list-style-type: none"><li>• Fuel rail pressure remains at 1.5 MPa (15 bar, 15.3 kg/cm<sup>2</sup>, 217.5 psi) or less for 3 seconds or more during engine rev.</li><li>• Fuel rail pressure remains at 18.5 MPa (185 bar, 188.7 kg/cm<sup>2</sup>, 2682.5 psi) or more for 0.3 seconds or more during engine rev.</li></ul> | <ul style="list-style-type: none"><li>• Harness or connectors<br/>(The fuel pump circuit is open or shorted.)</li><li>• High pressure fuel pump</li></ul> |

### DTC CONFIRMATION PROCEDURE

#### 1. PRECONDITIONING

If DTC CONFIRMATION PROCEDURE has been previously conducted, always perform the following procedure before conducting the next test.

1. Turn ignition switch OFF and wait at least 10 seconds.
2. Turn ignition switch ON.
3. Turn ignition switch OFF and wait at least 10 seconds.

#### TESTING CONDITION:

- Before performing the following procedure, confirm that battery voltage is 11 V or more at idle.
- Before performing the following procedure, check that the fuel tank is 1/8 full of fuel.

>> GO TO 2.

#### 2. PERFORM DTC CONFIRMATION PROCEDURE-I

##### WITH CONSULT

1. Start engine.
2. Select "COOLAN TEMP/S" in "DATA MONITOR" mode of "ENGNE" using CONSULT.
3. Maintain the following condition for 5 seconds or more at idle.

**COOLAN TEMP/S** : 70°C (104°F) or more

4. Check 1st trip DTC.

##### WITH GST

Follow the above steps for "WITH CONSULT".

Is 1st trip DTC detected?

- YES >> Proceed to [EC-1746, "Diagnosis Procedure"](#).
- NO >> INSPECTION END

### Diagnosis Procedure

INFOID:000000007785172

#### 1. CHECK HIGH PRESSURE FUEL PUMP CIRCUIT

1. Turn ignition switch ON.
2. Disconnect ECM harness connector and high pressure fuel pump harness connector.
3. Check the continuity between ECM harness connector and high pressure fuel pump harness connector.

# P0090 HIGH PRESSURE FUEL PUMP

< DTC/CIRCUIT DIAGNOSIS >

[VK56VD FOR MEXICO]

| +         |          | -                       |          | Value<br>(Approx.) |
|-----------|----------|-------------------------|----------|--------------------|
| ECM       |          | High pressure fuel pump |          |                    |
| Connector | Terminal | Connector               | Terminal |                    |
| F110      | 110      | F24                     | 2        | Existed            |
|           | 105      |                         | 1        |                    |

4. Also check harness for short to ground and to power.

Is inspection result normal?

YES >> GO TO 2.

NO >> Repair or replace the error-detected parts.

## 2.CHECK HIGH PRESSURE FUEL PUMP

Check high pressure fuel pump. Refer to [EC-1747, "Component Inspection \(High Pressure Fuel Pump\)"](#).

Is inspection result normal?

YES >> Check intermittent incident. Refer to [GI-44, "Intermittent Incident"](#).

NO >> Replace the error-detected parts.

## Component Inspection (High Pressure Fuel Pump)

INFOID:000000007785173

### 1.CHECK HIGH PRESSURE FUEL PUMP-1

1. Turn ignition switch OFF.
2. Disconnect high pressure fuel pump harness connector.
3. Check the resistance between high pressure fuel pump terminals.

| +                       |   | -                   |                   | Condition | Resistance<br>(Approx.) |
|-------------------------|---|---------------------|-------------------|-----------|-------------------------|
| High pressure fuel pump |   | Terminal            |                   |           |                         |
| 1                       | 2 | 1                   | 2                 |           |                         |
|                         |   | Temperature °C (°F) | 20 - 30 (68 - 86) |           | 9 - 11 Ω                |

Is the inspection result normal?

YES >> GO TO 2.

NO >> Replace high pressure fuel pump. Refer to [EM-193, "Removal and Installation"](#).

### 2.CHECK HIGH PRESSURE FUEL PUMP-2

#### Ⓜ WITH CONSULT

1. Reconnect high pressure fuel pump harness connector.
2. Start the engine.
3. Check "FUEL PRES SEN V" in "DATA MONITOR" mode of "ECM" using CONSULT.

| Monitor item    | Condition   | Value<br>(Approx.) |
|-----------------|---|--------------------|
| FUEL PRES SEN V | Engine speed: idle  | 820 - 1,220 mV     |
|                 | Engine speed: Revving engine from idle to 4,000 rpm quickly | 820 - 3,060 mV     |

#### Ⓧ WITHOUT CONSULT

1. Reconnect high pressure fuel pump harness connector.
2. Start the engine.
3. Check FRP sensor signal voltage.

# P0090 HIGH PRESSURE FUEL PUMP

< DTC/CIRCUIT DIAGNOSIS >

[VK56VD FOR MEXICO]

| ECM       |          |    | Condition   | Value<br>(Approx.) |
|-----------|----------|----|---|--------------------|
| Connector | +        | -  |   |                    |
|           | Terminal |    |   |                    |
| F111      | 31       | 40 | Engine speed: idle  | 0.82 – 1.22 V      |
|           |          |    | Engine speed: Revving engine from idle to 4,000 rpm quickly | 0.82 – 3.06 V      |

Is the inspection result normal?

YES >> INSPECTION END

NO >> Replace high pressure fuel pump. Refer to [EM-193, "Removal and Installation"](#).

# P0102, P0103, P010C, P010D MAF SENSOR

< DTC/CIRCUIT DIAGNOSIS >

[VK56VD FOR MEXICO]

## P0102, P0103, P010C, P010D MAF SENSOR

### DTC Logic

INFOID:000000007758248

### DTC DETECTION LOGIC

| DTC No. | Trouble diagnosis name<br>(Trouble diagnosis content)                       | DTC detecting condition  | Possible cause  |
|---------|---|--|---|
| P0102   | MAF SEN/CIRCUIT-B1<br>[Mass air flow sensor (bank 1)<br>circuit low input]  | An excessively low voltage from the sensor<br>is sent to ECM.  | <ul style="list-style-type: none"><li>• Harness or connectors<br/>(The mass air flow sensor (bank 1) cir-<br/>cuit is open or shorted.)</li><li>• Intake air leaks</li><li>• Mass air flow sensor</li></ul> |
| P0103   | MAF SEN/CIRCUIT-B1<br>[Mass air flow sensor (bank 1)<br>circuit high input] | An excessively high voltage from the sensor<br>is sent to ECM. | <ul style="list-style-type: none"><li>• Harness or connectors<br/>(The mass air flow sensor (bank 1) cir-<br/>cuit is open or shorted.)</li><li>• Mass air flow sensor</li></ul>                            |
| P010C   | MAF SEN/CIRCUIT-B2<br>[Mass air flow sensor (bank 2)<br>circuit low input]  | An excessively low voltage from the sensor<br>is sent to ECM.  | <ul style="list-style-type: none"><li>• Harness or connectors<br/>(The mass air flow sensor (bank 2) cir-<br/>cuit is open or shorted.)</li><li>• Intake air leaks</li><li>• Mass air flow sensor</li></ul> |
| P010D   | MAF SEN/CIRCUIT-B2<br>[Mass air flow sensor (bank 2)<br>circuit high input] | An excessively high voltage from the sensor<br>is sent to ECM. | <ul style="list-style-type: none"><li>• Harness or connectors<br/>(The mass air flow sensor (bank 2) cir-<br/>cuit is open or shorted.)</li><li>• Mass air flow sensor</li></ul>                            |

### DTC CONFIRMATION PROCEDURE

#### 1. PRECONDITIONING

If DTC Confirmation Procedure has been previously conducted, always perform the following procedure before conducting the next test.

1. Turn ignition switch OFF and wait at least 10 seconds.
2. Turn ignition switch ON.
3. Turn ignition switch OFF and wait at least 10 seconds.

#### Which DTC is detected?

P0102, P010C>>GO TO 2.

P0103, P010D>>GO TO 3.

#### 2. PERFORM DTC CONFIRMATION PROCEDURE FOR DTC P0102 AND P010C

1. Start engine and wait at least 5 seconds.
2. Check DTC.

#### Is DTC detected?

YES >> Proceed to [EC-1750, "Diagnosis Procedure"](#).

NO >> INSPECTION END

#### 3. PERFORM DTC CONFIRMATION PROCEDURE FOR DTC P0103 AND P010D-I

1. Turn ignition switch ON and wait at least 5 seconds.
2. Check DTC.

#### Is DTC detected?

YES >> Proceed to [EC-1750, "Diagnosis Procedure"](#).

NO >> GO TO 4.

#### 4. PERFORM DTC CONFIRMATION PROCEDURE FOR DTC P0103 AND P010D-II

1. Start engine and wait at least 5 seconds.
2. Check DTC.

#### Is DTC detected?

YES >> Proceed to [EC-1750, "Diagnosis Procedure"](#).

# P0102, P0103, P010C, P010D MAF SENSOR

< DTC/CIRCUIT DIAGNOSIS >

[VK56VD FOR MEXICO]

NO >> INSPECTION END

## Diagnosis Procedure

INFOID:000000007758249

### 1.INSPECTION START

Confirm the detected DTC.

Which DTC is detected?

P0102, P010C>>GO TO 2.

P0103, P010D>>GO TO 3.

### 2.CHECK INTAKE SYSTEM

Check the following for connection.

- Air duct
- Vacuum hoses
- Intake air passage between air duct to intake manifold

Is the inspection result normal?

YES >> GO TO 3.

NO >> Reconnect the parts.

### 3.CHECK MASS AIR FLOW SENSOR POWER SUPPLY CIRCUIT

1. Disconnect mass air flow (MAF) sensor harness connector.
2. Turn ignition switch ON.
3. Check the voltage between MAF sensor harness connector and ground.

| DTC          | MAF sensor |           |          | Ground | Voltage         |
|--------------|------------|-----------|----------|--------|-----------------|
|              | Bank       | Connector | Terminal |        |                 |
| P0102, P0103 | 1          | F86       | 5        | Ground | Battery voltage |
| P010C, P010D | 2          | F85       | 5        |        |                 |

Is the inspection result normal?

YES >> GO TO 5.

NO >> GO TO 4.

### 4.DETECT MALFUNCTIONING PART

Check the following.

- Harness for open or short between mass air flow sensor and ECM
- Harness for open or short between mass air flow sensor and IPDM E/R
- Loose or poor connection for each connector and harness

>> Repair open circuit, short to ground or short to power in harness or connectors.

### 5.CHECK MAF SENSOR GROUND CIRCUIT FOR OPEN AND SHORT

1. Turn ignition switch OFF.
2. Disconnect ECM harness connector.
3. Check the continuity between MAF sensor harness connector and ECM harness connector.

| DTC          | MAF sensor |           |          | ECM       |          | Continuity |
|--------------|------------|-----------|----------|-----------|----------|------------|
|              | Bank       | Connector | Terminal | Connector | Terminal |            |
| P0102, P0103 | 1          | F86       | 4        | F110      | 25       | Existed    |
| P010C, P010D | 2          | F85       | 4        |           | 30       |            |

4. Also check harness for short to ground and short to power.

Is the inspection result normal?

YES >> GO TO 6.

NO >> Repair open circuit, short to ground or short to power in harness or connectors.

### 6.CHECK MAF SENSOR INPUT SIGNAL CIRCUIT FOR OPEN AND SHORT

# P0102, P0103, P010C, P010D MAF SENSOR

< DTC/CIRCUIT DIAGNOSIS >

[VK56VD FOR MEXICO]

1. Check the continuity between MAF sensor harness connector and ECM harness connector.

| DTC          | MAF sensor |           |          | ECM       |          | Continuity |
|--------------|------------|-----------|----------|-----------|----------|------------|
|              | Bank       | Connector | Terminal | Connector | Terminal |            |
| P0102, P0103 | 1          | F86       | 3        | F110      | 22       | Existed    |
| P010C, P010D | 2          | F85       | 3        |           | 24       |            |

2. Also check harness for short to ground and short to power.

Is the inspection result normal?

YES >> GO TO 7.

NO >> Repair open circuit, short to ground or short to power in harness or connectors.

## 7. CHECK MASS AIR FLOW SENSOR

Refer to [EC-1751, "Component Inspection \(MAF Sensor\)"](#).

Is the inspection result normal?

YES >> GO TO 8.

NO >> Replace malfunctioning mass air flow sensor. Refer to [EM-184, "Removal and Installation"](#).

## 8. CHECK INTERMITTENT INCIDENT

Refer to [GI-44, "Intermittent Incident"](#).

>> INSPECTION END

## Component Inspection (MAF Sensor)

INFOID:000000007758250

### 1. CHECK MASS AIR FLOW SENSOR-I

#### Ⓜ WITH CONSULT

1. Turn ignition switch OFF.
2. Reconnect all harness connectors disconnected.
3. Start engine and warm it up to normal operating temperature.
4. Connect CONSULT and select "DATA MONITOR" mode.
5. Select "MAS A/F SE-B1" and "MAS A/F SE-B2", and check the indication.

| Monitor item                   | Condition  | Indication (V)              |
|--------------------------------|--|-----------------------------|
| MAS A/F SE-B1<br>MAS A/F SE-B2 | Ignition switch ON (Engine stopped.)                             | Approx. 0.4                 |
|                                | Idle (Engine is warmed-up to normal operating temperature.)      | 0.95 - 1.35                 |
|                                | 2,500 rpm (Engine is warmed-up to normal operating temperature.) | 1.3 - 1.7                   |
|                                | Idle to about 4,000 rpm  | 0.95 - 1.35 to Approx. 2.4* |

\*: Check for linear voltage rise in response to engine being increased to about 4,000 rpm.

#### ⓧ WITHOUT CONSULT

1. Turn ignition switch OFF.
2. Reconnect all harness connectors disconnected.
3. Start engine and warm it up to normal operating temperature.
4. Check the voltage between ECM harness connector terminals under the following conditions.

# P0102, P0103, P010C, P010D MAF SENSOR

< DTC/CIRCUIT DIAGNOSIS >

[VK56VD FOR MEXICO]

| ECM       |                                       |               | Condition  | Voltage (V)                 |
|-----------|---------------------------------------|---------------|--|-----------------------------|
| Connector | +<br>Terminal                         | -<br>Terminal |  |                             |
| F110      | 22<br>[MAF sensor (bank 1)<br>signal] | 25            | Ignition switch ON (Engine stopped.)                             | Approx. 0.4                 |
|           |                                       |               | Idle (Engine is warmed-up to normal operating temperature.)      | 0.95 - 1.35                 |
|           |                                       |               | 2,500 rpm (Engine is warmed-up to normal operating temperature.) | 1.3 - 1.7                   |
|           |                                       |               | Idle to about 4,000 rpm  | 0.95 - 1.35 to Approx. 2.4* |
|           | 24<br>[MAF sensor (bank 2)<br>signal] | 30            | Ignition switch ON (Engine stopped.)                             | Approx. 0.4                 |
|           |                                       |               | Idle (Engine is warmed-up to normal operating temperature.)      | 0.95 - 1.35                 |
|           |                                       |               | 2,500 rpm (Engine is warmed-up to normal operating temperature.) | 1.3 - 1.7                   |
|           |                                       |               | Idle to about 4,000 rpm  | 0.95 - 1.35 to Approx. 2.4* |

\*: Check for linear voltage rise in response to engine being increased to about 4,000 rpm.

**Is the inspection result normal?**

- YES >> INSPECTION END  
 NO >> GO TO 2.

## 2. CHECK FOR THE CAUSE OF UNEVEN AIR FLOW THROUGH MASS AIR FLOW SENSOR

1. Turn ignition switch OFF.
2. Check for the cause of uneven air flow through mass air flow sensor. Refer to the following.
  - Crushed air ducts
  - Malfunctioning seal of air cleaner element
  - Uneven dirt of air cleaner element
  - Improper specification of intake air system parts

**Is the inspection result normal?**

- YES >> GO TO 4.  
 NO >> GO TO 3.

## 3. CHECK MASS AIR FLOW SENSOR-II

**WITH CONSULT**

1. Repair or replace malfunctioning part.
2. Start engine and warm it up to normal operating temperature.
3. Connect CONSULT and select "DATA MONITOR" mode.
4. Select "MAS A/F SE-B1" and "MAS A/F SE-B2", and check the indication.

| Monitor item                   | Condition  | Indication (V)              |
|--------------------------------|--|-----------------------------|
| MAS A/F SE-B1<br>MAS A/F SE-B2 | Ignition switch ON (Engine stopped.)                             | Approx. 0.4                 |
|                                | Idle (Engine is warmed-up to normal operating temperature.)      | 0.95 - 1.35                 |
|                                | 2,500 rpm (Engine is warmed-up to normal operating temperature.) | 1.3 - 1.7                   |
|                                | Idle to about 4,000 rpm  | 0.95 - 1.35 to Approx. 2.4* |

\*: Check for linear voltage rise in response to engine being increased to about 4,000 rpm.

**WITHOUT CONSULT**

1. Repair or replace malfunctioning part.
2. Start engine and warm it up to normal operating temperature.
3. Check the voltage between ECM harness connector terminals under the following conditions.



# P0102, P0103, P010C, P010D MAF SENSOR

< DTC/CIRCUIT DIAGNOSIS >

[VK56VD FOR MEXICO]

| ECM       |                                       |          | Condition  | Voltage (V)                 |
|-----------|---------------------------------------|----------|--|-----------------------------|
| Connector | +                                     | -        |  |                             |
|           | Terminal                              | Terminal |  |                             |
| F110      | 22<br>[MAF sensor (bank 1)<br>signal] | 25       | Ignition switch ON (Engine stopped.)                             | Approx. 0.4                 |
|           |                                       |          | Idle (Engine is warmed-up to normal operating temperature.)      | 0.95 - 1.35                 |
|           |                                       |          | 2,500 rpm (Engine is warmed-up to normal operating temperature.) | 1.3 - 1.7                   |
|           |                                       |          | Idle to about 4,000 rpm  | 0.95 - 1.35 to Approx. 2.4* |
|           | 24<br>[MAF sensor (bank 2)<br>signal] | 30       | Ignition switch ON (Engine stopped.)                             | Approx. 0.4                 |
|           |                                       |          | Idle (Engine is warmed-up to normal operating temperature.)      | 0.95 - 1.35                 |
|           |                                       |          | 2,500 rpm (Engine is warmed-up to normal operating temperature.) | 1.3 - 1.7                   |
|           |                                       |          | Idle to about 4,000 rpm  | 0.95 - 1.35 to Approx. 2.4* |

\*: Check for linear voltage rise in response to engine being increased to about 4,000 rpm.

## Is the inspection result normal?

YES >> INSPECTION END

NO >> GO TO 4.

## 4. CHECK MASS AIR FLOW SENSOR-III

### WITH CONSULT

1. Turn ignition switch OFF.
2. Disconnect mass air flow sensor harness connector and reconnect it again.
3. Start engine and warm it up to normal operating temperature.
4. Connect CONSULT and select "DATA MONITOR" mode.
5. Select "MAS A/F SE-B1" and "MAS A/F SE-B2", and check the indication.

| Monitor item                   | Condition  | Indication (V)              |
|--------------------------------|--|-----------------------------|
| MAS A/F SE-B1<br>MAS A/F SE-B2 | Ignition switch ON (Engine stopped.)                             | Approx. 0.4                 |
|                                | Idle (Engine is warmed-up to normal operating temperature.)      | 0.95 - 1.35                 |
|                                | 2,500 rpm (Engine is warmed-up to normal operating temperature.) | 1.3 - 1.7                   |
|                                | Idle to about 4,000 rpm  | 0.95 - 1.35 to Approx. 2.4* |

\*: Check for linear voltage rise in response to engine being increased to about 4,000 rpm.

### WITHOUT CONSULT

1. Turn ignition switch OFF.
2. Disconnect mass air flow sensor harness connector and reconnect it again.
3. Start engine and warm it up to normal operating temperature.
4. Check the voltage between ECM harness connector terminals under the following conditions.

# P0102, P0103, P010C, P010D MAF SENSOR

< DTC/CIRCUIT DIAGNOSIS >

[VK56VD FOR MEXICO]

| ECM       |                                       |          | Condition  | Voltage (V)                 |
|-----------|---------------------------------------|----------|--|-----------------------------|
| Connector | +                                     | -        |  |                             |
|           | Terminal                              | Terminal |  |                             |
| F110      | 22<br>[MAF sensor (bank 1)<br>signal] | 25       | Ignition switch ON (Engine stopped.)                             | Approx. 0.4                 |
|           |                                       |          | Idle (Engine is warmed-up to normal operating temperature.)      | 0.95 - 1.35                 |
|           |                                       |          | 2,500 rpm (Engine is warmed-up to normal operating temperature.) | 1.3 - 1.7                   |
|           |                                       |          | Idle to about 4,000 rpm  | 0.95 - 1.35 to Approx. 2.4* |
|           | 24<br>[MAF sensor (bank 2)<br>signal] | 30       | Ignition switch ON (Engine stopped.)                             | Approx. 0.4                 |
|           |                                       |          | Idle (Engine is warmed-up to normal operating temperature.)      | 0.95 - 1.35                 |
|           |                                       |          | 2,500 rpm (Engine is warmed-up to normal operating temperature.) | 1.3 - 1.7                   |
|           |                                       |          | Idle to about 4,000 rpm  | 0.95 - 1.35 to Approx. 2.4* |

\*: Check for linear voltage rise in response to engine being increased to about 4,000 rpm.

**Is the inspection result normal?**

YES >> INSPECTION END

NO >> Clean or replace malfunctioning mass air flow sensor. Refer to [EM-184, "Removal and Installation"](#).

# P0112, P0113 IAT SENSOR

< DTC/CIRCUIT DIAGNOSIS >

[VK56VD FOR MEXICO]

## P0112, P0113 IAT SENSOR

### DTC Logic

INFOID:000000007758257

### DTC DETECTION LOGIC

| DTC No. | Trouble diagnosis name<br>(Trouble diagnosis content)                    | DTC detecting condition                                     | Possible cause   |
|---------|--|---|--|
| P0112   | IAT SEN/CIRCUIT-B1<br>(Intake air temperature sensor circuit low input)  | An excessively low voltage from the sensor is sent to ECM.  | <ul style="list-style-type: none"> <li>• Harness or connectors<br/>(The intake air temperature sensor circuit is open or shorted.)</li> <li>• Intake air temperature sensor</li> </ul> |
| P0113   | IAT SEN/CIRCUIT-B1<br>(Intake air temperature sensor circuit high input) | An excessively high voltage from the sensor is sent to ECM. |  |

### DTC CONFIRMATION PROCEDURE

#### 1. PRECONDITIONING

If DTC Confirmation Procedure has been previously conducted, always perform the following procedure before conducting the next test.

1. Turn ignition switch OFF and wait at least 10 seconds.
2. Turn ignition switch ON.
3. Turn ignition switch OFF and wait at least 10 seconds.

>> GO TO 2.

#### 2. PERFORM DTC CONFIRMATION PROCEDURE

1. Turn ignition switch ON and wait at least 5 seconds.
2. Check 1st trip DTC.

Is 1st trip DTC detected?

- YES >> Proceed to [EC-1755, "Diagnosis Procedure"](#).  
 NO >> INSPECTION END

### Diagnosis Procedure

INFOID:000000007758258

#### 1. CHECK INTAKE AIR TEMPERATURE SENSOR POWER SUPPLY CIRCUIT

1. Disconnect mass air flow (MAF) sensor (bank 1) (intake air temperature sensor is built-in) harness connector.
2. Turn ignition switch ON.
3. Check the voltage between MAF sensor (bank 1) harness connector and ground.

| MAF sensor (bank 1) |          | Ground | Voltage (V) |
|---------------------|----------|--------|-------------|
| Connector           | Terminal |        |             |
| F86                 | 2        | Ground | Approx. 5   |

Is the inspection result normal?

- YES >> GO TO 2.  
 NO >> Repair open circuit, short to ground or short to power in harness or connectors.

#### 2. CHECK INTAKE AIR TEMPERATURE SENSOR GROUND CIRCUIT FOR OPEN AND SHORT

1. Turn ignition switch OFF.
2. Disconnect ECM harness connector.
3. Check the continuity between MAF sensor (bank 1) harness connector and ECM harness connector.

| MAF sensor (bank 1) |          | ECM       |          | Continuity |
|---------------------|----------|-----------|----------|------------|
| Connector           | Terminal | Connector | Terminal |            |
| F86                 | 1        | F110      | 25       | Existed    |

# P0112, P0113 IAT SENSOR

[VK56VD FOR MEXICO]

< DTC/CIRCUIT DIAGNOSIS >

4. Also check harness for short to ground and short to power.

Is the inspection result normal?

YES >> GO TO 3.

NO >> Repair open circuit, short to ground or short to power in harness or connectors.

## 3. CHECK INTAKE AIR TEMPERATURE SENSOR

Refer to [EC-1756, "Component Inspection \(Intake Air Temperature Sensor\)"](#).

Is the inspection result normal?

YES >> GO TO 4.

NO >> Replace mass air flow sensor (bank 1) (with intake air temperature sensor). Refer to [EM-184, "Removal and Installation"](#).

## 4. CHECK INTERMITTENT INCIDENT

Refer to [GI-44, "Intermittent Incident"](#).

>> INSPECTION END

## Component Inspection (Intake Air Temperature Sensor)

INFOID:000000007758259

## 1. CHECK INTAKE AIR TEMPERATURE SENSOR

1. Turn ignition switch OFF.
2. Disconnect mass air flow sensor (bank 1) harness connector.
3. Check resistance between mass air flow sensor (bank 1) terminals as per the following.

| Terminals | Condition             | Resistance (kΩ)     |
|-----------|-----------------------|---------------------|
| 1 and 2   | Temperature [°C (°F)] | 25 (77) 1.94 - 2.06 |

Is the inspection result normal?

YES >> INSPECTION END

NO >> Replace mass air flow sensor (bank 1) (with intake air temperature sensor). Refer to [EM-184, "Removal and Installation"](#).

# P0117, P0118 ECT SENSOR

[VK56VD FOR MEXICO]

< DTC/CIRCUIT DIAGNOSIS >

## P0117, P0118 ECT SENSOR

### DTC Logic

INFOID:000000007758263

### DTC DETECTION LOGIC

| DTC No. | Trouble diagnosis name<br>(Trouble diagnosis content)                  | DTC detecting condition                                     | Possible cause   |
|---------|--|---|--|
| P0117   | ECT SEN/CIRC<br>(Engine coolant temperature sensor circuit low input)  | An excessively low voltage from the sensor is sent to ECM.  | <ul style="list-style-type: none"> <li>• Harness or connectors (The engine coolant temperature sensor circuit is open or shorted.)</li> <li>• Engine coolant temperature sensor</li> </ul> |
| P0118   | ECT SEN/CIRC<br>(Engine coolant temperature sensor circuit high input) | An excessively high voltage from the sensor is sent to ECM. |  |

### DTC CONFIRMATION PROCEDURE

#### 1. PRECONDITIONING

If DTC Confirmation Procedure has been previously conducted, always perform the following procedure before conducting the next test.

1. Turn ignition switch OFF and wait at least 10 seconds.
2. Turn ignition switch ON.
3. Turn ignition switch OFF and wait at least 10 seconds.

>> GO TO 2.

#### 2. PERFORM DTC CONFIRMATION PROCEDURE

1. Turn ignition switch ON and wait at least 5 seconds.
2. Check DTC.

Is DTC detected?

- YES >> Proceed to [EC-1757, "Diagnosis Procedure"](#).  
 NO >> INSPECTION END

### Diagnosis Procedure

INFOID:000000007758264

#### 1. CHECK ENGINE COOLANT TEMPERATURE SENSOR POWER SUPPLY CIRCUIT

1. Disconnect engine coolant temperature (ECT) sensor harness connector.
2. Turn ignition switch ON.
3. Check the voltage between ECT sensor harness connector and ground.

| ECT sensor |          | Ground | Voltage (V) |
|------------|----------|--------|-------------|
| Connector  | Terminal |        |             |
| F17        | 1        | Ground | Approx. 5   |

Is the inspection result normal?

- YES >> GO TO 2.  
 NO >> Repair open circuit, short to ground or short to power in harness or connectors.

#### 2. CHECK ECT SENSOR GROUND CIRCUIT FOR OPEN AND SHORT

1. Turn ignition switch OFF.
2. Disconnect ECM harness connector.
3. Check the continuity between ECT sensor harness connector and ECM harness connector.

| ECT sensor |          | ECM       |          | Continuity |
|------------|----------|-----------|----------|------------|
| Connector  | Terminal | Connector | Terminal |            |
| F17        | 2        | F110      | 40       | Existed    |

# P0117, P0118 ECT SENSOR

[VK56VD FOR MEXICO]

## < DTC/CIRCUIT DIAGNOSIS >

4. Also check harness for short to ground and short to power.

Is the inspection result normal?

YES >> GO TO 3.

NO >> Repair open circuit, short to ground or short to power in harness or connectors.

### 3. CHECK ENGINE COOLANT TEMPERATURE SENSOR

Refer to [EC-1758, "Component Inspection \(Engine Coolant Temperature Sensor\)"](#).

Is the inspection result normal?

YES >> GO TO 4.

NO >> Replace engine coolant temperature sensor. Refer to [EM-264, "Exploded View"](#).

### 4. CHECK INTERMITTENT INCIDENT

Refer to [GI-44, "Intermittent Incident"](#).

>> INSPECTION END

## Component Inspection (Engine Coolant Temperature Sensor)

INFOID:000000007758265

### 1. CHECK ENGINE COOLANT TEMPERATURE SENSOR

1. Turn ignition switch OFF.
2. Disconnect engine coolant temperature sensor harness connector.
3. Remove engine coolant temperature sensor.
4. Check resistance between engine coolant temperature sensor terminals by heating with hot water as shown in the figure.

| Terminals | Condition                                   | Resistance (k $\Omega$ ) |               |
|-----------|---|--------------------------|---------------|
| 1 and 2   | Temperature [ $^{\circ}$ C ( $^{\circ}$ F)] | 20 (68)                  | 2.1 - 2.9     |
|           |   | 50 (122)                 | 0.68 - 1.00   |
|           |   | 90 (194)                 | 0.236 - 0.260 |

Is the inspection result normal?

YES >> INSPECTION END

NO >> Replace engine coolant temperature sensor.

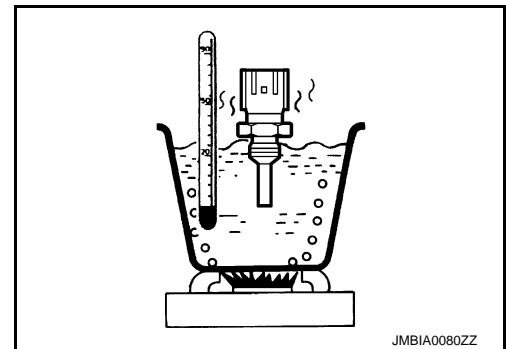

# P0122, P0123, P0227, P0228 TP SENSOR

< DTC/CIRCUIT DIAGNOSIS >

[VK56VD FOR MEXICO]

## P0122, P0123, P0227, P0228 TP SENSOR

### DTC Logic

INFOID:000000007758266

### DTC DETECTION LOGIC

#### NOTE:

If DTC P0122, P0123, P0227 or P0228 is displayed with DTC P0643, first perform the trouble diagnosis for DTC P0643. Refer to [EC-1863, "DTC Logic"](#).

| DTC No. | Trouble diagnosis name<br>(Trouble diagnosis content)                           | DTC detecting condition  | Possible cause  |
|---------|---|--|---|
| P0122   | TP SEN 2/CIRC-B1<br>[Throttle position sensor 2<br>(bank 1) circuit low input]  | An excessively low voltage from the TP sensor 2 is sent to ECM.  | <ul style="list-style-type: none"> <li>• Harness or connectors (TP sensor 2 circuit is open or shorted.)</li> <li>• Electric throttle control actuator (TP sensor 2)</li> </ul> |
| P0123   | TP SEN 2/CIRC-B1<br>[Throttle position sensor 2<br>(bank 1) circuit high input] | An excessively high voltage from the TP sensor 2 is sent to ECM. |   |
| P0227   | TP SEN 2/CIRC-B2<br>[Throttle position sensor 2<br>(bank 2) circuit low input]  | An excessively low voltage from the TP sensor 2 is sent to ECM.  |   |
| P0228   | TP SEN 2/CIRC-B2<br>[Throttle position sensor 2<br>(bank 2) circuit high input] | An excessively high voltage from the TP sensor 2 is sent to ECM. |   |

### DTC CONFIRMATION PROCEDURE

#### 1. PRECONDITIONING

1. Turn ignition switch OFF and wait at least 10 seconds.
2. Turn ignition switch ON.
3. Turn ignition switch OFF and wait at least 10 seconds.

#### TESTING CONDITION:

Before performing the following procedure, confirm that battery voltage is 8 V or more at idle.

>> GO TO 2.

#### 2. PERFORM DTC CONFIRMATION PROCEDURE

1. Start engine and let it idle for 1 second.
2. Check DTC.

#### Is DTC detected?

YES >> Proceed to [EC-1759, "Diagnosis Procedure"](#).

NO >> INSPECTION END

### Diagnosis Procedure

INFOID:000000007758267

#### 1. CHECK THROTTLE POSITION SENSOR 2 POWER SUPPLY CIRCUIT-I

1. Disconnect electric throttle control actuator harness connector.
2. Turn ignition switch ON.
3. Check the voltage between electric throttle control actuator harness connector and ground.

| DTC          | Electric throttle control actuator |           |          | Ground | Voltage (V) |
|--------------|------------------------------------|-----------|----------|--------|-------------|
|              | Bank                               | Connector | Terminal |        |             |
| P0122, P0123 | 1                                  | F66       | 2        | Ground | Approx. 5   |
| P0227, P0228 | 2                                  | F64       | 2        |        |             |

#### Is the inspection result normal?

YES >> GO TO 2.

NO >> Repair open circuit, short to ground or short to power in harness or connectors.

# P0122, P0123, P0227, P0228 TP SENSOR

< DTC/CIRCUIT DIAGNOSIS >

[VK56VD FOR MEXICO]

## 2. CHECK THROTTLE POSITION SENSOR 2 GROUND CIRCUIT FOR OPEN AND SHORT

1. Turn ignition switch OFF.
2. Disconnect ECM harness connector.
3. Check the continuity between electric throttle control actuator harness connector and ECM harness connector.

| DTC          | Electric throttle control actuator |           |          | ECM       |          | Continuity |
|--------------|------------------------------------|-----------|----------|-----------|----------|------------|
|              | Bank                               | Connector | Terminal | Connector | Terminal |            |
| P0122, P0123 | 1                                  | F66       | 4        | F111      | 97       | Existed    |
| P0227, P0228 | 2                                  | F64       | 4        |           | 69       |            |

4. Also check harness for short to ground and short to power.

Is the inspection result normal?

YES >> GO TO 3.

NO >> Repair open circuit, short to ground or short to power in harness or connectors.

## 3. CHECK THROTTLE POSITION SENSOR 2 INPUT SIGNAL CIRCUIT FOR OPEN AND SHORT

1. Check the continuity between electric throttle control actuator harness connector and ECM harness connector.

| DTC          | Electric throttle control actuator |           |          | ECM       |          | Continuity |
|--------------|------------------------------------|-----------|----------|-----------|----------|------------|
|              | Bank                               | Connector | Terminal | Connector | Terminal |            |
| P0122, P0123 | 1                                  | F66       | 3        | F111      | 79       | Existed    |
| P0227, P0228 | 2                                  | F64       | 3        |           | 89       |            |

2. Also check harness for short to ground and short to power.

Is the inspection result normal?

YES >> GO TO 4.

NO >> Repair open circuit, short to ground or short to power in harness or connectors.

## 4. CHECK THROTTLE POSITION SENSOR

Refer to [EC-1760, "Component Inspection \(Throttle Position Sensor\)"](#).

Is the inspection result normal?

YES >> GO TO 6.

NO >> GO TO 5.

## 5. REPLACE ELECTRIC THROTTLE CONTROL ACTUATOR

Replace malfunctioning electric throttle control actuator. Refer to [EM-191, "Removal and Installation"](#).

>> INSPECTION END

## 6. CHECK INTERMITTENT INCIDENT

Refer to [GI-44, "Intermittent Incident"](#).

>> INSPECTION END

## Component Inspection (Throttle Position Sensor)

INFOID:000000007758268

### 1. CHECK THROTTLE POSITION SENSOR

1. Turn ignition switch OFF.
2. Reconnect all harness connectors disconnected.
3. Perform [EC-1686, "Work Procedure"](#).
4. Turn ignition switch ON.
5. Set selector lever position to D.
6. Check the voltage between ECM harness connector terminals under the following conditions.



# P0122, P0123, P0227, P0228 TP SENSOR

< DTC/CIRCUIT DIAGNOSIS >

[VK56VD FOR MEXICO]

| ECM       |                              |               | Condition                          | Voltage (V)    |
|-----------|------------------------------|---------------|------------------------------------|----------------|
| Connector | +<br>Terminal                | -<br>Terminal |                                    |                |
| F111      | 91<br>[TP sensor 1 (bank 1)] | 97            | Accelerator pedal: Fully released  | More than 0.36 |
|           |                              |               | Accelerator pedal: Fully depressed | Less than 4.75 |
|           | 71<br>[TP sensor 1 (bank 2)] | 69            | Accelerator pedal: Fully released  | More than 0.36 |
|           |                              |               | Accelerator pedal: Fully depressed | Less than 4.75 |
|           | 79<br>[TP sensor 2 (bank 1)] | 97            | Accelerator pedal: Fully released  | Less than 4.75 |
|           |                              |               | Accelerator pedal: Fully depressed | More than 0.36 |
|           | 89<br>[TP sensor 2 (bank 2)] | 69            | Accelerator pedal: Fully released  | Less than 4.75 |
|           |                              |               | Accelerator pedal: Fully depressed | More than 0.36 |

Is the inspection result normal?

YES >> INSPECTION END

NO >> GO TO 2.

## 2. REPLACE ELECTRIC THROTTLE CONTROL ACTUATOR

Replace malfunctioning electric throttle control actuator. Refer to [EM-191. "Removal and Installation"](#).

>> INSPECTION END

A  
EC  
C  
D  
E  
F  
G  
H  
I  
J  
K  
L  
M  
N  
O  
P

P0125 ECT SENSOR

DTC Logic

INFOID:000000007758269

DTC DETECTION LOGIC

NOTE:

If DTC P0125 is displayed with P0117 or P0118, first perform the trouble diagnosis for DTC P0117, P0118. Refer to [EC-1757. "DTC Logic"](#).

| DTC No. | Trouble diagnosis name<br>(Trouble diagnosis content)                                | DTC detecting condition   | Possible cause  |
|---------|--|---|---|
| P0125   | ECT SENSOR<br>(Insufficient engine coolant temperature for closed loop fuel control) | <ul style="list-style-type: none"> <li>Voltage sent to ECM from the sensor is not practical, even when some time has passed after starting the engine.</li> <li>Engine coolant temperature is insufficient for closed loop fuel control.</li> </ul> | <ul style="list-style-type: none"> <li>Harness or connectors (High resistance in the circuit)</li> <li>Engine coolant temperature sensor</li> <li>Thermostat</li> </ul> |

DTC CONFIRMATION PROCEDURE

1. PRECONDITIONING

If DTC Confirmation Procedure has been previously conducted, always perform the following procedure before conducting the next test.

- Turn ignition switch OFF and wait at least 10 seconds.
- Turn ignition switch ON.
- Turn ignition switch OFF and wait at least 10 seconds.

>> GO TO 2.

2. CHECK ENGINE COOLANT TEMPERATURE SENSOR FUNCTION

 WITH CONSULT

- Turn ignition switch ON.
- Select "DATA MONITOR" mode with CONSULT.
- Check that "COOLAN TEMP/S" is above 10°C (50°F).

 WITH GST

Follow the procedure "With CONSULT" above.

Is the temperature above 10°C (50°F)?

- YES >> INSPECTION END  
NO >> GO TO 3.

3. PERFORM DTC CONFIRMATION PROCEDURE

 WITH CONSULT

- Start engine and run it for 65 minutes at idle speed.  
If "COOLAN TEMP/S" increases to more than 10°C (50°F) within 65 minutes, stop engine because the test result will be OK.

**CAUTION:**

**Never overheat engine.**

- Check 1st trip DTC.

 WITH GST

Follow the procedure "With CONSULT" above.

Is 1st trip DTC detected?

- YES >> [EC-1762. "Diagnosis Procedure"](#)  
NO >> INSPECTION END

Diagnosis Procedure

INFOID:000000007758270

1. CHECK ENGINE COOLANT TEMPERATURE SENSOR

Refer to [EC-1758. "Component Inspection \(Engine Coolant Temperature Sensor\)"](#).

Is the inspection result normal?

# P0125 ECT SENSOR

[VK56VD FOR MEXICO]

## < DTC/CIRCUIT DIAGNOSIS >

- YES >> GO TO 2.
- NO >> Replace engine coolant temperature sensor.

## 2.CHECK THERMOSTAT OPERATION

When the engine is cold [lower than 70°C (158°F)] condition, grasp lower radiator hose and confirm that the engine coolant does not flow.

Is the inspection result normal?

- YES >> GO TO 3.
- NO >> Repair or replace thermostat. Refer to [CO-48. "Removal and Installation"](#).

## 3.CHECK INTERMITTENT INCIDENT

Refer to [GI-44. "Intermittent Incident"](#).

>> INSPECTION END

## Component Inspection (Engine Coolant Temperature Sensor)

INFOID:000000007758271

## 1.CHECK ENGINE COOLANT TEMPERATURE SENSOR

1. Turn ignition switch OFF.
2. Disconnect engine coolant temperature sensor harness connector.
3. Remove engine coolant temperature sensor.
4. Check resistance between engine coolant temperature sensor terminals by heating with hot water as shown in the figure.

| Terminals | Condition             | Resistance (kΩ) |               |
|-----------|-----------------------|-----------------|---------------|
| 1 and 2   | Temperature [°C (°F)] | 20 (68)         | 2.1 - 2.9     |
|           |                       | 50 (122)        | 0.68 - 1.00   |
|           |                       | 90 (194)        | 0.236 - 0.260 |

Is the inspection result normal?

- YES >> INSPECTION END
- NO >> Replace engine coolant temperature sensor.

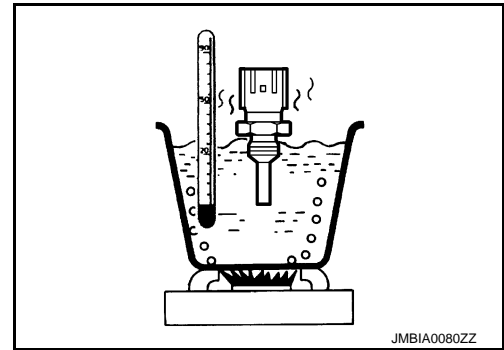

P0130, P0150 A/F SENSOR 1

DTC Logic

INFOID:000000007758278

DTC DETECTION LOGIC

To judge malfunctions, the diagnosis checks that the A/F signal computed by ECM from the A/F sensor 1 signal fluctuates according to fuel feedback control.

| DTC No. | Trouble diagnosis name<br>(Trouble diagnosis content)                   | DTC detecting condition |  | Possible Cause   |
|---------|---|-------------------------|--|--|
| P0130   | A/F SENSOR1 (B1)<br>[Air fuel ratio (A/F) sensor 1<br>(bank 1) circuit] | A)                      | The A/F signal computed by ECM from the A/F sensor 1 signal is constantly in a range other than approx. 1.5 V. | <ul style="list-style-type: none"> <li>• Harness or connectors (The A/F sensor 1 circuit is open or shorted.)</li> <li>• A/F sensor 1</li> </ul> |
|         |   | B)                      | The A/F signal computed by ECM from the A/F sensor 1 signal is constantly approx. 1.5 V.                       |  |
| P0150   | A/F SENSOR1 (B2)<br>[Air fuel ratio (A/F) sensor 1<br>(bank 2) circuit] | A)                      | The A/F signal computed by ECM from the A/F sensor 1 signal is constantly in a range other than approx.1.5 V.  |  |
|         |   | B)                      | The A/F signal computed by ECM from the A/F sensor 1 signal is constantly approx. 1.5 V.                       |  |

DTC CONFIRMATION PROCEDURE

1. PRECONDITIONING

1. Turn ignition switch OFF and wait at least 10 seconds.
2. Turn ignition switch ON.
3. Turn ignition switch OFF and wait at least 10 seconds.

**TESTING CONDITION:**

**Before performing the following procedure, confirm that battery voltage is 11 V or more at idle.**

>> GO TO 2.

2. PERFORM DTC CONFIRMATION PROCEDURE FOR MALFUNCTION A

1. Start engine and warm it up to normal operating temperature.
2. Let engine idle for 2 minutes.
3. Check 1st trip DTC.

Is 1st trip DTC detected?

- YES >> Proceed to [EC-1766. "Diagnosis Procedure"](#).
- NO-1 >> With CONSULT: GO TO 3.
- NO-2 >> With GST: GO TO 7.

3. CHECK AIR FUEL RATIO (A/F) SENSOR 1 FUNCTION

Ⓟ WITH CONSULT

1. Start engine and warm it up to normal operating temperature.
2. Select "A/F SEN1 (B1)" or "A/F SEN1 (B2)" in "DATA MONITOR" mode with CONSULT.
3. Check "A/F SEN1 (B1)" or "A/F SEN1 (B2)" indication.

Does the indication fluctuate around 1.5 V?

- YES >> GO TO 4.
- NO >> Proceed to [EC-1766. "Diagnosis Procedure"](#).

4. PERFORM DTC CONFIRMATION PROCEDURE FOR MALFUNCTION B-I

1. Select "A/F SEN1 (B1) P1276" (for DTC P0130) or "A/F SEN1 (B2) P1286" (for DTC P0150) of "A/F SEN1" in "DTC WORK SUPPORT" mode with CONSULT.
2. Touch "START".
3. When the following conditions are met, "TESTING" will be displayed on the CONSULT screen.

|                |                            |
|----------------|----------------------------|
| ENG SPEED      | 1,750 - 3,200 rpm          |
| VHCL SPEED SE  | More than 64 km/h (40 mph) |
| B/FUEL SCHDL   | 1.0 - 8.0 msec             |
| Selector lever | D position                 |

A

EC

If "TESTING" is not displayed after 20 seconds, retry from step 2.

**CAUTION:**

Always drive vehicle at a safe speed.

C

Is "TESTING" displayed on CONSULT screen?

D

YES >> GO TO 5.

NO >> Check A/F sensor 1 function again. GO TO 3.

**5. PERFORM DTC CONFIRMATION PROCEDURE FOR MALFUNCTION B-II**

Release accelerator pedal fully.

**NOTE:**

Never apply brake when releasing the accelerator pedal.

E

Which does "TESTING" change to?

F

COMPLETED>>GO TO 6.

OUT OF CONDITION>>Retry DTC CONFIRMATION PROCEDURE. GO TO 4.

**6. PERFORM DTC CONFIRMATION PROCEDURE FOR MALFUNCTION B-III**

G

Touch "SELF-DIAG RESULT".

Which is displayed on CONSULT screen?

H

YES >> INSPECTION END

NO >> Proceed to [EC-1766, "Diagnosis Procedure"](#).

**7. PERFORM COMPONENT FUNCTION CHECK FOR MALFUNCTION B**

I

 With GST

Perform component function check. Refer to [EC-1765, "Component Function Check"](#).

**NOTE:**

Use component function check to check the overall function of the A/F sensor 1 circuit. During this check, a 1st trip DTC might not be confirmed.

J

Is the inspection result normal?

K

YES >> INSPECTION END

NO >> Proceed to [EC-1766, "Diagnosis Procedure"](#).

**Component Function Check**

INFOID:000000007758279

L

**1. PERFORM COMPONENT FUNCTION CHECK**

M

 With GST

1. Start engine and warm it up to normal operating temperature.
2. Drive the vehicle at a speed of 80 km/h (50 MPH) for a few minutes in the suitable gear position.
3. Shift the selector lever position to D, then release the accelerator pedal fully until the vehicle speed decreases to 50 km/h (31 MPH).

N

**CAUTION:**

Always drive vehicle at a safe speed.

O

**NOTE:**

Never apply brake when releasing the accelerator pedal.

4. Repeat steps 2 and 3 for 5 times.
5. Stop the vehicle and turn ignition switch OFF.
6. Wait at least 10 seconds and turn ignition switch ON.
7. Turn ignition switch OFF and wait at least 10 seconds.
8. Restart engine.
9. Repeat steps 2 and 3 for 5 times.
10. Stop the vehicle.
11. Check 1st trip DTC.

P

# P0130, P0150 A/F SENSOR 1

< DTC/CIRCUIT DIAGNOSIS >

[VK56VD FOR MEXICO]

Is 1st trip DTC detected?

YES >> Proceed to [EC-1766, "Diagnosis Procedure"](#).

NO >> INSPECTION END

## Diagnosis Procedure

INFOID:000000007758280

### 1. CHECK AIR FUEL RATIO SENSOR 1 POWER SUPPLY CIRCUIT

1. Disconnect air fuel ratio (A/F) sensor 1 harness connector.
2. Turn ignition switch ON.
3. Check the voltage between A/F sensor 1 harness connector and ground.

| DTC   | A/F sensor 1 |           |          | Ground | Voltage |
|-------|--------------|-----------|----------|--------|---------|
|       | Bank         | Connector | Terminal |        |         |
| P0130 | 1            | F23       | 4        | Ground | 3.0 V   |
| P0150 | 2            | F24       | 4        |        |         |

Is the inspection result normal?

YES >> GO TO 2.

NO >> Repair open circuit, short to ground or short to power in harness or connectors.

### 2. CHECK A/F SENSOR 1 INPUT SIGNAL CIRCUIT FOR OPEN AND SHORT

1. Turn ignition switch OFF.
2. Disconnect ECM harness connector.
3. Check the continuity between A/F sensor 1 harness connector and ECM harness connector.

| DTC   | A/F sensor 1 |           |          | ECM       |          | Continuity |
|-------|--------------|-----------|----------|-----------|----------|------------|
|       | Bank         | Connector | Terminal | Connector | Terminal |            |
| P0130 | 1            | F23       | 3        | F111      | 88       | Existed    |
| P0150 | 2            | F24       | 3        |           | 78       |            |

4. Check the continuity between A/F sensor 1 harness connector and ground, or ECM harness connector and ground.

| DTC   | A/F sensor 1 |           |          | ECM       |          | Ground | Continuity  |
|-------|--------------|-----------|----------|-----------|----------|--------|-------------|
|       | Bank         | Connector | Terminal | Connector | Terminal |        |             |
| P0130 | 1            | F23       | 3        | F111      | 88       | Ground | Not existed |
| P0150 | 2            | F24       | 3        |           | 78       |        |             |

5. Also check harness for short to power.

Is the inspection result normal?

YES >> GO TO 3.

NO >> Repair open circuit, short to ground or short to power in harness or connectors.

### 3. CHECK A/F SENSOR 1 GROUND CIRCUIT FOR OPEN AND SHORT

1. Turn ignition switch OFF.
2. Disconnect ECM harness connector.
3. Check the continuity between A/F sensor 1 harness connector and ECM harness connector.

| DTC   | A/F sensor 1 |           |          | ECM       |          | Continuity |
|-------|--------------|-----------|----------|-----------|----------|------------|
|       | Bank         | Connector | Terminal | Connector | Terminal |            |
| P0130 | 1            | F23       | 6        | F111      | 94       | Existed    |
| P0150 | 2            | F24       | 6        |           | 74       |            |

4. Also check harness for short to power.

Is the inspection result normal?

# P0130, P0150 A/F SENSOR 1

[VK56VD FOR MEXICO]

< DTC/CIRCUIT DIAGNOSIS >

YES >> GO TO 4.

NO >> Repair open circuit, short to ground or short to power in harness or connectors.

A

## 4.CHECK INTERMITTENT INCIDENT

Perform [GI-44. "Intermittent Incident"](#).

Is the inspection result normal?

YES >> GO TO 5.

NO >> Repair or replace malfunctioning part.

EC

C

## 5.REPLACE A/F SENSOR 1

Replace malfunctioning A/F sensor 1. Refer to [EM-223. "Exploded View"](#).

### **CAUTION:**

- Discard any A/F sensor which has been dropped from a height of more than 0.5 m (19.7 in) onto a hard surface such as a concrete floor; use a new one.
- Before installing new A/F sensor, clean exhaust system threads using Oxygen Sensor Thread Cleaner [commercial service tool (J-43897-18 or J-43897-12)] and approved anti-seize lubricant (commercial service tool).

D

E

>> INSPECTION END

F

G

H

I

J

K

L

M

N

O

P

P0131, P0151 A/F SENSOR 1

DTC Logic

INFOID:000000007758281

DTC DETECTION LOGIC

To judge the malfunction, the diagnosis checks that the A/F signal computed by ECM from the A/F sensor 1 signal is not inordinately low.

| DTC No. | Trouble diagnosis name<br>(Trouble diagnosis content)                               | DTC detecting condition  | Possible Cause   |
|---------|---|--|--|
| P0131   | A/F SENSOR1 (B1)<br>[Air fuel ratio (A/F) sensor 1<br>(bank 1) circuit low voltage] | <ul style="list-style-type: none"> <li>The A/F signal computed by ECM from the A/F sensor 1 signal is constantly approx. 0 V.</li> </ul> | <ul style="list-style-type: none"> <li>Harness or connectors<br/>(The A/F sensor 1 circuit is open or shorted.)</li> <li>A/F sensor 1</li> </ul> |
| P0151   | A/F SENSOR1 (B2)<br>[Air fuel ratio (A/F) sensor 1<br>(bank 2) circuit low voltage] |  |  |

DTC CONFIRMATION PROCEDURE

1. PRECONDITIONING

- Turn ignition switch OFF and wait at least 10 seconds.
- Turn ignition switch ON.
- Turn ignition switch OFF and wait at least 10 seconds.

**TESTING CONDITION:**

Before performing the following procedure, confirm that battery voltage is 10.5 V or more at idle.

>> GO TO 2.

2. CHECK A/F SENSOR FUNCTION

 WITH CONSULT

- Start engine and warm it up to normal operating temperature.
- Select "A/F SEN1 (B1)" or "A/F SEN1 (B2)" in "DATA MONITOR" mode with CONSULT.
- Check "A/F SEN1 (B1)" or "A/F SEN1 (B2)" indication.

 WITH GST

Follow the procedure "With CONSULT" above.

Is the indication constantly approx. 0 V?

- YES >> Proceed to [EC-1769. "Diagnosis Procedure"](#).  
 NO >> GO TO 3.

3. PERFORM DTC CONFIRMATION PROCEDURE

 WITH CONSULT

- Turn ignition switch OFF and wait at least 10 seconds.
- Turn ignition switch ON.
- Turn ignition switch OFF and wait at least 10 seconds.
- Restart engine.
- Drive and accelerate vehicle to more than 40 km/h (25 MPH) within 20 seconds after restarting engine.

**CAUTION:**

**Always drive vehicle at a safe speed.**

- Maintain the following conditions for approximately 20 consecutive seconds.

|                |                            |
|----------------|----------------------------|
| ENG SPEED      | 1,000 - 3,200 rpm          |
| VHCL SPEED SE  | More than 40 km/h (25 mph) |
| B/FUEL SCHDL   | 1.5 - 9.0 msec             |
| Selector lever | Suitable position          |

**NOTE:**

- Keep the accelerator pedal as steady as possible during cruising.



# P0131, P0151 A/F SENSOR 1

[VK56VD FOR MEXICO]

## < DTC/CIRCUIT DIAGNOSIS >

- If this procedure is not completed within 1 minute after restarting engine at step 1, return to step 1.

7. Check 1st trip DTC.

 WITH GST

Follow the procedure "With CONSULT" above.

Is 1st trip DTC detected?

- YES >> Proceed to [EC-1769, "Diagnosis Procedure"](#).  
NO >> INSPECTION END

## Diagnosis Procedure

INFOID:000000007758282

### 1. CHECK AIR FUEL RATIO SENSOR 1 POWER SUPPLY CIRCUIT

1. Disconnect air fuel ratio (A/F) sensor 1 harness connector.
2. Turn ignition switch ON.
3. Check the voltage between A/F sensor 1 harness connector and ground.

| DTC   | A/F sensor 1 |           |          | Ground | Voltage |
|-------|--------------|-----------|----------|--------|---------|
|       | Bank         | Connector | Terminal |        |         |
| P0131 | 1            | F23       | 4        | Ground | 3.0 V   |
| P0151 | 2            | F24       | 4        |        |         |

Is the inspection result normal?

- YES >> GO TO 2.  
NO >> Repair open circuit, short to ground or short to power in harness or connectors.

### 2. CHECK A/F SENSOR 1 INPUT SIGNAL CIRCUIT FOR OPEN AND SHORT

1. Turn ignition switch OFF.
2. Disconnect ECM harness connector.
3. Check the continuity between A/F sensor 1 harness connector and ECM harness connector.

| DTC   | A/F sensor 1 |           |          | ECM       |          | Continuity |
|-------|--------------|-----------|----------|-----------|----------|------------|
|       | Bank         | Connector | Terminal | Connector | Terminal |            |
| P0131 | 1            | F23       | 3        | F111      | 88       | Existed    |
| P0151 | 2            | F24       | 3        |           | 78       |            |

4. Check the continuity between A/F sensor 1 harness connector and ground, or ECM harness connector and ground.

| DTC   | A/F sensor 1 |           |          | ECM       |          | Ground | Continuity  |
|-------|--------------|-----------|----------|-----------|----------|--------|-------------|
|       | Bank         | Connector | Terminal | Connector | Terminal |        |             |
| P0131 | 1            | F23       | 3        | F111      | 88       | Ground | Not existed |
| P0151 | 2            | F24       | 3        |           | 78       |        |             |

5. Also check harness for short to power.

Is the inspection result normal?

- YES >> GO TO 3.  
NO >> Repair open circuit, short to ground or short to power in harness or connectors.

### 3. CHECK A/F SENSOR 1 GROUND CIRCUIT FOR OPEN AND SHORT

1. Turn ignition switch OFF.
2. Disconnect ECM harness connector.
3. Check the continuity between A/F sensor 1 harness connector and ECM harness connector.

# P0131, P0151 A/F SENSOR 1

< DTC/CIRCUIT DIAGNOSIS >

[VK56VD FOR MEXICO]

| DTC   | A/F sensor 1 |           |          | ECM       |          | Continuity |
|-------|--------------|-----------|----------|-----------|----------|------------|
|       | Bank         | Connector | Terminal | Connector | Terminal |            |
| P0131 | 1            | F23       | 6        | F111      | 94       | Existed    |
| P0151 | 2            | F24       | 6        |           | 74       |            |

4. Also check harness for short to power.

Is the inspection result normal?

YES >> GO TO 4.

NO >> Repair open circuit, short to ground or short to power in harness or connectors.

## 4.CHECK INTERMITTENT INCIDENT

Perform [GI-44. "Intermittent Incident"](#).

Is the inspection result normal?

YES >> GO TO 5.

NO >> Repair or replace malfunctioning part.

## 5.REPLACE A/F SENSOR 1

Replace malfunctioning A/F sensor 1. Refer to [EM-223. "Exploded View"](#).

### CAUTION:

- Discard any A/F sensor which has been dropped from a height of more than 0.5 m (19.7 in) onto a hard surface such as a concrete floor; use a new one.
- Before installing new A/F sensor, clean exhaust system threads using Oxygen Sensor Thread Cleaner [commercial service tool (J-43897-18 or J-43897-12)] and approved anti-seize lubricant (commercial service tool).

>> INSPECTION END

P0132, P0152 A/F SENSOR 1

DTC Logic

INFOID:000000007758283

DTC DETECTION LOGIC

To judge the malfunction, the diagnosis checks that the A/F signal computed by ECM from the A/F sensor 1 signal is not inordinately high.

| DTC No. | Trouble diagnosis name<br>(Trouble diagnosis content)                                | DTC detecting condition   | Possible Cause   |
|---------|--|---|--|
| P0132   | A/F SENSOR1 (B1)<br>[Air fuel ratio (A/F) sensor 1<br>(bank 1) circuit high voltage] | • The A/F signal computed by ECM from the<br>A/F sensor 1 signal is constantly approx. 5 V. | <ul style="list-style-type: none"> <li>• Harness or connectors<br/>(The A/F sensor 1 circuit is open or<br/>shorted.)</li> <li>• A/F sensor 1</li> </ul> |
| P0152   | A/F SENSOR1 (B2)<br>[Air fuel ratio (A/F) sensor 1<br>(bank 2) circuit high voltage] |   |  |

DTC CONFIRMATION PROCEDURE

1. PRECONDITIONING

1. Turn ignition switch OFF and wait at least 10 seconds.
2. Turn ignition switch ON.
3. Turn ignition switch OFF and wait at least 10 seconds.

**TESTING CONDITION:**

**Before performing the following procedure, confirm that battery voltage is 10.5 V or more at idle.**

>> GO TO 2.

2. CHECK A/F SENSOR FUNCTION

 WITH CONSULT

1. Start engine and warm it up to normal operating temperature.
2. Select "A/F SEN1 (B1)" or "A/F SEN1 (B2)" in "DATA MONITOR" mode with CONSULT.
3. Check "A/F SEN1 (B1)" or "A/F SEN1 (B2)" indication.

 WITH GST

Follow the procedure "With CONSULT" above.

Is the indication constantly approx. 5 V?

- YES >> Proceed to [EC-1772. "Diagnosis Procedure"](#).  
 NO >> GO TO 3.

3. PERFORM DTC CONFIRMATION PROCEDURE

 WITH CONSULT

1. Turn ignition switch OFF and wait at least 10 seconds.
2. Turn ignition switch ON.
3. Turn ignition switch OFF and wait at least 10 seconds.
4. Restart engine.
5. Drive and accelerate vehicle to more than 40 km/h (25 MPH) within 20 seconds after restarting engine.

**CAUTION:**

**Always drive vehicle at a safe speed.**

6. Maintain the following conditions for approximately 20 consecutive seconds.

|                |                            |
|----------------|----------------------------|
| ENG SPEED      | 1,000 - 3,200 rpm          |
| VHCL SPEED SE  | More than 40 km/h (25 mph) |
| B/FUEL SCHDL   | 1.5 - 9.0 msec             |
| Selector lever | Suitable position          |

**NOTE:**

- Keep the accelerator pedal as steady as possible during cruising.

# P0132, P0152 A/F SENSOR 1

[VK56VD FOR MEXICO]

## < DTC/CIRCUIT DIAGNOSIS >

- If this procedure is not completed within 1 minute after restarting engine at step 1, return to step 1.

7. Check 1st trip DTC.

 WITH GST

Follow the procedure "With CONSULT" above.

Is 1st trip DTC detected?

- YES >> Proceed to [EC-1772, "Diagnosis Procedure"](#).  
NO >> INSPECTION END

## Diagnosis Procedure

INFOID:000000007758284

### 1. CHECK AIR FUEL RATIO SENSOR 1 POWER SUPPLY CIRCUIT

1. Disconnect air fuel ratio (A/F) sensor 1 harness connector.
2. Turn ignition switch ON.
3. Check the voltage between A/F sensor 1 harness connector and ground.

| DTC   | A/F sensor 1 |           |          | Ground | Voltage |
|-------|--------------|-----------|----------|--------|---------|
|       | Bank         | Connector | Terminal |        |         |
| P0132 | 1            | F23       | 4        | Ground | 3.0 V   |
| P0152 | 2            | F24       | 4        |        |         |

Is the inspection result normal?

- YES >> GO TO 2.  
NO >> Repair open circuit, short to ground or short to power in harness or connectors.

### 2. CHECK A/F SENSOR 1 INPUT SIGNAL CIRCUIT FOR OPEN AND SHORT

1. Turn ignition switch OFF.
2. Disconnect ECM harness connector.
3. Check the continuity between A/F sensor 1 harness connector and ECM harness connector.

| DTC   | A/F sensor 1 |           |          | ECM       |          | Continuity |
|-------|--------------|-----------|----------|-----------|----------|------------|
|       | Bank         | Connector | Terminal | Connector | Terminal |            |
| P0132 | 1            | F23       | 3        | F111      | 88       | Existed    |
| P0152 | 2            | F24       | 3        |           | 78       |            |

4. Check the continuity between A/F sensor 1 harness connector and ground, or ECM harness connector and ground.

| DTC   | A/F sensor 1 |           |          | ECM       |          | Ground | Continuity  |
|-------|--------------|-----------|----------|-----------|----------|--------|-------------|
|       | Bank         | Connector | Terminal | Connector | Terminal |        |             |
| P0132 | 1            | F23       | 3        | F111      | 88       | Ground | Not existed |
| P0152 | 2            | F24       | 3        |           | 78       |        |             |

5. Also check harness for short to power.

Is the inspection result normal?

- YES >> GO TO 3.  
NO >> Repair open circuit, short to ground or short to power in harness or connectors.

### 3. CHECK A/F SENSOR 1 GROUND CIRCUIT FOR OPEN AND SHORT

1. Turn ignition switch OFF.
2. Disconnect ECM harness connector.
3. Check the continuity between A/F sensor 1 harness connector and ECM harness connector.

# P0132, P0152 A/F SENSOR 1

< DTC/CIRCUIT DIAGNOSIS >

[VK56VD FOR MEXICO]

| DTC   | A/F sensor 1 |           |          | ECM       |          | Continuity |
|-------|--------------|-----------|----------|-----------|----------|------------|
|       | Bank         | Connector | Terminal | Connector | Terminal |            |
| P0132 | 1            | F23       | 6        | F111      | 94       | Existed    |
| P0152 | 2            | F24       | 6        |           | 74       |            |

4. Also check harness for short to power.

Is the inspection result normal?

YES >> GO TO 4.

NO >> Repair open circuit, short to ground or short to power in harness or connectors.

## 4.CHECK INTERMITTENT INCIDENT

Perform [GI-44, "Intermittent Incident"](#).

Is the inspection result normal?

YES >> GO TO 5.

NO >> Repair or replace malfunctioning part.

## 5.REPLACE A/F SENSOR 1

Replace malfunctioning A/F sensor 1. Refer to [EM-223, "Exploded View"](#).

### CAUTION:

- Discard any A/F sensor which has been dropped from a height of more than 0.5 m (19.7 in) onto a hard surface such as a concrete floor; use a new one.
- Before installing new A/F sensor, clean exhaust system threads using Oxygen Sensor Thread Cleaner [commercial service tool (J-43897-18 or J-43897-12)] and approved anti-seize lubricant (commercial service tool).

>> INSPECTION END

A  
EC  
C  
D  
E  
F  
G  
H  
I  
J  
K  
L  
M  
N  
O  
P

P0133, P0153 A/F SENSOR 1

DTC Logic

INFOID:000000007758285

DTC DETECTION LOGIC

To judge the malfunction of A/F sensor 1, this diagnosis measures response time of the A/F signal computed by ECM from the A/F sensor 1 signal. The time is compensated by engine operating (speed and load), fuel feedback control constant, and the A/F sensor 1 temperature index. Judgment is based on whether the compensated time (the A/F signal cycling time index) is inordinately long or not.

| DTC No. | Trouble diagnosis name<br>(Trouble diagnosis content)                                 | DTC detecting condition   | Possible Cause  |
|---------|---|---|---|
| P0133   | A/F SENSOR1 (B1)<br>[Air fuel ratio (A/F) sensor 1<br>(bank 1) circuit slow response] | <ul style="list-style-type: none"> <li>The response of the A/F signal computed by ECM from A/F sensor 1 signal takes more than the specified time.</li> </ul> | <ul style="list-style-type: none"> <li>Harness or connectors<br/>(The A/F sensor 1 circuit is open or shorted.)</li> <li>A/F sensor 1</li> <li>A/F sensor 1 heater</li> <li>Fuel pressure</li> <li>Fuel injector</li> <li>Intake air leaks</li> <li>Exhaust gas leaks</li> <li>PCV</li> <li>Mass air flow sensor</li> </ul> |
| P0153   | A/F SENSOR1 (B2)<br>[Air fuel ratio (A/F) sensor 1<br>(bank 2) circuit slow response] |   |   |

DTC CONFIRMATION PROCEDURE

1. PRECONDITIONING

- Turn ignition switch OFF and wait at least 10 seconds.
- Turn ignition switch ON.
- Turn ignition switch OFF and wait at least 10 seconds.

**TESTING CONDITION:**

**Before performing the following procedure, confirm that battery voltage is 11 V or more at idle.**

Will CONSULT be used?

- YES >> GO TO 2.  
NO >> GO TO 5.

2. PERFORM DTC CONFIRMATION PROCEDURE-I

 WITH CONSULT

- Start engine and warm it up to normal operating temperature.
- Turn ignition switch OFF and wait at least 10 seconds.
- Turn ignition switch ON.
- Turn ignition switch OFF and wait at least 10 seconds.
- Restart engine and keep the engine speed between 3,500 and 4,000 rpm for at least 1 minute under no load.
- Let engine idle for 1 minute.
- Select "A/F SEN1(B1) P1278/P1279" (for DTC P0133) or "A/F SEN1(B2) P1288/P1289" (for DTC P0153) of "A/F SEN1" in "DTC WORK SUPPORT" mode with CONSULT.
- Touch "START".

Is "COMPLETED" displayed on CONSULT screen?

- YES >> GO TO 3  
NO >> GO TO 4.

3. PERFORM DTC CONFIRMATION PROCEDURE-II

Touch "SELF-DIAG RESULT".

Which is displayed on CONSULT screen?

- OK >> INSPECTION END  
NG >> Proceed to [EC-1775. "Diagnosis Procedure"](#).

4. PERFORM DTC CONFIRMATION PROCEDURE-II

< DTC/CIRCUIT DIAGNOSIS >

1. After perform the following procedure, "TESTING" will be displayed on the CONSULT screen.
  - Increase the engine speed up to between 4,000 and 5,000 rpm and maintain that speed for 10 seconds.
  - Fully release accelerator pedal and then let engine idle for approximately 10 seconds.
- If "TESTING" is not displayed after 10 seconds, refer to [EC-1700, "Component Function Check"](#).
2. Wait for approximately 20 seconds at idle under the condition that "TESTING" is displayed on the CONSULT screen.
3. Check that "TESTING" changes to "COMPLETED".
  - If "TESTING" changed to "OUT OF CONDITION", refer to [EC-1700, "Component Function Check"](#).
4. Touch "SELF-DIAG RESULT".

Which is displayed on CONSULT screen?

- OK >> INSPECTION END
- NG >> Proceed to [EC-1775, "Diagnosis Procedure"](#).

5.CHECK AIR-FUEL RATIO SELF-LEARNING VALUE

 WITH GST

1. Start engine and warm it up to normal operating temperature.
2. Select Service \$01 with GST.
3. Calculate the total value of "Short term fuel trim" and "Long term fuel trim" indications.

Is the total percentage within  $\pm 15\%$ ?

- YES >> GO TO 7.
- NO >> GO TO 6.

6.DETECT MALFUNCTIONING PART

Check the following.

- Intake air leaks
- Exhaust gas leaks
- Incorrect fuel pressure
- Lack of fuel
- Fuel injector
- Incorrect PCV hose connection
- PCV valve
- Mass air flow sensor

>> Repair or replace malfunctioning part.

7.PERFORM DTC CONFIRMATION PROCEDURE

1. Turn ignition switch OFF and wait at least 10 seconds.
2. Start engine and keep the engine speed between 3,500 and 4,000 rpm for at least 1 minute under no load.
3. Let engine idle for 1 minute.
4. Increase the engine speed up to between 4,000 and 5,000 rpm and maintain that speed for 10 seconds.
5. Fully release accelerator pedal and then let engine idle for approximately 1 minute.
6. Check 1st trip DTC.

Is 1st trip DTC detected?

- YES >> Proceed to [EC-1775, "Diagnosis Procedure"](#).
- NO >> INSPECTION END

Diagnosis Procedure

INFOID:000000007758286

1.RETIGHTEN AIR FUEL RATIO SENSOR 1

Loosen and retighten the air fuel ratio (A/F) sensor 1. Refer to [EM-223, "Exploded View"](#).

>> GO TO 2.

2.CHECK EXHAUST GAS LEAKAGE

1. Start engine and run it at idle.

# P0133, P0153 A/F SENSOR 1

[VK56VD FOR MEXICO]

## < DTC/CIRCUIT DIAGNOSIS >

- Listen for an exhaust gas leakage before three way catalyst (manifold).

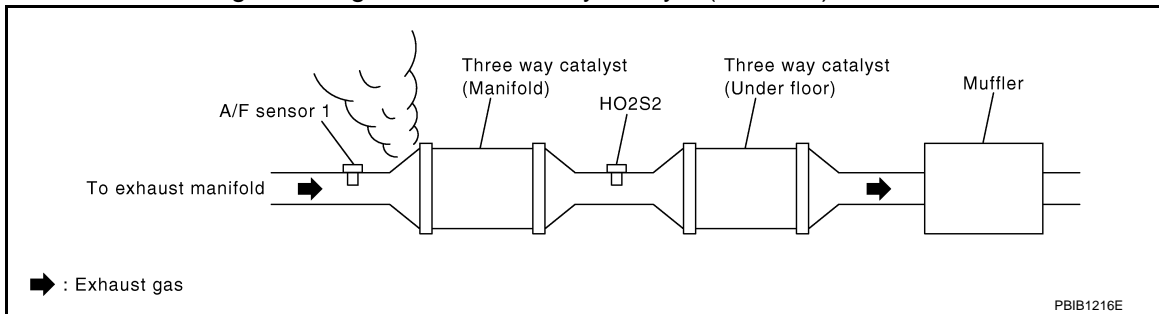

### Is exhaust gas leakage detected?

- YES >> Repair or replace malfunctioning part.
- NO >> GO TO 3.

## 3.CHECK FOR INTAKE AIR LEAKAGE

Listen for an intake air leakage after the mass air flow sensor.

### Is intake air leakage detected?

- YES >> Repair or replace malfunctioning part.
- NO >> GO TO 4.

## 4.CLEAR THE MIXTURE RATIO SELF-LEARNING VALUE

- Clear the mixture ratio self-learning value. Refer to [EC-1691, "Work Procedure"](#).
- Run engine for at least 10 minutes at idle speed.

### Is the 1st trip DTC P0171, P172, P0174 or P0175 detected? Is it difficult to start engine?

- YES >> Perform trouble diagnosis for DTC P0171, P0174 or P0172, P0175. Refer to [EC-1799, "DTC Logic"](#) or [EC-1803, "DTC Logic"](#).
- NO >> GO TO 5.

## 5.CHECK AIR FUEL RATIO SENSOR 1 POWER SUPPLY CIRCUIT

- Disconnect air fuel ratio (A/F) sensor 1 harness connector.
- Turn ignition switch ON.
- Check the voltage between A/F sensor 1 harness connector and ground.

| DTC   | A/F sensor 1 |           |          | Ground | Voltage |
|-------|--------------|-----------|----------|--------|---------|
|       | Bank         | Connector | Terminal |        |         |
| P0133 | 1            | F23       | 4        | Ground | 3.0 V   |
| P0153 | 2            | F24       | 4        |        |         |

### Is the inspection result normal?

- YES >> GO TO 6.
- NO >> Repair open circuit, short to ground or short to power in harness or connectors.

## 6.CHECK A/F SENSOR 1 INPUT SIGNAL CIRCUIT FOR OPEN AND SHORT

- Turn ignition switch OFF.
- Disconnect ECM harness connector.
- Check the continuity between A/F sensor 1 harness connector and ECM harness connector.

| DTC   | A/F sensor 1 |           |          | ECM       |          | Continuity |
|-------|--------------|-----------|----------|-----------|----------|------------|
|       | Bank         | Connector | Terminal | Connector | Terminal |            |
| P0133 | 1            | F23       | 3        | F111      | 88       | Existed    |
| P0153 | 2            | F24       | 3        |           | 78       |            |

- Check the continuity between A/F sensor 1 harness connector and ground, or ECM harness connector and ground.



# P0133, P0153 A/F SENSOR 1

< DTC/CIRCUIT DIAGNOSIS >

[VK56VD FOR MEXICO]

| DTC   | A/F sensor 1 |           |          | ECM       |          | Ground | Continuity  |
|-------|--------------|-----------|----------|-----------|----------|--------|-------------|
|       | Bank         | Connector | Terminal | Connector | Terminal |        |             |
| P0133 | 1            | F23       | 3        | F111      | 88       | Ground | Not existed |
| P0153 | 2            | F24       | 3        |           | 78       |        |             |

5. Also check harness for short to power.

Is the inspection result normal?

YES >> GO TO 7.

NO >> Repair open circuit, short to ground or short to power in harness or connectors.

## 7.CHECK A/F SENSOR 1 GROUND CIRCUIT FOR OPEN AND SHORT

1. Turn ignition switch OFF.
2. Disconnect ECM harness connector.
3. Check the continuity between A/F sensor 1 harness connector and ECM harness connector.

| DTC   | A/F sensor 1 |           |          | ECM       |          | Continuity |
|-------|--------------|-----------|----------|-----------|----------|------------|
|       | Bank         | Connector | Terminal | Connector | Terminal |            |
| P0133 | 1            | F23       | 6        | F111      | 94       | Existed    |
| P0153 | 2            | F24       | 6        |           | 74       |            |

4. Also check harness for short to power.

Is the inspection result normal?

YES >> GO TO 8.

NO >> Repair open circuit, short to ground or short to power in harness or connectors.

## 8.CHECK A/F SENSOR 1 HEATER

Refer to [EC-1726. "Component Inspection \(A/F Sensor 1 Heater\)".](#)

Is the inspection result normal?

YES >> GO TO 9.

NO >> GO TO 12.

## 9.CHECK MASS AIR FLOW SENSOR

Check both mass air flow sensor (bank 1) and mass air flow sensor (bank 2).

Refer to [EC-1751. "Component Inspection \(MAF Sensor\)".](#)

Is the inspection result normal?

YES >> GO TO 10.

NO >> Replace malfunctioning mass air flow sensor. Refer to [EM-184. "Removal and Installation".](#)

## 10.CHECK PCV VALVE

Refer to [EC-2012. "Inspection".](#)

Is the inspection result normal?

YES >> GO TO 11.

NO >> Repair or replace PCV valve. Refer to [EM-186. "Exploded View".](#)

## 11.CHECK INTERMITTENT INCIDENT

Perform [GI-44. "Intermittent Incident".](#)

Is the inspection result normal?

YES >> GO TO 12.

NO >> Repair or replace malfunctioning part.

## 12.REPLACE A/F SENSOR 1

Replace malfunctioning A/F sensor 1. Refer to [EM-223. "Exploded View".](#)

### CAUTION:

- Discard any A/F sensor which has been dropped from a height of more than 0.5 m (19.7 in) onto a hard surface such as a concrete floor; use a new one.

## P0133, P0153 A/F SENSOR 1

< DTC/CIRCUIT DIAGNOSIS >

[VK56VD FOR MEXICO]

- Before installing new A/F sensor, clean exhaust system threads using Oxygen Sensor Thread Cleaner [commercial service tool (J-43897-18 or J-43897-12)] and approved anti-seize lubricant (commercial service tool).

>> INSPECTION END

P0137, P0157 HO2S2

DTC Logic

INFOID:000000007758287

DTC DETECTION LOGIC

The heated oxygen sensor 2 has a much longer switching time between rich and lean than the air fuel ratio (A/F) sensor 1. The oxygen storage capacity of the three way catalyst (manifold) causes the longer switching time. To judge the malfunctions of heated oxygen sensor 2, ECM monitors whether the maximum voltage of the sensor is sufficiently high during various driving conditions such as fuel cut.

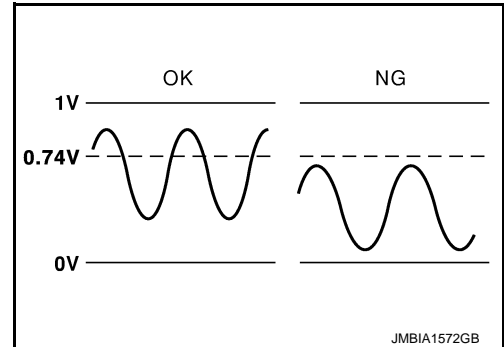

| DTC No. | Trouble diagnosis name (Trouble diagnosis content)                  | DTC detecting condition   | Possible cause  |
|---------|---|---|---|
| P0137   | HO2S2 (B1)<br>[Heated oxygen sensor 2 (bank 1) circuit low voltage] | The maximum voltage from the sensor does not reach the specified voltage. | <ul style="list-style-type: none"> <li>• Harness or connectors (The heated oxygen sensor 2 circuit is open or shorted)</li> <li>• Heated oxygen sensor 2</li> <li>• Fuel pressure</li> <li>• Fuel injector</li> <li>• Intake air leaks</li> </ul> |
| P0157   | HO2S2 (B2)<br>[Heated oxygen sensor 2 (bank 2) circuit low voltage] |   |   |

DTC CONFIRMATION PROCEDURE

1. PRECONDITIONING

If DTC Confirmation Procedure has been previously conducted, always perform the following procedure before conducting the next test.

1. Turn ignition switch OFF and wait at least 10 seconds.
2. Turn ignition switch ON.
3. Turn ignition switch OFF and wait at least 10 seconds.

Will CONSULT be used?

- YES >> GO TO 2.
- NO >> GO TO 4.

2. PERFORM DTC CONFIRMATION PROCEDURE

Ⓜ WITH CONSULT

TESTING CONDITION:

For better results, perform "DTC WORK SUPPORT" at a temperature of 0 to 30°C (32 to 86°F).

1. Start engine and warm it up to the normal operating temperature.
2. Turn ignition switch OFF and wait at least 10 seconds.
3. Turn ignition switch ON.
4. Turn ignition switch OFF and wait at least 10 seconds.
5. Restart engine and keep the engine speed between 3,500 and 4,000 rpm for at least 1 minute under no load.
6. Let engine idle for 1 minute.
7. Select "DATA MONITOR" mode with CONSULT.
8. Check that "COOLAN TEMP/S" indicates more than 70°C (158°F).  
If not, warm up engine and go to next step when "COOLAN TEMP/S" indication reaches 70°C (158°F).
9. Open engine hood.
10. Select "HO2S2 (B1) P1147" (for DTC P0137) or "HO2S2 (B2) P1167" (for DTC P0157) of "HO2S2" in "DTC WORK SUPPORT" mode with CONSULT.
11. Follow the instruction of CONSULT display.

NOTE:

< DTC/CIRCUIT DIAGNOSIS >

It will take at most 10 minutes until "COMPLETED" is displayed.

12. Touch "SELF-DIAG RESULTS".

Which is displayed on CONSULT screen?

- OK >> INSPECTION END
- NG >> Proceed to [EC-1781, "Diagnosis Procedure"](#).
- CAN NOT BE DIAGNOSED>>GO TO 3.

**3.PERFORM DTC CONFIRMATION PROCEDURE AGAIN**

1. Turn ignition switch OFF and leave the vehicle in a cool place (soak the vehicle).
2. Perform DTC confirmation procedure again.

>> GO TO 2.

**4.PERFORM COMPONENT FUNCTION CHECK**

 WITH GST

Perform component function check. Refer to [EC-1780, "Component Function Check"](#).

**NOTE:**

Use component function check to check the overall function of the heated oxygen sensor 2 circuit. During this check, a 1st trip DTC might not be confirmed.

Is the inspection result normal?

- YES >> INSPECTION END
- NO >> Proceed to [EC-1781, "Diagnosis Procedure"](#).

**Component Function Check**

INFOID:000000007758288

**1.PERFORM COMPONENT FUNCTION CHECK-I**

 With GST

1. Start engine and warm it up to the normal operating temperature.
2. Turn ignition switch OFF and wait at least 10 seconds.
3. Turn ignition switch ON.
4. Turn ignition switch OFF and wait at least 10 seconds.
5. Restart engine and keep the engine speed between 3,500 and 4,000 rpm for at least 1 minute under no load.
6. Let engine idle for 1 minute.
7. Check the voltage between ECM harness connector terminals under the following conditions.

| DTC   | ECM       |          |          | Condition   | Voltage   |
|-------|-----------|----------|----------|---|---|
|       | Connector | +        | -        |   |   |
|       |           | Terminal | Terminal |   |   |
| P0137 | F111      | 96       | 100      | Revving up to 4,000 rpm under no load at least 10 times | The voltage should be above 0.74 V at least once during this procedure. |
| P0157 |           | 87       |          |   |   |

Is the inspection result normal?

- YES >> INSPECTION END
- NO >> GO TO 2.

**2.PERFORM COMPONENT FUNCTION CHECK-II**

Check the voltage between ECM harness connector terminals under the following conditions.

| DTC   | ECM       |          |          | Condition                             | Voltage   |
|-------|-----------|----------|----------|---------------------------------------|---|
|       | Connector | +        | -        |                                       |   |
|       |           | Terminal | Terminal |                                       |   |
| P0137 | F111      | 96       | 100      | Keeping engine at idle for 10 minutes | The voltage should be above 0.74 V at least once during this procedure. |
| P0157 |           | 87       |          |                                       |   |

Is the inspection result normal?

< DTC/CIRCUIT DIAGNOSIS >

YES >> INSPECTION END  
 NO >> GO TO 3.

**3.PERFORM COMPONENT FUNCTION CHECK-III**

Check the voltage between ECM harness connector terminals under the following conditions.

| DTC   | ECM       |          |          | Condition  | Voltage   |
|-------|-----------|----------|----------|--|---|
|       | Connector | +        | -        |  |   |
|       |           | Terminal | Terminal |  |   |
| P0137 | F111      | 96       | 100      | Coasting from 80 km/h (50 MPH) with selector lever in the D position | The voltage should be above 0.74 V at least once during this procedure. |
| P0157 |           | 87       |          |  |   |

Is the inspection result normal?

YES >> INSPECTION END  
 NO >> Proceed to [EC-1781, "Diagnosis Procedure"](#).

**Diagnosis Procedure**

INFOID:000000007758289

**1.CLEAR THE MIXTURE RATIO SELF-LEARNING VALUE**

1. Clear the mixture ratio self-learning value. Refer to [EC-1691, "Work Procedure"](#).
2. Run engine for at least 10 minutes at idle speed.

Is the 1st trip DTC P0171 or P0174 detected? Is it difficult to start engine?

YES >> Perform trouble diagnosis for DTC P0171 or P0174. Refer to [EC-1799, "DTC Logic"](#).  
 NO >> GO TO 2.

**2.CHECK HEATED OXYGEN SENSOR 2 GROUND CIRCUIT FOR OPEN AND SHORT**

1. Turn ignition switch OFF.
2. Disconnect heated oxygen sensor 2 (HO2S2) harness connector.
3. Disconnect ECM harness connector.
4. Check the continuity between HO2S2 harness connector and ECM harness connector.

| DTC   | HO2S2 |           |          | ECM       |          | Continuity |
|-------|-------|-----------|----------|-----------|----------|------------|
|       | Bank  | Connector | Terminal | Connector | Terminal |            |
| P0137 | 1     | F87       | 1        | F111      | 100      | Existed    |
| P0157 | 2     | F88       | 1        |           |          |            |

5. Also check harness for short to ground and short to power.

Is the inspection result normal?

YES >> GO TO 3.  
 NO >> Repair open circuit, short to ground or short to power in harness or connectors.

**3.CHECK HO2S2 INPUT SIGNAL CIRCUIT FOR OPEN AND SHORT**

1. Check the continuity between HO2S2 harness connector and ECM harness connector.

| DTC   | HO2S2 |           |          | ECM       |          | Continuity |
|-------|-------|-----------|----------|-----------|----------|------------|
|       | Bank  | Connector | Terminal | Connector | Terminal |            |
| P0137 | 1     | F87       | 4        | F111      | 96       | Existed    |
| P0157 | 2     | F88       | 4        |           | 87       |            |

2. Check the continuity between HO2S2 harness connector and ground, or ECM harness connector and ground.

| DTC   | HO2S2 |           |          | ECM       |          | Ground | Continuity  |
|-------|-------|-----------|----------|-----------|----------|--------|-------------|
|       | Bank  | Connector | Terminal | Connector | Terminal |        |             |
| P0137 | 1     | F87       | 4        | F111      | 96       | Ground | Not existed |
| P0157 | 2     | F88       | 4        |           | 87       |        |             |

3. Also check harness for short to power.

Is the inspection result normal?

YES >> GO TO 4.

NO >> Repair open circuit, short to ground or short to power in harness or connectors.

#### 4.CHECK HEATED OXYGEN SENSOR 2

Refer to [EC-1782, "Component Inspection \(HO2 sensor 2\)"](#).

Is the inspection result normal?

YES >> GO TO 6.

NO >> GO TO 5.

#### 5.REPLACE HEATED OXYGEN SENSOR 2

Replace malfunctioning heated oxygen sensor 2. Refer to [EM-223, "Exploded View"](#).

**CAUTION:**

- Discard any heated oxygen sensor which has been dropped from a height of more than 0.5 m (19.7 in) onto a hard surface such as a concrete floor; use a new one.
- Before installing new oxygen sensor, clean exhaust system threads using Oxygen Sensor Thread Cleaner [commercial service tool (J-43897-18 or J-43897-12)] and approved anti-seize lubricant (commercial service tool).

>> INSPECTION END

#### 6.CHECK INTERMITTENT INCIDENT

Refer to [GI-44, "Intermittent Incident"](#).

>> INSPECTION END

### Component Inspection (HO2 sensor 2)

INFOID:000000007758290

#### 1.INSPECTION START

Will CONSULT be used?

Will CONSULT be used?

YES >> GO TO 2.

NO >> GO TO 3.

#### 2.CHECK HEATED OXYGEN SENSOR 2

 WITH CONSULT

1. Start engine and warm it up to the normal operating temperature.
2. Start engine and keep the engine speed between 3,500 and 4,000 rpm for at least 1 minute under no load.
3. Let engine idle for 1 minute.
4. Select "FUEL INJECTION" in "ACTIVE TEST" mode, and select "HO2S2 (B1)/(B2)" as the monitor item with CONSULT.

5. Check "HO2S2 (B1)/(B2)" at idle speed when adjusting "FUEL INJECTION" to ±25%.

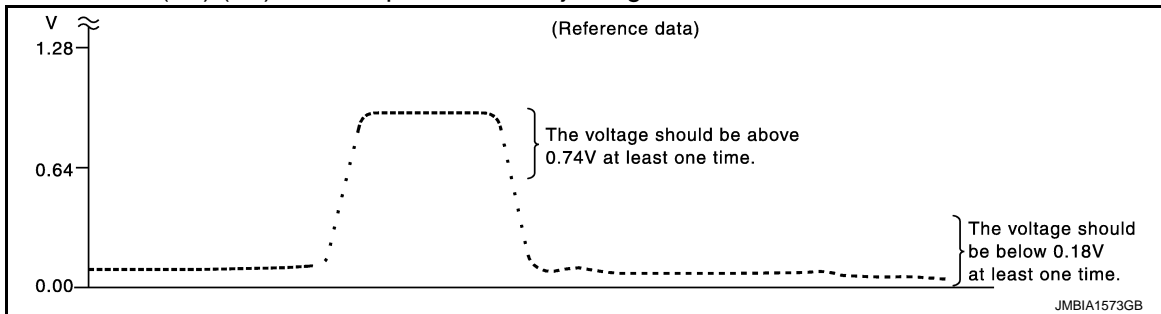

"HO2S2 (B1)/(B2)" should be above 0.74 V at least once when the "FUEL INJECTION" is +25%.  
 "HO2S2 (B1)/(B2)" should be below 0.18 V at least once when the "FUEL INJECTION" is -25%.

Is the inspection result normal?

- YES >> INSPECTION END
- NO >> GO TO 6.

**3.CHECK HEATED OXYGEN SENSOR 2-I**

WITHOUT CONSULT

1. Start engine and warm it up to the normal operating temperature.
2. Turn ignition switch OFF and wait at least 10 seconds.
3. Start engine and keep the engine speed between 3,500 and 4,000 rpm for at least 1 minute under no load.
4. Let engine idle for 1 minute.
5. Check the voltage between ECM harness connector terminals under the following conditions.

| Connector | ECM                       |          | Condition  | Voltage  |
|-----------|---------------------------|----------|--|--|
|           | +                         | -        |  |  |
|           | Terminal                  | Terminal |  |  |
| F111      | 96<br>[HO2S2<br>(bank 1)] | 100      | Reving up to 4,000 rpm under no load at least 10 times | The voltage should be above 0.74 V at least once during this procedure.<br>The voltage should be below 0.18 V at least once during this procedure. |
|           | 87<br>[HO2S2<br>(bank 2)] |          |  |  |

Is the inspection result normal?

- YES >> INSPECTION END
- NO >> GO TO 4.

**4.CHECK HEATED OXYGEN SENSOR 2-II**

Check the voltage between ECM harness connector terminals under the following conditions.

| Connector | ECM                       |          | Condition                             | Voltage  |
|-----------|---------------------------|----------|---------------------------------------|--|
|           | +                         | -        |                                       |  |
|           | Terminal                  | Terminal |                                       |  |
| F111      | 96<br>[HO2S2<br>(bank 1)] | 100      | Keeping engine at idle for 10 minutes | The voltage should be above 0.74 V at least once during this procedure.<br>The voltage should be below 0.18 V at least once during this procedure. |
|           | 87<br>[HO2S2<br>(bank 2)] |          |                                       |  |

Is the inspection result normal?

- YES >> INSPECTION END
- NO >> GO TO 5.

**5.CHECK HEATED OXYGEN SENSOR 2-III**

Check the voltage between ECM harness connector terminals under the following conditions.

# P0137, P0157 HO2S2

< DTC/CIRCUIT DIAGNOSIS >

[VK56VD FOR MEXICO]

| ECM       |                           |          | Condition  | Voltage  |
|-----------|---------------------------|----------|--|--|
| Connector | +                         | -        |  |  |
|           | Terminal                  | Terminal |  |  |
| F111      | 96<br>[HO2S2<br>(bank 1)] | 100      | Coasting from 80 km/h (50 MPH) with selector lever in the D position | The voltage should be above 0.74 V at least once during this procedure.<br>The voltage should be below 0.18 V at least once during this procedure. |
|           | 87<br>[HO2S2<br>(bank 2)] |          |  |  |

Is the inspection result normal?

YES >> INSPECTION END

NO >> GO TO 6.

## 6. REPLACE HEATED OXYGEN SENSOR 2

Replace malfunctioning heated oxygen sensor 2. Refer to [EM-223. "Exploded View"](#).

**CAUTION:**

- Discard any heated oxygen sensor which has been dropped from a height of more than 0.5 m (19.7 in) onto a hard surface such as a concrete floor; use a new one.
- Before installing new oxygen sensor, clean exhaust system threads using Oxygen Sensor Thread Cleaner [commercial service tool (J-43897-18 or J-43897-12)] and approved anti-seize lubricant (commercial service tool).

>> INSPECTION END



P0138, P0158 HO2S2

DTC Logic

INFOID:000000007758291

DTC DETECTION LOGIC

The heated oxygen sensor 2 has a much longer switching time between rich and lean than the air fuel ratio (A/F) sensor 1. The oxygen storage capacity of the three way catalyst (manifold) causes the longer switching time.

**MALFUNCTION A**

To judge the malfunctions of heated oxygen sensor 2, ECM monitors whether the voltage is unusually high during various driving conditions such as fuel cut.

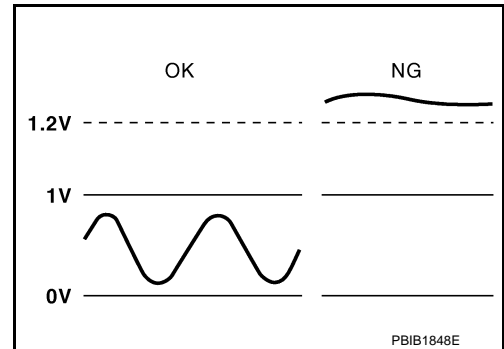

**MALFUNCTION B**

To judge the malfunctions of heated oxygen sensor 2, ECM monitors whether the minimum voltage of sensor is sufficiently low during various driving conditions such as fuel cut.

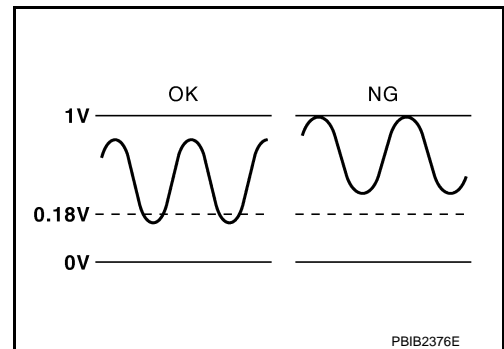

| DTC No. | Trouble diagnosis name<br>(Trouble diagnosis content)                   | DTC detecting condition |  | Possible cause   |
|---------|---|-------------------------|--|--|
| P0138   | HO2S2 (B1)<br>[Heated oxygen sensor 2<br>(bank 1) circuit high voltage] | A)                      | An excessively high voltage from the sensor is sent to ECM.                  | <ul style="list-style-type: none"> <li>• Harness or connectors (The heated oxygen sensor 2 (bank 1) circuit is open or shorted)</li> <li>• Heated oxygen sensor 2</li> </ul>   |
|         |   | B)                      | The minimum voltage from the sensor is not reached to the specified voltage. | <ul style="list-style-type: none"> <li>• Harness or connectors (The heated oxygen sensor 2 (bank 1) circuit is open or shorted)</li> <li>• Heated oxygen sensor 2</li> <li>• Fuel pressure</li> <li>• Fuel injector</li> </ul> |
| P0158   | HO2S2 (B2)<br>[Heated oxygen sensor 2<br>(bank 2) circuit high voltage] | A)                      | An excessively high voltage from the sensor is sent to ECM.                  | <ul style="list-style-type: none"> <li>• Harness or connectors (The heated oxygen sensor 2 (bank 2) circuit is open or shorted)</li> <li>• Heated oxygen sensor 2</li> </ul>   |
|         |   | B)                      | The minimum voltage from the sensor is not reached to the specified voltage. | <ul style="list-style-type: none"> <li>• Harness or connectors (The heated oxygen sensor 2 (bank 2) circuit is open or shorted)</li> <li>• Heated oxygen sensor 2</li> <li>• Fuel pressure</li> <li>• Fuel injector</li> </ul> |

DTC CONFIRMATION PROCEDURE

A  
EC  
C  
D  
E  
F  
G  
H  
I  
J  
K  
L  
M  
N  
O  
P

## &lt; DTC/CIRCUIT DIAGNOSIS &gt;

**1. PRECONDITIONING**

If DTC Confirmation Procedure has been previously conducted, always perform the following procedure before conducting the next test.

1. Turn ignition switch OFF and wait at least 10 seconds.
2. Turn ignition switch ON.
3. Turn ignition switch OFF and wait at least 10 seconds.

>> GO TO 2.

**2. PERFORM DTC CONFIRMATION PROCEDURE FOR MALFUNCTION A**

1. Start engine and warm it up to the normal operating temperature.
2. Turn ignition switch OFF and wait at least 10 seconds.
3. Turn ignition switch ON.
4. Turn ignition switch OFF and wait at least 10 seconds.
5. Start engine and keep the engine speed between 3,500 and 4,000 rpm for at least 1 minute under no load.
6. Let engine idle for 2 minutes.
7. Check 1st trip DTC.

Is 1st trip DTC detected?

YES >> Proceed to [EC-1788. "Diagnosis Procedure"](#).

NO-1 >> With CONSULT: GO TO 3.

NO-2 >> With GST: GO TO 5.

**3. PERFORM DTC CONFIRMATION PROCEDURE FOR MALFUNCTION B**

 WITH CONSULT

**NOTE:**

**For better results, perform "DTC WORK SUPPORT" at a temperature of 0 to 30°C (32 to 86°F).**

1. Start engine and warm it up to the normal operating temperature.
2. Turn ignition switch OFF and wait at least 10 seconds.
3. Turn ignition switch ON.
4. Turn ignition switch OFF and wait at least 10 seconds.
5. Start engine and keep the engine speed between 3,500 and 4,000 rpm for at least 1 minute under no load.
6. Let engine idle for 1 minute.
7. Select "DATA MONITOR" mode with CONSULT.
8. Check that "COOLAN TEMP/S" indicates more than 70°C (158°F).  
If not, warm up engine and go to next step when "COOLAN TEMP/S" indication reaches 70°C (158°F).
9. Open engine hood.
10. Select "HO2S2 (B1) P1146" (for DTC P0138) or "HO2S2 (B2) P1166" (for DTC P0158) of "HO2S2" in "DTC WORK SUPPORT" mode with CONSULT.
11. Follow the instruction of CONSULT display.

**NOTE:**

It will take at most 10 minutes until "COMPLETED" is displayed.

12. Touch "SELF-DIAG RESULTS".

Which is displayed on CONSULT screen?

OK >> INSPECTION END

NG >> Proceed to [EC-1788. "Diagnosis Procedure"](#).

CON NOT BE DIAGNOSED>>GO TO 4.

**4. PERFORM DTC CONFIRMATION PROCEDURE FOR MALFUNCTION B AGAIN**

1. Turn ignition switch OFF and leave the vehicle in a cool place (soak the vehicle).
2. Perform DTC confirmation procedure again.

>> GO TO 3.

**5. PERFORM COMPONENT FUNCTION CHECK FOR MALFUNCTION B**

 WITH GST

Perform component function check. Refer to [EC-1787. "Component Function Check"](#).

**NOTE:**

< DTC/CIRCUIT DIAGNOSIS >

Use component function check to check the overall function of the heated oxygen sensor 2 circuit. During this check, a 1st trip DTC might not be confirmed.

Is the inspection result normal?

- YES >> INSPECTION END
- NO >> Proceed to [EC-1788, "Diagnosis Procedure"](#).

Component Function Check

INFOID:000000007758292

1.PERFORM COMPONENT FUNCTION CHECK-I

 With GST

1. Start engine and warm it up to the normal operating temperature.
2. Turn ignition switch OFF and wait at least 10 seconds.
3. Turn ignition switch ON.
4. Turn ignition switch OFF and wait at least 10 seconds.
5. Start engine and keep the engine speed between 3,500 and 4,000 rpm for at least 1 minute under no load.
6. Let engine idle for 1 minute.
7. Check the voltage between ECM harness connector terminals under the following conditions.

| DTC   | Connector | ECM      |          | Condition   | Voltage   |
|-------|-----------|----------|----------|---|---|
|       |           | +        | -        |   |   |
|       |           | Terminal | Terminal |   |   |
| P0138 | F111      | 96       | 100      | Revving up to 4,000 rpm under no load at least 10 times | The voltage should be below 0.18 V at least once during this procedure. |
| P0158 |           | 87       |          |   |   |

Is the inspection result normal?

- YES >> INSPECTION END
- NO >> GO TO 2.

2.PERFORM COMPONENT FUNCTION CHECK-II

Check the voltage between ECM harness connector terminals under the following conditions.

| DTC   | Connector | ECM      |          | Condition                             | Voltage   |
|-------|-----------|----------|----------|---------------------------------------|---|
|       |           | +        | -        |                                       |   |
|       |           | Terminal | Terminal |                                       |   |
| P0138 | F111      | 96       | 100      | Keeping engine at idle for 10 minutes | The voltage should be below 0.18 V at least once during this procedure. |
| P0158 |           | 87       |          |                                       |   |

Is the inspection result normal?

- YES >> INSPECTION END
- NO >> GO TO 3.

3.PERFORM COMPONENT FUNCTION CHECK-III

Check the voltage between ECM harness connector terminals under the following conditions.

| DTC   | Connector | ECM      |          | Condition  | Voltage   |
|-------|-----------|----------|----------|--|---|
|       |           | +        | -        |  |   |
|       |           | Terminal | Terminal |  |   |
| P0138 | F111      | 96       | 100      | Coasting from 80 km/h (50 MPH) with selector lever in the D position | The voltage should be below 0.18 V at least once during this procedure. |
| P0158 |           | 87       |          |  |   |

Is the inspection result normal?

- YES >> INSPECTION END
- NO >> Proceed to [EC-1788, "Diagnosis Procedure"](#).

Diagnosis Procedure

1.INSPECTION START

Confirm the detected malfunction (A or B). Refer to [EC-1785, "DTC Logic"](#).

Which malfunction is detected?

- A >> GO TO 2
- B >> GO TO 8.

2.CHECK HEATED OXYGEN SENSOR 2 CONNECTOR

1. Disconnect heated oxygen sensor 2 (HO2S2) harness connector.
2. Check that water is not inside connectors.

Is the inspection result normal?

- YES >> GO TO 3.
- NO >> Repair or replace harness or connectors.

3.CHECK HO2S2 GROUND CIRCUIT FOR OPEN AND SHORT

1. Disconnect ECM harness connector.
2. Check the continuity between HO2S2 harness connector and ECM harness connector.

| DTC   | HO2S2 |           |          | ECM       |          | Continuity |
|-------|-------|-----------|----------|-----------|----------|------------|
|       | Bank  | Connector | Terminal | Connector | Terminal |            |
| P0138 | 1     | F87       | 1        | F111      | 100      | Existed    |
| P0158 | 2     | F88       | 1        |           |          |            |

3. Also check harness for short to ground and short to power.

Is the inspection result normal?

- YES >> GO TO 4.
- NO >> Repair open circuit, short to ground or short to power in harness or connectors.

4.CHECK HO2S2 INPUT SIGNAL CIRCUIT FOR OPEN AND SHORT

1. Check the continuity between HO2S2 harness connector and ECM harness connector.

| DTC   | HO2S2 |           |          | ECM       |          | Continuity |
|-------|-------|-----------|----------|-----------|----------|------------|
|       | Bank  | Connector | Terminal | Connector | Terminal |            |
| P0138 | 1     | F87       | 4        | F111      | 96       | Existed    |
| P0158 | 2     | F88       | 4        |           | 87       |            |

2. Check the continuity between HO2S2 harness connector and ground, or ECM harness connector and ground.

| DTC   | HO2S2 |           |          | ECM       |          | Ground | Continuity  |
|-------|-------|-----------|----------|-----------|----------|--------|-------------|
|       | Bank  | Connector | Terminal | Connector | Terminal |        |             |
| P0138 | 1     | F87       | 4        | F111      | 96       | Ground | Not existed |
| P0158 | 2     | F88       | 4        |           | 87       |        |             |

3. Also check harness for short to power.

Is the inspection result normal?

- YES >> GO TO 5.
- NO >> Repair open circuit, short to ground or short to power in harness or connectors.

5.CHECK HEATED OXYGEN SENSOR 2

Refer to [EC-1790, "Component Inspection \(HO2 sensor 2\)"](#).

Is the inspection result normal?

- YES >> GO TO 7.
- NO >> GO TO 6.

**6. REPLACE HEATED OXYGEN SENSOR 2**

Replace malfunctioning heated oxygen sensor 2. Refer to [EM-223, "Exploded View"](#).

**CAUTION:**

- Discard any heated oxygen sensor which has been dropped from a height of more than 0.5 m (19.7 in) onto a hard surface such as a concrete floor; use a new one.
- Before installing new oxygen sensor, clean exhaust system threads using Oxygen Sensor Thread Cleaner [commercial service tool (J-43897-18 or J-43897-12)] and approved anti-seize lubricant (commercial service tool).

>> INSPECTION END

**7. CHECK INTERMITTENT INCIDENT**

Refer to [GI-44, "Intermittent Incident"](#).

>> INSPECTION END

**8. CLEAR THE MIXTURE RATIO SELF-LEARNING VALUE**

1. Clear the mixture ratio self-learning value. Refer to [EC-1691, "Work Procedure"](#).
2. Run engine for at least 10 minutes at idle speed.

Is the 1st trip DTC P0172 or P0175 detected? Is it difficult to start engine?

- YES >> Perform trouble diagnosis for DTC P0172, P0175. Refer to [EC-1803, "DTC Logic"](#).
- NO >> GO TO 9.

**9. CHECK HEATED OXYGEN SENSOR 2 GROUND CIRCUIT FOR OPEN AND SHORT**

1. Turn ignition switch OFF.
2. Disconnect heated oxygen sensor 2 (HO2S2) harness connector.
3. Disconnect ECM harness connector.
4. Check the continuity between HO2S2 harness connector and ECM harness connector.

| DTC   | HO2S2 |           |          | ECM       |          | Continuity |
|-------|-------|-----------|----------|-----------|----------|------------|
|       | Bank  | Connector | Terminal | Connector | Terminal |            |
| P0138 | 1     | F87       | 1        | F111      | 100      | Existed    |
| P0158 | 2     | F88       | 1        |           |          |            |

5. Also check harness for short to ground and short to power.

Is the inspection result normal?

- YES >> GO TO 10.
- NO >> Repair open circuit, short to ground or short to power in harness or connectors.

**10. CHECK HO2S2 INPUT SIGNAL CIRCUIT FOR OPEN AND SHORT**

1. Check the continuity between HO2S2 harness connector and ECM harness connector.

| DTC   | HO2S2 |           |          | ECM       |          | Continuity |
|-------|-------|-----------|----------|-----------|----------|------------|
|       | Bank  | Connector | Terminal | Connector | Terminal |            |
| P0138 | 1     | F87       | 4        | F111      | 96       | Existed    |
| P0158 | 2     | F88       | 4        |           | 87       |            |

2. Check the continuity between HO2S2 harness connector and ground, or ECM harness connector and ground.

| DTC   | HO2S2 |           |          | ECM       |          | Ground | Continuity  |
|-------|-------|-----------|----------|-----------|----------|--------|-------------|
|       | Bank  | Connector | Terminal | Connector | Terminal |        |             |
| P0138 | 1     | F87       | 4        | F111      | 96       | Ground | Not existed |
| P0158 | 2     | F88       | 4        |           | 87       |        |             |

< DTC/CIRCUIT DIAGNOSIS >

3. Also check harness for short to power.

Is the inspection result normal?

YES >> GO TO 11.

NO >> Repair open circuit, short to ground or short to power in harness or connectors.

**11. CHECK HEATED OXYGEN SENSOR 2**

Refer to [EC-1790, "Component Inspection \(HO2 sensor 2\)"](#).

Is the inspection result normal?

YES >> GO TO 13.

NO >> GO TO 12.

**12. REPLACE HEATED OXYGEN SENSOR 2**

Replace malfunctioning heated oxygen sensor 2. Refer to [EM-223, "Exploded View"](#).

**CAUTION:**

- Discard any heated oxygen sensor which has been dropped from a height of more than 0.5 m (19.7 in) onto a hard surface such as a concrete floor; use a new one.
- Before installing new oxygen sensor, clean exhaust system threads using Oxygen Sensor Thread Cleaner [commercial service tool (J-43897-18 or J-43897-12)] and approved anti-seize lubricant (commercial service tool).

>> INSPECTION END

**13. CHECK INTERMITTENT INCIDENT**

Refer to [GI-44, "Intermittent Incident"](#).

>> INSPECTION END

**Component Inspection (HO2 sensor 2)**

INFOID:000000007758294

**1. INSPECTION START**

Will CONSULT be used?

Will CONSULT be used?

YES >> GO TO 2.

NO >> GO TO 3.

**2. CHECK HEATED OXYGEN SENSOR 2**

**Ⓜ WITH CONSULT**

1. Start engine and warm it up to the normal operating temperature.
2. Start engine and keep the engine speed between 3,500 and 4,000 rpm for at least 1 minute under no load.
3. Let engine idle for 1 minute.
4. Select "FUEL INJECTION" in "ACTIVE TEST" mode, and select "HO2S2 (B1)/(B2)" as the monitor item with CONSULT.
5. Check "HO2S2 (B1)/(B2)" at idle speed when adjusting "FUEL INJECTION" to  $\pm 25\%$ .

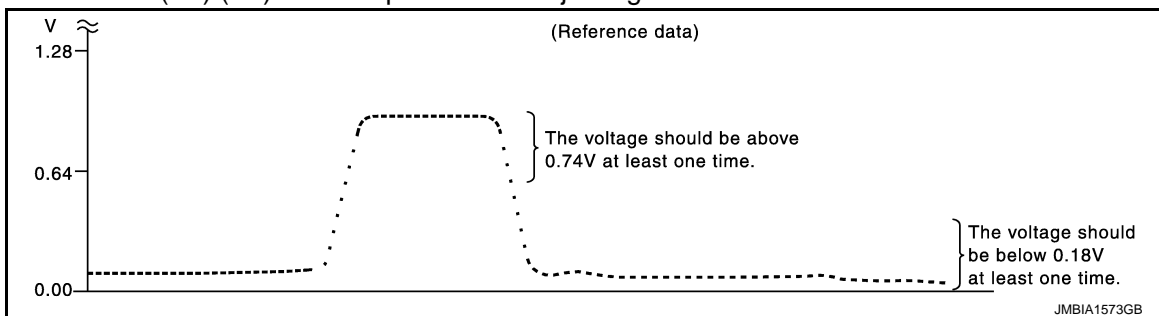

"HO2S2 (B1)/(B2)" should be above 0.74 V at least once when the "FUEL INJECTION" is +25%.  
 "HO2S2 (B1)/(B2)" should be below 0.18 V at least once when the "FUEL INJECTION" is -25%.

Is the inspection result normal?

YES >> INSPECTION END

< DTC/CIRCUIT DIAGNOSIS >

NO >> GO TO 6.

**3.CHECK HEATED OXYGEN SENSOR 2-I**

**⊗ WITHOUT CONSULT**

1. Start engine and warm it up to the normal operating temperature.
2. Turn ignition switch OFF and wait at least 10 seconds.
3. Start engine and keep the engine speed between 3,500 and 4,000 rpm for at least 1 minute under no load.
4. Let engine idle for 1 minute.
5. Check the voltage between ECM harness connector terminals under the following conditions.

| ECM       |                           |          | Condition  | Voltage  |
|-----------|---------------------------|----------|--|--|
| Connector | +                         | -        |  |  |
|           | Terminal                  | Terminal |  |  |
| F111      | 96<br>[HO2S2<br>(bank 1)] | 100      | Reving up to 4,000 rpm under no load at least 10 times | The voltage should be above 0.74 V at least once during this procedure.<br>The voltage should be below 0.18 V at least once during this procedure. |
|           | 87<br>[HO2S2<br>(bank 2)] |          |  |  |

Is the inspection result normal?

YES >> INSPECTION END

NO >> GO TO 4.

**4.CHECK HEATED OXYGEN SENSOR 2-II**

Check the voltage between ECM harness connector terminals under the following conditions.

| ECM       |                           |          | Condition                             | Voltage  |
|-----------|---------------------------|----------|---------------------------------------|--|
| Connector | +                         | -        |                                       |  |
|           | Terminal                  | Terminal |                                       |  |
| F111      | 96<br>[HO2S2<br>(bank 1)] | 100      | Keeping engine at idle for 10 minutes | The voltage should be above 0.74 V at least once during this procedure.<br>The voltage should be below 0.18 V at least once during this procedure. |
|           | 87<br>[HO2S2<br>(bank 2)] |          |                                       |  |

Is the inspection result normal?

YES >> INSPECTION END

NO >> GO TO 5.

**5.CHECK HEATED OXYGEN SENSOR 2-III**

Check the voltage between ECM harness connector terminals under the following conditions.

| ECM       |                           |          | Condition  | Voltage  |
|-----------|---------------------------|----------|--|--|
| Connector | +                         | -        |  |  |
|           | Terminal                  | Terminal |  |  |
| F111      | 96<br>[HO2S2<br>(bank 1)] | 100      | Coasting from 80 km/h (50 MPH) with selector lever in the D position | The voltage should be above 0.74 V at least once during this procedure.<br>The voltage should be below 0.18 V at least once during this procedure. |
|           | 87<br>[HO2S2<br>(bank 2)] |          |  |  |

Is the inspection result normal?

YES >> INSPECTION END

NO >> GO TO 6.

---

6. REPLACE HEATED OXYGEN SENSOR 2

---

Replace malfunctioning heated oxygen sensor 2. Refer to [EM-223, "Exploded View"](#).

**CAUTION:**

- Discard any heated oxygen sensor which has been dropped from a height of more than 0.5 m (19.7 in) onto a hard surface such as a concrete floor; use a new one.
- Before installing new oxygen sensor, clean exhaust system threads using Oxygen Sensor Thread Cleaner [commercial service tool (J-43897-18 or J-43897-12)] and approved anti-seize lubricant (commercial service tool).

>> INSPECTION END



P0139, P0159 HO2S2

DTC Logic

INFOID:000000007758295

DTC DETECTION LOGIC

The heated oxygen sensor 2 has a much longer switching time between rich and lean than the air fuel ratio (A/F) sensor 1. The oxygen storage capacity of the three way catalyst (manifold) causes the longer switching time. To judge the malfunctions of heated oxygen sensor 2, ECM monitors whether the switching response of the sensor's voltage is faster than specified during various driving conditions such as fuel cut.

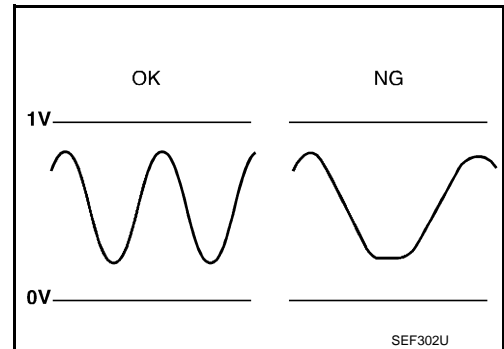

| DTC No. | Trouble diagnosis name<br>(Trouble diagnosis content)                    | DTC detecting condition   | Possible cause  |
|---------|--|---|---|
| P0139   | HO2S2 (B1)<br>[Heated oxygen sensor 2<br>(bank 1) circuit slow response] | It takes more time for the sensor to respond between rich and lean than the specified time. | <ul style="list-style-type: none"> <li>• Harness or connectors (The heated oxygen sensor 2 circuit is open or shorted)</li> <li>• Heated oxygen sensor 2</li> <li>• Fuel pressure</li> <li>• Fuel injector</li> <li>• Intake air leaks</li> </ul> |
| P0159   | HO2S2 (B2)<br>[Heated oxygen sensor 2<br>(bank 2) circuit slow response] |   |   |

DTC CONFIRMATION PROCEDURE

1. PRECONDITIONING

If DTC Confirmation Procedure has been previously conducted, always perform the following procedure before conducting the next test.

1. Turn ignition switch OFF and wait at least 10 seconds.
2. Turn ignition switch ON.
3. Turn ignition switch OFF and wait at least 10 seconds.

Will CONSULT be used?

- YES >> GO TO 2.
- NO >> GO TO 4.

2. PERFORM DTC CONFIRMATION PROCEDURE

Ⓜ WITH CONSULT

TESTING CONDITION:

For better results, perform "DTC WORK SUPPORT" at a temperature of 0 to 30°C (32 to 86°F).

1. Start engine and warm it up to the normal operating temperature.
2. Turn ignition switch OFF and wait at least 10 seconds.
3. Turn ignition switch ON.
4. Turn ignition switch OFF and wait at least 10 seconds.
5. Restart engine and keep the engine speed between 3,500 and 4,000 rpm for at least 1 minute under no load.
6. Let engine idle for 1 minute.
7. Select "DATA MONITOR" mode with CONSULT.
8. Check that "COOLAN TEMP/S" indicates more than 70°C (158°F).  
If not, warm up engine and go to next step when "COOLAN TEMP/S" indication reaches to 70°C (158°F).
9. Open engine hood.
10. Select "HO2S2 (B1) P0139" or "HO2S2 (B2) P0159" of "HO2S2" in "DTC WORK SUPPORT" mode with CONSULT.
11. Start engine and follow the instruction of CONSULT display.

NOTE:

< DTC/CIRCUIT DIAGNOSIS >

It will take at most 10 minutes until "COMPLETED" is displayed.

12. Touch "SELF-DIAG RESULTS".

Which is displayed on CONSULT screen?

- OK >> INSPECTION END
- NG >> Proceed to [EC-1795, "Diagnosis Procedure"](#).
- CAN NOT BE DIAGNOSED>>GO TO 3.

**3.PERFORM DTC CONFIRMATION PROCEDURE AGAIN**

1. Turn ignition switch OFF and leave the vehicle in a cool place (soak the vehicle).
2. Perform DTC confirmation procedure again.

>> GO TO 2.

**4.PERFORM COMPONENT FUNCTION CHECK**

 WITH GST

Perform component function check. Refer to [EC-1794, "Component Function Check"](#).

**NOTE:**

Use component function check to check the overall function of the heated oxygen sensor 2 circuit. During this check, a 1st trip DTC might not be confirmed.

Is the inspection result normal?

- YES >> INSPECTION END
- NO >> Proceed to [EC-1795, "Diagnosis Procedure"](#).

**Component Function Check**

INFOID:000000007758296

**1.PERFORM COMPONENT FUNCTION CHECK-I**

 With GST

1. Start engine and warm it up to the normal operating temperature.
2. Turn ignition switch OFF and wait at least 10 seconds.
3. Turn ignition switch ON.
4. Turn ignition switch OFF and wait at least 10 seconds.
5. Restart engine and keep the engine speed between 3,500 and 4,000 rpm for at least 1 minute under no load.
6. Let engine idle for 1 minute.
7. Check the voltage between ECM harness connector terminals under the following conditions.

| DTC   | ECM       |          |          | Condition   | Voltage  |
|-------|-----------|----------|----------|---|--|
|       | Connector | +        | -        |   |  |
|       |           | Terminal | Terminal |   |  |
| P0139 | F111      | 96       | 100      | Revving up to 4,000 rpm under no load at least 10 times | A change of voltage should be more than 0.24 V for 1 second during this procedure. |
| P0159 |           | 87       |          |   |  |

Is the inspection result normal?

- YES >> INSPECTION END
- NO >> GO TO 2.

**2.PERFORM COMPONENT FUNCTION CHECK-II**

Check the voltage between ECM harness connector terminals under the following conditions.

| DTC   | ECM       |          |          | Condition                             | Voltage  |
|-------|-----------|----------|----------|---------------------------------------|--|
|       | Connector | +        | -        |                                       |  |
|       |           | Terminal | Terminal |                                       |  |
| P0139 | F111      | 96       | 100      | Keeping engine at idle for 10 minutes | A change of voltage should be more than 0.24 V for 1 second during this procedure. |
| P0159 |           | 87       |          |                                       |  |

Is the inspection result normal?

< DTC/CIRCUIT DIAGNOSIS >

YES >> INSPECTION END  
 NO >> GO TO 3.

**3.PERFORM COMPONENT FUNCTION CHECK-III**

Check the voltage between ECM harness connector terminals under the following conditions.

| DTC   | ECM       |          |          | Condition  | Voltage  |
|-------|-----------|----------|----------|--|--|
|       | Connector | +        | -        |  |  |
|       |           | Terminal | Terminal |  |  |
| P0139 | F111      | 96       | 100      | Coasting from 80 km/h (50 MPH) with selector lever in the D position | A change of voltage should be more than 0.24 V for 1 second during this procedure. |
| P0159 |           | 87       |          |  |  |

Is the inspection result normal?

YES >> INSPECTION END  
 NO >> Proceed to [EC-1795, "Diagnosis Procedure"](#).

**Diagnosis Procedure**

INFOID:000000007758297

**1.CLEAR THE MIXTURE RATIO SELF-LEARNING VALUE**

1. Clear the mixture ratio self-learning value. Refer to [EC-1691, "Work Procedure"](#).
2. Run engine for at least 10 minutes at idle speed.

Is the 1st trip DTC P0171, P0172, P0174 or P0175 detected? Is it difficult to start engine?

YES >> Perform trouble diagnosis for DTC P0171, P0174 or P0172, P0175. Refer to [EC-1799, "DTC Logic"](#) or [EC-1803, "DTC Logic"](#).  
 NO >> GO TO 2.

**2.CHECK HEATED OXYGEN SENSOR 2 GROUND CIRCUIT FOR OPEN AND SHORT**

1. Turn ignition switch OFF.
2. Disconnect heated oxygen sensor 2 (HO2S2) harness connector.
3. Disconnect ECM harness connector.
4. Check the continuity between HO2S2 harness connector and ECM harness connector.

| DTC   | HO2S2 |           |          | ECM       |          | Continuity |
|-------|-------|-----------|----------|-----------|----------|------------|
|       | Bank  | Connector | Terminal | Connector | Terminal |            |
| P0139 | 1     | F87       | 1        | F111      | 100      | Existed    |
| P0159 | 2     | F88       | 1        |           |          |            |

5. Also check harness for short to ground and short to power.

Is the inspection result normal?

YES >> GO TO 3.  
 NO >> Repair open circuit, short to ground or short to power in harness or connectors.

**3.CHECK HO2S2 INPUT SIGNAL CIRCUIT FOR OPEN AND SHORT**

1. Check the continuity between HO2S2 harness connector and ECM harness connector.

| DTC   | HO2S2 |           |          | ECM       |          | Continuity |
|-------|-------|-----------|----------|-----------|----------|------------|
|       | Bank  | Connector | Terminal | Connector | Terminal |            |
| P0139 | 1     | F87       | 4        | F111      | 96       | Existed    |
| P0159 | 2     | F88       | 4        |           | 87       |            |

2. Check the continuity between HO2S2 harness connector and ground, or ECM harness connector and ground.

< DTC/CIRCUIT DIAGNOSIS >

| DTC   | HO2S2 |           |          | ECM       |          | Ground | Continuity  |
|-------|-------|-----------|----------|-----------|----------|--------|-------------|
|       | Bank  | Connector | Terminal | Connector | Terminal |        |             |
| P0139 | 1     | F87       | 4        | F111      | 96       | Ground | Not existed |
| P0159 | 2     | F88       | 4        |           | 87       |        |             |

3. Also check harness for short to power.

Is the inspection result normal?

YES >> GO TO 4.

NO >> Repair open circuit, short to ground or short to power in harness or connectors.

**4.CHECK HEATED OXYGEN SENSOR 2**

Refer to [EC-1796, "Component Inspection \(HO2 sensor 2\)"](#).

Is the inspection result normal?

YES >> GO TO 6.

NO >> GO TO 5.

**5.REPLACE HEATED OXYGEN SENSOR 2**

Replace malfunctioning heated oxygen sensor 2. Refer to [EM-223, "Exploded View"](#).

**CAUTION:**

- Discard any heated oxygen sensor which has been dropped from a height of more than 0.5 m (19.7 in) onto a hard surface such as a concrete floor; use a new one.
- Before installing new oxygen sensor, clean exhaust system threads using Oxygen Sensor Thread Cleaner [commercial service tool (J-43897-18 or J-43897-12)] and approved anti-seize lubricant (commercial service tool).

>> INSPECTION END

**6.CHECK INTERMITTENT INCIDENT**

Refer to [GI-44, "Intermittent Incident"](#).

>> INSPECTION END

Component Inspection (HO2 sensor 2)

INFOID:000000007758298

**1.INSPECTION START**

Will CONSULT be used?

Will CONSULT be used?

YES >> GO TO 2.

NO >> GO TO 3.

**2.CHECK HEATED OXYGEN SENSOR 2**

**Ⓜ WITH CONSULT**

1. Start engine and warm it up to the normal operating temperature.
2. Start engine and keep the engine speed between 3,500 and 4,000 rpm for at least 1 minute under no load.
3. Let engine idle for 1 minute.
4. Select "FUEL INJECTION" in "ACTIVE TEST" mode, and select "HO2S2 (B1)/(B2)" as the monitor item with CONSULT.

< DTC/CIRCUIT DIAGNOSIS >

5. Check "HO2S2 (B1)/(B2)" at idle speed when adjusting "FUEL INJECTION" to  $\pm 25\%$ .

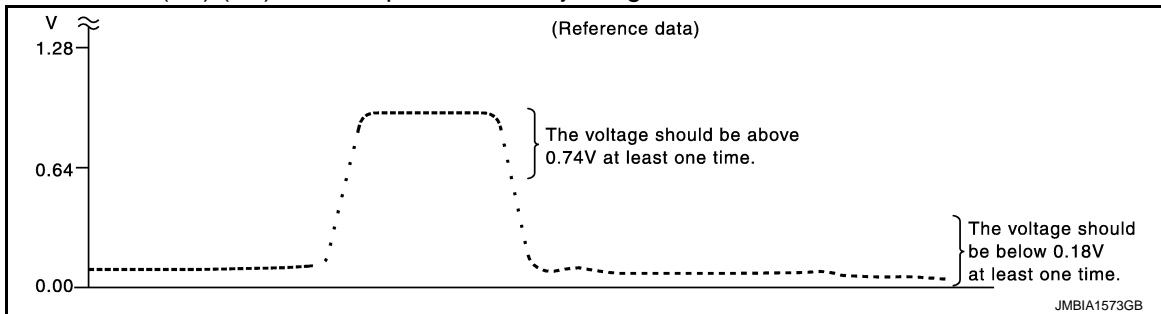

"HO2S2 (B1)/(B2)" should be above 0.74 V at least once when the "FUEL INJECTION" is +25%.  
 "HO2S2 (B1)/(B2)" should be below 0.18 V at least once when the "FUEL INJECTION" is -25%.

Is the inspection result normal?

- YES >> INSPECTION END
- NO >> GO TO 6.

**3.CHECK HEATED OXYGEN SENSOR 2-I**

WITHOUT CONSULT

1. Start engine and warm it up to the normal operating temperature.
2. Turn ignition switch OFF and wait at least 10 seconds.
3. Start engine and keep the engine speed between 3,500 and 4,000 rpm for at least 1 minute under no load.
4. Let engine idle for 1 minute.
5. Check the voltage between ECM harness connector terminals under the following conditions.

| Connector | ECM                       |          | Condition  | Voltage  |
|-----------|---------------------------|----------|--|--|
|           | +                         | -        |  |  |
|           | Terminal                  | Terminal |  |  |
| F111      | 96<br>[HO2S2<br>(bank 1)] | 100      | Revvng up to 4,000 rpm under no load at least 10 times | The voltage should be above 0.74 V at least once during this procedure.<br>The voltage should be below 0.18 V at least once during this procedure. |
|           | 87<br>[HO2S2<br>(bank 2)] |          |  |  |

Is the inspection result normal?

- YES >> INSPECTION END
- NO >> GO TO 4.

**4.CHECK HEATED OXYGEN SENSOR 2-II**

Check the voltage between ECM harness connector terminals under the following conditions.

| Connector | ECM                       |          | Condition                             | Voltage  |
|-----------|---------------------------|----------|---------------------------------------|--|
|           | +                         | -        |                                       |  |
|           | Terminal                  | Terminal |                                       |  |
| F111      | 96<br>[HO2S2<br>(bank 1)] | 100      | Keeping engine at idle for 10 minutes | The voltage should be above 0.74 V at least once during this procedure.<br>The voltage should be below 0.18 V at least once during this procedure. |
|           | 87<br>[HO2S2<br>(bank 2)] |          |                                       |  |

Is the inspection result normal?

- YES >> INSPECTION END
- NO >> GO TO 5.

**5.CHECK HEATED OXYGEN SENSOR 2-III**

Check the voltage between ECM harness connector terminals under the following conditions.

# P0139, P0159 HO2S2

< DTC/CIRCUIT DIAGNOSIS >

[VK56VD FOR MEXICO]

| ECM       |                           |          | Condition  | Voltage  |
|-----------|---------------------------|----------|--|--|
| Connector | +                         | -        |  |  |
|           | Terminal                  | Terminal |  |  |
| F111      | 96<br>[HO2S2<br>(bank 1)] | 100      | Coasting from 80 km/h (50 MPH) with selector lever in the D position | The voltage should be above 0.74 V at least once during this procedure.<br>The voltage should be below 0.18 V at least once during this procedure. |
|           | 87<br>[HO2S2<br>(bank 2)] |          |  |  |

Is the inspection result normal?

YES >> INSPECTION END

NO >> GO TO 6.

## 6. REPLACE HEATED OXYGEN SENSOR 2

Replace malfunctioning heated oxygen sensor 2. Refer to [EM-223. "Exploded View"](#).

### CAUTION:

- Discard any heated oxygen sensor which has been dropped from a height of more than 0.5 m (19.7 in) onto a hard surface such as a concrete floor; use a new one.
- Before installing new oxygen sensor, clean exhaust system threads using Oxygen Sensor Thread Cleaner [commercial service tool (J-43897-18 or J-43897-12)] and approved anti-seize lubricant (commercial service tool).

>> INSPECTION END

# P0171, P0174 FUEL INJECTION SYSTEM FUNCTION

< DTC/CIRCUIT DIAGNOSIS >

[VK56VD FOR MEXICO]

## P0171, P0174 FUEL INJECTION SYSTEM FUNCTION

### DTC Logic

INFOID:000000007758299

#### DTC DETECTION LOGIC

With the Air/Fuel Mixture Ratio Self-Learning Control, the actual mixture ratio can be brought closely to the theoretical mixture ratio based on the mixture ratio feedback signal from A/F sensor 1. The ECM calculates the necessary compensation to correct the offset between the actual and the theoretical ratios.

In case the amount of the compensation value is extremely large (the actual mixture ratio is too lean), the ECM judges the condition as the fuel injection system malfunction and illuminates the MIL (2 trip detection logic).

| Sensor       | Input signal to ECM  | ECM function           | Actuator      |
|--------------|--|------------------------|---------------|
| A/F sensor 1 | Density of oxygen in exhaust gas (Mixture ratio feedback signal) | Fuel injection control | Fuel injector |

| DTC No. | Trouble diagnosis name (Trouble diagnosis content)         | DTC detecting condition   | Possible cause   |
|---------|--|---|--|
| P0171   | FUEL SYS-LEAN-B1 [Fuel injection system too lean (bank 1)] | • Fuel injection system does not operate properly.<br>• The amount of mixture ratio compensation is too large. (The mixture ratio is too lean.) | • Intake air leakage<br>• A/F sensor 1<br>• Fuel injector<br>• Exhaust gas leakage<br>• Incorrect fuel pressure<br>• Lack of fuel<br>• Mass air flow sensor<br>• Incorrect PCV hose connection |
| P0174   | FUEL SYS-LEAN-B2 [Fuel injection system too lean (bank 2)] |   |  |

#### DTC CONFIRMATION PROCEDURE

##### 1. PRECONDITIONING

If DTC Confirmation Procedure has been previously conducted, always perform the following procedure before conducting the next test.

1. Turn ignition switch OFF and wait at least 10 seconds.
2. Turn ignition switch ON.
3. Turn ignition switch OFF and wait at least 10 seconds.

>> GO TO 2.

##### 2. PERFORM DTC CONFIRMATION PROCEDURE-I

1. Clear the mixture ratio self-learning value. Refer to [EC-1691, "Work Procedure"](#).
2. Start engine.

Is it difficult to start engine?

YES >> GO TO 3.

NO >> GO TO 4.

##### 3. RESTART ENGINE

If it is difficult to start engine, the fuel injection system has a malfunction, too.

Crank engine while depressing accelerator pedal.

#### NOTE:

When depressing accelerator pedal three fourths (3/4) or more, the control system does not start the engine. Do not depress accelerator pedal too much.

Does engine start?

YES >> Proceed to [EC-1800, "Diagnosis Procedure"](#).

NO >> Check exhaust and intake air leakage visually.

##### 4. PERFORM DTC CONFIRMATION PROCEDURE-II

1. Keep engine idle for at least 5 minutes.
2. Check 1st trip DTC.

# P0171, P0174 FUEL INJECTION SYSTEM FUNCTION

< DTC/CIRCUIT DIAGNOSIS >

[VK56VD FOR MEXICO]

Is 1st trip DTC detected?

- YES >> Proceed to [EC-1800, "Diagnosis Procedure"](#).
- NO >> GO TO 5.

## 5.PERFORM DTC CONFIRMATION PROCEDURE-III

1. Turn ignition switch OFF and wait at least 10 seconds.
2. Turn ignition switch ON.
3. Turn ignition switch OFF and wait at least 10 seconds.
4. Start engine.
5. Maintain the following conditions for at least 10 consecutive minutes.  
**Hold the accelerator pedal as steady as possible.**

|               |                             |
|---------------|-----------------------------|
| Vehicle speed | 50 - 120 km/h (31 - 75 MPH) |
|---------------|-----------------------------|

### CAUTION:

**Always drive vehicle at a safe speed.**

6. Check 1st trip DTC.

Is 1st trip DTC detected?

- YES >> Proceed to [EC-1800, "Diagnosis Procedure"](#).
- NO >> INSPECTION END

## Diagnosis Procedure

INFOID:000000007758300

### 1.CHECK EXHAUST GAS LEAKAGE

1. Start engine and run it at idle.
2. Listen for an exhaust gas leakage before three way catalyst (manifold).

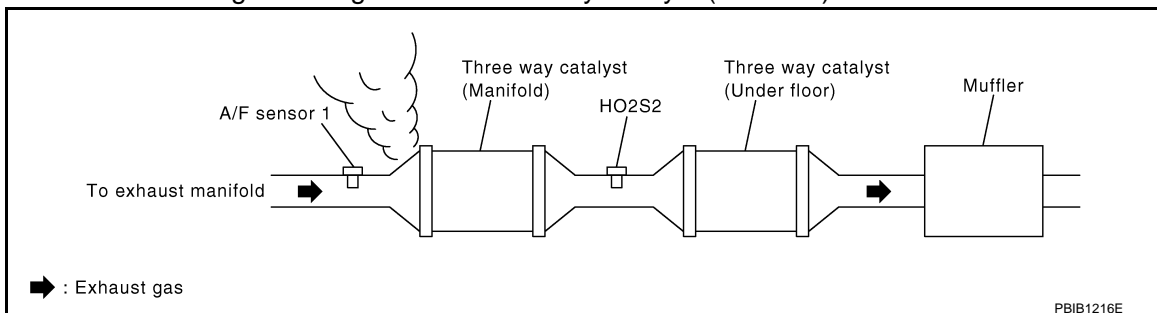

Is exhaust gas leakage detected?

- YES >> Repair or replace malfunctioning part.
- NO >> GO TO 2.

### 2.CHECK FOR INTAKE AIR LEAKAGE

1. Listen for an intake air leakage after the mass air flow sensor.
2. Check PCV hose connection.

Is intake air leakage detected?

- YES >> Repair or replace malfunctioning part.
- NO >> GO TO 3.

### 3.CHECK A/F SENSOR 1 CIRCUIT

1. Turn ignition switch OFF.
2. Disconnect corresponding A/F sensor 1 harness connector.
3. Disconnect ECM harness connector.
4. Check the continuity between A/F sensor 1 harness connector and ECM harness connector.



# P0171, P0174 FUEL INJECTION SYSTEM FUNCTION

< DTC/CIRCUIT DIAGNOSIS >

[VK56VD FOR MEXICO]

| DTC   | A/F sensor 1 |           |          | ECM       |          | Continuity |
|-------|--------------|-----------|----------|-----------|----------|------------|
|       | Bank         | Connector | Terminal | Connector | Terminal |            |
| P0171 | 1            | F23       | 3        | F111      | 88       | Existed    |
|       |              |           | 4        |           | 90       |            |
|       |              |           | 6        |           | 94       |            |
| P0174 | 2            | F24       | 3        |           | 78       |            |
|       |              |           | 4        |           | 80       |            |
|       |              |           | 6        |           | 74       |            |

5. Check the continuity between A/F sensor 1 harness connector and ground, or ECM harness connector and ground.

| DTC   | A/F sensor 1 |           |          | ECM       |          | Continuity | Continuity  |
|-------|--------------|-----------|----------|-----------|----------|------------|-------------|
|       | Bank         | Connector | Terminal | Connector | Terminal |            |             |
| P0171 | 1            | F23       | 3        | F111      | 88       | Existed    | Not existed |
|       |              |           | 4        |           | 90       |            |             |
|       |              |           | 6        |           | 94       |            |             |
| P0174 | 2            | F24       | 3        |           | 78       |            |             |
|       |              |           | 4        |           | 80       |            |             |
|       |              |           | 6        |           | 74       |            |             |

6. Also check harness for short to power.

Is the inspection result normal?

YES >> GO TO 4.

NO >> Repair open circuit, short to ground or short to power in harness or connectors.

## 4. CHECK FUEL PRESSURE

Check fuel pressure. Refer to [EC-1692, "Work Procedure"](#).

Is the inspection result normal?

YES >> GO TO 6.

NO >> GO TO 5.

## 5. DETECT MALFUNCTIONING PART

Check fuel hoses and fuel tubes for clogging.

Is the inspection result normal?

YES >> Replace "fuel filter and fuel pump assembly". Refer to [FL-6, "Removal and Installation"](#).

NO >> Repair or replace malfunctioning part.

## 6. CHECK MASS AIR FLOW SENSOR

 WITH CONSULT

1. Install all removed parts.
2. Check "MASS AIR FLOW" in "DATA MONITOR" mode with CONSULT.  
For specification, refer to [EC-2016, "Mass Air Flow Sensor"](#).

 WITH GST

1. Install all removed parts.
2. Check mass air flow sensor signal in Service \$01 with GST.  
For specification, refer to [EC-2016, "Mass Air Flow Sensor"](#).

Is the measurement value within the specification?

YES >> GO TO 7.

NO >> Check connectors for rusted terminals or loose connections in the mass air flow sensor circuit or grounds. Refer to [EC-1750, "Diagnosis Procedure"](#).

## 7. CHECK FUNCTION OF FUEL INJECTOR

# P0171, P0174 FUEL INJECTION SYSTEM FUNCTION

< DTC/CIRCUIT DIAGNOSIS >

[VK56VD FOR MEXICO]

## ④ WITH CONSULT

1. Start engine.
2. Perform "POWER BALANCE" in "ACTIVE TEST" mode with CONSULT.
3. Check that each circuit produces a momentary engine speed drop.

## ⊗ WITHOUT CONSULT

1. Start engine and let it idle.
2. Listen to each fuel injector operating sound.

**Clicking sound should be heard.**

Is the inspection result normal?

YES >> GO TO 8.

NO >> Perform trouble diagnosis for fuel injector, refer to [EC-1976](#), "Diagnosis Procedure".

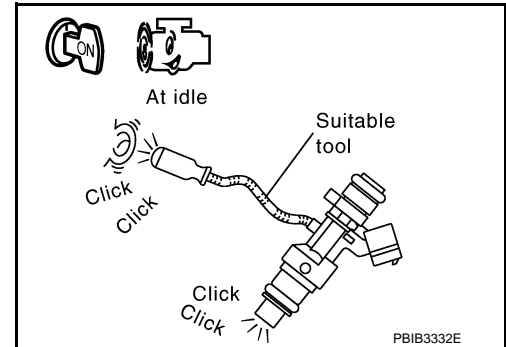

## 8. CHECK INTERMITTENT INCIDENT

Refer to [GI-44](#), "Intermittent Incident".

Is the inspection result normal?

YES >> Replace fuel injector. Refer to [EM-197](#), "Removal and Installation".

NO >> Repair or replace malfunctioning part.

# P0172, P0175 FUEL INJECTION SYSTEM FUNCTION

< DTC/CIRCUIT DIAGNOSIS >

[VK56VD FOR MEXICO]

## P0172, P0175 FUEL INJECTION SYSTEM FUNCTION

### DTC Logic

INFOID:000000007758301

#### DTC DETECTION LOGIC

With the Air/Fuel Mixture Ratio Self-Learning Control, the actual mixture ratio can be brought closely to the theoretical mixture ratio based on the mixture ratio feedback signal from A/F sensor 1. The ECM calculates the necessary compensation to correct the offset between the actual and the theoretical ratios.

In case the amount of the compensation value is extremely large (the actual mixture ratio is too rich), the ECM judges the condition as the fuel injection system malfunction and illuminates the MIL (2 trip detection logic).

| Sensor       | Input signal to ECM  | ECM function           | Actuator      |
|--------------|--|------------------------|---------------|
| A/F sensor 1 | Density of oxygen in exhaust gas (Mixture ratio feedback signal) | Fuel injection control | Fuel injector |

| DTC No. | Trouble diagnosis name (Trouble diagnosis content)         | DTC detecting condition  | Possible cause  |
|---------|--|--|---|
| P0172   | FUEL SYS-RICH-B1 [Fuel injection system too rich (bank 1)] | <ul style="list-style-type: none"><li>Fuel injection system does not operate properly.</li><li>The amount of mixture ratio compensation is too large. (The mixture ratio is too rich.)</li></ul> | <ul style="list-style-type: none"><li>A/F sensor 1</li><li>Fuel injector</li><li>Exhaust gas leakage</li><li>Incorrect fuel pressure</li><li>Mass air flow sensor</li></ul> |
| P0175   | FUEL SYS-RICH-B2 [Fuel injection system too rich (bank 2)] |  |   |

#### DTC CONFIRMATION PROCEDURE

##### 1. PRECONDITIONING

If DTC Confirmation Procedure has been previously conducted, always perform the following procedure before conducting the next test.

- Turn ignition switch OFF and wait at least 10 seconds.
- Turn ignition switch ON.
- Turn ignition switch OFF and wait at least 10 seconds.

>> GO TO 2.

##### 2. PERFORM DTC CONFIRMATION PROCEDURE-I

- Clear the mixture ratio self-learning value. Refer to [EC-1691, "Work Procedure"](#).
- Start engine.

Is it difficult to start engine?

YES >> GO TO 3.

NO >> GO TO 4.

##### 3. RESTART ENGINE

If it is difficult to start engine, the fuel injection system has a malfunction, too.

Crank engine while depressing accelerator pedal.

#### NOTE:

When depressing accelerator pedal three fourths (3/4) or more, the control system does not start the engine. Do not depress accelerator pedal too much.

Does engine start?

YES >> Proceed to [EC-1804, "Diagnosis Procedure"](#).

NO >> Remove spark plugs and check for fouling, etc.

##### 4. PERFORM DTC CONFIRMATION PROCEDURE-II

- Keep engine idle for at least 5 minutes.
- Check 1st trip DTC.

Is 1st trip DTC detected?

YES >> Proceed to [EC-1804, "Diagnosis Procedure"](#).

# P0172, P0175 FUEL INJECTION SYSTEM FUNCTION

< DTC/CIRCUIT DIAGNOSIS >

[VK56VD FOR MEXICO]

NO >> GO TO 5.

## 5. PERFORM DTC CONFIRMATION PROCEDURE-III

1. Turn ignition switch OFF and wait at least 10 seconds.
2. Turn ignition switch ON.
3. Turn ignition switch OFF and wait at least 10 seconds.
4. Start engine.
5. Maintain the following conditions for at least 10 consecutive minutes.  
**Hold the accelerator pedal as steady as possible.**

|               |                             |
|---------------|-----------------------------|
| Vehicle speed | 50 - 120 km/h (31 - 75 MPH) |
|---------------|-----------------------------|

### CAUTION:

**Always drive vehicle at a safe speed.**

6. Check 1st trip DTC.

Is 1st trip DTC detected?

YES >> Proceed to [EC-1804, "Diagnosis Procedure"](#).

NO >> INSPECTION END

## Diagnosis Procedure

INFOID:000000007758302

### 1. CHECK EXHAUST GAS LEAKAGE

1. Start engine and run it at idle.
2. Listen for an exhaust gas leakage before three way catalyst (manifold).

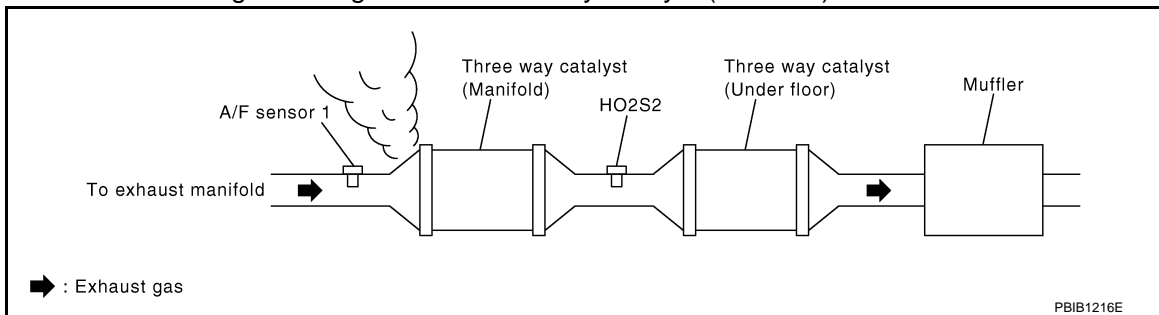

Is exhaust gas leakage detected?

YES >> Repair or replace malfunctioning part.

NO >> GO TO 2.

### 2. CHECK FOR INTAKE AIR LEAKAGE

Listen for an intake air leakage after the mass air flow sensor.

Is intake air leakage detected?

YES >> Repair or replace malfunctioning part.

NO >> GO TO 3.

### 3. CHECK A/F SENSOR 1 CIRCUIT

1. Turn ignition switch OFF.
2. Disconnect corresponding A/F sensor 1 harness connector.
3. Disconnect ECM harness connector.
4. Check the continuity between A/F sensor 1 harness connector and ECM harness connector.

# P0172, P0175 FUEL INJECTION SYSTEM FUNCTION

< DTC/CIRCUIT DIAGNOSIS >

[VK56VD FOR MEXICO]

| DTC   | A/F sensor 1 |           |          | ECM       |          | Continuity |
|-------|--------------|-----------|----------|-----------|----------|------------|
|       | Bank         | Connector | Terminal | Connector | Terminal |            |
| P0171 | 1            | F23       | 3        | F111      | 88       | Existed    |
|       |              |           | 4        |           | 90       |            |
|       |              |           | 6        |           | 94       |            |
| P0174 | 2            | F24       | 3        |           | 78       |            |
|       |              |           | 4        |           | 80       |            |
|       |              |           | 6        |           | 74       |            |

5. Check the continuity between A/F sensor 1 harness connector and ground, or ECM harness connector and ground.

| DTC   | A/F sensor 1 |           |          | ECM       |          | Continuity | Continuity  |
|-------|--------------|-----------|----------|-----------|----------|------------|-------------|
|       | Bank         | Connector | Terminal | Connector | Terminal |            |             |
| P0171 | 1            | F23       | 3        | F111      | 88       | Existed    | Not existed |
|       |              |           | 4        |           | 90       |            |             |
|       |              |           | 6        |           | 94       |            |             |
| P0174 | 2            | F24       | 3        |           | 78       |            |             |
|       |              |           | 4        |           | 80       |            |             |
|       |              |           | 6        |           | 74       |            |             |

6. Also check harness for short to power.

Is the inspection result normal?

YES >> GO TO 4.

NO >> Repair open circuit, short to ground or short to power in harness or connectors.

## 4. CHECK FUEL PRESSURE

Check fuel pressure. Refer to [EC-1692, "Work Procedure"](#).

Is the inspection result normal?

YES >> GO TO 5.

NO >> Replace fuel filter and fuel pump assembly". Refer to [FL-6, "Removal and Installation"](#).

## 5. CHECK MASS AIR FLOW SENSOR

 WITH CONSULT

1. Install all removed parts.
2. Check "MASS AIR FLOW" in "DATA MONITOR" mode with CONSULT.  
For specification, refer to [EC-2016, "Mass Air Flow Sensor"](#).

 WITH GST

1. Install all removed parts.
2. Check mass air flow sensor signal in "Service \$01" with GST.  
For specification, refer to [EC-2016, "Mass Air Flow Sensor"](#).

Is the measurement value within the specification?

YES >> GO TO 6.

NO >> Check connectors for rusted terminals or loose connections in the mass air flow sensor circuit or grounds. Refer to [EC-1750, "Diagnosis Procedure"](#).

## 6. CHECK FUNCTION OF FUEL INJECTOR

 WITH CONSULT

1. Start engine.
2. Perform "POWER BALANCE" in "ACTIVE TEST" mode with CONSULT.
3. Check that each circuit produces a momentary engine speed drop.

 WITHOUT CONSULT

1. Start engine and let it idle.

## P0172, P0175 FUEL INJECTION SYSTEM FUNCTION

< DTC/CIRCUIT DIAGNOSIS >

[VK56VD FOR MEXICO]

2. Listen to each fuel injector operating sound.

**Clicking sound should be heard.**

Is the inspection result normal?

YES >> GO TO 7.

NO >> Perform trouble diagnosis for fuel injector, refer to [EC-1976. "Diagnosis Procedure"](#).

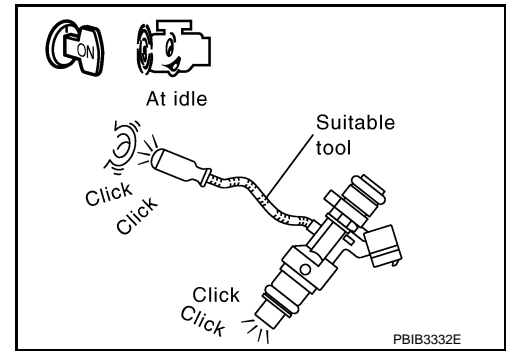

### 7. CHECK INTERMITTENT INCIDENT

Refer to [GI-44. "Intermittent Incident"](#).

Is the inspection result normal?

YES >> Replace fuel injector. Refer to [EM-197. "Removal and Installation"](#).

NO >> Repair or replace malfunctioning part.

# P0190 FRP SENSOR

< DTC/CIRCUIT DIAGNOSIS >

[VK56VD FOR MEXICO]

## P0190 FRP SENSOR

### DTC Logic

INFOID:000000007758309

### DTC DETECTION LOGIC

| DTC No. | Trouble diagnosis name                                     | DTC detecting condition  | Possible cause  |
|---------|--|--|---|
| P0190   | Fuel rail pressure sensor circuit low input and high input | Signal voltage from the fuel rail pressure sensor remains at more than 4.84 V / less than 0.2 V for 5 seconds or more. | <ul style="list-style-type: none"> <li>• Harness or connectors (Fuel rail pressure sensor circuit is open or shorted.) (Power steering pressure sensor circuit is open or shorted.) (Low fuel pressure sensor circuit is open or shorted.) (Engine oil pressure sensor circuit is open or shorted.)</li> <li>• Fuel rail pressure sensor</li> <li>• Power steering pressure sensor</li> <li>• Low fuel pressure sensor</li> <li>• Engine oil pressure sensor</li> </ul> |

### DTC CONFIRMATION PROCEDURE

#### 1. PRECONDITIONING

If DTC Confirmation Procedure has been previously conducted, always perform the following procedure before conducting the next test.

1. Turn ignition switch OFF and wait at least 10 seconds.
2. Turn ignition switch ON.
3. Turn ignition switch OFF and wait at least 10 seconds.

#### TESTING CONDITION:

Before performing the following procedure, confirm that battery voltage is 11 V or more at idle.

>> GO TO 2.

#### 2. PERFORM DTC CONFIRMATION PROCEDURE

1. Start the engine ON and wait at least 60 seconds.
2. Check DTC or 1st trip DTC.

Is DTC or 1st trip DTC detected?

- YES >> Proceed to [EC-1807, "Diagnosis Procedure"](#).  
 NO >> INSPECTION END

### Diagnosis Procedure

INFOID:000000007758310

#### 1. CHECK FRP SENSOR POWER SUPPLY-I

1. Turn ignition switch OFF.
2. Disconnect FRP sensor connector.
3. Turn ignition switch ON.
4. Check the voltage between FRP sensor harness connector terminals.

| Connector | FRP sensor |   | Voltage (Approx.) |
|-----------|------------|---|-------------------|
|           | +          | - |                   |
| F6        | 1          | 3 | 5 V               |

Inspection result normal?

- YES >> GO TO 6.  
 NO >> GO TO 2.

#### 2. CHECK FRP SENSOR POWER SUPPLY-II

# P0190 FRP SENSOR

[VK56VD FOR MEXICO]

## < DTC/CIRCUIT DIAGNOSIS >

Check the voltage between FRP sensor harness connector and the ground.

| +          |          | -      | Voltage<br>(Approx.) |
|------------|----------|--------|----------------------|
| FRP sensor |          |        |                      |
| Connector  | Terminal |        |                      |
| F6         | 1        | Ground | 5 V                  |

Is inspection result normal?

- YES >> GO TO 4.
- NO >> GO TO 3.

### 3.CHECK SENSOR POWER SUPPLY CIRCUIT

1. Turn ignition switch OFF.
2. Disconnect ECM harness connector.
3. Check harness connector for short to power and short to ground, between the following terminals.

| ECM       |          | Sensor                         |           |          |
|-----------|----------|--------------------------------|-----------|----------|
| Connector | Terminal | Name                           | Connector | Terminal |
| F110      | 27       | Power steering pressure sensor | F35       | 3        |
|           |          | Low fuel pressure sensor       | F39       | 3        |
|           | 28       | FRP sensor                     | F6        | 1        |
|           |          | Engine oil pressure sensor     | F32       | 3        |

Is inspection result normal?

- YES >> Perform the trouble diagnosis for power supply circuit. Refer to [EC-1707. "Diagnosis Procedure"](#).
- NO >> Repair or replace error-detected parts.

### 4.CHECK FRP SENSOR GROUND CIRCUIT

1. Turn ignition switch OFF.
2. Disconnect ECM harness connector.
3. Check the continuity between FRP sensor harness connector and ECM harness connector.

| +          |          | -         |          | Continuity |
|------------|----------|-----------|----------|------------|
| FRP sensor |          | ECM       |          |            |
| Connector  | Terminal | Connector | Terminal |            |
| F6         | 3        | F110      | 40       | Existed    |

Is inspection result normal?

- YES >> GO TO 5.
- NO >> Repair or replace error-detected parts.

### 5.CHECK ECM GROUND CIRCUIT

Check the continuity between ECM harness connector and the ground.

| ECM       |          | Ground | Continuity |
|-----------|----------|--------|------------|
| Connector | Terminal |        |            |
| F110      | 10       | Ground | Existed    |
| M160      | 114      |        |            |
|           | 115      |        |            |
|           | 174      |        |            |
|           | 175      |        |            |

Is inspection result normal?

- YES >> Check intermittent incident. Refer to [GI-44. "Intermittent Incident"](#).
- NO >> Repair or replace error-detected parts.



# P0190 FRP SENSOR

< DTC/CIRCUIT DIAGNOSIS >

[VK56VD FOR MEXICO]

## 6. CHECK FRP SENSOR SIGNAL CIRCUIT

1. Turn ignition switch OFF.
2. Disconnect ECM harness connector.
3. Check the continuity between FRP sensor harness connector and ECM harness connector.

| +          |          | -         |          | Continuity |
|------------|----------|-----------|----------|------------|
| FRP sensor |          | ECM       |          |            |
| Connector  | Terminal | Connector | Terminal |            |
| F6         | 2        | F110      | 31       | Existed    |

4. Also check harness for short to ground and to power.

Is inspection result normal?

- YES >> GO TO 7.  
 NO >> Repair or replace error-detected parts.

## 7. CHECK FRP SENSOR

Refer to [EC-1809, "Component Inspection \(Fuel Rail Pressure Sensor\)"](#).

Is inspection result normal?

- YES >> Check intermittent incident. Refer to [GI-44, "Intermittent Incident"](#).  
 NO >> Repair or replace error-detected parts.

## Component Inspection (Fuel Rail Pressure Sensor)

INFOID:000000007758311

### 1. CHECK FRP SENSOR

#### WITH CONSULT

1. Turn ignition switch OFF.
2. Reconnect harness connector disconnected.
3. Start the engine.
4. Select "DATA MONITOR" mode with CONSULT.
5. Check that the "FUEL PRES SEN V" indication.

| Monitor Item    | Condition   | Values/Status  |
|-----------------|---|----------------|
| FUEL PRES SEN V | Engine speed: Idle  | 820 – 1,220 mV |
|                 | Engine speed: Revving engine from idle to 4,000 rpm quickly | 820 – 3,060 mV |

#### WITHOUT CONSULT

1. Turn ignition switch OFF.
2. Reconnect harness connector disconnected.
3. Start the engine.
4. Check FRP sensor signal voltage.

| +         |          | -         |          | Condition   | Value (Approx.) |
|-----------|----------|-----------|----------|---|-----------------|
| ECM       |          |           |          |   |                 |
| Connector | Terminal | Connector | Terminal |   |                 |
| F110      | 31       | F110      | 40       | [Engine is running]<br>• Warm-up condition<br>• Idle speed                                    | 0.82 – 1.22 V   |
|           |          |           |          | [Engine is running]<br>• Warm-up condition<br>• Revving engine from idle to 4,000 rpm quickly | 0.82 – 3.06 V   |

Is the inspection result normal?

- YES >> INSPECTION END.  
 NO >> Replace FRP sensor. Refer to [EM-197, "Exploded View"](#).

# P0197, P0198 EOT SENSOR

< DTC/CIRCUIT DIAGNOSIS >

[VK56VD FOR MEXICO]

## P0197, P0198 EOT SENSOR

### DTC Logic

INFOID:000000007758318

### DTC DETECTION LOGIC

| DTC No. | Trouble diagnosis name<br>(Trouble diagnosis content)              | DTC Detecting Condition                                     | Possible Cause   |
|---------|--|---|--|
| P0197   | EOT SEN/CIRC<br>(Engine oil temperature sensor circuit low input)  | An excessively low voltage from the sensor is sent to ECM.  | <ul style="list-style-type: none"><li>• Harness or connectors<br/>(The EOT sensor circuit is open or shorted.)</li><li>• Engine oil temperature sensor</li></ul> |
| P0198   | EOT SEN/CIRC<br>(Engine oil temperature sensor circuit high input) | An excessively high voltage from the sensor is sent to ECM. |  |

### DTC CONFIRMATION PROCEDURE

#### 1. PRECONDITIONING

If DTC Confirmation Procedure has been previously conducted, always perform the following procedure before conducting the next test.

1. Turn ignition switch OFF and wait at least 10 seconds.
2. Turn ignition switch ON.
3. Turn ignition switch OFF and wait at least 10 seconds.

>> GO TO 2.

#### 2. PERFORM DTC CONFIRMATION PROCEDURE

1. Start engine and wait at least 5 seconds.
2. Check 1st trip DTC.

Is 1st trip DTC detected?

YES >> Proceed to [EC-1810, "Diagnosis Procedure"](#).

NO >> INSPECTION END

### Diagnosis Procedure

INFOID:000000007758319

#### 1. CHECK ENGINE OIL TEMPERATURE SENSOR POWER SUPPLY CIRCUIT

1. Disconnect engine oil temperature (EOT) sensor harness connector.
2. Turn ignition switch ON.
3. Check the voltage between EOT sensor harness connector and ground.

| EOT sensor |          | Ground | Voltage (V) |
|------------|----------|--------|-------------|
| Connector  | Terminal |        |             |
| F38        | 1        | Ground | Approx. 5   |

Is the inspection result normal?

YES >> GO TO 2.

NO >> Repair open circuit, short to ground or short to power in harness or connectors.

#### 2. CHECK EOT SENSOR GROUND CIRCUIT FOR OPEN AND SHORT

1. Turn ignition switch OFF.
2. Disconnect ECM harness connector.
3. Check the continuity between EOT sensor harness connector and ECM harness connector.

| EOT sensor |          | ECM       |          | Continuity |
|------------|----------|-----------|----------|------------|
| Connector  | Terminal | Connector | Terminal |            |
| F38        | 2        | F110      | 40       | Existed    |

4. Also check harness for short to ground and short to power.

# P0197, P0198 EOT SENSOR

[VK56VD FOR MEXICO]

## < DTC/CIRCUIT DIAGNOSIS >

### Is the inspection result normal?

YES >> GO TO 3.

NO >> Repair open circuit, short to ground or short to power in harness or connectors.

## 3.CHECK ENGINE OIL TEMPERATURE SENSOR

Refer to [EC-1811, "Component Inspection \(Engine Oil Temperature Sensor\)"](#).

### Is the inspection result normal?

YES >> GO TO 4.

NO >> Replace engine oil temperature sensor. Refer to [EM-226, "Exploded View"](#).

## 4.CHECK INTERMITTENT INCIDENT

Refer to [GI-44, "Intermittent Incident"](#).

>> INSPECTION END

## Component Inspection (Engine Oil Temperature Sensor)

INFOID:000000007758320

## 1.CHECK ENGINE OIL TEMPERATURE SENSOR

1. Turn ignition switch OFF.
2. Disconnect engine oil temperature sensor harness connector.
3. Remove engine oil temperature sensor.
4. Check resistance between engine oil temperature sensor terminals by heating with hot water as shown in the figure.

| Terminals | Condition             | Resistance (kΩ) |               |
|-----------|-----------------------|-----------------|---------------|
| 1 and 2   | Temperature [°C (°F)] | 20 (68)         | 2.1 - 2.9     |
|           |                       | 50 (122)        | 0.68 - 1.00   |
|           |                       | 90 (194)        | 0.236 - 0.260 |

### Is the inspection result normal?

YES >> INSPECTION END

NO >> Replace engine oil temperature sensor.

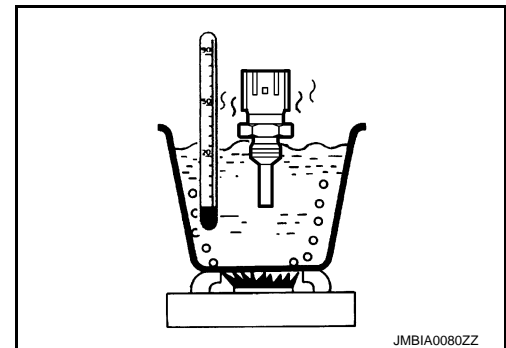

# P0201, P0202, P0203, P0204, P0205, P0206, P0207, P0208 INJECTOR

< DTC/CIRCUIT DIAGNOSIS >

[VK56VD FOR MEXICO]

## P0201, P0202, P0203, P0204, P0205, P0206, P0207, P0208 INJECTOR

### DTC Logic

INFOID:000000007758321

#### DTC DETECTION LOGIC

| DTC No. | Trouble diagnosis name      | DTC detecting condition                                | Possible cause   |
|---------|-----------------------------|--|--|
| P0201   | No.1 fuel injector circuit  | ECM detects No. 1 injector circuit is open or shorted. | <ul style="list-style-type: none"><li>• The fuel injector circuit is open or shorted</li><li>• Fuel injector</li><li>• ECM</li></ul> |
| P0202   | No. 2 fuel injector circuit | ECM detects No. 2 injector circuit is open or shorted. |  |
| P0203   | No. 3 fuel injector circuit | ECM detects No. 3 injector circuit is open or shorted. |  |
| P0204   | No. 4 fuel injector circuit | ECM detects No. 4 injector circuit is open or shorted. |  |
| P0205   | No. 5 fuel injector circuit | ECM detects No. 5 injector circuit is open or shorted. |  |
| P0206   | No. 6 fuel injector circuit | ECM detects No. 6 injector circuit is open or shorted. |  |
| P0207   | No. 7 fuel injector circuit | ECM detects No. 7 injector circuit is open or shorted. |  |
| P0208   | No. 8 fuel injector circuit | ECM detects No. 8 injector circuit is open or shorted. |  |

#### DTC CONFIRMATION PROCEDURE

##### 1. PRECONDITIONING

1. Turn ignition switch OFF and wait at least 10 seconds.
2. Turn ignition switch ON.
3. Turn ignition switch OFF and wait at least 10 seconds.

##### TESTING CONDITION:

Before performing the following procedure, conform that battery voltage is 11 V or more at idle.

>> GO TO 2.

##### 2. PERFORM DTC CONFIRMATION PROCEDURE

1. Turn ignition switch OFF and wait at least 10 seconds.
2. Start the engine and let it idle at least 30 seconds.
3. Check 1st trip DTC.

Is 1st trip DTC detected?

YES >> Proceed to [EC-1812, "Diagnosis Procedure"](#).

NO >> INSPECTION END

#### Diagnosis Procedure

INFOID:000000007758322

##### 1. PERFORM TROUBLE DIAGNOSIS FOR INJECTOR

Refer to [EC-1976, "Component Function Check"](#).

Is inspection result normal?

YES >> Check intermittent incident. Refer to [GI-44, "Intermittent Incident"](#).

NO >> Repair or replace error-detected parts.

# P0222, P0223, P2132, P2133 TP SENSOR

< DTC/CIRCUIT DIAGNOSIS >

[VK56VD FOR MEXICO]

## P0222, P0223, P2132, P2133 TP SENSOR

### DTC Logic

INFOID:000000007758323

#### DTC DETECTION LOGIC

##### NOTE:

If DTC P0222, P0223, P2132 or P2133 is displayed with DTC P0643, first perform the trouble diagnosis for DTC P0643. Refer to [EC-1863, "DTC Logic"](#).

| DTC No. | Trouble diagnosis name<br>(Trouble diagnosis content)                           | DTC detecting condition  | Possible cause   |
|---------|---|--|--|
| P0222   | TP SEN 1/CIRC-B1<br>[Throttle position sensor 1<br>(bank 1) circuit low input]  | An excessively low voltage from the TP sensor 1 is sent to ECM.  | <ul style="list-style-type: none"><li>• Harness or connectors (TP sensor 1 circuit is open or shorted.)</li><li>• Electric throttle control actuator (TP sensor 1)</li></ul> |
| P0223   | TP SEN 1/CIRC-B1<br>[Throttle position sensor 1<br>(bank 1) circuit high input] | An excessively high voltage from the TP sensor 1 is sent to ECM. |  |
| P2132   | TP SEN 1/CIRC-B2<br>[Throttle position sensor 1<br>(bank 2) circuit low input]  | An excessively low voltage from the TP sensor 1 is sent to ECM.  |  |
| P2133   | TP SEN 1/CIRC-B2<br>[Throttle position sensor 1<br>(bank 2) circuit high input] | An excessively high voltage from the TP sensor 1 is sent to ECM. |  |

#### DTC CONFIRMATION PROCEDURE

##### 1. PRECONDITIONING

1. Turn ignition switch OFF and wait at least 10 seconds.
2. Turn ignition switch ON.
3. Turn ignition switch OFF and wait at least 10 seconds.

##### TESTING CONDITION:

Before performing the following procedure, confirm that battery voltage is 10 V or more at idle.

>> GO TO 2.

##### 2. PERFORM DTC CONFIRMATION PROCEDURE

1. Start engine and let it idle for 1 second.
2. Check DTC.

##### Is DTC detected?

YES >> Proceed to [EC-1813, "Diagnosis Procedure"](#).

NO >> INSPECTION END

#### Diagnosis Procedure

INFOID:000000007758324

##### 1. CHECK THROTTLE POSITION SENSOR 1 POWER SUPPLY CIRCUIT-I

1. Disconnect electric throttle control actuator harness connector.
2. Turn ignition switch ON.
3. Check the voltage between electric throttle control actuator harness connector and ground.

| DTC          | Electric throttle control actuator |           |          | Ground | Voltage (V) |
|--------------|------------------------------------|-----------|----------|--------|-------------|
|              | Bank                               | Connector | Terminal |        |             |
| P0222, P0223 | 1                                  | F66       | 2        | Ground | Approx. 5   |
| P2132, P2133 | 2                                  | F64       | 2        |        |             |

##### Is the inspection result normal?

YES >> GO TO 2.

NO >> Repair open circuit, short to ground or short to power in harness or connectors.

## P0222, P0223, P2132, P2133 TP SENSOR

< DTC/CIRCUIT DIAGNOSIS >

[VK56VD FOR MEXICO]

### 2. CHECK THROTTLE POSITION SENSOR 1 GROUND CIRCUIT FOR OPEN AND SHORT

1. Turn ignition switch OFF.
2. Disconnect ECM harness connector.
3. Check the continuity between electric throttle control actuator harness connector and ECM harness connector.

| DTC          | Electric throttle control actuator |           |          | ECM       |          | Continuity |
|--------------|------------------------------------|-----------|----------|-----------|----------|------------|
|              | Bank                               | Connector | Terminal | Connector | Terminal |            |
| P0222, P0223 | 1                                  | F66       | 4        | F111      | 97       | Existed    |
| P2132, P2133 | 2                                  | F64       | 4        |           | 69       |            |

4. Also check harness for short to ground and short to power.

Is the inspection result normal?

YES >> GO TO 3.

NO >> Repair open circuit, short to ground or short to power in harness or connectors.

### 3. CHECK THROTTLE POSITION SENSOR 1 INPUT SIGNAL CIRCUIT FOR OPEN AND SHORT

1. Check the continuity between electric throttle control actuator harness connector and ECM harness connector.

| DTC          | Electric throttle control actuator |           |          | ECM       |          | Continuity |
|--------------|------------------------------------|-----------|----------|-----------|----------|------------|
|              | Bank                               | Connector | Terminal | Connector | Terminal |            |
| P0222, P0223 | 1                                  | F66       | 1        | F111      | 91       | Existed    |
| P2132, P2133 | 2                                  | F64       | 1        |           | 71       |            |

2. Also check harness for short to ground and short to power.

Is the inspection result normal?

YES >> GO TO 4.

NO >> Repair open circuit, short to ground or short to power in harness or connectors.

### 4. CHECK THROTTLE POSITION SENSOR

Refer to [EC-1814, "Component Inspection \(Throttle Position Sensor\)"](#).

Is the inspection result normal?

YES >> GO TO 6.

NO >> GO TO 5.

### 5. REPLACE ELECTRIC THROTTLE CONTROL ACTUATOR

Replace malfunctioning electric throttle control actuator. Refer to [EM-191, "Removal and Installation"](#).

>> INSPECTION END

### 6. CHECK INTERMITTENT INCIDENT

Refer to [GI-44, "Intermittent Incident"](#).

>> INSPECTION END

## Component Inspection (Throttle Position Sensor)

INFOID:000000007758325

### 1. CHECK THROTTLE POSITION SENSOR

1. Turn ignition switch OFF.
2. Reconnect all harness connectors disconnected.
3. Perform [EC-1686, "Work Procedure"](#).
4. Turn ignition switch ON.
5. Set selector lever position to D.
6. Check the voltage between ECM harness connector terminals under the following conditions.

# P0222, P0223, P2132, P2133 TP SENSOR

< DTC/CIRCUIT DIAGNOSIS >

[VK56VD FOR MEXICO]

| ECM       |                              |          | Condition                          | Voltage (V)    |
|-----------|------------------------------|----------|------------------------------------|----------------|
| Connector | +                            | -        |                                    |                |
|           | Terminal                     | Terminal |                                    |                |
| F111      | 91<br>[TP sensor 1 (bank 1)] | 97       | Accelerator pedal: Fully released  | More than 0.36 |
|           |                              |          | Accelerator pedal: Fully depressed | Less than 4.75 |
|           | 71<br>[TP sensor 1 (bank 2)] | 69       | Accelerator pedal: Fully released  | More than 0.36 |
|           |                              |          | Accelerator pedal: Fully depressed | Less than 4.75 |
|           | 79<br>[TP sensor 2 (bank 1)] | 97       | Accelerator pedal: Fully released  | Less than 4.75 |
|           |                              |          | Accelerator pedal: Fully depressed | More than 0.36 |
|           | 89<br>[TP sensor 2 (bank 2)] | 69       | Accelerator pedal: Fully released  | Less than 4.75 |
|           |                              |          | Accelerator pedal: Fully depressed | More than 0.36 |

Is the inspection result normal?

YES >> INSPECTION END

NO >> GO TO 2.

## 2. REPLACE ELECTRIC THROTTLE CONTROL ACTUATOR

Replace malfunctioning electric throttle control actuator. Refer to [EM-191. "Removal and Installation"](#).

>> INSPECTION END

A

EC

C

D

E

F

G

H

I

J

K

L

M

N

O

P

# P0300, P0301, P0302, P0303, P0304, P0305, P0306, P0307, P0308 MISFIRE

< DTC/CIRCUIT DIAGNOSIS >

[VK56VD FOR MEXICO]

## P0300, P0301, P0302, P0303, P0304, P0305, P0306, P0307, P0308 MISFIRE

### DTC Logic

INFOID:000000007758326

#### DTC DETECTION LOGIC

When a misfire occurs, engine speed will fluctuate. If the engine speed fluctuates enough to cause the crankshaft position (CKP) sensor signal to vary, ECM can determine that a misfire is occurring.

| Sensor                     | Input signal to ECM | ECM function                  |
|----------------------------|---------------------|-------------------------------|
| Crankshaft position sensor | Engine speed        | On board diagnosis of misfire |

The misfire detection logic consists of the following two conditions.

#### 1. One Trip Detection Logic (Three Way Catalyst Damage)

On the 1st trip that a misfire condition occurs that can damage the three way catalyst (TWC) due to overheating, the MIL will blink.

When a misfire condition occurs, the ECM monitors the CKP sensor signal every 200 engine revolutions for a change.

When the misfire condition decreases to a level that will not damage the TWC, the MIL will turn off.

If another misfire condition occurs that can damage the TWC on a second trip, the MIL will blink.

When the misfire condition decreases to a level that will not damage the TWC, the MIL will remain on.

If another misfire condition occurs that can damage the TWC, the MIL will begin to blink again.

#### 2. Two Trip Detection Logic (Exhaust quality deterioration)

For misfire conditions that will not damage the TWC (but will affect vehicle emissions), the MIL will only light when the misfire is detected on a second trip. During this condition, the ECM monitors the CKP sensor signal every 1,000 engine revolutions.

A misfire malfunction can be detected in any one cylinder or in multiple cylinders.

| DTC No. | Trouble diagnosis name<br>(Trouble diagnosis content)      | DTC detecting condition     | Possible cause   |
|---------|--|-----------------------------|--|
| P0300   | MULTI CYL MISFIRE<br>(Multiple cylinder misfires detected) | Multiple cylinders misfire. | <ul style="list-style-type: none"><li>• Improper spark plug</li><li>• Insufficient compression</li><li>• Incorrect fuel pressure</li><li>• The fuel injector circuit is open or shorted</li><li>• Fuel injector</li><li>• Intake air leakage</li><li>• The ignition signal circuit is open or shorted</li><li>• Lack of fuel</li><li>• Signal plate</li><li>• A/F sensor 1</li><li>• Incorrect PCV hose connection</li></ul> |
| P0301   | CYL 1 MISFIRE<br>(No.1 cylinder misfire detected)          | No. 1 cylinder misfires.    |  |
| P0302   | CYL 2 MISFIRE<br>(No. 2 cylinder misfire detected)         | No. 2 cylinder misfires.    |  |
| P0303   | CYL 3 MISFIRE<br>(No. 3 cylinder misfire detected)         | No. 3 cylinder misfires.    |  |
| P0304   | CYL 4 MISFIRE<br>(No. 4 cylinder misfire detected)         | No. 4 cylinder misfires.    |  |
| P0305   | CYL 5 MISFIRE<br>(No. 5 cylinder misfire detected)         | No. 5 cylinder misfires.    |  |
| P0306   | CYL 6 MISFIRE<br>(No. 6 cylinder misfire detected)         | No. 6 cylinder misfires.    |  |
| P0307   | CYL 7 MISFIRE<br>(No. 7 cylinder misfire detected)         | No. 7 cylinder misfires.    |  |
| P0308   | CYL 8 MISFIRE<br>(No. 8 cylinder misfire detected)         | No. 8 cylinder misfires.    |  |

#### DTC CONFIRMATION PROCEDURE

##### 1. PRECONDITIONING

If DTC Confirmation Procedure has been previously conducted, always perform the following procedure before conducting the next test.

1. Turn ignition switch OFF and wait at least 10 seconds.
2. Turn ignition switch ON.
3. Turn ignition switch OFF and wait at least 10 seconds.



>> GO TO 2.

**2.PERFORM DTC CONFIRMATION PROCEDURE-I**

1. Start engine and warm it up to normal operating temperature.
2. Turn ignition switch OFF and wait at least 10 seconds.
3. Turn ignition switch ON.
4. Turn ignition switch OFF and wait at least 10 seconds.
5. Restart engine and let it idle for about 15 minutes.
6. Check 1st trip DTC.

Is 1st trip DTC detected?

- YES >> Proceed to [EC-1817, "Diagnosis Procedure"](#).  
 NO >> GO TO 3.

**3.PERFORM DTC CONFIRMATION PROCEDURE-II**

1. Turn ignition switch OFF and wait at least 10 seconds.
2. Turn ignition switch ON.
3. Turn ignition switch OFF and wait at least 10 seconds.
4. Start engine and drive the vehicle under similar conditions to (1st trip) Freeze Frame Data for a certain time. Refer to the table below.

**Hold the accelerator pedal as steady as possible.**

Similar conditions to (1st trip) Freeze Frame Data mean that the following conditions should be satisfied at the same time.

**CAUTION:**

**Always drive vehicle in safe manner according to traffic conditions and obey all traffic laws when driving.**

|  |  |
|--|--|
| Engine speed                             | Engine speed in the freeze frame data ± 400 rpm  |
| Vehicle speed                            | Vehicle speed in the freeze frame data ± 10 km/h (6 MPH)   |
| Base fuel schedule                       | Base fuel schedule in the freeze frame data × (1 ± 0.1)  |
| Engine coolant temperature (T) condition | When the freeze frame data shows lower than 70°C (158°F), T should be lower than 70°C (158°F).                           |
|  | When the freeze frame data shows higher than or equal to 70°C (158°F), T should be higher than or equal to 70°C (158°F). |

Driving time varies according to the engine speed in the freeze frame data.

| Engine speed        | Time                      |
|---------------------|---------------------------|
| Around 1,000 rpm    | Approximately 10 minutes  |
| Around 2,000 rpm    | Approximately 5 minutes   |
| More than 3,000 rpm | Approximately 3.5 minutes |

5. Check 1st trip DTC.

Is 1st trip DTC detected?

- YES >> Proceed to [EC-1817, "Diagnosis Procedure"](#).  
 NO >> INSPECTION END

**Diagnosis Procedure**

INFOID:000000007758327

**1.CHECK FOR INTAKE AIR LEAKAGE AND PCV HOSE**

1. Start engine and run it at idle speed.
2. Listen for the sound of the intake air leakage.
3. Check PCV hose connection.

Is intake air leakage detected?

- YES >> Discover air leakage location and repair.  
 NO >> GO TO 2.

# P0300, P0301, P0302, P0303, P0304, P0305, P0306, P0307, P0308 MISFIRE

< DTC/CIRCUIT DIAGNOSIS >

[VK56VD FOR MEXICO]

## 2. CHECK FOR EXHAUST SYSTEM CLOGGING

Stop engine and visually check exhaust tube, three way catalyst and muffler for dents.

Is the inspection result normal?

- YES-1 >> With CONSULT: GO TO 3.
- YES-2 >> Without CONSULT: GO TO 4.
- NO >> Repair or replace malfunctioning part.

## 3. PERFORM POWER BALANCE TEST

Ⓟ WITH CONSULT

1. Start engine.
2. Perform "POWER BALANCE" in "ACTIVE TEST" mode with CONSULT.
3. Check that each circuit produces a momentary engine speed drop.

Is the inspection result normal?

- YES >> GO TO 9.
- NO >> GO TO 4.

## 4. CHECK FUNCTION OF FUEL INJECTOR-I

1. Start engine and let it idle.
2. Listen to each fuel injector operation.

**Clicking sound should be heard.**

Is the inspection result normal?

- YES >> GO TO 5.
- NO >> Perform trouble diagnosis for fuel injector, refer to [EC-1976, "Diagnosis Procedure"](#).

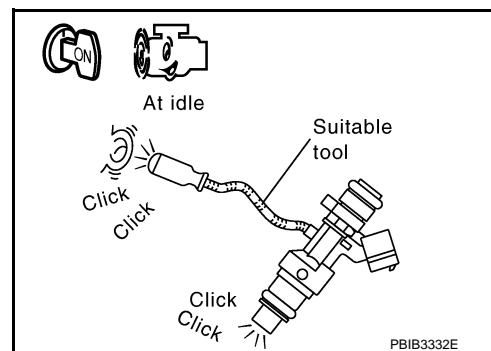

## 5. CHECK FUNCTION OF IGNITION COIL-I

### CAUTION:

Perform the following procedure in a place with no combustible objects and good ventilation.

1. Turn ignition switch OFF.
2. Remove fuel pump fuse No. in IPDM E/R to release fuel pressure.

### NOTE:

Do not use CONSULT to release fuel pressure, or fuel pressure applies again during the following procedure.

3. Start engine.
4. After engine stalls, crank it 2 or 3 times to release all fuel pressure.
5. Turn ignition switch OFF.
6. Remove all ignition coil harness connectors to avoid the electrical discharge from the ignition coils.
7. Remove ignition coil and spark plug of the cylinder to be checked.
8. Crank engine for 5 seconds or more to remove combustion gas in the cylinder.
9. Connect spark plug and harness connector to ignition coil.
10. Fix ignition coil using a rope etc. with gap of 13 - 17 mm (0.52 - 0.66 in) between the edge of the spark plug and grounded metal portion as shown in the figure.
11. Crank engine for approximately 3 seconds, and check whether spark is generated between the spark plug and the grounded metal portion.

**Spark should be generated.**

### CAUTION:

- Never place the spark plug and the ignition coil within 50 cm (19.7 in) each other. Be careful not to get an electrical shock while checking, because the electrical discharge voltage becomes 20 kV or more.

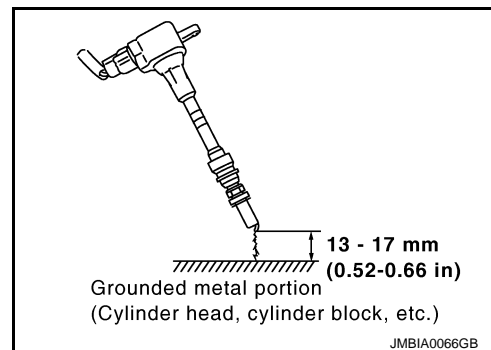

# P0300, P0301, P0302, P0303, P0304, P0305, P0306, P0307, P0308 MISFIRE

< DTC/CIRCUIT DIAGNOSIS >

[VK56VD FOR MEXICO]

- It might damage the ignition coil if the gap of more than 17 mm (0.66 in) is made.

## NOTE:

When the gap is less than 13 mm (0.52 in), a spark might be generated even if the coil is malfunctioning.

Is the inspection result normal?

YES >> GO TO 9.

NO >> GO TO 6.

## 6. CHECK FUNCTION OF IGNITION COIL-II

1. Turn ignition switch OFF.
2. Disconnect spark plug and connect a non-malfunctioning spark plug.
3. Crank engine for approximately 3 seconds, and recheck whether spark is generated between the spark plug and the grounded metal portion.

**Spark should be generated.**

Is the inspection result normal?

YES >> GO TO 7.

NO >> Check ignition coil, power transistor and their circuits. Refer to [EC-1984, "Diagnosis Procedure"](#).

## 7. CHECK SPARK PLUG

Check the initial spark plug for fouling, etc.

Is the inspection result normal?

YES >> Replace spark plug(s) with standard type one(s). For spark plug type, refer to [EM-301, "Spark Plug"](#).

NO >> Repair or clean spark plug. Then GO TO 8.

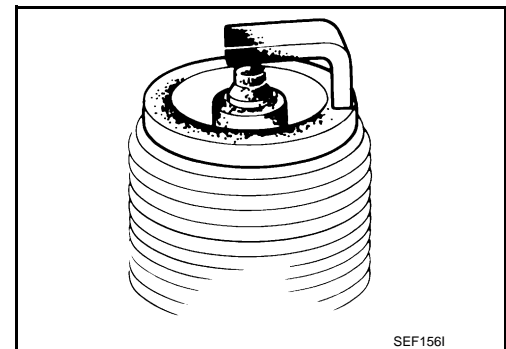

## 8. CHECK FUNCTION OF IGNITION COIL-III

1. Reconnect the initial spark plugs.
2. Crank engine for approximately 3 seconds, and recheck whether spark is generated between the spark plug and the grounded portion.

**Spark should be generated.**

Is the inspection result normal?

YES >> INSPECTION END

NO >> Replace spark plug(s) with standard type one(s). For spark plug type, refer to [EM-301, "Spark Plug"](#).

## 9. CHECK COMPRESSION PRESSURE

Check compression pressure. Refer to [EM-172, "Inspection"](#).

Is the inspection result normal?

YES >> GO TO 10.

NO >> Check pistons, piston rings, valves, valve seats and cylinder head gaskets.

## 10. CHECK FUEL PRESSURE

1. Install all removed parts.
2. Check fuel pressure. Refer to [EC-1692, "Work Procedure"](#).

Is the inspection result normal?

YES >> GO TO 12.

NO >> GO TO 11.

## 11. DETECT MALFUNCTIONING PART

# P0300, P0301, P0302, P0303, P0304, P0305, P0306, P0307, P0308 MISFIRE

< DTC/CIRCUIT DIAGNOSIS >

[VK56VD FOR MEXICO]

Check fuel hoses and fuel tubes for clogging.

Is the inspection result normal?

YES >> Replace "fuel filter and fuel pump assembly". Refer to [FL-6. "Removal and Installation"](#).

NO >> Repair or replace malfunctioning part.

## 12.CHECK IDLE SPEED AND IGNITION TIMING

Check idle speed and ignition timing.

- Idle speed: For procedure, refer to [EC-2009. "Inspection"](#). For specification, refer to [EC-2016. "Idle Speed"](#)
- Ignition timing: For procedure, refer to [EC-2010. "Inspection"](#). For specification, refer to [EC-2016. "Ignition Timing"](#).

Is the inspection result normal?

YES >> GO TO 13.

NO >> Perform basic inspection. Refer to [EC-1679. "Work Procedure"](#).

## 13.CHECK A/F SENSOR 1 INPUT SIGNAL CIRCUIT

1. Turn ignition switch OFF.
2. Disconnect corresponding A/F sensor 1 harness connector.
3. Disconnect ECM harness connector.
4. Check the continuity between A/F sensor 1 harness connector and ECM harness connector.

| A/F sensor 1 |           |          | ECM       |          | Continuity |
|--------------|-----------|----------|-----------|----------|------------|
| Bank         | Connector | Terminal | Connector | Terminal |            |
| 1            | F23       | 3        | F111      | 88       | Existed    |
|              |           | 4        |           | 90       |            |
|              |           | 6        |           | 94       |            |
| 2            | F24       | 3        |           | 78       |            |
|              |           | 4        |           | 80       |            |
|              |           | 6        |           | 74       |            |

5. Check the continuity between A/F sensor 1 harness connector and ground, or ECM harness connector and ground.

| A/F sensor 1 |           |          | ECM       |          | Ground | Continuity |
|--------------|-----------|----------|-----------|----------|--------|------------|
| Bank         | Connector | Terminal | Connector | Terminal |        |            |
| 1            | F23       | 3        | F111      | 88       | Ground | Existed    |
|              |           | 4        |           | 90       |        |            |
|              |           | 6        |           | 94       |        |            |
| 2            | F24       | 3        |           | 78       |        |            |
|              |           | 4        |           | 80       |        |            |
|              |           | 6        |           | 74       |        |            |

6. Also check harness for short to power.

Is the inspection result normal?

YES >> GO TO 14.

NO >> Repair open circuit, short to ground or short to power in harness or connectors.

## 14.CHECK A/F SENSOR 1 HEATER

Refer to [EC-1726. "Component Inspection \(A/F Sensor 1 Heater\)"](#).

Is the inspection result normal?

YES >> GO TO 15.

NO >> Replace malfunctioning A/F sensor 1. Refer to [EM-223. "Exploded View"](#).

## 15.CHECK MASS AIR FLOW SENSOR

Ⓜ WITH CONSULT

# P0300, P0301, P0302, P0303, P0304, P0305, P0306, P0307, P0308 MISFIRE

[VK56VD FOR MEXICO]

## < DTC/CIRCUIT DIAGNOSIS >

Check mass air flow sensor signal in "DATA MONITOR" mode with CONSULT.

For specification, refer to [EC-2016, "Mass Air Flow Sensor"](#).

 WITH GST

Check mass air flow sensor signal in Service \$01 with GST.

For specification, refer to [EC-2016, "Mass Air Flow Sensor"](#).

Is the measurement value within the specification?

YES >> GO TO 16.

NO >> Check connectors for rusted terminals or loose connections in the mass air flow sensor circuit or ground. Refer to [EC-1750, "Diagnosis Procedure"](#).

## 16.CHECK SYMPTOM MATRIX CHART

Check items on the rough idle symptom in [EC-2003, "Symptom Table"](#).



Is the inspection result normal?

YES >> GO TO 17.

NO >> Repair or replace malfunctioning part.

## 17.ERASE THE 1ST TRIP DTC

Some tests may cause a 1st trip DTC to be set.

Erase the 1st trip DTC from the ECM memory after performing the tests. Refer to  [EC-1615, "CONSULT Function"](#) or  [EC-1612, "On Board Diagnosis Function"](#).

>> GO TO 18.

## 18.CHECK INTERMITTENT INCIDENT

Refer to [GI-44, "Intermittent Incident"](#).

>> INSPECTION END

A

EC

C

D

E

F

G

H

I

J

K

L

M

N

O

P

P0327, P0328, P0332, P0333 KS

DTC Logic

INFOID:000000007758328

DTC DETECTION LOGIC

| DTC No. | Trouble diagnosis name<br>(Trouble diagnosis content)           | DTC detected condition                                      | Possible cause   |
|---------|---|---|--|
| P0327   | KNOCK SEN/CIRC-B1<br>[Knock sensor (bank 1) circuit low input]  | An excessively low voltage from the sensor is sent to ECM.  | <ul style="list-style-type: none"> <li>• Harness or connectors (The knock sensor circuit is open or shorted.)</li> <li>• Knock sensor</li> </ul> |
| P0328   | KNOCK SEN/CIRC-B1<br>[Knock sensor (bank 1) circuit high input] | An excessively high voltage from the sensor is sent to ECM. |  |
| P0332   | KNOCK SEN/CIRC-B2<br>[Knock sensor (bank 2) circuit low input]  | An excessively low voltage from the sensor is sent to ECM.  |  |
| P0333   | KNOCK SEN/CIRC-B2<br>[Knock sensor (bank 2) circuit high input] | An excessively high voltage from the sensor is sent to ECM. |  |

DTC CONFIRMATION PROCEDURE

1. PRECONDITIONING

1. Turn ignition switch OFF and wait at least 10 seconds.
2. Turn ignition switch ON.
3. Turn ignition switch OFF and wait at least 10 seconds.

**TESTING CONDITION:**

Before performing the following procedure, confirm that battery voltage is 10 V or more at idle.

>> GO TO 2.

2. PERFORM DTC CONFIRMATION PROCEDURE

1. Start engine and run it for at least 5 seconds at idle speed.
2. Check 1st trip DTC.

Is 1st trip DTC detected?

- YES >> Proceed to [EC-1822, "Diagnosis Procedure"](#).  
 NO >> INSPECTION END

Diagnosis Procedure

INFOID:000000007758329

1. CHECK KNOCK SENSOR GROUND CIRCUIT FOR OPEN AND SHORT

1. Disconnect knock sensor harness connector and ECM harness connector.
2. Check the continuity between knock sensor harness connector and ECM harness connector.

| DTC          | Knock sensor |           |          | ECM       |          | Continuity |
|--------------|--------------|-----------|----------|-----------|----------|------------|
|              | Bank         | Connector | Terminal | Connector | Terminal |            |
| P0327, P0328 | 1            | F212      | 2        | F110      | 35       | Existed    |
| P0332, P0333 | 2            | F213      | 2        |           |          |            |

3. Also check harness for short to ground and short to power.

Is the inspection result normal?

- YES >> GO TO 3.  
 NO >> GO TO 2.

2. DETECT MALFUNCTIONING PART

Check the following.

- Harness for open or short between knock sensor and ECM
- Loose or poor connection for each connector and harness

>> Repair open circuit or short to power in harness or connectors.

### 3.CHECK KNOCK SENSOR INPUT SIGNAL CIRCUIT FOR OPEN AND SHORT

1. Check the continuity between knock sensor harness connector and ECM harness connector.

| DTC          | Knock sensor |           |          | ECM       |          | Continuity |
|--------------|--------------|-----------|----------|-----------|----------|------------|
|              | Bank         | Connector | Terminal | Connector | Terminal |            |
| P0327, P0328 | 1            | F212      | 1        | F110      | 29       | Existed    |
| P0332, P0333 | 2            | F213      | 1        |           | 33       |            |

2. Also check harness for short to ground and short to power.

Is the inspection result normal?

- YES >> GO TO 5.
- NO >> GO TO 4.

### 4.DETECT MALFUNCTIONING PART

Check the following.

- Harness for open or short between ECM and knock sensor
- Loose or poor connection for each connector and harness

>> Repair open circuit, short to ground or short to power in harness or connectors.

### 5.CHECK KNOCK SENSOR

Refer to [EC-1823. "Component Inspection \(Knock Sensor\)"](#).

Is the inspection result normal?

- YES >> GO TO 6.
- NO >> Replace malfunctioning knock sensor. Refer to [EM-274. "Exploded View"](#).

### 6.CHECK INTERMITTENT INCIDENT

Refer to [GI-44. "Intermittent Incident"](#).

>> INSPECTION END

## Component Inspection (Knock Sensor)

INFOID:000000007758330

### 1.CHECK KNOCK SENSOR

1. Turn ignition switch OFF.
2. Disconnect knock sensor harness connector.
3. Check resistance between knock sensor terminals as per the following.

**NOTE:**

**It is necessary to use an ohmmeter which can measure more than 10 MΩ.**

| Terminals | Resistance                            |
|-----------|---------------------------------------|
| 1 and 2   | Approx. 532 - 588 kΩ [at 20°C (68°F)] |

**CAUTION:**

**Never use any knock sensors that have been dropped or physically damaged. Use only new ones.**

Is the inspection result normal?

- YES >> INSPECTION END
- NO >> Replace malfunctioning knock sensor. Refer to [EM-274. "Exploded View"](#).

# P0335 CKP SENSOR

[VK56VD FOR MEXICO]

< DTC/CIRCUIT DIAGNOSIS >

## P0335 CKP SENSOR

### DTC Logic

INFOID:000000007758331

### DTC DETECTION LOGIC

| DTC No. | Trouble diagnosis name<br>(Trouble diagnosis content)   | DTC detecting condition   | Possible cause  |
|---------|---|---|---|
| P0335   | CKP SEN/CIRCUIT<br>(Crankshaft position sensor circuit) | <ul style="list-style-type: none"> <li>The crankshaft position sensor signal is not detected by the ECM during the first few seconds of engine cranking.</li> <li>The proper pulse signal from the crankshaft position sensor is not sent to ECM while the engine is running.</li> <li>The crankshaft position sensor signal is not in the normal pattern during engine running.</li> </ul> | <ul style="list-style-type: none"> <li>Harness or connectors<br/>(Crankshaft position sensor circuit is open or shorted.)<br/>[Camshaft position sensor (bank 1) circuit is shorted.]<br/>(Accelerator pedal position sensor 2 circuit is shorted.)<br/>(Battery current sensor circuit is shorted.)<br/>(EVAP control system pressure sensor circuit is shorted.)<br/>(Refrigerant pressure sensor circuit is shorted.)</li> <li>Crankshaft position sensor</li> <li>Camshaft position sensor (bank 1)</li> <li>Accelerator pedal position sensor 2</li> <li>Battery current sensor</li> <li>EVAP control system pressure sensor</li> <li>Refrigerant pressure sensor</li> <li>Signal plate</li> </ul> |

### DTC CONFIRMATION PROCEDURE

#### 1. PRECONDITIONING

- Turn ignition switch OFF and wait at least 10 seconds.
- Turn ignition switch ON.
- Turn ignition switch OFF and wait at least 10 seconds.

#### TESTING CONDITION:

**Before performing the following procedure, confirm that battery voltage is 10.5 V or more with ignition switch ON.**

>> GO TO 2.

#### 2. PERFORM DTC CONFIRMATION PROCEDURE

- Start engine and let it idle for at least 5 seconds.  
If engine does not start, crank engine for at least 2 seconds.
- Check 1st trip DTC.

Is 1st trip DTC detected?

- YES >> Proceed to [EC-1824, "Diagnosis Procedure"](#).  
NO >> INSPECTION END

### Diagnosis Procedure

INFOID:000000007758332

#### 1. CHECK CRANKSHAFT POSITION SENSOR POWER SUPPLY CIRCUIT-I

- Disconnect crankshaft position (CKP) sensor harness connector.
- Turn ignition switch ON.
- Check the voltage between CKP sensor harness connector and ground.

| CKP sensor |          | Ground | Voltage (V) |
|------------|----------|--------|-------------|
| Connector  | Terminal |        |             |
| F2         | 1        | Ground | Approx. 5 V |



# P0335 CKP SENSOR

[VK56VD FOR MEXICO]

## < DTC/CIRCUIT DIAGNOSIS >

Is the inspection result normal?

YES >> GO TO 7.

NO >> GO TO 2.

### 2.CHECK CKP SENSOR POWER SUPPLY CIRCUIT-II

1. Turn ignition switch ON.
2. Disconnect ECM harness connector.
3. Check the continuity between CKP sensor harness connector and ECM harness connector.

| CKP sensor |          | ECM       |          | Continuity |
|------------|----------|-----------|----------|------------|
| Connector  | Terminal | Connector | Terminal |            |
| F2         | 1        | F111      | 76       | Existed    |

Is the inspection result normal?

YES >> GO TO 3.

NO >> Repair open circuit.

### 3.CHECK SENSOR POWER SUPPLY CIRCUIT

Check harness for short to power and short to ground, between the following terminals.

| ECM       |          | Sensor                              |           |          |
|-----------|----------|-------------------------------------|-----------|----------|
| Connector | Terminal | Name                                | Connector | Terminal |
| F111      | 76       | CKP sensor                          | F2        | 1        |
|           | 77       | Camshaft position sensor (bank 1)   | F84       | 1        |
| M160      | 133      | Battery current sensor              | E21       | 1        |
|           | 133      | EVAP control system pressure sensor | B73       | 3        |
|           | 133      | Refrigerant pressure sensor         | E77       | 3        |
|           | 137      | APP sensor 2 (Without ICC)          | M9        | 5        |
|           | 137      | APP sensor 2 (With ICC)             | M153      | 6        |

Is the inspection result normal?

YES >> GO TO 4.

NO >> Repair short to ground or short to power in harness or connectors.

### 4.CHECK COMPONENTS

Check the following.

- Camshaft position sensor (bank 1) (Refer to [EC-1831, "Component Inspection \(Camshaft Position Sensor\)"](#).)
- Battery current sensor (Refer to [EC-1906, "Component Inspection \(Battery Current Sensor\)"](#).)
- EVAP control system pressure sensor (Refer to [EC-1974, "Component Inspection \(EVAP Control System Pressure Sensor\)"](#).)
- Refrigerant pressure sensor (Refer to [EC-2001, "Diagnosis Procedure"](#).)

Is the inspection result normal?

YES >> GO TO 5.

NO >> Replace malfunctioning component.

### 5.CHECK APP SENSOR

Refer to [EC-1952, "Component Inspection \(Accelerator Pedal Position Sensor\)"](#).

Is the inspection result normal?

YES >> GO TO 11.

NO >> GO TO 6.

### 6.REPLACE ACCELERATOR PEDAL ASSEMBLY

Replace accelerator pedal assembly. Refer to following.

- Models with Distance Control Assist system: [ACC-4, "MODELS WITH DISTANCE CONTROL ASSIST SYSTEM : Removal and Installation"](#)

# P0335 CKP SENSOR

[VK56VD FOR MEXICO]

< DTC/CIRCUIT DIAGNOSIS >

- Models without Distance Control Assist system: [ACC-3. "MODELS WITHOUT DISTANCE CONTROL ASSIST SYSTEM : Removal and Installation"](#)

>> INSPECTION END

## 7. CHECK CKP SENSOR GROUND CIRCUIT FOR OPEN AND SHORT

- Turn ignition switch OFF.
- Disconnect ECM harness connector.
- Check the continuity between CKP sensor harness connector and ECM harness connector.

| CKP sensor |          | ECM       |          | Continuity |
|------------|----------|-----------|----------|------------|
| Connector  | Terminal | Connector | Terminal |            |
| F2         | 2        | F111      | 98       | Existed    |

- Also check harness for short to ground and short to power.

Is the inspection result normal?

YES >> GO TO 8.

NO >> Repair open circuit, short to ground or short to power in harness or connectors.

## 8. CHECK CKP SENSOR INPUT SIGNAL CIRCUIT FOR OPEN AND SHORT

- Check the continuity between CKP sensor harness connector and ECM harness connector.

| CKP sensor |          | ECM       |          | Continuity |
|------------|----------|-----------|----------|------------|
| Connector  | Terminal | Connector | Terminal |            |
| F2         | 3        | F111      | 86       | Existed    |

- Also check harness for short to ground and short to power.

Is the inspection result normal?

YES >> GO TO 9.

NO >> Repair open circuit, short to ground or short to power in harness or connectors.

## 9. CHECK CRANKSHAFT POSITION SENSOR

Refer to [EC-1826. "Component Inspection \(Crankshaft Position Sensor\)"](#).

Is the inspection result normal?

YES >> GO TO 10.

NO >> Replace crankshaft position sensor. Refer to [EM-226. "Exploded View"](#).

## 10. CHECK GEAR TOOTH

Visually check for chipping signal plate gear tooth.

Is the inspection result normal?

YES >> GO TO 11.

NO >> Replace the signal plate. Refer to [EM-274. "Exploded View"](#)

## 11. CHECK INTERMITTENT INCIDENT

Refer to [GI-44. "Intermittent Incident"](#).

>> INSPECTION END

## Component Inspection (Crankshaft Position Sensor)

INFOID:000000007758333

### 1. CHECK CRANKSHAFT POSITION SENSOR-I

- Turn ignition switch OFF.
- Loosen the fixing bolt of the sensor.
- Disconnect crankshaft position sensor harness connector.
- Remove the sensor.

# P0335 CKP SENSOR

[VK56VD FOR MEXICO]

## < DTC/CIRCUIT DIAGNOSIS >

5. Visually check the sensor for chipping.

Is the inspection result normal?

YES >> GO TO 2.

NO >> Replace crankshaft position sensor. Refer to [EM-226](#), "[Exploded View](#)".

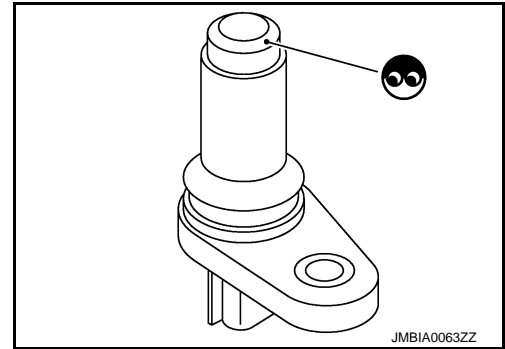

## 2. CHECK CRANKSHAFT POSITION SENSOR-II

Check resistance between crankshaft position sensor terminals as per the following.

| Terminals (Polarity) | Resistance                                     |
|----------------------|--|
| 1 (+) - 2 (-)        | Except 0 or $\infty$ $\Omega$ [at 25°C (77°F)] |
| 1 (+) - 3 (-)        |  |
| 2 (+) - 3 (-)        |  |

Is the inspection result normal?

YES >> INSPECTION END

NO >> Replace crankshaft position sensor. Refer to [EM-226](#), "[Exploded View](#)".

A

EC

C

D

E

F

G

H

I

J

K

L

M

N

O

P

# P0340, P0345 CMP SENSOR

< DTC/CIRCUIT DIAGNOSIS >

[VK56VD FOR MEXICO]

## P0340, P0345 CMP SENSOR

### DTC Logic

INFOID:000000007758334

### DTC DETECTION LOGIC

#### NOTE:

If DTC P0345 is displayed with DTC P0643, first perform the trouble diagnosis for DTC P0643. Refer to [EC-1863, "DTC Logic"](#).

| DTC No. | Trouble diagnosis name<br>(Trouble diagnosis content)             | DTC detecting condition  | Possible cause   |
|---------|---|--|--|
| P0340   | CMP SEN/CIRC-B1<br>[Camshaft position sensor<br>(bank 1) circuit] | <ul style="list-style-type: none"> <li>The cylinder No. signal is not sent to ECM for the first few seconds during engine cranking.</li> <li>The cylinder No. signal is not sent to ECM during engine running.</li> <li>The cylinder No. signal is not in the normal pattern during engine running.</li> </ul> | <ul style="list-style-type: none"> <li>Harness or connectors<br/>[Camshaft position sensor (bank 1) circuit is shorted.]<br/>(Crankshaft position sensor circuit is open or shorted.)<br/>(Accelerator pedal position sensor 2 circuit is shorted.)<br/>(Battery current sensor circuit is shorted.)<br/>(EVAP control system pressure sensor circuit is shorted.)<br/>(Refrigerant pressure sensor circuit is shorted.)</li> <li>Camshaft position sensor (bank 1)</li> <li>Crankshaft position sensor</li> <li>Accelerator pedal position sensor 2</li> <li>Battery current sensor</li> <li>EVAP control system pressure sensor</li> <li>Refrigerant pressure sensor</li> <li>Camshaft (INT)</li> <li>Starter motor</li> <li>Starting system circuit</li> <li>Dead (Weak) battery</li> </ul> |
| P0345   | Camshaft position sensor<br>(bank 2) circuit<br>(CMP SEN/CIRC-B2) |  | <ul style="list-style-type: none"> <li>Harness or connectors<br/>[Camshaft position sensor (bank 2) circuit is open or shorted.]</li> <li>Camshaft position sensor (bank 2)</li> <li>Camshaft (INT)</li> <li>Starter motor</li> <li>Starting system circuit</li> <li>Dead (Weak) battery</li> </ul>  |

### DTC CONFIRMATION PROCEDURE

#### 1. PRECONDITIONING

- Turn ignition switch OFF and wait at least 10 seconds.
- Turn ignition switch ON.
- Turn ignition switch OFF and wait at least 10 seconds.

#### TESTING CONDITION:

Before performing the following procedure, confirm that battery voltage is 10.5 V or more with ignition switch ON.

>> GO TO 2.

#### 2. PERFORM DTC CONFIRMATION PROCEDURE-I

- Start engine and let it idle for at least 5 seconds.  
If engine does not start, crank engine for at least 2 seconds.
- Check 1st trip DTC.

#### Is 1st trip DTC detected?

- YES >> Proceed to [EC-1829, "Diagnosis Procedure"](#).  
NO >> GO TO 3.

# P0340, P0345 CMP SENSOR

[VK56VD FOR MEXICO]

< DTC/CIRCUIT DIAGNOSIS >

## 3.PERFORM DTC CONFIRMATION PROCEDURE-I

1. Maintain engine speed at more than 800 rpm for at least 5 seconds.
2. Check 1st trip DTC.

Is 1st trip DTC detected?

- YES >> Proceed to [EC-1829, "Diagnosis Procedure"](#).  
NO >> INSPECTION END

## Diagnosis Procedure

INFOID:000000007758335

### 1.CHECK STARTING SYSTEM

Turn ignition switch to START position.

Does the engine turn over? Does the starter motor operate?

- YES >> GO TO 2.  
NO >> Check starting system. Refer to [STR-9, "Work Flow"](#).

### 2.CHECK CAMSHAFT POSITION SENSOR POWER SUPPLY CIRCUIT-I

1. Disconnect camshaft position (CMP) sensor harness connector.
2. Turn ignition switch ON.
3. Check the voltage between CMP sensor harness connector and ground.

| DTC   | CMP sensor |           |          | Ground | Voltage (V) |
|-------|------------|-----------|----------|--------|-------------|
|       | Bank       | Connector | Terminal |        |             |
| P0340 | 1          | F84       | 1        | Ground | Approx. 5   |
| P0345 | 2          | F83       | 1        |        |             |

Is the inspection result normal?

- YES >> GO TO 8.  
NO-1 >> P0340: GO TO 3.  
NO-2 >> P0345: Repair open circuit, short to ground or short to power in harness or connectors.

### 3.CHECK CMP SENSOR POWER SUPPLY CIRCUIT-II

1. Turn ignition switch OFF.
2. Disconnect ECM harness connector.
3. Check the continuity between CMP sensor harness connector and ECM harness connector.

| CMP sensor |           |          | ECM       |          | Continuity |
|------------|-----------|----------|-----------|----------|------------|
| Bank       | Connector | Terminal | Connector | Terminal |            |
| 1          | F84       | 1        | F111      | 77       | Existed    |

Is the inspection result normal?

- YES >> GO TO 4.  
NO >> Repair open circuit.

### 4.CHECK SENSOR POWER SUPPLY CIRCUIT

Check harness for short to power and short to ground, between the following terminals.

| ECM       |          | Sensor                            |           |          |
|-----------|----------|-----------------------------------|-----------|----------|
| Connector | Terminal | Name                              | Connector | Terminal |
| F111      | 76       | CKP sensor                        | F2        | 1        |
|           | 77       | Camshaft position sensor (bank 1) | F84       | 1        |

# P0340, P0345 CMP SENSOR

< DTC/CIRCUIT DIAGNOSIS >

[VK56VD FOR MEXICO]

| ECM       |          | Sensor                              |           |          |
|-----------|----------|-------------------------------------|-----------|----------|
| Connector | Terminal | Name                                | Connector | Terminal |
| M160      | 133      | Battery current sensor              | E21       | 1        |
|           | 133      | EVAP control system pressure sensor | B73       | 3        |
|           | 133      | Refrigerant pressure sensor         | E77       | 3        |
|           | 137      | APP sensor 2 (Without ICC)          | M9        | 5        |
|           | 137      | APP sensor 2 (With ICC)             | M153      | 6        |

Is the inspection result normal?

YES >> GO TO 5.

NO >> Repair short to ground or short to power in harness or connectors.

## 5. CHECK COMPONENTS

Check the following.

- CKP sensor (Refer to [EC-1826, "Component Inspection \(Crankshaft Position Sensor\)"](#).)
- Camshaft position sensor (bank 1) (Refer to [EC-1831, "Component Inspection \(Camshaft Position Sensor\)"](#).)
- Battery current sensor (Refer to [EC-1906, "Component Inspection \(Battery Current Sensor\)"](#).)
- EVAP control system pressure sensor (Refer to [EC-1974, "Component Inspection \(EVAP Control System Pressure Sensor\)"](#).)
- Refrigerant pressure sensor (Refer to [EC-2001, "Diagnosis Procedure"](#).)

Is the inspection result normal?

YES >> GO TO 6.

NO >> Replace malfunctioning component.

## 6. CHECK APP SENSOR

Refer to [EC-1952, "Component Inspection \(Accelerator Pedal Position Sensor\)"](#).

Is the inspection result normal?

YES >> GO TO 12.

NO >> GO TO 7.

## 7. REPLACE ACCELERATOR PEDAL ASSEMBLY

Replace accelerator pedal assembly. Refer to following.

- Models without Distance Control Assist system: [ACC-3, "MODELS WITHOUT DISTANCE CONTROL ASSIST SYSTEM : Removal and Installation"](#)
- Models with Distance Control Assist system: [ACC-4, "MODELS WITH DISTANCE CONTROL ASSIST SYSTEM : Removal and Installation"](#)

>> INSPECTION END

## 8. CHECK CMP SENSOR GROUND CIRCUIT FOR OPEN AND SHORT

1. Turn ignition switch OFF.
2. Disconnect ECM harness connector.
3. Check the continuity between CMP sensor harness connector and ECM harness connector.

| DTC   | CMP sensor |           |          | ECM       |          | Continuity |
|-------|------------|-----------|----------|-----------|----------|------------|
|       | Bank       | Connector | Terminal | Connector | Terminal |            |
| P0340 | 1          | F84       | 2        | F111      | 68       | Existed    |
| P0345 | 2          | F83       | 2        |           | 99       |            |

4. Also check harness for short to ground and short to power.

Is the inspection result normal?

YES >> GO TO 9.

NO >> Repair open circuit, short to ground or short to power in harness or connectors.

## 9. CHECK CMP SENSOR INPUT SIGNAL CIRCUIT FOR OPEN AND SHORT

# P0340, P0345 CMP SENSOR

[VK56VD FOR MEXICO]

## < DTC/CIRCUIT DIAGNOSIS >

1. Check the continuity between CMP sensor harness connector and ECM harness connector.

| DTC   | CMP sensor |           |          | ECM       |          | Continuity |
|-------|------------|-----------|----------|-----------|----------|------------|
|       | Bank       | Connector | Terminal | Connector | Terminal |            |
| P0340 | 1          | F84       | 3        | F111      | 95       | Existed    |
| P0345 | 2          | F83       | 3        |           | 73       |            |

2. Also check harness for short to ground and short to power.

Is the inspection result normal?

YES >> GO TO 10.

NO >> Repair open circuit, short to ground or short to power in harness or connectors.

## 10. CHECK CAMSHAFT POSITION SENSOR

Refer to [EC-1831, "Component Inspection \(Camshaft Position Sensor\)"](#).

Is the inspection result normal?

YES >> GO TO 11.

NO >> Replace malfunctioning camshaft position sensor.

## 11. CHECK CAMSHAFT SPROCKET (SIGNAL PLATE)

Check the following.

- Accumulation of debris to the signal plate of camshaft sprocket (INT)
- Chipping signal plate of camshaft sprocket (INT)

Is the inspection result normal?

YES >> GO TO 12.

NO >> Remove debris and clean the signal plate of camshaft sprocket (INT).

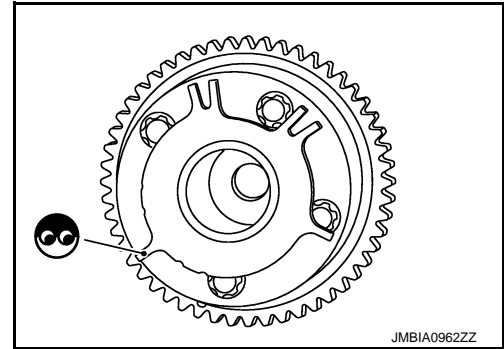

JMBIA0962ZZ

## 12. CHECK INTERMITTENT INCIDENT

Refer to [GI-44, "Intermittent Incident"](#).

>> INSPECTION END

## Component Inspection (Camshaft Position Sensor)

INFOID:000000007758336

### 1. CHECK CAMSHAFT POSITION SENSOR-I

1. Turn ignition switch OFF.
2. Loosen the fixing bolt of the sensor.
3. Disconnect camshaft position sensor harness connector.
4. Remove the sensor.
5. Visually check the sensor for chipping.

Is the inspection result normal?

YES >> GO TO 2.

NO >> Replace malfunctioning camshaft position sensor.

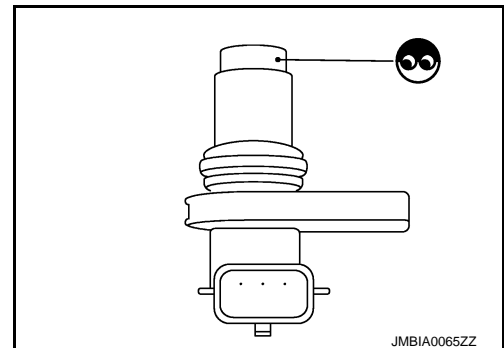

JMBIA0065ZZ

### 2. CHECK CAMSHAFT POSITION SENSOR-II

Check resistance camshaft position sensor terminals as per the following.

# P0340, P0345 CMP SENSOR

< DTC/CIRCUIT DIAGNOSIS >

[VK56VD FOR MEXICO]

| Terminals (Polarity) | Resistance                                     |
|----------------------|--|
| 1 (+) - 2 (-)        | Except 0 or $\infty$ $\Omega$ [at 25°C (77°F)] |
| 1 (+) - 3 (-)        |  |
| 2 (+) - 3 (-)        |  |

Is the inspection result normal?

YES >> INSPECTION END

NO >> Replace malfunctioning camshaft position sensor.



# P0420, P0430 THREE WAY CATALYST FUNCTION

< DTC/CIRCUIT DIAGNOSIS >

[VK56VD FOR MEXICO]

## P0420, P0430 THREE WAY CATALYST FUNCTION

### DTC Logic

INFOID:000000007758337

#### DTC DETECTION LOGIC

The ECM monitors the switching frequency ratio of air fuel ratio (A/F) sensor 1 and heated oxygen sensor 2.

A three way catalyst (manifold) with high oxygen storage capacity will indicate a low switching frequency of heated oxygen sensor 2. As oxygen storage capacity decreases, the heated oxygen sensor 2 switching frequency will increase.

When the frequency ratio of A/F sensor 1 and heated oxygen sensor 2 approaches a specified limit value, the three way catalyst (manifold) malfunction is diagnosed.

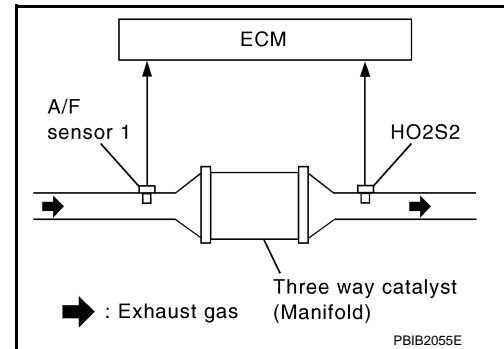

| DTC No. | Trouble diagnosis name (Trouble diagnosis content)                       | DTC detecting condition   | Possible cause  |
|---------|--|---|---|
| P0420   | TW CATALYST SYS-B1 [Catalyst system efficiency below threshold (bank 1)] | <ul style="list-style-type: none"> <li>Three way catalyst (manifold) does not operate properly.</li> <li>Three way catalyst (manifold) does not have enough oxygen storage capacity.</li> </ul> | <ul style="list-style-type: none"> <li>Three way catalyst (manifold)</li> <li>Exhaust tube</li> <li>Intake air leakage</li> <li>Fuel injector</li> <li>Fuel injector leakage</li> <li>Spark plug</li> <li>Improper ignition timing</li> </ul> |
| P0430   | TW CATALYST SYS-B2 [Catalyst system efficiency below threshold (bank 2)] |   |   |

#### DTC CONFIRMATION PROCEDURE

##### 1. INSPECTION START

If DTC Confirmation Procedure has been previously conducted, always perform the following procedure before conducting the next test.

- Turn ignition switch OFF and wait at least 10 seconds.
- Turn ignition switch ON.
- Turn ignition switch OFF and wait at least 10 seconds.

Will CONSULT be used?

- YES >> GO TO 2.  
NO >> GO TO 6.

##### 2. PERFORM DTC CONFIRMATION PROCEDURE-I

WITH CONSULT

##### TESTING CONDITION:

**Do not maintain engine speed for more than the specified minutes below.**

- Start engine and warm it up to the normal operating temperature.
- Turn ignition switch OFF and wait at least 10 seconds.
- Turn ignition switch ON.
- Turn ignition switch OFF and wait at least 10 seconds.
- Start engine and keep the engine speed between 3,500 and 4,000 rpm for at least 1 minute under no load.
- Let engine idle for 1 minute.
- Select "DATA MONITOR" mode with CONSULT.
- Check that "COOLAN TEMP/S" indicates more than 70°C (158°F).  
If not, warm up engine and go to next step when "COOLAN TEMP/S" indication reaches to 70°C (158°F).
- Open engine hood.
- Select "DTC & SRT CONFIRMATION" then "SRT WORK SUPPORT" mode with CONSULT.
- Rev engine between 2,000 and 3,000 rpm and hold it for 3 consecutive minutes then release the accelerator pedal completely.
- Check the indication of "CATALYST".

Which is displayed on CONSULT screen?

# P0420, P0430 THREE WAY CATALYST FUNCTION

< DTC/CIRCUIT DIAGNOSIS >

[VK56VD FOR MEXICO]

CMPLT >> GO TO 5.  
INCMP >> GO TO 3.

## 3. PERFORM DTC CONFIRMATION PROCEDURE-II

1. Wait 5 seconds at idle.
2. Rev engine between 2,000 and 3,000 rpm and maintain it until "INCMP" of "CATALYST" changes to "CMPLT" (It will take approximately 5 minutes).

Does the indication change to "CMPLT"?

YES >> GO TO 5.  
NO >> GO TO 4.

## 4. PERFORM DTC CONFIRMATION PROCEDURE AGAIN

1. Stop engine and cool it down to less than 70°C (158°F).
2. Perform DTC CONFIRMATION PROCEDURE again.

>> GO TO 2.

## 5. PERFORM DTC CONFIRMATION PROCEDURE-III

Check 1st trip DTC.

Is 1st trip DTC detected?

YES >> Proceed to [EC-1835, "Diagnosis Procedure"](#).  
NO >> INSPECTION END

## 6. PERFORM COMPONENT FUNCTION CHECK

 WITH GST

Perform component function check. Refer to [EC-1834, "Component Function Check"](#).

### NOTE:

Use component function check to check the overall function of the three way catalyst (manifold). During this check, a 1st trip DTC might not be confirmed.

Is the inspection result normal?

YES >> INSPECTION END  
NO >> Proceed to [EC-1835, "Diagnosis Procedure"](#)

## Component Function Check

INFOID:000000007758338

## 1. PERFORM COMPONENT FUNCTION CHECK

 With GST

1. Start engine and warm it up to the normal operating temperature.
2. Turn ignition switch OFF and wait at least 10 seconds.
3. Start engine and keep the engine speed between 3,500 and 4,000 rpm for at least 1 minute under no load.
4. Let engine idle for 1 minute.
5. Open engine hood.
6. Check the voltage between ECM harness connector terminals under the following conditions.

| DTC   | ECM       |                           |          | Condition  | Voltage  |
|-------|-----------|---------------------------|----------|--|--|
|       | Connector | +                         | -        |  |  |
|       |           | Terminal                  | Terminal |  |  |
| P0420 | F110      | 96<br>[HO2S2<br>(bank 1)] | 100      | Keeping engine speed at 2,500 rpm constant under no load | The voltage fluctuation cycle takes more than 5 seconds.<br>• 1 cycle: 0.6 - 1.0 → 0 - 0.3 → 0.6 - 1.0 |
| P0430 |           | 87<br>[HO2S2<br>(bank 2)] |          |  |  |

Is the inspection result normal?

YES >> INSPECTION END  
NO >> Proceed to [EC-1835, "Diagnosis Procedure"](#).

# P0420, P0430 THREE WAY CATALYST FUNCTION

< DTC/CIRCUIT DIAGNOSIS >

[VK56VD FOR MEXICO]

INFOID:000000007758339

## Diagnosis Procedure

### 1. CHECK EXHAUST SYSTEM

Visually check exhaust tubes and muffler for dents.

Is the inspection result normal?

YES >> GO TO 2.

NO >> Repair or replace malfunctioning part.

### 2. CHECK EXHAUST GAS LEAKAGE

1. Start engine and run it at idle.

2. Listen for an exhaust gas leakage before the three way catalyst (manifold).

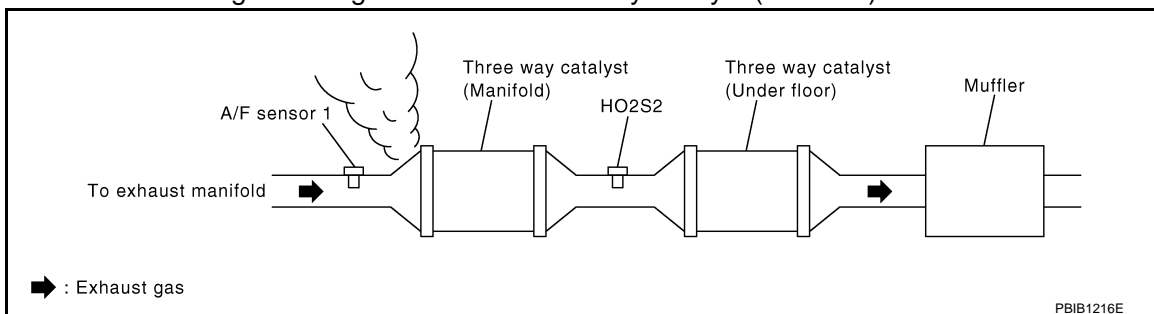

Is exhaust gas leakage detected?

YES >> Repair or replace malfunctioning part.

NO >> GO TO 3.

### 3. CHECK INTAKE AIR LEAKAGE

Listen for an intake air leakage after the mass air flow sensor.

Is intake air leakage detected?

YES >> Repair or replace malfunctioning part.

NO >> GO TO 4.

### 4. CHECK IDLE SPEED AND IGNITION TIMING

Check idle speed and ignition timing.

For procedure, refer to [EC-1679, "Work Procedure"](#).

For specification, refer to [EC-2016, "Idle Speed"](#) and [EC-2016, "Ignition Timing"](#).

Is the inspection result normal?

YES >> GO TO 5.

NO >> Follow the [EC-1679, "Work Procedure"](#).

### 5. CHECK FUEL INJECTORS

Refer to [EC-1976, "Component Function Check"](#).

Is the inspection result normal?

YES >> GO TO 6.

NO >> Perform [EC-1976, "Diagnosis Procedure"](#).

### 6. CHECK FUNCTION OF IGNITION COIL-I

#### CAUTION:

**Perform the following procedure in a place with no combustible objects and good ventilation.**

1. Turn ignition switch OFF.
2. Remove fuel pump fuse in IPDM E/R to release fuel pressure.

#### NOTE:

- For the fuse number, refer to [EC-1667, "Wiring Diagram"](#).
- For the fuse arrangement, refer to [PG-40, "Fuse, Connector and Terminal Arrangement"](#).
- Do not use CONSULT to release fuel pressure, or fuel pressure applies again during the following procedure.

3. Start engine.
4. After engine stalls, crank it 2 or 3 times to release all fuel pressure.
5. Turn ignition switch OFF.

## P0420, P0430 THREE WAY CATALYST FUNCTION

< DTC/CIRCUIT DIAGNOSIS >

[VK56VD FOR MEXICO]

6. Remove all ignition coil harness connectors to avoid the electrical discharge from the ignition coils.
7. Remove ignition coil and spark plug of the cylinder to be checked.
8. Crank engine for 5 seconds or more to remove combustion gas in the cylinder.
9. Connect spark plug and harness connector to ignition coil.
10. Fix ignition coil using a rope etc. with gap of 13 - 17 mm (0.52 - 0.66 in) between the edge of the spark plug and grounded metal portion as shown in the figure.
11. Crank engine for approximately 3 seconds, and check whether spark is generated between the spark plug and the grounded metal portion.

**Spark should be generated.**

### CAUTION:

- Never place the spark plug and the ignition coil within 50 cm (19.7 in) each other. Be careful not to get an electrical shock while checking, because the electrical discharge voltage becomes 20 kV or more.
- It might damage the ignition coil if the gap of more than 17 mm (0.66 in) is made.

### NOTE:

When the gap is less than 13 mm (0.52 in), a spark might be generated even if the coil is malfunctioning.

Is the inspection result normal?

- YES >> GO TO 10.  
NO >> GO TO 7.

## 7. CHECK FUNCTION OF IGNITION COIL-II

1. Turn ignition switch OFF.
2. Disconnect spark plug and connect a non-malfunctioning spark plug.
3. Crank engine for approximately 3 seconds, and recheck whether spark is generated between the spark plug and the grounded metal portion.

**Spark should be generated.**

Is the inspection result normal?

- YES >> GO TO 8.  
NO >> Check ignition coil, power transistor and their circuits. Refer to [EC-1984. "Diagnosis Procedure"](#).

## 8. CHECK SPARK PLUG

Check the initial spark plug for fouling, etc.

Is the inspection result normal?

- YES >> Replace spark plug(s) with standard type one(s). For spark plug type, refer to [EM-301. "Spark Plug"](#).  
NO >> Repair or clean spark plug. Then GO TO 9.

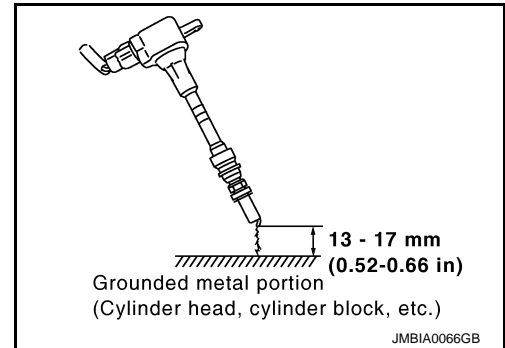

## 9. CHECK FUNCTION OF IGNITION COIL-III

1. Reconnect the initial spark plugs.
2. Crank engine for approximately 3 seconds, and recheck whether spark is generated between the spark plug and the grounded portion.

**Spark should be generated.**

Is the inspection result normal?

- YES >> INSPECTION END

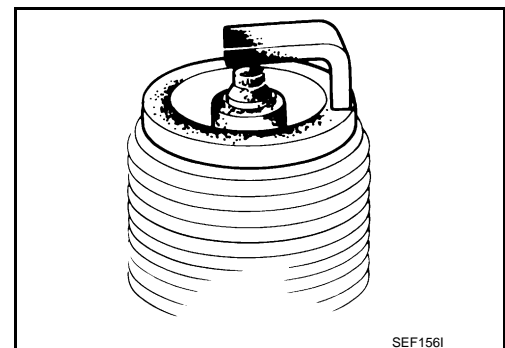

## P0420, P0430 THREE WAY CATALYST FUNCTION

< DTC/CIRCUIT DIAGNOSIS >

[VK56VD FOR MEXICO]

NO >> Replace spark plug(s) with standard type one(s). For spark plug type, refer to [EM-301. "Spark Plug"](#).

A

### 10.CHECK FUEL INJECTOR

1. Turn ignition switch OFF.
2. Remove fuel injector assembly.  
Refer to [EM-197. "Removal and Installation"](#).  
Keep fuel hose and all fuel injectors connected to fuel tube.
3. Disconnect all ignition coil harness connectors.
4. Reconnect all fuel injector harness connectors disconnected.
5. Turn ignition switch ON.
6. Check that fuel does not drip from fuel injector.

EC

C

D

Does fuel drip from fuel injector?

YES >> Replace the fuel injector(s) from which fuel is dripping.  
NO >> GO TO 11.

E

### 11.CHECK INTERMITTENT INCIDENT

Refer to [GI-44. "Intermittent Incident"](#).

Is the inspection result normal?

F

YES >> Replace three way catalyst assembly.  
NO >> Repair or replace harness or connector.

G

H

I

J

K

L

M

N

O

P

# P0444 EVAP CANISTER PURGE VOLUME CONTROL SOLENOID VALVE

< DTC/CIRCUIT DIAGNOSIS >

[VK56VD FOR MEXICO]

## P0444 EVAP CANISTER PURGE VOLUME CONTROL SOLENOID VALVE

### DTC Logic

INFOID:000000007758346

### DTC DETECTION LOGIC

| DTC No. | Trouble diagnosis name<br>(Trouble diagnosis content)                                  | DTC detecting condition  | Possible cause   |
|---------|--|--|--|
| P0444   | PURG VOLUME CONT/V<br>(EVAP canister purge volume control solenoid valve circuit open) | An excessively low voltage signal is sent to ECM through the valve | <ul style="list-style-type: none"><li>• Harness or connectors<br/>(The solenoid valve circuit is open or shorted.)</li><li>• EVAP canister purge volume control solenoid valve</li></ul> |

### DTC CONFIRMATION PROCEDURE

#### 1. PRECONDITIONING

1. Turn ignition switch OFF and wait at least 10 seconds.
2. Turn ignition switch ON.
3. Turn ignition switch OFF and wait at least 10 seconds.

#### TESTING CONDITION:

Before performing the following procedure, confirm battery voltage is 11 V or more at idle.

>> GO TO 2.

#### 2. PERFORM DTC CONFIRMATION PROCEDURE

1. Start engine and let it idle for at least 13 seconds.
2. Check 1st trip DTC.

Is 1st trip DTC detected?

YES >> Proceed to [EC-1838, "Diagnosis Procedure"](#).

NO >> INSPECTION END

### Diagnosis Procedure

INFOID:000000007758347

#### 1. CHECK EVAP CANISTER PURGE VOLUME CONTROL SOLENOID VALVE POWER SUPPLY CIRCUIT

1. Turn ignition switch OFF.
2. Disconnect EVAP canister purge volume control solenoid valve harness connector.
3. Turn ignition switch ON.
4. Check the voltage between EVAP canister purge volume control solenoid valve harness connector and ground.

| EVAP canister purge volume control solenoid valve |          | Ground | Voltage         |
|---|----------|--------|-----------------|
| Connector   | Terminal |        |                 |
| F10   | 1        | Ground | Battery voltage |

Is the inspection result normal?

YES >> GO TO 3.

NO >> GO TO 2.

#### 2. DETECT MALFUNCTIONING PART

Check the following.

- Loose or poor connection for each connector and harness
- Harness for open or short between EVAP canister purge volume control solenoid valve and IPDM E/R
- Harness for open or short between EVAP canister purge volume control solenoid valve and ECM

>> Repair open circuit, short to ground or short to power in harness or connectors.

#### 3. CHECK EVAP CANISTER PURGE VOLUME CONTROL SOLENOID VALVE OUTPUT SIGNAL CIRCUIT

# P0444 EVAP CANISTER PURGE VOLUME CONTROL SOLENOID VALVE

< DTC/CIRCUIT DIAGNOSIS >

[VK56VD FOR MEXICO]

FOR OPEN AND SHORT

1. Turn ignition switch OFF.
2. Disconnect ECM harness connector.
3. Check the continuity between EVAP canister purge volume control solenoid valve harness connector and ECM harness connector.

| EVAP canister purge volume control solenoid valve |          | ECM       |          | Continuity |
|---|----------|-----------|----------|------------|
| Connector   | Terminal | Connector | Terminal |            |
| F10   | 2        | F111      | 64       | Existed    |

4. Also check harness for short to ground and short to power.

Is the inspection result normal?

YES-1 >> With CONSULT: GO TO 4.

YES-2 >> Without CONSULT: GO TO 5.

NO >> Repair open circuit, short to ground or short to power in harness or connectors.

## 4.CHECK EVAP CANISTER PURGE VOLUME CONTROL SOLENOID VALVE OPERATION

Ⓜ WITH CONSULT

1. Reconnect all harness connectors disconnected.
2. Start engine.
3. Perform "PURG VOL CONT/V" in "ACTIVE TEST" mode with CONSULT. Check that engine speed varies according to the valve opening.

Does engine speed vary according to the valve opening?

YES >> GO TO 6.

NO >> GO TO 5.

## 5.CHECK EVAP CANISTER PURGE VOLUME CONTROL SOLENOID VALVE

Refer to [EC-1839. "Component Inspection \(EVAP Canister Purge Volume Control Solenoid Valve\)".](#)

Is the inspection result normal?

YES >> GO TO 6.

NO >> Replace EVAP canister purge volume control solenoid valve. Refer to [EM-190. "Exploded View".](#)

## 6.CHECK INTERMITTENT INCIDENT

Refer to [GI-44. "Intermittent Incident".](#)

>> INSPECTION END

## Component Inspection (EVAP Canister Purge Volume Control Solenoid Valve)

INFOID:000000007758348

## 1.CHECK EVAP CANISTER PURGE VOLUME CONTROL SOLENOID VALVE

Ⓜ WITH CONSULT

1. Turn ignition switch OFF.
2. Reconnect all harness connectors disconnected.
3. Disconnect EVAP purge hoses connected to EVAP canister purge volume control solenoid valve.
4. Turn ignition switch ON.
5. Select "PURG VOL CONT/V" in "ACTIVE TEST" mode with CONSULT.

# P0444 EVAP CANISTER PURGE VOLUME CONTROL SOLENOID VALVE

[VK56VD FOR MEXICO]

## < DTC/CIRCUIT DIAGNOSIS >

6. Touch “Qd” and “Qu” on CONSULT screen to adjust “PURG VOL C/V” opening and check air passage continuity of EVAP canister purge volume control solenoid valve under the following conditions.

| Condition<br>(PURG VOL C/V value) | Air passage continuity<br>between (A) and (B) |
|-----------------------------------|---|
| 100%                              | Existed                                       |
| 0%                                | Not existed                                   |

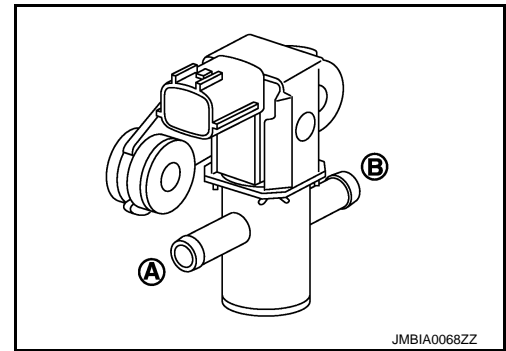

### ⊗ WITHOUT CONSULT

1. Turn ignition switch OFF.
2. Disconnect EVAP canister purge volume control solenoid valve harness connector.
3. Disconnect EVAP purge hoses connected to EVAP canister purge volume control solenoid valve.
4. Check air passage continuity of EVAP canister purge volume control solenoid valve under the following conditions.

| Condition   | Air passage continuity<br>between (A) and (B) |
|---|---|
| 12 V direct current supply between<br>terminals 1 and 2 | Existed                                       |
| No supply   | Not existed                                   |

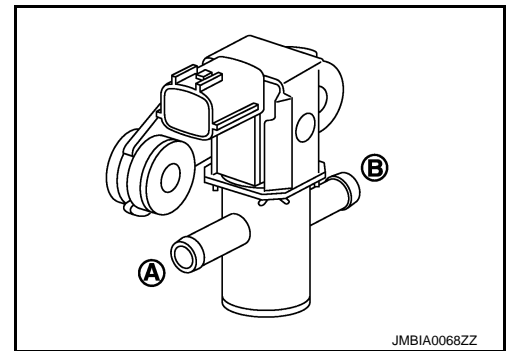

### Is the inspection result normal?

YES >> INSPECTION END

NO >> Replace EVAP canister purge volume control solenoid valve



P0500 VSS

Description

INFOID:000000007758374

The vehicle speed signal is sent to the “combination meter” from the “ABS actuator and electric unit (control unit)” by CAN communication line. The “combination meter” then sends a signal to the ECM by CAN communication line.

DTC Logic

INFOID:000000007758375

DTC DETECTION LOGIC

NOTE:

- If DTC P0500 is displayed with DTC UXXXX, first perform the trouble diagnosis for DTC UXXXX.
- If DTC P0500 is displayed with DTC P0607, first perform the trouble diagnosis for DTC P0607. Refer to [EC-1860, "DTC Logic"](#).

| DTC No. | Trouble diagnosis name<br>(Trouble diagnosis content) | DTC detecting condition  | Possible cause   |
|---------|---|--|--|
| P0500   | VEH SPEED SEN/CIRC<br>(Vehicle speed sensor)          | The vehicle speed signal sent to ECM is almost 0 km/h (0 MPH) even when vehicle is being driven. | <ul style="list-style-type: none"> <li>• Harness or connectors<br/>(The CAN communication line is open or shorted)</li> <li>• Harness or connectors<br/>(The vehicle speed signal circuit is open or shorted)</li> <li>• Wheel sensor</li> <li>• Combination meter</li> <li>• ABS actuator and electric unit (control unit)</li> </ul> |

DTC CONFIRMATION PROCEDURE

1.INSPECTION START

If DTC Confirmation Procedure has been previously conducted, always perform the following procedure before conducting the next test.

1. Turn ignition switch OFF and wait at least 10 seconds.
2. Turn ignition switch ON.
3. Turn ignition switch OFF and wait at least 10 seconds.

Will CONSULT be used?

- YES >> GO TO 2.  
NO >> GO TO 4.

2.CHECK VEHICLE SPEED SIGNAL

NOTE:

This procedure may be conducted with the drive wheels lifted in the shop or by driving the vehicle. If a road test is expected to be easier, it is unnecessary to lift the vehicle.

Ⓜ WITH CONSULT

1. Start engine (VDC switch OFF).
2. Read “VHCL SPEED SE” in “DATA MONITOR” mode with CONSULT.  
The vehicle speed on CONSULT should exceed 10 km/h (6 MPH) when rotating wheels with suitable gear position.

Is the inspection result normal?

- YES >> GO TO 3.  
NO >> Proceed to [EC-1842, "Diagnosis Procedure"](#).

3.PERFORM DTC CONFIRMATION PROCEDURE

1. Select “DATA MONITOR” mode with CONSULT.
2. Warm engine up to normal operating temperature.
3. Maintain the following conditions for at least 50 consecutive seconds.

**CAUTION:**

Always drive vehicle at a safe speed.

## &lt; DTC/CIRCUIT DIAGNOSIS &gt;

|                |                        |
|----------------|------------------------|
| ENG SPEED      | More than 1,500 rpm    |
| COOLAN TEMP/S  | More than 70°C (158°F) |
| B/FUEL SCHDL   | 5.5 - 31.8 msec        |
| Selector lever | Except P or N position |
| PW/ST SIGNAL   | OFF                    |

4. Check 1st trip DTC.

Is 1st trip DTC detected?

- YES >> Proceed to [EC-1842, "Diagnosis Procedure"](#).  
 NO >> INSPECTION END

#### 4.PERFORM COMPONENT FUNCTION CHECK

 WITH GST

Perform Component Function Check. Refer to [EC-1842, "Component Function Check"](#).

Use Component Function Check to check the overall function of the vehicle speed signal circuit. During this check, a 1st trip DTC might not be confirmed.

Is the inspection result normal?

- YES >> INSPECTION END  
 NO >> Proceed to [EC-1842, "Diagnosis Procedure"](#).

### Component Function Check

INFOID:000000007758376

#### 1.PERFORM COMPONENT FUNCTION CHECK

 With GST

- Lift up drive wheels.
- Start engine.
- Read vehicle speed signal in Service \$01 with GST.  
The vehicle speed signal on GST should be able to exceed 10 km/h (6 MPH) when rotating wheels with suitable gear position.

Is the inspection result normal?

- YES >> INSPECTION END  
 NO >> Proceed to [EC-1842, "Diagnosis Procedure"](#).

### Diagnosis Procedure

INFOID:000000007758377

#### 1.CHECK DTC WITH "ABS ACTUATOR AND ELECTRIC UNIT (CONTROL UNIT)"

Refer to [BRC-40, "CONSULT Function"](#).

Is the inspection result normal?

- YES >> GO TO 2.  
 NO >> Repair or replace malfunctioning part.

#### 2.CHECK DTC WITH "COMBINATION METER"

Refer to [MWI-31, "CONSULT Function"](#).

>> INSPECTION END

P0506 ISC SYSTEM

Description

INFOID:000000007758378

The ECM controls the engine idle speed to a specified level through the fine adjustment of the air, which is let into the intake manifold, by operating the electric throttle control actuator. The operating of the throttle valve is varied to allow for optimum control of the engine idling speed. The crankshaft position sensor detects the actual engine speed and sends a signal to the ECM.

The ECM controls the electric throttle control actuator so that the engine speed coincides with the target value memorized in the ECM. The target engine speed is the lowest speed at which the engine can operate steadily. The optimum value stored in the ECM is determined by taking into consideration various engine conditions, such as during warming up, deceleration and engine load (air conditioner, power steering and cooling fan operation, etc.).

DTC Logic

INFOID:000000007758379

DTC DETECTION LOGIC

**NOTE:**

**If DTC P0506 is displayed with other DTC, first perform the trouble diagnosis for the other DTC.**

| DTC No. | Trouble diagnosis name<br>(Trouble diagnosis content)                | DTC detecting condition   | Possible cause   |
|---------|--|---|--|
| P0506   | ISC SYSTEM<br>(Idle speed control system<br>RPM lower than expected) | The idle speed is less than the target idle speed by 100 rpm or more. | <ul style="list-style-type: none"> <li>• Electric throttle control actuator</li> <li>• Intake air leakage</li> </ul> |

DTC CONFIRMATION PROCEDURE

**1. PRECONDITIONING**

1. Turn ignition switch OFF and wait at least 10 seconds.
2. Turn ignition switch ON.
3. Turn ignition switch OFF and wait at least 10 seconds.

**If the target idle speed is out of the specified value, perform [EC-1687, "Work Procedure"](#), before conducting DTC Confirmation Procedure.**

**TESTING CONDITION:**

- Before performing the following procedure, confirm that battery voltage is 11 V or more at idle.
- Always perform the test at a temperature above -10°C (14°F).

>> GO TO 2.

**2. PERFORM DTC CONFIRMATION PROCEDURE**

1. Start engine and warm it up to normal operating temperature.
2. Turn ignition switch OFF and wait at least 10 seconds.
3. Turn ignition switch ON.
4. Turn ignition switch OFF and wait at least 10 seconds.
5. Restart engine and run it for at least 1 minute at idle speed.
6. Check 1st trip DTC.

Is 1st trip DTC detected?

YES >> Proceed to [EC-1843, "Diagnosis Procedure"](#).

NO >> INSPECTION END

Diagnosis Procedure

INFOID:000000007758380

**1. CHECK INTAKE AIR LEAKAGE**

1. Start engine and let it idle.
2. Listen for an intake air leakage after the mass air flow sensor.

Is intake air leakage detected?

YES >> Discover air leakage location and repair.

## P0506 ISC SYSTEM

< DTC/CIRCUIT DIAGNOSIS >

[VK56VD FOR MEXICO]

---

NO >> GO TO 2.

### 2. REPLACE ECM

---

1. Stop engine.
2. Replace ECM.
3. Perform additional service when replacing ECM. Refer to [EC-1683, "Work Procedure"](#).

>> INSPECTION END

P0507 ISC SYSTEM

Description

INFOID:000000007758381

The ECM controls the engine idle speed to a specified level through the fine adjustment of the air, which is let into the intake manifold, by operating the electric throttle control actuator. The operating of the throttle valve is varied to allow for optimum control of the engine idling speed. The crankshaft position sensor detects the actual engine speed and sends a signal to the ECM.

The ECM controls the electric throttle control actuator so that the engine speed coincides with the target value memorized in the ECM. The target engine speed is the lowest speed at which the engine can operate steadily. The optimum value stored in the ECM is determined by taking into consideration various engine conditions, such as during warming up, deceleration and engine load (air conditioner, power steering and cooling fan operation, etc.).

DTC Logic

INFOID:000000007758382

DTC DETECTION LOGIC

NOTE:

If DTC P0507 is displayed with other DTC, first perform the trouble diagnosis for the other DTC.

| DTC No. | Trouble diagnosis name<br>(Trouble diagnosis content)                 | DTC detecting condition   | Possible cause   |
|---------|---|---|--|
| P0507   | ISC SYSTEM<br>(Idle speed control system<br>RPM higher than expected) | The idle speed is more than the target idle speed by 200 rpm or more. | <ul style="list-style-type: none"> <li>• Electric throttle control actuator</li> <li>• Intake air leakage</li> <li>• PCV system</li> </ul> |

DTC CONFIRMATION PROCEDURE

1. PRECONDITIONING

1. Turn ignition switch OFF and wait at least 10 seconds.
2. Turn ignition switch ON.
3. Turn ignition switch OFF and wait at least 10 seconds.

If the target idle speed is out of the specified value, perform [EC-1687. "Work Procedure"](#), before conducting DTC Confirmation Procedure.

TESTING CONDITION:

- Before performing the following procedure, confirm that battery voltage is 11 V or more at idle.
- Always perform the test at a temperature above -10°C (14°F).

>> GO TO 2.

2. PERFORM DTC CONFIRMATION PROCEDURE

1. Start engine and warm it up to normal operating temperature.
2. Turn ignition switch OFF and wait at least 10 seconds.
3. Turn ignition switch ON.
4. Turn ignition switch OFF and wait at least 10 seconds.
5. Start engine and run it for at least 1 minute at idle speed.
6. Check 1st trip DTC.

Is 1st trip DTC detected?

- YES >> Proceed to [EC-1845. "Diagnosis Procedure"](#).  
 NO >> INSPECTION END

Diagnosis Procedure

INFOID:000000007758383

1. CHECK PCV HOSE CONNECTION

Confirm that PCV hose is connected correctly.

Is the inspection result normal?

- YES >> GO TO 2.  
 NO >> Repair or replace malfunctioning part.

< DTC/CIRCUIT DIAGNOSIS >

---

**2.**CHECK INTAKE AIR LEAKAGE

---

1. Start engine and let it idle.
2. Listen for an intake air leakage after the mass air flow sensor.

Is intake air leakage detected?

YES >> Discover air leakage location and repair.

NO >> GO TO 3.

**3.**REPLACE ECM

---

1. Stop engine.
2. Replace ECM.
3. Perform additional service when replacing ECM. Refer to [EC-1683, "Work Procedure"](#).

>> INSPECTION END

P0520 EOP SENSOR

DTC Logic

INFOID:000000007758387

DTC DETECTION LOGIC

| DTC No. | Trouble diagnosis<br>(Trouble diagnosis content) | Detecting condition   | Possible cause  |
|---------|--|---|---|
| P0520   | EOP sensor circuit                               | Signal voltage from the EOP sensor remains at more than 4.9 V / less than 0.26 V for 5 seconds or more. | <ul style="list-style-type: none"> <li>• Harness or connectors (EOP sensor circuit is open or shorted.) (Power steering pressure sensor circuit is open or shorted.) (Low fuel pressure sensor circuit is open or shorted.) (FRP sensor circuit is open or shorted.)</li> <li>• Engine oil level abnormality</li> <li>• EOP sensor</li> <li>• Power steering pressure sensor</li> <li>• Low fuel pressure sensor</li> <li>• FRP sensor</li> </ul> |

DTC CONFIRMATION PROCEDURE

1. PRECONDITIONING

If DTC Confirmation Procedure has been previously conducted, always perform the following procedure before conducting the next test.

1. Turn ignition switch OFF and wait at least 10 seconds.
2. Turn ignition switch ON.
3. Turn ignition switch OFF and wait at least 10 seconds.

>> GO TO 2.

2. PERFORM DTC CONFIRMATION PROCEDURE

1. Turn ignition switch ON and wait at least 5 seconds.
2. Check 1st trip DTC.

Is 1st trip DTC detected?

- YES >> Proceed to [EC-1847, "Diagnosis Procedure"](#).
- NO >> INSPECTION END

Diagnosis Procedure

INFOID:000000007758388

1. CHECK ENGINE OIL

1. Turn ignition switch OFF.
2. Check engine oil level and pressure. Refer to [LU-23, "Inspection"](#).

Is inspection result normal?

- YES >> GO TO 2.
- NO >> Repair or replace error-detected parts.

2. CHECK EOP SENSOR POWER SUPPLY-I

1. Disconnect EOP sensor connector.
2. Turn ignition switch ON.
3. Check the voltage between EOP sensor harness connector terminals.

# P0520 EOP SENSOR

< DTC/CIRCUIT DIAGNOSIS >

[VK56VD FOR MEXICO]

| EOP sensor |   |          | Voltage<br>(Approx.) |
|------------|---|----------|----------------------|
| Connector  | + | -        |                      |
|            |   | terminal |                      |
| F32        | 3 | 1        | 5 V                  |

Inspection result normal?

- YES >> GO TO 7.  
NO >> GO TO 3.

## 3.CHECK EOP SENSOR POWER SUPPLY-II

Check the voltage between EOP sensor harness connector and the ground.

| +          |          | -      | Voltage<br>(Approx.) |
|------------|----------|--------|----------------------|
| EOP sensor |          |        |                      |
| Connector  | Terminal |        |                      |
| F32        | 3        | Ground | 5 V                  |

Is inspection result normal?

- YES >> GO TO 5.  
NO >> GO TO 4.

## 4.CHECK SENSOR POWER SUPPLY CIRCUIT

- Turn ignition switch OFF.
- Disconnect ECM harness connector.
- Check harness connector for short to power and short to ground, between the following terminals.

| ECM       |          | Sensor                         |           |          |
|-----------|----------|--------------------------------|-----------|----------|
| Connector | Terminal | Name                           | Connector | Terminal |
| F110      | 27       | Power steering pressure sensor | F35       | 3        |
|           |          | Low fuel pressure sensor       | F39       | 3        |
|           | 28       | FRP sensor                     | F6        | 1        |
|           |          | Engine oil pressure sensor     | F32       | 3        |

Is inspection result normal?

- YES >> Perform the trouble diagnosis for power supply circuit. Refer to [EC-1707. "Diagnosis Procedure"](#).  
NO >> Repair or replace error-detected parts.

## 5.CHECK EOP SENSOR GROUND CIRCUIT

- Turn ignition switch OFF.
- Disconnect ECM harness connector.
- Check the continuity between EOP sensor harness connector and ECM harness connector.

| +          |          | -         |          | Continuity |
|------------|----------|-----------|----------|------------|
| EOP sensor |          | ECM       |          |            |
| Connector  | Terminal | Connector | Terminal |            |
| F32        | 1        | F110      | 40       | Existed    |

Is inspection result normal?

- YES >> GO TO 6.  
NO >> Repair or replace error-detected parts.

## 6.CHECK ECM GROUND CIRCUIT

Check the continuity between ECM harness connector and ground.



# P0520 EOP SENSOR

< DTC/CIRCUIT DIAGNOSIS >

[VK56VD FOR MEXICO]

| ECM       |          | Ground | Continuity |
|-----------|----------|--------|------------|
| Connector | Terminal |        |            |
| F110      | 10       | Ground | Existed    |
| M160      | 114      |        |            |
|           | 115      |        |            |
|           | 174      |        |            |
|           | 175      |        |            |

Is inspection result normal?

- YES >> Check intermittent incident. Refer to [GI-44, "Intermittent Incident"](#).  
 NO >> Repair or replace error-detected parts.

## 7. CHECK EOP SENSOR SIGNAL CIRCUIT

- Turn ignition switch OFF.
- Disconnect ECM harness connector.
- Check the continuity between EOP sensor harness connector and ECM harness connector.

| +          |          | -         |          | Continuity |
|------------|----------|-----------|----------|------------|
| EOP sensor |          | ECM       |          |            |
| Connector  | Terminal | Connector | Terminal |            |
| F32        | 2        | F110      | 41       | Existed    |

- Also check harness for short to ground and to power.

Is inspection result normal?

- YES >> GO TO 8.  
 NO >> Repair or replace error-detected parts.

## 8. CHECK EOP SENSOR

Refer to [EC-1849, "Component Inspection \(EOP sensor\)"](#).

Is inspection result normal?

- YES >> Check intermittent incident. Refer to [GI-44, "Intermittent Incident"](#).  
 NO >> Repair or replace error-detected parts.

## Component Inspection (EOP sensor)

INFOID:000000007758389

### 1. CHECK EOP SENSOR

- Turn ignition switch OFF.
- Disconnect EOP sensor harness connector.
- Check resistance between EOP sensor connector terminals.

| +          | - | Condition | Resistance (kΩ) |
|------------|---|-----------|-----------------|
| EOP sensor |   |           |                 |
| Terminal   |   |           |                 |
| 1          | 2 | None      | 4 kΩ – 10 kΩ    |
|            | 3 |           | 2 kΩ – 8 kΩ     |
| 2          | 1 |           | 4 kΩ – 10 kΩ    |
|            | 3 |           | 1 kΩ – 3 kΩ     |
| 3          | 1 |           | 2 kΩ – 8 kΩ     |
|            | 2 |           | 1 kΩ – 3 kΩ     |

Is the inspection result normal?

- YES >> INSPECTION END.  
 NO >> Replace EOP sensor.

# P0524 ENGINE OIL PRESSURE

< DTC/CIRCUIT DIAGNOSIS >

[VK56VD FOR MEXICO]

## P0524 ENGINE OIL PRESSURE

### DTC Logic

INFOID:000000007758390

#### DTC DETECTION LOGIC

##### NOTE:

If DTC P0524 is displayed with DTC P0520, P0075, or P0081, perform trouble diagnosis for DTC P0520, P0075, or P0081 first. Refer to [EC-1731, "DTC Logic"](#).

| DTC No. | Trouble diagnosis name<br>(Trouble diagnosis content) | Detecting condition  | Possible cause   |
|---------|---|--|--|
| P0524   | ENGINE OIL PRESSURE<br>(Engine oil pressure too low)  | Engine oil pressure is low because there is a gap between angle of target and phase-control angle. | <ul style="list-style-type: none"><li>• Engine oil pressure or level too low</li><li>• Crankshaft position sensor</li><li>• Camshaft position sensor</li><li>• Intake valve timing control solenoid valve</li><li>• Accumulation of debris to the signal pick-up portion of the camshaft</li><li>• Timing chain installation</li><li>• Foreign matter caught in the oil groove for intake valve timing control</li></ul> |

#### DTC CONFIRMATION PROCEDURE

##### 1. PRECONDITIONING-I

1. Turn ignition switch OFF and wait at least 10 seconds.
2. Turn ignition switch ON.
3. Turn ignition switch OFF and wait at least 10 seconds.

##### TESTING CONDITION:

Before performing the following procedure, confirm that battery voltage is between 10 V and 16 V at idle.

>> GO TO 2.

##### 2. PRECONDITIONING-II

Check oil level and oil pressure. Refer to [LU-23, "Inspection"](#).

Is the inspection result normal?

YES >> GO TO 3.

NO >> Proceed to [LU-23, "Inspection"](#).

##### 3. PERFORM DTC CONFIRMATION PROCEDURE

###### WITH CONSULT

1. Select "DATA MONITOR" mode with CONSULT.
2. Maintain the following conditions for at least 20 consecutive seconds.

|                         |   |
|-------------------------|---|
| ENG SPEED               | More than 1,700 rpm   |
| COOLAN TEMP/S           | More than 70°C (158°F)  |
| Selector lever          | 1st or 2nd position   |
| Driving location uphill | Driving vehicle uphill<br>(Increased engine load will help maintain the driving conditions required for this test.) |

##### CAUTION:

**Always drive at a safe speed.**

3. Check 1st trip DTC.

###### WITH GST

Follow the procedure "With CONSULT" above.

Is 1st trip DTC detected?

YES >> Proceed to [EC-1851, "Diagnosis Procedure"](#)

# P0524 ENGINE OIL PRESSURE

[VK56VD FOR MEXICO]

< DTC/CIRCUIT DIAGNOSIS >

NO >> INSPECTION END

## Diagnosis Procedure

INFOID:000000007758391

### 1. CHECK OIL PRESSURE WARNING LAMP

1. Start engine.
2. Check oil pressure warning lamp and confirm it is not illuminated.

Is oil pressure warning lamp illuminated?

- YES >> Proceed to [LU-23. "Inspection"](#).  
NO >> GO TO 2.

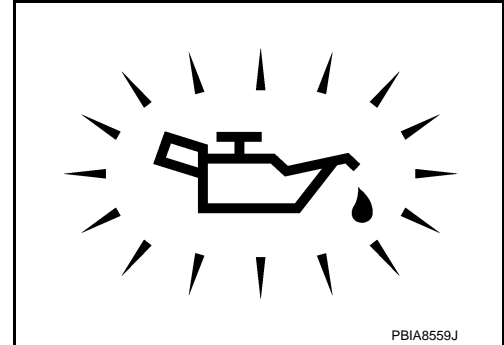

### 2. CHECK INTAKE VALVE TIMING CONTROL SOLENOID VALVE

Refer to [EC-1719. "Component Inspection \(Intake Valve Timing Control Solenoid Valve\)"](#).

Is the inspection result normal?

- YES >> GO TO 3.  
NO >> Replace malfunctioning intake valve timing control solenoid valve.

### 3. CHECK CRANKSHAFT POSITION SENSOR

Refer to [EC-1826. "Component Inspection \(Crankshaft Position Sensor\)"](#).

Is the inspection result normal?

- YES >> GO TO 4.  
NO >> Replace crankshaft position sensor.

### 4. CHECK CAMSHAFT POSITION SENSOR

Refer to [EC-1831. "Component Inspection \(Camshaft Position Sensor\)"](#).

Is the inspection result normal?

- YES >> GO TO 5.  
NO >> Replace malfunctioning camshaft position sensor.

### 5. CHECK CAMSHAFT SPROCKET (SIGNAL PLATE)

Check the following.

- Accumulation of debris to the signal plate of camshaft sprocket (INT)
- Chipping signal plate of camshaft sprocket (INT)

Is the inspection result normal?

- YES >> GO TO 6.  
NO >> Remove debris and clean the signal plate of camshaft sprocket (INT) or replace camshaft sprocket (INT).  
Refer to [EM-247. "Disassembly and Assembly"](#).

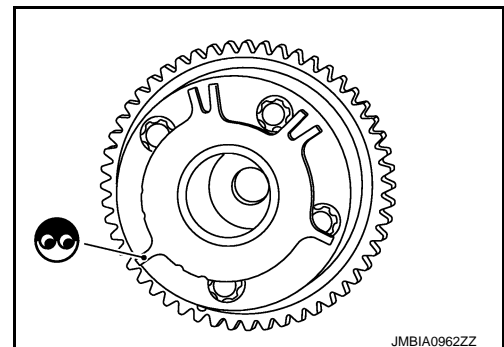

### 6. CHECK TIMING CHAIN INSTALLATION

Check service records for any recent repairs that may cause timing chain misaligned.

Are there any service records that may cause timing chain misaligned?

- YES >> Check timing chain installation. Refer to [EM-244. "Inspection"](#).  
NO >> GO TO 7.

### 7. CHECK LUBRICATION CIRCUIT

Perform "Inspection of Camshaft Sprocket (INT) Oil Groove". Refer to [EM-255. "Inspection"](#).

## P0524 ENGINE OIL PRESSURE

< DTC/CIRCUIT DIAGNOSIS >

[VK56VD FOR MEXICO]

---

Is the inspection result normal?

YES >> GO TO 8.

NO >> Clean lubrication line.

**8.**CHECK INTERMITTENT INCIDENT

---

Refer to [GI-44, "Intermittent Incident"](#).

>> INSPECTION END

# P0550 PSP SENSOR

< DTC/CIRCUIT DIAGNOSIS >

[VK56VD FOR MEXICO]

## P0550 PSP SENSOR

### DTC Logic

INFOID:000000007758392

### DTC DETECTION LOGIC

| DTC No. | Trouble diagnosis name<br>(Trouble diagnosis content)        | DTC detecting condition  | Possible cause  |
|---------|--|--|---|
| P0550   | PW ST P SEN/CIRC<br>(Power steering pressure sensor circuit) | An excessively low or high voltage from the sensor is sent to ECM. | <ul style="list-style-type: none"> <li>• Harness or connectors<br/>(Power steering pressure sensor circuit is open or shorted.)<br/>(EOP sensor circuit is open or shorted.)<br/>(Low fuel pressure sensor circuit is open or shorted.)<br/>(FRP sensor circuit is open or shorted.)</li> <li>• Power steering pressure sensor</li> <li>• EOP sensor</li> <li>• Low fuel pressure sensor</li> <li>• FRP sensor</li> </ul> |

### DTC CONFIRMATION PROCEDURE

#### 1. PRECONDITIONING

If DTC Confirmation Procedure has been previously conducted, always perform the following procedure before conducting the next test.

1. Turn ignition switch OFF and wait at least 10 seconds.
2. Turn ignition switch ON.
3. Turn ignition switch OFF and wait at least 10 seconds.

>> GO TO 2.

#### 2. PERFORM DTC CONFIRMATION PROCEDURE

1. Start engine and let it idle for at least 5 seconds.
2. Check 1st trip DTC.

#### Is 1st trip DTC detected?

- YES >> Proceed to [EC-1853, "Diagnosis Procedure"](#).  
 NO >> INSPECTION END

### Diagnosis Procedure

INFOID:000000007758393

#### 1. CHECK POWER STEERING PRESSURE SENSOR POWER SUPPLY-I

1. Disconnect power steering pressure (PSP) sensor connector.
2. Turn ignition switch ON.
3. Check the voltage between PSP sensor harness connector terminals.

| Connector | PSP sensor |   | Voltage<br>(Approx.) |
|-----------|------------|---|----------------------|
|           | +          | - |                      |
| F35       | 3          | 1 | 5 V                  |

#### Inspection result normal?

- YES >> GO TO 6.  
 NO >> GO TO 2.

#### 2. CHECK POWER STEERING PRESSURE SENSOR POWER SUPPLY-II

Check the voltage between PSP sensor harness connector and the ground.

# P0550 PSP SENSOR

< DTC/CIRCUIT DIAGNOSIS >

[VK56VD FOR MEXICO]

| +          |          | -      | Voltage<br>(Approx.) |
|------------|----------|--------|----------------------|
| PSP sensor |          |        |                      |
| Connector  | Terminal |        |                      |
| F35        | 3        | Ground | 5 V                  |

Is inspection result normal?

- YES >> GO TO 4.
- NO >> GO TO 3.

## 3.CHECK SENSOR POWER SUPPLY CIRCUIT

1. Turn ignition switch OFF.
2. Disconnect ECM harness connector.
3. Check harness connector for short to power and short to ground, between the following terminals.

| ECM       |          | Sensor                         |           |          |
|-----------|----------|--------------------------------|-----------|----------|
| Connector | Terminal | Name                           | Connector | Terminal |
| F110      | 27       | Power steering pressure sensor | F35       | 3        |
|           |          | Low fuel pressure sensor       | F39       | 3        |
|           | 28       | FRP sensor                     | F6        | 1        |
|           |          | Engine oil pressure sensor     | F32       | 3        |

Is inspection result normal?

- YES >> Perform the trouble diagnosis for power supply circuit. Refer to [EC-1707. "Diagnosis Procedure"](#).
- NO >> Repair or replace error-detected parts.

## 4.CHECK PSP SENSOR GROUND CIRCUIT

1. Turn ignition switch OFF.
2. Disconnect ECM harness connector.
3. Check the continuity between PSP sensor harness connector and ECM harness connector.

| +          |          | -         |          | Continuity |
|------------|----------|-----------|----------|------------|
| PSP sensor |          | ECM       |          |            |
| Connector  | Terminal | Connector | Terminal |            |
| F35        | 1        | F110      | 45       | Existed    |

Is inspection result normal?

- YES >> GO TO 5.
- NO >> Repair or replace error-detected parts.

## 5.CHECK ECM GROUND CIRCUIT

Check the continuity between ECM harness connector and ground.

| ECM       |          | Ground | Continuity |
|-----------|----------|--------|------------|
| Connector | Terminal |        |            |
| F110      | 10       | Ground | Existed    |
| M160      | 114      |        |            |
|           | 115      |        |            |
|           | 174      |        |            |
|           | 175      |        |            |

Is inspection result normal?

- YES >> Check intermittent incident. Refer to [GI-44. "Intermittent Incident"](#).
- NO >> Repair or replace error-detected parts.

# P0550 PSP SENSOR

< DTC/CIRCUIT DIAGNOSIS >

[VK56VD FOR MEXICO]

## 6. CHECK PSP SENSOR SIGNAL CIRCUIT

1. Turn ignition switch OFF.
2. Disconnect ECM harness connector.
3. Check the continuity between PSP sensor harness connector and ECM harness connector.

| +          |          | -         |          | Continuity |
|------------|----------|-----------|----------|------------|
| PSP sensor |          | ECM       |          |            |
| Connector  | Terminal | Connector | Terminal |            |
| F35        | 2        | F110      | 39       | Existed    |

4. Also check harness for short to ground and to power.

Is inspection result normal?

YES >> GO TO 7.

NO >> Repair or replace error-detected parts.

## 7. CHECK PSP SENSOR

Refer to [EC-1855, "Component Inspection \(Power Steering Pressure Sensor\)"](#).

Is inspection result normal?

YES >> Check intermittent incident. Refer to [GI-44, "Intermittent Incident"](#).

NO >> Repair or replace error-detected parts.

## Component Inspection (Power Steering Pressure Sensor)

INFOID:000000007758394

### 1. CHECK POWER STEERING PRESSURE SENSOR

1. Turn ignition switch OFF.
2. Reconnect all harness connectors disconnected.
3. Start engine and let it idle.
4. Check the voltage between ECM harness connector terminals under the following conditions.

| Connector | ECM      |          | Condition        | Voltage (V)  |           |
|-----------|----------|----------|------------------|--------------|-----------|
|           | +        | -        |                  |              |           |
|           | Terminal | Terminal |                  |              |           |
| F110      | 39       | 45       | Steering wheel   | Being turned | 0.5 - 4.5 |
|           |          |          | Not being turned | 0.4 - 0.8    |           |

Is the inspection result normal?

YES >> INSPECTION END

NO >> Replace power steering pressure sensor.

# P0603 ECM POWER SUPPLY

< DTC/CIRCUIT DIAGNOSIS >

[VK56VD FOR MEXICO]

## P0603 ECM POWER SUPPLY

### DTC Logic

INFOID:000000007758395

### DTC DETECTION LOGIC

| DTC No. | Trouble diagnosis name<br>(Trouble diagnosis content) | DTC detecting condition                            | Possible cause   |
|---------|---|--|--|
| P0603   | ECM BACK UP/CIRCUIT<br>(ECM power supply circuit)     | ECM back up RAM system does not function properly. | <ul style="list-style-type: none"><li>• Harness or connectors<br/>[ECM power supply (back up) circuit is open or shorted.]</li><li>• ECM</li></ul> |

### DTC CONFIRMATION PROCEDURE

#### 1. PRECONDITIONING

If DTC Confirmation Procedure has been previously conducted, always perform the following procedure before conducting the next test.

1. Turn ignition switch OFF and wait at least 10 seconds.
2. Turn ignition switch ON.
3. Turn ignition switch OFF and wait at least 10 seconds.

>> GO TO 2.

#### 2. PERFORM DTC CONFIRMATION PROCEDURE

1. Turn ignition switch ON wait at least 10 seconds.
2. Turn ignition switch OFF and wait at least 5 minutes.
3. Turn ignition switch ON, wait at least 10 seconds.
4. Repeat step 2 and 3 for five times.
5. Check 1st trip DTC.

Is 1st trip DTC detected?

- YES >> Proceed to [EC-1856. "Diagnosis Procedure"](#).  
NO >> INSPECTION END

### Diagnosis Procedure

INFOID:000000007758396

#### 1. CHECK ECM POWER SUPPLY

1. Turn ignition switch OFF.
2. Disconnect ECM harness connector.
3. Check the voltage between ECM harness connector terminals.

| ECM       |          |           |          | Voltage         |
|-----------|----------|-----------|----------|-----------------|
| +         |          | -         |          |                 |
| Connector | Terminal | Connector | Terminal |                 |
| M160      | 156      | M160      | 175      | Battery voltage |

Is the inspection result normal?

- YES >> GO TO 3.  
NO >> GO TO 2.

#### 2. DETECT MALFUNCTIONING PART

Check the following.

- 15 A fuse (No. 51)
- Harness for open or short between ECM and battery
- Loose or poor connection for each connector and harness

>> Repair or replace harness or connectors.



# P0603 ECM POWER SUPPLY

< DTC/CIRCUIT DIAGNOSIS >

[VK56VD FOR MEXICO]

## 3.CHECK INTERMITTENT INCIDENT

Refer to [GI-44, "Intermittent Incident"](#).

Is the inspection result normal?

YES >> GO TO 4.

NO >> Repair or replace harness or connectors.

## 4.PERFORM DTC CONFIRMATION PROCEDURE

1. Turn ignition switch ON.
2. Erase DTC.
3. Perform DTC Confirmation Procedure.  
See [EC-1856, "DTC Logic"](#).

Is the 1st trip DTC P0603 displayed again?

YES >> GO TO 5.

NO >> INSPECTION END

## 5.REPLACE ECM

Replace ECM. Refer to [EC-2013, "Removal and Installation"](#).

>> INSPECTION END

A

EC

C

D

E

F

G

H

I

J

K

L

M

N

O

P

P0605 ECM

DTC Logic

INFOID:000000007758397

DTC DETECTION LOGIC

| DTC No. | Trouble diagnosis name | DTC detecting condition |   | Possible cause |
|---------|------------------------|-------------------------|---|----------------|
| P0605   | Engine control module  | A)                      | ECM calculation function is malfunctioning.   | ECM            |
|         |                        | B)                      | ECM EEPROM system is malfunctioning.          |                |
|         |                        | C)                      | ECM self shut-off function is malfunctioning. |                |
|         |                        | D)                      | ECM temperature sensor is malfunctioning.     |                |

DTC CONFIRMATION PROCEDURE

1. PRECONDITIONING

1. Turn ignition switch OFF and wait at least 10 seconds.
2. Turn ignition switch ON.
3. Turn ignition switch OFF and wait at least 10 seconds.

**TESTING CONDITION:**

**Before performing the following procedure, confirm that battery voltage is 11 V or more at idle.**

>> GO TO 2.

2. PERFORM DTC CONFIRMATION PROCEDURE FOR MALFUNCTION A AND D

1. Turn ignition switch ON.
2. Check 1st trip DTC.

Is 1st trip DTC detected?

- YES >> Proceed to [EC-1858, "Diagnosis Procedure"](#).
- NO >> GO TO 3.

3. PERFORM DTC CONFIRMATION PROCEDURE FOR MALFUNCTION B

1. Turn ignition switch ON and wait at least 1 second.
2. Turn ignition switch OFF, wait at least 10 seconds, and then turn it ON.
3. Check 1st trip DTC.

Is 1st trip DTC detected?

- YES >> Proceed to [EC-1858, "Diagnosis Procedure"](#).
- NO >> GO TO 4.

4. PERFORM DTC CONFIRMATION PROCEDURE FOR MALFUNCTION C

1. Turn ignition switch ON and wait at least 1 second.
2. Turn ignition switch OFF, wait at least 10 seconds, and then turn it ON.
3. Repeat step 2 for 32 times.
4. Check 1st trip DTC.

Is 1st trip DTC detected?

- YES >> Proceed to [EC-1858, "Diagnosis Procedure"](#).
- NO >> INSPECTION END

Diagnosis Procedure

INFOID:000000007758398

1. INSPECTION START

1. Turn ignition switch ON.
2. Erase DTC.
3. Perform DTC Confirmation Procedure.  
See [EC-1858, "DTC Logic"](#).

Is the 1st trip DTC P0605 displayed again?

- YES >> GO TO 2.

# P0605 ECM

[VK56VD FOR MEXICO]

< DTC/CIRCUIT DIAGNOSIS >

NO >> INSPECTION END

**2.**REPLACE ECM

Replace ECM. Refer to [EC-2013, "Removal and Installation"](#).

>> INSPECTION END

A

EC

C

D

E

F

G

H

I

J

K

L

M

N

O

P

P0607 ECM

DTC Logic

INFOID:000000007758399

DTC DETECTION LOGIC

| DTC No. | Trouble diagnosis name<br>(Trouble diagnosis content) | DTC detecting condition   | Possible cause |
|---------|---|---|----------------|
| P0607   | ECM<br>(CAN communication bus)                        | When detecting error during the initial diagnosis of CAN controller of ECM. | ECM            |

DTC CONFIRMATION PROCEDURE

1. PERFORM DTC CONFIRMATION PROCEDURE

1. Turn ignition switch ON.
2. Check DTC.

Is DTC detected?

- YES >> Proceed to [EC-1860, "Diagnosis Procedure"](#).
- NO >> INSPECTION END

Diagnosis Procedure

INFOID:000000007758400

1. INSPECTION START

1. Turn ignition switch ON.
2. Erase DTC.
3. Perform DTC Confirmation Procedure.  
See [EC-1860, "DTC Logic"](#).
4. Check DTC.

Is the DTC P0607 displayed again?

- YES >> Replace ECM and perform additional service when replacing ECM. Refer to [EC-1683, "Work Procedure"](#).
- NO >> INSPECTION END

P0611 ECM PROTECTION

Description

INFOID:000000007758401

This DTC is detected when the ECM protective function is activated due to an extreme temperature increase in ECM, resulting from severe conditions such as heavy load driving.

A  
EC

DTC Logic

INFOID:000000007758402

DTC DETECTION LOGIC

| DTC No. | Trouble diagnosis name | DTC detecting condition                       | Possible cause |
|---------|------------------------|---|----------------|
| P0611   | ECM PROTECTION         | ECM overheat protection control is activated. | ECM overheated |

C  
D

DTC CONFIRMATION PROCEDURE

1.PERFORM DTC CONFIRMATION PROCEDURE

This DTC is displayed as protection function history. If no malfunction is detected after the diagnosis, the customer must be informed of the activation of the protection function.

E  
F

>> Proceed to [EC-1861, "Diagnosis Procedure"](#).

G

Diagnosis Procedure

INFOID:000000007758403

1.INSPECTION START

1. Perform DTC confirmation procedure. Refer to [EC-1858, "DTC Logic"](#).
2. Check 1st trip DTC.

H  
I

Is DTC P0605 detected?

- YES >> Proceed to [EC-1858, "Diagnosis Procedure"](#).
- NO >> Explain the customer about the activation of the protection function.

J  
K

L

M

N

O

P

P062B ECM

Description

INFOID:000000007758404

This DTC is detected when the ECM-integrated injector driver unit has a malfunction. For injector driver unit, refer to [EC-1572, "ECM"](#).

DTC Logic

INFOID:000000007758405

DTC DETECTION LOGIC

| DTC No. | Trouble diagnosis name                                    | DTC detecting condition                 | Possible cause   |
|---------|---|---|--|
| P062B   | Internal control module fuel injector control performance | Injector driver unit is malfunctioning. | <ul style="list-style-type: none"> <li>• Harness and connectors (Injector circuit is open or shorted)</li> <li>• Battery power supply</li> <li>• ECM (injector driver unit)</li> </ul> |

DTC CONFIRMATION PROCEDURE

1. PRECONDITIONING

1. Turn ignition switch OFF and wait at least 10 seconds.
2. Turn ignition switch ON.
3. Turn ignition switch OFF and wait at least 10 seconds.

**TESTING CONDITION:**

**Before performing the following procedure, confirm that battery voltage is 11 V or more at idle.**

>> GO TO 2.

2. PERFORM DTC CONFIRMATION PROCEDURE

1. Start the engine and keep the engine speed at idle for 30 seconds.
2. Check 1st trip DTC.

Is 1st trip DTC detected?

YES >> Proceed to [EC-1862, "Diagnosis Procedure"](#).

NO >> INSPECTION END

Diagnosis Procedure

INFOID:000000007758406

1. CHECK FUEL INJECTOR

Check fuel injector. Refer to [EC-1976, "Component Function Check"](#).

Is inspection result normal?

YES >> GO TO 2.

NO >> Repair or replace error-detected parts.

2. PERFORM DTC CONFIRMATION PROCEDURE

1. Turn ignition switch ON.
2. Erase DTC.
3. Perform DTC confirmation procedure again. Refer to [EC-1862, "DTC Logic"](#).
4. Check 1st trip DTC.

Is the DTC P062B displayed again?

YES >> Replace ECM. Refer to [EC-2013, "Removal and Installation"](#).

NO >> INSPECTION END

# P0643 SENSOR POWER SUPPLY

< DTC/CIRCUIT DIAGNOSIS >

[VK56VD FOR MEXICO]

## P0643 SENSOR POWER SUPPLY

### DTC Logic

INFOID:000000007758407

### DTC DETECTION LOGIC

| DTC No. | Trouble diagnosis name<br>(Trouble diagnosis content)    | DTC detecting condition   | Possible cause  |
|---------|--|---|---|
| P0643   | SENSOR POWER/CIRC<br>(Sensor power supply circuit short) | ECM detects that the voltage of power source for sensor is excessively low or high. | <ul style="list-style-type: none"> <li>• Harness or connectors<br/>(Throttle position sensor circuit is shorted.)<br/>[Camshaft position sensor (bank 2) circuit is shorted.]<br/>(Manifold absolute pressure sensor circuit is shorted.)<br/>(Accelerator pedal position sensor 1 circuit is shorted.)</li> <li>• Throttle position sensor</li> <li>• Camshaft position sensor (bank 2)</li> <li>• Manifold absolute pressure sensor</li> <li>• Accelerator pedal position sensor 1</li> </ul> |

### DTC CONFIRMATION PROCEDURE

#### 1. PRECONDITIONING

1. Turn ignition switch OFF and wait at least 10 seconds.
2. Turn ignition switch ON.
3. Turn ignition switch OFF and wait at least 10 seconds.

#### TESTING CONDITION:

Before performing the following procedure, confirm that battery voltage is 8 V or more at idle.

>> GO TO 2.

#### 2. PERFORM DTC CONFIRMATION PROCEDURE

1. Start engine and let it idle for 1 second.
2. Check DTC.

#### Is DTC detected?

YES >> Proceed to [EC-1863. "Diagnosis Procedure"](#).

NO >> INSPECTION END

### Diagnosis Procedure

INFOID:000000007758408

#### 1. CHECK ACCELERATOR PEDAL POSITION SENSOR 1 POWER SUPPLY CIRCUIT

1. Disconnect accelerator pedal position (APP) sensor harness connector.
2. Turn ignition switch ON.
3. Check the voltage between APP sensor harness connector and ground.

| APP sensor       |          | Ground | Voltage (V) |
|------------------|----------|--------|-------------|
| Connector        | Terminal |        |             |
| M9 (Without ICC) | 5        | Ground | Approx. 5   |
| M153 (With ICC)  | 6        |        |             |

#### Is the inspection result normal?

YES >> GO TO 6.

NO >> GO TO 2.

#### 2. CHECK SENSOR POWER SUPPLY CIRCUIT

Check harness for short to power and short to ground, between the following terminals.

# P0643 SENSOR POWER SUPPLY

< DTC/CIRCUIT DIAGNOSIS >

[VK56VD FOR MEXICO]

| ECM       |          | Sensor                            |           |          |
|-----------|----------|-----------------------------------|-----------|----------|
| Connector | Terminal | Name                              | Connector | Terminal |
| F111      | 81       | Throttle position sensor (bank 1) | F66       | 2        |
|           | 82       | Throttle position sensor (bank 2) | F64       | 2        |
|           | 83       | Camshaft position sensor (bank 2) | F83       | 1        |
|           | 85       | Manifold absolute pressure sensor | F19       | 1        |
| M160      | 5        | APP sensor 1 (Without ICC)        | M9        | 5        |
|           | 6        | APP sensor 1 (With ICC)           | M153      | 6        |

Is the inspection result normal?

YES >> GO TO 3.

NO >> Repair short to ground or short to power in harness or connectors.

## 3.CHECK COMPONENTS

Check the following.

- Camshaft position sensor (bank 2) (Refer to [EC-1831, "Component Inspection \(Camshaft Position Sensor\)"](#).)
- Manifold absolute pressure sensor (Refer to [EC-1995, "Component Inspection"](#).)

Is the inspection result normal?

YES >> GO TO 4.

NO >> Replace malfunctioning component.

## 4.CHECK THROTTLE POSITION SENSOR

Refer to [EC-1814, "Component Inspection \(Throttle Position Sensor\)"](#).

Is the inspection result normal?

YES >> GO TO 8.

NO >> GO TO 5.

## 5.REPLACE ELECTRIC THROTTLE CONTROL ACTUATOR

Replace electric throttle control actuator. Refer to [EM-191, "Removal and Installation"](#).

>> INSPECTION END

## 6.CHECK ACCELERATOR PEDAL POSITION SENSOR

Refer to [EC-1952, "Component Inspection \(Accelerator Pedal Position Sensor\)"](#).

Is the inspection result normal?

YES >> GO TO 8.

NO >> GO TO 7.

## 7.REPLACE ACCELERATOR PEDAL ASSEMBLY

Replace accelerator pedal assembly.

Refer to [ACC-3, "MODELS WITHOUT DISTANCE CONTROL ASSIST SYSTEM : Removal and Installation"](#) (Without distance control assist system).

Refer to [ACC-4, "MODELS WITH DISTANCE CONTROL ASSIST SYSTEM : Removal and Installation"](#) (With distance control assist system).

>> INSPECTION END

## 8.CHECK INTERMITTENT INCIDENT

Refer to [GI-44, "Intermittent Incident"](#).

>> INSPECTION END



P0850 PNP SWITCH

Description

INFOID:000000007758409

When the selector lever position is P or N, park/neutral position (PNP) signal is sent to ECM from TCM.

A  
EC

DTC Logic

INFOID:000000007758410

DTC DETECTION LOGIC

C

| DTC No. | Trouble diagnosis name<br>(Trouble diagnosis content) | DTC detecting condition  | Possible cause  |
|---------|---|--|---|
| P0850   | P-N POS SW/CIRCUIT<br>(Park/neutral position switch)  | The signal of the park/neutral position (PNP) signal does not change during driving after the engine is started. | <ul style="list-style-type: none"> <li>• Harness or connectors<br/>[The park/neutral position (PNP) signal circuit is open or shorted.]</li> <li>• TCM</li> </ul> |

D  
E

DTC CONFIRMATION PROCEDURE

1.INSPECTION START

F

Will CONSULT be used?

Will CONSULT be used?

G

- YES >> GO TO 2.
- NO >> GO TO 5.

2.PRECONDITIONING

H

If DTC Confirmation Procedure has been previously conducted, always perform the following procedure before conducting the next test.

1. Turn ignition switch OFF and wait at least 10 seconds.
2. Turn ignition switch ON.
3. Turn ignition switch OFF and wait at least 10 seconds.

I  
J

>> GO TO 3.

3.CHECK PNP SIGNAL

K

Ⓜ WITH CONSULT

1. Turn ignition switch ON.
2. Select "P/N POSI SW" in "DATA MONITOR" mode with CONSULT. Then check the "P/N POSI SW" signal under the following conditions.

L

| Position (Selector lever) | Known-good signal |
|---------------------------|-------------------|
| N or P position           | ON                |
| Except above position     | OFF               |

M

Is the inspection result normal?

N

- YES >> GO TO 4.
- NO >> Proceed to [EC-1866, "Diagnosis Procedure"](#).

4.PERFORM DTC CONFIRMATION PROCEDURE

O

1. Select "DATA MONITOR" mode with CONSULT.
2. Start engine and warm it up to normal operating temperature.
3. Maintain the following conditions for at least 50 consecutive seconds.

P

**CAUTION:**

**Always drive vehicle at a safe speed.**

|               |                        |
|---------------|------------------------|
| ENG SPEED     | 1,300 - 6,375 rpm      |
| COOLAN TEMP/S | More than 70°C (158°F) |

# P0850 PNP SWITCH

[VK56VD FOR MEXICO]

## < DTC/CIRCUIT DIAGNOSIS >

|                |                            |
|----------------|----------------------------|
| B/FUEL SCHDL   | 2.0 - 31.8 msec            |
| VHCL SPEED SE  | More than 64 km/h (40 mph) |
| Selector lever | Suitable position          |

### 4. Check 1st trip DTC.

#### Is 1st trip DTC detected?

YES >> Proceed to [EC-1866, "Diagnosis Procedure"](#).

NO >> INSPECTION END

## 5. PERFORM COMPONENT FUNCTION CHECK

### WITH GST

Perform Component Function Check. Refer to [EC-1866, "Component Function Check"](#).

#### **NOTE:**

Use Component Function Check to check the overall function of the park/neutral position (PNP) signal circuit. During this check, a 1st trip DTC might not be confirmed.

#### Is the inspection result normal?

YES >> INSPECTION END

NO >> Proceed to [EC-1866, "Diagnosis Procedure"](#).

## Component Function Check

INFOID:000000007758411

## 1. PERFORM COMPONENT FUNCTION CHECK

### With GST

1. Turn ignition switch ON.
2. Check the voltage between ECM harness connector terminals under the following conditions.

| ECM       |          |          | Condition      | Voltage (V)           |                 |
|-----------|----------|----------|----------------|-----------------------|-----------------|
| Connector | +        | -        |                |                       |                 |
|           | Terminal | Terminal |                |                       |                 |
| F110      | 11       | 175      | Selector lever | P or N position       | Battery voltage |
|           |          |          |                | Except above position | Approx. 0 V     |

#### Is the inspection result normal?

YES >> INSPECTION END

NO >> Proceed to [EC-1866, "Diagnosis Procedure"](#).

## Diagnosis Procedure

INFOID:000000007758412

## 1. CHECK DTC WITH TCM

Refer to [TM-60, "CONSULT Function"](#).

#### Is the inspection result normal?

YES >> GO TO 2.

NO >> Repair or replace malfunctioning part.

## 2. CHECK STARTING SYSTEM

Turn ignition switch OFF, then turn it to START.

#### Does starter motor operate?

YES >> GO TO 3.

NO >> Check DTC with BCM. Refer to [BCS-15, "COMMON ITEM : CONSULT Function \(BCM - COMMON ITEM\)"](#).

## 3. CHECK PNP SIGNAL CIRCUIT FOR OPEN AND SHORT

1. Turn ignition switch OFF.
2. Disconnect A/T assembly harness connector.
3. Disconnect ECM harness connector.
4. Check the continuity between A/T assembly harness connector and ECM harness connector.

# P0850 PNP SWITCH

[VK56VD FOR MEXICO]

< DTC/CIRCUIT DIAGNOSIS >

| A/T assembly |          | ECM       |          | Continuity |
|--------------|----------|-----------|----------|------------|
| Connector    | Terminal | Connector | Terminal |            |
| F301         | 9        | F110      | 11       | Existed    |

5. Also check harness for short to ground and short to power.

Is the inspection result normal?

- YES >> GO TO 5.
- NO >> GO TO 4.

## 4. DETECT MALFUNCTIONING PART

Check the following.

- Harness for open or short between A/T assembly and ECM
- Loose or poor connection for each connector and harness

>> Repair open circuit, short to ground or short to power in harness or connectors.

## 5. CHECK INTERMITTENT INCIDENT

Refer to [GI-44, "Intermittent Incident"](#).

>> INSPECTION END

A

EC

C

D

E

F

G

H

I

J

K

L

M

N

O

P

# P100A, P100B VVEL SYSTEM

[VK56VD FOR MEXICO]

< DTC/CIRCUIT DIAGNOSIS >

## P100A, P100B VVEL SYSTEM

### DTC Logic

INFOID:000000007758413

#### DTC DETECTION LOGIC

##### NOTE:

If DTC P100A or P100B is displayed with DTC P1090 or P1093, first perform the trouble diagnosis for DTC P1090 or P1093. Refer to [EC-1882, "DTC Logic"](#).

| DTC No. | Trouble diagnosis name<br>(Trouble diagnosis content)     | DTC detecting condition                  | Possible cause  |
|---------|---|--|---|
| P100A   | VVEL SYSTEM-B1<br>[VVEL response malfunction<br>(bank 1)] | Actual event response to target is poor. | <ul style="list-style-type: none"><li>• Harness or connectors<br/>(VVEL actuator motor circuit is open or shorted.)</li><li>• VVEL actuator motor</li><li>• VVEL actuator sub assembly</li><li>• VVEL ladder assembly</li><li>• VVEL control module</li></ul> |
| P100B   | VVEL SYSTEM-B2<br>[VVEL response malfunction<br>(bank 2)] |  |   |

#### DTC CONFIRMATION PROCEDURE

##### 1. PRECONDITIONING

1. Turn ignition switch OFF and wait at least 10 seconds.
2. Turn ignition switch ON.
3. Turn ignition switch OFF and wait at least 10 seconds.

##### TESTING CONDITION:

Before performing the following procedure, confirm that battery voltage is 10 V or more at idle.

>> GO TO 2.

##### 2. PERFORM DTC CONFIRMATION PROCEDURE

1. Start engine.
2. Depress the accelerator pedal rapidly half or more under no load conditions, and then release it.
3. Wait at idle for 5 seconds or more.
4. Repeat steps 2 to 3 for three times.
5. Check 1st trip DTC.

##### Is DTC detected?

- YES >> Proceed to [EC-1868, "Diagnosis Procedure"](#).  
NO >> INSPECTION END

#### Diagnosis Procedure

INFOID:000000007758414

##### 1. VVEL ACTUATOR MOTOR OUTPUT SIGNAL CIRCUIT FOR OPEN AND SHORT

1. Disconnect VVEL control module harness connector.
2. Disconnect VVEL actuator motor harness connector.
3. Check the continuity between VVEL control module harness connector and VVEL actuator motor harness connector.

# P100A, P100B VVEL SYSTEM

< DTC/CIRCUIT DIAGNOSIS >

[VK56VD FOR MEXICO]

| DTC No. | VVEL control module |           |          | VVEL actuator motor |          | Continuity  |             |
|---------|---------------------|-----------|----------|---------------------|----------|-------------|-------------|
|         | Bank                | Connector | Terminal | Connector           | Terminal |             |             |
| P100A   | 1                   | E15       | 12       | F73                 | 1        | Existed     |             |
|         |                     |           |          |                     | 2        | Not existed |             |
|         |                     |           | 25       |                     | 1        | Not existed |             |
|         |                     |           |          |                     | 2        | Existed     |             |
| P100B   | 2                   |           |          | 2                   | F71      | 1           | Existed     |
|         |                     |           |          |                     |          | 2           | Not existed |
|         |                     |           |          | 15                  |          | 1           | Not existed |
|         |                     |           |          |                     |          | 2           | Existed     |

4. Also check harness for short to ground and power.

Is the inspection result normal?

YES >> GO TO 3.

NO >> GO TO 2.

## 2. DETECT MALFUNCTIONING PART

Check the following.

- Harness for open or short between VVEL actuator motor and VVEL control module
- Loose or poor connection for each connector and harness

>> Repair open circuit, short to ground or short to power in harness or connectors.

## 3. CHECK VVEL ACTUATOR MOTOR

Refer to [EC-1870. "Component Inspection \(VVEL ACTUATOR MOTOR\)"](#).

Is the inspection result normal?

YES >> GO TO 5.

NO >> GO TO 4.

## 4. REPLACE VVEL ACTUATOR SUB ASSEMBLY

Replace VVEL actuator sub assembly. Refer to [EM-246. "Exploded View"](#).

>> INSPECTION END

## 5. CHECK INTERMITTENT INCIDENT

Refer to [GI-44. "Intermittent Incident"](#).

Is the inspection result normal?

YES >> GO TO 6.

NO >> Repair or replace.

## 6. REPLACE VVEL CONTROL MODULE

Replace VVEL control module. Refer to [EC-2014. "Removal and Installation"](#).

>> GO TO 7.

## 7. PERFORM DTC CONFIRMATION PROCEDURE

1. Turn ignition switch ON.
2. Erase 1st trip DTC.
3. Perform DTC Confirmation Procedure.  
See [EC-1868. "DTC Logic"](#).

Is the DTC P100A or P100B displayed again?

YES >> GO TO 8.

NO >> INSPECTION END

8.CHECK VVEL ACTUATOR SUB ASSEMBLY

Refer to [EC-1870, "Component Inspection \(VVEL ACTUATOR SUB ASSEMBLY\)"](#).

Is the inspection result normal?

- YES >> GO TO 10.
- NO >> GO TO 9.

9.REPLACE VVEL ACTUATOR SUB ASSEMBLY

Replace VVEL actuator sub assembly. Refer to [EM-246, "Exploded View"](#).

>> INSPECTION END

10.CHECK VVEL LADDER ASSEMBLY

Refer to [EM-246, "Exploded View"](#).

Is the inspection result normal?

- YES >> GO TO 12.
- NO >> GO TO 11.

11.REPLACE CYLINDER HEAD, VVEL LADDER ASSEMBLY AND VVEL ACTUATOR SUB ASSEMBLY

Replace cylinder head, VVEL ladder assembly and VVEL actuator sub assembly.  
 Refer to [EM-265, "Disassembly and Assembly"](#) (Cylinder head).  
 Refer to [EM-246, "Exploded View"](#) (VVEL ladder assembly and VVEL actuator sub assembly)

>> INSPECTION END

12.CHECK INTERMITTENT INCIDENT

Refer to [GI-44, "Intermittent Incident"](#).

>> INSPECTION END

Component Inspection (VVEL ACTUATOR MOTOR)

INFOID:000000007758415

1.CHECK VVEL ACTUATOR MOTOR

1. Turn ignition switch OFF.
2. Disconnect VVEL actuator motor harness connector.
3. Check resistance between VVEL actuator motor terminals as per the following.

| VVEL actuator motor | Resistance   |
|---------------------|--------------|
| Terminal            |              |
| 1 and 2             | 16 Ω or less |

Is the inspection result normal?

- YES >> INSPECTION END
- NO >> GO TO 2.

2.REPLACE VVEL ACTUATOR SUB ASSEMBLY

Replace VVEL actuator sub assembly. Refer to [EM-246, "Exploded View"](#).

>> INSPECTION END

Component Inspection (VVEL ACTUATOR SUB ASSEMBLY)

INFOID:000000007758416

1.CHECK VVEL ACTUATOR SUB ASSEMBLY

1. Turn ignition switch OFF.
2. Remove VVEL actuator sub assembly. Refer to [EM-246, "Exploded View"](#).
3. Turn the ball screw shaft to check that it works smoothly.

# P100A, P100B VVEL SYSTEM

[VK56VD FOR MEXICO]

< DTC/CIRCUIT DIAGNOSIS >

Is the inspection result normal?

YES >> INSPECTION END

NO >> GO TO 2.

## 2.REPLACE VVEL ACTUATOR SUB ASSEMBLY

Replace VVEL actuator sub assembly. Refer to [EM-246. "Exploded View"](#).

>> INSPECTION END

A

EC

C

D

E

F

G

H

I

J

K

L

M

N

O

P

# P1078, P1084 EVT CONTROL POSITION SENSOR

< DTC/CIRCUIT DIAGNOSIS >

[VK56VD FOR MEXICO]

## P1078, P1084 EVT CONTROL POSITION SENSOR

### DTC Logic

INFOID:000000007758417

### DTC DETECTION LOGIC

| DTC No. | Trouble diagnosis name<br>(Trouble diagnosis content)                                  | DTC detecting condition  | Possible cause   |
|---------|--|--|--|
| P1078   | EXH TIM SEN/CIRC-B1<br>[Exhaust valve timing control position sensor (bank 1) circuit] | An excessively high or low voltage from the sensor is sent to ECM. | <ul style="list-style-type: none"> <li>• Harness or connectors<br/>[Exhaust valve timing control position sensor (bank 1) circuit is open or shorted]</li> <li>• Exhaust valve timing control position sensor (bank 1)</li> <li>• Crankshaft position sensor</li> <li>• Camshaft position sensor (bank 1)</li> <li>• Accumulation of debris to the signal pick-up portion of the camshaft</li> </ul> |
| P1084   | EXH TIM SEN/CIRC-B2<br>[Exhaust valve timing control position sensor (bank 2) circuit] |  | <ul style="list-style-type: none"> <li>• Harness or connectors<br/>[Exhaust valve timing control position sensor (bank 2) circuit is open or shorted]</li> <li>• Exhaust valve timing control position sensor (bank 2)</li> <li>• Crankshaft position sensor</li> <li>• Camshaft position sensor (bank 2)</li> <li>• Accumulation of debris to the signal pick-up portion of the camshaft</li> </ul> |

### DTC CONFIRMATION PROCEDURE

#### 1. PRECONDITIONING

If DTC Confirmation Procedure has been previously conducted, always perform the following procedure before conducting the next test.

1. Turn ignition switch OFF and wait at least 10 seconds.
2. Turn ignition switch ON.
3. Turn ignition switch OFF and wait at least 10 seconds.

>> GO TO 2.

#### 2. PERFORM DTC CONFIRMATION PROCEDURE

1. Start engine and let it idle for 10 seconds.
2. Check 1st trip DTC.

Is 1st trip DTC detected?

- YES >> Proceed to [EC-1872, "Diagnosis Procedure"](#).  
 NO >> INSPECTION END

### Diagnosis Procedure

INFOID:000000007758418

#### 1. CHECK EXHAUST VALVE TIMING CONTROL POSITION SENSOR POWER SUPPLY CIRCUIT-I

1. Disconnect exhaust valve timing (EVT) control position sensor harness connector.
2. Turn ignition switch ON.
3. Check the voltage between exhaust valve timing control position sensor harness connector and ground.

| DTC   | EVT control position sensor |           |          | Ground | Voltage (V) |
|-------|-----------------------------|-----------|----------|--------|-------------|
|       | Bank                        | Connector | Terminal |        |             |
| P1078 | 1                           | F59       | 1        | Ground | Approx. 5   |
| P1084 | 2                           | F63       | 1        |        |             |

Is the inspection result normal?

- YES >> GO TO 2.  
 NO >> Repair open circuit, short to ground in harness or connectors.



# P1078, P1084 EVT CONTROL POSITION SENSOR

< DTC/CIRCUIT DIAGNOSIS >

[VK56VD FOR MEXICO]

## 2. CHECK EVT CONTROL POSITION SENSOR GROUND CIRCUIT FOR OPEN AND SHORT

1. Turn ignition switch OFF.
2. Disconnect ECM harness connector.
3. Check the continuity between EVT control position sensor harness connector and ECM harness connector.

| DTC   | EVT control position sensor |           |          | ECM       |          | Continuity |
|-------|-----------------------------|-----------|----------|-----------|----------|------------|
|       | Bank                        | Connector | Terminal | Connector | Terminal |            |
| P1078 | 1                           | F59       | 2        | F111      | 68       | Existed    |
| P1084 | 2                           | F63       | 2        | F111      | 99       |            |

4. Also check harness for short to power.

Is the inspection result normal?

YES >> GO TO 3.

NO >> Repair open circuit, short to power in harness or connectors.

## 3. CHECK EVT CONTROL POSITION SENSOR INPUT SIGNAL CIRCUIT FOR OPEN AND SHORT

1. Check the continuity between EVT control position sensor harness connector and ECM harness connector.

| DTC   | EVT control position sensor |           |          | ECM       |          | Continuity |
|-------|-----------------------------|-----------|----------|-----------|----------|------------|
|       | Bank                        | Connector | Terminal | Connector | Terminal |            |
| P1078 | 1                           | F59       | 3        | F111      | 75       | Existed    |
| P1084 | 2                           | F63       | 3        |           | 93       |            |

2. Also check harness for short to ground and short to power.

Is the inspection result normal?

YES >> GO TO 4.

NO >> Repair open circuit, short to ground or short to power in harness or connectors.

## 4. CHECK EXHAUST VALVE TIMING CONTROL POSITION SENSOR

Refer to [EC-1874, "Component Inspection \(Exhaust Valve Timing Control Position Sensor\)"](#).

Is the inspection result normal?

YES >> GO TO 5.

NO >> Replace malfunctioning exhaust valve timing control position sensor. Refer to [EM-231, "Exploded View"](#).

## 5. CHECK CRANKSHAFT POSITION SENSOR

Refer to [EC-1826, "Component Inspection \(Crankshaft Position Sensor\)"](#).

Is the inspection result normal?

YES >> GO TO 6.

NO >> Replace crankshaft position sensor. Refer to [EM-226, "Exploded View"](#).

## 6. CHECK CAMSHAFT POSITION SENSOR

Refer to [EC-1831, "Component Inspection \(Camshaft Position Sensor\)"](#).

Is the inspection result normal?

YES >> GO TO 7.

NO >> Replace malfunctioning camshaft position sensor. Refer to [EM-231, "Exploded View"](#).

## 7. CHECK CAMSHAFT SPROCKET (SIGNAL PLATE)

Check the following.

# P1078, P1084 EVT CONTROL POSITION SENSOR

[VK56VD FOR MEXICO]

## < DTC/CIRCUIT DIAGNOSIS >

- Accumulation of debris to the signal plate of camshaft sprocket (EXH)
- Chipping signal plate of camshaft sprocket (EXH)

### Is the inspection result normal?

YES >> GO TO 8.

NO >> Remove debris and clean the signal plate of camshaft sprocket (EXH) or replace camshaft sprocket (EXH). Refer to [EM-247, "Disassembly and Assembly"](#).

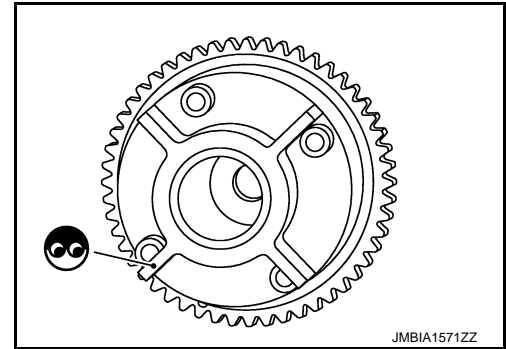

## 8. CHECK INTERMITTENT INCIDENT

Refer to [GI-44, "Intermittent Incident"](#).

>> INSPECTION END

## Component Inspection (Exhaust Valve Timing Control Position Sensor)

INFOID:000000007758419

### 1. EXHAUST VALVE TIMING CONTROL POSITION SENSOR-I

1. Turn ignition switch OFF.
2. Disconnect exhaust valve timing control position sensor harness connector.
3. Loosen the fixing bolt of the sensor.
4. Remove the sensor.
5. Visually check the sensor for chipping.

### Is the inspection result normal?

YES >> GO TO 2.

NO >> Replace malfunctioning exhaust valve timing control position sensor. Refer to [EM-231, "Exploded View"](#).

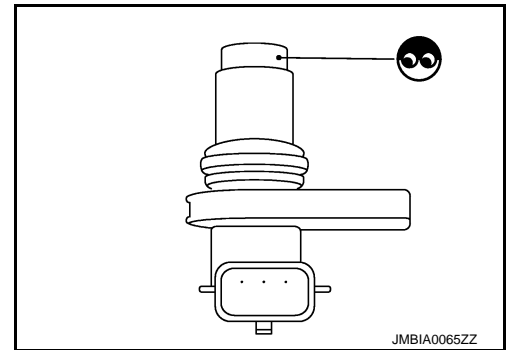

### 2. EXHAUST VALVE TIMING CONTROL POSITION SENSOR-II

Check resistance exhaust valve timing control position sensor terminals as shown below.

| Terminals     | Resistance                                     |
|---------------|--|
| 1 (+) - 2 (-) | Except 0 or $\infty$ $\Omega$ [at 25°C (77°F)] |
| 1 (+) - 3 (-) |  |
| 2 (+) - 3 (-) |  |

### Is the inspection result normal?

YES >> INSPECTION END

NO >> Replace malfunctioning exhaust valve timing control position sensor. Refer to [EM-231, "Exploded View"](#).

# P1087, P1088 VVEL SYSTEM

< DTC/CIRCUIT DIAGNOSIS >

[VK56VD FOR MEXICO]

## P1087, P1088 VVEL SYSTEM

### DTC Logic

INFOID:000000007758420

### DTC DETECTION LOGIC

**NOTE:**

If DTC P1087 or P1088 is displayed with DTC P1090 or P1093.

Perform the trouble diagnosis for DTC P1090 or P1093. Refer to [EC-1879, "DTC Logic"](#).

| DTC No. | Trouble diagnosis name<br>(Trouble diagnosis content)              | DTC detecting condition                                   | Possible cause  |
|---------|--|---|---|
| P1087   | VVEL SYSTEM-B1<br>[VVEL small event angle malfunction<br>(bank 1)] | The event angle of VVEL control<br>shaft is always small. | <ul style="list-style-type: none"><li>• Harness or connectors<br/>(VVEL actuator motor circuit is<br/>open or shorted.)</li><li>• VVEL actuator motor</li><li>• VVEL actuator sub assembly</li><li>• VVEL ladder assembly</li><li>• VVEL control module</li></ul> |
| P1088   | VVEL SYSTEM-B2<br>[VVEL small event angle malfunction<br>(bank 2)] |   |   |

### Diagnosis Procedure

INFOID:000000007758421

If DTC P1087 or P1088 is displayed with DTC P1090 or P1093.

Perform the trouble diagnosis for DTC P1090 or P1093. Refer to [EC-1879, "DTC Logic"](#).

# P1089, P1092 VVEL CONTROL SHAFT POSITION SENSOR

< DTC/CIRCUIT DIAGNOSIS >

[VK56VD FOR MEXICO]

## P1089, P1092 VVEL CONTROL SHAFT POSITION SENSOR

### DTC Logic

INFOID:000000007758422

#### DTC DETECTION LOGIC

##### NOTE:

If DTC P1089 or P1092 is displayed with DTC P1608, first perform the trouble diagnosis for DTC P1608. Refer to [EC-1942. "DTC Logic"](#).

| DTC No. | Trouble diagnosis name<br>(Trouble diagnosis content)                         | DTC detecting condition  | Possible cause  |
|---------|---|--|---|
| P1089   | VVEL POS SEN/CIRC-B1<br>[VVEL control shaft position sensor (bank 1) circuit] | <ul style="list-style-type: none"><li>An excessively low voltage from the sensor is sent to VVEL control module.</li><li>An excessively high voltage from the sensor is sent to VVEL control module.</li><li>Rationally incorrect voltage is sent to VVEL control module compared with the signals from VVEL control shaft position sensor 1 and VVEL control shaft position sensor 2.</li></ul> | <ul style="list-style-type: none"><li>Harness or connectors (VVEL control shaft position sensor circuit is open or shorted.)</li><li>VVEL control shaft position sensor</li><li>VVEL control module</li></ul> |
| P1092   | VVEL POS SEN/CIRC-B2<br>[VVEL control shaft position sensor (bank 2) circuit] |  |   |

#### DTC CONFIRMATION PROCEDURE

##### 1. PRECONDITIONING

- Turn ignition switch OFF and wait at least 10 seconds.
- Turn ignition switch ON.
- Turn ignition switch OFF and wait at least 10 seconds.

##### TESTING CONDITION:

Before performing the following procedure, confirm that battery voltage is 10 V or more at idle.

>> GO TO 2.

##### 2. PERFORM DTC CONFIRMATION PROCEDURE

- Start engine and let it idle for 1 second.
- Check DTC.

##### Is DTC detected?

- YES >> Proceed to [EC-1876. "Diagnosis Procedure"](#).  
NO >> INSPECTION END

#### Diagnosis Procedure

INFOID:000000007758423

##### 1. VVEL CONTROL SHAFT POSITION SENSOR POWER SUPPLY CIRCUIT

- Disconnect VVEL control shaft position sensor harness connector.
- Turn ignition switch ON.
- Check the voltage between VVEL control shaft position sensor harness connector and ground.

| DTC No. | VVEL control shaft position sensor |           |          | Ground | Voltage (V) |
|---------|------------------------------------|-----------|----------|--------|-------------|
|         | Bank                               | Connector | Terminal |        |             |
| P1089   | 1                                  | F72       | 3        | Ground | Approx. 5   |
|         |                                    |           | 6        |        |             |
| P1092   | 2                                  | F70       | 3        |        |             |
|         |                                    |           | 6        |        |             |

##### Is the inspection result normal?

- YES >> GO TO 3.  
NO >> GO TO 2.

##### 2. DETECT MALFUNCTIONING PART

Check the following.

# P1089, P1092 VVEL CONTROL SHAFT POSITION SENSOR

< DTC/CIRCUIT DIAGNOSIS >

[VK56VD FOR MEXICO]

- Harness for open or short between VVEL control shaft position sensor and VVEL control module
- Loose or poor connection for each connector and harness

>> Repair open circuit, short to ground or short to power in harness or connectors.

## 3. CHECK VVEL CONTROL SHAFT POSITION SENSOR GROUND CIRCUIT FOR OPEN AND SHORT

1. Turn ignition switch OFF.
2. Disconnect VVEL control module harness connector.
3. Check the continuity between VVEL control shaft position sensor harness connector and VVEL control module harness connector.

| DTC No. | VVEL control shaft position sensor |           |          | VVEL control module |          | Continuity |
|---------|------------------------------------|-----------|----------|---------------------|----------|------------|
|         | Bank                               | Connector | Terminal | Connector           | Terminal |            |
| P1089   | 1                                  | F72       | 2        | E15                 | 6        | Existed    |
|         |                                    |           | 5        |                     | 19       |            |
| P1092   | 2                                  | F70       | 2        |                     | 4        |            |
|         |                                    |           | 5        |                     | 17       |            |

4. Also check harness for short to power.

Is the inspection result normal?

YES >> GO TO 5.

NO >> GO TO 4.

## 4. DETECT MALFUNCTIONING PART

Check the following.

- Harness for open or short between VVEL control shaft position sensor and VVEL control module
- Loose or poor connection for each connector and harness

>> Repair open circuit, short to ground or short to power in harness or connectors.

## 5. VVEL CONTROL SHAFT POSITION SENSOR INPUT SIGNAL CIRCUIT FOR OPEN AND SHORT

1. Check the continuity between VVEL control shaft position sensor harness connector and VVEL control module harness connector.

| DTC No. | VVEL control shaft position sensor |           |          | VVEL control module |          | Continuity |
|---------|------------------------------------|-----------|----------|---------------------|----------|------------|
|         | Bank                               | Connector | Terminal | Connector           | Terminal |            |
| P1089   | 1                                  | F72       | 1        | E15                 | 3        | Existed    |
|         |                                    |           | 4        |                     | 16       |            |
| P1092   | 2                                  | F70       | 1        |                     | 5        |            |
|         |                                    |           | 4        |                     | 18       |            |

2. Also check harness for short to ground and power.

Is the inspection result normal?

YES >> GO TO 7.

NO >> GO TO 6.

## 6. DETECT MALFUNCTIONING PART

Check the following.

- Harness for open or short between VVEL control shaft position sensor and VVEL control module
- Loose or poor connection for each connector and harness

>> Repair open circuit, short to ground or short to power in harness or connectors.

## 7. CHECK INTERMITTENT INCIDENT

Refer to [GI-44, "Intermittent Incident"](#).

## P1089, P1092 VVEL CONTROL SHAFT POSITION SENSOR

< DTC/CIRCUIT DIAGNOSIS >

[VK56VD FOR MEXICO]

---

Is the inspection result normal?

YES >> GO TO 8.

NO >> Repair or replace.

### 8.REPLACE VVEL CONTROL MODULE

---

Replace VVEL control module. Refer to [EC-2014, "Removal and Installation"](#).

>> GO TO 9.

### 9.PERFORM DTC CONFIRMATION PROCEDURE

---

1. Turn ignition switch ON.
2. Erase DTC.
3. Perform DTC Confirmation Procedure.  
See [EC-1876, "DTC Logic"](#).

Is the DTC P1089 or P1092 displayed again?

YES >> GO TO 10.

NO >> INSPECTION END

### 10.REPLACE VVEL ACTUATOR SUB ASSEMBLY

---

Replace VVEL actuator sub assembly. Refer to [EM-246, "Exploded View"](#).

>> INSPECTION END

# P1090, P1093 VVEL ACTUATOR MOTOR

< DTC/CIRCUIT DIAGNOSIS >

[VK56VD FOR MEXICO]

## P1090, P1093 VVEL ACTUATOR MOTOR

### DTC Logic

INFOID:000000007758424

### DTC DETECTION LOGIC

**NOTE:**

If DTC P1090 or P1093 is displayed with DTC P1091, first perform the trouble diagnosis for DTC P1091. Refer to [EC-1882. "DTC Logic"](#).

| DTC No. | Trouble diagnosis name<br>(Trouble diagnosis content)     | DTC detecting condition   | Possible cause  |
|---------|---|---|---|
| P1090   | VVEL ACTR MOT-B1<br>[VVEL system performance<br>(bank 1)] | <ul style="list-style-type: none"> <li>Event angle difference between the actual and the target is detected.</li> <li>Abnormal current is sent to VVEL actuator motor.</li> </ul> | <ul style="list-style-type: none"> <li>Harness or connectors (VVEL actuator motor circuit is open or shorted.)</li> <li>VVEL actuator motor</li> <li>VVEL actuator sub assembly</li> <li>VVEL ladder assembly</li> <li>VVEL control module</li> </ul> |
| P1093   | VVEL ACTR MOT-B2<br>[VVEL system performance<br>(bank 2)] |   |   |

### DTC CONFIRMATION PROCEDURE

#### 1. PRECONDITIONING

- Turn ignition switch OFF and wait at least 10 seconds.
- Turn ignition switch ON.
- Turn ignition switch OFF and wait at least 10 seconds.

**TESTING CONDITION:**

Before performing the following procedure, confirm that battery voltage is 10 V or more at idle.

>> GO TO 2.

#### 2. PERFORM DTC CONFIRMATION PROCEDURE

- Start engine and let it idle for 10 second.
- Keep the engine speed at approximately 3,500 rpm for at least 10 seconds under no load.
- Check DTC.

Is DTC detected?

- YES >> Proceed to [EC-1879. "Diagnosis Procedure"](#).  
 NO >> INSPECTION END

### Diagnosis Procedure

INFOID:000000007758425

#### 1. VVEL ACTUATOR MOTOR OUTPUT SIGNAL CIRCUIT FOR OPEN AND SHORT

- Disconnect VVEL control module harness connector.
- Disconnect VVEL actuator motor harness connector.
- Check the continuity between VVEL control module harness connector and VVEL actuator motor harness connector.

| DTC No. | VVEL control module |           |          | VVEL actuator motor |          | Continuity  |
|---------|---------------------|-----------|----------|---------------------|----------|-------------|
|         | Bank                | Connector | Terminal | Connector           | Terminal |             |
| P1090   | 1                   | E15       | 12       | F73                 | 1        | Existed     |
|         |                     |           |          |                     | 2        | Not existed |
|         |                     |           | 25       |                     | 1        | Not existed |
|         |                     |           |          |                     | 2        | Existed     |
| P1093   | 2                   |           | 2        | F71                 | 1        | Existed     |
|         |                     |           |          |                     | 2        | Not existed |
|         |                     |           | 15       |                     | 1        | Not existed |
|         |                     |           |          |                     | 2        | Existed     |

## P1090, P1093 VVEL ACTUATOR MOTOR

[VK56VD FOR MEXICO]

< DTC/CIRCUIT DIAGNOSIS >

4. Also check harness for short to ground and power.

Is the inspection result normal?

YES >> GO TO 3.

NO >> GO TO 2.

### 2.DETECT MALFUNCTIONING PART

Check the following.

- Harness for open or short between VVEL actuator motor and VVEL control module
- Loose or poor connection for each connector and harness

>> Repair open circuit, short to ground or short to power in harness or connectors.

### 3.CHECK VVEL ACTUATOR MOTOR

Refer to [EC-1881, "Component Inspection \(VVEL ACTUATOR MOTOR\)"](#).

Is the inspection result normal?

YES >> GO TO 5.

NO >> GO TO 4.

### 4.REPLACE VVEL ACTUATOR SUB ASSEMBLY

Replace VVEL actuator sub assembly. Refer to [EM-246, "Exploded View"](#).

>> INSPECTION END

### 5.CHECK INTERMITTENT INCIDENT

Refer to [GI-44, "Intermittent Incident"](#).

Is the inspection result normal?

YES >> GO TO 6.

NO >> Repair or replace.

### 6.REPLACE VVEL CONTROL MODULE

Replace VVEL control module. Refer to [EC-2014, "Removal and Installation"](#).

>> GO TO 7.

### 7.PERFORM DTC CONFIRMATION PROCEDURE

1. Turn ignition switch ON.
2. Erase DTC.
3. Perform DTC Confirmation Procedure.  
See [EC-1879, "DTC Logic"](#).

Is the DTC P1090 or P1093 displayed again?

YES >> GO TO 8.

NO >> INSPECTION END

### 8.CHECK VVEL ACTUATOR SUB ASSEMBLY

Refer to [EC-1881, "Component Inspection \(VVEL ACTUATOR SUB ASSEMBLY\)"](#).

Is the inspection result normal?

YES >> GO TO 10.

NO >> GO TO 9.

### 9.REPLACE VVEL ACTUATOR SUB ASSEMBLY

Replace VVEL actuator sub assembly. Refer to [EM-246, "Exploded View"](#).

>> INSPECTION END

### 10.CHECK VVEL LADDER ASSEMBLY

Refer to [EM-246, "Exploded View"](#).



# P1090, P1093 VVEL ACTUATOR MOTOR

< DTC/CIRCUIT DIAGNOSIS >

[VK56VD FOR MEXICO]

Is the inspection result normal?

- YES >> GO TO 12.
- NO >> GO TO 11.

## 11. REPLACE CYLINDER HEAD, VVEL LADDER ASSEMBLY AND VVEL ACTUATOR SUB ASSEMBLY

Replace cylinder head, VVEL ladder assembly and VVEL actuator sub assembly.

Refer to [EM-265, "Disassembly and Assembly"](#) (Cylinder head)

Refer to [EM-246, "Exploded View"](#) (VVEL ladder assembly and VVEL actuator sub assembly).

>> INSPECTION END

## 12. CHECK INTERMITTENT INCIDENT

Refer to [GI-44, "Intermittent Incident"](#).

>> INSPECTION END

## Component Inspection (VVEL ACTUATOR MOTOR)

INFOID:0000000007758426

### 1. CHECK VVEL ACTUATOR MOTOR

1. Turn ignition switch OFF.
2. Disconnect VVEL actuator motor harness connector.
3. Check resistance between VVEL actuator motor terminals as per the following.

| VVEL actuator motor | Resistance   |
|---------------------|--------------|
| Terminal            |              |
| 1 and 2             | 16 Ω or less |

Is the inspection result normal?

- YES >> INSPECTION END
- NO >> GO TO 2.

### 2. REPLACE VVEL ACTUATOR SUB ASSEMBLY

Replace VVEL actuator sub assembly. Refer to [EM-246, "Exploded View"](#).

>> INSPECTION END

## Component Inspection (VVEL ACTUATOR SUB ASSEMBLY)

INFOID:0000000007758427

### 1. CHECK VVEL ACTUATOR SUB ASSEMBLY

1. Turn ignition switch OFF.
2. Remove VVEL actuator sub assembly. Refer to [EM-246, "Exploded View"](#).
3. Turn the ball screw shaft to check that it works smoothly.

Is the inspection result normal?

- YES >> INSPECTION END
- NO >> GO TO 2.

### 2. REPLACE VVEL ACTUATOR SUB ASSEMBLY

Replace VVEL actuator sub assembly. Refer to [EM-246, "Exploded View"](#).

>> INSPECTION END

# P1091 VVEL ACTUATOR MOTOR RELAY

< DTC/CIRCUIT DIAGNOSIS >

[VK56VD FOR MEXICO]

## P1091 VVEL ACTUATOR MOTOR RELAY

### DTC Logic

INFOID:000000007758428

### DTC DETECTION LOGIC

| DTC No. | Trouble diagnosis name<br>(Trouble diagnosis content)    | DTC detecting condition   | Possible cause   |
|---------|--|---|--|
| P1091   | VVEL ACTR MOT PWR<br>[VVEL actuator motor relay circuit] | <ul style="list-style-type: none"> <li>VVEL control module detects the VVEL actuator motor relay is stuck OFF.</li> <li>VVEL control module detects the VVEL actuator motor relay is stuck ON.</li> </ul> | <ul style="list-style-type: none"> <li>Harness or connectors (VVEL actuator motor relay circuit is open or shorted.) (Abort circuit is open or shorted.)</li> <li>VVEL actuator motor relay</li> <li>VVEL control module</li> <li>ECM</li> </ul> |

### DTC CONFIRMATION PROCEDURE

#### 1. PRECONDITIONING

- Turn ignition switch OFF and wait at least 10 seconds.
- Turn ignition switch ON.
- Turn ignition switch OFF and wait at least 10 seconds.

#### TESTING CONDITION:

Before performing the following procedure, confirm that battery voltage is 10 V or more at idle.

>> GO TO 2.

#### 2. PERFORM DTC CONFIRMATION PROCEDURE

- Turn ignition switch ON and wait at least 1 seconds.
- Turn ignition switch OFF and wait at least 10 seconds.
- Turn ignition switch ON and wait at least 1 seconds.
- Check 1st trip DTC.

Is 1st trip DTC detected?

- YES >> Proceed to [EC-1882, "Diagnosis Procedure"](#).
- NO >> INSPECTION END

### Diagnosis Procedure

INFOID:000000007758429

#### 1. VVEL ACTUATOR MOTOR RELAY POWER SUPPLY CIRCUIT-I

- Turn ignition switch OFF.
- Disconnect VVEL actuator motor relay.
- Check the voltage between VVEL actuator motor relay harness connector and ground.

| VVEL actuator motor relay |          | Ground | Voltage         |
|---------------------------|----------|--------|-----------------|
| Connector                 | Terminal |        |                 |
| E16                       | 1        | Ground | Battery voltage |
|                           | 5        |        |                 |

Is the inspection result normal?

- YES >> GO TO 3.
- NO >> GO TO 2.

#### 2. DETECT MALFUNCTIONING PART

Check the following.

- 50A fusible link (letter G)
- Harness for open or short between VVEL actuator motor relay and battery

>> Repair open circuit, short to ground or short to power in harness or connectors.

# P1091 VVEL ACTUATOR MOTOR RELAY

< DTC/CIRCUIT DIAGNOSIS >

[VK56VD FOR MEXICO]

## 3.VVEL ACTUATOR MOTOR RELAY POWER SUPPLY CIRCUIT-II

1. Disconnect VVEL control module harness connector.
2. Check the continuity between VVEL actuator motor relay harness connector and VVEL control module harness connector.

| VVEL control module |          | VVEL actuator motor relay |          | Continuity |
|---------------------|----------|---------------------------|----------|------------|
| Connector           | Terminal | Connector                 | Terminal |            |
| E15                 | 23       | E16                       | 2        | Existed    |

3. Also check harness for short to ground and power.

Is the inspection result normal?

YES >> GO TO 4.

NO >> Repair open circuit or short to ground or short to power in harness or connectors.

## 4.VVEL ACTUATOR MOTOR RELAY INPUT SIGNAL CIRCUIT FOR OPEN AND SHORT

1. Check the continuity between VVEL actuator motor relay harness connector and VVEL control module harness connector.

| VVEL control module |           |          | VVEL actuator motor relay |          | Continuity |
|---------------------|-----------|----------|---------------------------|----------|------------|
| Bank                | Connector | Terminal | Connector                 | Terminal |            |
| 1                   | E15       | 13       | E16                       | 3        | Existed    |
| 2                   |           | 1        |                           |          |            |

2. Also check harness for short to ground and power.

Is the inspection result normal?

YES >> GO TO 5.

NO >> Repair open circuit, short to ground or short to power in harness or connectors.

## 5.CHECK VVEL ACTUATOR MOTOR RELAY

Refer to [EC-1884, "Component Inspection \(VVEL Actuator Motor Relay\)"](#).

Is the inspection result normal?

YES >> GO TO 6.

NO >> Replace VVEL actuator motor relay.

## 6.CHECK ABORT CIRCUIT FOR OPEN AND SHORT

1. Disconnect ECM harness connector.
2. Check the continuity between VVEL control module harness connector and ECM harness connector.

| VVEL control module |          | ECM       |          | Continuity |
|---------------------|----------|-----------|----------|------------|
| Connector           | Terminal | Connector | Terminal |            |
| E15                 | 21       | M160      | 122      | Existed    |

3. Also check harness for short to ground and power.

Is the inspection result normal?

YES >> GO TO 8.

NO >> GO TO 7.

## 7.DETECT MALFUNCTIONING PART

Check the following.

- Harness for open and short between ECM and VVEL control module
- Loose or poor connection for each connector and harness

>> Repair open circuit, short to ground or short to power in harness or connectors.

## 8.CHECK INTERMITTENT INCIDENT

Refer to [GI-44, "Intermittent Incident"](#).

# P1091 VVEL ACTUATOR MOTOR RELAY

< DTC/CIRCUIT DIAGNOSIS >

[VK56VD FOR MEXICO]

Is the inspection result normal?

- YES >> GO TO 9.
- NO >> Repair or replace.

## 9. REPLACE VVEL CONTROL MODULE

Replace VVEL control module. Refer to [EC-2014, "Removal and Installation"](#).

>> GO TO 10.

## 10. PERFORM DTC CONFIRMATION PROCEDURE

1. Turn ignition switch ON.
2. Erase DTC.
3. Perform DTC Confirmation Procedure.  
See [EC-1882, "DTC Logic"](#).

Is the DTC P1091 displayed again?

- YES >> GO TO 11.
- NO >> INSPECTION END

## 11. REPLACE ECM

Replace ECM. Refer to [EC-2013, "Removal and Installation"](#).

>> INSPECTION END

## Component Inspection (VVEL Actuator Motor Relay)

INFOID:000000007758430

### 1. CHECK VVEL ACTUATOR MOTOR RELAY

1. Turn ignition switch OFF.
2. Remove VVEL actuator motor relay.
3. Check the continuity between VVEL actuator motor relay terminals under the following conditions.

| Terminal | Condition   | Continuity  |
|----------|---|-------------|
| 3 and 5  | 12V direct current supply between terminals 1 and 2 | Existed     |
|          | No current supply                                   | Not existed |

Is the inspection result normal?

- YES >> INSPECTION END
- NO >> Replace VVEL actuator motor relay.

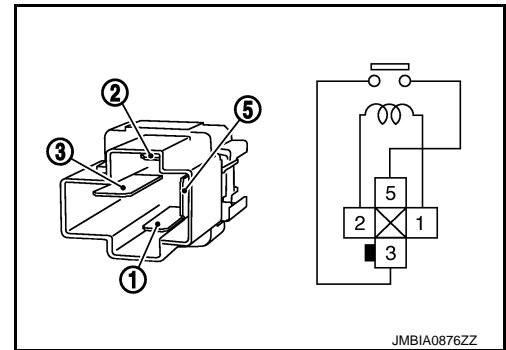

P1197 OUT OF GAS

Description

INFOID:000000007758433

This diagnosis result is detected when the fuel level of the fuel tank is extremely low and the engine does not run normally.

DTC Logic

INFOID:000000007758434

DTC DETECTION LOGIC

| DTC No. | Trouble diagnosis name<br>(Trouble diagnosis content) | DTC detecting condition   | Possible cause  |
|---------|---|---|---|
| P1197   | FUEL RUN OUT<br>(Out of gas)                          | <ul style="list-style-type: none"> <li>Fuel rail pressure remains at 1.5 MPa (15 bar, 15.3 kg/cm<sup>2</sup>, 217.5 psi) or less for 3 seconds or more with the fuel level too low.</li> <li>Fuel rail pressure remains 2.7 MPa (27 bar, 27.5 kg/cm<sup>2</sup>, 392 psi) lower than a target fuel pressure for 5 seconds or more with the fuel level too low.</li> <li>Fuel rail pressure remains at 0.23 MPa (2.3 bar, 2.346 kg/cm<sup>2</sup>, 33.35 psi) or less for 5 seconds or more with the fuel level too low.</li> </ul> <p><b>NOTE:</b><br/>Allow engine coolant temperature to reach 70°C (158°F) or more once.</p> | <ul style="list-style-type: none"> <li>Out of gas</li> <li>Harness or connectors (The low pressure fuel pump circuit is open or shorted.)</li> <li>Low pressure fuel pump</li> <li>Fuel pressure regulator</li> <li>Low pressure fuel system</li> <li>Low fuel pressure sensor</li> <li>Harness or connectors (The high pressure fuel pump circuit is shorted.)</li> <li>High pressure fuel pump</li> <li>High pressure fuel system</li> <li>Fuel rail pressure sensor</li> <li>Disconnection of the fuel hose</li> </ul> |

DTC CONFIRMATION PROCEDURE

1. PRECONDITIONING

- Turn ignition switch OFF and wait at least 10 seconds.
- Turn ignition switch ON.
- Turn ignition switch OFF and wait at least 10 seconds.

**TESTING CONDITION:**

Before performing the following procedure, confirm that battery voltage is 11 V or more at idle.

>> GO TO 2.

2. PERFORM DTC CONFIRMATION PROCEDURE-I

Start the engine.

Does the engine start?

- YES >> GO TO 3.
- NO >> Proceed to [EC-1886, "Diagnosis Procedure"](#).

3. PERFORM DTC CONFIRMATION PROCEDURE-II

- Warm up the engine to the normal operating temperature.
 

**NOTE:**  
For best results, warm up the engine until "COOLAN TEMP/S" on "DATA MONITOR" of CONSULT reaches at least 70°C (158°F).
- Keep the engine speed at 3,500 rpm for 5 seconds and let it idle at least 60 seconds..
- Check the 1st trip DTC.

**NOTE:**  
If the fuel tank has sufficient fuel, this diagnosis result may not be detected.

Is 1st trip DTC detected?

- YES >> Proceed to [EC-1886, "Diagnosis Procedure"](#).
- NO >> INSPECTION END

---

**Diagnosis Procedure****1. REFUEL THE VEHICLE**

---

1. Refuel 10 liter (10 US qt, 8 imp qt).

**CAUTION:****Never refuel more than 10 liter.**

2. Start the engine and keep the engine speed at 3,000 rpm for 30 seconds.

**NOTE:**

For best results, warm up the engine until "COOLAN TEMP/S" on "DATA MONITOR" of CONSULT reaches at least 70°C (158°F).

3. Turn ignition switch OFF and wait at least 10 seconds.
4. Turn ignition switch ON.
5. Turn ignition switch OFF and wait at least 10 seconds.
6. Turn ignition switch ON.
7. Erase the DTC.
8. Start the engine and let it idle at least 60 seconds.
9. Perform the confirmation procedure again. Refer to [EC-1885, "DTC Logic"](#).

Is 1st trip DTC detected?

YES &gt;&gt; GO TO 2.

NO &gt;&gt; INSPECTION END

**2. CHECK LOW PRESSURE FUEL PUMP**

---

Refer to [EC-1989, "Component Function Check"](#).Is inspection result normal?

YES &gt;&gt; GO TO 3.

NO &gt;&gt; Repair or replace error-detected parts.

**3. CHECK HIGH PRESSURE FUEL PUMP**

---

Refer to [EC-1979, "Component Function Check"](#).Is inspection result normal?

YES &gt;&gt; Check the fuel hose for disconnection and looseness.

NO &gt;&gt; Repair or replace error-detected parts.

# P1212 TCS COMMUNICATION LINE

< DTC/CIRCUIT DIAGNOSIS >

[VK56VD FOR MEXICO]

## P1212 TCS COMMUNICATION LINE

### Description

INFOID:000000007758439

This CAN communication line is used to control the smooth engine operation during the TCS operation. Pulse signals are exchanged between ECM and "ABS actuator and electric unit (control unit)".

**Be sure to erase the malfunction information such as DTC not only for "ABS actuator and electric unit (control unit)" but also for ECM after TCS related repair.**

### DTC Logic

INFOID:000000007758440

### DTC DETECTION LOGIC

#### NOTE:

- If DTC P1212 is displayed with DTC UXXXX, perform the trouble diagnosis for DTC UXXXX.
  - If DTC P1212 is displayed with DTC P0607, perform the trouble diagnosis for DTC P0607.
- Freeze frame data is not stored in the ECM for this self-diagnosis.

| DTC No. | Trouble diagnosis name<br>(Trouble diagnosis content) | DTC detecting condition   | Possible cause   |
|---------|---|---|--|
| P1212   | TCS/CIRC<br>(TCS communication line)                  | ECM cannot receive the information from "ABS actuator and electric unit (control unit)" continuously. | <ul style="list-style-type: none"><li>• Harness or connectors<br/>(The CAN communication line is open or shorted.)</li><li>• ABS actuator and electric unit (control unit)</li><li>• Dead (Weak) battery</li></ul> |

### DTC CONFIRMATION PROCEDURE

#### 1. PRECONDITIONING

1. Turn ignition switch OFF and wait at least 10 seconds.
2. Turn ignition switch ON.
3. Turn ignition switch OFF and wait at least 10 seconds.

#### TESTING CONDITION:

Before performing the following procedure, confirm that battery voltage is 10.5 V or more at idle.

>> GO TO 2.

#### 2. PERFORM DTC CONFIRMATION PROCEDURE

1. Start engine and let it idle for at least 10 seconds.
2. Check 1st trip DTC.

#### Is 1st trip DTC detected?

YES >> Proceed to [EC-1887, "Diagnosis Procedure"](#).

NO >> INSPECTION END

### Diagnosis Procedure

INFOID:000000007758441

Perform the trouble diagnosis for TCS. Refer to [BRC-55, "Work Flow"](#).

#### NOTE:

If DTC P1212 is displayed with DTC UXXXX and/or P0607, perform the following trouble diagnosis.

- Trouble diagnosis for DTC UXXXX Refer to [EC-1651, "DTC Index"](#).
- Trouble diagnosis for DTC P0607 Refer to [EC-1860, "DTC Logic"](#).

# P1217 ENGINE OVER TEMPERATURE

< DTC/CIRCUIT DIAGNOSIS >

[VK56VD FOR MEXICO]

## P1217 ENGINE OVER TEMPERATURE

### DTC Logic

INFOID:000000007758442

#### DTC DETECTION LOGIC

##### NOTE:

- If DTC P1217 is displayed with DTC UXXXX, first perform the trouble diagnosis for DTC UXXXX.
- If DTC P1217 is displayed with DTC P0607, first perform the trouble diagnosis for DTC P0607. Refer to [EC-1860, "DTC Logic"](#).

If the cooling fan or another component in the cooling system malfunctions, engine coolant temperature will rise.

When the engine coolant temperature reaches an abnormally high temperature condition, a malfunction is indicated.

| DTC No. | Trouble diagnosis name<br>(Trouble diagnosis content)    | DTC detecting condition  | Possible cause  |
|---------|--|--|---|
| P1217   | ENG OVER TEMP<br>[Engine over temperature<br>(Overheat)] | <ul style="list-style-type: none"><li>• Cooling fan does not operate properly (Overheat).</li><li>• Cooling fan system does not operate properly (Overheat).</li><li>• Engine coolant was not added to the system using the proper filling method.</li><li>• Engine coolant is not within the specified range.</li></ul> | <ul style="list-style-type: none"><li>• Harness or connectors<br/>(The cooling fan circuit is open or shorted.)</li><li>• IPDM E/R</li><li>• Cooling fan control module</li><li>• Cooling fan motor</li><li>• Radiator hose</li><li>• Radiator</li><li>• Radiator cap</li><li>• Water pump</li><li>• Thermostat</li></ul> |

##### CAUTION:

When a malfunction is indicated, always replace the coolant. Refer to [CO-34, "Draining"](#) and [CO-35, "Refilling"](#). Also, replace the engine oil. Refer to [LU-24, "Draining"](#) and [LU-25, "Refilling"](#).

1. Fill radiator with coolant up to specified level with a filling speed of 2 liters per minute. Always use coolant with the proper mixture ratio. Refer to [MA-17, "FOR NORTH AMERICA : Anti-Freeze Coolant Mixture Ratio"](#).
2. After refilling coolant, run engine to ensure that no water-flow noise is emitted.

#### DTC CONFIRMATION PROCEDURE

##### 1. PERFORM COMPONENT FUNCTION CHECK

Perform component function check. Refer to [EC-1888, "Component Function Check"](#).

##### NOTE:

Use component function check to check the overall function of the cooling fan. During this check, a DTC might not be confirmed.

Is the inspection result normal?

YES >> INSPECTION END

NO >> Proceed to [EC-1889, "Diagnosis Procedure"](#).

#### Component Function Check

INFOID:000000007758443

##### 1. PERFORM COMPONENT FUNCTION CHECK-I

##### WARNING:

Never remove the radiator cap when the engine is hot. Serious burns could be caused by high pressure fluid escaping from the radiator.

Wrap a thick cloth around cap. Carefully remove the cap by turning it a quarter turn to allow built-up pressure to escape. Then turn the cap all the way off.



# P1217 ENGINE OVER TEMPERATURE

[VK56VD FOR MEXICO]

## < DTC/CIRCUIT DIAGNOSIS >

Check the coolant level in the reservoir tank and radiator.

**Allow engine to cool before checking coolant level.**

Is the coolant level in the reservoir tank and/or radiator below the proper range?

- YES >> Proceed to [EC-1889, "Diagnosis Procedure"](#).  
NO >> GO TO 2.

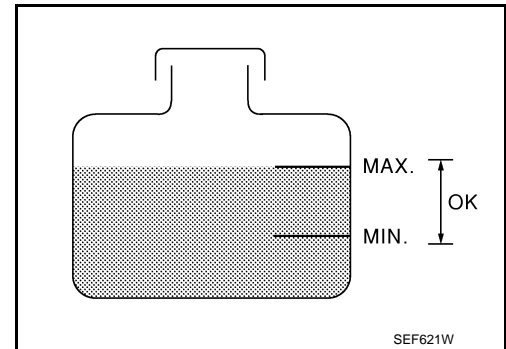

## 2.PERFORM COMPONENT FUNCTION CHECK-II

Confirm whether customer filled the coolant or not.

Did customer fill the coolant?

- YES >> Proceed to [EC-1889, "Diagnosis Procedure"](#).  
NO >> GO TO 3.

## 3.PERFORM COMPONENT FUNCTION CHECK-III

WITH CONSULT

1. Turn ignition switch ON.
2. Perform "FAN DUTY CONTROL" in "ACTIVE TEST" mode with CONSULT.
3. Check that cooling fan speed varies according to the percentage.

WITHOUT CONSULT

Perform IPDM E/R auto active test and check cooling fan motors operation, refer to [PCS-12, "Diagnosis Description"](#).

Is the inspection result normal?

- YES >> INSPECTION END  
NO >> Proceed to [EC-1889, "Diagnosis Procedure"](#).

## Diagnosis Procedure

INFOID:000000007758444

## 1.CHECK COOLING FAN OPERATION

WITH CONSULT

1. Turn ignition switch ON.
2. Perform "FAN DUTY CONTROL" in "ACTIVE TEST" mode with CONSULT.
3. Check that cooling fan speed varies according to the percentage.

WITHOUT CONSULT

1. Perform IPDM E/R auto active test and check cooling fan motors operation, refer to [PCS-12, "Diagnosis Description"](#).
2. Check that cooling fan operates.

Is the inspection result normal?

- YES >> GO TO 2.  
NO >> Proceed to [EC-1966, "Diagnosis Procedure"](#).

## 2.CHECK COOLING SYSTEM FOR LEAKAGE-I

Check cooling system for leakage. Refer to [CO-34, "Inspection"](#).

Is leakage detected?

- YES >> GO TO 3.  
NO >> GO TO 4.

## 3.CHECK COOLING SYSTEM FOR LEAKAGE-II

Check the following for leakage.

- Hose
- Radiator
- Water pump

## P1217 ENGINE OVER TEMPERATURE

< DTC/CIRCUIT DIAGNOSIS >

[VK56VD FOR MEXICO]

---

>> Repair or replace malfunctioning part.

### 4.CHECK RADIATOR CAP

---

Check radiator cap. Refer to [CO-38, "RADIATOR CAP : Inspection"](#).

Is the inspection result normal?

YES >> GO TO 5.

NO >> Replace radiator cap.

### 5.CHECK THERMOSTAT

---

Check thermostat. Refer to [CO-49, "Inspection"](#).

Is the inspection result normal?

YES >> GO TO 6.

NO >> Replace thermostat. Refer to [CO-48, "Removal and Installation"](#).

### 6.CHECK ENGINE COOLANT TEMPERATURE SENSOR

---

Refer to [EC-1763, "Component Inspection \(Engine Coolant Temperature Sensor\)"](#).

Is the inspection result normal?

YES >> GO TO 7.

NO >> Replace engine coolant temperature sensor. Refer to [EM-264, "Exploded View"](#).

### 7.OVERHEATING CAUSE ANALYSIS

---

If the cause cannot be isolated, check the [CO-32, "Troubleshooting Chart"](#).

>> INSPECTION END

P1225, P1234 TP SENSOR

DTC Logic

INFOID:000000007758448

DTC DETECTION LOGIC

| DTC No. | Trouble diagnosis name<br>(Trouble diagnosis content)                       | DTC detecting condition                                     | Possible cause   |
|---------|---|---|--|
| P1225   | CTP LEARNING-B1<br>[Closed throttle position learning performance (bank 1)] | Closed throttle position learning value is excessively low. | <ul style="list-style-type: none"> <li>Electric throttle control actuator (TP sensor 1 and 2)</li> </ul> |
| P1234   | CTP LEARNING-B2<br>[Closed throttle position learning performance (bank 2)] |   |  |

DTC CONFIRMATION PROCEDURE

1. PRECONDITIONING

- Turn ignition switch OFF and wait at least 10 seconds.
- Turn ignition switch ON.
- Turn ignition switch OFF and wait at least 10 seconds.

**TESTING CONDITION:**

Before performing the following procedure, confirm that battery voltage is 10 V or more at idle.

>> GO TO 2.

2. PERFORM DTC CONFIRMATION PROCEDURE

- Turn ignition switch ON.
- Turn ignition switch OFF and wait at least 10 seconds.
- Turn ignition switch ON.
- Check 1st trip DTC.

Is 1st trip DTC detected?

- YES >> Proceed to [EC-1891, "Diagnosis Procedure"](#).
- NO >> INSPECTION END

Diagnosis Procedure

INFOID:000000007758449

1. CHECK ELECTRIC THROTTLE CONTROL ACTUATOR VISUALLY

- Turn ignition switch OFF.
- Remove the intake air duct.
- Check that no foreign matter is caught between the throttle valve and the housing.

Is the inspection result normal?

- YES >> GO TO 2.
- NO >> Remove the foreign matter and clean the electric throttle control actuator inside, and then perform throttle valve closed position leaning. Refer to [EC-1686, "Work Procedure"](#)

2. REPLACE ELECTRIC THROTTLE CONTROL ACTUATOR

Replace malfunctioning electric throttle control actuator. Refer to [EM-191, "Removal and Installation"](#).

>> INSPECTION END

# P1226, P1235 TP SENSOR

< DTC/CIRCUIT DIAGNOSIS >

[VK56VD FOR MEXICO]

## P1226, P1235 TP SENSOR

### DTC Logic

INFOID:000000007758450

### DTC DETECTION LOGIC

| DTC No. | Trouble diagnosis name<br>(Trouble diagnosis content)                       | DTC detecting condition  | Possible cause   |
|---------|---|--|--|
| P1226   | CTP LEARNING-B1<br>[Closed throttle position learning performance (bank 1)] | Closed throttle position learning is not performed successfully, repeatedly. | • Electric throttle control actuator (TP sensor 1 and 2) |
| P1235   | CTP LEARNING-B2<br>[Closed throttle position learning performance (bank 2)] |  |  |

### DTC CONFIRMATION PROCEDURE

#### 1. PRECONDITIONING

1. Turn ignition switch OFF and wait at least 10 seconds.
2. Turn ignition switch ON.
3. Turn ignition switch OFF and wait at least 10 seconds.

#### TESTING CONDITION:

Before performing the following procedure, confirm that battery voltage is 10 V or more at idle.

>> GO TO 2.

#### 2. PERFORM DTC CONFIRMATION PROCEDURE

1. Turn ignition switch ON.
2. Turn ignition switch OFF and wait at least 10 seconds.
3. Turn ignition switch ON.
4. Repeat steps 2 and 3 for 32 times.
5. Check 1st trip DTC.

Is 1st trip DTC detected?

- YES >> Proceed to [EC-1892, "Diagnosis Procedure"](#).  
NO >> INSPECTION END

### Diagnosis Procedure

INFOID:000000007758451

#### 1. CHECK ELECTRIC THROTTLE CONTROL ACTUATOR VISUALLY

1. Turn ignition switch OFF.
2. Remove the intake air duct.
3. Check that no foreign matter is caught between the throttle valve and the housing.

Is the inspection result normal?

- YES >> GO TO 2.  
NO >> Remove the foreign matter and clean the electric throttle control actuator inside, and then perform throttle valve closed position learning. Refer to [EC-1686, "Work Procedure"](#).

#### 2. REPLACE ELECTRIC THROTTLE CONTROL ACTUATOR

Replace malfunctioning electric throttle control actuator. Refer to [EM-191, "Removal and Installation"](#).

>> INSPECTION END

# P1233, P2101 ELECTRIC THROTTLE CONTROL FUNCTION

< DTC/CIRCUIT DIAGNOSIS >

[VK56VD FOR MEXICO]

## P1233, P2101 ELECTRIC THROTTLE CONTROL FUNCTION

### DTC Logic

INFOID:000000007758452

#### DTC DETECTION LOGIC

##### NOTE:

If DTC P1233 or P2101 is displayed with DTC P1238, P2119, perform the trouble diagnosis for DTC P1238, P2119. Refer to [EC-1899, "DTC Logic"](#).

If DTC P1233 or P2101 is displayed with DTC P2100, perform the trouble diagnosis for DTC P1290, P2100. Refer to [EC-1948, "DTC Logic"](#).

| DTC No. | Trouble diagnosis name<br>(Trouble diagnosis content)                 | DTC detecting condition                                       | Possible cause  |
|---------|---|---|---|
| P1233   | ETC FNCTN/CIRC-B2<br>[Electric throttle control performance (bank 2)] | Electric throttle control function does not operate properly. | <ul style="list-style-type: none"> <li>Harness or connectors (Throttle control motor circuit is open or shorted)</li> <li>Electric throttle control actuator</li> </ul> |
| P2101   | ETC FNCTN/CIRC-B1<br>[Electric throttle control performance (bank 1)] |   |   |

#### DTC CONFIRMATION PROCEDURE

##### 1. PRECONDITIONING

- Turn ignition switch OFF and wait at least 10 seconds.
- Turn ignition switch ON.
- Turn ignition switch OFF and wait at least 10 seconds.

##### TESTING CONDITION:

Before performing the following procedure, confirm that battery voltage is 11 V or more when engine is running.

>> GO TO 2.

##### 2. PERFORM DTC CONFIRMATION PROCEDURE

- Turn ignition switch ON and wait at least 2 seconds.
- Start engine and let it idle for 5 seconds.
- Check DTC.

Is DTC detected?

- YES >> Proceed to [EC-1893, "Diagnosis Procedure"](#).  
 NO >> INSPECTION END

#### Diagnosis Procedure

INFOID:000000007758453

##### 1. CHECK THROTTLE CONTROL MOTOR RELAY INPUT SIGNAL CIRCUIT-I

Check the voltage between ECM harness connector terminals as per the following.

| DTC   | ECM       |          |           |          | Condition           | Voltage (V)     |
|-------|-----------|----------|-----------|----------|---------------------|-----------------|
|       | +         |          | -         |          |                     |                 |
|       | Connector | Terminal | Connector | Terminal |                     |                 |
| P1233 | M160      | 173      | M160      | 175      | Ignition switch OFF | Approx. 0       |
| P2101 |           |          |           |          | Ignition switch ON  | Battery voltage |

Is the inspection result normal?

- YES >> GO TO 8.  
 NO >> GO TO 2.

##### 2. CHECK THROTTLE CONTROL MOTOR RELAY POWER SUPPLY CIRCUIT

- Turn ignition switch OFF.

# P1233, P2101 ELECTRIC THROTTLE CONTROL FUNCTION

< DTC/CIRCUIT DIAGNOSIS >

[VK56VD FOR MEXICO]

2. Disconnect ECM harness connector.
3. Disconnect IPDM E/R harness connector E5.
4. Check the continuity between IPDM E/R harness connector and ECM harness connector.

| IPDM E/R  |          | ECM       |          | Continuity |
|-----------|----------|-----------|----------|------------|
| Connector | Terminal | Connector | Terminal |            |
| E5        | 7        | M160      | 173      | Existed    |

5. Also check harness for short to ground and short to power.

Is the inspection result normal?

YES >> GO TO 4.

NO >> GO TO 3.

## 3. DETECT MALFUNCTIONING PART

Check the following.

- Harness for open or short between ECM and IPDM E/R
- Loose or poor connection for each connector and harness

>> Repair open circuit, short to ground or short to power in harness or connectors.

## 4. CHECK THROTTLE CONTROL MOTOR RELAY INPUT SIGNAL CIRCUIT-II

1. Check the continuity between IPDM E/R harness connector and ECM harness connector.

| DTC            | IPDM E/R  |          | ECM       |          | Continuity |
|----------------|-----------|----------|-----------|----------|------------|
|                | Connector | Terminal | Connector | Terminal |            |
| P1233<br>P2101 | E7        | 71       | M160      | 123      | Existed    |

2. Also check harness for short to ground and short to power.

Is the inspection result normal?

YES >> GO TO 6.

NO >> GO TO 5.

## 5. DETECT MALFUNCTIONING PART

Check the following.

- Harness for open or short between ECM and IPDM E/R
- Loose or poor connection for each connector and harness

>> Repair open circuit, short to ground or short to power in harness or connectors.

## 6. CHECK FUSE

1. Disconnect 15 A fuse (No. 50) from IPDM E/R.
2. Check if 15 A fuse is blown.

Is the inspection result normal?

YES >> GO TO 7.

NO >> Replace 15 A fuse.

## 7. CHECK INTERMITTENT INCIDENT

Refer to [GI-44, "Intermittent Incident"](#).

Is the inspection result normal?

YES >> Replace IPDM E/R. Refer to [PCS-33, "Removal and Installation"](#).

NO >> Repair or replace harness or connectors.

## 8. CHECK THROTTLE CONTROL MOTOR OUTPUT SIGNAL CIRCUIT FOR OPEN OR SHORT

1. Turn ignition switch OFF.
2. Disconnect electric throttle control actuator harness connector.
3. Disconnect ECM harness connector.

# P1233, P2101 ELECTRIC THROTTLE CONTROL FUNCTION

< DTC/CIRCUIT DIAGNOSIS >

[VK56VD FOR MEXICO]

4. Check the continuity between electric throttle control actuator harness connector and ECM harness connector.

| DTC   | Electric throttle control actuator |           |          | ECM       |             | Continuity  |
|-------|------------------------------------|-----------|----------|-----------|-------------|-------------|
|       | Bank                               | Connector | Terminal | Connector | Terminal    |             |
| P1233 | 2                                  | F64       | 5        | F111      | 62          | Not existed |
|       |                                    |           | 6        |           | 58          | Existed     |
|       |                                    |           |          |           | 62          | Existed     |
|       |                                    |           | 58       |           | Not existed |             |
| P2101 | 1                                  | F66       | 5        | F111      | 57          | Not existed |
|       |                                    |           | 6        |           | 63          | Existed     |
|       |                                    |           |          |           | 57          | Existed     |
|       |                                    |           | 63       |           | Not existed |             |

5. Also check harness for short to ground and short to power.

Is the inspection result normal?

YES >> GO TO 9.

NO >> Repair or replace malfunctioning part.

## 9. CHECK ELECTRIC THROTTLE CONTROL ACTUATOR VISUALLY

- Remove the intake air duct. Refer to [EM-184, "Removal and Installation"](#).
- Check that no foreign matter is caught between the throttle valve and the housing.

Is the inspection result normal?

YES >> GO TO 10.

NO >> Remove the foreign matter and clean the electric throttle control actuator inside, and then perform throttle valve closed position learning. Refer to [EC-1686, "Work Procedure"](#).

## 10. CHECK THROTTLE CONTROL MOTOR

Refer to [EC-1895, "Component Inspection \(Electric Throttle Control Motor\)"](#).

Is the inspection result normal?

YES >> GO TO 11.

NO >> GO TO 12.

## 11. CHECK INTERMITTENT INCIDENT

Refer to [GI-44, "Intermittent Incident"](#).

Is the inspection result normal?

YES >> GO TO 12.

NO >> Repair or replace harness or connectors.

## 12. REPLACE ELECTRIC THROTTLE CONTROL ACTUATOR

Replace malfunction electric throttle control actuator. Refer to [EM-191, "Removal and Installation"](#).

>> INSPECTION END

## Component Inspection (Electric Throttle Control Motor)

INFOID:000000007758454

### 1. CHECK THROTTLE CONTROL MOTOR

- Turn ignition switch OFF.
- Disconnect electric throttle control actuator harness connector.
- Check resistance between electric throttle control actuator terminals as per the following.

# P1233, P2101 ELECTRIC THROTTLE CONTROL FUNCTION

[VK56VD FOR MEXICO]

< DTC/CIRCUIT DIAGNOSIS >

| Electric throttle control actuator |           |           | Resistance                               |
|------------------------------------|-----------|-----------|--|
| Bank                               | Connector | Terminals |  |
| 1                                  | F66       | 5 and 6   | Approx. 1 - 15 $\Omega$ [at 25°C (77°F)] |
| 2                                  | F64       | 5 and 6   |  |

Is the inspection result normal?

YES >> INSPECTION END

NO >> GO TO 2.

## 2. REPLACE ELECTRIC THROTTLE CONTROL ACTUATOR

Replace malfunctioning electric throttle control actuator. Refer to [EM-191, "Removal and Installation"](#).

>> INSPECTION END



# P1236, P2118 THROTTLE CONTROL MOTOR

< DTC/CIRCUIT DIAGNOSIS >

[VK56VD FOR MEXICO]

## P1236, P2118 THROTTLE CONTROL MOTOR

### DTC Logic

INFOID:000000007758455

### DTC DETECTION LOGIC

| DTC No. | Trouble diagnosis name<br>(Trouble diagnosis content)            | DTC detecting condition   | Possible cause  |
|---------|--|---|---|
| P1236   | ETC MOT-B2<br>[Throttle control motor (bank 2)<br>circuit short] | ECM detects short in both circuits between<br>ECM and throttle control motor. | <ul style="list-style-type: none"> <li>• Harness or connectors<br/>(Throttle control motor circuit is shorted.)</li> <li>• Electric throttle control actuator<br/>(Throttle control motor)</li> </ul> |
| P2118   | ETC MOT-B1<br>[Throttle control motor (bank 1)<br>circuit short] |   |   |

### DTC CONFIRMATION PROCEDURE

#### 1. PRECONDITIONING

If DTC Confirmation Procedure has been previously conducted, always perform the following procedure before conducting the next test.

1. Turn ignition switch OFF and wait at least 10 seconds.
2. Turn ignition switch ON.
3. Turn ignition switch OFF and wait at least 10 seconds.

>> GO TO 2.

#### 2. PERFORM DTC CONFIRMATION PROCEDURE

1. Turn ignition switch ON and wait at least 2 seconds.
2. Start engine and let it idle for 5 seconds.
3. Check DTC.

Is DTC detected?

- YES >> Proceed to [EC-1897, "Diagnosis Procedure"](#).  
 NO >> INSPECTION END

### Diagnosis Procedure

INFOID:000000007758456

#### 1. CHECK THROTTLE CONTROL MOTOR OUTPUT SIGNAL CIRCUIT FOR OPEN AND SHORT

1. Disconnect electric throttle control actuator harness connector.
2. Disconnect ECM harness connector.
3. Check the continuity between electric throttle control actuator harness connector and ECM harness connector.

| DTC   | Electric throttle control actuator |           |          | ECM       |          | Continuity  |
|-------|------------------------------------|-----------|----------|-----------|----------|-------------|
|       | Bank                               | Connector | Terminal | Connector | Terminal |             |
| P1233 | 2                                  | F64       | 5        | F111      | 62       | Not existed |
|       |                                    |           |          |           | 58       | Existed     |
|       |                                    |           | 6        |           | 62       | Existed     |
|       |                                    |           |          |           | 58       | Not existed |
| P2101 | 1                                  | F66       | 5        | F111      | 57       | Not existed |
|       |                                    |           |          |           | 63       | Existed     |
|       |                                    |           | 6        |           | 57       | Existed     |
|       |                                    |           |          |           | 63       | Not existed |

4. Also check harness for short to ground and short to power.

Is the inspection result normal?

# P1236, P2118 THROTTLE CONTROL MOTOR

< DTC/CIRCUIT DIAGNOSIS >

[VK56VD FOR MEXICO]

- YES >> GO TO 2.  
NO >> Repair or replace malfunctioning part.

## 2.CHECK THROTTLE CONTROL MOTOR

Refer to [EC-1895, "Component Inspection \(Electric Throttle Control Motor\)"](#).

Is the inspection result normal?

- YES >> GO TO 3.  
NO >> GO TO 4.

## 3.CHECK INTERMITTENT INCIDENT

Refer to [GI-44, "Intermittent Incident"](#).

Is the inspection result normal?

- YES >> GO TO 4.  
NO >> Repair or replace harness or connectors.

## 4.REPLACE ELECTRIC THROTTLE CONTROL ACTUATOR

Replace malfunctioning electric throttle control actuator. Refer to [EM-191, "Removal and Installation"](#).

>> INSPECTION END

## Component Inspection (Electric Throttle Control Motor)

INFOID:000000007758457

## 1.CHECK THROTTLE CONTROL MOTOR

1. Turn ignition switch OFF.
2. Disconnect electric throttle control actuator harness connector.
3. Check resistance between electric throttle control actuator terminals as per the following.

| Electric throttle control actuator |           |           | Resistance                               |
|------------------------------------|-----------|-----------|--|
| Bank                               | Connector | Terminals |  |
| 1                                  | F66       | 5 and 6   | Approx. 1 - 15 $\Omega$ [at 25°C (77°F)] |
| 2                                  | F64       | 5 and 6   |  |

Is the inspection result normal?

- YES >> INSPECTION END  
NO >> GO TO 2.

## 2.REPLACE ELECTRIC THROTTLE CONTROL ACTUATOR

Replace malfunctioning electric throttle control actuator. Refer to [EM-191, "Removal and Installation"](#).

>> INSPECTION END

# P1238, P2119 ELECTRIC THROTTLE CONTROL ACTUATOR

< DTC/CIRCUIT DIAGNOSIS >

[VK56VD FOR MEXICO]

## P1238, P2119 ELECTRIC THROTTLE CONTROL ACTUATOR

### DTC Logic

INFOID:000000007758458

### DTC DETECTION LOGIC

| DTC No. | Trouble diagnosis name<br>(Trouble diagnosis content)        | DTC detecting condition |   | Possible cause                     |
|---------|--|-------------------------|---|------------------------------------|
| P1238   | ETC ACTR-B2<br>[Electric throttle control actuator (bank 2)] | A)                      | Electric throttle control actuator does not function properly due to the return spring malfunction. | Electric throttle control actuator |
|         |  | B)                      | Throttle valve opening angle in fail-safe mode is not in specified range.                           |                                    |
|         |  | C)                      | ECM detect that the throttle valve is stuck open.   |                                    |
| P2119   | ETC ACTR-B1<br>[Electric throttle control actuator (bank 1)] | A)                      | Electric throttle control actuator does not function properly due to the return spring malfunction. | Electric throttle control actuator |
|         |  | B)                      | Throttle valve opening angle in fail-safe mode is not in specified range.                           |                                    |
|         |  | C)                      | ECM detects that the throttle valve is stuck open.  |                                    |

### DTC CONFIRMATION PROCEDURE

#### 1. PRECONDITIONING

1. Turn ignition switch OFF and wait at least 10 seconds.
2. Turn ignition switch ON.
3. Turn ignition switch OFF and wait at least 10 seconds.

#### TESTING CONDITION:

Before performing the following procedure, confirm that battery voltage is 8 V or more at idle.

>> GO TO 2.

#### 2. PERFORM DTC CONFIRMATION PROCEDURE FOR MALFUNCTION A AND B

1. Turn ignition switch ON and wait at least 1 second.
2. Shift selector lever position to D and wait at least 3 seconds.
3. Shift selector lever position to P.
4. Turn ignition switch OFF and wait at least 10 seconds.
5. Turn ignition switch ON and wait at least 1 second.
6. Shift selector lever position to D and wait at least 3 seconds.
7. Shift selector lever position to P.
8. Turn ignition switch OFF, wait at least 10 seconds, and then turn ON.
9. Check DTC.

#### Is DTC detected?

- YES >> Proceed to [EC-1899, "Diagnosis Procedure"](#).  
NO >> GO TO 3.

#### 3. PERFORM DTC CONFIRMATION PROCEDURE FOR MALFUNCTION C

1. Turn ignition switch ON and wait at least 1 second.
2. Shift selector lever position to D and wait at least 3 seconds.
3. Shift selector lever position to P.
4. Start engine and let it idle for 3 seconds.
5. Check DTC.

#### Is DTC detected?

- YES >> Proceed to [EC-1899, "Diagnosis Procedure"](#).  
NO >> INSPECTION END

### Diagnosis Procedure

INFOID:000000007758459

#### 1. CHECK ELECTRIC THROTTLE CONTROL ACTUATOR VISUALLY

## P1238, P2119 ELECTRIC THROTTLE CONTROL ACTUATOR

[VK56VD FOR MEXICO]

< DTC/CIRCUIT DIAGNOSIS >

---

1. Turn ignition switch OFF.
2. Remove the intake air duct.
3. Check that no foreign matter is caught between the throttle valve and the housing.

Is the inspection result normal?

YES >> GO TO 2.

NO >> Remove the foreign matter and clean the electric throttle control actuator inside, and then perform throttle valve closed position leaning. Refer to [EC-1686, "Work Procedure"](#).

### **2. REPLACE ELECTRIC THROTTLE CONTROL ACTUATOR**

---

Replace malfunctioning electric throttle control actuator. Refer to [EM-191, "Removal and Installation"](#).

>> INSPECTION END

P1239, P2135 TP SENSOR

DTC Logic

INFOID:000000007758460

DTC DETECTION LOGIC

NOTE:

If DTC P1239 or P2135 is displayed with DTC P0643, first perform the trouble diagnosis for DTC P0643. Refer to [EC-1863, "DTC Logic"](#).

| DTC No. | Trouble diagnosis name (Trouble diagnosis content)                         | DTC detecting condition   | Possible cause   |
|---------|--|---|--|
| P1239   | TP SENSOR-B2 [Throttle position sensor (bank 2) circuit range/performance] | Rationally incorrect voltage is sent to ECM compared with the signals from TP sensor 1 and TP sensor 2. | <ul style="list-style-type: none"> <li>Harness or connector (Throttle position sensor 1 or 2 circuit is open or shorted.)</li> <li>Electric throttle control actuator (Throttle position sensor 1 or 2)</li> </ul> |
| P2135   | TP SENSOR-B1 [Throttle position sensor (bank 1) circuit range/performance] |   |  |

DTC CONFIRMATION PROCEDURE

1. PRECONDITIONING

- Turn ignition switch OFF and wait at least 10 seconds.
- Turn ignition switch ON.
- Turn ignition switch OFF and wait at least 10 seconds.

TESTING CONDITION:

Before performing the following procedure, confirm that battery voltage is 8 V or more at idle.

>> GO TO 2.

2. PERFORM DTC CONFIRMATION PROCEDURE

- Start engine and let it idle for 1 second.
- Check DTC.

Is DTC detected?

- YES >> Proceed to [EC-1901, "Diagnosis Procedure"](#).  
 NO >> INSPECTION END

Diagnosis Procedure

INFOID:000000007758461

1. CHECK THROTTLE POSITION SENSOR POWER SUPPLY CIRCUIT-I

- Disconnect electric throttle control actuator harness connector.
- Turn ignition switch ON.
- Check the voltage between electric throttle control actuator harness connector and ground.

| DTC   | Electric throttle control actuator |           |          | Ground | Voltage (V) |
|-------|------------------------------------|-----------|----------|--------|-------------|
|       | Bank                               | Connector | Terminal |        |             |
| P1239 | 2                                  | F64       | 2        | Ground | Approx. 5   |
| P2135 | 1                                  | F66       | 2        |        |             |

Is the inspection result normal?

- YES >> GO TO 2.  
 NO >> Repair open circuit, short to ground or short to power in harness or connectors.

2. CHECK THROTTLE POSITION SENSOR GROUND CIRCUIT FOR OPEN AND SHORT

- Turn ignition switch OFF.
- Disconnect ECM harness connector.

# P1239, P2135 TP SENSOR

[VK56VD FOR MEXICO]

## < DTC/CIRCUIT DIAGNOSIS >

3. Check the continuity between electric throttle control actuator harness connector and ECM harness connector.

| DTC   | Electric throttle control actuator |           |          | ECM       |          | Continuity |
|-------|------------------------------------|-----------|----------|-----------|----------|------------|
|       | Bank                               | Connector | Terminal | Connector | Terminal |            |
| P1239 | 2                                  | F64       | 4        | F111      | 69       | Existed    |
| P2135 | 1                                  | F66       | 4        |           | 97       |            |

4. Also check harness for short to ground and short to power.

Is the inspection result normal?

YES >> GO TO 3.

NO >> Repair open circuit, short to ground or short to power in harness or connectors.

## 3.CHECK THROTTLE POSITION SENSOR INPUT SIGNAL CIRCUIT FOR OPEN AND SHORT

1. Check the continuity between electric throttle control actuator harness connector and ECM harness connector.

| DTC   | Electric throttle control actuator |           |          | ECM       |          | Continuity |
|-------|------------------------------------|-----------|----------|-----------|----------|------------|
|       | Bank                               | Connector | Terminal | Connector | Terminal |            |
| P1239 | 2                                  | F64       | 1        | F111      | 71       | Existed    |
|       |                                    |           | 3        |           | 89       |            |
| P2135 | 1                                  | F66       | 1        |           | 91       |            |
|       |                                    |           | 3        |           | 79       |            |

2. Also check harness for short to ground and short to power.

Is the inspection result normal?

YES >> GO TO 4.

NO >> Repair open circuit, short to ground or short to power in harness or connectors.

## 4.CHECK THROTTLE POSITION SENSOR

Refer to [EC-1902, "Component Inspection \(Throttle Position Sensor\)"](#).

Is the inspection result normal?

YES >> GO TO 6.

NO >> GO TO 5.

## 5.REPLACE ELECTRIC THROTTLE CONTROL ACTUATOR

Replace malfunctioning electric throttle control actuator. Refer to [EM-191, "Removal and Installation"](#).

>> INSPECTION END

## 6.CHECK INTERMITTENT INCIDENT

Refer to [GI-44, "Intermittent Incident"](#).

>> INSPECTION END

## Component Inspection (Throttle Position Sensor)

INFOID:000000007758462

## 1.CHECK THROTTLE POSITION SENSOR

1. Turn ignition switch OFF.
2. Reconnect all harness connectors disconnected.
3. Perform [EC-1686, "Work Procedure"](#).
4. Turn ignition switch ON.
5. Set selector lever position to D.
6. Check the voltage between ECM harness connector terminals under the following conditions.

# P1239, P2135 TP SENSOR

< DTC/CIRCUIT DIAGNOSIS >

[VK56VD FOR MEXICO]

| ECM       |                              |          | Condition                          | Voltage (V)    |
|-----------|------------------------------|----------|------------------------------------|----------------|
| Connector | +                            | -        |                                    |                |
|           | Terminal                     | Terminal |                                    |                |
| F111      | 91<br>[TP sensor 1 (bank 1)] | 97       | Accelerator pedal: Fully released  | More than 0.36 |
|           |                              |          | Accelerator pedal: Fully depressed | Less than 4.75 |
|           | 71<br>[TP sensor 1 (bank 2)] | 69       | Accelerator pedal: Fully released  | More than 0.36 |
|           |                              |          | Accelerator pedal: Fully depressed | Less than 4.75 |
|           | 79<br>[TP sensor 2 (bank 1)] | 97       | Accelerator pedal: Fully released  | Less than 4.75 |
|           |                              |          | Accelerator pedal: Fully depressed | More than 0.36 |
|           | 89<br>[TP sensor 2 (bank 2)] | 69       | Accelerator pedal: Fully released  | Less than 4.75 |
|           |                              |          | Accelerator pedal: Fully depressed | More than 0.36 |

Is the inspection result normal?

YES >> INSPECTION END

NO >> GO TO 2.

## 2. REPLACE ELECTRIC THROTTLE CONTROL ACTUATOR

Replace malfunctioning electric throttle control actuator. Refer to [EM-191. "Removal and Installation"](#).

>> INSPECTION END

A  
EC  
C  
D  
E  
F  
G  
H  
I  
J  
K  
L  
M  
N  
O  
P

# P1550 BATTERY CURRENT SENSOR

< DTC/CIRCUIT DIAGNOSIS >

[VK56VD FOR MEXICO]

## P1550 BATTERY CURRENT SENSOR

### DTC Logic

INFOID:000000007758466

### DTC DETECTION LOGIC

| DTC No. | Trouble diagnosis name<br>(Trouble diagnosis content)                    | DTC detecting condition  | Possible cause  |
|---------|--|--|---|
| P1550   | BAT CURRENT SENSOR<br>(Battery current sensor circuit range/performance) | The output voltage of the battery current sensor remains within the specified range while engine is running. | <ul style="list-style-type: none"> <li>• Harness or connectors<br/>(Battery current sensor circuit is shorted.)<br/>(Crankshaft position sensor circuit is open or shorted.)<br/>[Camshaft position sensor (bank 1) circuit is shorted.]<br/>(Accelerator pedal position sensor 2 circuit is shorted.)<br/>(EVAP control system pressure sensor circuit is shorted.)<br/>(Refrigerant pressure sensor circuit is shorted.)</li> <li>• Battery current sensor</li> <li>• Crankshaft position sensor</li> <li>• Camshaft position sensor (bank 1)</li> <li>• Accelerator pedal position sensor 2</li> <li>• EVAP control system pressure sensor</li> <li>• Refrigerant pressure sensor</li> </ul> |

### DTC CONFIRMATION PROCEDURE

#### 1. PRECONDITIONING

1. Turn ignition switch OFF and wait at least 10 seconds.
2. Turn ignition switch ON.
3. Turn ignition switch OFF and wait at least 10 seconds.

#### TESTING CONDITION:

Before performing the following procedure, confirm that battery voltage is 8 V or more at idle.

>> GO TO 2.

#### 2. PERFORM DTC CONFIRMATION PROCEDURE

1. Start engine and let it idle for at least 10 seconds.
2. Check 1st trip DTC.

#### Is 1st trip DTC detected?

- YES >> Proceed to [EC-1904, "Diagnosis Procedure"](#).  
 NO >> INSPECTION END

### Diagnosis Procedure

INFOID:000000007758467

#### 1. CHECK BATTERY CURRENT SENSOR POWER SUPPLY CIRCUIT-I

1. Disconnect battery current sensor harness connector.
2. Turn ignition switch ON.
3. Check the voltage between battery current sensor harness connector and ground.

| Battery current sensor |          | Ground | Voltage (V) |
|------------------------|----------|--------|-------------|
| Connector              | Terminal |        |             |
| E21                    | 1        | Ground | Approx. 5   |

#### Is the inspection result normal?

- YES >> GO TO 7.  
 NO >> GO TO 2.

#### 2. CHECK BATTERY CURRENT SENSOR POWER SUPPLY CIRCUIT-II

1. Turn ignition switch ON.
2. Disconnect ECM harness connector.



# P1550 BATTERY CURRENT SENSOR

< DTC/CIRCUIT DIAGNOSIS >

[VK56VD FOR MEXICO]

3. Check the continuity between battery current sensor harness connector and ECM harness connector.

| Battery current sensor |          | ECM       |          | Continuity |
|------------------------|----------|-----------|----------|------------|
| Connector              | Terminal | Connector | Terminal |            |
| E21                    | 1        | M160      | 133      | Existed    |

Is the inspection result normal?

YES >> GO TO 3.

NO >> Repair open circuit.

## 3.CHECK SENSOR POWER SUPPLY CIRCUIT

Check harness for short to power and short to ground, between the following terminals.

| ECM       |          | Sensor                              |           |          |
|-----------|----------|-------------------------------------|-----------|----------|
| Connector | Terminal | Name                                | Connector | Terminal |
| F111      | 76       | CKP sensor                          | F2        | 1        |
|           | 77       | Camshaft position sensor (bank 1)   | F84       | 1        |
| M160      | 133      | Battery current sensor              | E21       | 1        |
|           | 133      | EVAP control system pressure sensor | B73       | 3        |
|           | 133      | Refrigerant pressure sensor         | E77       | 3        |
|           | 131      | APP sensor 2 (Without ICC)          | M9        | 6        |
|           | 131      | APP sensor 2 (With ICC)             | M153      | 3        |

Is the inspection result normal?

YES >> GO TO 4.

NO >> Repair short to ground or short to power in harness or connectors.

## 4.CHECK COMPONENTS

Check the following.

- Camshaft position sensor (bank 1) (Refer to [EC-1831, "Component Inspection \(Camshaft Position Sensor\)"](#).)
- CKP sensor (Refer to [EC-1826, "Component Inspection \(Crankshaft Position Sensor\)"](#).)
- EVAP control system pressure sensor (Refer to [EC-1974, "Component Inspection \(EVAP Control System Pressure Sensor\)"](#).)
- Refrigerant pressure sensor (Refer to [EC-2001, "Diagnosis Procedure"](#).)

Is the inspection result normal?

YES >> GO TO 5.

NO >> Replace malfunctioning component.

## 5.CHECK APP SENSOR

Refer to [EC-1960, "Component Inspection \(Accelerator Pedal Position Sensor\)"](#).

Is the inspection result normal?

YES >> GO TO 10.

NO >> GO TO 6.

## 6.REPLACE ACCELERATOR PEDAL ASSEMBLY

Replace accelerator pedal assembly. Refer to following.

- Models without Distance Control Assist system: [ACC-3, "MODELS WITHOUT DISTANCE CONTROL ASSIST SYSTEM : Removal and Installation"](#)
- Models with Distance Control Assist system: [ACC-4, "MODELS WITH DISTANCE CONTROL ASSIST SYSTEM : Removal and Installation"](#)

>> INSPECTION END

## 7.CHECK BATTERY CURRENT SENSOR GROUND CIRCUIT FOR OPEN AND SHORT

1. Turn ignition switch OFF.

# P1550 BATTERY CURRENT SENSOR

< DTC/CIRCUIT DIAGNOSIS >

[VK56VD FOR MEXICO]

2. Disconnect ECM harness connector.
3. Check the continuity between battery current sensor harness connector and ECM harness connector.

| Battery current sensor |          | ECM       |          | Continuity |
|------------------------|----------|-----------|----------|------------|
| Connector              | Terminal | Connector | Terminal |            |
| E21                    | 3        | M160      | 150      | Existed    |

4. Also check harness for short to ground and short to power.

Is the inspection result normal?

YES >> GO TO 8.

NO >> Repair open circuit, short to ground or short to power in harness or connectors.

## 8. CHECK BATTERY CURRENT SENSOR INPUT SIGNAL CIRCUIT FOR OPEN AND SHORT

1. Check the continuity between battery current sensor harness connector and ECM harness connector.

| Battery current sensor |          | ECM       |          | Continuity |
|------------------------|----------|-----------|----------|------------|
| Connector              | Terminal | Connector | Terminal |            |
| E21                    | 4        | M160      | 138      | Existed    |

2. Also check harness for short to ground and short to power.

Is the inspection result normal?

YES >> GO TO 9.

NO >> Repair open circuit, short to ground or short to power in harness or connectors.

## 9. CHECK BATTERY CURRENT SENSOR

Refer to [EC-1906. "Component Inspection \(Battery Current Sensor\)"](#).

Is the inspection result normal?

YES >> GO TO 10.

NO >> Replace battery negative cable assembly.

## 10. CHECK INTERMITTENT INCIDENT

Refer to [GI-44. "Intermittent Incident"](#).

>> INSPECTION END

## Component Inspection (Battery Current Sensor)

INFOID:000000007758468

### 1. CHECK BATTERY CURRENT SENSOR

1. Turn ignition switch OFF.
2. Reconnect harness connectors disconnected.
3. Disconnect battery negative cable.
4. Install jumper cable between battery negative terminal and body ground.
5. Turn ignition switch ON.
6. Check the voltage between ECM harness connector terminals under the following conditions.

| Connector | ECM                                    |          | Voltage (V) |
|-----------|--|----------|-------------|
|           | +                                      | -        |             |
|           | Terminal                               | Terminal |             |
| M160      | 138<br>(Battery current sensor signal) | 150      | Approx. 2.5 |

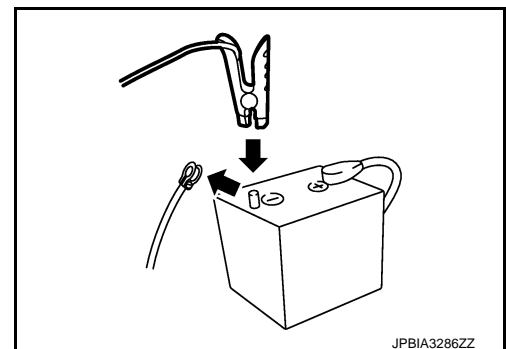

Before measuring the terminal voltage, confirm that the battery is fully charged. Refer to [PG-135. "How to Handle Battery"](#).

Is the inspection result normal?

YES >> INSPECTION END

# P1550 BATTERY CURRENT SENSOR

< DTC/CIRCUIT DIAGNOSIS >

[VK56VD FOR MEXICO]

NO >> Replace battery negative cable assembly.

A

**EC**

C

D

E

F

G

H

I

J

K

L

M

N

O

P

# P1551, P1552 BATTERY CURRENT SENSOR

< DTC/CIRCUIT DIAGNOSIS >

[VK56VD FOR MEXICO]

## P1551, P1552 BATTERY CURRENT SENSOR

### DTC Logic

INFOID:000000007758469

### DTC DETECTION LOGIC

| DTC No. | Trouble diagnosis name<br>(Trouble diagnosis content)             | DTC detecting condition                                     | Possible cause  |
|---------|---|---|---|
| P1551   | BAT CURRENT SENSOR<br>(Battery current sensor circuit low input)  | An excessively low voltage from the sensor is sent to ECM.  | <ul style="list-style-type: none"> <li>• Harness or connectors<br/>(Battery current sensor circuit is shorted.)<br/>(Crankshaft position sensor circuit is open or shorted.)<br/>[Camshaft position sensor (bank 1) circuit is shorted.]<br/>(Accelerator pedal position sensor 2 circuit is shorted.)<br/>(EVAP control system pressure sensor circuit is shorted.)<br/>(Refrigerant pressure sensor circuit is shorted.)</li> <li>• Battery current sensor</li> <li>• Crankshaft position sensor</li> <li>• Camshaft position sensor (bank 1)</li> <li>• Accelerator pedal position sensor 2</li> <li>• EVAP control system pressure sensor</li> <li>• Refrigerant pressure sensor</li> </ul> |
| P1552   | Battery current sensor circuit high input<br>(BAT CURRENT SENSOR) | An excessively high voltage from the sensor is sent to ECM. |   |

### DTC CONFIRMATION PROCEDURE

#### 1. PRECONDITIONING

1. Turn ignition switch OFF and wait at least 10 seconds.
2. Turn ignition switch ON.
3. Turn ignition switch OFF and wait at least 10 seconds.

#### TESTING CONDITION:

Before performing the following procedure, confirm that battery voltage is 8 V or more with ignition switch ON

>> GO TO 2.

#### 2. PERFORM DTC CONFIRMATION PROCEDURE

1. Turn ignition switch ON and wait at least 10 seconds.
2. Check 1st trip DTC.

#### Is 1st trip DTC detected?

- YES >> Proceed to [EC-1908, "Diagnosis Procedure"](#).  
NO >> INSPECTION END

### Diagnosis Procedure

INFOID:000000007758470

#### 1. CHECK BATTERY CURRENT SENSOR POWER SUPPLY CIRCUIT-I

1. Disconnect battery current sensor harness connector.
2. Turn ignition switch ON.
3. Check the voltage between battery current sensor harness connector and ground.

| Battery current sensor |          | Ground | Voltage (V) |
|------------------------|----------|--------|-------------|
| Connector              | Terminal |        |             |
| E21                    | 1        | Ground | Approx. 5   |

#### Is the inspection result normal?

- YES >> GO TO 7.  
NO >> GO TO 2.

# P1551, P1552 BATTERY CURRENT SENSOR

< DTC/CIRCUIT DIAGNOSIS >

[VK56VD FOR MEXICO]

## 2. CHECK BATTERY CURRENT SENSOR POWER SUPPLY CIRCUIT-II

1. Turn ignition switch ON.
2. Disconnect ECM harness connector.
3. Check the continuity between battery current sensor harness connector and ECM harness connector.

| Battery current sensor |          | ECM       |          | Continuity |
|------------------------|----------|-----------|----------|------------|
| Connector              | Terminal | Connector | Terminal |            |
| E21                    | 1        | M160      | 133      | Existed    |

Is the inspection result normal?

YES >> GO TO 3.

NO >> Repair open circuit.

## 3. CHECK SENSOR POWER SUPPLY CIRCUIT

Check harness for short to power and short to ground, between the following terminals.

| ECM       |          | Sensor                              |           |          |
|-----------|----------|-------------------------------------|-----------|----------|
| Connector | Terminal | Name                                | Connector | Terminal |
| F111      | 76       | CKP sensor                          | F2        | 1        |
|           | 77       | Camshaft position sensor (bank 1)   | F84       | 1        |
| M160      | 133      | Battery current sensor              | E21       | 1        |
|           | 133      | EVAP control system pressure sensor | B73       | 3        |
|           | 133      | Refrigerant pressure sensor         | E77       | 3        |
|           | 131      | APP sensor 2 (Without ICC)          | M9        | 6        |
|           | 131      | APP sensor 2 (With ICC)             | M153      | 3        |

Is the inspection result normal?

YES >> GO TO 4.

NO >> Repair short to ground or short to power in harness or connectors.

## 4. CHECK COMPONENTS

Check the following.

- Camshaft position sensor (bank 1) (Refer to [EC-1831, "Component Inspection \(Camshaft Position Sensor\)"](#).)
- CKP sensor (Refer to [EC-1826, "Component Inspection \(Crankshaft Position Sensor\)"](#).)
- EVAP control system pressure sensor (Refer to [EC-1974, "Component Inspection \(EVAP Control System Pressure Sensor\)"](#).)
- Refrigerant pressure sensor (Refer to [EC-2001, "Diagnosis Procedure"](#).)

Is the inspection result normal?

YES >> GO TO 5.

NO >> Replace malfunctioning component.

## 5. CHECK APP SENSOR

Refer to [EC-1960, "Component Inspection \(Accelerator Pedal Position Sensor\)"](#).

Is the inspection result normal?

YES >> GO TO 10.

NO >> GO TO 6.

## 6. REPLACE ACCELERATOR PEDAL ASSEMBLY

Replace accelerator pedal assembly. Refer to following.

- Models without Distance Control Assist system: [ACC-3, "MODELS WITHOUT DISTANCE CONTROL ASSIST SYSTEM : Removal and Installation"](#)
- Models with Distance Control Assist system: [ACC-4, "MODELS WITH DISTANCE CONTROL ASSIST SYSTEM : Removal and Installation"](#)

# P1551, P1552 BATTERY CURRENT SENSOR

< DTC/CIRCUIT DIAGNOSIS >

[VK56VD FOR MEXICO]

>> INSPECTION END

## 7. CHECK BATTERY CURRENT SENSOR GROUND CIRCUIT FOR OPEN AND SHORT

1. Turn ignition switch OFF.
2. Disconnect ECM harness connector.
3. Check the continuity between battery current sensor harness connector and ECM harness connector.

| Battery current sensor |          | ECM       |          | Continuity |
|------------------------|----------|-----------|----------|------------|
| Connector              | Terminal | Connector | Terminal |            |
| E21                    | 3        | M160      | 150      | Existed    |

4. Also check harness for short to ground and short to power.

Is the inspection result normal?

YES >> GO TO 8.

NO >> Repair open circuit, short to ground or short to power in harness or connectors.

## 8. CHECK BATTERY CURRENT SENSOR INPUT SIGNAL CIRCUIT FOR OPEN AND SHORT

1. Check the continuity between battery current sensor harness connector and ECM harness connector.

| Battery current sensor |          | ECM       |          | Continuity |
|------------------------|----------|-----------|----------|------------|
| Connector              | Terminal | Connector | Terminal |            |
| E21                    | 4        | M160      | 138      | Existed    |

2. Also check harness for short to ground and short to power.

Is the inspection result normal?

YES >> GO TO 9.

NO >> Repair open circuit, short to ground or short to power in harness or connectors.

## 9. CHECK BATTERY CURRENT SENSOR

Refer to [EC-1910, "Component Inspection \(Battery Current Sensor\)"](#).

Is the inspection result normal?

YES >> GO TO 10.

NO >> Replace battery negative cable assembly.

## 10. CHECK INTERMITTENT INCIDENT

Refer to [GI-44, "Intermittent Incident"](#).

>> INSPECTION END

## Component Inspection (Battery Current Sensor)

INFOID:000000007758471

### 1. CHECK BATTERY CURRENT SENSOR

1. Turn ignition switch OFF.
2. Reconnect harness connectors disconnected.
3. Disconnect battery negative cable.
4. Install jumper cable between battery negative terminal and body ground.
5. Turn ignition switch ON.
6. Check the voltage between ECM harness connector terminals under the following conditions.

| Connector | ECM                                    |          | Voltage (V) |
|-----------|--|----------|-------------|
|           | +                                      | -        |             |
|           | Terminal                               | Terminal |             |
| M160      | 138<br>(Battery current sensor signal) | 150      | Approx. 2.5 |

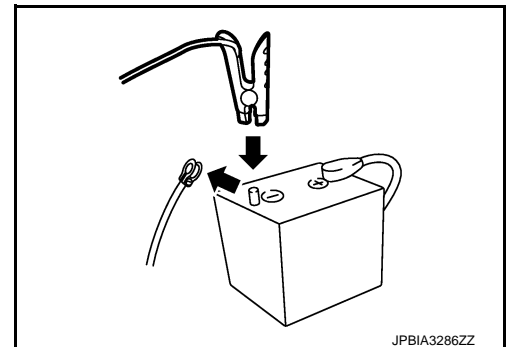

JPBIA3286ZZ

# P1551, P1552 BATTERY CURRENT SENSOR

< DTC/CIRCUIT DIAGNOSIS >

[VK56VD FOR MEXICO]

Before measuring the terminal voltage, confirm that the battery is fully charged. Refer to [PG-135, "How to Handle Battery"](#).

Is the inspection result normal?

YES >> INSPECTION END

NO >> Replace battery negative cable assembly.

A

EC

C

D

E

F

G

H

I

J

K

L

M

N

O

P

# P1553 BATTERY CURRENT SENSOR

< DTC/CIRCUIT DIAGNOSIS >

[VK56VD FOR MEXICO]

## P1553 BATTERY CURRENT SENSOR

### DTC Logic

INFOID:000000007758472

### DTC DETECTION LOGIC

| DTC No. | Trouble diagnosis name<br>(Trouble diagnosis content)      | DTC detecting condition  | Possible cause  |
|---------|--|--|---|
| P1553   | BAT CURRENT SENSOR<br>(Battery current sensor performance) | The signal voltage transmitted from the sensor to ECM is higher than the amount of the maximum power generation. | <ul style="list-style-type: none"> <li>• Harness or connectors<br/>(Battery current sensor circuit is shorted.)<br/>(Crankshaft position sensor circuit is open or shorted.)<br/>[Camshaft position sensor (bank 1) circuit is shorted.]<br/>(Accelerator pedal position sensor 2 circuit is shorted.)<br/>(EVAP control system pressure sensor circuit is shorted.)<br/>(Refrigerant pressure sensor circuit is shorted.)</li> <li>• Battery current sensor</li> <li>• Crankshaft position sensor</li> <li>• Camshaft position sensor (bank 1)</li> <li>• Accelerator pedal position sensor 2</li> <li>• EVAP control system pressure sensor</li> <li>• Refrigerant pressure sensor</li> </ul> |

### DTC CONFIRMATION PROCEDURE

#### 1. PRECONDITIONING

1. Turn ignition switch OFF and wait at least 10 seconds.
2. Turn ignition switch ON.
3. Turn ignition switch OFF and wait at least 10 seconds.

#### TESTING CONDITION:

**Before performing the following procedure, confirm that battery voltage is 8 V or more at idle.**

>> GO TO 2.

#### 2. PERFORM DTC CONFIRMATION PROCEDURE

1. Start engine and let it idle for least 10 seconds.
2. Check 1st trip DTC.

#### Is 1st trip DTC detected?

- YES >> Proceed to [EC-1912, "Diagnosis Procedure"](#).  
NO >> INSPECTION END

### Diagnosis Procedure

INFOID:000000007758473

#### 1. CHECK BATTERY CURRENT SENSOR POWER SUPPLY CIRCUIT-I

1. Disconnect battery current sensor harness connector.
2. Turn ignition switch ON.
3. Check the voltage between battery current sensor harness connector and ground.

| Battery current sensor |          | Ground | Voltage (V) |
|------------------------|----------|--------|-------------|
| Connector              | Terminal |        |             |
| E21                    | 1        | Ground | Approx. 5   |

#### Is the inspection result normal?

- YES >> GO TO 7.  
NO >> GO TO 2.

#### 2. CHECK BATTERY CURRENT SENSOR POWER SUPPLY CIRCUIT-II



# P1553 BATTERY CURRENT SENSOR

< DTC/CIRCUIT DIAGNOSIS >

[VK56VD FOR MEXICO]

1. Turn ignition switch ON.
2. Disconnect ECM harness connector.
3. Check the continuity between battery current sensor harness connector and ECM harness connector.

| Battery current sensor |          | ECM       |          | Continuity |
|------------------------|----------|-----------|----------|------------|
| Connector              | Terminal | Connector | Terminal |            |
| E21                    | 1        | M160      | 133      | Existed    |

Is the inspection result normal?

YES >> GO TO 31

NO >> Repair open circuit.

## 3.CHECK SENSOR POWER SUPPLY CIRCUIT

Check harness for short to power and short to ground, between the following terminals.

| ECM       |          | Sensor                              |           |          |
|-----------|----------|-------------------------------------|-----------|----------|
| Connector | Terminal | Name                                | Connector | Terminal |
| F111      | 76       | CKP sensor                          | F2        | 1        |
|           | 77       | Camshaft position sensor (bank 1)   | F84       | 1        |
| M160      | 133      | Battery current sensor              | E21       | 1        |
|           | 133      | EVAP control system pressure sensor | B73       | 3        |
|           | 133      | Refrigerant pressure sensor         | E77       | 3        |
|           | 131      | APP sensor 2 (Without ICC)          | M9        | 6        |
|           | 131      | APP sensor 2 (With ICC)             | M153      | 3        |

Is the inspection result normal?

YES >> GO TO 4.

NO >> Repair short to ground or short to power in harness or connectors.

## 4.CHECK COMPONENTS

Check the following.

- Camshaft position sensor (bank 1) (Refer to [EC-1831, "Component Inspection \(Camshaft Position Sensor\)"](#).)
- CKP sensor (Refer to [EC-1826, "Component Inspection \(Crankshaft Position Sensor\)"](#).)
- EVAP control system pressure sensor (Refer to [EC-1974, "Component Inspection \(EVAP Control System Pressure Sensor\)"](#).)
- Refrigerant pressure sensor (Refer to [EC-2001, "Diagnosis Procedure"](#).)

Is the inspection result normal?

YES >> GO TO 5.

NO >> Replace malfunctioning component.

## 5.CHECK APP SENSOR

Refer to [EC-1960, "Component Inspection \(Accelerator Pedal Position Sensor\)"](#).

Is the inspection result normal?

YES >> GO TO 10.

NO >> GO TO 6.

## 6.REPLACE ACCELERATOR PEDAL ASSEMBLY

Replace accelerator pedal assembly.

- Models without Distance Control Assist system: [ACC-3, "MODELS WITHOUT DISTANCE CONTROL ASSIST SYSTEM : Removal and Installation"](#)
- Models with Distance Control Assist system: [ACC-4, "MODELS WITH DISTANCE CONTROL ASSIST SYSTEM : Removal and Installation"](#)

>> INSPECTION END

# P1553 BATTERY CURRENT SENSOR

< DTC/CIRCUIT DIAGNOSIS >

[VK56VD FOR MEXICO]

## 7. CHECK BATTERY CURRENT SENSOR GROUND CIRCUIT FOR OPEN AND SHORT

1. Turn ignition switch OFF.
2. Disconnect ECM harness connector.
3. Check the continuity between battery current sensor harness connector and ECM harness connector.

| Battery current sensor |          | ECM       |          | Continuity |
|------------------------|----------|-----------|----------|------------|
| Connector              | Terminal | Connector | Terminal |            |
| E21                    | 3        | M160      | 150      | Existed    |

4. Also check harness for short to ground and short to power.

Is the inspection result normal?

YES >> GO TO 8.

NO >> Repair open circuit, short to ground or short to power in harness or connectors.

## 8. CHECK BATTERY CURRENT SENSOR INPUT SIGNAL CIRCUIT FOR OPEN AND SHORT

1. Check the continuity between battery current sensor harness connector and ECM harness connector.

| Battery current sensor |          | ECM       |          | Continuity |
|------------------------|----------|-----------|----------|------------|
| Connector              | Terminal | Connector | Terminal |            |
| E21                    | 4        | M160      | 138      | Existed    |

2. Also check harness for short to ground and short to power.

Is the inspection result normal?

YES >> GO TO 9.

NO >> Repair open circuit, short to ground or short to power in harness or connectors.

## 9. CHECK BATTERY CURRENT SENSOR

Refer to [EC-1914, "Component Inspection \(Battery Current Sensor\)"](#).

Is the inspection result normal?

YES >> GO TO 10.

NO >> Replace battery negative cable assembly.

## 10. CHECK INTERMITTENT INCIDENT

Refer to [GI-44, "Intermittent Incident"](#).

>> INSPECTION END

## Component Inspection (Battery Current Sensor)

INFOID:000000007758474

### 1. CHECK BATTERY CURRENT SENSOR

1. Turn ignition switch OFF.
2. Reconnect harness connectors disconnected.
3. Disconnect battery negative cable.
4. Install jumper cable between battery negative terminal and body ground.
5. Turn ignition switch ON.
6. Check the voltage between ECM harness connector terminals under the following conditions.

| Connector | ECM                                    |          | Voltage (V) |
|-----------|--|----------|-------------|
|           | +                                      | -        |             |
|           | Terminal                               | Terminal |             |
| M160      | 138<br>(Battery current sensor signal) | 150      | Approx. 2.5 |

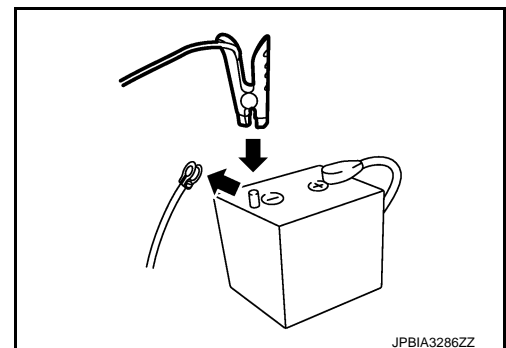

JPBIA3286ZZ

Before measuring the terminal voltage, confirm that the battery is fully charged. Refer to [PG-135, "How to Handle Battery"](#).

# P1553 BATTERY CURRENT SENSOR

< DTC/CIRCUIT DIAGNOSIS >

[VK56VD FOR MEXICO]

Is the inspection result normal?

YES >> INSPECTION END

NO >> Replace battery negative cable assembly.

A

**EC**

C

D

E

F

G

H

I

J

K

L

M

N

O

P

# P1554 BATTERY CURRENT SENSOR

[VK56VD FOR MEXICO]

< DTC/CIRCUIT DIAGNOSIS >

## P1554 BATTERY CURRENT SENSOR

### DTC Logic

INFOID:000000007758475

### DTC DETECTION LOGIC

| DTC No. | Trouble diagnosis name<br>(Trouble diagnosis content)      | DTC detecting condition  | Possible cause  |
|---------|--|--|---|
| P1554   | BAT CURRENT SENSOR<br>(Battery current sensor performance) | The output voltage of the battery current sensor is lower than the specified value while the battery voltage is high enough. | <ul style="list-style-type: none"><li>• Harness or connectors<br/>(Battery current sensor circuit is shorted.)<br/>(Crankshaft position sensor circuit is open or shorted.)<br/>[Camshaft position sensor (bank 1) circuit is shorted.]<br/>(Accelerator pedal position sensor 2 circuit is shorted.)<br/>(EVAP control system pressure sensor circuit is shorted.)<br/>(Refrigerant pressure sensor circuit is shorted.)</li><li>• Battery current sensor</li><li>• Crankshaft position sensor</li><li>• Camshaft position sensor (bank 1)</li><li>• Accelerator pedal position sensor 2</li><li>• EVAP control system pressure sensor</li><li>• Refrigerant pressure sensor</li></ul> |

### DTC CONFIRMATION PROCEDURE

#### 1. PERFORM COMPONENT FUNCTION CHECK

Perform Component Function Check. Refer to [EC-1916. "Component Function Check"](#).

#### NOTE:

Use Component Function Check to check the overall function of the battery current sensor circuit. During this check, a 1st trip DTC might not be confirmed.

Is the inspection result normal?

YES >> INSPECTION END

NO >> Proceed to [EC-1917. "Diagnosis Procedure"](#).

### Component Function Check

INFOID:000000007758476

#### 1. PRECONDITIONING

#### TESTING CONDITION:

- Before performing the following procedure, confirm that battery voltage is 12.8 V or more at idle.
- Before performing the following procedure, confirm that all load switches and A/C switch are turned OFF.

>> GO TO 2.

#### 2. PERFORM COMPONENT FUNCTION CHECK

##### ④ WITH CONSULT

1. Start engine and let it idle.
2. Select "BAT CUR SEN" in "DATA MONITOR" mode with CONSULT.
3. Check "BAT CUR SEN" indication for 10 seconds.  
"BAT CUR SEN" should be above 2,300 mV at least once.

##### ⊗ WITHOUT CONSULT

1. Start engine and let it idle.
2. Check the voltage between ECM harness connector terminals as per the following.

# P1554 BATTERY CURRENT SENSOR

< DTC/CIRCUIT DIAGNOSIS >

[VK56VD FOR MEXICO]

| ECM       |  |          | Voltage (V)             |
|-----------|--|----------|-------------------------|
| Connector | +                                      | -        |                         |
|           | Terminal                               | Terminal |                         |
| M160      | 138<br>(Battery current sensor signal) | 150      | Above 2.3 at least once |

Is the inspection result normal?

YES >> INSPECTION END

NO >> Proceed to [EC-1917, "Diagnosis Procedure"](#).

## Diagnosis Procedure

INFOID:000000007758477

### 1. CHECK BATTERY CURRENT SENSOR POWER SUPPLY CIRCUIT-I

1. Disconnect battery current sensor harness connector.
2. Turn ignition switch ON.
3. Check the voltage between battery current sensor harness connector and ground.

| Battery current sensor |          | Ground | Voltage (V) |
|------------------------|----------|--------|-------------|
| Connector              | Terminal |        |             |
| E21                    | 1        | Ground | Approx. 5   |

Is the inspection result normal?

YES >> GO TO 7.

NO >> GO TO 2.

### 2. CHECK BATTERY CURRENT SENSOR POWER SUPPLY CIRCUIT-II

1. Turn ignition switch ON.
2. Disconnect ECM harness connector.
3. Check the continuity between battery current sensor harness connector and ECM harness connector.

| Battery current sensor |          | ECM       |          | Continuity |
|------------------------|----------|-----------|----------|------------|
| Connector              | Terminal | Connector | Terminal |            |
| E21                    | 1        | M160      | 133      | Existed    |

Is the inspection result normal?

YES >> GO TO 3.

NO >> Repair open circuit.

### 3. CHECK SENSOR POWER SUPPLY CIRCUIT

Check harness for short to power and short to ground, between the following terminals.

| ECM       |          | Sensor                              |           |          |
|-----------|----------|-------------------------------------|-----------|----------|
| Connector | Terminal | Name                                | Connector | Terminal |
| F111      | 76       | CKP sensor                          | F2        | 1        |
|           | 77       | Camshaft position sensor (bank 1)   | F84       | 1        |
| M160      | 133      | Battery current sensor              | E21       | 1        |
|           | 133      | EVAP control system pressure sensor | B73       | 3        |
|           | 133      | Refrigerant pressure sensor         | E77       | 3        |
|           | 131      | APP sensor 2 (Without ICC)          | M9        | 6        |
|           | 131      | APP sensor 2 (With ICC)             | M153      | 3        |

Is the inspection result normal?

YES >> GO TO 4.

NO >> Repair short to ground or short to power in harness or connectors.

# P1554 BATTERY CURRENT SENSOR

[VK56VD FOR MEXICO]

< DTC/CIRCUIT DIAGNOSIS >

## 4. CHECK COMPONENTS

Check the following.

- Camshaft position sensor (bank 1) (Refer to [EC-1831, "Component Inspection \(Camshaft Position Sensor\)"](#).)
- CKP sensor (Refer to [EC-1826, "Component Inspection \(Crankshaft Position Sensor\)"](#).)
- EVAP control system pressure sensor (Refer to [EC-1974, "Component Inspection \(EVAP Control System Pressure Sensor\)"](#).)
- Refrigerant pressure sensor (Refer to [EC-2001, "Diagnosis Procedure"](#).)

Is the inspection result normal?

YES >> GO TO 5.

NO >> Replace malfunctioning component.

## 5. CHECK APP SENSOR

Refer to [EC-1960, "Component Inspection \(Accelerator Pedal Position Sensor\)"](#).

Is the inspection result normal?

YES >> GO TO 10.

NO >> GO TO 6.

## 6. REPLACE ACCELERATOR PEDAL ASSEMBLY

Replace accelerator pedal assembly.

- Models without Distance Control Assist system: [ACC-3, "MODELS WITHOUT DISTANCE CONTROL ASSIST SYSTEM : Removal and Installation"](#)
- Models with Distance Control Assist system: [ACC-4, "MODELS WITH DISTANCE CONTROL ASSIST SYSTEM : Removal and Installation"](#)

>> INSPECTION END

## 7. CHECK BATTERY CURRENT SENSOR GROUND CIRCUIT FOR OPEN AND SHORT

1. Turn ignition switch OFF.
2. Disconnect ECM harness connector.
3. Check the continuity between battery current sensor harness connector and ECM harness connector.

| Battery current sensor |          | ECM       |          | Continuity |
|------------------------|----------|-----------|----------|------------|
| Connector              | Terminal | Connector | Terminal |            |
| E21                    | 3        | M160      | 150      | Existed    |

4. Also check harness for short to ground and short to power.

Is the inspection result normal?

YES >> GO TO 8.

NO >> Repair open circuit, short to ground or short to power in harness or connectors.

## 8. CHECK BATTERY CURRENT SENSOR INPUT SIGNAL CIRCUIT FOR OPEN AND SHORT

1. Check the continuity between battery current sensor harness connector and ECM harness connector.

| Battery current sensor |          | ECM       |          | Continuity |
|------------------------|----------|-----------|----------|------------|
| Connector              | Terminal | Connector | Terminal |            |
| E21                    | 4        | M160      | 138      | Existed    |

2. Also check harness for short to ground and short to power.

Is the inspection result normal?

YES >> GO TO 9.

NO >> Repair open circuit, short to ground or short to power in harness or connectors.

## 9. CHECK BATTERY CURRENT SENSOR

Refer to [EC-1919, "Component Inspection \(Battery Current Sensor\)"](#).

Is the inspection result normal?

# P1554 BATTERY CURRENT SENSOR

< DTC/CIRCUIT DIAGNOSIS >

[VK56VD FOR MEXICO]

- YES >> GO TO 10.
- NO >> Replace battery negative cable assembly.

## 10.CHECK INTERMITTENT INCIDENT

Refer to [GI-44. "Intermittent Incident"](#).

>> INSPECTION END

## Component Inspection (Battery Current Sensor)

INFOID:000000007758478

### 1.CHECK BATTERY CURRENT SENSOR

1. Turn ignition switch OFF.
2. Reconnect harness connectors disconnected.
3. Disconnect battery negative cable.
4. Install jumper cable between battery negative terminal and body ground.
5. Turn ignition switch ON.
6. Check the voltage between ECM harness connector terminals under the following conditions.

| Connector | ECM                                    |          | Voltage (V) |
|-----------|--|----------|-------------|
|           | +                                      | -        |             |
|           | Terminal                               | Terminal |             |
| M160      | 138<br>(Battery current sensor signal) | 150      | Approx. 2.5 |

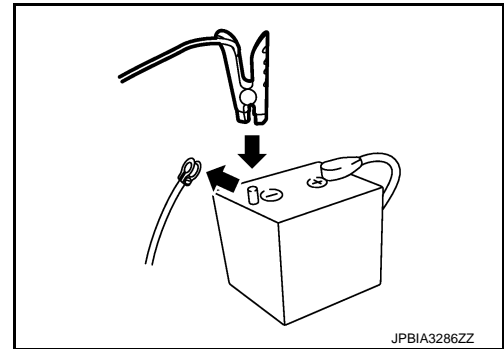

Before measuring the terminal voltage, confirm that the battery is fully charged. Refer to [PG-135. "How to Handle Battery"](#).

Is the inspection result normal?

- YES >> INSPECTION END
- NO >> Replace battery negative cable assembly.

# P1556, P1557 BATTERY TEMPERATURE SENSOR

< DTC/CIRCUIT DIAGNOSIS >

[VK56VD FOR MEXICO]

## P1556, P1557 BATTERY TEMPERATURE SENSOR

### DTC Logic

INFOID:000000007758479

### DTC DETECTION LOGIC

| DTC No. | Trouble diagnosis name<br>(Trouble diagnosis content)               | DTC detecting condition   | Possible cause  |
|---------|---|---|---|
| P1556   | BAT TMP SEN/CIRC<br>(Battery temperature sensor circuit low input)  | Signal voltage from Battery temperature sensor remains 0.16V or less for 5 seconds or more. | <ul style="list-style-type: none"> <li>• Harness or connectors<br/>[Battery current sensor (Battery temperature sensor) circuit is shorted.]<br/>(Crankshaft position sensor circuit is open or shorted.)<br/>[Camshaft position sensor (bank 1) circuit is shorted.]<br/>(Accelerator pedal position sensor 2 circuit is shorted.)<br/>(EVAP control system pressure sensor circuit is shorted.)<br/>(Refrigerant pressure sensor circuit is shorted.)</li> <li>• Battery current sensor (Battery temperature sensor)</li> <li>• Crankshaft position sensor</li> <li>• Camshaft position sensor (bank 1)</li> <li>• Accelerator pedal position sensor 2</li> <li>• EVAP control system pressure sensor</li> <li>• Refrigerant pressure sensor</li> </ul> |
| P1557   | BAT TMP SEN/CIRC<br>(Battery temperature sensor circuit high input) | Signal voltage from Battery temperature sensor remains 4.84V or more for 5 seconds or more. |   |

### DTC CONFIRMATION PROCEDURE

#### 1. PRECONDITIONING

1. Turn ignition switch OFF and wait at least 10 seconds.
2. Turn ignition switch ON.
3. Turn ignition switch OFF and wait at least 10 seconds.

#### TESTING CONDITION:

Before performing the following procedure, confirm that battery voltage is 10 V or more at idle.

>> GO TO 2.

#### 2. PERFORM DTC CONFIRMATION PROCEDURE

1. Start the engine and let it idle at least 10 seconds.
2. Check 1st trip DTC.

Is 1st trip DTC detected?

YES >> Proceed to [EC-1920, "Diagnosis Procedure"](#).

NO >> INSPECTION END

### Diagnosis Procedure

INFOID:000000007758480

#### 1. CHECK BATTERY TEMPERATURE SENSOR INPUT SIGNAL CIRCUIT-I

1. Disconnect battery current sensor harness connector.
2. Turn ignition switch ON.
3. Check the voltage between battery current sensor harness connector and ground.

| Battery current sensor |          | Ground | Voltage (V) |
|------------------------|----------|--------|-------------|
| Connector              | Terminal |        |             |
| E21                    | 2        | Ground | Approx. 5   |

Is the inspection result normal?

YES >> GO TO 7.



# P1556, P1557 BATTERY TEMPERATURE SENSOR

< DTC/CIRCUIT DIAGNOSIS >

[VK56VD FOR MEXICO]

NO >> GO TO 2.

## 2. CHECK BATTERY TEMPERATURE SENSOR INPUT SIGNAL CIRCUIT-II

1. Turn ignition switch ON.
2. Disconnect ECM harness connector.
3. Check the continuity between battery current sensor harness connector and ECM harness connector.

| Battery current sensor |          | ECM       |          | Continuity |
|------------------------|----------|-----------|----------|------------|
| Connector              | Terminal | Connector | Terminal |            |
| E21                    | 2        | M160      | 139      | Existed    |

Is the inspection result normal?

YES >> GO TO 3.

NO >> Repair open circuit.

## 3. CHECK SENSOR POWER SUPPLY CIRCUIT

Check harness for short to power and short to ground, between the following terminals.

| ECM       |          | Sensor                              |           |          |
|-----------|----------|-------------------------------------|-----------|----------|
| Connector | Terminal | Name                                | Connector | Terminal |
| F111      | 76       | CKP sensor                          | F2        | 1        |
|           | 77       | Camshaft position sensor (bank 1)   | F84       | 1        |
| M160      | 133      | Battery current sensor              | E21       | 1        |
|           | 133      | EVAP control system pressure sensor | B73       | 3        |
|           | 133      | Refrigerant pressure sensor         | E77       | 3        |
|           | 131      | APP sensor 2 (Without ICC)          | M9        | 6        |
|           | 131      | APP sensor 2 (With ICC)             | M153      | 3        |

Is the inspection result normal?

YES >> GO TO 4.

NO >> Repair short to ground or short to power in harness or connectors.

## 4. CHECK COMPONENTS

Check the following.

- Camshaft position sensor (bank 1) (Refer to [EC-1831, "Component Inspection \(Camshaft Position Sensor\)"](#).)
- CKP sensor (Refer to [EC-1826, "Component Inspection \(Crankshaft Position Sensor\)"](#).)
- Battery current sensor (Refer to [EC-1919, "Component Inspection \(Battery Current Sensor\)"](#).)
- EVAP control system pressure sensor (Refer to [EC-1974, "Component Inspection \(EVAP Control System Pressure Sensor\)"](#).)
- Refrigerant pressure sensor (Refer to [EC-2001, "Diagnosis Procedure"](#).)

Is the inspection result normal?

YES >> GO TO 5.

NO >> Replace malfunctioning component.

## 5. CHECK APP SENSOR

Refer to [EC-1960, "Component Inspection \(Accelerator Pedal Position Sensor\)"](#).

Is the inspection result normal?

YES >> GO TO 9.

NO >> GO TO 6.

## 6. REPLACE ACCELERATOR PEDAL ASSEMBLY

Replace accelerator pedal assembly. Refer to following.

- Models without Distance Control Assist system: [ACC-3, "MODELS WITHOUT DISTANCE CONTROL ASSIST SYSTEM : Removal and Installation"](#)

# P1556, P1557 BATTERY TEMPERATURE SENSOR

< DTC/CIRCUIT DIAGNOSIS >

[VK56VD FOR MEXICO]

- Models with Distance Control Assist system: [ACC-4. "MODELS WITH DISTANCE CONTROL ASSIST SYSTEM : Removal and Installation"](#)

>> INSPECTION END

## 7. CHECK BATTERY TEMPERATURE SENSOR GROUND CIRCUIT FOR OPEN AND SHORT

- Turn ignition switch OFF.
- Disconnect ECM harness connector.
- Check the continuity between battery current sensor harness connector and ECM harness connector.

| Battery current sensor |          | ECM       |          | Continuity |
|------------------------|----------|-----------|----------|------------|
| Connector              | Terminal | Connector | Terminal |            |
| E21                    | 3        | M160      | 150      | Existed    |

- Also check harness for short to ground and short to power.

Is the inspection result normal?

YES >> GO TO 8.

NO >> Repair open circuit, short to ground or short to power in harness or connectors.

## 8. CHECK BATTERY TEMPERATURE SENSOR

Refer to [EC-1922. "Component Inspection \(Battery Temperature Sensor\)"](#).

Is the inspection result normal?

YES >> GO TO 9.

NO >> Replace battery negative cable assembly.

## 9. CHECK INTERMITTENT INCIDENT

Refer to [GI-44. "Intermittent Incident"](#).

>> INSPECTION END

## Component Inspection (Battery Temperature Sensor)

INFOID:000000007758481

## 1. CHECK BATTERY TEMPERATURE SENSOR

- Turn ignition switch OFF.
- Disconnect battery current sensor.
- Check the resistance between battery current sensor connector terminals.

| Battery current sensor |   | Resistance   |
|------------------------|---|--|
| +                      | - |  |
| Terminal               |   |  |
| 2                      | 3 | continuity with the resistance value 100 Ω or more |

Is the inspection result normal?

YES >> INSPECTION END

NO >> Replace battery negative cable assembly.

# P1564 ASCD STEERING SWITCH

< DTC/CIRCUIT DIAGNOSIS >

[VK56VD FOR MEXICO]

## P1564 ASCD STEERING SWITCH

### DTC Logic

INFOID:000000007758482

### DTC DETECTION LOGIC

#### NOTE:

If DTC P1564 is displayed with DTC P0605, first perform the trouble diagnosis for DTC P0605. Refer to [EC-1858, "DTC Logic"](#).

| DTC No. | Trouble diagnosis name<br>(Trouble diagnosis content) | DTC detecting condition  | Possible cause  |
|---------|---|--|---|
| P1564   | ASCD SW<br>(ASCD steering switch)                     | <ul style="list-style-type: none"> <li>An excessively high voltage signal from the ASCD steering switch is sent to ECM.</li> <li>ECM detects that input signal from the ASCD steering switch is out of the specified range.</li> <li>ECM detects that the ASCD steering switch is stuck ON.</li> </ul> | <ul style="list-style-type: none"> <li>Harness or connectors<br/>(The switch circuit is open or shorted.)</li> <li>ASCD steering switch</li> <li>ECM</li> </ul> |

### DTC CONFIRMATION PROCEDURE

#### 1. PRECONDITIONING

If DTC Confirmation Procedure has been previously conducted, always perform the following procedure before conducting the next test.

- Turn ignition switch OFF and wait at least 10 seconds.
- Turn ignition switch ON.
- Turn ignition switch OFF and wait at least 10 seconds.

>> GO TO 2.

#### 2. PERFORM DTC CONFIRMATION PROCEDURE

- Turn ignition switch ON and wait at least 10 seconds.
- Press MAIN switch for at least 10 seconds, then release it and wait at least 10 seconds.
- Press CANCEL switch for at least 10 seconds, then release it and wait at least 10 seconds.
- Press RESUME/ACCELERATE switch for at least 10 seconds, then release it and wait at least 10 seconds.
- Press SET/COAST switch for at least 10 seconds, then release it and wait at least 10 seconds.
- Check DTC.

#### Is DTC detected?

- YES >> Proceed to [EC-1923, "Diagnosis Procedure"](#).  
 NO >> INSPECTION END

### Diagnosis Procedure

INFOID:000000007758483

#### 1. CHECK ASCD STEERING SWITCH CIRCUIT

##### Ⓜ WITH CONSULT

- Turn ignition switch ON.
- Select "MAIN SW", "CANCEL SW", "RESUME/ACC SW" and "SET SW" in "DATA MONITOR" mode with CONSULT.
- Check each item indication under the following conditions.

| Monitor item | Condition     | Indication |     |
|--------------|---------------|------------|-----|
| MAIN SW      | MAIN switch   | Pressed    | ON  |
|              |               | Released   | OFF |
| CANCEL SW    | CANCEL switch | Pressed    | ON  |
|              |               | Released   | OFF |

# P1564 ASCD STEERING SWITCH

< DTC/CIRCUIT DIAGNOSIS >

[VK56VD FOR MEXICO]

| Monitor item  | Condition                | Indication |     |
|---------------|--------------------------|------------|-----|
| RESUME/ACC SW | RESUME/ACCELERATE switch | Pressed    | ON  |
|               |                          | Released   | OFF |
| SET SW        | SET/COAST switch         | Pressed    | ON  |
|               |                          | Released   | OFF |

**⊗ WITHOUT CONSULT**

1. Turn ignition switch ON.
2. Check the voltage between ECM harness connector terminals under the following conditions.

| ECM       |                                      |          | Condition                            | Voltage (V) |
|-----------|--------------------------------------|----------|--------------------------------------|-------------|
| Connector | +                                    | -        |                                      |             |
|           | Terminal                             | Terminal |                                      |             |
| M160      | 128<br>(ASCD steering switch signal) | 130      | MAIN switch: Pressed                 | Approx. 0   |
|           |                                      |          | CANCEL switch: Pressed               | Approx. 1   |
|           |                                      |          | COAST/SET switch: Pressed            | Approx. 2   |
|           |                                      |          | ACCELERATE/RESUME switch: Pressed    | Approx. 3   |
|           |                                      |          | All ASCD steering switches: Released | Approx. 4   |

Is the inspection result normal?

- YES >> GO TO 7.  
NO >> GO TO 2.

## 2.CHECK ASCD STEERING SWITCH GROUND CIRCUIT FOR OPEN AND SHORT

1. Turn ignition switch OFF.
2. Disconnect ECM harness connector.
3. Disconnect combination switch harness connector.
4. Check the continuity between combination switch and ECM harness connector.

| Combination switch |          | ECM       |          | Continuity |
|--------------------|----------|-----------|----------|------------|
| Connector          | Terminal | Connector | Terminal |            |
| M303               | 16       | M160      | 130      | Existed    |

5. Also check harness for short to ground and short to power.

Is the inspection result normal?

- YES >> GO TO 4.  
NO >> GO TO 3.

## 3.DETECT MALFUNCTIONING PART

Check the following.

- Combination switch (spiral cable)
- Harness for open and short between ECM and combination switch

>> Repair open circuit, short to ground or short to power in harness or connectors.

## 4.CHECK ASCD STEERING SWITCH INPUT SIGNAL CIRCUIT FOR OPEN AND SHORT

1. Check the continuity between combination switch and ECM harness connector.

| Combination switch |          | ECM       |          | Continuity |
|--------------------|----------|-----------|----------|------------|
| Connector          | Terminal | Connector | Terminal |            |
| M303               | 13       | M160      | 128      | Existed    |

2. Also check harness for short to ground and short to power.

Is the inspection result normal?

- YES >> GO TO 6.

# P1564 ASCD STEERING SWITCH

< DTC/CIRCUIT DIAGNOSIS >

[VK56VD FOR MEXICO]

NO >> GO TO 5.

## 5. DETECT MALFUNCTIONING PART

Check the following.

- Combination switch (spiral cable)
- Harness for open and short between ECM and combination switch

>> Repair open circuit, short to ground or short to power in harness or connectors.

## 6. CHECK ASCD STEERING SWITCH

Refer to [EC-1925, "Component Inspection \(ASCD Steering Switch\)"](#).

Is the inspection result normal?

YES >> GO TO 7.

NO >> Replace ASCD steering switch. Refer to [ST-31, "Removal and Installation"](#).

## 7. CHECK INTERMITTENT INCIDENT

Refer to [GI-44, "Intermittent Incident"](#).

>> INSPECTION END

## Component Inspection (ASCD Steering Switch)

INFOID:000000007758484

## 1. CHECK ASCD STEERING SWITCH

1. Turn ignition switch OFF.
2. Disconnect combination switch (spiral cable) harness connector M303.
3. Check resistance between combination switch harness connector terminals under the following conditions.

| Combination switch |           | Condition                            | Resistance (Ω) |
|--------------------|-----------|--------------------------------------|----------------|
| Connector          | Terminals |                                      |                |
| M303               | 13 and 16 | MAIN switch: Pressed                 | Approx. 0      |
|                    |           | CANCEL switch: Pressed               | Approx. 250    |
|                    |           | SET/COAST switch: Pressed            | Approx. 660    |
|                    |           | RESUME/ACCELERATE switch: Pressed    | Approx. 1,480  |
|                    |           | All ASCD steering switches: Released | Approx. 4,000  |

Is the inspection result normal?

YES >> INSPECTION END

NO >> Replace ASCD steering switch. Refer to [ST-31, "Removal and Installation"](#).

# P1564 ICC STEERING SWITCH

< DTC/CIRCUIT DIAGNOSIS >

[VK56VD FOR MEXICO]

## P1564 ICC STEERING SWITCH

### DTC Logic

INFOID:000000007758485

### DTC DETECTION LOGIC

#### NOTE:

If DTC P1564 is displayed with DTC P0605, first perform the trouble diagnosis for DTC P0605. Refer to [EC-1858, "DTC Logic"](#).

| DTC No. | Trouble diagnosis name<br>(Trouble diagnosis content) | DTC detecting condition   | Possible cause   |
|---------|---|---|--|
| P1564   | ASCD SW<br>(ICC steering switch)                      | <ul style="list-style-type: none"><li>An excessively high voltage signal from the ICC steering switch is sent to ECM.</li><li>ECM detects that input signal from the ICC steering switch is out of the specified range.</li><li>ECM detects that the ICC steering switch is stuck ON.</li></ul> | <ul style="list-style-type: none"><li>Harness or connectors<br/>(The switch circuit is open or shorted.)</li><li>ICC steering switch</li><li>ECM</li></ul> |

### DTC CONFIRMATION PROCEDURE

#### 1. PRECONDITIONING

If DTC Confirmation Procedure has been previously conducted, always perform the following procedure before conducting the next test.

1. Turn ignition switch OFF and wait at least 10 seconds.
2. Turn ignition switch ON.
3. Turn ignition switch OFF and wait at least 10 seconds.

>> GO TO 2.

#### 2. PERFORM DTC CONFIRMATION PROCEDURE

1. Turn ignition switch ON and wait at least 10 seconds.
2. Press MAIN switch for at least 10 seconds, then release it and wait at least 10 seconds.
3. Press CANCEL switch for at least 10 seconds, then release it and wait at least 10 seconds.
4. Press RESUME/ACCELERATE switch for at least 10 seconds, then release it and wait at least 10 seconds.
5. Press SET/COAST switch for at least 10 seconds, then release it and wait at least 10 seconds.
6. Press DISTANCE switch for at least 10 seconds, then release it and wait at least 10 seconds.
7. Press LDP switch for at least 10 seconds, then release it and wait at least 10 seconds.
8. Check DTC.

#### Is DTC detected?

- YES >> Proceed to [EC-1926, "Diagnosis Procedure"](#).  
NO >> INSPECTION END

### Diagnosis Procedure

INFOID:000000007758486

#### 1. CHECK ICC STEERING SWITCH CIRCUIT

1. Turn ignition switch ON.
2. Check the voltage between ECM harness connector terminals under the following conditions.

# P1564 ICC STEERING SWITCH

< DTC/CIRCUIT DIAGNOSIS >

[VK56VD FOR MEXICO]

| ECM       |                                     | Condition                                | Voltage (V) |
|-----------|-------------------------------------|--|-------------|
| Connector | Terminal                            |  |             |
| M160      | 128<br>(ICC steering switch signal) | MAIN switch: Pressed                     | Approx. 0   |
|           |                                     | DYNAMIC DRIVE ASSISTANCE switch: Pressed | Approx. 1.0 |
|           |                                     | CANCEL switch: Pressed                   | Approx. 1.9 |
|           |                                     | DISTANCE switch: Pressed                 | Approx. 2.6 |
|           |                                     | COAST/SET switch: Pressed                | Approx. 3.2 |
|           |                                     | ACCELERATE/RESUME switch: Pressed        | Approx. 3.7 |
|           |                                     | All ICC steering switches: Released      | Approx. 4.2 |

Is the inspection result normal?

- YES >> GO TO 7.  
NO >> GO TO 2.

## 2.CHECK ICC STEERING SWITCH GROUND CIRCUIT FOR OPEN AND SHORT

1. Turn ignition switch OFF.
2. Disconnect ECM harness connector.
3. Disconnect combination switch harness connector.
4. Check the continuity between combination switch and ECM harness connector.

| Combination switch |          | ECM       |          | Continuity |
|--------------------|----------|-----------|----------|------------|
| Connector          | Terminal | Connector | Terminal |            |
| M303               | 16       | M160      | 130      | Existed    |

5. Also check harness for short to ground and short to power.

Is the inspection result normal?

- YES >> GO TO 4.  
NO >> GO TO 3.

## 3.DETECT MALFUNCTIONING PART

Check the following.

- Combination switch (spiral cable)
- Harness for open and short between ECM and combination switch

>> Repair open circuit, short to ground or short to power in harness or connectors.

## 4.CHECK ICC STEERING SWITCH INPUT SIGNAL CIRCUIT FOR OPEN AND SHORT

1. Check the continuity between combination switch and ECM harness connector.

| Combination switch |          | ECM       |          | Continuity |
|--------------------|----------|-----------|----------|------------|
| Connector          | Terminal | Connector | Terminal |            |
| M303               | 13       | M160      | 128      | Existed    |

2. Also check harness for short to ground and short to power.

Is the inspection result normal?

- YES >> GO TO 6.  
NO >> GO TO 5.

## 5.DETECT MALFUNCTIONING PART

Check the following.

- Combination switch (spiral cable)
- Harness for open and short between ECM and combination switch

# P1564 ICC STEERING SWITCH

< DTC/CIRCUIT DIAGNOSIS >

[VK56VD FOR MEXICO]

>> Repair open circuit, short to ground or short to power in harness or connectors.

## 6. CHECK ICC STEERING SWITCH

Refer to [EC-1928, "Component Inspection \(ICC Steering Switch\)"](#).

Is the inspection result normal?

YES >> GO TO 7.

NO >> Replace ICC steering switch. Refer to [ST-31, "Removal and Installation"](#).

## 7. CHECK INTERMITTENT INCIDENT

Refer to [GI-44, "Intermittent Incident"](#).

>> INSPECTION END

## Component Inspection (ICC Steering Switch)

INFOID:000000007758487

### 1. CHECK ICC STEERING SWITCH

1. Turn ignition switch OFF.
2. Disconnect combination switch (spiral cable) harness connector M303.
3. Check resistance between combination switch harness connector terminals under the following conditions.

| Combination switch |           | Condition                                | Resistance ( $\Omega$ ) |
|--------------------|-----------|--|-------------------------|
| Connector          | Terminals |  |                         |
| M303               | 13 and 16 | MAIN switch: Pressed                     | Approx. 0               |
|                    |           | DYNAMIC DRIVE ASSISTANCE switch: Pressed | Approx. 270             |
|                    |           | CANCEL switch: Pressed                   | Approx. 620             |
|                    |           | DISTANCE switch: Pressed                 | Approx. 1,100           |
|                    |           | SET/COAST switch: Pressed                | Approx. 1,810           |
|                    |           | RESUME/ACCELERATE switch: Pressed        | Approx. 3,000           |
|                    |           | All ICC steering switches: Released      | Approx. 5,420           |

Is the inspection result normal?

YES >> INSPECTION END

NO >> Replace ICC steering switch. Refer to [ST-31, "Removal and Installation"](#).



P1568 ICC FUNCTION

DTC Logic

INFOID:000000007758488

DTC DETECTION LOGIC

NOTE:

- If DTC P1568 is displayed with DTC UXXXX, perform the trouble diagnosis for DTC UXXXX.
- If DTC P1568 is displayed with DTC P0605, perform the trouble diagnosis for DTC P0605. Refer to [EC-1858, "DTC Logic"](#).
- If DTC P1568 is displayed with DTC P0607, perform the trouble diagnosis for DTC P0607. Refer to [EC-1860, "DTC Logic"](#).

| DTC No. | Trouble diagnosis name<br>(Trouble diagnosis content) | DTC Detecting Condition  | Possible Cause   |
|---------|---|--|--|
| P1568   | ICC COMMAND VALUE<br>(ICC function)                   | ECM detects a difference between signals from ADAS control unit is out of specified range. | <ul style="list-style-type: none"> <li>• Harness or connectors<br/>(The CAN communication line is open or shorted.)</li> <li>• ADAS control unit</li> <li>• ECM</li> </ul> |

DTC CONFIRMATION PROCEDURE

1. PRECONDITIONING

If DTC Confirmation Procedure has been previously conducted, always perform the following procedure before conducting the next test.

1. Turn ignition switch OFF and wait at least 10 seconds.
2. Turn ignition switch ON.
3. Turn ignition switch OFF and wait at least 10 seconds.

TESTING CONDITION:

**Step 2 may be conducted with the drive wheels lifted in the shop or by driving the vehicle. If a road test is expected to be easier, it is unnecessary to lift the vehicle.**

>> GO TO 2.

2. PERFORM DTC CONFIRMATION PROCEDURE

1. Turn ignition switch ON.
2. Press MAIN switch on ICC steering switch.
3. Drive the vehicle at more than 40 km/h (25 MPH).

**CAUTION:**

**Always drive vehicle at a safe speed.**

4. Press SET/COAST switch.
5. Check DTC.

Is DTC detected?

- YES >> Proceed to [EC-1929, "Diagnosis Procedure"](#).  
 NO >> INSPECTION END

Diagnosis Procedure

INFOID:000000007758489

1. REPLACE ADAS CONTROL UNIT

1. Replace ADAS control unit. Refer to [DAS-55, "Removal and Installation"](#).
2. Check DTC of ADAS control unit. Refer to [DAS-22, "CONSULT Function \(ICC/ADAS\)"](#).

>> INSPECTION END

# P1572 ICC BRAKE SWITCH

[VK56VD FOR MEXICO]

< DTC/CIRCUIT DIAGNOSIS >

## P1572 ICC BRAKE SWITCH

### DTC Logic

INFOID:000000007758494

#### DTC DETECTION LOGIC

##### NOTE:

- If DTC P1572 is displayed with DTC P0605, first perform the trouble diagnosis for DTC P0605. Refer to [EC-1858, "DTC Logic"](#).
- This self-diagnosis has the one trip detection logic. When malfunction A is detected, DTC is not stored in ECM memory. And in that case, 1st trip DTC and 1st trip freeze frame data are displayed. 1st trip DTC is erased when ignition switch is turned OFF. And even when malfunction A is detected in two consecutive trips, DTC is not stored in ECM memory.

| DTC No. | Trouble diagnosis name<br>(Trouble diagnosis content) | DTC detecting condition |  | Possible cause  |
|---------|---|-------------------------|--|---|
| P1572   | ASCD BRAKE SW<br>(ICC brake switch)                   | A)                      | ON signals from the stop lamp switch and the ICC brake switch are sent to ECM at the same time.      | <ul style="list-style-type: none"> <li>• Harness or connectors (The stop lamp switch circuit is shorted.)</li> <li>• Harness or connectors (The ICC brake switch circuit is shorted.)</li> <li>• Stop lamp switch</li> <li>• ICC brake switch</li> <li>• ICC brake hold relay</li> <li>• Incorrect stop lamp switch installation</li> <li>• Incorrect ICC brake switch installation</li> <li>• ECM</li> </ul> |
|         |   | B)                      | ICC brake switch signal is not sent to ECM for extremely long time while the vehicle is being driven |   |

#### DTC CONFIRMATION PROCEDURE

##### 1. PRECONDITIONING

1. Turn ignition switch OFF and wait at least 10 seconds.
2. Turn ignition switch ON.
3. Turn ignition switch OFF and wait at least 10 seconds.

##### NOTE:

The procedure for malfunction B is not described. It takes an extremely long time to complete the procedure for malfunction B. By performing the procedure for malfunction A, the condition that causes malfunction B can be detected.

>> GO TO 2.

##### 2. PERFORM DTC CONFIRMATION PROCEDURE

1. Start engine (VDC switch OFF).
2. Press MAIN switch and check that CRUISE indicator is displayed in combination meter.
3. Drive the vehicle for at least 5 consecutive seconds under the following conditions.

##### CAUTION:

**Always drive vehicle at a safe speed.**

##### NOTE:

**This procedure may be conducted with the drive wheels lifted in the shop or by driving the vehicle. If a road test is expected to be easier, it is unnecessary to lift the vehicle.**

|                |                            |
|----------------|----------------------------|
| Vehicle speed  | More than 30 km/h (19 mph) |
| Selector lever | Suitable position          |

4. Check 1st trip DTC.

Is 1st trip DTC detected?

YES >> Proceed to [EC-1931, "Diagnosis Procedure"](#).

NO >> GO TO 3.

##### 3. PERFORM DTC CONFIRMATION PROCEDURE

1. Drive the vehicle for at least 5 consecutive seconds under the following conditions.

##### CAUTION:

# P1572 ICC BRAKE SWITCH

< DTC/CIRCUIT DIAGNOSIS >

[VK56VD FOR MEXICO]

**Always drive vehicle at a safe speed.**

**NOTE:**

**This procedure may be conducted with the drive wheels lifted in the shop or by driving the vehicle. If a road test is expected to be easier, it is unnecessary to lift the vehicle.**

|                  |   |
|------------------|---|
| Vehicle speed    | More than 30 km/h (19 mph)  |
| Selector lever   | Suitable position   |
| Driving location | Depress the brake pedal for more than 5 seconds so as not to come off from the above-mentioned vehicle speed. |

2. Check 1st trip DTC.

Is 1st trip DTC detected?

- YES >> Proceed to [EC-1931, "Diagnosis Procedure"](#).
- NO >> INSPECTION END

## Diagnosis Procedure

INFOID:000000007785842

### 1.CHECK OVERALL FUNCTION-I

**④ With CONSULT**

1. Turn ignition switch ON.
2. Select "BRAKE SW1" in "DATA MONITOR" mode with CONSULT.
3. Check "BRAKE SW1" indication under the following conditions.

| Monitor item                    | Condition   |                    | Indication |
|---------------------------------|-------------|--------------------|------------|
| BRAKE SW1<br>(ICC brake switch) | Brake pedal | Slightly depressed | OFF        |
|                                 | Brake pedal | Fully released     | ON         |

**⊗ Without CONSULT**

1. Turn ignition switch ON.
2. Check the voltage between ECM harness connector terminals under the following conditions.

| Connector | ECM                              |     | Condition                         | Voltage (V)     |
|-----------|----------------------------------|-----|-----------------------------------|-----------------|
|           | +                                | -   |                                   |                 |
|           | Terminal                         |     |                                   |                 |
| E80       | 147<br>(ICC brake switch signal) | 175 | Brake pedal<br>Slightly depressed | Approx. 0       |
|           |                                  |     | Brake pedal<br>Fully released     | Battery voltage |

Is the inspection result normal?

- YES >> GO TO 2.
- NO >> GO TO 3.

### 2.CHECK OVERALL FUNCTION-II

**④ With CONSULT**

Select "BRAKE SW2" and check indication under the following conditions.

| Monitor item                    | Condition   |                    | Indication |
|---------------------------------|-------------|--------------------|------------|
| BRAKE SW2<br>(Stop lamp switch) | Brake pedal | Slightly depressed | ON         |
|                                 |             | Fully released     | OFF        |

**⊗ Without CONSULT**

Check the voltage between ECM harness connector terminals as per the following.

# P1572 ICC BRAKE SWITCH

[VK56VD FOR MEXICO]

< DTC/CIRCUIT DIAGNOSIS >

| ECM       |                                  |          | Condition      | Voltage (V)        |                 |
|-----------|----------------------------------|----------|----------------|--------------------|-----------------|
| Connector | +                                | -        |                |                    |                 |
|           | Terminal                         | Terminal |                |                    |                 |
| E80       | 158<br>(Stop lamp switch signal) | 175      | Brake pedal    | Slightly depressed | Battery voltage |
|           |                                  |          | Fully released | Approx. 0          |                 |

Is the inspection result normal?

- YES >> GO TO 14.  
NO >> GO TO 8.

## 3. CHECK ICC BRAKE SWITCH POWER SUPPLY CIRCUIT

1. Turn ignition switch OFF.
2. Disconnect ICC brake switch harness connector.
3. Turn ignition switch ON.
4. Check the voltage between ICC brake switch harness connector and ground.

| ICC brake switch |          | Ground | Voltage         |
|------------------|----------|--------|-----------------|
| Connector        | Terminal |        |                 |
| E68              | 1        | Ground | Battery voltage |

Is the inspection result normal?

- YES >> GO TO 5.  
NO >> GO TO 4.

## 4. DETECT MALFUNCTIONING PART

Check the following.

- Fuse block (J/B) connector E103
- 10 A fuse (No. 3)
- Harness for open or short between ICC brake switch and fuse

>> Repair open circuit or short to ground in harness or connectors.

## 5. CHECK ICC BRAKE SWITCH INPUT SIGNAL CIRCUIT FOR OPEN AND SHORT

1. Turn ignition switch OFF.
2. Disconnect ECM harness connector.
3. Check the continuity between ICC brake switch harness connector and ECM harness connector.

| ICC brake switch |          | ECM       |          | Continuity |
|------------------|----------|-----------|----------|------------|
| Connector        | Terminal | Connector | Terminal |            |
| E68              | 2        | E80       | 147      | Existed    |

4. Also check harness for short to ground and short to power.

Is the inspection result normal?

- YES >> GO TO 7.  
NO >> GO TO 6.

## 6. DETECT MALFUNCTIONING PART

Check the following.

- Harness for open or short between ICC brake switch and ECM

>> Repair open circuit, short to ground or short to power in harness or connectors.

## 7. CHECK ICC BRAKE SWITCH

Refer to [EC-1934, "Component Inspection \(ICC Brake Switch\)"](#).

Is the inspection result normal?

# P1572 ICC BRAKE SWITCH

[VK56VD FOR MEXICO]

## < DTC/CIRCUIT DIAGNOSIS >

YES >> GO TO 14.

NO >> Replace ICC brake switch. Refer to [BR-18, "Exploded View"](#).

### 8. CHECK STOP LAMP SWITCH POWER SUPPLY CIRCUIT

1. Turn ignition switch OFF.
2. Disconnect stop lamp switch harness connector.
3. Disconnect ICC brake hold relay harness connector.
4. Check the voltage between stop lamp switch harness connector and ground.

| Stop lamp switch |          | Ground | Voltage         |
|------------------|----------|--------|-----------------|
| Connector        | Terminal |        |                 |
| E115             | 1        | Ground | Battery voltage |

5. Check the voltage between ICC brake hold relay harness connector and ground.

| ICC brake hold relay |          | Ground | Voltage         |
|----------------------|----------|--------|-----------------|
| Connector            | Terminal |        |                 |
| E64                  | 3        | Ground | Battery voltage |

Is the inspection result normal?

YES >> GO TO 10.

NO >> GO TO 9.

### 9. DETECT MALFUNCTIONING PART

Check the following.

- Fuse block (J/B) connector E103
- 10 A fuse (No. 7)
- Harness for open or short between battery and stop lamp switch
- Harness for open or short between battery and ICC brake hold relay

>> Repair open circuit or short to ground in harness or connectors.

### 10. CHECK STOP LAMP SWITCH INPUT SIGNAL CIRCUIT FOR OPEN AND SHORT

1. Disconnect ECM harness connector.
2. Check the continuity between stop lamp switch harness connector and ECM harness connector.

| Stop lamp switch |          | ECM       |          | Continuity |
|------------------|----------|-----------|----------|------------|
| Connector        | Terminal | Connector | Terminal |            |
| E115             | 2        | E80       | 158      | Existed    |

3. Check the continuity between ICC brake hold relay harness connector and ECM harness connector.

| ICC brake hold relay |          | ECM       |          | Continuity |
|----------------------|----------|-----------|----------|------------|
| Connector            | Terminal | Connector | Terminal |            |
| E64                  | 5        | E80       | 158      | Existed    |

4. Also check harness for short to ground and short to power.

Is the inspection result normal?

YES >> GO TO 12.

NO >> GO TO 11.

### 11. DETECT MALFUNCTIONING PART

Check the following.

- Fuse block (J/B) connector E103
- Harness for open or short between ECM and stop lamp switch
- Harness for open or short between ECM and ICC brake hold relay

# P1572 ICC BRAKE SWITCH

[VK56VD FOR MEXICO]

## < DTC/CIRCUIT DIAGNOSIS >

>> Repair open circuit, short to ground or short to power in harness or connectors.

### 12.CHECK STOP LAMP SWITCH

Refer to [EC-1934, "Component Inspection \(Stop Lamp Switch\)"](#).

Is the inspection result normal?

YES >> GO TO 13.

NO >> Replace stop lamp switch. Refer to [BR-18, "Exploded View"](#).

### 13.CHECK ICC BRAKE HOLD RELAY

Refer to [EC-1935, "Component Inspection \(ICC Brake Hold Relay\)"](#).

Is the inspection result normal?

YES >> GO TO 14.

NO >> Replace ICC brake hold relay.

### 14.CHECK INTERMITTENT INCIDENT

Refer to [GI-44, "Intermittent Incident"](#).

>> INSPECTION END

## Component Inspection (ICC Brake Switch)

INFOID:000000007758496

### 1.CHECK ICC BRAKE SWITCH-I

1. Turn ignition switch OFF.
2. Disconnect ICC brake switch harness connector.
3. Check the continuity between ICC brake switch terminals under the following conditions.

| Terminals | Condition   |                    | Continuity  |
|-----------|-------------|--------------------|-------------|
| 1 and 2   | Brake pedal | Fully released     | Existed     |
|           |             | Slightly depressed | Not existed |

Is the inspection result normal?

YES >> INSPECTION END

NO >> GO TO 2.

### 2.CHECK ICC BRAKE SWITCH-II

1. Adjust ICC brake switch installation. Refer to [BR-7, "Inspection and Adjustment"](#).
2. Check the continuity between ICC brake switch terminals under the following conditions.

| Terminals | Condition   |                    | Continuity  |
|-----------|-------------|--------------------|-------------|
| 1 and 2   | Brake pedal | Fully released     | Existed     |
|           |             | Slightly depressed | Not existed |

Is the inspection result normal?

YES >> INSPECTION END

NO >> Replace ICC brake switch.

## Component Inspection (Stop Lamp Switch)

INFOID:000000007758497

### 1.CHECK STOP LAMP SWITCH-I

1. Turn ignition switch OFF.
2. Disconnect stop lamp switch harness connector.
3. Check the continuity between stop lamp switch terminals under the following conditions.

| Terminals | Condition   |                    | Continuity  |
|-----------|-------------|--------------------|-------------|
| 1 and 2   | Brake pedal | Fully released     | Not existed |
|           |             | Slightly depressed | Existed     |

# P1572 ICC BRAKE SWITCH

[VK56VD FOR MEXICO]

## < DTC/CIRCUIT DIAGNOSIS >

Is the inspection result normal?

- YES >> INSPECTION END
- NO >> GO TO 2.

### 2.CHECK STOP LAMP SWITCH-II

1. Adjust stop lamp switch installation. Refer to [BR-7, "Inspection and Adjustment"](#).
2. Check the continuity between stop lamp switch terminals under the following conditions.

| Terminals | Condition   |                    | Continuity  |
|-----------|-------------|--------------------|-------------|
| 1 and 2   | Brake pedal | Fully released     | Not existed |
|           |             | Slightly depressed | Existed     |

Is the inspection result normal?

- YES >> INSPECTION END
- NO >> Replace stop lamp switch. Refer to [BR-18, "Exploded View"](#).

## Component Inspection (ICC Brake Hold Relay)

INFOID:000000007793849

### 1.CHECK ICC BRAKE HOLD RELAY

1. Turn ignition switch OFF.
2. Remove ICC brake hold relay.
3. Check the continuity between ICC brake hold relay terminals under the following conditions.

| Terminals | Condition   | Continuity  |
|-----------|---|-------------|
| 3 and 5   | 12V direct current supply between terminals 1 and 2 | Existed     |
|           | No current supply                                   | Not existed |

Is the inspection result normal?

- YES >> INSPECTION END
- NO >> Replace ICC brake hold relay

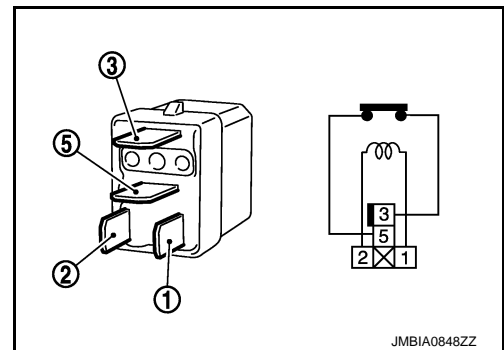

# P1574 ASCD VEHICLE SPEED SENSOR

< DTC/CIRCUIT DIAGNOSIS >

[VK56VD FOR MEXICO]

## P1574 ASCD VEHICLE SPEED SENSOR

### Description

INFOID:000000007758498

The ECM receives two vehicle speed signals by the CAN communication line. One is sent from “combination meter”, and the other is from TCM (Transmission control module). The ECM uses these signals for ASCD control. Refer to [CCS-172, "Information"](#) for ASCD functions.

### DTC Logic

INFOID:000000007758499

#### DTC DETECTION LOGIC

##### NOTE:

- If DTC P1574 is displayed with DTC UXXXX, perform the trouble diagnosis for DTC UXXXX.
- If DTC P1574 is displayed with DTC P0500, perform the trouble diagnosis for DTC P0500. Refer to [EC-1841, "DTC Logic"](#).
- If DTC P1574 is displayed with DTC P0605, perform the trouble diagnosis for DTC P0605. Refer to [EC-1858, "DTC Logic"](#).
- If DTC P1574 is displayed with DTC P0607, perform the trouble diagnosis for DTC P0607. Refer to [EC-1860, "DTC Logic"](#).

| DTC No. | Trouble diagnosis name<br>(Trouble diagnosis content) | DTC detecting condition   | Possible cause  |
|---------|---|---|---|
| P1574   | ASCD VHL SPD SEN<br>(ASCD vehicle speed sensor)       | ECM detects a difference between two vehicle speed signals is out of the specified range. | <ul style="list-style-type: none"><li>• Harness or connectors<br/>(The CAN communication line is open or shorted.)</li><li>• Combination meter</li><li>• ABS actuator and electric unit (control unit)</li><li>• Wheel sensor</li><li>• TCM</li><li>• ECM</li></ul> |

#### DTC CONFIRMATION PROCEDURE

##### 1. PRECONDITIONING

1. Turn ignition switch OFF and wait at least 10 seconds.
2. Turn ignition switch ON.
3. Turn ignition switch OFF and wait at least 10 seconds.

>> GO TO 2.

##### 2. PERFORM DTC CONFIRMATION PROCEDURE

1. Start engine (VDC switch OFF).
2. Drive the vehicle at more than 40 km/h (25 MPH).

##### CAUTION:

**Always drive vehicle at a safe speed.**

##### NOTE:

**This procedure may be conducted with the drive wheels lifted in the shop or by driving the vehicle. If a road test is expected to be easier, it is unnecessary to lift the vehicle.**

3. Check DTC.

##### Is DTC detected?

- YES >> Proceed to [EC-1936, "Diagnosis Procedure"](#).  
NO >> INSPECTION END

#### Diagnosis Procedure

INFOID:000000007758500

##### 1. CHECK DTC WITH TCM

Check DTC with TCM. Refer to [TM-60, "CONSULT Function"](#).

##### Is the inspection result normal?

- YES >> GO TO 2.



# P1574 ASCD VEHICLE SPEED SENSOR

[VK56VD FOR MEXICO]

< DTC/CIRCUIT DIAGNOSIS >

NO >> Perform Diagnosis Procedure corresponding to the DTC indicated.

## 2.CHECK DTC WITH “ABS ACTUATOR AND ELECTRIC UNIT (CONTROL UNIT)”

Refer to [BRC-40. "CONSULT Function"](#).

Is the inspection result normal?

YES >> GO TO 3.

NO >> Perform Diagnosis Procedure corresponding to the DTC indicated.

## 3.CHECK DTC WITH “COMBINATION METER”

Refer to [MWI-31. "CONSULT Function"](#).

>> INSPECTION END

A

EC

C

D

E

F

G

H

I

J

K

L

M

N

O

P

# P1574 ICC VEHICLE SPEED SENSOR

< DTC/CIRCUIT DIAGNOSIS >

[VK56VD FOR MEXICO]

## P1574 ICC VEHICLE SPEED SENSOR

### Description

INFOID:000000007758501

The ECM receives two vehicle speed signals by the CAN communication line. One is sent from “combination meter”, and the other is from TCM (Transmission control module). The ECM uses these signals for ICC control. Refer to [CCS-13, "System Description"](#) for ICC functions.

### DTC Logic

INFOID:000000007758502

### DTC DETECTION LOGIC

#### NOTE:

- If DTC P1574 is displayed with DTC UXXXX, first perform the trouble diagnosis for DTC UXXXX.
- If DTC P1574 is displayed with DTC P0500, first perform the trouble diagnosis for DTC P0500. Refer to [EC-1841, "DTC Logic"](#).
- If DTC P1574 is displayed with DTC P0605, first perform the trouble diagnosis for DTC P0605. Refer to [EC-1858, "DTC Logic"](#).
- If DTC P1574 is displayed with DTC P0607, first perform the trouble diagnosis for DTC P0607. Refer to [EC-1860, "DTC Logic"](#).

| DTC No. | Trouble diagnosis name<br>(Trouble diagnosis content) | DTC detecting condition   | Possible cause  |
|---------|---|---|---|
| P1574   | ASCD VHL SPD SEN<br>(ICC vehicle speed sensor)        | ECM detects a difference between two vehicle speed signals is out of the specified range. | <ul style="list-style-type: none"><li>• Harness or connectors<br/>(The CAN communication line is open or shorted.)</li><li>• Combination meter</li><li>• ABS actuator and electric unit (control unit)</li><li>• Wheel sensor</li><li>• TCM</li><li>• ECM</li></ul> |

### DTC CONFIRMATION PROCEDURE

#### 1. PRECONDITIONING

1. Turn ignition switch OFF and wait at least 10 seconds.
2. Turn ignition switch ON.
3. Turn ignition switch OFF and wait at least 10 seconds.

>> GO TO 2.

#### 2. PERFORM DTC CONFIRMATION PROCEDURE

1. Start engine (VDC switch OFF).
2. Drive the vehicle at more than 40 km/h (25 MPH).

#### CAUTION:

**Always drive vehicle at a safe speed.**

#### NOTE:

**This procedure may be conducted with the drive wheels lifted in the shop or by driving the vehicle. If a road test is expected to be easier, it is unnecessary to lift the vehicle.**

3. Check DTC.

#### Is DTC detected?

- YES >> Proceed to [EC-1938, "Diagnosis Procedure"](#).  
NO >> INSPECTION END

### Diagnosis Procedure

INFOID:000000007758503

#### 1. CHECK DTC WITH TCM

Check DTC with TCM. Refer to [TM-60, "CONSULT Function"](#).

#### Is the inspection result normal?

- YES >> GO TO 2.

# P1574 ICC VEHICLE SPEED SENSOR

[VK56VD FOR MEXICO]

< DTC/CIRCUIT DIAGNOSIS >

NO >> Perform Diagnosis Procedure corresponding to the DTC indicated.

## 2.CHECK DTC WITH “ABS ACTUATOR AND ELECTRIC UNIT (CONTROL UNIT)”

Refer to [BRC-40, "CONSULT Function"](#).

Is the inspection result normal?

YES >> GO TO 3.

NO >> Perform Diagnosis Procedure corresponding to the DTC indicated.

## 3.CHECK DTC WITH “COMBINATION METER”

Check combination meter function.

Refer to [MWI-31, "CONSULT Function"](#).

>> INSPECTION END

A

EC

C

D

E

F

G

H

I

J

K

L

M

N

O

P

# P1606 VVEL CONTROL MODULE

< DTC/CIRCUIT DIAGNOSIS >

[VK56VD FOR MEXICO]

## P1606 VVEL CONTROL MODULE

### DTC Logic

INFOID:000000007758504

### DTC DETECTION LOGIC

| DTC No. | Trouble diagnosis name<br>(Trouble diagnosis content) | DTC detecting condition   | Possible cause  |
|---------|---|---|---|
| P1606   | VVEL CONTROL MODULE<br>(VVEL control module)          | <ul style="list-style-type: none"><li>VVEL control module calculation function is malfunctioning.</li><li>VVEL EEPROM system is malfunctioning.</li></ul> | <ul style="list-style-type: none"><li>VVEL control module</li></ul> |

### DTC CONFIRMATION PROCEDURE

#### 1. PRECONDITIONING

1. Turn ignition switch OFF and wait at least 10 seconds.
2. Turn ignition switch ON.
3. Turn ignition switch OFF and wait at least 10 seconds.

#### TESTING CONDITION:

Before performing the following procedure, confirm that battery voltage is 10 V or more at idle.

>> GO TO 2.

#### 2. PERFORM DTC CONFIRMATION PROCEDURE

1. Turn ignition switch ON and wait at least 1 second.
2. Check DTC.

#### Is DTC detected?

- YES >> Proceed to [EC-1940, "Diagnosis Procedure"](#).  
NO >> INSPECTION END

### Diagnosis Procedure

INFOID:000000007758505

#### 1. PERFORM DTC CONFIRMATION PROCEDURE

1. Turn ignition switch ON.
2. Erase DTC.
3. Perform DTC Confirmation Procedure.  
See [EC-1940, "DTC Logic"](#).

#### Is the DTC P1606 displayed again?

- YES >> GO TO 2.  
NO >> INSPECTION END

#### 2. REPLACE VVEL CONTROL MODULE

1. Replace VVEL control module.
2. Perform additional service when replacing VVEL control module. Refer to [EC-1684, "Work Procedure"](#).

>> INSPECTION END

# P1607 VVEL CONTROL MODULE

< DTC/CIRCUIT DIAGNOSIS >

[VK56VD FOR MEXICO]

## P1607 VVEL CONTROL MODULE

### DTC Logic

INFOID:000000007758506

### DTC DETECTION LOGIC

| DTC No. | Trouble diagnosis name<br>(Trouble diagnosis content) | DTC detecting condition  | Possible cause  |
|---------|---|--|---|
| P1607   | VVEL CONTROL MODULE<br>(VVEL control module circuit)  | <ul style="list-style-type: none"><li>The internal circuit of the VVEL control module is malfunctioning.</li></ul> | <ul style="list-style-type: none"><li>VVEL control module</li></ul> |

### DTC CONFIRMATION PROCEDURE

#### 1. PRECONDITIONING

- Turn ignition switch OFF and wait at least 10 seconds.
- Turn ignition switch ON.
- Turn ignition switch OFF and wait at least 10 seconds.

#### TESTING CONDITION:

Before performing the following procedure, confirm that battery voltage is 10 V or more at idle.

>> GO TO 2.

#### 2. PERFORM DTC CONFIRMATION PROCEDURE

- Start engine and let it idle for at least 1 second.
- Check DTC.

#### Is DTC detected?

- YES >> Proceed to [EC-1941, "Diagnosis Procedure"](#).  
NO >> INSPECTION END

### Diagnosis Procedure

INFOID:000000007758507

#### 1. PERFORM DTC CONFIRMATION PROCEDURE

- Turn ignition switch ON.
- Erase DTC.
- Perform DTC Confirmation Procedure.  
See [EC-1941, "DTC Logic"](#).

#### Is the DTC P1607 displayed again?

- YES >> GO TO 2.  
NO >> INSPECTION END

#### 2. REPLACE VVEL CONTROL MODULE

- Replace VVEL control module.
- Perform additional service when replacing VVEL control module. Refer to [EC-1684, "Work Procedure"](#).

>> INSPECTION END

# P1608 VVEL SENSOR POWER SUPPLY

< DTC/CIRCUIT DIAGNOSIS >

[VK56VD FOR MEXICO]

## P1608 VVEL SENSOR POWER SUPPLY

### DTC Logic

INFOID:000000007758508

### DTC DETECTION LOGIC

| DTC No. | Trouble diagnosis name<br>(Trouble diagnosis content)        | DTC detecting condition  | Possible cause   |
|---------|--|--|--|
| P1608   | VVEL SENSOR POWER/CIRC<br>(VVEL sensor power supply circuit) | VVEL control module detects a voltage of power source for sensor is excessively low or high. | <ul style="list-style-type: none"> <li>• Harness or connectors (VVEL control shaft position sensor power supply circuit is open or shorted.)</li> <li>• VVEL control shaft position sensor</li> <li>• VVEL control module</li> </ul> |

### DTC CONFIRMATION PROCEDURE

#### 1. PRECONDITIONING

1. Turn ignition switch OFF and wait at least 10 seconds.
2. Turn ignition switch ON.
3. Turn ignition switch OFF and wait at least 10 seconds.

#### TESTING CONDITION:

Before performing the following procedure, confirm that battery voltage is 10 V or more at idle.

>> GO TO 2.

#### 2. PERFORM DTC CONFIRMATION PROCEDURE

1. Turn ignition switch ON and wait at least 1 second.
2. Check DTC.

#### Is DTC detected?

YES >> Proceed to [EC-1942, "Diagnosis Procedure"](#).

NO >> INSPECTION END

### Diagnosis Procedure

INFOID:000000007758509

#### 1. CHECK VVEL CONTROL SHAFT POSITION SENSOR POWER SUPPLY CIRCUIT-I

1. Disconnect VVEL control shaft position sensor harness connector.
2. Turn ignition switch ON.
3. Check the voltage between VVEL control shaft position sensor harness connector and ground.

| VVEL control shaft position sensor |           |          | Ground | Voltage     |
|------------------------------------|-----------|----------|--------|-------------|
| Bank                               | Connector | Terminal |        |             |
| 1                                  | F72       | 3        | Ground | Approx. 5 V |
|                                    |           | 6        |        |             |
| 2                                  | F70       | 3        |        |             |
|                                    |           | 6        |        |             |

#### Is the inspection result normal?

YES >> GO TO 6.

NO >> GO TO 2.

#### 2. CHECK VVEL CONTROL SHAFT POSITION SENSOR POWER SUPPLY CIRCUIT-II

1. Turn ignition switch OFF.
2. Disconnect VVEL control module harness connector.
3. Check the continuity between VVEL control shaft position sensor harness connector and VVEL control module harness connector.

# P1608 VVEL SENSOR POWER SUPPLY

< DTC/CIRCUIT DIAGNOSIS >

[VK56VD FOR MEXICO]

| VVEL control shaft position sensor |           |          | VVEL control module |          | Continuity |
|------------------------------------|-----------|----------|---------------------|----------|------------|
| Bank                               | Connector | Terminal | Connector           | Terminal |            |
| 1                                  | F72       | 3        | E15                 | 7        | Existed    |
|                                    |           | 6        |                     | 20       |            |
| 2                                  | F70       | 3        |                     | 9        |            |
|                                    |           | 6        |                     | 22       |            |

4. Also check harness for short to ground and power.

Is the inspection result normal?

YES >> GO TO 4.

NO >> GO TO 3.

## 3. DETECT MALFUNCTIONING PART

Check the following.

- Harness for open or short between VVEL control shaft position sensor and VVEL control module
- Loose or poor connection for each connector and harness

>> Repair open circuit, short to ground or short to power in harness or connectors.

## 4. CHECK INTERMITTENT INCIDENT

Refer to [GI-44, "Intermittent Incident"](#).

Is the inspection result normal?

YES >> GO TO 5.

NO >> Repair or replace.

## 5. REPLACE VVEL CONTROL MODULE

1. Replace VVEL control module.
2. Perform additional service when replacing VVEL control module. Refer to [EC-1684, "Work Procedure"](#).

>> INSPECTION END

## 6. CHECK INTERMITTENT INCIDENT

Refer to [GI-44, "Intermittent Incident"](#).

Is the inspection result normal?

YES >> GO TO 7.

NO >> Repair or replace.

## 7. REPLACE VVEL ACTUATOR SUB ASSEMBLY

Replace VVEL actuator sub assembly. Refer to [EM-264, "Exploded View"](#).

>> INSPECTION END

# P1715 INPUT SPEED SENSOR

< DTC/CIRCUIT DIAGNOSIS >

[VK56VD FOR MEXICO]

## P1715 INPUT SPEED SENSOR

### Description

INFOID:000000007758510

ECM receives input speed sensor signal from TCM by the CAN communication line. ECM uses this signal for engine control.

### DTC Logic

INFOID:000000007758511

### DTC DETECTION LOGIC

#### NOTE:

- If DTC P1715 is displayed with DTC UXXXX, perform the trouble diagnosis for DTC UXXXX.
- If DTC P1715 is displayed with DTC P0335, perform the trouble diagnosis for DTC P0335. Refer to [EC-1824, "DTC Logic"](#).
- If DTC P1715 is displayed with DTC P0340, perform the trouble diagnosis for DTC P0340. Refer to [EC-1828, "DTC Logic"](#).
- If DTC P1715 is displayed with DTC P0605, perform the trouble diagnosis for DTC P0605. Refer to [EC-1858, "DTC Logic"](#).
- If DTC P1715 is displayed with DTC P0607, perform the trouble diagnosis for DTC P0607. Refer to [EC-1860, "DTC Logic"](#).

| DTC No. | Trouble diagnosis name<br>(Trouble diagnosis content) | DTC detecting condition  | Possible cause  |
|---------|---|--|---|
| P1715   | IN PULY SPEED<br>[Input speed sensor (TCM output)]    | Input speed sensor signal is different from the theoretical value calculated by ECM from output speed sensor signal and engine rpm signal. | <ul style="list-style-type: none"><li>• Harness or connectors<br/>(The CAN communication line is open or shorted)<br/>(Input speed sensor circuit is open or shorted)</li><li>• TCM</li></ul> |

### Diagnosis Procedure

INFOID:000000007758512

#### 1.CHECK DTC WITH TCM

Check DTC with TCM. Refer to [TM-60, "CONSULT Function"](#).

Is the inspection result normal?

YES >> GO TO 2.

NO >> Perform Diagnosis Procedure corresponding to DTC indicated.

#### 2.REPLACE TCM

Replace TCM.

>> INSPECTION END



# P1805 BRAKE SWITCH

< DTC/CIRCUIT DIAGNOSIS >

[VK56VD FOR MEXICO]

## P1805 BRAKE SWITCH

### DTC Logic

INFOID:000000007758513

### DTC DETECTION LOGIC

| DTC No. | Trouble diagnosis name<br>(Trouble diagnosis content) | DTC detecting condition   | Possible cause   |
|---------|---|---|--|
| P1805   | BRAKE SW/CIRCUIT<br>(Brake switch)                    | A brake switch signal is not sent to ECM for extremely long time while the vehicle is being driven. | <ul style="list-style-type: none"> <li>Harness or connectors (Stop lamp switch circuit is open or shorted.)</li> <li>Stop lamp switch</li> </ul> |

### DTC CONFIRMATION PROCEDURE

#### 1. PERFORM DTC CONFIRMATION PROCEDURE

- Turn ignition switch ON.
- Fully depress the brake pedal for at least 5 seconds.
- Erase the DTC.
- Check 1st trip DTC.

#### Is 1st trip DTC detected?

- YES >> Proceed to [EC-1945, "Diagnosis Procedure"](#).  
 NO >> INSPECTION END

### Diagnosis Procedure

INFOID:000000007758514

#### 1. CHECK STOP LAMP SWITCH CIRCUIT

- Turn ignition switch OFF.
- Check for stop lamp illumination under the following conditions.

| Condition   |                    | Stop lamp       |
|-------------|--------------------|-----------------|
| Brake pedal | Fully released     | Not illuminated |
|             | Slightly depressed | Illuminated     |

#### Is the inspection result normal?

- YES >> GO TO 4.  
 NO >> GO TO 2.

#### 2. CHECK STOP LAMP SWITCH POWER SUPPLY CIRCUIT

- Disconnect stop lamp switch harness connector.
- Check the voltage between stop lamp switch harness connector and ground.

| Stop lamp switch |          | Ground | Voltage         |
|------------------|----------|--------|-----------------|
| Connector        | Terminal |        |                 |
| E110             | 1        | Ground | Battery voltage |

#### Is the inspection result normal?

- YES >> GO TO 4.  
 NO >> GO TO 3.

#### 3. DETECT MALFUNCTIONING PART

Check the following.

- 10 A fuse (No. 7)
- Harness for open or short between stop lamp switch and battery
- Loose or poor connection for each connector and harness

>> Repair open circuit, short to ground or short to power in harness or connectors.

# P1805 BRAKE SWITCH

< DTC/CIRCUIT DIAGNOSIS >

[VK56VD FOR MEXICO]

## 4. CHECK STOP LAMP SWITCH INPUT SIGNAL CIRCUIT FOR OPEN AND SHORT

1. Disconnect stop lamp switch harness connector.
2. Disconnect ECM harness connector.
3. Check the continuity between stop lamp switch harness connector and ECM harness connector.

| Stop lamp switch |          | ECM       |          | Continuity |
|------------------|----------|-----------|----------|------------|
| Connector        | Terminal | Connector | Terminal |            |
| E110             | 2        | M160      | 158      | Existed    |

4. Also check harness for short to ground and short to power.

Is the inspection result normal?

YES >> GO TO 6.

NO >> GO TO 5.

## 5. DETECT MALFUNCTIONING PART

Check the following.

- Harness for open or short between ECM and stop lamp switch
- Loose or poor connection for each connector and harness

>> Repair open circuit, short to ground or short to power in harness or connectors.

## 6. CHECK STOP LAMP SWITCH

Refer to [EC-1946, "Component Inspection \(Stop Lamp Switch\)"](#).

Is the inspection result normal?

YES >> GO TO 7.

NO >> Replace stop lamp switch. Refer to [BR-18, "Exploded View"](#).

## 7. CHECK INTERMITTENT INCIDENT

Refer to [GI-44, "Intermittent Incident"](#).

>> INSPECTION END

## Component Inspection (Stop Lamp Switch)

INFOID:000000007758515

### 1. CHECK STOP LAMP SWITCH-I

1. Turn ignition switch OFF.
2. Disconnect stop lamp switch harness connector.
3. Check the continuity between stop lamp switch terminals under the following conditions.

| Terminals | Condition   |                    | Continuity  |
|-----------|-------------|--------------------|-------------|
| 1 and 2   | Brake pedal | Fully released     | Not existed |
|           |             | Slightly depressed | Existed     |

Is the inspection result normal?

YES >> INSPECTION END

NO >> GO TO 2.

### 2. CHECK STOP LAMP SWITCH-II

1. Adjust stop lamp switch installation. Refer to [BR-7, "Inspection and Adjustment"](#).
2. Check the continuity between stop lamp switch terminals under the following conditions.

| Terminals | Condition   |                    | Continuity  |
|-----------|-------------|--------------------|-------------|
| 1 and 2   | Brake pedal | Fully released     | Not existed |
|           |             | Slightly depressed | Existed     |

Is the inspection result normal?

# P1805 BRAKE SWITCH

[VK56VD FOR MEXICO]

< DTC/CIRCUIT DIAGNOSIS >

YES >> INSPECTION END

NO >> Replace stop lamp switch. Refer to [BR-18, "Exploded View"](#).

A

EC

C

D

E

F

G

H

I

J

K

L

M

N

O

P

# P2100, P2103 THROTTLE CONTROL MOTOR RELAY

< DTC/CIRCUIT DIAGNOSIS >

[VK56VD FOR MEXICO]

## P2100, P2103 THROTTLE CONTROL MOTOR RELAY

### DTC Logic

INFOID:000000007758516

### DTC DETECTION LOGIC

| DTC No. | Trouble diagnosis name<br>(Trouble diagnosis content)                     | DTC detecting condition   | Possible cause  |
|---------|---|---|---|
| P2100   | ETC MOT PWR-B1<br>[Throttle control motor relay<br>circuit open (bank 1)] | ECM detects that the voltage of power<br>source for throttle control motor is ex-<br>cessively low. | <ul style="list-style-type: none"> <li>• Harness or connectors<br/>(Throttle control motor relay circuit is open)</li> <li>• Throttle control motor relay</li> </ul>    |
| P2103   | ETC MOT PWR<br>(Throttle control motor relay<br>circuit short)            | ECM detects that the throttle control<br>motor relay is stuck ON.                                   | <ul style="list-style-type: none"> <li>• Harness or connectors<br/>(Throttle control motor relay circuit is shorted)</li> <li>• Throttle control motor relay</li> </ul> |

### DTC CONFIRMATION PROCEDURE

#### 1. PRECONDITIONING

1. Turn ignition switch OFF and wait at least 10 seconds.
2. Turn ignition switch ON.
3. Turn ignition switch OFF and wait at least 10 seconds.

#### TESTING CONDITION:

Before performing the following procedure, confirm that battery voltage is 8 V or more at idle.

Which DTC is detected?

P2100 >> GO TO 2.

P2103 >> GO TO 3.

#### 2. PERFORM DTC CONFIRMATION PROCEDURE FOR DTC P2100

1. Turn ignition switch ON and wait at least 2 seconds.
2. Start engine and let it idle for 5 seconds.
3. Check DTC.

Is DTC detected?

YES >> Proceed to [EC-1948, "Diagnosis Procedure"](#).

NO >> INSPECTION END

#### 3. PERFORM DTC CONFIRMATION PROCEDURE FOR DTC P2103

1. Turn ignition switch ON and wait at least 1 second.
2. Check DTC.

Is DTC detected?

YES >> Proceed to [EC-1948, "Diagnosis Procedure"](#).

NO >> INSPECTION END

### Diagnosis Procedure

INFOID:000000007758517

#### 1. CHECK THROTTLE CONTROL MOTOR RELAY POWER SUPPLY CIRCUIT

1. Turn ignition switch OFF.
2. Disconnect ECM harness connector.
3. Disconnect IPDM E/R harness connector E7.
4. Check the continuity between IPDM E/R harness connector and ECM harness connector.

| IPDM E/R  |          | ECM       |          | Continuity |
|-----------|----------|-----------|----------|------------|
| Connector | Terminal | Connector | Terminal |            |
| E7        | 71       | M160      | 123      | Existed    |

5. Also check harness for short to ground and short to power.

Is the inspection result normal?

YES >> GO TO 3.

# P2100, P2103 THROTTLE CONTROL MOTOR RELAY

< DTC/CIRCUIT DIAGNOSIS >

[VK56VD FOR MEXICO]

NO >> GO TO 2.

## 2. DETECT MALFUNCTIONING PART

Check the following.

- Harness for open or short between ECM and IPDM E/R
- Loose or poor connection for each connector and harness

>> Repair open circuit, short to ground or short to power in harness or connectors.

## 3. CHECK THROTTLE CONTROL MOTOR RELAY INPUT SIGNAL CIRCUIT

1. Check the continuity between IPDM E/R sensor harness connector and ECM harness connector.

| DTC   | IPDM E/R  |          | ECM       |          | Continuity |
|-------|-----------|----------|-----------|----------|------------|
|       | Connector | Terminal | Connector | Terminal |            |
| P2100 | E5        | 7        | M160      | 173      | Existed    |
| P2103 |           |          |           |          |            |

2. Also check harness for short to ground and short to power.

Is the inspection result normal?

YES >> GO TO 5.

NO >> GO TO 4.

## 4. DETECT MALFUNCTIONING PART

Check the following.

- Harness for open or short between ECM and IPDM E/R
- Loose or poor connection for each connector and harness

>> Repair open circuit, short to ground or short to power in harness or connectors.

## 5. CHECK FUSE

1. Disconnect 15 A fuse (No. 50) from IPDM E/R.
2. Check if 15 A fuse is blown.

Is the inspection result normal?

YES >> GO TO 6.

NO >> Replace 15 A fuse.

## 6. CHECK INTERMITTENT INCIDENT

Refer to [GI-44, "Intermittent Incident"](#).

Is the inspection result normal?

YES >> Replace IPDM E/R. Refer to [PCS-33, "Removal and Installation"](#).

NO >> Repair or replace harness or connectors.

A  
EC  
C  
D  
E  
F  
G  
H  
I  
J  
K  
L  
M  
N  
O  
P

# P2122, P2123 APP SENSOR

< DTC/CIRCUIT DIAGNOSIS >

[VK56VD FOR MEXICO]

## P2122, P2123 APP SENSOR

### DTC Logic

INFOID:000000007758518

#### DTC DETECTION LOGIC

##### NOTE:

If DTC P2122 or P2123 is displayed with DTC P0643, perform the trouble diagnosis for DTC P0643. Refer to [EC-1863, "DTC Logic"](#).

| DTC No. | Trouble diagnosis name<br>(Trouble diagnosis content)                      | DTC detecting condition   | Possible cause  |
|---------|--|---|---|
| P2122   | APP SEN 1/CIRC<br>(Accelerator pedal position sensor 1 circuit low input)  | An excessively low voltage from the APP sensor 1 is sent to ECM.  | <ul style="list-style-type: none"><li>• Harness or connectors (APP sensor 1 circuit is open or shorted.)</li><li>• Accelerator pedal position sensor (APP sensor 1)</li></ul> |
| P2123   | APP SEN 1/CIRC<br>(Accelerator pedal position sensor 1 circuit high input) | An excessively high voltage from the APP sensor 1 is sent to ECM. |   |

#### DTC CONFIRMATION PROCEDURE

##### 1. PRECONDITIONING

1. Turn ignition switch OFF and wait at least 10 seconds.
2. Turn ignition switch ON.
3. Turn ignition switch OFF and wait at least 10 seconds.

##### TESTING CONDITION:

Before performing the following procedure, confirm that battery voltage is 8 V or more at idle.

>> GO TO 2.

##### 2. PERFORM DTC CONFIRMATION PROCEDURE

1. Start engine and let it idle for 1 second.
2. Check DTC.

##### Is DTC detected?

- YES >> Proceed to [EC-1950, "Diagnosis Procedure"](#).  
NO >> INSPECTION END

#### Diagnosis Procedure

INFOID:000000007758519

##### 1. CHECK ACCELERATOR PEDAL POSITION SENSOR 1 POWER SUPPLY CIRCUIT

1. Disconnect accelerator pedal position (APP) sensor harness connector.
2. Turn ignition switch ON.
3. Check the voltage between APP sensor harness connector and ground.

| APP sensor          |          | Ground | Voltage (V) |
|---------------------|----------|--------|-------------|
| Connector           | Terminal |        |             |
| M9<br>(Without ICC) | 5        | Ground | Approx. 5   |
| M153<br>(With ICC)  | 6        |        |             |

##### Is the inspection result normal?

- YES >> GO TO 3.  
NO >> GO TO 2.

##### 2. DETECT MALFUNCTIONING PART

Check the following.

- Harness for open or short between ECM and APP sensor
- Loose or poor connection for each connector and harness

>> Repair open circuit, short to ground or short to power in harness or connectors.

**3.CHECK APP SENSOR 1 GROUND CIRCUIT FOR OPEN AND SHORT**

1. Turn ignition switch OFF.
2. Disconnect ECM harness connector.
3. Check the continuity between APP sensor harness connector and ECM harness connector.

| APP sensor          |          | ECM       |          | Continuity |
|---------------------|----------|-----------|----------|------------|
| Connector           | Terminal | Connector | Terminal |            |
| M9<br>(Without ICC) | 4        | M160      | 140      | Existed    |
| M153<br>(With ICC)  | 5        |           |          |            |

4. Also check harness for short to ground and short to power.

Is the inspection result normal?

- YES >> GO TO 5.  
NO >> GO TO 4.

**4.DETECT MALFUNCTIONING PART**

Check the following.

- Harness for open or short between ECM and APP sensor
- Loose or poor connection for each connector and harness

>> Repair open circuit, short to ground or short to power in harness or connectors.

**5.CHECK APP SENSOR INPUT SIGNAL CIRCUIT FOR OPEN AND SHORT**

1. Check the continuity between APP sensor harness connector and ECM harness connector.

| APP sensor          |          | ECM       |          | Continuity |
|---------------------|----------|-----------|----------|------------|
| Connector           | Terminal | Connector | Terminal |            |
| M9<br>(Without ICC) | 3        | M160      | 136      | Existed    |
| M153<br>(With ICC)  | 4        |           |          |            |

2. Also check harness for short to ground and short to power.

Is the inspection result normal?

- YES >> GO TO 7.  
NO >> GO TO 6.

**6.DETECT MALFUNCTIONING PART**

Check the following.

- Loose or poor connection for each connector and harness
- Harness for open or short between ECM and APP sensor

>> Repair open circuit, short to ground or short to power in harness or connectors.

**7.CHECK APP SENSOR**

Refer to [EC-1952, "Component Inspection \(Accelerator Pedal Position Sensor\)".](#)

Is the inspection result normal?

- YES >> GO TO 9.  
NO >> GO TO 8.

**8.REPLACE ACCELERATOR PEDAL ASSEMBLY**

Replace accelerator pedal assembly.

A  
EC  
C  
D  
E  
F  
G  
H  
I  
J  
K  
L  
M  
N  
O  
P

# P2122, P2123 APP SENSOR

[VK56VD FOR MEXICO]

< DTC/CIRCUIT DIAGNOSIS >

Refer to [ACC-3. "MODELS WITHOUT DISTANCE CONTROL ASSIST SYSTEM : Removal and Installation"](#) (Without distance control assist system).  
Refer to [ACC-4. "MODELS WITH DISTANCE CONTROL ASSIST SYSTEM : Removal and Installation"](#) (With distance control assist system).

>> INSPECTION END

## 9. CHECK INTERMITTENT INCIDENT

Refer to [GI-44. "Intermittent Incident"](#).

>> INSPECTION END

## Component Inspection (Accelerator Pedal Position Sensor)

INFOID:000000007758520

### 1. CHECK ACCELERATOR PEDAL POSITION SENSOR

1. Turn ignition switch OFF.
2. Reconnect all harness connectors disconnected.
3. Turn ignition switch ON.
4. Check the voltage ECM harness connector terminals under the following conditions.

| ECM       |                    |          | Condition       | Voltage (V) |
|-----------|--------------------|----------|-----------------|-------------|
| Connector | +                  | -        |                 |             |
|           | Terminal           | Terminal |                 |             |
| M160      | 136 (APP sensor 1) | 140      | Fully released  | 0.45 - 1.0  |
|           |                    |          | Fully depressed | 4.4 - 4.8   |
|           | 126 (APP sensor 2) | 129      | Fully released  | 0.22 - 0.5  |
|           |                    |          | Fully depressed | 2.1 - 2.5   |

Is the inspection result normal?

- YES >> INSPECTION END  
 NO >> GO TO 2.

### 2. REPLACE ACCELERATOR PEDAL ASSEMBLY

Replace accelerator pedal assembly.  
Refer to [ACC-3. "MODELS WITHOUT DISTANCE CONTROL ASSIST SYSTEM : Removal and Installation"](#) (Without distance control assist system).  
Refer to [ACC-4. "MODELS WITH DISTANCE CONTROL ASSIST SYSTEM : Removal and Installation"](#) (With distance control assist system).

>> INSPECTION END



P2127, P2128 APP SENSOR

DTC Logic

INFOID:000000007758521

DTC DETECTION LOGIC

| DTC No. | Trouble diagnosis name<br>(Trouble diagnosis content)                      | DTC detecting condition   | Possible cause  |
|---------|--|---|---|
| P2127   | APP SEN 2/CIRC<br>(Accelerator pedal position sensor 2 circuit low input)  | An excessively low voltage from the APP sensor 2 is sent to ECM.  | <ul style="list-style-type: none"> <li>• Harness or connectors<br/>(Accelerator pedal position sensor 2 circuit is shorted.)<br/>(Battery current sensor circuit is shorted.)<br/>(Crankshaft position sensor circuit is open or shorted.)<br/>[Camshaft position sensor (bank 1) circuit is shorted.]<br/>(EVAP control system pressure sensor circuit is shorted.)<br/>(Refrigerant pressure sensor circuit is shorted.)</li> <li>• Accelerator pedal position sensor 2</li> <li>• Battery current sensor</li> <li>• Crankshaft position sensor</li> <li>• Camshaft position sensor (bank 1)</li> <li>• EVAP control system pressure sensor</li> <li>• Refrigerant pressure sensor</li> </ul> |
| P2128   | APP SEN 2/CIRC<br>(Accelerator pedal position sensor 2 circuit high input) | An excessively high voltage from the APP sensor 2 is sent to ECM. |   |

DTC CONFIRMATION PROCEDURE

1. PRECONDITIONING

1. Turn ignition switch OFF and wait at least 10 seconds.
2. Turn ignition switch ON.
3. Turn ignition switch OFF and wait at least 10 seconds.

**TESTING CONDITION:**

**Before performing the following procedure, confirm that battery voltage is 8 V or more at idle.**

>> GO TO 2.

2. PERFORM DTC CONFIRMATION PROCEDURE

1. Start engine and let it idle for 1 second.
2. Check DTC.

Is DTC detected?

YES >> Proceed to [EC-1953. "Diagnosis Procedure"](#).

NO >> INSPECTION END

Diagnosis Procedure

INFOID:000000007758522

1. CHECK ACCELERATOR PEDAL POSITION SENSOR 2 POWER SUPPLY CIRCUIT-I

1. Disconnect accelerator pedal position (APP) sensor harness connector.
2. Turn ignition switch ON.
3. Check the voltage between APP sensor harness connector and ground.

| APP sensor          |          | Ground | Voltage (V) |
|---------------------|----------|--------|-------------|
| Connector           | Terminal |        |             |
| M9<br>(Without ICC) | 6        | Ground | Approx. 5 V |
| M153<br>(With ICC)  | 3        |        |             |

Is the inspection result normal?

YES >> GO TO 6.

# P2127, P2128 APP SENSOR

[VK56VD FOR MEXICO]

< DTC/CIRCUIT DIAGNOSIS >

NO >> GO TO 2.

## 2. CHECK APP SENSOR 2 POWER SUPPLY CIRCUIT-II

1. Turn ignition switch OFF.
2. Disconnect ECM harness connector.
3. Check the continuity between APP sensor harness connector and ECM harness connector.

| APP sensor          |          | ECM       |          | Continuity |
|---------------------|----------|-----------|----------|------------|
| Connector           | Terminal | Connector | Terminal |            |
| M9<br>(Without ICC) | 6        | M160      | 131      | Existed    |
| M153<br>(With ICC)  | 3        |           |          |            |

Is the inspection result normal?

YES >> GO TO 4.

NO >> GO TO 3.

## 3. DETECT MALFUNCTIONING PART

Check the following.

- Loose or poor connection for each connector and harness
- Harness for open or short between ECM and APP sensor

>> Repair open circuit.

## 4. CHECK SENSOR POWER SUPPLY CIRCUIT

Check harness for short to power and short to ground, between the following terminals.

| ECM       |          | Sensor                              |           |          |
|-----------|----------|-------------------------------------|-----------|----------|
| Connector | Terminal | Name                                | Connector | Terminal |
| F111      | 76       | CKP sensor                          | F2        | 1        |
|           | 77       | Camshaft position sensor (bank 1)   | F84       | 1        |
| M160      | 133      | Battery current sensor              | E21       | 1        |
|           | 133      | EVAP control system pressure sensor | B73       | 3        |
|           | 133      | Refrigerant pressure sensor         | E77       | 3        |
|           | 131      | APP sensor 2 (Without ICC)          | M9        | 6        |
|           | 131      | APP sensor 2 (With ICC)             | M153      | 3        |

Is the inspection result normal?

YES >> GO TO 5.

NO >> Repair short to ground or short to power in harness or connectors.

## 5. CHECK COMPONENTS

Check the following.

- CKP sensor (Refer to [EC-1826, "Component Inspection \(Crankshaft Position Sensor\)"](#).)
- Camshaft position sensor (bank 1) (Refer to [EC-1831, "Component Inspection \(Camshaft Position Sensor\)"](#).)
- Battery current sensor (Refer to [EC-1906, "Component Inspection \(Battery Current Sensor\)"](#).)
- EVAP control system pressure sensor (Refer to [EC-1974, "Component Inspection \(EVAP Control System Pressure Sensor\)"](#).)
- Refrigerant pressure sensor (Refer to [EC-2001, "Diagnosis Procedure"](#).)

Is the inspection result normal?

YES >> GO TO 12.

NO >> Replace malfunctioning component.

## 6. CHECK APP SENSOR 2 GROUND CIRCUIT FOR OPEN AND SHORT

# P2127, P2128 APP SENSOR

[VK56VD FOR MEXICO]

## < DTC/CIRCUIT DIAGNOSIS >

1. Turn ignition switch OFF.
2. Disconnect ECM harness connector.
3. Check the continuity between APP sensor harness connector and ECM harness connector.

| APP sensor          |          | ECM       |          | Continuity |
|---------------------|----------|-----------|----------|------------|
| Connector           | Terminal | Connector | Terminal |            |
| M9<br>(Without ICC) | 2        | M160      | 129      | Existed    |
| M153<br>(With ICC)  | 2        |           |          |            |

4. Also check harness for short to ground and short to power.

Is the inspection result normal?

YES >> GO TO 8.

NO >> GO TO 7.

## 7. DETECT MALFUNCTIONING PART

Check the following.

- Loose or poor connection for each connector and harness
- Harness for open or short between ECM and APP sensor

>> Repair open circuit, short to ground or short to power in harness or connectors.

## 8. CHECK APP SENSOR 2 INPUT SIGNAL CIRCUIT FOR OPEN AND SHORT

1. Check the continuity between APP sensor harness connector and ECM harness connector.

| APP sensor          |          | ECM       |          | Continuity |
|---------------------|----------|-----------|----------|------------|
| Connector           | Terminal | Connector | Terminal |            |
| M9<br>(Without ICC) | 1        | M160      | 126      | Existed    |
| M153<br>(With ICC)  | 1        |           |          |            |

2. Also check harness for short to ground and short to power.

Is the inspection result normal?

YES >> GO TO 10.

NO >> GO TO 9.

## 9. DETECT MALFUNCTIONING PART

Check the following.

- Harness for open or short between ECM and APP sensor
- Loose or poor connection for each connector and harness

>> Repair open circuit, short to ground or short to power in harness or connectors.

## 10. CHECK APP SENSOR

Refer to [EC-1960, "Component Inspection \(Accelerator Pedal Position Sensor\)"](#).

Is the inspection result normal?

YES >> GO TO 12.

NO >> GO TO 11.

## 11. REPLACE ACCELERATOR PEDAL ASSEMBLY

Replace accelerator pedal assembly.

Refer to [ACC-3, "MODELS WITHOUT DISTANCE CONTROL ASSIST SYSTEM : Removal and Installation"](#) (Without distance control assist system).

Refer to [ACC-4, "MODELS WITH DISTANCE CONTROL ASSIST SYSTEM : Removal and Installation"](#) (With distance control assist system).

>> INSPECTION END

**12.CHECK INTERMITTENT INCIDENT**

Refer to [GI-44. "Intermittent Incident"](#).

>> INSPECTION END

**Component Inspection (Accelerator Pedal Position Sensor)**

INFOID:000000007758523

**1.CHECK ACCELERATOR PEDAL POSITION SENSOR**

1. Turn ignition switch OFF.
2. Reconnect all harness connectors disconnected.
3. Turn ignition switch ON.
4. Check the voltage ECM harness connector terminals under the following conditions.

| Connector | ECM                |          | Condition       | Voltage (V) |
|-----------|--------------------|----------|-----------------|-------------|
|           | +                  | -        |                 |             |
|           | Terminal           | Terminal |                 |             |
| M160      | 136 (APP sensor 1) | 140      | Fully released  | 0.45 - 1.0  |
|           |                    |          | Fully depressed | 4.4 - 4.8   |
|           | 126 (APP sensor 2) | 129      | Fully released  | 0.22 - 0.5  |
|           |                    |          | Fully depressed | 2.1 - 2.5   |

Is the inspection result normal?

YES >> INSPECTION END

NO >> GO TO 2.

**2.REPLACE ACCELERATOR PEDAL ASSEMBLY**

Replace accelerator pedal assembly.

Refer to [ACC-3. "MODELS WITHOUT DISTANCE CONTROL ASSIST SYSTEM : Removal and Installation"](#) (Without distance control assist system).

Refer to [ACC-4. "MODELS WITH DISTANCE CONTROL ASSIST SYSTEM : Removal and Installation"](#) (With distance control assist system).

>> INSPECTION END

P2138 APP SENSOR

DTC Logic

INFOID:000000007758524

DTC DETECTION LOGIC

NOTE:

If DTC P2138 is displayed with DTC P0643, first perform the trouble diagnosis for DTC P0643. Refer to [EC-1863, "DTC Logic"](#).

| DTC No. | Trouble diagnosis name<br>(Trouble diagnosis content)                       | DTC detecting condition   | Possible cause   |
|---------|---|---|--|
| P2138   | APP SENSOR<br>(Accelerator pedal position sensor circuit range/performance) | Rationally incorrect voltage is sent to ECM compared with the signals from APP sensor 1 and APP sensor 2. | <ul style="list-style-type: none"> <li>• Harness or connectors<br/>(APP sensor 1 or 2 circuit is open or shorted.)<br/>(Battery current sensor circuit is shorted.)<br/>(Crankshaft position sensor circuit is open or shorted.)<br/>[Camshaft position sensor (bank 1) circuit is shorted.]<br/>(EVAP control system pressure sensor circuit is shorted.)</li> <li>• (Refrigerant pressure sensor circuit is shorted.)</li> <li>• Accelerator pedal position sensor (APP sensor 1 or 2)</li> <li>• Battery current sensor</li> <li>• Crankshaft position sensor</li> <li>• Camshaft position sensor (bank 1)</li> <li>• EVAP control system pressure sensor</li> <li>• Refrigerant pressure sensor</li> </ul> |

DTC CONFIRMATION PROCEDURE

1. PRECONDITIONING

1. Turn ignition switch OFF and wait at least 10 seconds.
2. Turn ignition switch ON.
3. Turn ignition switch OFF and wait at least 10 seconds.

TESTING CONDITION:

Before performing the following procedure, confirm that battery voltage is 8 V or more at idle.

>> GO TO 2.

2. PERFORM DTC CONFIRMATION PROCEDURE

1. Start engine and let it idle for 1 second.
2. Check DTC.

Is DTC detected?

YES >> Proceed to [EC-1957, "Diagnosis Procedure"](#).

NO >> INSPECTION END

Diagnosis Procedure

INFOID:000000007758525

1. CHECK ACCELERATOR PEDAL POSITION SENSOR 1 POWER SUPPLY CIRCUIT

1. Disconnect accelerator pedal position (APP) sensor harness connector.
2. Turn ignition switch ON.
3. Check the voltage between APP sensor harness connector and ground.

| APP sensor          |          | Ground | Voltage (V) |
|---------------------|----------|--------|-------------|
| Connector           | Terminal |        |             |
| M9<br>(Without ICC) | 5        | Ground | Approx. 5   |
| M153<br>(With ICC)  | 6        |        |             |

Is the inspection result normal?

# P2138 APP SENSOR

[VK56VD FOR MEXICO]

## < DTC/CIRCUIT DIAGNOSIS >

- YES >> GO TO 3.
- NO >> GO TO 2.

### 2. DETECT MALFUNCTIONING PART

Check the following.

- Loose or poor connection for each connector and harness
- Harness for open or short between ECM and APP sensor

>> Repair open circuit, short to ground or short to power in harness or connectors.

### 3. CHECK APP SENSOR 2 POWER SUPPLY CIRCUIT-I

1. Turn ignition switch ON.
2. Check the voltage between APP sensor harness connector and ground.

| APP sensor          |          | Ground | Voltage (V) |
|---------------------|----------|--------|-------------|
| Connector           | Terminal |        |             |
| M9<br>(Without ICC) | 6        | Ground | Approx. 5   |
| M153<br>(With ICC)  | 3        |        |             |

Is the inspection result normal?

- YES >> GO TO 8.
- NO >> GO TO 4.

### 4. CHECK APP SENSOR 2 POWER SUPPLY CIRCUIT-II

1. Turn ignition switch OFF.
2. Disconnect ECM harness connector.
3. Check the continuity between APP sensor harness connector and ECM harness connector.

| APP sensor          |          | ECM       |          | Continuity |
|---------------------|----------|-----------|----------|------------|
| Connector           | Terminal | Connector | Terminal |            |
| M9<br>(Without ICC) | 6        | M160      | 131      | Existed    |
| M153<br>(With ICC)  | 3        |           |          |            |

Is the inspection result normal?

- YES >> GO TO 6.
- NO >> GO TO 5.

### 5. DETECT MALFUNCTIONING PART

Check the following.

- Harness for open or short between ECM and accelerator pedal position sensor
- Loose or poor connection for each connector and harness

>> Repair open circuit.

### 6. CHECK SENSOR POWER SUPPLY CIRCUIT

Check harness for short to power and short to ground, between the following terminals.

| ECM       |          | Sensor                            |           |          |
|-----------|----------|-----------------------------------|-----------|----------|
| Connector | Terminal | Name                              | Connector | Terminal |
| F111      | 76       | CKP sensor                        | F2        | 1        |
|           | 77       | Camshaft position sensor (bank 1) | F84       | 1        |

# P2138 APP SENSOR

< DTC/CIRCUIT DIAGNOSIS >

[VK56VD FOR MEXICO]

| ECM       |          | Sensor                              |           |          |
|-----------|----------|-------------------------------------|-----------|----------|
| Connector | Terminal | Name                                | Connector | Terminal |
| M160      | 133      | Battery current sensor              | E21       | 1        |
|           | 133      | EVAP control system pressure sensor | B73       | 3        |
|           | 133      | Refrigerant pressure sensor         | E77       | 3        |
|           | 137      | APP sensor 1 (Without ICC)          | M9        | 5        |
|           | 137      | APP sensor 1 (With ICC)             | M153      | 6        |
|           | 131      | APP sensor 2 (Without ICC)          | M9        | 6        |
|           | 131      | APP sensor 2 (With ICC)             | M153      | 3        |

Is the inspection result normal?

YES >> GO TO 7.

NO >> Repair short to ground or short to power in harness or connectors.

## 7. CHECK COMPONENTS

Check the following.

- CKP sensor (Refer to [EC-1826, "Component Inspection \(Crankshaft Position Sensor\)"](#).)
- Camshaft position sensor (bank 1) (Refer to [EC-1831, "Component Inspection \(Camshaft Position Sensor\)"](#).)
- Battery current sensor (Refer to [EC-1906, "Component Inspection \(Battery Current Sensor\)"](#).)
- EVAP control system pressure sensor (Refer to [EC-1974, "Component Inspection \(EVAP Control System Pressure Sensor\)"](#).)
- Refrigerant pressure sensor (Refer to [EC-2001, "Diagnosis Procedure"](#).)

Is the inspection result normal?

YES >> GO TO 14.

NO >> Replace malfunctioning component.

## 8. CHECK APP SENSOR GROUND CIRCUIT FOR OPEN AND SHORT

1. Turn ignition switch OFF.
2. Disconnect ECM harness connector.
3. Check the continuity between APP sensor harness connector and ECM harness connector.

| APP sensor          |          | ECM       |          | Continuity |
|---------------------|----------|-----------|----------|------------|
| Connector           | Terminal | Connector | Terminal |            |
| M9<br>(Without ICC) | 4        | M160      | 140      | Existed    |
|                     | 2        |           | 129      |            |
| M153<br>(With ICC)  | 5        | M160      | 140      | Existed    |
|                     | 2        |           | 129      |            |

4. Also check harness for short to ground and short to power.

Is the inspection result normal?

YES >> GO TO 10.

NO >> GO TO 9.

## 9. DETECT MALFUNCTIONING PART

Check the following.

- Harness for open or short between ECM and accelerator pedal position sensor
- Loose or poor connection for each connector and harness

>> Repair open circuit, short to ground or short to power in harness or connectors.

## 10. CHECK APP SENSOR INPUT SIGNAL CIRCUIT FOR OPEN AND SHORT

1. Check the continuity between APP sensor harness connector and ECM harness connector.

< DTC/CIRCUIT DIAGNOSIS >

| APP sensor          |          | ECM       |          | Continuity |
|---------------------|----------|-----------|----------|------------|
| Connector           | Terminal | Connector | Terminal |            |
| M9<br>(Without ICC) | 3        | M160      | 136      | Existed    |
|                     | 1        |           | 126      |            |
| M153<br>(With ICC)  | 4        | M160      | 136      | Existed    |
|                     | 1        |           | 126      |            |

2. Also check harness for short to ground and short to power.

Is the inspection result normal?

YES >> GO TO 12.

NO >> GO TO 11.

## 11. DETECT MALFUNCTIONING PART

Check the following.

- Harness for open or short between ECM and accelerator pedal position sensor
- Loose or poor connection for each connector and harness

>> Repair open circuit, short to ground or short to power in harness or connectors.

## 12. CHECK APP SENSOR

Refer to [EC-1960, "Component Inspection \(Accelerator Pedal Position Sensor\)"](#).

Is the inspection result normal?

YES >> GO TO 14.

NO >> GO TO 13.

## 13. REPLACE ACCELERATOR PEDAL ASSEMBLY

Replace accelerator pedal assembly.

Refer to [ACC-3, "MODELS WITHOUT DISTANCE CONTROL ASSIST SYSTEM : Removal and Installation"](#) (Without distance control assist system).

Refer to [ACC-4, "MODELS WITH DISTANCE CONTROL ASSIST SYSTEM : Removal and Installation"](#) (With distance control assist system).

>> INSPECTION END

## 14. CHECK INTERMITTENT INCIDENT

Refer to [GI-44, "Intermittent Incident"](#).

>> INSPECTION END

## Component Inspection (Accelerator Pedal Position Sensor)

INFOID:000000007758526

### 1. CHECK ACCELERATOR PEDAL POSITION SENSOR

1. Turn ignition switch OFF.
2. Reconnect all harness connectors disconnected.
3. Turn ignition switch ON.
4. Check the voltage ECM harness connector terminals under the following conditions.



# P2138 APP SENSOR

< DTC/CIRCUIT DIAGNOSIS >

[VK56VD FOR MEXICO]

| ECM       |                    |          | Condition       | Voltage (V) |
|-----------|--------------------|----------|-----------------|-------------|
| Connector | +                  | -        |                 |             |
|           |                    | Terminal | Terminal        |             |
| M160      | 136 (APP sensor 1) | 140      | Fully released  | 0.45 - 1.0  |
|           |                    |          | Fully depressed | 4.4 - 4.8   |
|           | 126 (APP sensor 2) | 129      | Fully released  | 0.22 - 0.5  |
|           |                    |          | Fully depressed | 2.1 - 2.5   |

Is the inspection result normal?

YES >> INSPECTION END

NO >> GO TO 2.

## 2. REPLACE ACCELERATOR PEDAL ASSEMBLY

Replace accelerator pedal assembly.

Refer to [ACC-3. "MODELS WITHOUT DISTANCE CONTROL ASSIST SYSTEM : Removal and Installation"](#) (Without distance control assist system).

Refer to [ACC-4. "MODELS WITH DISTANCE CONTROL ASSIST SYSTEM : Removal and Installation"](#) (With distance control assist system).

>> INSPECTION END

A  
EC  
C  
D  
E  
F  
G  
H  
I  
J  
K  
L  
M  
N  
O  
P

# P2539 LOW FUEL PRESSURE SENSOR

< DTC/CIRCUIT DIAGNOSIS >

[VK56VD FOR MEXICO]

## P2539 LOW FUEL PRESSURE SENSOR

### DTC Logic

INFOID:000000007758527

### DTC DETECTION LOGIC

| DTC No. | Trouble diagnosis name<br>(Trouble diagnosis content)                                    | DTC detecting condition   | Possible cause  |
|---------|--|---|---|
| P2539   | LOW FUEL PRES SEN<br>(Low fuel pressure sensor<br>circuit low input and high in-<br>put) | Signal voltage from the low fuel pressure<br>sensor remains at more than 4.84 V / less<br>than 0.3 V for 5 seconds or more. | <ul style="list-style-type: none"><li>• Harness or connectors<br/>(Low fuel pressure sensor circuit is open<br/>or shorted.)<br/>(Power steering pressure sensor circuit is<br/>open or shorted.)<br/>(EOP sensor circuit is open or shorted.)<br/>(FRP sensor circuit is open or shorted.)</li><li>• Low fuel pressure sensor</li><li>• Power steering pressure sensor</li><li>• EOP sensor</li><li>• FRP sensor</li></ul> |

### DTC CONFIRMATION PROCEDURE

#### 1. PRECONDITIONING

If DTC Confirmation Procedure has been previously conducted, always perform the following procedure before conducting the next test.

1. Turn ignition switch OFF and wait at least 10 seconds.
2. Turn ignition switch ON.
3. Turn ignition switch OFF and wait at least 10 seconds.

#### TESTING CONDITION:

Before performing the following procedure, confirm that battery voltage is 11 V or more at idle.

>> GO TO 2.

#### 2. PERFORM DTC CONFIRMATION PROCEDURE

1. Start engine and let it idle for at least 60 seconds.
2. Check 1st trip DTC.

Is 1st trip DTC detected?

- YES >> Proceed to [EC-1962, "Diagnosis Procedure"](#).  
NO >> INSPECTION END

### Diagnosis Procedure

INFOID:000000007758528

#### 1. CHECK LOW FUEL PRESSURE SENSOR POWER SUPPLY-I

1. Turn ignition switch OFF.
2. Disconnect low fuel pressure sensor connector.
3. Turn ignition switch ON.
4. Check the voltage between low fuel pressure sensor harness connector terminals.

| Low fuel pressure sensor |          |   | Voltage<br>(Approx.) |
|--------------------------|----------|---|----------------------|
| Connector                | +        | - |                      |
|                          | terminal |   |                      |
| F39                      | 3        | 1 | 5 V                  |

Inspection result normal?

- YES >> GO TO 6.  
NO >> GO TO 2.

#### 2. CHECK LOW FUEL PRESSURE SENSOR POWER SUPPLY-II

## P2539 LOW FUEL PRESSURE SENSOR

< DTC/CIRCUIT DIAGNOSIS >

[VK56VD FOR MEXICO]

Check the voltage between low fuel pressure sensor harness connector and the ground.

| +                        |          | -      | Voltage<br>(Approx.) |
|--------------------------|----------|--------|----------------------|
| Low fuel pressure sensor |          |        |                      |
| Connector                | Terminal |        |                      |
| F39                      | 3        | Ground | 5 V                  |

Is inspection result normal?

YES >> GO TO 4.

NO >> GO TO 3.

### 3. CHECK SENSOR POWER SUPPLY CIRCUIT

1. Turn ignition switch OFF.
2. Disconnect ECM harness connector.
3. Check harness connector for short to power and short to ground, between the following terminals.

| ECM       |          | Sensor                         |           |          |
|-----------|----------|--------------------------------|-----------|----------|
| Connector | Terminal | Name                           | Connector | Terminal |
| F110      | 27       | Power steering pressure sensor | F35       | 3        |
|           |          | Low fuel pressure sensor       | F39       | 3        |
|           | 28       | FRP sensor                     | F6        | 1        |
|           |          | Engine oil pressure sensor     | F32       | 3        |

Is inspection result normal?

YES >> Perform the trouble diagnosis for power supply circuit. Refer to [EC-1707. "Diagnosis Procedure"](#).

NO >> Repair or replace error-detected parts.

### 4. CHECK LOW FUEL PRESSURE SENSOR GROUND CIRCUIT

1. Turn ignition switch OFF.
2. Disconnect ECM harness connector.
3. Check the continuity between low fuel pressure sensor harness connector and ECM harness connector.

| +                        |          | -         |          | Continuity |
|--------------------------|----------|-----------|----------|------------|
| Low fuel pressure sensor |          | ECM       |          |            |
| Connector                | Terminal | Connector | Terminal |            |
| F39                      | 1        | F110      | 27       | Existed    |

Is inspection result normal?

YES >> GO TO 5.

NO >> Repair or replace error-detected parts.

### 5. CHECK ECM GROUND CIRCUIT

1. Turn ignition switch OFF.
2. Disconnect ECM harness connector.
3. Check the continuity between ECM harness connector and the ground.

| ECM       |          | Ground | Continuity |
|-----------|----------|--------|------------|
| Connector | Terminal |        |            |
| F110      | 10       | Ground | Existed    |
| M160      | 114      |        |            |
|           | 115      |        |            |
|           | 174      |        |            |
|           | 175      |        |            |

Is inspection result normal?

# P2539 LOW FUEL PRESSURE SENSOR

< DTC/CIRCUIT DIAGNOSIS >

[VK56VD FOR MEXICO]

YES >> Check intermittent incident. Refer to [GI-44, "Intermittent Incident"](#).

NO >> Repair or replace error-detected parts.

## 6. CHECK LOW FUEL PRESSURE SENSOR SIGNAL CIRCUIT

1. Turn ignition switch OFF.
2. Disconnect ECM harness connector.
3. Check the continuity between low fuel pressure sensor harness connector and ECM harness connector.

| +                        |          | -         |          | Continuity |
|--------------------------|----------|-----------|----------|------------|
| Low fuel pressure sensor |          | ECM       |          |            |
| Connector                | Terminal | Connector | Terminal |            |
| F39                      | 2        | F110      | 23       | Existed    |

4. Also check harness for short to ground and to power.

Is inspection result normal?

YES >> GO TO 7.

NO >> Repair or replace error-detected parts.

## 7. CHECK LOW FUEL PRESSURE SENSOR

Refer to [EC-1964, "Component Inspection"](#).

Is inspection result normal?

YES >> Check intermittent incident. Refer to [GI-44, "Intermittent Incident"](#).

NO >> Replace low fuel pressure sensor.

## Component Inspection

INFOID:000000007758529

## 1. CHECK LOW FUEL PRESSURE SENSOR

### WITH CONSULT

1. Turn ignition switch OFF.
2. Reconnect harness connector disconnected.
3. Start the engine.
4. Select "DATA MONITOR" mode with CONSULT.
5. Check that the "L/FUEL PRES SEN V" value.

| Data monitor item | Condition                         | Value (Approx.) |
|-------------------|-----------------------------------|-----------------|
| L/FUEL PRES SEN V | Engine speed: idle                | 3,000 –3,300 mV |
|                   | Engine speed: 3,000 rpm (no load) |                 |

### WITHOUT CONSULT

1. Turn ignition switch OFF.
2. Reconnect harness connector disconnected.
3. Start the engine.
4. Check low fuel pressure sensor signal voltage.

# P2539 LOW FUEL PRESSURE SENSOR

< DTC/CIRCUIT DIAGNOSIS >

[VK56VD FOR MEXICO]

| +                        |          | -      | Condition   | Value<br>(Approx.) |
|--------------------------|----------|--------|---|--------------------|
| Low fuel pressure sensor |          | Ground |   |                    |
| Connector                | Terminal |        |   |                    |
| F39                      | 2        | Ground | [Engine is running]<br>• Warm-up condition<br>• Idle speed              |                    |
|                          |          |        | [Engine is running]<br>• Warm-up condition<br>• Engine speed: 2,000 rpm |                    |

Is the inspection result normal?

YES >> INSPECTION END.

NO >> Replace low fuel pressure sensor.

A  
EC  
C  
D  
E  
F  
G  
H  
I  
J  
K  
L  
M  
N  
O  
P

COOLING FAN

Description

INFOID:000000007758537

COOLING FAN CONTROL MODULE

Cooling fan control module receives ON/OFF pulse duty signal from IPDM E/R. Corresponding to this ON/OFF pulse duty signal, cooling fan control module sends cooling fan motor operating voltage to cooling fan motor. The revolution speed of cooling fan motor is controlled by duty cycle of the voltage.

COOLING FAN MOTOR

Cooling fan motor receives cooling fan motor operating voltage from cooling fan control module. The revolution speed of cooling fan motor is controlled by duty cycle of the voltage.

Component Function Check

INFOID:000000007758538

1. CHECK COOLING FAN FUNCTION

Ⓟ WITH CONSULT

1. Turn ignition switch ON.
2. Perform "FAN DUTY CONTROL" in "ACTIVE TEST" mode with CONSULT.
3. Check that cooling fan speed varies according to the percentage.

ⓧ WITHOUT CONSULT

1. Perform IPDM E/R auto active test and check cooling fan motors operation, refer to [PCS-12, "Diagnosis Description"](#).
2. Check that cooling fan operates.

Is the inspection result normal?

- YES >> INSPECTION END  
 NO >> Proceed to [EC-1966, "Diagnosis Procedure"](#).

Diagnosis Procedure

INFOID:000000007758539

1. CHECK COOLING FAN CONTROL MODULE POWER SUPPLY CIRCUIT-I

1. Turn ignition switch OFF.
2. Disconnect cooling fan control module harness connectors E37, E38.
3. Turn ignition switch ON.
4. Check the voltage between cooling fan control module harness connector and ground.

| Cooling fan control module            |          | Ground | Voltage         |
|---------------------------------------|----------|--------|-----------------|
| Connector                             | Terminal |        |                 |
| E37<br>(Cooling fan control module 1) | 3        | Ground | Battery voltage |
| E39<br>(Cooling fan control module 2) | 3        |        |                 |

Is the inspection result normal?

- YES >> GO TO 2.  
 NO >> GO TO 7.

2. CHECK COOLING FAN CONTROL MODULE GROUND CIRCUIT

1. Turn ignition switch OFF.
2. Check the continuity between cooling fan control module harness connector and ground.

# COOLING FAN

< DTC/CIRCUIT DIAGNOSIS >

[VK56VD FOR MEXICO]

| Cooling fan control module            |          | Ground | Continuity |
|---------------------------------------|----------|--------|------------|
| Connector                             | Terminal |        |            |
| E37<br>(Cooling fan control module 1) | 1        | Ground | Existed    |
| E39<br>(Cooling fan control module 2) | 1        |        |            |

3. Also check harness for short to power.

Is the inspection result normal?

YES >> GO TO 3.

NO >> Repair open circuit or short to power in harness or connectors.

## 3.CHECK IPDM E/R GROUND CIRCUIT

1. Disconnect IPDM E/R harness connectors E5, E6.
2. Check the continuity between IPDM E/R harness connector and ground.

| IPDM E/R  |          | Ground | Continuity |
|-----------|----------|--------|------------|
| Connector | Terminal |        |            |
| E5        | 11       | Ground | Existed    |
| E6        | 41       |        |            |

3. Also check harness for short to power.

Is the inspection result normal?

YES >> GO TO 4.

NO >> Repair open circuit or short to power in harness or connectors.

## 4.CHECK COOLING FAN CONTROL SIGNAL CIRCUIT

1. Disconnect IPDM E/R harness connector E9.
2. Check the continuity between IPDM E/R harness connector and cooling fan control module harness connector.

| IPDM E/R  |          | Cooling fan control module            |          | Continuity |
|-----------|----------|---------------------------------------|----------|------------|
| Connector | Terminal | Connector                             | Terminal |            |
| E9        | 97       | E37<br>(Cooling fan control module 1) | 2        | Existed    |
|           |          | E39<br>(Cooling fan control module 2) | 2        | Existed    |

3. Also check harness for short to ground and short to power.

Is the inspection result normal?

YES >> GO TO 5.

NO >> Repair open circuit, short to ground or short to power in harness or connectors.

## 5.CHECK COOLING FAN CONTROL MODULE OUTPUT SIGNAL CIRCUIT

1. Reconnect all harness connectors disconnected.
2. Disconnect cooling fan control module harness connectors E301, E303.
3. Turn ignition switch ON.
4. Check the voltage between cooling fan control module terminals and ground.

| Cooling fan control module            |          | Ground | Voltage         |
|---------------------------------------|----------|--------|-----------------|
| Connector                             | Terminal |        |                 |
| E37<br>(Cooling fan control module 1) | 4        | Ground | Battery voltage |
| E39<br>(Cooling fan control module 2) | 6        |        |                 |

# COOLING FAN

[VK56VD FOR MEXICO]

< DTC/CIRCUIT DIAGNOSIS >

Is the inspection result normal?

- YES >> GO TO 6.  
NO >> Replace malfunctioning cooling fan control module.

## 6.CHECK COOLING FAN MOTORS -1 AND -2

Refer to [EC-1969. "Component Inspection \(Cooling Fan Motor\)".](#)

Is the inspection result normal?

- YES >> GO TO 11.  
NO >> Replace malfunctioning cooling fan motor. Refer to [CO-44. "Removal and Installation".](#)

## 7.CHECK COOLING FAN CONTROL MODULE POWER SUPPLY CIRCUIT-II

1. Turn ignition switch OFF.
2. Disconnect cooling fan relay-1 and cooling fan relay-2.
3. Check the voltage between cooling fan relay harness connector and ground.

| Cooling fan relay            |          | Ground | Voltage         |
|------------------------------|----------|--------|-----------------|
| Connector                    | Terminal |        |                 |
| E17<br>(Cooling fan relay-1) | 3        | Ground | Battery voltage |
| E19<br>(Cooling fan relay-2) | 3        |        |                 |

4. Turn ignition switch ON.
5. Check the voltage between cooling fan relay harness connector and ground.

| Cooling fan relay            |          | Ground | Voltage         |
|------------------------------|----------|--------|-----------------|
| Connector                    | Terminal |        |                 |
| E17<br>(Cooling fan relay-1) | 2        | Ground | Battery voltage |

Is the inspection result normal?

- YES >> GO TO 9.  
NO >> GO TO 8.

## 8.DETECT MALFUNCTIONING PART

Check the following.

- 10 A fuse (No. 42)
- 50 A fusible link (letter O)
- 50 A fusible link (letter R)
- IPDM E/R harness connector E7
- Harness for open or short between cooling fan relay and fuse
- Harness for open or short between cooling fan relay and battery

>> Repair open circuit, short to ground or short to power in harness or connectors.

## 9.CHECK COOLING FAN CONTROL MODULE POWER SUPPLY CIRCUIT-III

1. Turn ignition switch OFF.
2. Disconnect IPDM E/R harness connector E6.
3. Check the continuity between cooling fan relay harness connector and IPDM E/R harness connector.

| Cooling fan relay            |          | IPDM E/R  |          | Continuity |
|------------------------------|----------|-----------|----------|------------|
| Connector                    | Terminal | Connector | Terminal |            |
| E17<br>(Cooling fan relay-1) | 1        | E6        | 42       | Existed    |

4. Check the continuity between cooling fan relay harness connector and cooling fan control module harness connector.



# COOLING FAN

< DTC/CIRCUIT DIAGNOSIS >

[VK56VD FOR MEXICO]

| Cooling fan relay            |          | Cooling fan control module            |          | Continuity |
|------------------------------|----------|---------------------------------------|----------|------------|
| Connector                    | Terminal | Connector                             | Terminal |            |
| E17<br>(Cooling fan relay-1) | 5        | E37<br>(Cooling fan control module-1) | 3        | Existed    |
| E19<br>(Cooling fan relay-2) | 5        | E39<br>(Cooling fan control module-2) | 3        | Existed    |

5. Check the continuity between cooling fan relay-1 harness connector and cooling fan relay-2 harness connector.

| Cooling fan relay            |          |                              |          | Continuity |
|------------------------------|----------|------------------------------|----------|------------|
| Connector                    | Terminal | Connector                    | Terminal |            |
| E17<br>(Cooling fan relay-1) | 5        | E19<br>(Cooling fan relay-2) | 2        | Existed    |

6. Check the continuity between cooling fan relay-2 harness connector and ground.

| Cooling fan relay            |          | Ground | Continuity |
|------------------------------|----------|--------|------------|
| Connector                    | Terminal |        |            |
| E17<br>(Cooling fan relay-1) | 1        | Ground | Existed    |

7. Also check harness for short to ground and short to power.

Is the inspection result normal?

YES >> GO TO 10.

NO >> Repair open circuit, short to ground or short to power in harness or connectors.

## 10. CHECK COOLING FAN RELAYS -1 AND -2

Refer to [EC-1970. "Component Inspection \(Cooling Fan Relay\)".](#)

Is the inspection result normal?

YES >> GO TO 11.

NO >> Replace malfunctioning cooling fan relay.

## 11. CHECK INTERMITTENT INCIDENT

Perform [GI-44. "Intermittent Incident".](#)

Is the inspection result normal?

YES >> Replace IPDM E/R. Refer to [PCS-33. "Removal and Installation".](#)

NO >> Repair or replace harness connectors.

## Component Inspection (Cooling Fan Motor)

INFOID:000000007758540

### 1. CHECK COOLING FAN MOTOR

1. Turn ignition switch OFF.
2. Disconnect cooling fan control module harness connectors E301, E303.
3. Supply cooling fan control module harness connector terminals with battery voltage as per the following, and check operation.

| Cooling fan control module |           |          |     | Operation             |
|----------------------------|-----------|----------|-----|-----------------------|
| Motor                      | Connector | Terminal |     |                       |
|                            |           | (+)      | (-) |                       |
| 1                          | E301      | 4        | 5   | Cooling fan operates. |
| 2                          | E303      | 6        | 7   |                       |

Is the inspection result normal?

YES >> INSPECTION END

# COOLING FAN

[VK56VD FOR MEXICO]

< DTC/CIRCUIT DIAGNOSIS >

NO >> Replace malfunctioning cooling fan motor.

## Component Inspection (Cooling Fan Relay)

INFOID:000000007758541

### 1. CHECK COOLING FAN RELAY

1. Turn ignition switch OFF.
2. Remove cooling fan relay.
3. Check the continuity between cooling fan relay terminals under the following conditions.

| Terminals | Conditions   | Continuity  |
|-----------|--|-------------|
| 3 and 5   | 12 V direct current supply between terminals 1 and 2 | Existed     |
|           | No current supply                                    | Not existed |

Is the inspection result normal?

- YES >> INSPECTION END  
NO >> Replace cooling fan relay.

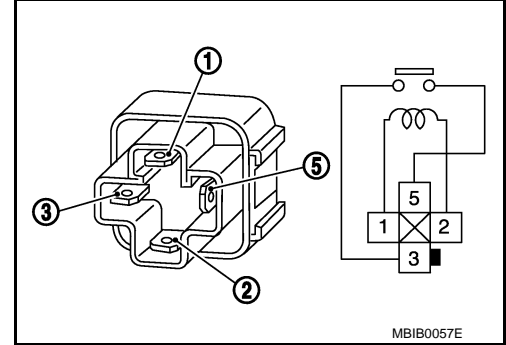

## ELECTRICAL LOAD SIGNAL

## Description

INFOID:000000007758542

The electrical load signal (Rear window defogger switch signal, headlamp switch signal, blower fan switch signal, etc.) is transferred via the CAN communication line.

## Component Function Check

INFOID:000000007758543

## 1.CHECK REAR WINDOW DEFOGGER SWITCH FUNCTION

1. Turn ignition switch ON.
2. Select "DATA MONITOR" mode with CONSULT.
3. Select "LOAD SIGNAL" and check indication under the following conditions.

| Monitor item | Condition                   |     | Indication |
|--------------|-----------------------------|-----|------------|
| LOAD SIGNAL  | Rear window defogger switch | ON  | ON         |
|              |                             | OFF | OFF        |

Is the inspection result normal?

YES >> GO TO 2.

NO >> Proceed to [EC-1971, "Diagnosis Procedure"](#).

## 2.CHECK LIGHTING SWITCH FUNCTION

Check "LOAD SIGNAL" indication under the following conditions.

| Monitor item | Condition       |                    | Indication |
|--------------|-----------------|--------------------|------------|
| LOAD SIGNAL  | Lighting switch | ON at 2nd position | ON         |
|              |                 | OFF                | OFF        |

Is the inspection result normal?

YES >> GO TO 3.

NO >> Proceed to [EC-1971, "Diagnosis Procedure"](#).

## 3.CHECK BLOWER FAN CONTROL SWITCH FUNCTION

Select "HEATER FAN SW" and check indication under the following conditions.

| Monitor item  | Condition                 |     | Indication |
|---------------|---------------------------|-----|------------|
| HEATER FAN SW | Blower fan control switch | ON  | ON         |
|               |                           | OFF | OFF        |

Is the inspection result normal?

YES >> INSPECTION END

NO >> Proceed to [EC-1971, "Diagnosis Procedure"](#).

## Diagnosis Procedure

INFOID:000000007758544

## 1.INSPECTION START

Confirm the malfunctioning circuit (rear window defogger, headlamp or blower fan). Refer to [EC-1971, "Component Function Check"](#).

Which circuit is related to the incident?

Rear window defogger>>GO TO 2.

Headlamp>>GO TO 3.

Heater fan>>GO TO 4.

## 2.CHECK REAR WINDOW DEFOGGER SYSTEM

Refer to [DEF-11, "Work Flow"](#).

## ELECTRICAL LOAD SIGNAL

< DTC/CIRCUIT DIAGNOSIS >

[VK56VD FOR MEXICO]

---

>> INSPECTION END

### 3.CHECK HEADLAMP SYSTEM

---

Refer to [EXL-49, "Work Flow"](#).

>> INSPECTION END

### 4.CHECK BLOWER FAN CONTROL SYSTEM

---

Refer to [HAC-68, "Work Flow"](#).

>> INSPECTION END

# EVAP CONTROL SYSTEM PRESSURE SENSOR

< DTC/CIRCUIT DIAGNOSIS >

[VK56VD FOR MEXICO]

## EVAP CONTROL SYSTEM PRESSURE SENSOR

### Component Function Check

INFOID:000000007801182

#### 1. CHECK EVAP CONTROL SYSTEM PRESSURE SENSOR FUNCTION

1. Start engine and warm it up to normal operating temperature.
2. Check the voltage between ECM harness connector terminals as per the following.

| Connector | ECM   |          | Voltage (V) |
|-----------|---|----------|-------------|
|           | +   | -        |             |
|           | Terminal  | Terminal |             |
| M160      | 143<br>(EVAP control system pressure sensor signal) | 175      | Approx. 4.0 |

Is the inspection result normal?

- YES >> INSPECTION END  
NO >> Go to [EC-1973, "Diagnosis Procedure"](#).

### Diagnosis Procedure

INFOID:000000007801179

#### 1. CHECK EVAP CONTROL SYSTEM PRESSURE SENSOR CONNECTOR

1. Disconnect EVAP control system pressure sensor harness connector.
2. Check that water is not inside connectors.

Is the inspection result normal?

- YES >> GO TO 2.  
NO >> Repair or replace harness connector.

#### 2. CHECK EVAP CONTROL SYSTEM PRESSURE SENSOR POWER SUPPLY CIRCUIT

1. Turn ignition switch ON.
2. Check the voltage between EVAP control system pressure sensor harness connector and ground.

| EVAP control system pressure sensor |          | Ground | Voltage (V) |
|-------------------------------------|----------|--------|-------------|
| Connector                           | Terminal |        |             |
| B73                                 | 3        | Ground | Approx. 5 V |

Is the inspection result normal?

- YES >> GO TO 7.  
NO >> GO TO 3.

#### 3. CHECK SENSOR POWER SUPPLY CIRCUIT

Check harness for short to power and short to ground, between the following terminals.

| ECM       |          | Sensor                              |           |          |
|-----------|----------|-------------------------------------|-----------|----------|
| Connector | Terminal | Name                                | Connector | Terminal |
| F111      | 76       | CKP sensor                          | F2        | 1        |
|           | 77       | Camshaft position sensor (bank 1)   | F84       | 1        |
| M160      | 133      | Battery current sensor              | E21       | 1        |
|           | 133      | EVAP control system pressure sensor | B73       | 3        |
|           | 133      | Refrigerant pressure sensor         | E77       | 3        |
|           | 131      | APP sensor 2 (Without ICC)          | M9        | 6        |
|           | 131      | APP sensor 2 (With ICC)             | M153      | 3        |

Is the inspection result normal?

# EVAP CONTROL SYSTEM PRESSURE SENSOR

[VK56VD FOR MEXICO]

< DTC/CIRCUIT DIAGNOSIS >

- YES >> GO TO 4.  
NO >> Repair short to ground or short to power in harness or connectors.

## 4.CHECK COMPONENTS

Check the following.

- CKP sensor (Refer to [EC-1826, "Component Inspection \(Crankshaft Position Sensor\)"](#).)
- Camshaft position sensor (bank 1) (Refer to [EC-1831, "Component Inspection \(Camshaft Position Sensor\)"](#).)
- Battery current sensor (Refer to [EC-1906, "Component Inspection \(Battery Current Sensor\)"](#).)
- EVAP control system pressure sensor (Refer to [EC-1974, "Component Inspection \(EVAP Control System Pressure Sensor\)"](#).)
- Refrigerant pressure sensor (Refer to [EC-2001, "Diagnosis Procedure"](#).)

Is the inspection result normal?

- YES >> GO TO 5.  
NO >> Replace malfunctioning component.

## 5.CHECK APP SENSOR

Refer to [EC-1952, "Component Inspection \(Accelerator Pedal Position Sensor\)"](#).

Is the inspection result normal?

- YES >> GO TO 8.  
NO >> GO TO 6.

## 6.REPLACE ACCELERATOR PEDAL ASSEMBLY

Replace accelerator pedal assembly.

Refer to [ACC-3, "MODELS WITHOUT DISTANCE CONTROL ASSIST SYSTEM : Removal and Installation"](#) (Without distance control assist system)

Refer to [ACC-4, "MODELS WITH DISTANCE CONTROL ASSIST SYSTEM : Removal and Installation"](#) (With distance control assist system).

>> INSPECTION END

## 7.CHECK EVAP CONTROL SYSTEM PRESSURE SENSOR

Refer to [EC-1974, "Component Inspection \(EVAP Control System Pressure Sensor\)"](#).

Is the inspection result normal?

- YES >> GO TO 8.  
NO >> Replace EVAP control system pressure sensor. Refer to [FL-13, "Exploded View"](#).

## 8.CHECK INTERMITTENT INCIDENT

Refer to [GI-44, "Intermittent Incident"](#).

>> INSPECTION END

## Component Inspection (EVAP Control System Pressure Sensor)

INFOID:000000007801180

### 1.CHECK EVAP CONTROL SYSTEM PRESSURE SENSOR

1. Turn ignition switch OFF.
2. Remove EVAP control system pressure sensor with its harness connector. Refer to [FL-13, "Exploded View"](#).

**Always replace O-ring with a new one.**

3. Install a vacuum pump to EVAP control system pressure sensor.
4. Turn ignition switch ON and check output voltage between ECM harness connector terminals under the following conditions.

# EVAP CONTROL SYSTEM PRESSURE SENSOR

< DTC/CIRCUIT DIAGNOSIS >

[VK56VD FOR MEXICO]

| ECM       |               |               | Condition<br>[Applied vacuum kPa (kg/cm <sup>2</sup> , psi)] | Voltage (V)                       |
|-----------|---------------|---------------|--|-----------------------------------|
| Connector | +<br>Terminal | -<br>Terminal |  |                                   |
| M160      | 143           | 175           | Not applied  | 1.8 - 4.8                         |
|           |               |               | -26.7 (-0.272, -3.87)  | 2.1 to 2.5 lower than above value |

**CAUTION:**

- Always calibrate the vacuum pump gauge when using it.
- Never apply below -93.3 kPa (-0.952 kg/cm<sup>2</sup>, -13.53 psi) or pressure over 101.3 kPa (1.033 kg/cm<sup>2</sup>, 14.69 psi).

Is the inspection result normal?

YES >> INSPECTION END

NO >> Replace EVAP control system pressure sensor. Refer to [FL-13. "Exploded View"](#).

A  
EC  
C  
D  
E  
F  
G  
H  
I  
J  
K  
L  
M  
N  
O  
P

## FUEL INJECTOR

### Component Function Check

INFOID:000000007758545

#### 1.INSPECTION START

Turn ignition switch to START.

Are any cylinders ignited?

- YES >> GO TO 2.
- NO >> Proceed to [EC-1976, "Diagnosis Procedure"](#).

#### 2.CHECK FUEL INJECTOR FUNCTION

##### Ⓜ WITH CONSULT

1. Start engine.
2. Perform "POWER BALANCE" in "ACTIVE TEST" mode with CONSULT.
3. Check that each circuit produces a momentary engine speed drop.

##### ⓧ WITHOUT CONSULT

1. Start engine.
2. Listen to each fuel injector operating sound.

**Clicking sound should be heard.**

Is the inspection result normal?

- YES >> INSPECTION END
- NO >> Proceed to [EC-1976, "Diagnosis Procedure"](#).

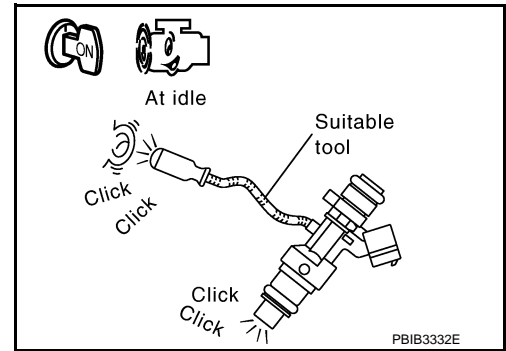

### Diagnosis Procedure

INFOID:000000007758546

#### 1.CHECK FUEL INJECTOR POWER SUPPLY

1. Turn ignition switch ON.
2. Check the voltage between ECM harness connector and ground.

| +         |          | -      | Voltage         |  |  |
|-----------|----------|--------|-----------------|--|--|
| ECM       |          |        |                 |  |  |
| Connector | Terminal | Ground | Battery voltage |  |  |
| F110      | 46       |        |                 |  |  |
|           | 51       |        |                 |  |  |
| M160      | 111      |        |                 |  |  |
|           | 112      |        |                 |  |  |

Is the inspection result normal?

- YES >> GO TO 2.
- NO >> Perform the trouble diagnosis for power supply circuit.

#### 2.CHECK FUEL INJECTOR CIRCUIT

1. Turn ignition switch OFF.
2. Disconnect fuel injector harness connector and ECM harness connector.
3. Check the continuity between fuel injector harness connector and ECM harness connector.



# FUEL INJECTOR

< DTC/CIRCUIT DIAGNOSIS >

[VK56VD FOR MEXICO]

| Cylinder | +             |          | -         |          | Continuity |
|----------|---------------|----------|-----------|----------|------------|
|          | Fuel injector |          | ECM       |          |            |
|          | Connector     | Terminal | Connector | Terminal |            |
| 1        | F131          | 1        | F111      | 101      | Existed    |
|          |               | 2        |           | 108      |            |
| 2        | F132          | 1        | F110      | 7        |            |
|          |               | 2        |           | 4        |            |
| 3        | F133          | 1        | F110      | 6        |            |
|          |               | 2        |           | 3        |            |
| 4        | F134          | 1        | F111      | 107      |            |
|          |               | 2        |           | 104      |            |
| 5        | F135          | 1        | F110      | 2        |            |
|          |               | 2        |           | 9        |            |
| 6        | F136          | 1        | F111      | 102      |            |
|          |               | 2        |           | 109      |            |
| 7        | F137          | 1        | F111      | 106      |            |
|          |               | 2        |           | 103      |            |
| 8        | F138          | 1        | F110      | 1        |            |
|          |               | 2        |           | 8        |            |

4. Also check harness for short to ground and to power.

Is the inspection result normal?

YES >> GO TO 3.

NO >> Repair or replace error-detected parts.

## 3. CHECK ECM GROUND CIRCUIT

Check the continuity between ECM harness connector and ground.

| +         |          | -      | Continuity |
|-----------|----------|--------|------------|
| ECM       |          |        |            |
| Connector | Terminal |        |            |
| F110      | 5        | Ground | Existed    |
| M160      | 114      |        |            |
|           | 115      |        |            |

Is inspection result normal?

YES >> GO TO 4.

NO >> Repair or replace error-detected parts.

## 4. CHECK FUEL INJECTOR

Refer to [EC-1977. "Component Inspection"](#).

Is the inspection result normal?

YES >> Check intermittent incident. Refer to [GI-44. "Intermittent Incident"](#).

NO >> Replace malfunctioning fuel injector.

## Component Inspection

INFOID:000000007758547

### 1. CHECK FUEL INJECTOR

1. Turn ignition switch OFF.
2. Disconnect fuel injector harness connector.
3. Check the resistance between fuel injector terminals as per the following.

# FUEL INJECTOR

< DTC/CIRCUIT DIAGNOSIS >

[VK56VD FOR MEXICO]

| +        |   | -           |                        | Condition     | Resistance |
|----------|---|-------------|------------------------|---------------|------------|
| Injector |   |             |                        |               |            |
| Terminal |   |             |                        |               |            |
| 1        | 2 | Temperature | 10 - 60°C (50 - 140°F) | 1.44 - 1.73 Ω |            |

Is the inspection result normal?

YES >> INSPECTION END

NO >> Replace malfunctioning fuel injector.

# HIGH PRESSURE FUEL PUMP

< DTC/CIRCUIT DIAGNOSIS >

[VK56VD FOR MEXICO]

## HIGH PRESSURE FUEL PUMP

### Component Function Check

INFOID:000000007758548

#### 1. CHECK HIGH PRESSURE FUEL PUMP FUNCTION

##### ④ WITH CONSULT

1. Start engine.
2. Check "FUEL PRES SEN V" in "DATA MONITOR" mode with CONSULT.

| Monitor Item    | Condition   | Values/Status  |
|-----------------|---|----------------|
| FUEL PRES SEN V | Engine speed: Idle  | 820 – 1,220 mV |
|                 | Engine speed: Revving engine from idle to 4,000 rpm quickly | 820 – 3,060 mV |

##### ⊗ WITHOUT CONSULT

1. Start engine.
2. Check the voltage between ECM harness connector and ground.

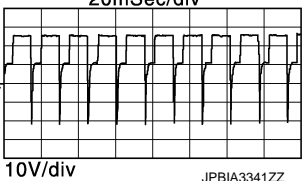
| ECM       |          |           |          | Condition  | Voltage  |
|-----------|----------|-----------|----------|--|--|
| +         |          | -         |          |  |  |
| Connector | Terminal | Connector | Terminal |  |  |
| F111      | 105      | M160      | 175      | [Engine is running] <ul style="list-style-type: none"> <li>• Warm-up condition</li> <li>• Idle speed</li> </ul> <b>NOTE:</b><br>The pulse cycle changes depending on rpm at idle | BATTERY VOLTAGE<br>(11 - 14 V)★<br>20mSec/div<br>  |
|           |          |           |          | [Engine is running] <ul style="list-style-type: none"> <li>• Warm-up condition</li> <li>• Engine speed: 2,000 rpm</li> </ul>   | BATTERY VOLTAGE<br>(11 - 14 V)★<br>20mSec/div<br> |

Is the inspection result normal?

- YES >> INSPECTION END  
 NO >> Proceed to [EC-1979, "Diagnosis Procedure"](#).

### Diagnosis Procedure

INFOID:000000007758549

#### 1. CHECK HIGH PRESSURE FUEL PUMP CIRCUIT

1. Turn ignition switch OFF.
2. Disconnect ECM harness connector and high pressure fuel pump harness connector.
3. Check the continuity between ECM harness connector and high pressure fuel pump harness connector.

| +         |          | -                       |          | Continuity |
|-----------|----------|-------------------------|----------|------------|
| ECM       |          | High pressure fuel pump |          |            |
| Connector | Terminal | Connector               | Terminal |            |
| F111      | 110      | F4                      | 2        | Existed    |
|           | 105      |                         | 1        | Existed    |

# HIGH PRESSURE FUEL PUMP

[VK56VD FOR MEXICO]

## < DTC/CIRCUIT DIAGNOSIS >

4. Also check harness for short to ground and to power.

Is inspection result normal?

YES >> GO TO 2.

NO >> Repair or replace error-detected parts.

## 2.CHECK HIGH PRESSURE FUEL PUMP

Refer to [EC-1980, "Component Inspection"](#).

Is inspection result normal?

YES >> GO TO 3.

NO >> Replace high pressure fuel pump. Refer to [EM-193, "Removal and Installation"](#).

## 3.CHECK HIGH PRESSURE FUEL PUMP INSTALLATION CONDITION

1. Turn ignition switch OFF.

2. Check that the high pressure fuel pump is installed with no backlash and looseness.

Is the inspection result normal?

YES >> GO TO 4.

NO >> Repair or replace error-detected parts.

## 4.CHECK CAMSHAFT

1. Remove camshaft. Refer to [EM-247, "Disassembly and Assembly"](#).

2. Check camshaft. Refer to [EM-255, "Inspection"](#).

Is inspection result normal?

YES >> INSPECTION END

NO >> Replace camshaft.

## Component Inspection

INFOID:000000007758550

## 1.CHECK HIGH PRESSURE FUEL PUMP SOLENOID

1. Turn ignition switch OFF.

2. Disconnect high pressure fuel pump harness connector.

3. Check the resistance between high pressure fuel pump connector terminals as per the following.

| +                       |   | -           |                       | Condition | Resistance |
|-------------------------|---|-------------|-----------------------|-----------|------------|
| High pressure fuel pump |   |             |                       |           |            |
| Terminal                |   |             |                       |           |            |
| 1                       | 2 | Temperature | 20 – 30°C (68 – 86°F) | 9 – 11 Ω  |            |

Is the inspection result normal?

YES >> INSPECTION END

NO >> Replace high pressure fuel pump.

## ICC BRAKE SWITCH

### Component Function Check

INFOID:000000007758551

#### 1. CHECK ICC BRAKE SWITCH FUNCTION

##### WITH CONSULT

1. Turn ignition switch ON.
2. Select "BRAKE SW1" in "DATA MONITOR" mode with CONSULT.
3. Check "BRAKE SW1" indication under the following conditions.

| Monitor item                    | Condition   | Indication         |     |
|---------------------------------|-------------|--------------------|-----|
| BRAKE SW1<br>(ICC brake switch) | Brake pedal | Slightly depressed | OFF |
|                                 |             | Fully released     | ON  |

##### WITHOUT CONSULT

1. Turn ignition switch ON.
2. Check the voltage between ECM harness connector terminals as per the following.

| ECM       |                                  |          | Condition      | Voltage            |             |
|-----------|----------------------------------|----------|----------------|--------------------|-------------|
| Connector | +                                | -        |                |                    |             |
|           |                                  | Terminal | Terminal       |                    |             |
| M160      | 147<br>(ICC brake switch signal) | 175      | Brake pedal    | Slightly depressed | Approx. 0 V |
|           |                                  |          | Fully released | Battery voltage    |             |

Is the inspection result normal?

- YES >> INSPECTION END  
 NO >> Proceed to [EC-1981, "Diagnosis Procedure"](#).

### Diagnosis Procedure

INFOID:000000007758552

#### 1. CHECK ICC BRAKE SWITCH POWER SUPPLY CIRCUIT

1. Turn ignition switch OFF.
2. Disconnect ICC brake switch harness connector.
3. Turn ignition switch ON.
4. Check the voltage between ICC brake switch harness connector and ground.

| ICC brake switch |          | Ground | Voltage         |
|------------------|----------|--------|-----------------|
| Connector        | Terminal |        |                 |
| E114             | 1        | Ground | Battery voltage |

Is the inspection result normal?

- YES >> GO TO 3.  
 NO >> GO TO 2.

#### 2. DETECT MALFUNCTIONING PART

Check the following.

- 10 A fuse (No. 3)
- Harness for open or short between ICC brake switch and fuse
- Loose or poor connection for each connector and harness

>> Repair open circuit or short to ground in harness or connectors.

#### 3. CHECK ICC BRAKE SWITCH INPUT SIGNAL CIRCUIT FOR OPEN AND SHORT

1. Turn ignition switch OFF.
2. Disconnect ECM harness connector.

# ICC BRAKE SWITCH

[VK56VD FOR MEXICO]

## < DTC/CIRCUIT DIAGNOSIS >

3. Check the continuity between ICC brake switch harness connector and ECM harness connector.

| ICC brake switch |          | ECM       |          | Continuity |
|------------------|----------|-----------|----------|------------|
| Connector        | Terminal | Connector | Terminal |            |
| E114             | 2        | M160      | 147      | Existed    |

4. Also check harness for short to ground and short to power.

Is the inspection result normal?

YES >> GO TO 5.

NO >> GO TO 4.

## 4. DETECT MALFUNCTIONING PART

Check the following.

- Harness for open or short between ECM and ICC brake switch
- Loose or poor connection for each connector and harness

>> Repair open circuit, short to ground or short to power in harness or connectors.

## 5. CHECK ICC BRAKE SWITCH

Refer to [EC-1934, "Component Inspection \(ICC Brake Switch\)"](#).

Is the inspection result normal?

YES >> GO TO 6.

NO >> Replace ICC brake switch.

## 6. CHECK INTERMITTENT INCIDENT

Refer to [GI-44, "Intermittent Incident"](#).

>> INSPECTION END

## Component Inspection (ICC Brake Switch)

INFOID:000000007758553

### 1. CHECK ICC BRAKE SWITCH-I

1. Turn ignition switch OFF.
2. Disconnect ICC brake switch harness connector.
3. Check the continuity between ICC brake switch terminals under the following conditions.

| Terminals | Condition   |                    | Continuity  |
|-----------|-------------|--------------------|-------------|
| 1 and 2   | Brake pedal | Fully released     | Existed     |
|           |             | Slightly depressed | Not existed |

Is the inspection result normal?

YES >> INSPECTION END

NO >> GO TO 2.

### 2. CHECK ICC BRAKE SWITCH-II

1. Adjust ICC brake switch installation. Refer to [BR-7, "Inspection and Adjustment"](#).
2. Check the continuity between ICC brake switch terminals under the following conditions.

| Terminals | Condition   |                    | Continuity  |
|-----------|-------------|--------------------|-------------|
| 1 and 2   | Brake pedal | Fully released     | Existed     |
|           |             | Slightly depressed | Not existed |

Is the inspection result normal?

YES >> INSPECTION END

NO >> Replace ICC brake switch.

# ICC BRAKE SWITCH

< DTC/CIRCUIT DIAGNOSIS >

[VK56VD FOR MEXICO]

## Component Inspection (ICC Brake Hold Relay)

INFOID:000000007758554

### 1. CHECK ICC BRAKE HOLD RELAY

1. Turn ignition switch OFF.
2. Remove ICC brake hold relay.
3. Check the continuity between ICC brake hold relay terminals under the following conditions.

| Terminals | Condition   | Continuity  |
|-----------|---|-------------|
| 3 and 5   | 12V direct current supply between terminals 1 and 2 | Existed     |
|           | No current supply                                   | Not existed |

Is the inspection result normal?

- YES >> INSPECTION END  
NO >> Replace ICC brake hold relay

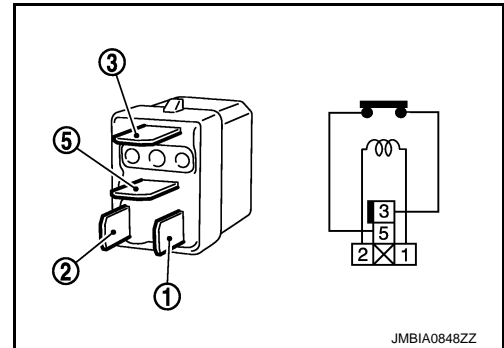

A

EC

C

D

E

F

G

H

I

J

K

L

M

N

O

P

## IGNITION SIGNAL

### Component Function Check

INFOID:000000007758555

#### 1.INSPECTION START

Turn ignition switch OFF, and restart engine.

Does the engine start?

- YES-1 >> With CONSULT: GO TO 2.
- YES-2 >> Without CONSULT: GO TO 3.
- NO >> Proceed to [EC-1984, "Diagnosis Procedure"](#).

#### 2.CHECK IGNITION SIGNAL FUNCTION

WITH CONSULT

1. Perform "POWER BALANCE" in "ACTIVE TEST" mode with CONSULT.
2. Check that each circuit produces a momentary engine speed drop.

Is the inspection result normal?

- YES >> INSPECTION END
- NO >> Proceed to [EC-1984, "Diagnosis Procedure"](#).

#### 3.CHECK IGNITION SIGNAL FUNCTION

WITHOUT CONSULT

1. Let engine idle.
2. Read the voltage signal between ECM harness connector terminals under the following conditions with an oscilloscope.

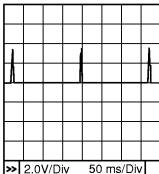
| Cylinder | ECM       |          |           |          | Voltage signal   |
|----------|-----------|----------|-----------|----------|--|
|          | +         |          | -         |          |  |
|          | Connector | Terminal | Connector | Terminal |  |
| 1        | F110      | 12       | M160      | 175      |  |
| 2        |           | 13       |           |          |  |
| 3        |           | 14       |           |          |  |
| 4        |           | 15       |           |          |  |
| 5        |           | 17       |           |          |  |
| 6        |           | 18       |           |          |  |
| 7        |           | 19       |           |          |  |
| 8        |           | 20       |           |          |  |

**NOTE:**

The pulse cycle changes depending on rpm at idle.

Is the inspection result normal?

- YES >> INSPECTION END
- NO >> Proceed to [EC-1984, "Diagnosis Procedure"](#).

### Diagnosis Procedure

INFOID:000000007758556

#### 1.CHECK IGNITION COIL POWER SUPPLY CIRCUIT-I

1. Turn ignition switch OFF, wait at least 10 seconds and then turn it ON.
2. Check the voltage between ECM harness connector terminals under the following conditions.



# IGNITION SIGNAL

< DTC/CIRCUIT DIAGNOSIS >

[VK56VD FOR MEXICO]

| ECM       |          |          | Voltage         |
|-----------|----------|----------|-----------------|
| Connector | +        | -        |                 |
|           | Terminal | Terminal |                 |
| M160      | 171      | 175      | Battery voltage |
|           | 172      |          |                 |

Is the inspection result normal?

YES >> GO TO 2.

NO >> Proceed to [EC-1707, "Diagnosis Procedure"](#).

## 2.CHECK IGNITION COIL POWER SUPPLY CIRCUIT-II

1. Turn ignition switch OFF.
2. Disconnect condenser harness connector.
3. Turn ignition switch ON.
4. Check the voltage between condenser harness connector and ground.

| Condenser |          | Ground | Voltage         |
|-----------|----------|--------|-----------------|
| Connector | Terminal |        |                 |
| F41       | 1        | Ground | Battery voltage |

Is the inspection result normal?

YES >> GO TO 5.

NO >> GO TO 3.

## 3.CHECK IGNITION COIL POWER SUPPLY CIRCUIT-III

1. Turn ignition switch OFF.
2. Disconnect IPDM E/R harness connector E7.
3. Check the continuity between IPDM E/R harness connector and condenser harness connector.

| IPDM E/R  |          | Condenser |          | Continuity |
|-----------|----------|-----------|----------|------------|
| Connector | Terminal | Connector | Terminal |            |
| E5        | 5        | F41       | 1        | Existed    |

4. Also check harness for short to ground and short to power.

Is the inspection result normal?

YES >> Proceed to [EC-1707, "Diagnosis Procedure"](#).

NO >> GO TO 4.

## 4.DETECT MALFUNCTIONING PART

Check the following.

- Harness for open or short between IPDM E/R and condenser
- Loose or poor connection for each connector and harness

>> Repair open circuit, short to ground or short to power in harness or connectors.

## 5.CHECK CONDENSER GROUND CIRCUIT FOR OPEN AND SHORT

1. Turn ignition switch OFF.
2. Check the continuity between condenser harness connector and ground.

| Condenser |          | Ground | Continuity |
|-----------|----------|--------|------------|
| Connector | Terminal |        |            |
| F41       | 2        | Ground | Existed    |

3. Also check harness for short to power.

Is the inspection result normal?

# IGNITION SIGNAL

[VK56VD FOR MEXICO]

## < DTC/CIRCUIT DIAGNOSIS >

- YES >> GO TO 6.  
NO >> Repair open circuit or short to power in harness or connectors.

### 6. CHECK CONDENSER

Refer to [EC-1988. "Component Inspection \(Condenser\)"](#)

Is the inspection result normal?

- YES >> GO TO 7.  
NO >> Replace condenser.

### 7. CHECK IGNITION COIL POWER SUPPLY CIRCUIT-IV

1. Reconnect all harness connectors disconnected.
2. Disconnect ignition coil harness connector.
3. Turn ignition switch ON.
4. Check the voltage between ignition coil harness connector and ground.

| Ignition coil |           |          | Ground | Voltage         |
|---------------|-----------|----------|--------|-----------------|
| Cylinder      | Connector | Terminal |        |                 |
| 1             | F91       | 3        | Ground | Battery voltage |
| 2             | F92       | 3        |        |                 |
| 3             | F93       | 3        |        |                 |
| 4             | F94       | 3        |        |                 |
| 5             | F95       | 3        |        |                 |
| 6             | F96       | 3        |        |                 |
| 7             | F97       | 3        |        |                 |
| 8             | F98       | 3        |        |                 |

Is the inspection result normal?

- YES >> GO TO 9.  
NO >> GO TO 8.

### 8. DETECT MALFUNCTIONING PART

Check the following.

- Harness connector F40 or E20
- Harness for open or short between ignition coil and harness connector F40

>> Repair or replace harness or connectors.

### 9. CHECK IGNITION COIL GROUND CIRCUIT FOR OPEN AND SHORT

1. Turn ignition switch OFF.
2. Check the continuity between ignition coil harness connector and ground.

| Ignition coil |           |          | Ground | Continuity |
|---------------|-----------|----------|--------|------------|
| Cylinder      | Connector | Terminal |        |            |
| 1             | F91       | 2        | Ground | Existed    |
| 2             | F92       | 2        |        |            |
| 3             | F93       | 2        |        |            |
| 4             | F94       | 2        |        |            |
| 5             | F95       | 2        |        |            |
| 6             | F96       | 2        |        |            |
| 7             | F97       | 2        |        |            |
| 8             | F98       | 2        |        |            |

3. Also check harness for short to power.

Is the inspection result normal?

# IGNITION SIGNAL

[VK56VD FOR MEXICO]

## < DTC/CIRCUIT DIAGNOSIS >

- YES >> GO TO 10.  
NO >> Repair open circuit or short to power in harness or connectors.

### 10.CHECK IGNITION COIL OUTPUT SIGNAL CIRCUIT FOR OPEN AND SHORT

1. Disconnect ECM harness connector.
2. Check the continuity between ignition coil harness connector and ECM harness connector.

| Ignition coil |           |          | ECM       |          | Continuity |
|---------------|-----------|----------|-----------|----------|------------|
| Cylinder      | Connector | Terminal | Connector | Terminal |            |
| 1             | F91       | 1        | F110      | 12       | Existed    |
| 2             | F92       | 1        |           | 13       |            |
| 3             | F93       | 1        |           | 14       |            |
| 4             | F94       | 1        |           | 15       |            |
| 5             | F95       | 1        |           | 17       |            |
| 6             | F96       | 1        |           | 18       |            |
| 7             | F97       | 1        |           | 19       |            |
| 8             | F98       | 1        |           | 20       |            |

3. Also check harness for short to ground and short to power.

Is the inspection result normal?

- YES >> GO TO 11.  
NO >> Repair open circuit, short to ground or short to power in harness or connectors.

### 11.CHECK IGNITION COIL WITH POWER TRANSISTOR

Refer to [EC-1987. "Component Inspection \(Ignition Coil with Power Transistor\)".](#)

Is the inspection result normal?

- YES >> GO TO 12.  
NO >> Replace malfunctioning ignition coil with power transistor. Refer to [EM-186. "Removal and Installation".](#)

### 12.CHECK INTERMITTENT INCIDENT

Refer to [GI-44. "Intermittent Incident".](#)

>> INSPECTION END

## Component Inspection (Ignition Coil with Power Transistor)

INFOID:000000007758557

### 1.CHECK IGNITION COIL WITH POWER TRANSISTOR-I

1. Turn ignition switch OFF.
2. Disconnect ignition coil harness connector.
3. Check resistance between ignition coil terminals as per the following.

| Terminals | Resistance [at 25°C (77°F)]   |
|-----------|-------------------------------|
| 1 and 2   | Except 0 or $\infty$ $\Omega$ |
| 1 and 3   | Except 0 $\Omega$             |
| 2 and 3   |                               |

Is the inspection result normal?

- YES >> GO TO 2.  
NO >> Replace malfunctioning ignition coil with power transistor.

### 2.CHECK IGNITION COIL WITH POWER TRANSISTOR-II

#### **CAUTION:**

**Perform the following procedure in a place with no combustible objects and good ventilation.**

1. Turn ignition switch OFF.

# IGNITION SIGNAL

[VK56VD FOR MEXICO]

## < DTC/CIRCUIT DIAGNOSIS >

2. Reconnect all harness connectors disconnected.
3. Remove fuel pump fuse in IPDM E/R to release fuel pressure.  
**NOTE:**
  - For the fuse number, refer to [EC-1667, "Wiring Diagram"](#).
  - For the fuse arrangement, refer to [PG-40, "Fuse, Connector and Terminal Arrangement"](#).
  - Do not use CONSULT to release fuel pressure, or fuel pressure applies again during the following procedure.
4. Start engine.
5. After engine stalls, crank it 2 or 3 times to release all fuel pressure.
6. Turn ignition switch OFF.
7. Remove all ignition coil harness connectors to avoid the electrical discharge from the ignition coils.
8. Remove ignition coil and spark plug of the cylinder to be checked.
9. Crank engine for 5 seconds or more to remove combustion gas in the cylinder.
10. Connect spark plug and harness connector to ignition coil.
11. Fix ignition coil using a rope etc. with gap of 13 - 17 mm (0.52 - 0.66 in) between the edge of the spark plug and grounded metal portion as shown in the figure.
12. Crank engine for approximately 3 seconds, and check whether spark is generated between the spark plug and the grounded metal portion.

**Spark should be generated.**

### **CAUTION:**

- **Never place the spark plug and the ignition coil within 50 cm (19.7 in) each other. Be careful not to get an electrical shock while checking, because the electrical discharge voltage becomes 20 kV or more.**
- **It might damage the ignition coil if the gap of more than 17 mm (0.66 in) is made.**

### **NOTE:**

**When the gap is less than 13 mm (0.52 in), a spark might be generated even if the coil is malfunctioning.**

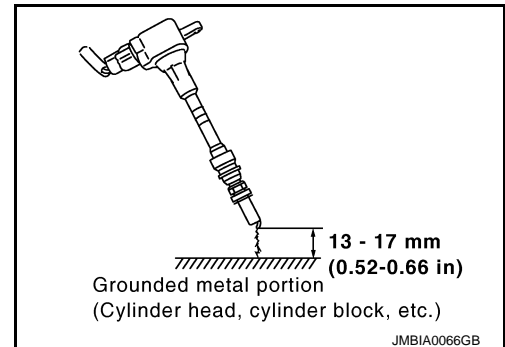

Is the inspection result normal?

YES >> INSPECTION END

NO >> Replace malfunctioning ignition coil with power transistor.

## Component Inspection (Condenser)

INFOID:000000007758558

### 1. CHECK CONDENSER

1. Turn ignition switch OFF.
2. Disconnect condenser harness connector.
3. Check resistance between condenser terminals as per the following.

| Terminals | Resistance                  |
|-----------|-----------------------------|
| 1 and 2   | Above 1 MΩ [at 25°C (77°F)] |

Is the inspection result normal?

YES >> INSPECTION END

NO >> Replace condenser.

# LOW PRESSURE FUEL PUMP

< DTC/CIRCUIT DIAGNOSIS >

[VK56VD FOR MEXICO]

## LOW PRESSURE FUEL PUMP

### Component Function Check

INFOID:000000007758561

#### 1.CHECK FUEL PUMP FUNCTION

1. Turn ignition switch ON.
2. Pinch fuel feed hose with two fingers.

**NOTE:**

Fuel pressure pulsation should be felt on the fuel feed hose for 1 second after ignition switch is turned ON.

Is the inspection result normal?

- YES >> INSPECTION END  
 NO >> [EC-1989, "Diagnosis Procedure"](#).

### Diagnosis Procedure

INFOID:000000007758562

#### 1.CHECK FPCM POWER SUPPLY CIRCUIT

1. Turn ignition switch OFF.
2. Disconnect FPCM harness connector.
3. Turn ignition switch ON.
4. Check the voltage between FPCM harness connector and ground.

| +         |          | -      | Voltage         |
|-----------|----------|--------|-----------------|
| FPCM      |          |        |                 |
| Connector | Terminal |        |                 |
| B221      | 10       | Ground | Battery voltage |

Is the inspection result normal?

- YES >> GO TO 2.  
 NO >> Perform the trouble diagnosis for power supply circuit. Refer to [EC-1707, "Diagnosis Procedure"](#).

#### 2.CHECK FPCM GROUND CIRCUIT

1. Turn ignition switch OFF.
2. Check the continuity between FPCM harness connector and ground.

| +         |          | -      | Continuity |
|-----------|----------|--------|------------|
| FPCM      |          |        |            |
| Connector | Terminal |        |            |
| B221      | 5        | Ground | Existed    |

Is the inspection result normal?

- YES >> GO TO 3.  
 NO >> Repair open circuit or short to power in harness or connectors.

#### 3.CHECK FPCM INPUT AND OUTPUT CIRCUIT

1. Disconnect ECM harness connector.
2. Check the continuity between FPCM harness connector and ECM harness connector.

| +         |          | -         |          | Continuity |
|-----------|----------|-----------|----------|------------|
| FPCM      |          | ECM       |          |            |
| Connector | Terminal | Connector | Terminal |            |
| B221      | 8        | M160      | 125      | Existed    |
|           | 9        |           | 142      |            |

3. Also check harness for short to ground and to power.

Is the inspection result normal?

# LOW PRESSURE FUEL PUMP

[VK56VD FOR MEXICO]

## < DTC/CIRCUIT DIAGNOSIS >

- YES >> GO TO 4.  
NO >> Repair or replace error-detected parts.

### 4.CHECK FUEL PUMP CONTROL CIRCUIT

1. Disconnect fuel level sensor unit and fuel pump (main) harness connector.
2. Check the continuity between FPCM harness connector and fuel level sensor unit and fuel pump (main) harness connector.

| +         |          | -   |          | Continuity |
|-----------|----------|---|----------|------------|
| FPCM      |          | Fuel level sensor unit and fuel pump (main) |          |            |
| Connector | Terminal | Connector                                   | Terminal |            |
| B221      | 6        | B241  | 3        | Existed    |
|           | 7        |   | 1        |            |

3. Also check harness for short to ground and to power.

#### Is the inspection result normal?

- YES >> GO TO 5.  
NO >> Repair or replace error-detected parts.

### 5.CHECK LOW PRESSURE FUEL PUMP

Refer to [EC-1990, "Component Inspection \(Low Pressure Fuel Pump\)"](#).

#### Is the inspection result normal?

- YES >> GO TO 6.  
NO >> Replace low pressure fuel pump. Refer to [FL-6, "Removal and Installation"](#).

### 6.CHECK FPCM

Refer to [EC-1991, "Component Inspection \(FPCM\)"](#).

#### Is the inspection result normal?

- YES >> Check intermittent incident. Refer to [GI-44, "Intermittent Incident"](#).  
NO >> Replace FPCM. Refer to [EC-2015, "Removal and Installation"](#).

## Component Inspection (Low Pressure Fuel Pump)

INFOID:000000007758563

### 1.CHECK FUEL PRESSURE REGULATOR

1. Turn ignition switch OFF.
2. Check low fuel pressure. Refer to [EC-1692, "Work Procedure"](#).

#### Is inspection result normal?

- YES >> INSPECTION END  
NO >> GO TO 2.

### 2.CHECK LOW PRESSURE FUEL PUMP

1. Turn ignition switch OFF.
2. Disconnect fuel level sensor unit and fuel pump (main).
3. Check resistance between fuel level sensor unit and fuel pump (main) terminals as follows.

| +   | - | Condition                | Resistance  |
|---|---|--------------------------|-------------|
| Fuel level sensor unit and fuel pump (main) |   |                          |             |
| Terminals                                   |   |                          |             |
| 1   | 3 | Temperature: 25°C (77°F) | 0.2 - 5.0 Ω |

#### Is the inspection result normal?

- YES >> INSPECTION END  
NO >> Replace fuel level sensor unit and fuel pump (main).

# LOW PRESSURE FUEL PUMP

< DTC/CIRCUIT DIAGNOSIS >

[VK56VD FOR MEXICO]

## Component Inspection (FPCM)

INFOID:000000007758564

### 1. CHECK FUEL PUMP CONTROL MODULE (FPCM)

1. Check the voltage between FPCM terminals under the following conditions.

| FPCM      |          |          | Condition   | Voltage      |
|-----------|----------|----------|---|--------------|
| Connector | +        | -        |   |              |
|           | Terminal | Terminal |   |              |
| B221      | 7        | 6        | For 1 second after turning ignition switch ON       | Approx. 10 V |
|           |          |          | More than 1 second after turning ignition switch ON | Approx. 0 V  |
|           |          |          | Idle speed  | Approx. 10 V |

Is the inspection result normal?

YES >> INSPECTION END

NO >> Replace FPCM.

A

EC

C

D

E

F

G

H

I

J

K

L

M

N

O

P

# MALFUNCTION INDICATOR LAMP

< DTC/CIRCUIT DIAGNOSIS >

[VK56VD FOR MEXICO]

## MALFUNCTION INDICATOR LAMP

### Component Function Check

INFOID:000000007758565

#### 1.CHECK MIL FUNCTION

---

1. Turn ignition switch ON.
2. Check that MIL illuminates.

Is the inspection result normal?

- YES >> INSPECTION END  
NO >> Proceed to [EC-1992. "Diagnosis Procedure"](#).

#### Diagnosis Procedure

INFOID:000000007758566

#### 1.CHECK DTC

---

Check that DTC UXXXX is not displayed.

Is the inspection result normal?

- YES >> GO TO 2.  
NO >> Perform trouble diagnosis for DTC UXXXX.

#### 2.CHECK DTC WITH COMBINATION METER

---

Refer to [MWI-31. "CONSULT Function"](#).

Is the inspection result normal?

- YES >> GO TO 3.  
NO >> Perform trouble diagnosis for DTC indicated.

#### 3.CHECK INTERMITTENT INCIDENT

---

Refer to [GI-44. "Intermittent Incident"](#).

Is the inspection result normal?

- YES >> Replace combination meter. Refer to [MWI-79. "Removal and Installation"](#).  
NO >> Repair or replace malfunctioning part.



# MAP (MANIFOLD ABSOLUTE PRESSURE) SENSOR

< DTC/CIRCUIT DIAGNOSIS >

[VK56VD FOR MEXICO]

## MAP (MANIFOLD ABSOLUTE PRESSURE) SENSOR

### Component Function Check

INFOID:000000007793846

#### 1. CHECK MAP SENSOR FUNCTION

1. Start engine and warm it up to normal operating temperature.
2. Turn ignition switch OFF, wait at least 5 seconds and then turn ON.
3. Check the voltage between ECM harness connector terminals as follows.

| ECM       |          |    |
|-----------|----------|----|
| Connector | +        | -  |
|           | Terminal |    |
| F111      | 67       | 70 |

**NOTE:**

Since this sensor is an absolute pressure sensor and is subject to ambient pressure and altitude, check voltage after a lapse of one minute or more after stopping the engine.

4. Measure the atmospheric pressure.

**NOTE:**

As the atmospheric pressure described on the synoptic chart is the value at sea level, compensate the pressure with the following chart.

| Altitude (m) | Compensated pressure (hPa) |
|--------------|----------------------------|
| 0            | 0                          |
| 200          | -24                        |
| 400          | -47                        |
| 600          | -70                        |
| 800          | -92                        |
| 1000         | -114                       |
| 1500         | -168                       |
| 2000         | -218                       |

5. Check the MAP sensor value corresponding to the atmospheric pressure.

| Atmospheric pressure (hPa) | Voltage (V) |
|----------------------------|-------------|
| 800                        | 3.1 – 3.7   |
| 850                        | 3.3 – 3.9   |
| 900                        | 3.5 – 4.1   |
| 950                        | 3.8 – 4.3   |
| 1000                       | 4.0 – 4.6   |
| 1050                       | 4.2 – 4.8   |

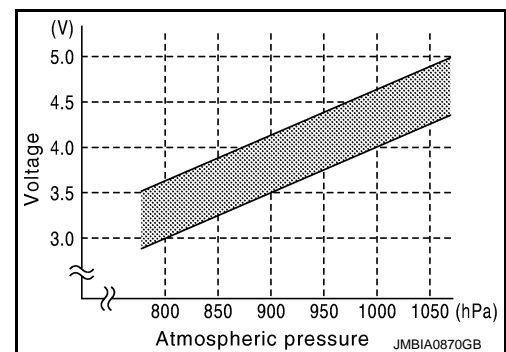

Is the inspection result normal?

YES >> INSPECTION END

NO >> Proceed to [EC-1993, "Diagnosis Procedure"](#).

### Diagnosis Procedure

INFOID:000000007793847

#### 1. CHECK MAP SENSOR POWER SUPPLY CIRCUIT-I

1. Disconnect MAP sensor harness connector.
2. Turn ignition switch ON.
3. Check the voltage between MAP sensor harness connector terminals.

# MAP (MANIFOLD ABSOLUTE PRESSURE) SENSOR

[VK56VD FOR MEXICO]

< DTC/CIRCUIT DIAGNOSIS >

| MAP sensor |          |   | Voltage<br>(Approx.) |
|------------|----------|---|----------------------|
| Connector  | +        | - |                      |
|            | Terminal |   |                      |
| F19        | 1        | 3 | 5 V                  |

Is the inspection result normal?

YES >> GO TO 6.

NO >> GO TO 2.

## 2.CHECK MAP SENSOR POWER SUPPLY CIRCUIT-II

Check the voltage between MAP sensor harness connector and ground.

| +          |          | -      | Voltage<br>(Approx.) |
|------------|----------|--------|----------------------|
| MAP sensor |          |        |                      |
| Connector  | Terminal |        |                      |
| F19        | 1        | Ground | 5 V                  |

Is inspection result normal?

YES >> GO TO 4.

NO >> GO TO 3.

## 3.CHECK MAP SENSOR POWER SUPPLY CIRCUIT-III

1. Turn ignition switch OFF.
2. Disconnect ECM harness connector.
3. Check the continuity between MAP sensor harness connector and ECM harness connector.

| +          |          | -         |          | Continuity |
|------------|----------|-----------|----------|------------|
| MAP sensor |          | ECM       |          |            |
| Connector  | Terminal | Connector | Terminal |            |
| F19        | 1        | F111      | 85       | Existed    |

4. Also check harness for short to ground and to power.

Is the inspection result normal?

YES >> Perform the trouble diagnosis for ignition power supply circuit. Refer to [EC-1707. "Diagnosis Procedure"](#).

NO >> Repair or replace error-detected parts.

## 4.CHECK MAP SENSOR GROUND CIRCUIT

1. Turn ignition switch OFF.
2. Disconnect ECM harness connector.
3. Check the continuity between MAP sensor harness connector and ECM harness connector.

| +          |          | -         |          | Continuity |
|------------|----------|-----------|----------|------------|
| MAP sensor |          | ECM       |          |            |
| Connector  | Terminal | Connector | Terminal |            |
| F19        | 3        | F111      | 70       | Existed    |

Is inspection result normal?

YES >> GO TO 5.

NO >> Repair or replace error-detected parts.

## 5.CHECK ECM GROUND CIRCUIT

Check the continuity between ECM harness connector and the ground.

# MAP (MANIFOLD ABSOLUTE PRESSURE) SENSOR

< DTC/CIRCUIT DIAGNOSIS >

[VK56VD FOR MEXICO]

| +         |          | -      | Continuity |
|-----------|----------|--------|------------|
| ECM       |          |        |            |
| Connector | Terminal | ground | Existed    |
| F110      | 10       |        |            |
| M160      | 174      |        |            |
|           | 175      |        |            |

Is inspection result normal?

YES >> Check intermittent incident. Refer to [GI-44, "Intermittent Incident"](#).

NO >> Repair or replace error-detected parts.

## 6. CHECK MAP SENSOR INPUT SIGNAL CIRCUIT

1. Check the continuity between MAP sensor harness connector and ECM harness connector.

| +          |          | -         |          | Continuity |
|------------|----------|-----------|----------|------------|
| MAP sensor |          | ECM       |          |            |
| Connector  | Terminal | Connector | Terminal | Existed    |
| F19        | 2        | F111      | 67       |            |

2. Also check harness for short to ground and to power.

Is the inspection result normal?

YES >> GO TO 7.

NO >> Repair or replace error-detected parts.

## 7. CHECK MAP SENSOR

Refer to [EC-1995, "Component Inspection"](#).

Is the inspection result normal?

YES >> Check intermittent incident. Refer to [GI-44, "Intermittent Incident"](#).

NO >> Replace MAP sensor. Refer to [EM-190, "Exploded View"](#).

## Component Inspection

INFOID:000000007793848

### 1. CHECK MAP SENSOR

1. Turn ignition switch OFF.
2. Reconnect harness connector disconnected.
3. Start engine and keep the engine speed at idle.
4. Check the voltage between ECM harness connector terminals.

| +         |          | -         |          |
|-----------|----------|-----------|----------|
| ECM       |          |           |          |
| Connector | Terminal | Connector | Terminal |
| F111      | 67       | F111      | 70       |

5. Confirm the difference of the voltage when engine is stopped and at idling is within the values shown in the following chart.

| Intake manifold vacuum [kPa (mmHg)] | Voltage difference (V) |
|-------------------------------------|------------------------|
| -40 (-300)                          | 1.5 – 2.0              |
| -53.3 (-400)                        | 2.0 – 2.6              |
| -66.7 (-500)                        | 2.6 – 3.2              |
| -80 (-600)                          | 3.2 – 3.8              |

Is the inspection result normal?

YES >> INSPECTION END

## MAP (MANIFOLD ABSOLUTE PRESSURE) SENSOR

< DTC/CIRCUIT DIAGNOSIS >

[VK56VD FOR MEXICO]

---

NO >> Replace MAP sensor. Refer to [EM-190. "Exploded View"](#).

# ON BOARD REFUELING VAPOR RECOVERY (ORVR)

< DTC/CIRCUIT DIAGNOSIS >

[VK56VD FOR MEXICO]

## ON BOARD REFUELING VAPOR RECOVERY (ORVR)

### Component Function Check

INFOID:000000007758567

#### 1.CHECK ORVR FUNCTION

Check whether the following symptoms are present.

- Fuel odor from EVAP canister is strong.
- Cannot refuel/Fuel odor from the fuel filler opening is strong while refueling.

Are any symptoms present?

- YES >> Proceed to [EC-1997, "Diagnosis Procedure"](#).  
NO >> INSPECTION END

#### Diagnosis Procedure

INFOID:000000007758568

#### 1.INSPECTION START

Check whether the following symptoms are present.

- A: Fuel odor from EVAP canister is strong.  
B: Cannot refuel/Fuel odor from the fuel filler opening is strong while refueling.

Which symptom is present?

- A >> GO TO 2.  
B >> GO TO 7.

#### 2.CHECK EVAP CANISTER

1. Remove EVAP canister with EVAP canister vent control valve and EVAP control system pressure sensor attached.
2. Weigh the EVAP canister with EVAP canister vent control valve and EVAP control system pressure sensor attached.

**The weight should be less than 2.1 kg (4.6 lb).**

Is the inspection result normal?

- YES >> GO TO 3.  
NO >> GO TO 4.

#### 3.CHECK IF EVAP CANISTER IS SATURATED WITH WATER

Check if water will drain from EVAP canister (1).

- EVAP canister vent control valve (2)

Does water drain from the EVAP canister?

- YES >> GO TO 4.  
NO >> GO TO 6.

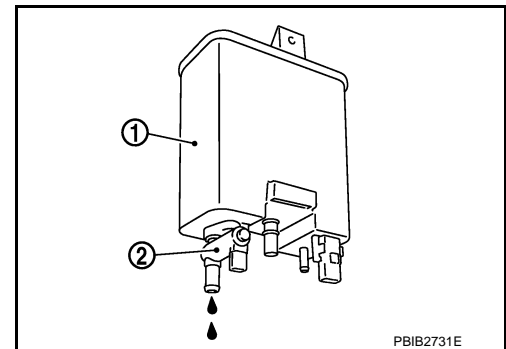

#### 4.REPLACE EVAP CANISTER

Replace EVAP canister with a new one.

>> GO TO 5.

#### 5.DETECT MALFUNCTIONING PART

Check the EVAP hose between EVAP canister and vehicle frame for clogging or poor connection.

>> Repair or replace EVAP hose.

#### 6.CHECK REFUELING EVAP VAPOR CUT VALVE

Refer to [EC-1999, "Component Inspection \(EVAP Vapor Cut Valve\)"](#).

# ON BOARD REFUELING VAPOR RECOVERY (ORVR)

[VK56VD FOR MEXICO]

< DTC/CIRCUIT DIAGNOSIS >

Is the inspection result normal?

YES >> INSPECTION END

NO >> Replace refueling EVAP vapor cut valve with fuel tank.

## 7. CHECK EVAP CANISTER

1. Remove EVAP canister with EVAP canister vent control valve and EVAP control system pressure sensor attached.

2. Weigh the EVAP canister with EVAP canister vent control valve and EVAP control system pressure sensor attached.

**The weight should be less than 2.1 kg (4.6 lb).**

Is the inspection result normal?

YES >> GO TO 8.

NO >> GO TO 9.

## 8. CHECK IF EVAP CANISTER IS SATURATED WITH WATER

Check if water will drain from EVAP canister (1).

• EVAP canister vent control valve (2)

Does water drain from the EVAP canister?

YES >> GO TO 9.

NO >> GO TO 11.

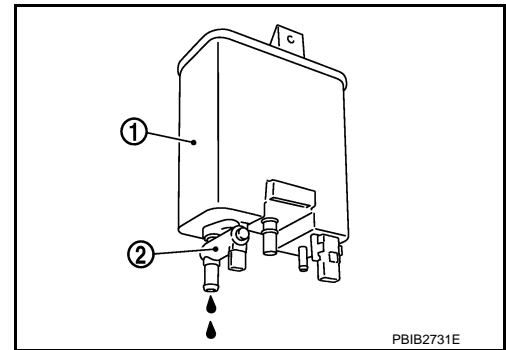

## 9. REPLACE EVAP CANISTER

Replace EVAP canister with a new one.

>> GO TO 10.

## 10. DETECT MALFUNCTIONING PART

Check the EVAP hose between EVAP canister and vehicle frame for clogging or poor connection.

>> Repair or replace EVAP hose.

## 11. CHECK VENT HOSES AND VENT TUBES

Check hoses and tubes between EVAP canister and refueling control valve for clogging, kinks, looseness and improper connection.

Is the inspection result normal?

YES >> GO TO 12.

NO >> Repair or replace hoses and tubes.

## 12. CHECK FILLER NECK TUBE

Check recirculation line for clogging, dents and cracks.

Is the inspection result normal?

YES >> GO TO 13.

NO >> Replace filler neck tube.

## 13. CHECK REFUELING EVAP VAPOR CUT VALVE

Refer to [EC-1999, "Component Inspection \(EVAP Vapor Cut Valve\)"](#).

Is the inspection result normal?

YES >> GO TO 14.

NO >> Replace refueling EVAP vapor cut valve with fuel tank.

## 14. CHECK FUEL FILLER TUBE

Check filler neck tube and hose connected to the fuel tank for clogging, dents and cracks.

# ON BOARD REFUELING VAPOR RECOVERY (ORVR)

[VK56VD FOR MEXICO]

< DTC/CIRCUIT DIAGNOSIS >

Is the inspection result normal?

- YES >> GO TO 15.
- NO >> Replace fuel filler tube.

## 15.CHECK ONE-WAY FUEL VALVE-I

Check one-way fuel valve for clogging.

Is the inspection result normal?

- YES >> GO TO 16.
- NO >> Repair or replace one-way fuel valve with fuel tank.

## 16.CHECK ONE-WAY FUEL VALVE-II

1. Check that fuel is drained from the tank.
2. Remove fuel filler tube and hose.
3. Check one-way fuel valve for operation as per the following.  
When a stick is inserted, the valve should open, when removing stick it should close.

**Do not drop any material into the tank.**

Is the inspection result normal?

- YES >> INSPECTION END
- NO >> Replace fuel filler tube or replace one-way fuel valve with fuel tank.

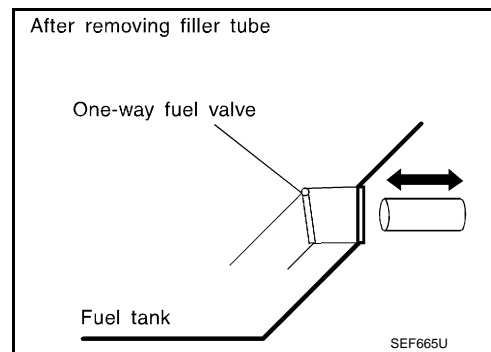

## Component Inspection (EVAP Vapor Cut Valve)

### 1.CHECK REFUELING EVAP VAPOR CUT VALVE

1. Turn ignition switch OFF.
  2. Remove fuel tank. Refer to [FL-10, "Removal and Installation"](#).
  3. Drain fuel from the tank as per the following:
    - Remove fuel gauge retainer.
    - Drain fuel from the tank using a handy pump into a fuel container.
  4. Check refueling EVAP vapor cut valve for being stuck to close as per the following.  
Blow air into the refueling EVAP vapor cut valve (from the end of EVAP/ORVR line hose), and check that the air flows freely into the tank.
  5. Check refueling EVAP vapor cut valve for being stuck to open as per the following.
    - Connect vacuum pump to hose end.
    - Remove fuel gauge retainer with fuel gauge unit.
- Always replace O-ring with new one.**
- Turn fuel tank upside down.

# ON BOARD REFUELING VAPOR RECOVERY (ORVR)

[VK56VD FOR MEXICO]

## < DTC/CIRCUIT DIAGNOSIS >

- Apply vacuum pressure to hose end [-13.3 kPa (-0.136 kg/cm<sup>3</sup>, -1.93 psi)] with fuel gauge retainer remaining open and check that the pressure is applicable.

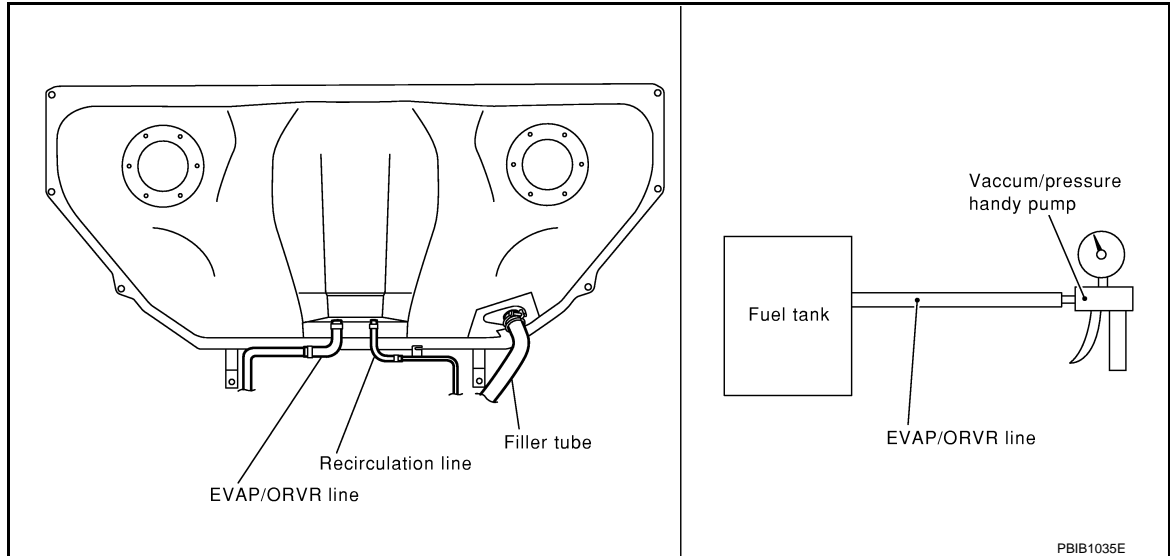

Is the inspection result normal?

YES >> INSPECTION END

NO >> Replace refueling EVAP vapor cut valve with fuel tank.



# REFRIGERANT PRESSURE SENSOR

< DTC/CIRCUIT DIAGNOSIS >

[VK56VD FOR MEXICO]

## REFRIGERANT PRESSURE SENSOR

### Component Function Check

INFOID:000000007758570

#### 1. CHECK REFRIGERANT PRESSURE SENSOR FUNCTION

1. Start engine and warm it up to normal operating temperature.
2. Turn A/C switch and blower fan switch ON.
3. Check the voltage between ECM harness connector terminals as per the following.

| Connector | ECM   |          | Voltage (V) |
|-----------|---|----------|-------------|
|           | +   | -        |             |
|           | Terminal                                    | Terminal |             |
| M160      | 144<br>(Refrigerant pressure sensor signal) | 150      | 1.0 - 4.0   |

Is the inspection result normal?

- YES >> INSPECTION END  
NO >> Go to [EC-2001, "Diagnosis Procedure"](#).

### Diagnosis Procedure

INFOID:000000007758571

#### 1. CHECK REFRIGERANT PRESSURE SENSOR POWER SUPPLY CIRCUIT

1. Disconnect refrigerant pressure sensor harness connector.
2. Turn ignition switch ON.
3. Check the voltage between refrigerant pressure sensor harness connector and ground.

| Refrigerant pressure sensor |          | Ground | Voltage (V) |
|-----------------------------|----------|--------|-------------|
| Connector                   | Terminal |        |             |
| E77                         | 3        | Ground | Approx. 5 V |

Is the inspection result normal?

- YES >> GO TO 3.  
NO >> GO TO 2.

#### 2. DETECT MALFUNCTIONING PART

Check the following.

- Harness for open or short between ECM and refrigerant pressure sensor
- Loose or poor connection for each connector and harness

>> Repair open circuit, short to ground or short to power in harness or connectors.

#### 3. CHECK REFRIGERANT PRESSURE SENSOR GROUND CIRCUIT FOR OPEN AND SHORT

1. Turn ignition switch OFF.
2. Disconnect ECM harness connector.
3. Check the continuity between refrigerant pressure sensor harness connector and ECM harness connector.

| Refrigerant pressure sensor |          | ECM       |          | Continuity |
|-----------------------------|----------|-----------|----------|------------|
| Connector                   | Terminal | Connector | Terminal |            |
| E77                         | 1        | M160      | 150      | Existed    |

4. Also check harness for short to ground and short to power.

Is the inspection result normal?

- YES >> GO TO 5.  
NO >> GO TO 4.

# REFRIGERANT PRESSURE SENSOR

< DTC/CIRCUIT DIAGNOSIS >

[VK56VD FOR MEXICO]

## 4. DETECT MALFUNCTIONING PART

Check the following.

- Harness for open or short between ECM and refrigerant pressure sensor
- Loose or poor connection for each connector and harness

>> Repair open circuit, short to ground or short to power in harness or connectors.

## 5. CHECK REFRIGERANT PRESSURE SENSOR INPUT SIGNAL CIRCUIT FOR OPEN AND SHORT

1. Check the continuity between refrigerant pressure sensor harness connector and ECM harness connector.

| Refrigerant pressure sensor |          | ECM       |          | Continuity |
|-----------------------------|----------|-----------|----------|------------|
| Connector                   | Terminal | Connector | Terminal |            |
| E77                         | 2        | M160      | 144      | Existed    |

2. Also check harness for short to ground and short to power.

Is the inspection result normal?

YES >> GO TO 7.

NO >> GO TO 6.

## 6. DETECT MALFUNCTIONING PART

Check the following.

- Harness for open or short between ECM and refrigerant pressure sensor
- Loose or poor connection for each connector and harness

>> Repair open circuit, short to ground or short to power in harness or connectors.

## 7. CHECK INTERMITTENT INCIDENT

Refer to [GI-44. "Intermittent Incident"](#).

Is the inspection result normal?

YES >> Replace refrigerant pressure sensor.

NO >> Repair or replace malfunctioning part.

# ENGINE CONTROL SYSTEM SYMPTOMS

< SYMPTOM DIAGNOSIS >

[VK56VD FOR MEXICO]

## SYMPTOM DIAGNOSIS

### ENGINE CONTROL SYSTEM SYMPTOMS

#### Symptom Table

INFOID:000000007758572

#### SYSTEM — BASIC ENGINE CONTROL SYSTEM

|   |                                       | SYMPTOM                          |              |                              |                        |                                 |                    |                    |                  |                        |                                  |                            |                           | Reference page |  |
|---|---------------------------------------|----------------------------------|--------------|------------------------------|------------------------|---------------------------------|--------------------|--------------------|------------------|------------------------|----------------------------------|----------------------------|---------------------------|----------------|--|
|   |                                       | HARD/NO START/RESTART (EXCP. HA) | ENGINE STALL | HESITATION/SURGING/FLAT SPOT | SPARK KNOCK/DETONATION | LACK OF POWER/POOR ACCELERATION | HIGH IDLE/LOW IDLE | ROUGH IDLE/HUNTING | IDLING VIBRATION | SLOW/NO RETURN TO IDLE | OVERHEATS/WATER TEMPERATURE HIGH | EXCESSIVE FUEL CONSUMPTION | EXCESSIVE OIL CONSUMPTION |                | BATTERY DEAD (UNDER CHARGE)  |
| Warranty symptom code                     |                                       | AA                               | AB           | AC                           | AD                     | AE                              | AF                 | AG                 | AH               | AJ                     | AK                               | AL                         | AM                        | HA             |  |
| Fuel                                      | Low pressure fuel pump circuit        | 1                                | 1            | 2                            | 3                      | 2                               |                    | 2                  | 2                |                        |                                  | 3                          |                           | 2              | <a href="#">EC-1989</a>  |
|   | Low fuel pressure sensor circuit      |                                  |              | 4                            |                        | 4                               |                    |                    |                  |                        |                                  |                            |                           |                | <a href="#">EC-1962</a>  |
|   | Fuel pressure regulator system        | 3                                | 3            | 4                            | 4                      | 4                               | 4                  | 4                  | 4                | 4                      |                                  | 4                          |                           |                | <a href="#">EC-1692</a>  |
|   | Fuel injector circuit                 | 1                                | 1            | 2                            | 3                      | 2                               |                    | 2                  | 2                |                        |                                  | 2                          |                           |                | <a href="#">EC-1976</a>  |
|   | Evaporative emission system           | 3                                | 3            | 4                            | 4                      | 4                               | 4                  | 4                  | 4                | 4                      |                                  | 4                          |                           |                | <a href="#">EC-2011</a>  |
|   | FRP sensor circuit                    | 1                                | 1            | 2                            | 2                      | 2                               |                    | 2                  | 2                |                        |                                  | 2                          |                           |                | <a href="#">EC-1807</a>  |
|   | High pressure fuel pump circuit       |                                  |              | 4                            |                        | 3                               |                    |                    |                  |                        |                                  |                            |                           |                | <a href="#">EC-1979</a>  |
| Air                                       | Positive crankcase ventilation system | 3                                | 3            | 4                            | 4                      | 4                               | 4                  | 4                  | 4                | 4                      |                                  | 4                          | 1                         |                | <a href="#">EC-2012</a>  |
|   | Incorrect idle speed adjustment       |                                  |              |                              |                        |                                 | 1                  | 1                  | 1                | 1                      |                                  | 1                          |                           |                | <a href="#">EC-1679</a>  |
|   | Electric throttle control actuator    | 1                                | 1            | 2                            | 3                      | 3                               | 2                  | 2                  | 2                | 2                      |                                  | 2                          |                           | 2              | <a href="#">EC-1893</a><br><a href="#">EC-1899</a>   |
| Ignition                                  | Incorrect ignition timing adjustment  | 3                                | 3            | 1                            | 1                      | 1                               |                    | 1                  | 1                |                        |                                  | 1                          |                           |                | <a href="#">EC-1984</a>  |
|   | Ignition circuit                      | 1                                | 1            | 2                            | 2                      | 2                               |                    | 2                  | 2                |                        |                                  | 2                          |                           |                | <a href="#">EC-1984</a>  |
| Main power supply and ground circuit      |                                       | 2                                | 2            | 3                            | 3                      | 3                               |                    | 3                  | 3                |                        | 2                                | 3                          |                           |                | <a href="#">EC-1707</a>  |
| Mass air flow sensor circuit              |                                       | 1                                |              |                              | 2                      |                                 |                    |                    |                  |                        |                                  |                            |                           |                | <a href="#">EC-1749</a>  |
| Engine coolant temperature sensor circuit |                                       |                                  |              |                              | 3                      |                                 |                    |                    |                  |                        |                                  |                            |                           |                |  |
| Air fuel ratio (A/F) sensor 1 circuit     |                                       | 1                                | 2            | 3                            | 2                      |                                 |                    | 2                  | 2                |                        |                                  | 2                          |                           |                | <a href="#">EC-1764</a><br><a href="#">EC-1768</a><br><a href="#">EC-1771</a><br><a href="#">EC-1774</a> |
| Throttle position sensor circuit          |                                       |                                  |              |                              |                        |                                 |                    |                    |                  |                        |                                  |                            |                           |                |  |
| Accelerator pedal position sensor circuit |                                       |                                  |              | 3                            | 2                      | 1                               |                    |                    |                  |                        |                                  |                            |                           |                | <a href="#">EC-1950</a><br><a href="#">EC-1953</a><br><a href="#">EC-1957</a>                            |

# ENGINE CONTROL SYSTEM SYMPTOMS

< SYMPTOM DIAGNOSIS >

[VK56VD FOR MEXICO]

|  | SYMPTOM                          |              |                              |                        |                                 |                    |                    |                  |                        |                                  |                            |                           |                             | Reference page  |
|--|----------------------------------|--------------|------------------------------|------------------------|---------------------------------|--------------------|--------------------|------------------|------------------------|----------------------------------|----------------------------|---------------------------|-----------------------------|---|
|  | HARD/NO START/RESTART (EXCP. HA) | ENGINE STALL | HESITATION/SURGING/FLAT SPOT | SPARK KNOCK/DETONATION | LACK OF POWER/POOR ACCELERATION | HIGH IDLE/LOW IDLE | ROUGH IDLE/HUNTING | IDLING VIBRATION | SLOW/NO RETURN TO IDLE | OVERHEATS/WATER TEMPERATURE HIGH | EXCESSIVE FUEL CONSUMPTION | EXCESSIVE OIL CONSUMPTION | BATTERY DEAD (UNDER CHARGE) |   |
| Warranty symptom code                                | AA                               | AB           | AC                           | AD                     | AE                              | AF                 | AG                 | AH               | AJ                     | AK                               | AL                         | AM                        | HA                          |   |
| Knock sensor circuit                                 |                                  |              | 2                            |                        |                                 |                    |                    |                  |                        |                                  | 3                          |                           |                             | <a href="#">EC-1822</a>   |
| Engine oil temperature sensor                        |                                  |              | 4                            |                        | 2                               |                    |                    |                  |                        |                                  | 3                          |                           |                             | <a href="#">EC-1810</a>   |
| Engine oil pressure sensor                           |                                  |              | 4                            |                        | 4                               | 3                  | 3                  | 3                |                        |                                  | 3                          |                           |                             | <a href="#">EC-1847</a>   |
| Crankshaft position sensor circuit                   | 2                                | 2            |                              |                        |                                 |                    |                    |                  |                        |                                  |                            |                           |                             | <a href="#">EC-1824</a>   |
| Camshaft position sensor circuit                     | 3                                | 2            |                              |                        |                                 |                    |                    |                  |                        |                                  |                            |                           |                             | <a href="#">EC-1828</a>   |
| Vehicle speed signal circuit                         |                                  | 2            | 3                            |                        | 3                               |                    |                    |                  |                        |                                  | 3                          |                           |                             | <a href="#">EC-1841</a>   |
| Power steering pressure sensor circuit               |                                  | 2            |                              |                        |                                 |                    | 3                  | 3                |                        |                                  |                            |                           |                             | <a href="#">EC-1853</a>   |
| ECM  | 2                                | 2            | 3                            | 3                      | 3                               | 3                  | 3                  | 3                | 3                      | 3                                | 3                          |                           |                             | <a href="#">EC-1858</a><br><a href="#">EC-1860</a>  |
| Intake valve timing control solenoid valve circuit   |                                  | 3            | 2                            |                        | 1                               | 3                  | 2                  | 2                | 3                      |                                  | 3                          |                           |                             | <a href="#">EC-1717</a><br><a href="#">EC-1731</a>  |
| Exhaust valve timing control solenoid valve circuit  |                                  | 3            | 2                            |                        | 1                               | 3                  | 2                  | 2                | 3                      |                                  | 3                          |                           |                             | <a href="#">EC-1721</a><br><a href="#">EC-1734</a>  |
| Exhaust valve timing control position sensor circuit | 5                                | 5            | 5                            | 5                      | 5                               |                    | 5                  | 5                |                        |                                  | 5                          |                           |                             | <a href="#">EC-1872</a>   |
| VVEL control module                                  | 3                                |              | 4                            | 4                      | 3                               |                    |                    |                  |                        |                                  |                            |                           |                             | <a href="#">EC-1940</a><br><a href="#">EC-1941</a>  |
| VVEL actuator motor                                  | 3                                |              | 4                            | 4                      | 3                               |                    |                    |                  |                        |                                  |                            |                           |                             | <a href="#">EC-1879</a>   |
| VVEL actuator motor relay                            | 3                                |              | 4                            | 4                      | 3                               |                    |                    |                  |                        |                                  |                            |                           |                             | <a href="#">EC-1882</a>   |
| VVEL control shaft position sensor                   | 3                                |              | 4                            | 4                      | 3                               |                    |                    |                  |                        |                                  |                            |                           |                             | <a href="#">EC-1876</a>   |
| PNP signal circuit                                   |                                  |              | 3                            |                        | 3                               |                    | 3                  | 3                |                        |                                  | 3                          |                           |                             | <a href="#">EC-1865</a>   |
| Refrigerant pressure sensor circuit                  |                                  | 2            |                              |                        |                                 | 3                  |                    |                  | 3                      |                                  | 4                          |                           |                             | <a href="#">EC-2001</a>   |
| Electrical load signal circuit                       |                                  |              |                              |                        |                                 |                    | 3                  |                  |                        |                                  |                            |                           |                             | <a href="#">EC-1971</a>   |
| Air conditioner circuit                              | 2                                | 2            | 3                            | 3                      | 3                               | 3                  | 3                  | 3                | 3                      |                                  | 3                          |                           | 2                           | <a href="#">HAC-68</a>  |
| ABS actuator and electric unit (control unit)        |                                  |              | 4                            |                        |                                 |                    |                    |                  |                        |                                  |                            |                           |                             | <a href="#">BRC-55</a>  |
| Cooling fan control module                           | 5                                | 5            | 5                            | 5                      | 5                               |                    | 5                  | 5                | 5                      | 4                                | 5                          |                           |                             | <a href="#">EC-1966</a>   |
| Manifold absolute pressure sensor circuit            |                                  |              |                              |                        |                                 |                    |                    |                  |                        |                                  | 3                          |                           |                             | <a href="#">EC-1993</a>   |
| Battery current sensor                               |                                  |              |                              |                        |                                 | 4                  | 5                  | 5                |                        |                                  |                            |                           | 3                           | <a href="#">EC-1904</a><br><a href="#">EC-1908</a><br><a href="#">EC-1912</a><br><a href="#">EC-1916</a><br><a href="#">EC-1920</a> |
| Heated oxygen sensor 2                               |                                  |              | 6                            |                        | 6                               |                    | 6                  | 6                |                        |                                  | 5                          |                           |                             | <a href="#">EC-1779</a><br><a href="#">EC-1785</a><br><a href="#">EC-1793</a>   |

# ENGINE CONTROL SYSTEM SYMPTOMS

< SYMPTOM DIAGNOSIS >

[VK56VD FOR MEXICO]

1 - 6: The numbers refer to the order of inspection.

(continued on next page)

## SYSTEM — ENGINE MECHANICAL & OTHER

|                       |   | SYMPTOM                          |              |                              |                        |                                 |                    |                    |                  |                        |                                  |                            |                           |                             | Reference page          |   |
|-----------------------|---|----------------------------------|--------------|------------------------------|------------------------|---------------------------------|--------------------|--------------------|------------------|------------------------|----------------------------------|----------------------------|---------------------------|-----------------------------|-------------------------|---|
|                       |   | HARD/NO START/RESTART (EXCP. HA) | ENGINE STALL | HESITATION/SURGING/FLAT SPOT | SPARK KNOCK/DETONATION | LACK OF POWER/POOR ACCELERATION | HIGH IDLE/LOW IDLE | ROUGH IDLE/HUNTING | IDLING VIBRATION | SLOW/NO RETURN TO IDLE | OVERHEATS/WATER TEMPERATURE HIGH | EXCESSIVE FUEL CONSUMPTION | EXCESSIVE OIL CONSUMPTION | BATTERY DEAD (UNDER CHARGE) |                         |   |
| Warranty symptom code |   | AA                               | AB           | AC                           | AD                     | AE                              | AF                 | AG                 | AH               | AJ                     | AK                               | AL                         | AM                        | HA                          |                         |   |
| Fuel                  | Fuel tank   | 5                                |              |                              |                        |                                 |                    |                    |                  |                        |                                  |                            |                           |                             | <a href="#">FL-4</a>    |   |
|                       | Fuel piping   |                                  |              | 5                            | 5                      | 5                               |                    | 5                  | 5                |                        | 5                                |                            |                           |                             |                         |   |
|                       | Vapor lock  |                                  |              | 5                            |                        |                                 |                    |                    |                  |                        |                                  |                            |                           |                             |                         | — |
|                       | Valve deposit   |                                  |              |                              |                        |                                 |                    |                    |                  |                        |                                  |                            |                           |                             |                         | — |
|                       | Poor fuel (Heavy weight gasoline, Low octane)   | 5                                |              |                              | 5                      | 5                               | 5                  |                    | 5                | 5                      |                                  |                            | 5                         |                             |                         | — |
| Air                   | Air duct  |                                  |              |                              |                        |                                 |                    |                    |                  |                        |                                  |                            |                           |                             | <a href="#">EM-185</a>  |   |
|                       | Air cleaner   |                                  |              |                              |                        |                                 |                    |                    |                  |                        |                                  |                            |                           |                             | <a href="#">EM-184</a>  |   |
|                       | Air leakage from air duct (Mass air flow sensor — electric throttle control actuator) |                                  | 5            | 5                            |                        | 5                               |                    | 5                  | 5                |                        |                                  | 5                          |                           |                             | <a href="#">EM-185</a>  |   |
|                       | Electric throttle control actuator  | 5                                |              |                              | 5                      |                                 | 5                  |                    |                  | 5                      |                                  |                            |                           |                             | <a href="#">EC-1899</a> |   |
|                       | Air leakage from intake manifold/Collector/Gasket                                     |                                  |              |                              |                        |                                 |                    |                    |                  |                        |                                  |                            |                           |                             | <a href="#">EM-191</a>  |   |
| Cranking              | Battery   | 1                                | 1            | 1                            |                        | 1                               |                    | 1                  | 1                |                        |                                  |                            |                           | 1                           | <a href="#">PG-135</a>  |   |
|                       | Generator circuit   |                                  |              |                              |                        |                                 |                    |                    |                  |                        |                                  |                            |                           |                             | <a href="#">CHG-11</a>  |   |
|                       | Starter circuit   | 3                                |              |                              |                        |                                 |                    |                    |                  |                        |                                  | 1                          |                           |                             | <a href="#">STR-9</a>   |   |
|                       | Signal plate  | 6                                |              |                              |                        |                                 |                    |                    |                  |                        |                                  |                            |                           |                             | <a href="#">EM-284</a>  |   |
|                       | PNP signal  | 4                                |              |                              |                        |                                 |                    |                    |                  |                        |                                  |                            |                           |                             | <a href="#">TM-102</a>  |   |
| Engine                | Cylinder head   | 5                                | 5            | 5                            | 5                      | 5                               |                    | 5                  | 5                |                        |                                  | 5                          |                           |                             | <a href="#">EM-270</a>  |   |
|                       | Cylinder head gasket  |                                  |              |                              |                        |                                 |                    |                    |                  |                        | 4                                |                            | 3                         |                             |                         |   |
|                       | Cylinder block  |                                  |              |                              |                        |                                 |                    |                    |                  |                        |                                  |                            |                           |                             |                         |   |
|                       | Piston  |                                  |              |                              |                        |                                 |                    |                    |                  |                        |                                  |                            | 4                         |                             |                         |   |
|                       | Piston ring   |                                  |              |                              |                        |                                 |                    |                    |                  |                        |                                  |                            |                           |                             |                         |   |
|                       | Connecting rod  | 6                                | 6            | 6                            | 6                      | 6                               |                    | 6                  | 6                |                        |                                  | 6                          |                           |                             | <a href="#">EM-284</a>  |   |
|                       | Bearing   |                                  |              |                              |                        |                                 |                    |                    |                  |                        |                                  |                            |                           |                             |                         |   |
| Crankshaft            |   |                                  |              |                              |                        |                                 |                    |                    |                  |                        |                                  |                            |                           |                             |                         |   |

A  
C  
D  
E  
F  
G  
H  
I  
J  
K  
L  
M  
N  
O  
P

EC

# ENGINE CONTROL SYSTEM SYMPTOMS

< SYMPTOM DIAGNOSIS >

[VK56VD FOR MEXICO]

|   |   | SYMPTOM                          |              |                              |                        |                                 |                    |                    |                  |                        |                                  |                            |                           | Reference<br>page                              |  |
|---|---|----------------------------------|--------------|------------------------------|------------------------|---------------------------------|--------------------|--------------------|------------------|------------------------|----------------------------------|----------------------------|---------------------------|--|--|
|   |   | HARD/NO START/RESTART (EXCP. HA) | ENGINE STALL | HESITATION/SURGING/FLAT SPOT | SPARK KNOCK/DETONATION | LACK OF POWER/POOR ACCELERATION | HIGH IDLE/LOW IDLE | ROUGH IDLE/HUNTING | IDLING VIBRATION | SLOW/NO RETURN TO IDLE | OVERHEATS/WATER TEMPERATURE HIGH | EXCESSIVE FUEL CONSUMPTION | EXCESSIVE OIL CONSUMPTION |  | BATTERY DEAD (UNDER CHARGE)  |
| Warranty symptom code                             |   | AA                               | AB           | AC                           | AD                     | AE                              | AF                 | AG                 | AH               | AJ                     | AK                               | AL                         | AM                        | HA   |  |
| Valve mechanism                                   | Timing chain  |                                  |              |                              |                        |                                 |                    |                    |                  |                        |                                  |                            |                           |  | <a href="#">EM-244</a>   |
|   | Camshaft  |                                  |              |                              |                        |                                 |                    |                    |                  |                        |                                  |                            |                           |  | <a href="#">EM-255</a>   |
|   | Intake valve timing control                                     | 5                                | 5            | 5                            | 5                      | 5                               |                    | 5                  | 5                |                        |                                  | 5                          |                           |  | <a href="#">EM-244</a>   |
|   | Exhaust valve timing control                                    |                                  |              |                              |                        |                                 |                    |                    |                  |                        |                                  |                            |                           |  |  |
|   | Intake valve  |                                  |              |                              |                        |                                 |                    |                    |                  |                        |                                  |                            | 3                         |  | <a href="#">EM-270</a>   |
|   | Exhaust valve   |                                  |              |                              |                        |                                 |                    |                    |                  |                        |                                  |                            |                           |  |  |
| Exhaust   | Exhaust manifold/Tube/Muffler/Gasket                            | 5                                | 5            | 5                            | 5                      | 5                               |                    | 5                  | 5                |                        |                                  | 5                          |                           |  | <a href="#">EM-225</a><br><a href="#">EX-8</a><br><a href="#">EX-8</a>   |
|   | Three way catalyst  |                                  |              |                              |                        |                                 |                    |                    |                  |                        |                                  |                            |                           |  |  |
| Lubrica-tion                                      | Oil pan/Oil strainer/Oil pump/Oil filter/Oil gallery/Oil cooler | 5                                | 5            | 5                            | 5                      | 5                               |                    | 5                  | 5                |                        |                                  | 5                          |                           |  | <a href="#">EM-230</a><br><a href="#">EM-206</a><br><a href="#">EM-209</a><br><a href="#">LU-21</a><br><a href="#">LU-26</a><br><a href="#">LU-29</a><br><a href="#">LU-28</a> |
|   | Oil level (Low)/Filthy oil                                      |                                  |              |                              |                        |                                 |                    |                    |                  |                        |                                  |                            |                           | <a href="#">LU-23</a>                          |  |
| Cooling   | Radiator/Hose/Radiator filler cap                               |                                  |              |                              |                        |                                 |                    |                    |                  |                        |                                  |                            |                           | <a href="#">CO-38</a><br><a href="#">CO-38</a> |  |
|   | Thermostat  |                                  |              |                              |                        |                                 |                    |                    |                  | 5                      |                                  |                            |                           | <a href="#">CO-49</a>                          |  |
|   | Water pump  | 5                                | 5            | 5                            | 5                      | 5                               |                    | 5                  | 5                |                        | 4                                | 5                          |                           | <a href="#">CO-47</a>                          |  |
|   | Water gallery   |                                  |              |                              |                        |                                 |                    |                    |                  |                        |                                  |                            |                           | <a href="#">CO-30</a>                          |  |
|   | Cooling fan   |                                  |              |                              |                        |                                 |                    |                    |                  |                        |                                  |                            |                           | <a href="#">CO-45</a>                          |  |
|   | Coolant level (Low)/Contaminated coolant                        |                                  |              |                              |                        |                                 |                    |                    |                  |                        | 5                                |                            |                           | <a href="#">CO-34</a>                          |  |
| IVIS (INFINITI Vehicle Immobilizer System — NATS) |   | 1                                | 1            |                              |                        |                                 |                    |                    |                  |                        |                                  |                            |                           | <a href="#">SEC-39</a>                         |  |

1 - 6: The numbers refer to the order of inspection.

# INFINITI DRIVE MODE SELECTOR

< SYMPTOM DIAGNOSIS >

[VK56VD FOR MEXICO]

## INFINITI DRIVE MODE SELECTOR

### Symptom Table

INFOID:000000007758573

#### SYSTEM - DRIVE MODE SELECTOR -

| Malfunction  | Check item  |   | Probable malfunctioning part/<br>Action   |
|--|---|---|---|
| ECO pedal reaction force is not generated when in ECO mode.  | Only ECO pedal reaction force is not generated.<br>[Intelligent pedal (distance control assist) operates normally.] | The central switch of the navigation system operates normally.  | Perform self-diagnosis of the engine control system.<br>Refer to <a href="#">EC-1651</a> , " <a href="#">DTC Index</a> ".   |
|  |   | The central switch of the navigation system malfunctions.   | Perform self-diagnosis of the navigation system.<br>Refer to <a href="#">AV-97</a> , " <a href="#">Symptom Table</a> " (BASE AUDIO WITHOUT NAVIGATION) or <a href="#">AV-252</a> , " <a href="#">Symptom Table</a> " (BOSE AUDIO WITH NAVIGATION)   |
| Intelligent pedal (distance control assist) reaction force is not generated as well.   |   |   | Perform self-diagnosis of the ADAS control unit, ICC sensor, and Accelerator pedal actuator. <ul style="list-style-type: none"> <li>• ADAS C/U: Refer to <a href="#">DAS-92</a>, "<a href="#">DTC Index</a>".</li> <li>• ICC SENSOR: Refer to <a href="#">CCS-57</a>, "<a href="#">DTC Index</a>".</li> <li>• ACCELERATOR PEDAL ACTUATOR: Refer to <a href="#">DAS-101</a>, "<a href="#">DTC Index</a>".</li> </ul> |
| When in ECO mode, settings of ECO pedal reaction force cannot be changed or vehicle behavior does not agree to the settings. | Intelligent pedal (distance control assist) reaction force has a malfunction as well.                               |   | Perform self-diagnosis of the ADAS control unit, ICC sensor, and Accelerator pedal actuator. <ul style="list-style-type: none"> <li>• ADAS C/U: Refer to <a href="#">DAS-92</a>, "<a href="#">DTC Index</a>".</li> <li>• ICC SENSOR: Refer to <a href="#">DAS-98</a>, "<a href="#">DTC Index</a>".</li> <li>• ACCELERATOR PEDAL ACTUATOR: Refer to <a href="#">DAS-101</a>, "<a href="#">DTC Index</a>".</li> </ul> |
|  | Intelligent pedal (distance control assist) reaction force is normal.   | The central switch of the navigation system operates normally.  | Perform self-diagnosis of the engine control system.<br>Refer to <a href="#">EC-1651</a> , " <a href="#">DTC Index</a> ".   |
| The central switch of the navigation system malfunctions.  |   | Perform self-diagnosis of the navigation system.<br>Refer to <a href="#">AV-97</a> , " <a href="#">Symptom Table</a> " (BASE AUDIO WITHOUT NAVIGATION) or <a href="#">AV-252</a> , " <a href="#">Symptom Table</a> " (BOSE AUDIO WITH NAVIGATION) |   |

A  
EC  
C  
D  
E  
F  
G  
H  
I  
J  
K  
L  
M  
N  
O  
P

## NORMAL OPERATING CONDITION

### Description

INFOID:000000007758574

#### FUEL CUT CONTROL (AT NO LOAD AND HIGH ENGINE SPEED)

If the engine speed is above 1,800 rpm under no load (for example, the selector lever position is neutral and engine speed is over 1,800 rpm) fuel will be cut off after some time. The exact time when the fuel is cut off varies based on engine speed.

Fuel cut will be operated until the engine speed reaches 1,500 rpm, then fuel cut will be cancelled.

**NOTE:**

This function is different from deceleration control listed under direct injection gasoline system, [EC-1586](#). "[DIRECT INJECTION GASOLINE SYSTEM : System Description](#)".



# PERIODIC MAINTENANCE

## IDLE SPEED

Inspection

INFOID:000000007758575

A

EC

### 1. CHECK IDLE SPEED

Ⓜ With CONSULT  
Check idle speed in "DATA MONITOR" mode with CONSULT.

C

Ⓢ With GST  
Check idle speed with Service \$01 of GST.

D

>> INSPECTION END

E

F

G

H

I

J

K

L

M

N

O

P

# IGNITION TIMING

< PERIODIC MAINTENANCE >

[VK56VD FOR MEXICO]

## IGNITION TIMING

### Inspection

INFOID:000000007758576

### 1. CHECK IGNITION TIMING

1. Attach timing light to loop wire as shown.

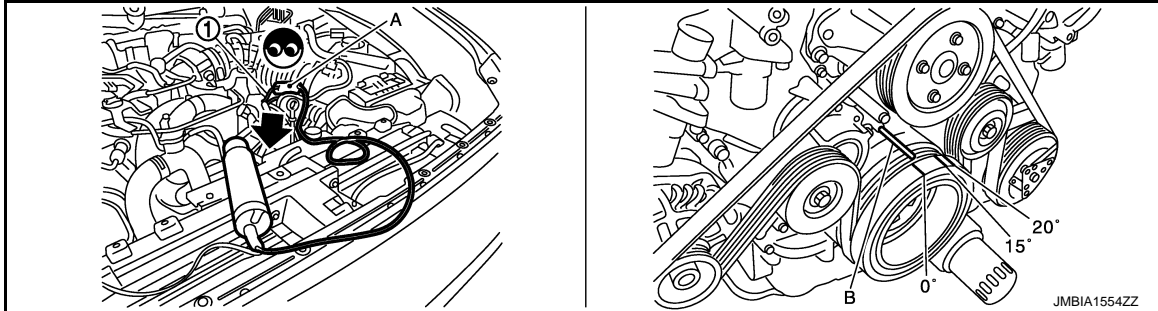

1. Loop wire
  - A. Timing light
  - B. Timing indicator
2. Check ignition timing.

>> INSPECTION END

# EVAP LEAK CHECK

< PERIODIC MAINTENANCE >

[VK56VD FOR MEXICO]

## EVAP LEAK CHECK

### Inspection

INFOID:000000007758577

#### CAUTION:

- Do not use compressed air or a high pressure pump.
- Do not exceed 4.12 kPa (0.042 kg/cm<sup>2</sup>, 0.6 psi) of pressure in EVAP system.

#### NOTE:

- Do not start engine.
- Improper installation of EVAP service port adapter (commercial service tool) to the EVAP service port may cause a leak.

#### ⊗ WITHOUT CONSULT

1. To locate the EVAP leak, install EVAP service port adapter (commercial service tool) and pressure pump to EVAP service port.
2. Apply battery voltage between the terminals of EVAP canister vent control valve to make a closed EVAP system.
3. To locate the leak, deliver positive pressure to the EVAP system until pressure gauge points reach 1.38 to 2.76 kPa (0.014 to 0.028 kg/cm<sup>2</sup>, 0.2 to 0.4 psi).
4. Remove EVAP service port adapter (commercial service tool) and hose with pressure pump.

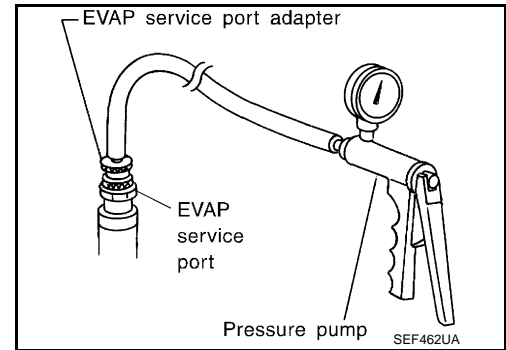

5. Locate the leak using a leak detector (commercial service tool). Refer to [EC-1596, "EVAPORATIVE EMISSION SYSTEM : System Diagram"](#).

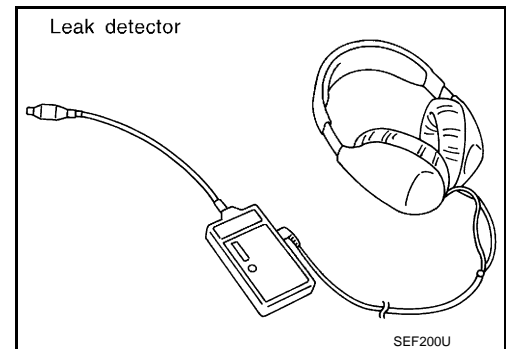

A  
EC  
C  
D  
E  
F  
G  
H  
I  
J  
K  
L  
M  
N  
O  
P

# POSITIVE CRANKCASE VENTILATION

< PERIODIC MAINTENANCE >

[VK56VD FOR MEXICO]

## POSITIVE CRANKCASE VENTILATION

### Inspection

INFOID:000000007758578

#### 1. CHECK PCV VALVE

With engine running at idle, remove PCV valve from rocker cover. A properly working valve makes a hissing noise as air passes through it. A strong vacuum should be felt immediately when a finger is placed over valve inlet.

Is the inspection result normal?

- YES >> INSPECTION END
- NO >> Replace PCV valve.

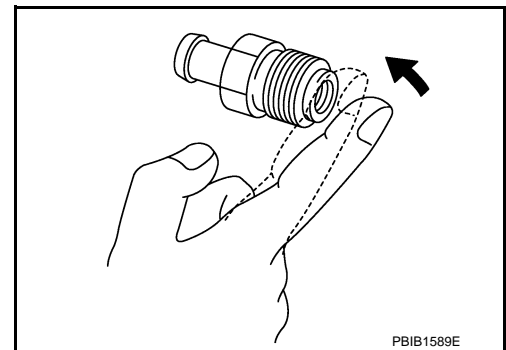

# REMOVAL AND INSTALLATION

## ECM

### Removal and Installation

INFOID:000000007758579

#### REMOVAL

1. Remove the instrument lower cover. Refer to [IP-13, "Removal and Installation"](#).
2. Remove the dash side finisher (LH). Refer to [INT-34, "DASH SIDE FINISHER : Removal and Installation"](#).
3. Remove the ECM cover bolts (A) and remove ECM cover (1).

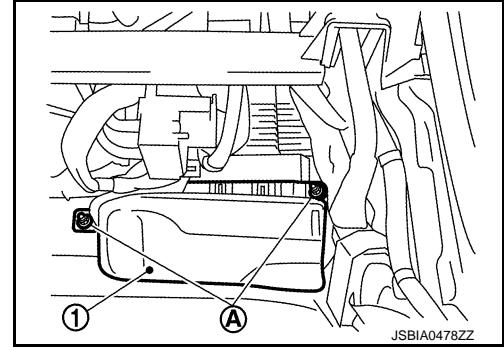

4. Disconnect ECM harness connectors.
5. Remove ECM bracket bolt (A)
6. Slide the ECM bracket (1) upward and then remove ECM bracket with ECM.
7. Remove ECM bracket bolts (B) and separate ECM (2) and ECM bracket.

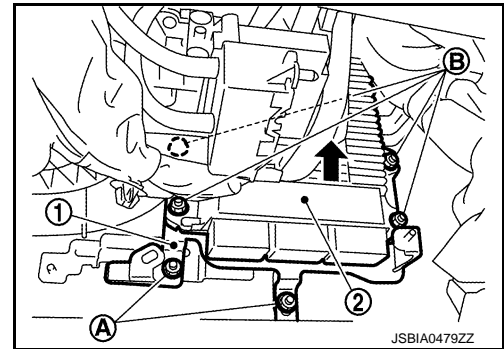

#### INSTALLATION

Install in the reverse order of removal.

**CAUTION:**

**Must be perform additional service when replacing ECM. Refer to [EC-1683, "Work Procedure"](#).**

# VVEL CONTROL MODULE

< REMOVAL AND INSTALLATION >

[VK56VD FOR MEXICO]

## VVEL CONTROL MODULE

### Removal and Installation

INFOID:000000007758580

#### REMOVAL

1. Remove hoodledge cover (RH) and cowl top cover (RH). Refer to [EXT-21, "Removal and Installation"](#).
2. Remove the battery and battery tray. Refer to [PG-142, "Removal and Installation"](#).
3. Remove VVEL control module bracket bolts (A).
4. Remove the ground harness fix bolt (B).
5. Remove VVEL control module bracket (1).

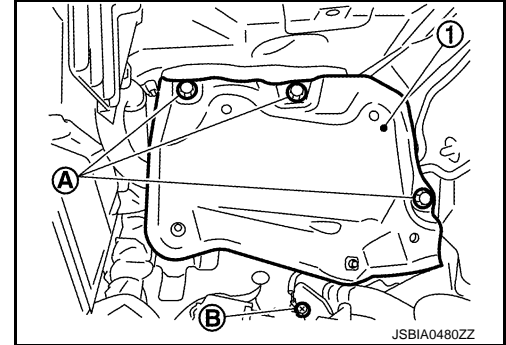

6. Disconnect VVEL control module harness connector.
7. Remove the fix bolts (A). And then separate VVEL control module (1), ground harness (2) and VVEL control module bracket (3).

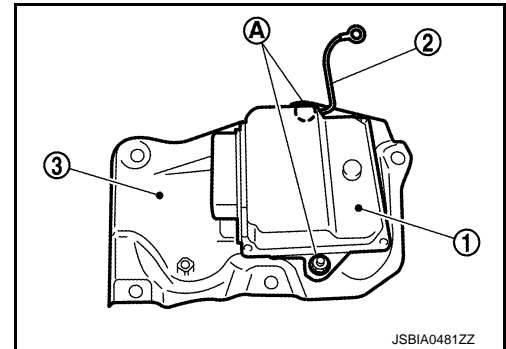

#### INSTALLATION

Install in the reverse order of removal.

#### **CAUTION:**

**Must be perform additional service when replacing VVEL control module. Refer to [EC-1684, "Work Procedure"](#).**

# FUEL PUMP CONTROL MODULE (FPCM)

< REMOVAL AND INSTALLATION >

[VK56VD FOR MEXICO]

## FUEL PUMP CONTROL MODULE (FPCM)

### Removal and Installation

INFOID:000000007758581

#### REMOVAL

1. Remove the rear wheel house finisher (RH). Refer to [INT-51, "TRUNK SIDE FINISHER : Removal and Installation"](#).
2. Disconnect fuel pump control module (FPCM) connector.
3. Remove mounting bolts and then remove fuel pump control module (FPCM).

#### INSTALLATION

Install in the reverse order of removal.

A

EC

C

D

E

F

G

H

I

J

K

L

M

N

O

P

# SERVICE DATA AND SPECIFICATIONS (SDS)

< SERVICE DATA AND SPECIFICATIONS (SDS)

[VK56VD FOR MEXICO]

## SERVICE DATA AND SPECIFICATIONS (SDS)

### SERVICE DATA AND SPECIFICATIONS (SDS)

#### Idle Speed

INFOID:0000000007758587

| Condition                     | Specification |
|-------------------------------|---------------|
| No load* (in P or N position) | 600 ± 50 rpm  |

\*: Under the following conditions

- A/C switch: OFF
- Electric load: OFF (Lights, heater fan & rear window defogger)
- Steering wheel: Kept in straight-ahead position

#### Ignition Timing

INFOID:0000000007758588

| Condition                     | Specification |
|-------------------------------|---------------|
| No load* (in P or N position) | 11 ± 2°BTDC   |

\*: Under the following conditions

- A/C switch: OFF
- Electric load: OFF (Lights, heater fan & rear window defogger)
- Steering wheel: Kept in straight-ahead position

#### Calculated Load Value

INFOID:0000000007758589

| Condition    | Specification (Using CONSULT or GST) |
|--------------|--------------------------------------|
| At idle      | 5 – 35%                              |
| At 2,500 rpm | 5 – 35%                              |

#### Mass Air Flow Sensor

INFOID:0000000007758590

|                                      |  |
|--------------------------------------|--|
| Supply voltage                       | Battery voltage (11 – 14 V)                            |
| Output voltage at idle               | 0.95 – 1.35 V*   |
| Mass air flow (Using CONSULT or GST) | 1.0 – 5.0 g/s at idle*<br>7.0 – 20.0 g/s at 2,500 rpm* |

\*: Engine is warmed up to normal operating temperature and running under no load.